



## **Engineering Specification**

**Type 15.0 XGA Color TFT/LCD Module**

**Model Name: N150X4-L01**

**Document Control Number: OEM N150X4-L01-02**

**Note: Specification is subject to change without notice. Consequently it is better to contact to International Display Technology before proceeding with the design of your product incorporating this module.**

**Sales Support  
International Display Technology**



## i Contents

i	Contents
ii	Record of Revision
<b>1.0</b>	<b>Handling Precautions</b>
<b>2.0</b>	<b>General Description</b>
2.1	Characteristics
2.2	Functional Block Diagram
<b>3.0</b>	<b>Absolute Maximum Ratings</b>
<b>4.0</b>	<b>Optical Characteristics</b>
<b>5.0</b>	<b>Signal Interface</b>
5.1	Connectors
5.2	Interface Signal Connector
5.3	Interface Signal Description
5.3.1	E-EDUD
5.4	Interface Signal Electrical Characteristics
5.4.1	Signal Electrical Characteristics for LVDS Receiver
5.4.2	LVDS Receiver Internal Circuit
5.4.3	Recommended Guidelines for Motherboard PCB Design and Cable Selection
5.5	Signal for Lamp connector
<b>6.0</b>	<b>Pixel format image</b>
<b>7.0</b>	<b>Parameter guide line for CFL Inverter</b>
<b>8.0</b>	<b>Interface Timings</b>
8.1	Timing Characteristics
8.2	Timing Definition
<b>9.0</b>	<b>Power Consumption</b>
<b>10.0</b>	<b>Power ON/OFF Sequence</b>
<b>11.0</b>	<b>Mechanical Characteristics</b>
<b>12.0</b>	<b>National Test Lab Requirement</b>



## ii Record of Revision

Date	Document Revision	Page	Summary
February 06,2003	OEM N150X4-L01-01	All	First Edition for customer. Based on Internal Spec."N150X4-IPI-01"
April 25,2003	OEM N150X4-L01-02	27-29	To Update Reference Drawings



## 1.0 Handling Precautions

- If any signals or power lines deviate from the power on/off sequence, it may cause shorten the life of the LCD module.
- The LCD panel and the CFL are made of glass and may break or crack if dropped on a hard surface, so please handle them with care.
- CMOS ICs are included in the LCD panel. They should be handled with care, to prevent electrostatic discharge.
- Do not press the reflector sheet at the LCD module to any directions.
- Do not stick the adhesive tape on the reflector sheet at the back of the LCD module.
- Please handle with care when mount in the system cover. Mechanical damage for lamp cable/lamp connector may cause safety problems.
- Small amount of materials having no flammability grade is used in the LCD module. The LCD module should be supplied by power complied with requirements of Limited Power Source (2.5, IEC60950 or UL60950), or be applied exemption conditions of flammability requirements (4.7.3.4, IEC60950 or UL60950) in an end product.
- The LCD module is designed so that the CFL in it is supplied by Limited Current Circuit (2.4, IEC60950 or UL60950).
- The fluorescent lamp in the liquid crystal display(LCD) contains mercury. Do not put it in trash that is disposed of in landfills. Dispose of it as required by local ordinances or regulations.
- Never apply detergent or other liquid directly to the screen.
- Wipe off water drop immediately. Long contact with water may cause discoloration or spots.
- When the panel surface is soiled, wipe it with absorbent cotton or other soft cloth; do not use solvents or abrasives.
- Do not touch the front screen surface in your system, even bezel.
- Gently wipe the covers and the screen with a soft cloth.

▪ The information contained herein is presented only as a guide for the applications of our products. No responsibility is assumed by International Display Technology for any infringements of patents or other right of the third partied which may result from its use. No license is granted by implication or otherwise under any patent or patent rights of International Display Technology or others.

▪ The information contained herein may be changed without prior notice. It is therefore advisable to contact International Display Technology before proceeding with the design of equipment incorporating this product.



## 2.0 General Description

This specification applies to the Type 15.0 Color TFT/LCD Module 'N150X4-L01'.  
This module is designed for a display unit of a notebook style personal computer.  
The screen format and electrical interface are intended to support the XGA (1024(H) x 768(V)) screen.  
Support color is native 262k colors ( RGB 6-bit data driver ).  
All input signals are LVDS(Low Voltage Differential Signaling) interface compatible.  
This module does not contain an inverter card for backlight.



## 2.1 Characteristics

The following items are characteristics summary on the table under 25 degree C condition:

CHARACTERISTICS ITEMS	SPECIFICATIONS
Screen Diagonal [cm]	38
Active Area [mm]	304.128(H) x 228.096(V)
Pixels H x V [pixels]	1024(x3) x 768
Pixel Pitch [mm]	0.297(per one triad) x 0.297
Pixel Arrangement	R.G.B. Vertical Stripe
Display Mode	Normally Black
White Luminance [cd/m <sup>2</sup> ]	215 Typ. (Screen Center, ICFL = 6.5mA)
Contrast Ratio	400 : 1 Typ. 300:1 Min
Viewing Angle	CR>=10:1 H: +/-85 deg., V: +/-85 deg. Typ. CR>=100:1 H: +/-40 deg., V: +/-40 deg. Typ.
Color Chromaticity	x:0.313 , y:0.329
Surface Treatment	Anti-Glare,AG160
Optical Rise + Fall Time	60msec Typ.; 120ms Max. (@25degC)
Nominal Input Voltage [VDD]	+3.3 V
Logic Power Consumption [watt]	1.6 Typ. (All White Pattern), 2.2 Max (worst pattern)
CFL Power Consumption [watt]	4.1Typ.(@ICFL=6.5mA)
Weight [grams]	585 Max.
Physical Size [mm]	317.3(W) x 242.0(H) x 6.2(D) Typ.
Electrical Interface	4 pairs Single LVDS(Single)
Support Color	Native 262K colors ( RGB 6-bit data driver )
Temperature Range [deg. C]	0 to +50 (Operating) -20 to +60 (Storage, Shipping)
CFL cable length	100 mm

## 2.2 Functional Block Diagram

The following diagram shows the functional block of the Type 15.0 Color TFT/LCD Module.

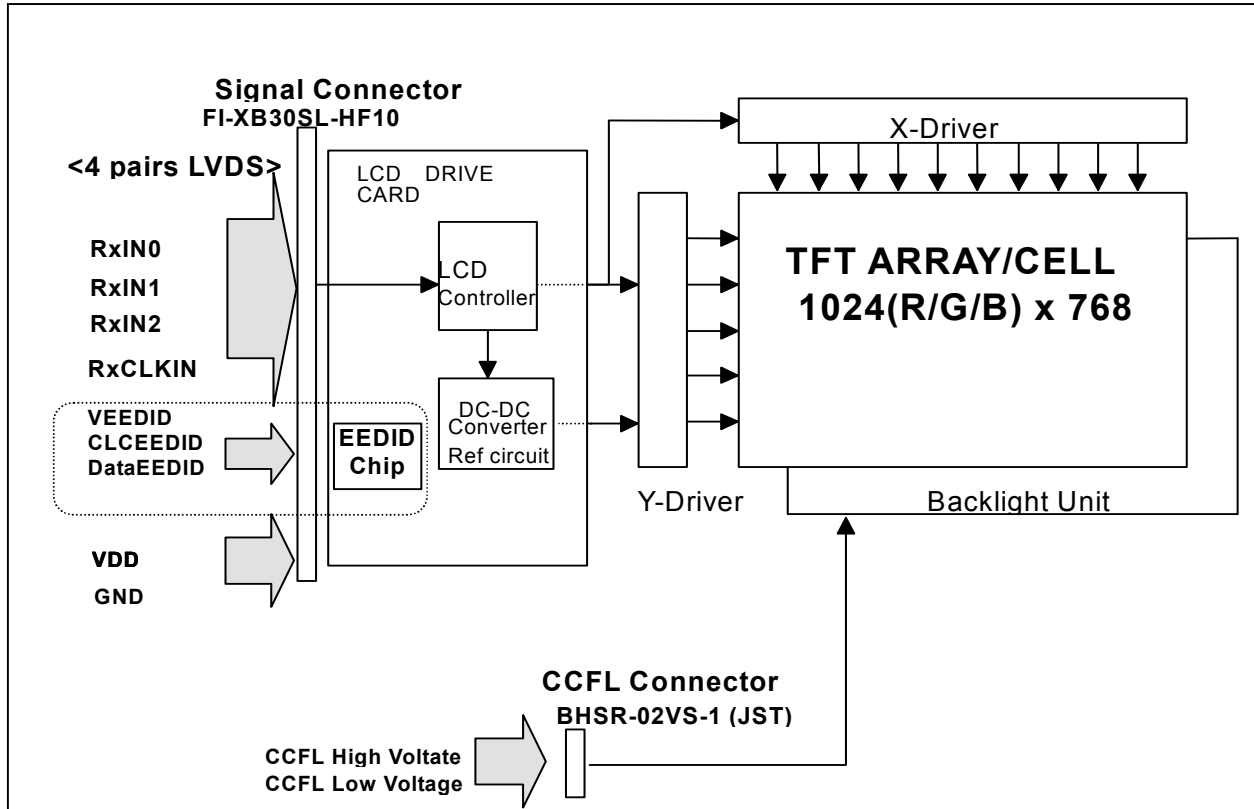



### 3.0 Absolute Maximum Ratings

Absolute maximum ratings of the module is as follows :

Item	Symbol	Min	Max	Unit	Conditions
Supply Voltage	VDD	-0.3	+4.0	V	
Input Voltage of Signal	Other Inputs	-0.3	VDD+0.3	V	
Lamp Ignition Voltage	Vinv	-	2,000	Vrms	
CFL Current	ICFL	-	7	mA rms	
CFL Peak Inrush Current	ICFLP	-	20mA / 50ms		A single pulse
Operating Temperature	TOP	0	+50	deg.C	<b>(Note 1)</b>
Operating Relative Humidity	HOP	8	95	%RH	<b>(Note 1)</b>
Storage Temperature	TST	-20	+60	deg.C	<b>(Note 1)</b>
Storage Relative Humidity	HST	5	95	%RH	<b>(Note 1)</b>
Vibration			1.5	G Hz	
Shock			50 18	G ms	Rectangle wave

**Note :**

1. Maximum Wet-Bulb should be 39 degree C and No condensation.





## 4.0 Optical Characteristics

The optical characteristics are measured under stable conditions as follows under 25 degree C condition:

Item	Conditions	Specification	
		Typ.	Note
Viewing Angle (Degrees)	Horizontal (Right)	85	-
	K $\geq$ 10 (Left)	85	-
	Vertical (Upper)	85	-
K:Contrast Ratio	K $\geq$ 10 (Lower)	85	-
Contrast ratio		400	-
Response Time (ms)	Rising + Falling	60	120 Max.
Color Chromaticity (CIE)	Red x	-	-
	Red y	-	-
	Green x	-	-
	Green y	-	-
	Blue x	-	-
	Blue y	-	-
	White x	0.313	-
	White y	0.329	-
White Luminance (cd/m <sup>2</sup> ) ICFL 6.0 mA		200Typ. Center	160Min Center



## 5.0 Signal Interface

### 5.1 Connectors

Physical interface is described as for the connector on module.

These connectors are capable of accommodating the following signals and will be following components.

Connector Name / Designation	For Signal Connector
Manufacturer	JAE
Type / Part Number	FI-XB30SL-HF10
Mating Receptacle/Part Number	FI-X30M, FI-X30C2L

Connector Name / Designation	For Lamp Connector
Manufacturer	JST
Type / Part Number	BHSR-02VS-1
Mating Type / Part Number	SM02B-BHSS-1



## 5.2 Interface Signal Connector

Pin #	Signal Name
1	GND
2	VDD
3	VDD
4	VEDID (Note 2, 3)
5	Reserved (Note 1)
6	CLKEEDID (Note 2, 4)
7	DataEEDID (Note 2, 4)
8	RxIN0-
9	RxIN0+
10	GND
11	RxIN1-
12	RxIN1+
13	GND
14	RxIN2-
15	RxIN2+

Pin #	Signal Name
16	GND
17	RxCLKIN-
18	RxCLKIN+
19	GND
20	NC
21	NC
22	GND
23	NC
24	NC
25	GND
26	NC
27	NC
28	GND
29	NC
30	NC

### Note :

- 'Reserved' pins are not allowed to connect any other line.
- This LCD Module complies with "VESA ENHANCED EXTENDED DISPLAY IDENTIFICATION DATA STANDARD Release A, Revision 1" and supports "EEDID version 1.3".
- $V_{EEDID}$  power source shall be the limited current circuit which has not exceeding 1A. (Reference Document : "Enhanced Display Data Channel (E-DDC™) Proposed Standard", VESA)
- Both  $CLK_{EEDID}$  line and  $DATA_{EEDID}$  line are pulled up with 10k ohm resistor to  $V_{EEDID}$  power source line at LCD panel, respectively.

Voltage levels of all input signals are LVDS compatible (except VDD, EEDID). Refer to "Signal Electrical Characteristics for LVDS Receiver", for voltage levels of all input signals.

## 5.3 Interface Signal Description

### Signal Description

Signal Name	Description
RxIN0+, RxIN0-	LVDS differential data input (RED0-RED5, GREEN0)
RxIN1+, RxIN1-	LVDS differential data input (GREEN1-GREEN5,BLUE0-BLUE1)
RxIN2+, RxIN2-	LVDS differential data input (BLUE2-BLUE5, HSync, VSync, DSPTMG)
RxCLKIN+, RxCLKIN-	LVDS differential clock input(DTCLK)
VDD	+3.3V Power Supply
GND	Ground

### Note :

- Input signals shall be low or Hi-Z state when VDD is off.



SIGNAL NAME	Description
+RED5 +RED4 +RED3 +RED2 +RED1 +RED0	Red Data 5 (MSB) Red Data 4 Red Data 3 Red Data 2 Red Data 1 Red Data 0 (LSB)  Red-pixel Data: Each red pixel's brightness data consists of these 6 bits pixel data.
+GREEN 5 +GREEN 4 +GREEN 3 +GREEN 2 +GREEN 1 +GREEN 0	Green Data 5 (MSB) Green Data 4 Green Data 3 Green Data 2 Green Data 1 Green Data 0 (LSB)  Green-pixel Data: Each green pixel's brightness data consists of these 6 bits pixel data.
+BLUE 5 +BLUE 4 +BLUE 3 +BLUE 2 +BLUE 1 +BLUE 0	Blue Data 5 (MSB) Blue Data 4 Blue Data 3 Blue Data 2 Blue Data 1 Blue Data 0 (LSB)  Blue-pixel Data: Each blue pixel's brightness data consists of these 6 bits pixel data.
DTCLK	Data Clock: The typical frequency is 65.0 MHz. The signal is used to strobe the pixel data and the DSPTMG .
+DSPTMG(DSP)	When the signal is high, the pixel data shall be valid to be displayed.
VSYNC(V-S)	Vertical Sync: The signal is synchronized to DTCLK . Both active high/low signal acceptable.
HSYNC(H-S)	Horizontal Sync: The signal is synchronized with DTCLK . Both active high/low signals are acceptable.
VDD	Power Supply
GND	Ground
VEEDID	EEDID 3.3 V Power Supply
CLKEDID	EEDID Clock
DataEEDID	EEDID Data

**Note:** Output signals except VEEDID, CLKEDID and DataEEDID from any system shall be Hi-Z state when VDD is off.

**5.3.1 E-EDID**

E-EDID detail in this LCD module is in the following table.

Address (hex)	Description	Data (hex)	Remark
00 - 07	Header	00 FF FF FF FF FF FF 00	Header, Fixed
08 - 09	ID Manufacturer Name	24 94	"IDT"
0A - 0B	ID Product Code	0D 00	Product Code
0C - 0F	ID Serial Number	00 00 00 00	Unused
10	Week of Manufacture	00	Unused
11	Year of Manufacture	00	Unused
12 - 13	EDID Structure Version / Revision	01 03	Ver1.3
14 - 18	Basic Display Parameter / Features	80 1E 17 78 0A	Active Area : 30.41cm x 22.81cm, Gamma : 2.2
19 - 22	Color Characteristics	(Note 1)	
23 - 25	-240Established Timing	00 00 00	Unused
26 - 35	Standard Timing Identification	01 01 01 01 01 01 01 01 01 01 01 01 01 01 01 01	Unused
36 - 47	Detailed Timing / Monitor Description #1	64 19 00 40 41 00 26 30 18 88 36 00 30 E4 10 00 00 18	Typical Timing
48 - 59	Detailed Timing / Monitor Description #2	(Note 1)	
5A - 6B	Detailed Timing / Monitor Description #3	00 00 00 FE 00 49 44 54 0A 20 20 20 20 20 20 20 20	Manufactuerer name "IDT"
6C - 7D	Detailed Timing / Monitor Description #4	00 00 00 FE 00 4E 31 35 30 58 34 0A 20 20 20 20 20	Manufacturer P/N "N150X4"
7E	Extension Flag	-24000	No extension
7F	Checksum	(Note 1)	

Note:

1.Detail data contents shall be determined with concurrence between user and International Display Technology(IDTech).

## 5.4 Interface Signal Electrical Characteristics

### 5.4.1 Signal Electrical Characteristics for LVDS Receiver

The LVDS receiver equipped in this LCD module is compatible with ANSI/TIA/TIA-644 standard.

#### Electrical Characteristics

Parameter	Symbol	Min	Typ	Max	Unit	Conditions
Differential Input High Threshold	V <sub>th</sub>			+100	mV	V <sub>cm</sub> =+1.2V
Differential Input Low Threshold	V <sub>tl</sub>	-100			mV	V <sub>cm</sub> =+1.2V
Magnitude Differential Input Voltage	V <sub>id</sub>	100		600	mV	
Common Mode Voltage	V <sub>cm</sub>	1.0	1.2	1.5	V	V <sub>th</sub> - V <sub>tl</sub> = 200mV
Common Mode Voltage Offset	ΔV <sub>cm</sub>	-50		+50	mV	V <sub>th</sub> - V <sub>tl</sub> = 200mV

#### Note :

- Input signals shall be low or Hi-Z state when VDD is off.

#### Voltage Definitions

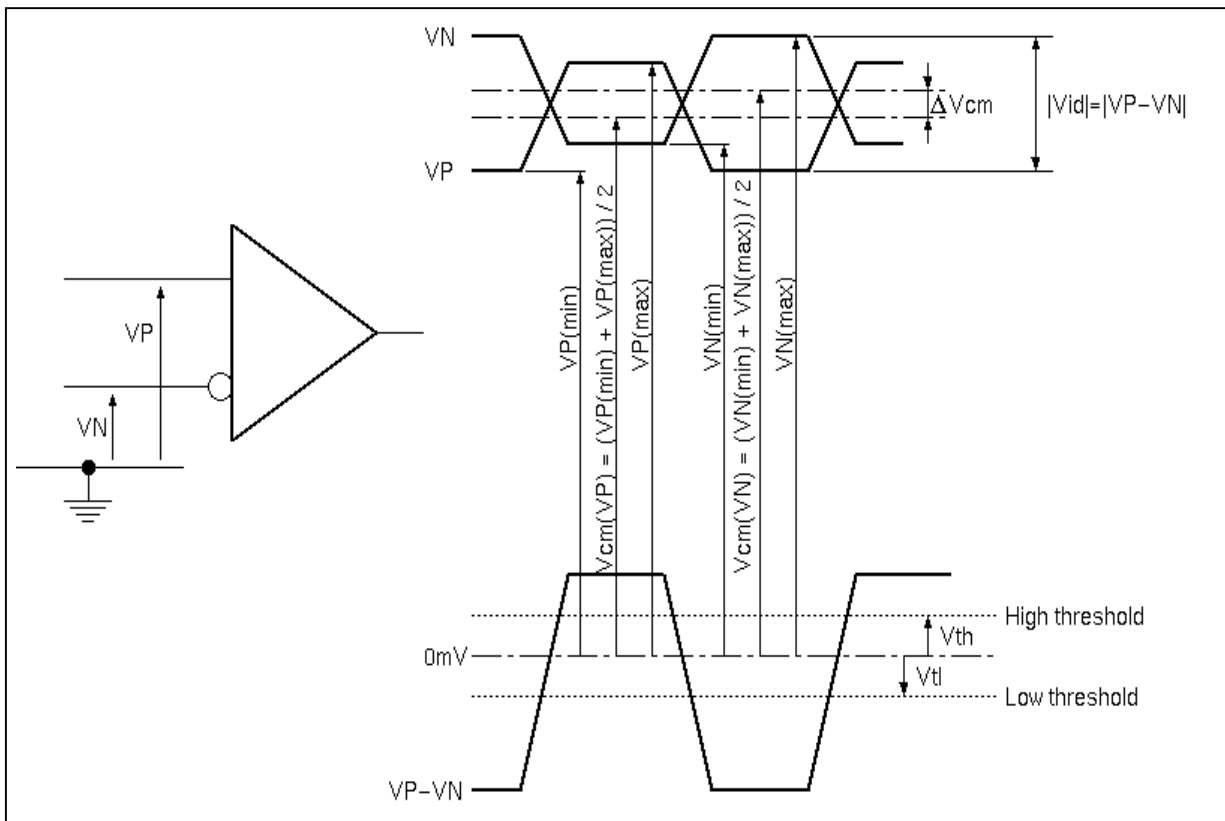

Measurement System

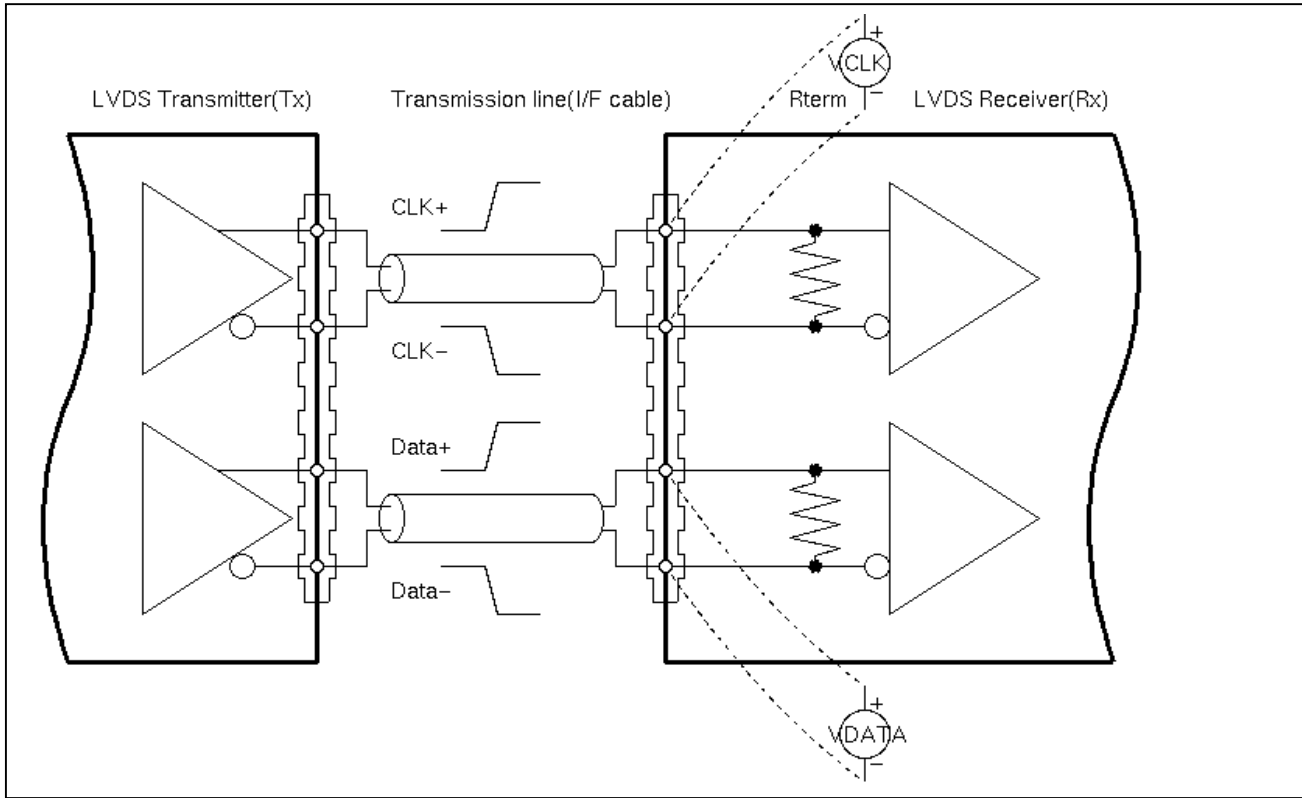

Timing Requirements

Parameter	Symbol	Min	Typ	Max	Unit	Conditions
Clock Frequency	fc	50	65	67	MHz	
Cycle Time	tc	14.93	15.38	20.00	ns	
Data Setup Time (Note 1)	Tsu	500			ps	fc = 65MHz, tCCJ < 50ps, Vth-Vtl = 400mV, Vcm = 1.2V, □Vcm = 0
Data Hold Time (Note 2)	Thd	500			ps	
Cycle-to-cycle jitter (Note 3)	tCCJ	-150		+150	ps	fc = 65MHz, Tsu=Thd=900ps
Cycle Modulation Rate (Note 4)	tCJavg			20	ps/clock	fc = 65MHz, Tsu=Thd=900ps

**Note :**

1. All values are at VDD=3.3V, Ta=25 degree C.
2. See figure "Timing Definition" and "Timing Definition(detail A)" for definition.
3. Jitter is the magnitude of the change in input clock period.
4. This specification defines maximum average cycle modulation rate in peak-to-peak transition within any 100 clock cycles. Figure "Cycle Modulation Rate" illustrates a case against this requirement. This specification is applied only if input clock peak jitter within any 100 clock cycles is greater than 300ps.

Timing Definition

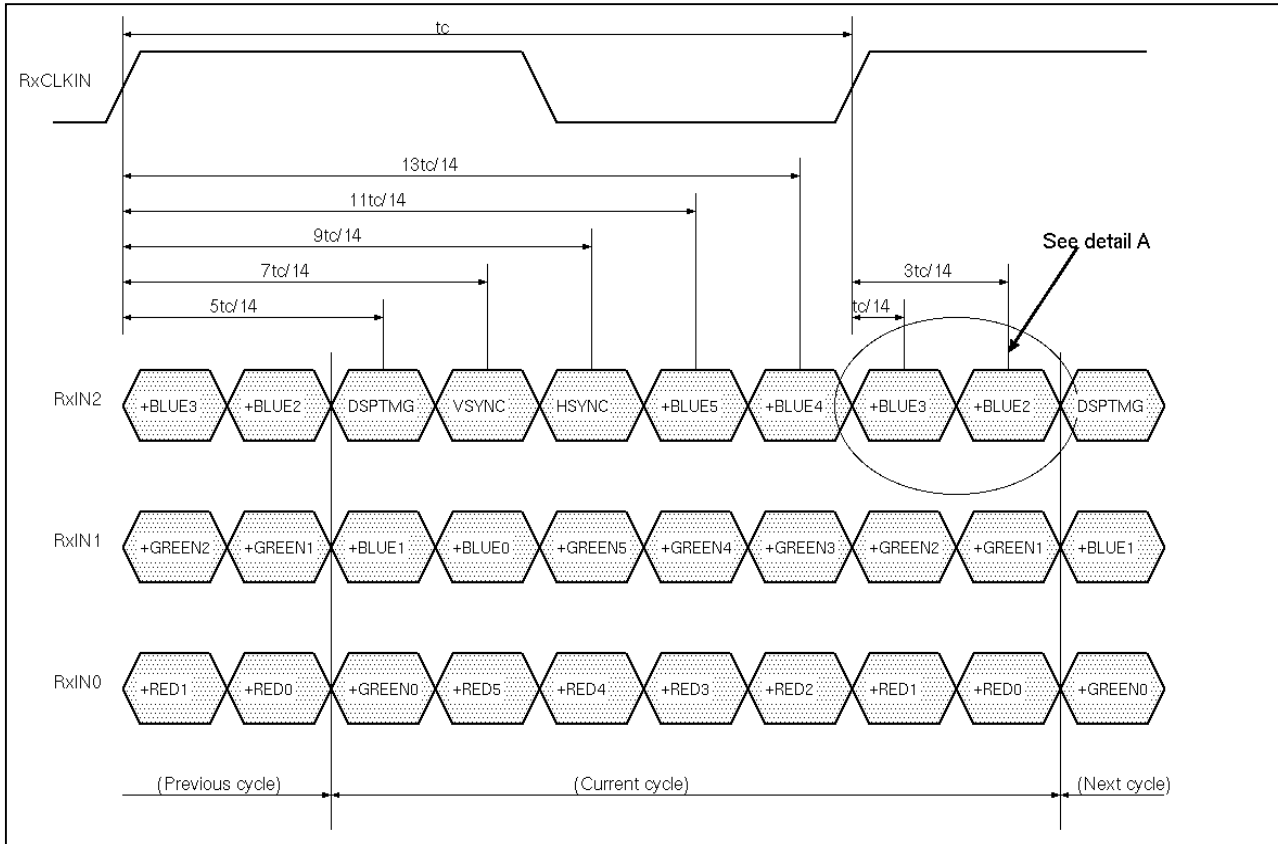



Timing Definition(detail A)

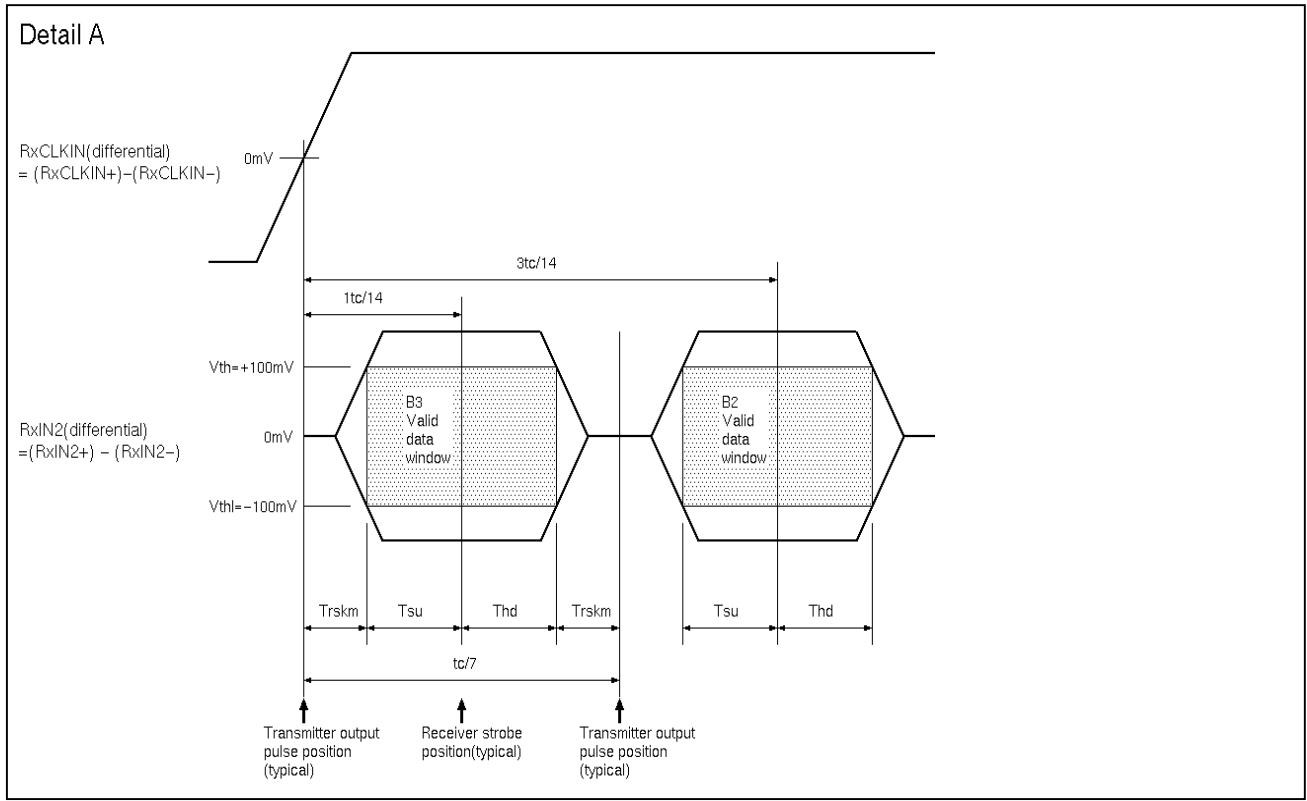

**Note:**  $Tsu$  and  $Thd$  are internal data sampling window of receiver.  $Trskm$  is the system skew margin; i.e., the sum of cable skew, source clock jitter, and other inter-symbol interference, shall be less than  $Trskm$ .

Cycle Modulation Rate

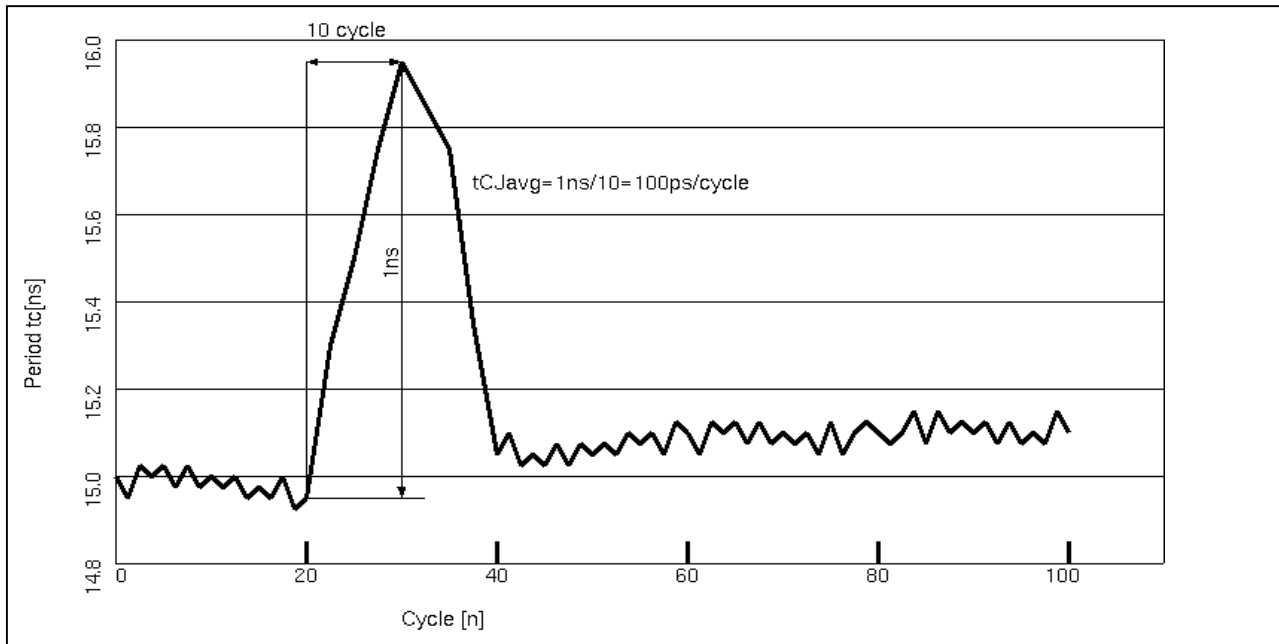

### 5.4.2 LVDS Receiver Internal Circuit

The following figure shows the internal block diagram of the LVDS receiver. This LCD module equips termination resistors for LVDS link.

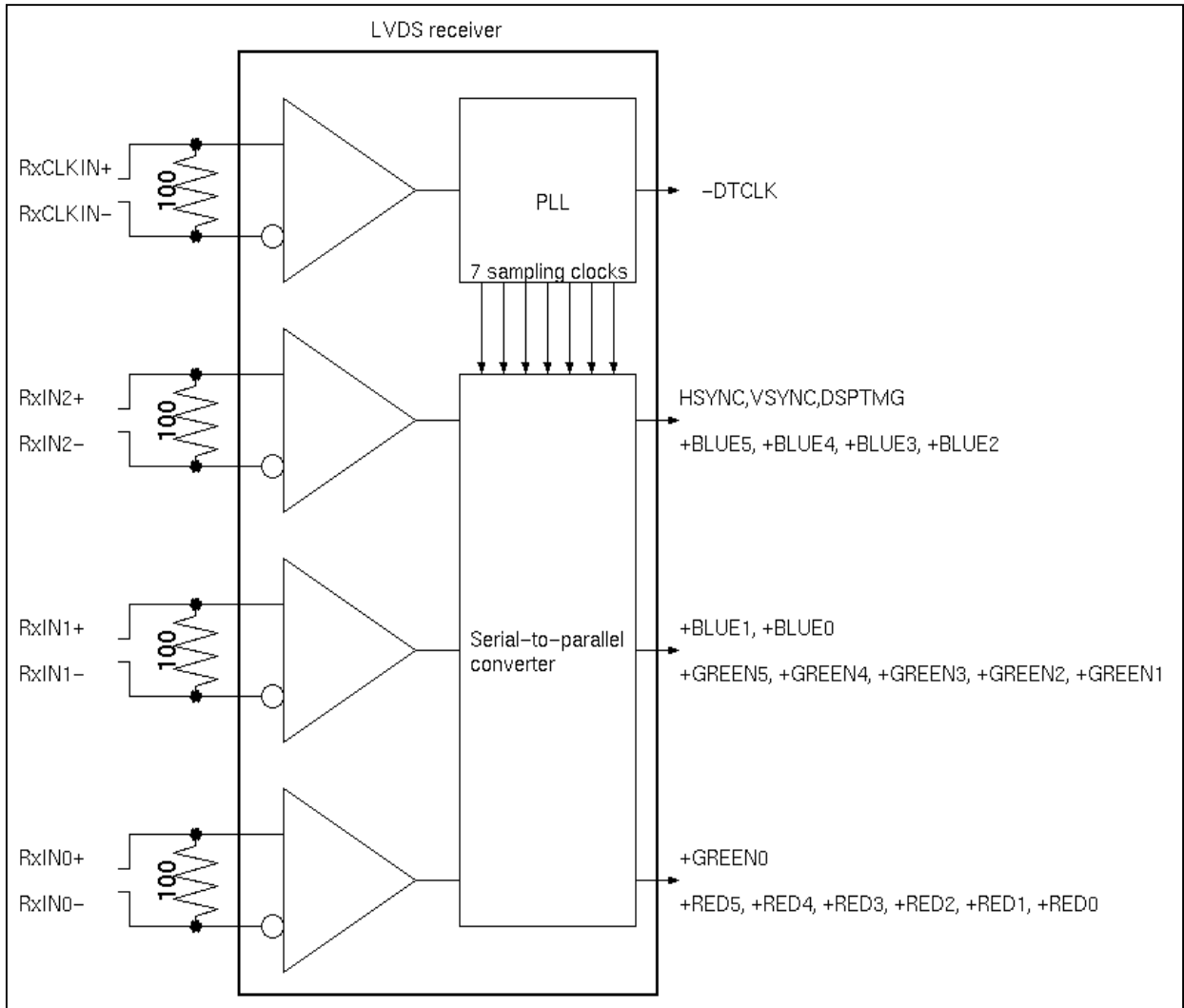

### 5.4.3 Recommended Guidelines for Motherboard PCB Design and Cable Selection

Following the suggestions below will help to achieve optimal results.

- ☐ Use controlled impedance media for LVDS signals. They should have a matched differential impedance of 100 ohm.
- ☐ Match electrical lengths between traces to minimize signal skew.
- ☐ Isolate TTL signals from LVDS signals.
- ☐ For cables, twisted pair, twin, or flex circuit with close coupled differential traces are recommended.



## 5.5 Signal for Lamp Connector

Pin #	Signal Name
1	Lamp High Voltage
2	Lamp Low Voltage

## 6.0 Pixel format image

Following figure shows the relationship of the input signals and LCD pixel format image. Even and odd pair of RGB data are sampled at a time.

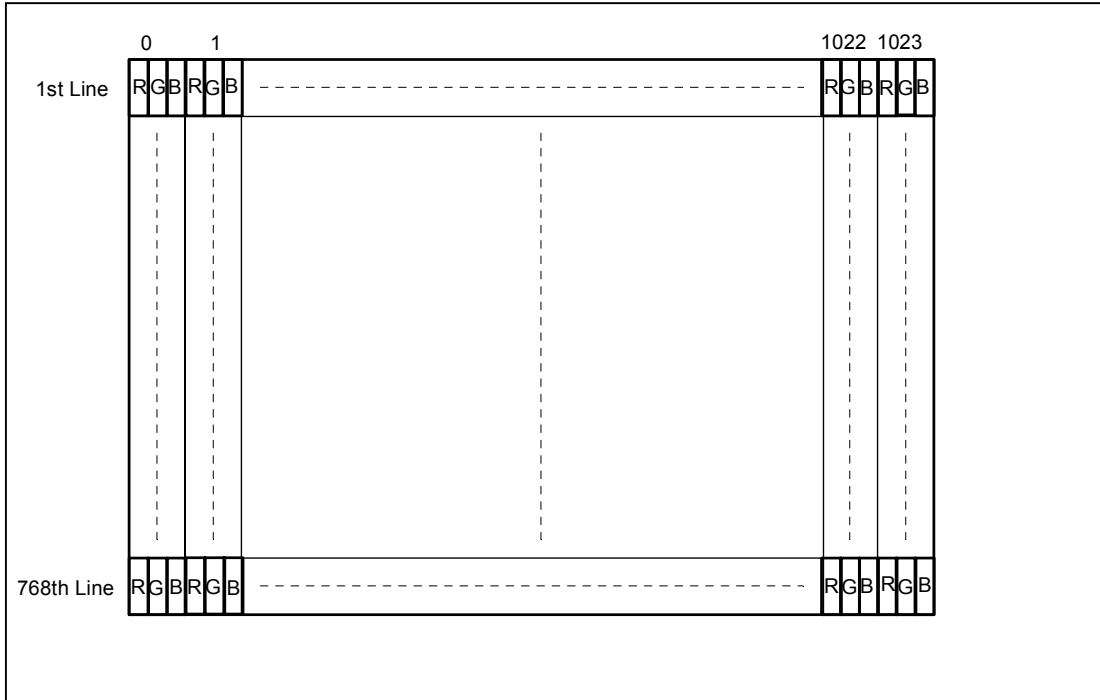



## 7.0 Parameter guide line for CFL Inverter

SYMBOL	PARAMETER	MIN	D.P (Note 1)	MAX	UNITS	CONDITION
(L63)	White Luminance (Center)	- -	215	- -	[cd/m <sup>2</sup> ]	Ta=25[deg. C]
ICFL	CFL current	3.0	6.5	7.0	[mArms]	Ta=25[deg. C] <b>(Note 2,5)</b>
ICFLP	CFL Peak Inrush Current			20	[mA]	Ta=25[deg. C] <b>(Note 2,6)</b>
FCFL	CFL Frequency	40		70	[kHz]	Ta=25[deg. C] <b>(Note 3)</b>
VCFLi	Inverter Ignition Voltage	1,600			[Vrms]	Ta=0[deg. C]
VCFL	CFL Voltage (Reference)		630		[Vrms]	Ta=25[deg. C]
PCFL	CFL Power consumption		4.1	4.5	[W]	Ta=25[deg. C] <b>(Note 4)</b>

**Note :**

1. Design Point
2. If it exceeds MIN/MAX values, then "CFL Life", "ON/OFF Cycle", and "SAFETY" will not be guaranteed.
3. CFL Frequency should be carefully determined to avoid interference between inverter and TFT LCD.
4. Calculated value for reference (ICFL x VCFL = PCFL).
5. It should be employed the inverter which has `Duty Dimming`, if ICFL is less than 4[mA].
6. Duration: 50msec MAX



The following chart is Luminance versus Lamp Current for your reference.





## 8.0 Interface Timings

Basically, interface timings should match the VESA 1024x768 / 60 Hz (VG901101) manufacturing guide line timing. These timings described here are not actual input timings of LCD module but output timings of SN75LVDS86DGG(Texas Instruments) or equivalent.

### 8.1 Timing Characteristics

Symbol		MIN	TYP	MAX	Unit	Note
fdck	DTCLK Frequency	50.00	65.00	67.00	MHz	
tck	DTCLK cycle time	14.93	15.38	20.00	nsec	
tx	X total time	1206	1344	2047	tck	
tacx	X active time	1024	1024	1024	tck	
Hsync	H frequency		48.363		KHz	
Hsw	H-Sync width	8	136		tck	2
Hbp	H back porch	8	160	510	tck	2
Hfp	H front porch	0	24		tck	
ty	Y total time	777	806	1023	tx	
tacy	Y active time	768	768	768	tx	
Vsync	Frame rate	55	60	61	Hz	
Vw	V-sync Width	1	6		tx	
Vfp	V-sync front porch	1	3		tx	
Vbp	V-sync back porch	7	29	63	tx	1

**Note1** : Vbp should be static.

**Note2** :  $Hsw + Hbp \geq 32$  [tck]

- The timing interval between V-Sync falling edge and H-Sync rising edge should be fixed between each V-Frame.(V-Sync and H-Sync polarity are assumed to be positive in this case.)

## 8.2 Timing Definition

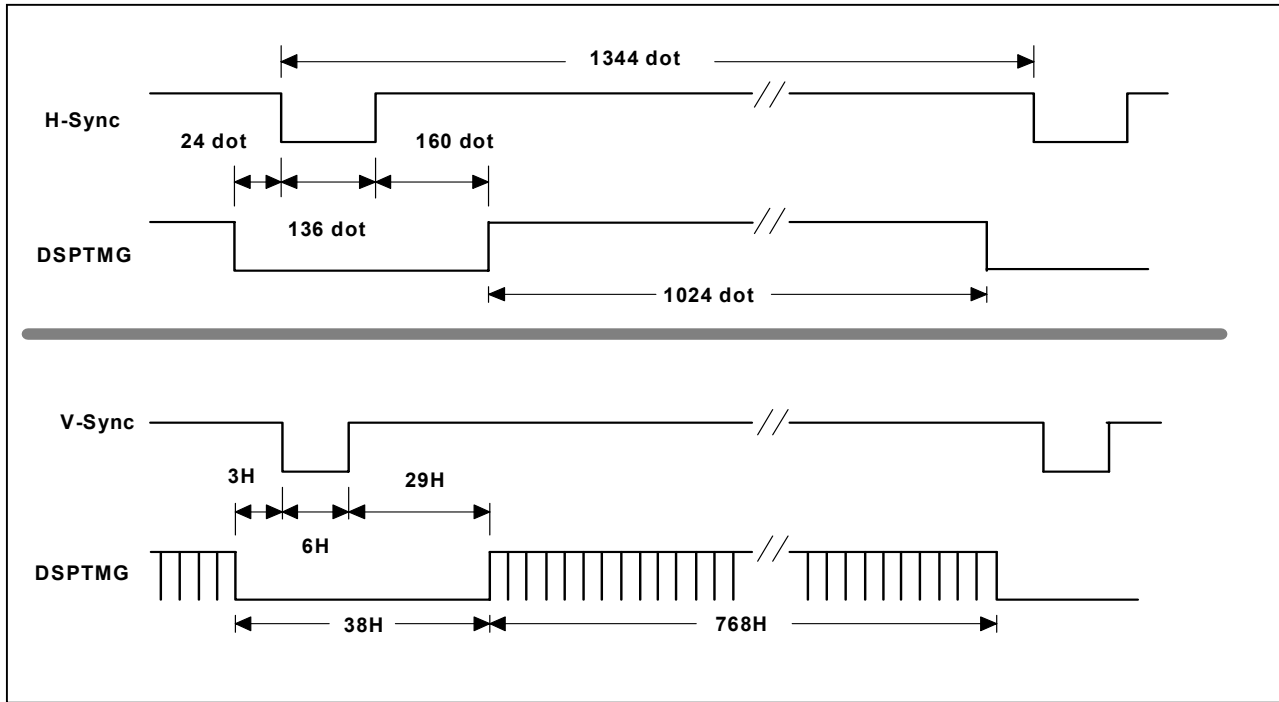





## 9.0 Power Consumption

Input power specifications are as follows;

SYMBOL	PARAMETER	Min	Typ	Max	UNITS	CONDITION
VDD	Logic/LCD Drive Voltage	3.0	3.3	3.6	[V]	Load Capacitance 20[uF]
PDD	VDD Power		1.6 <b>(TBD)</b>		[W]	All Black Pattern VDD=3.3[V]
				2.2 <b>(TBD)</b>	[W]	Max. Pattern, VDD=3.6[V]
IDD	VDD Current		490 <b>(TBD)</b>		[mA]	All Black Pattern, VDD=3.3[V]
				640 <b>(TBD)</b>	[mA]	Max Pattern, VDD=3.0[V]
VDDrp	Allowable Logic/LCD Drive Ripple Voltage			100	[mVp-p]	

## 10.0 Power ON/OFF Sequence

VDD power and lamp on/off sequence is as follows. Interface signals are also shown in the chart. Signals from any system shall be Hi-Z state or low level when VDD is off.

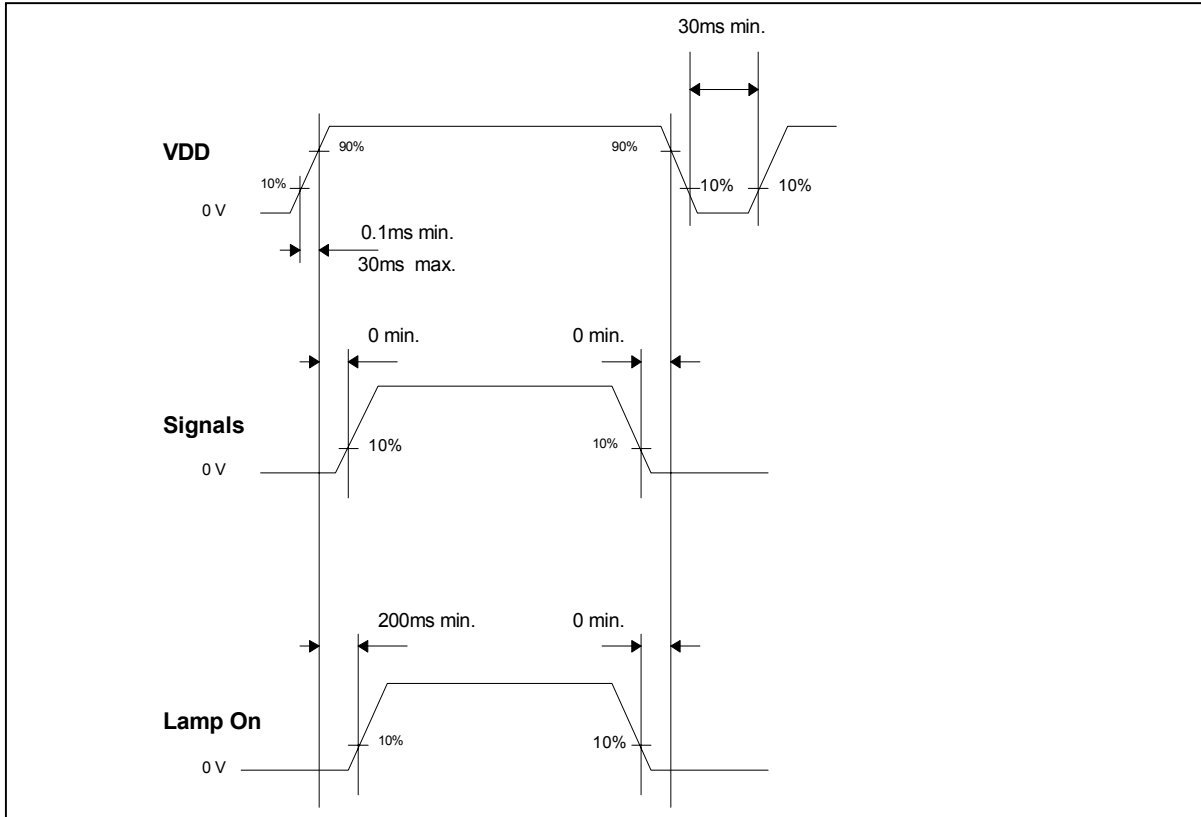

# 11.0 Mechanical Characteristics

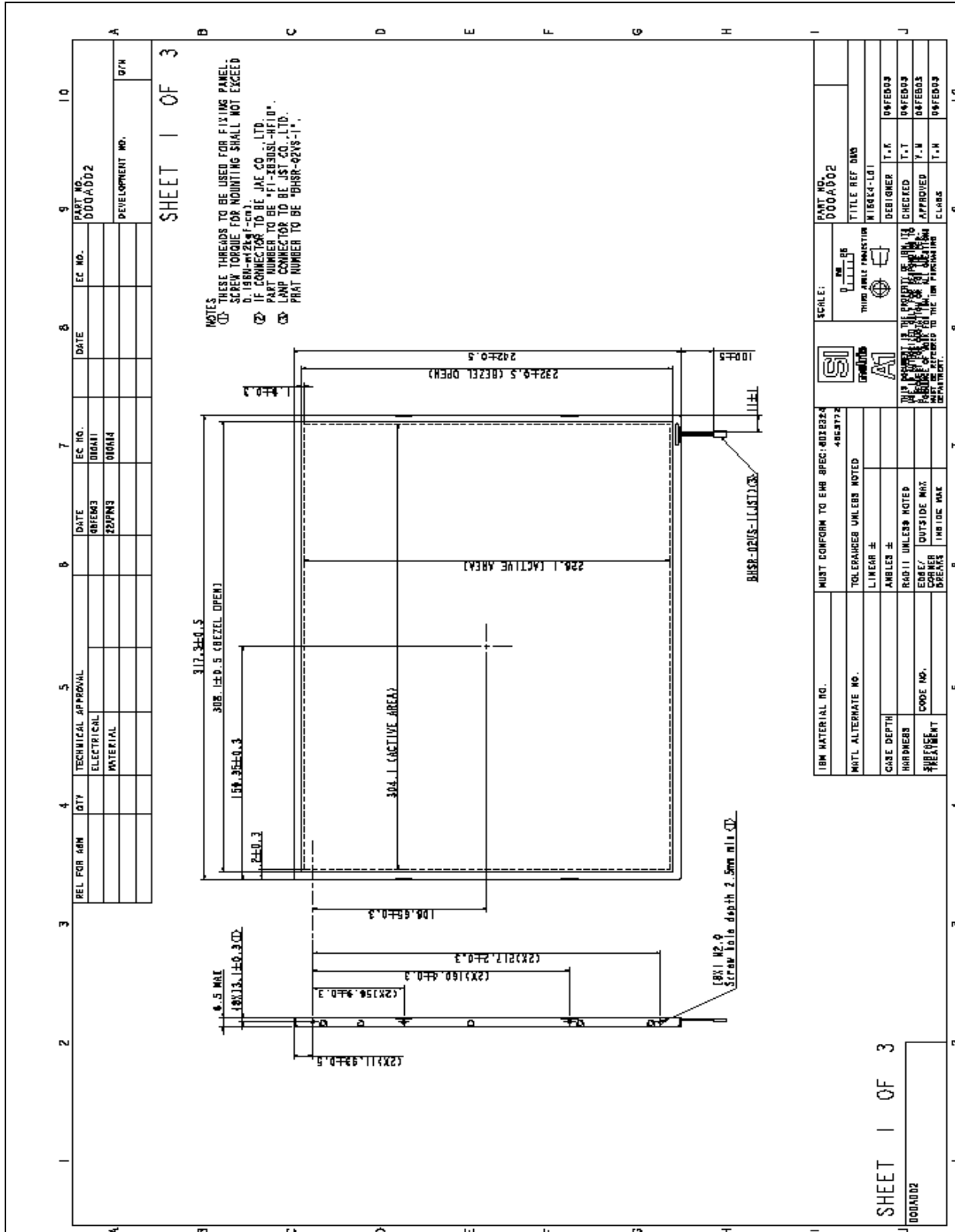

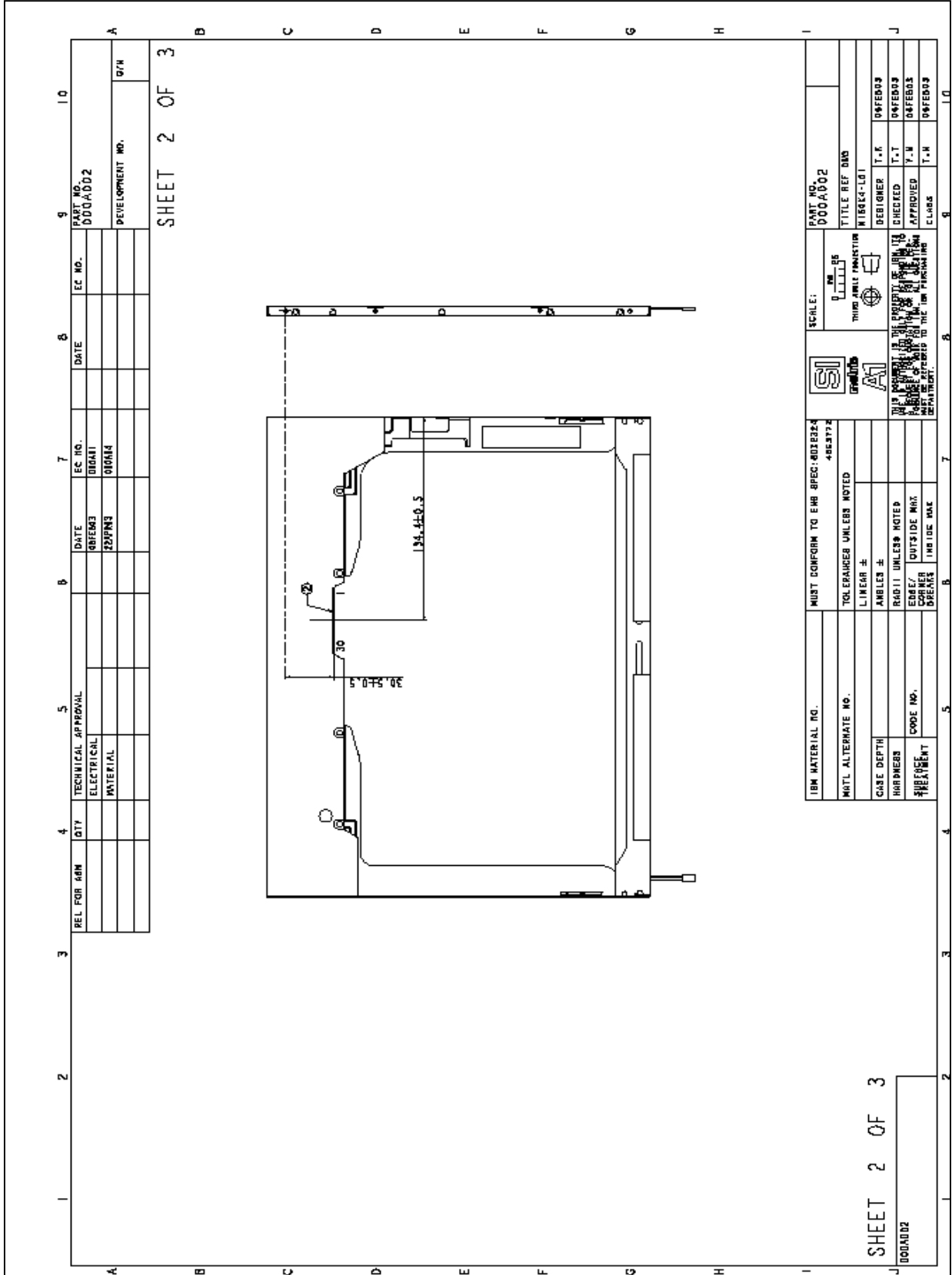

1	2	3	4	5	6	7	8	9	10	
A	B	C	D	E	F	G	H	I	J	
REL FOR DIM ELECTRICAL MATERIAL			TECHNICAL APPROVAL DATE INITIALS		EC NO. DATE INITIALS		EC NO. DATE INITIALS		PART NO. 000A002 DEVELOPMENT NO. 0/0	
SHEET 3 OF 3										
HISTORY 000A01: Initial Release 000A04: Part No. 000A300 was changed to 000D300. (The cable length of LAMP ASM is changed to 100mm from 60mm.)										
IBM MATERIAL NO. 468372			MUST CONFORM TO ENR SPEC: 802828-4 468372			SCALE: 1:1 THIRD ANGLE PROJECTION		PART NO. 000A002 TITLE REF AND NUMBER-L01		DESIGNER T.R 04FEB03
MATL ALTERNATE NO.			TOLERANCES UNLESS NOTED LINEAR ± ANGLES ±			CHECKED T.T 04FEB03		APPROVED T.W 04FEB03		CLARK T.W 04FEB03
CASE DEPTH HARDNESS SURFACE TREATMENT			RADIUS UNLESS NOTED EDGE/ CORNER BREAKS			INSIDE MAX INSIDE MAX		T.N 04FEB03		T.N 04FEB03
SHEET 3 OF 3 000A02										



## 12.0 National Test Lab Requirement

The display module will satisfy all requirements for compliance to

UL 60950, 3rd Edition

CAN/CSA-C22.2 No. 60950-00

IEC 60950 (3rd. Ed.)

EN 60950 (3rd. Ed.)

U.S.A. Information Technology Equipment

Canada, Information Technology Equipment

International, Information Technology Equipment

International, Information Technology Equipment  
(European Norm for IEC60950)

\*\*\*\*\* End Of Page \*\*\*\*\*