

## TFT LCD Approval Specification

**MODEL NO.: N156B3**

**Suffix:-L0B**

Customer : \_\_\_\_\_ ASUS \_\_\_\_\_

Approved by : \_\_\_\_\_

Note :

核准時間	部門	審核	角色	投票
2010-06-22 14:23:38	NB 產品管理處		Director	Accept

**- CONTENTS -**

REVISION HISTORY	-----	3
1. GENERAL DESCRIPTION	-----	4
1.1 OVERVIEW		
1.2 FEATURES		
1.3 APPLICATION		
1.4 GENERAL SPECIFICATIONS		
1.5 MECHANICAL SPECIFICATIONS		
2. ABSOLUTE MAXIMUM RATINGS	-----	5
2.1 ABSOLUTE RATINGS OF ENVIRONMENT		
2.2 ELECTRICAL ABSOLUTE RATINGS		
3. ELECTRICAL CHARACTERISTICS	-----	7
3.1 TFT LCD MODULE		
3.2 BACKLIGHT UNIT		
4. BLOCK DIAGRAM	-----	11
4.1 TFT LCD MODULE		
4.2 BACKLIGHT UNIT		
5. INPUT TERMINAL PIN ASSIGNMENT	-----	12
5.1 TFT LCD MODULE		
5.2 TIMING DIAGRAM OF LVDS INPUT SIGNAL		
5.3 COLOR DATA INPUT ASSIGNMENT		
5.4 EDID DATA STRUCTURE		
6. INTERFACE TIMING	-----	18
6.1 INPUT SIGNAL TIMING SPECIFICATIONS		
6.2 POWER ON/OFF SEQUENCE		
7. OPTICAL CHARACTERISTICS	-----	20
7.1 TEST CONDITIONS		
7.2 OPTICAL SPECIFICATIONS		
8. PRECAUTIONS	-----	24
8.1 HANDLING PRECAUTIONS		
8.2 STORAGE PRECAUTIONS		
8.3 OPERATION PRECAUTIONS		
9. PACKING	-----	25
9.1 CARTON		
9.2 PALLET		
10. DEFINITION OF LABELS	-----	27
10.1 CMO MODULE LABEL		
10.2 CARTON LABEL		
11. MECHANICAL DRAWING	-----	29

**REVISION HISTORY**

Version	Date	Page (New)	Section	Description
Ver. 1.0	Jan.08, 2010	All	All	Preliminary spec 1.0 was first issued for N156B3-L0B
		4	1.5	Update module weight
		7	3.1	Update Power Supply Current and EBL
		18	6.1	Update input signal timing
		25	9.1	Update carton drawing
		20	7.2	Update optical spec
Ver. 2.0	Jan.18, 2010	20	7.2	Update optical characteristic
		25	9.1	Update carton drawing
Ver. 3.0	Jan.29, 2010	All	All	Approval spec 3.0 is first issued
Ver. 3.1	Jun.2, 2010	26	9	Update package drawing

## 1. GENERAL DESCRIPTION

### 1.1 OVERVIEW

N156B3-L0B is a 15.6" (15.547" diagonal) TFT Liquid Crystal Display module with CCFL Backlight unit and 30 pins LVDS interface. This module supports 1366 x 768 HD mode and can display 262,144 colors.

The optimum viewing angle is at 6 o'clock direction.

### 1.2 FEATURES

- HD (1366 x 768 pixels) resolution
- 3.3V LVDS (Low Voltage Differential Signaling) interface
- CCFL

### 1.3 APPLICATION

- TFT LCD Notebook

### 1.4 GENERAL SPECIFICATIONS

Item	Specification	Unit	Note
Active Area	344.232 (H) x 193.536 (V) (15.547" diagonal)	mm	(1)
Bezel Opening Area	349.58 (H) x 198.4 (V)	mm	
Driver Element	a-si TFT active matrix	-	-
Pixel Number	1366 x R.G.B. x 768	pixel	-
Pixel Pitch	0.252 (H) x 0.252 (V)	mm	-
Pixel Arrangement	RGB vertical stripe	-	-
Display Colors	262,144	color	-
Transmissive Mode	Normally white	-	-
Surface Treatment	Hard coating (3H), Glare	-	-
Backlight Unit	1 CCFL		
Power Consumption	5.376 typ/5.475 max@Black Pattern	Watt	
RoHS	Yes		

### 1.5 MECHANICAL SPECIFICATIONS

Item	Min.	Typ.	Max.	Unit	Note	
Module Size	Horizontal(H)	358.8	359.3	359.8	mm	(1)
	Vertical(V)	209	209.5	210	mm	
	Thickness(T)	-	5.9	6.2	mm	
Weight	---	465	480	g	-	

Note (1) Please refer to the attached drawings for more information of front and back outline dimensions.

## 2. ABSOLUTE MAXIMUM RATINGS

### 2.1 ABSOLUTE RATINGS OF ENVIRONMENT

Item	Symbol	Value		Unit	Note
		Min.	Max.		
Storage Temperature	T <sub>ST</sub>	-20	+60	°C	(1)
Operating Ambient Temperature	T <sub>OP</sub>	0	+50	°C	(1), (2)

Note (1) Temperature and relative humidity range is shown in the figure below.

- (a) 90 %RH Max. ( $T_a \leq 40$  °C).
- (b) Wet-bulb temperature should be 39 °C Max. ( $T_a > 40$  °C).
- (c) No condensation.

Note (2) The temperature of panel display surface area should be 0 °C Min. and 60 °C Max.

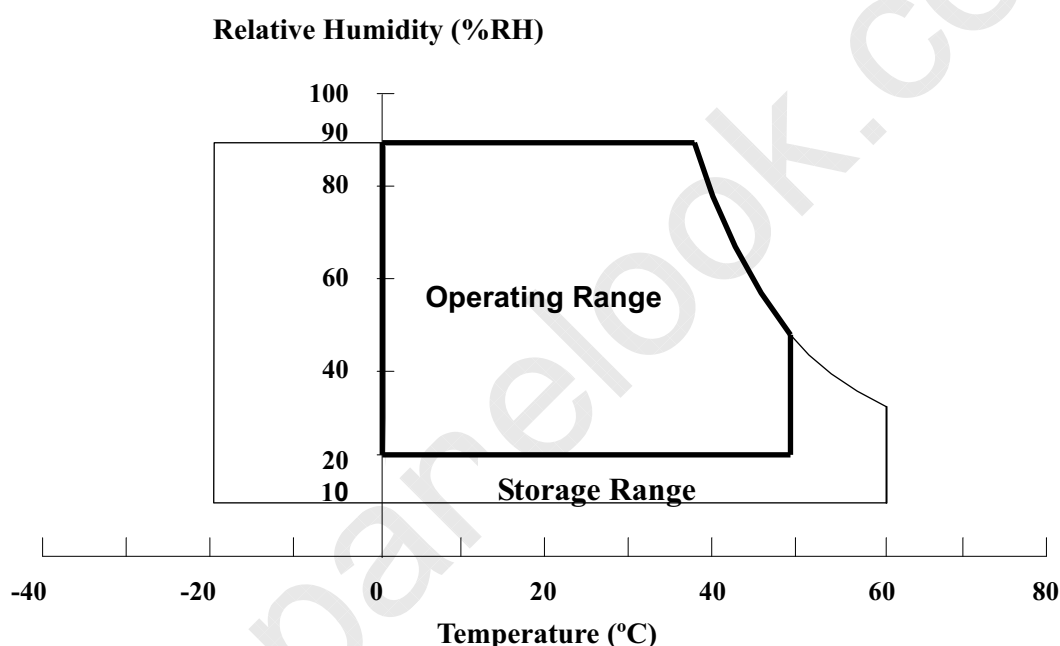

### 2.2 Reliability Test

No.	Test Item	Test Condition	Note
1	High Temperature Storage	60°C, 240 hours	(1) (2)
2	Low Temperature Storage	-20°C, 240 hours	
3	Thermal Shock Storage	[(-20°C 30min)→(60°C 30min)]/cycle, 100cycles	
4	High Temperature Operating	50°C, 300 hours	
5	Low Temperature Operating	0°C, 300 hours	
6	High Temperature & High Humidity Operating	50°C, 80% RH, 300hours	
7	High Temperature & High Humidity Storage	40°C, 90% RH, 240hours	
8	Shock (Non-Operating)	220G, 2ms	(3)(5)
9	Vibration (Non-Operating)	1.5G, 10 to 500 Hz	(4)(5)

10	ESD test (Operation)	150pF/330Ω Contact Discharge : ±8KV	(6)
		150pF/330Ω Air Discharge : ±15KV	

Note (1) There should be no condensation on the surface of panel during test.

Note (2) Temperature of panel display surface area should be 60 °C Max.

Note (3) 1 time for ± X, ± Y, ± Z. for Condition (220G / 2ms) is half Sine Wave

Note (4) 10 ~ 500 Hz, Sine wave, 30 min/cycle, 1 cycle for each X, Y, Z axis

Note (5) At testing Vibration and Shock, the fixture in holding the module has to be hard and rigid enough so that the module would not be twisted or bent by the fixture. The fixing condition is shown as below:

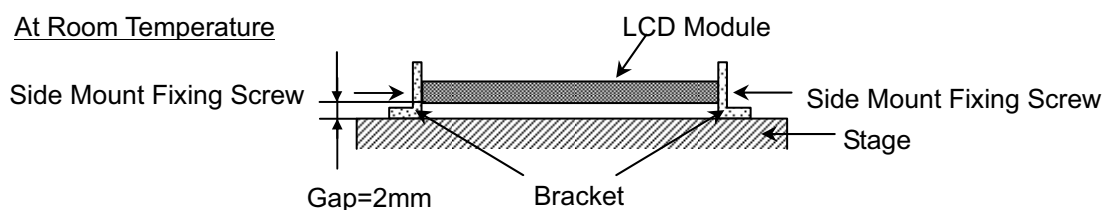

Note (6) According to IEC 61000-4-2

## 2.3 ELECTRICAL ABSOLUTE RATINGS

### 2.3.1 TFT LCD MODULE

Item	Symbol	Value		Unit	Note
		Min.	Max.		
Power Supply Voltage	V <sub>CCS</sub>	-0.3	+4.0	V	(1)
Logic Input Voltage	V <sub>IN</sub>	-0.3	V <sub>CCS</sub> +0.3	V	

Note (1) Permanent damage to the device may occur if maximum values are exceeded. Function operation should be restricted to the conditions described under Normal Operating Conditions.

### 2.3.2 BACKLIGHT UNIT

Item	Symbol	Value		Unit	Note
		Min.	Max.		
Lamp Voltage	V <sub>L</sub>	--	720	V <sub>RMS</sub>	(1), (2), I <sub>L</sub> = 6.0 mA
Lamp Current	I <sub>L</sub>	--	6	mA <sub>RMS</sub>	
Lamp Frequency	F <sub>L</sub>	40	60	KHz	(1), (2)

Note (1) Permanent damage to the device may occur if maximum values are exceeded. Function operation should be restricted to the conditions described under Normal Operating Conditions.

Note (2) Specified values are for lamp (Refer to Section 3.2 for further information).

### 3. ELECTRICAL CHARACTERISTICS

#### 3.1 TFT LCD MODULE

Ta = 25 ± 2 °C

Parameter	Symbol	Value			Unit	Note	
		Min.	Typ.	Max.			
Power Supply Voltage	VCCS	3.0	3.3	3.6	V	-	
Ripple Voltage	V <sub>RP</sub>	-	50	-	mV	-	
Rush Current	I <sub>RUSH</sub>	-	-	1.5	A	(2)	
Initial Stage Current	I <sub>IS</sub>	-	-	1.0	A	(2)	
Power Supply Current	White	I <sub>CC</sub>	-	210	240	mA	(3)a
	Black		-	320	350	mA	(3)b
LVDS Differential Input High Threshold	V <sub>TH(LVDS)</sub>	-	-	+100	mV	(4), V <sub>CM</sub> =1.2V	
LVDS Differential Input Low Threshold	V <sub>TL(LVDS)</sub>	-100	-	-	mV	(4) V <sub>CM</sub> =1.2V	
LVDS Common Mode Voltage	V <sub>CM</sub>	1.125	-	1.375	V	(4)	
LVDS Differential Input Voltage	V <sub>ID</sub>	100	-	600	mV	(4)	
LVDS Terminating Resistor	R <sub>T</sub>	-	100	-	Ohm	-	
Power per EBL WG	PEBL	-	2.9	-	W	(5)	

Note (1) The ambient temperature is Ta = 25 ± 2 °C.

Note (2) I<sub>RUSH</sub>: the maximum current when VCCS is rising

I<sub>IS</sub>: the maximum current of the first 100ms after power-on

Measurement Conditions: Shown as the following figure. Test pattern: black.

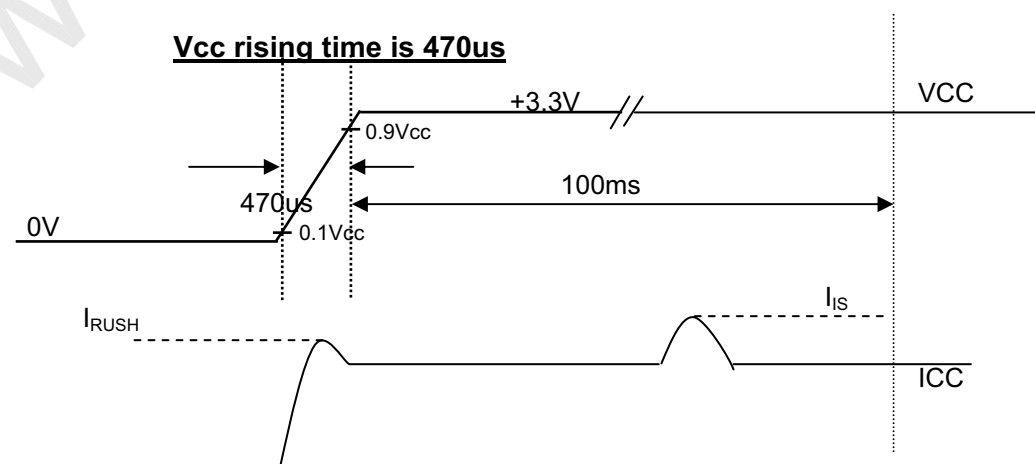
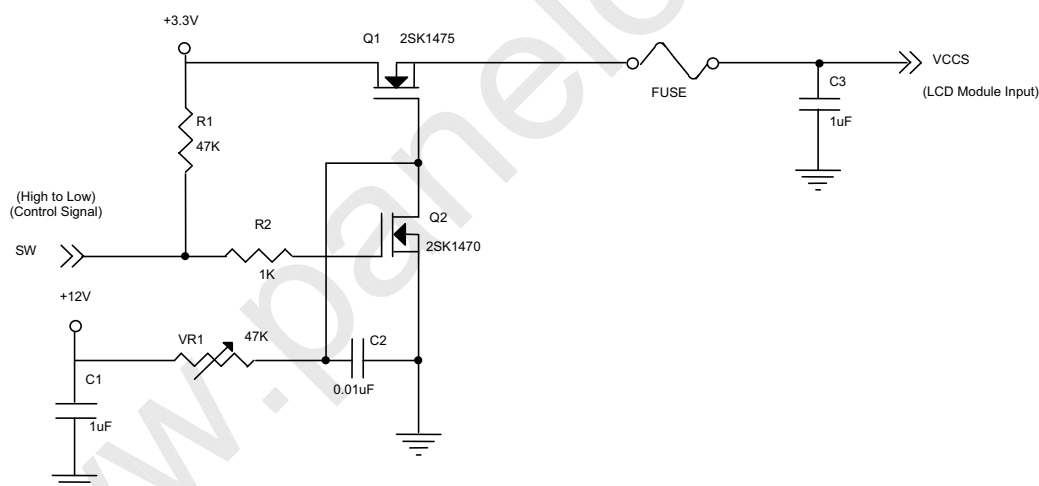

Note (3) The specified power supply current is under the conditions at  $V_{CCS} = 3.3\text{ V}$ ,  $T_a = 25 \pm 2\text{ }^\circ\text{C}$ , DC Current and  $f_v = 60\text{ Hz}$ , whereas a power dissipation check pattern below is displayed.

a. White Pattern



Active Area

b. Black Pattern

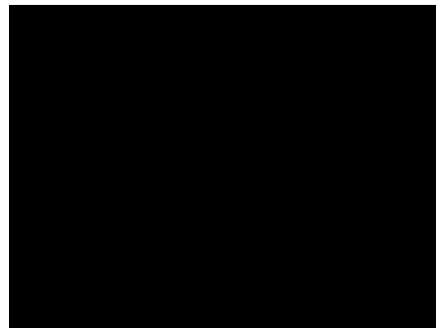

Active Area

Note (4) The specified power are the sum of LCD panel electronics input power and the inverter input power. Test conditions are as follows.

- $V_{cc} = 3.3\text{ V}$ ,  $T_a = 25 \pm 2\text{ }^\circ\text{C}$ ,  $f_v = 60\text{ Hz}$ ,
- The pattern used is a black and white 32 x 36 checkerboard, slide #100 from the VESA file "Flat Panel Display Monitor Setup Patterns", FPDMSU.ppt.
- Luminance: 60 nits.
- The inverter used is provided from Sumida. Please contact them for detail information. CMO doesn't provide the inverter in this product.

Note (5) The parameters of LVDS signals are defined as the following figures.

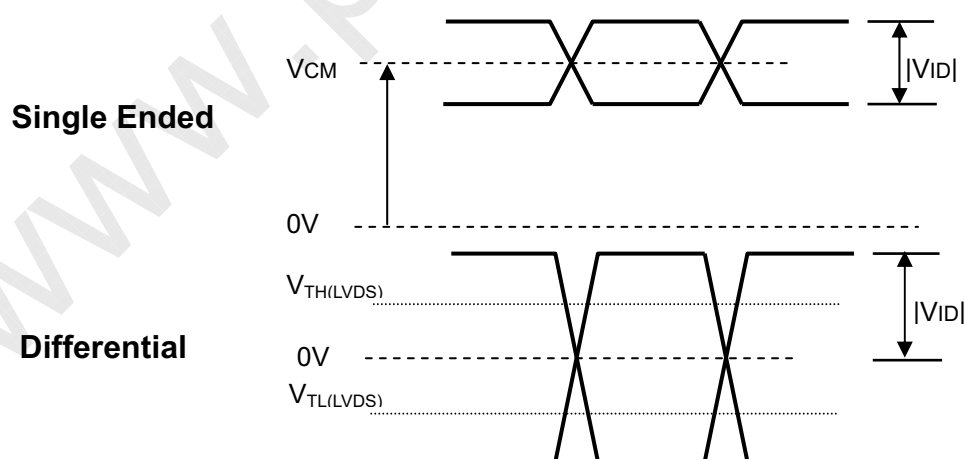



## 3.2 BACKLIGHT UNIT

Ta = 25 ± 2 °C

Parameter	Symbol	Value			Unit	Note
		Min.	Typ.	Max.		
Lamp Input Voltage	V <sub>L</sub>	648	720	792	V <sub>RMS</sub>	I <sub>L</sub> = 6.0 mA
Lamp Current	I <sub>L</sub>	2.0	6.0	7.0	mA <sub>RMS</sub>	(1),(2)
		3.0				(1),(3)
Lamp Turn On Voltage	V <sub>S</sub>	--	--	1300(25 °C)	V <sub>RMS</sub>	(4)
		--	--	1560(0 °C)	V <sub>RMS</sub>	(4)
Operating Frequency	F <sub>L</sub>	40	--	60	KHz	(5)
Lamp Life Time	L <sub>BL</sub>	15,000	--	--	Hrs	(7)
Power Consumption	P <sub>L</sub>	--	4.32	--	W	(6), I <sub>L</sub> = 6.0 mA

Note (1) Lamp current is measured by utilizing a high frequency current meter as shown below:

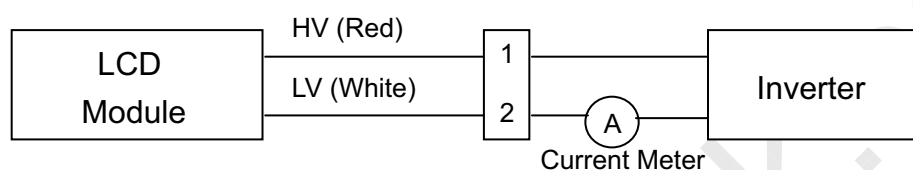

Note (2) for burst mode inverter design

Note (3) for continuous mode inverter design

Note (4) The voltage that must be larger than V<sub>S</sub> should be applied to the lamp for more than 1 second after startup. Otherwise, the lamp may not be turned on normally.

Note (5) The lamp frequency may generate interference with horizontal synchronous frequency from the display, and this may cause line flow on the display. In order to avoid interference, the lamp frequency should be detached from the horizontal synchronous frequency and its harmonics as far as possible.

Note (6) P<sub>L</sub> = I<sub>L</sub> × V<sub>L</sub>

Note (7) The lifetime of lamp is defined as the time when it continues to operate under the conditions at Ta = 25 ± 2 °C and I<sub>L</sub> = 6.0 mA<sub>RMS</sub> until one of the following events occurs:

(a) When the brightness becomes ≤ 50% of its original value.

(b) When the effective ignition length becomes ≤ 80% of its original value. (The effective ignition length is a scope that luminance is over 70% of that at the center point.)

Note (8) The waveform of the voltage output of inverter must be area-symmetric and the design of the inverter must have specifications for the modularized lamp. The performance of the Backlight, such as lifetime or brightness, is greatly influenced by the characteristics of the DC-AC inverter for the lamp. All the parameters of an inverter should be carefully designed to avoid generating too much current leakage from high voltage output of the inverter. When designing or ordering the inverter please make sure that a poor lighting caused by the mismatch of the Backlight and the

inverter (miss-lighting, flicker, etc.) never occurs. If the above situation is confirmed, the module should be operated in the same manners when it is installed in your instrument.

The output of the inverter must have symmetrical (negative and positive) voltage waveform and symmetrical current waveform. (Unsymmetrical ratio is less than 10%) Please do not use the inverter, which has unsymmetrical voltage and unsymmetrical current and spike wave. Lamp frequency may produce interference with horizontal synchronous frequency and as a result this may cause beat on the display. Therefore lamp frequency shall be as away possible from the horizontal synchronous frequency and from its harmonics in order to prevent interference.

Requirements for a system inverter design, which is intended to have a better display performance, a better power efficiency and a more reliable lamp. It shall help increase the lamp lifetime and reduce its leakage current.

- The asymmetry rate of the inverter waveform should be 10% below;
- The distortion rate of the waveform should be within  $\sqrt{2} \pm 10\%$ ;
- The ideal sine wave form shall be symmetric in positive and negative polarities.

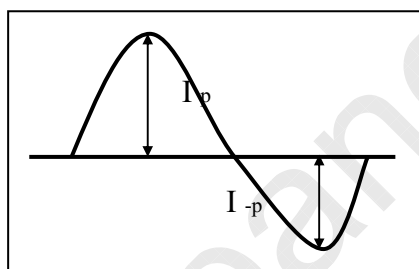

\* Asymmetry rate:

$$|I_p - I_{-p}| / I_{rms} * 100\%$$

\* Distortion rate

$$I_p \text{ (or } I_{-p}) / I_{rms}$$

## 4. BLOCK DIAGRAM

## 4.1 TFT LCD MODULE

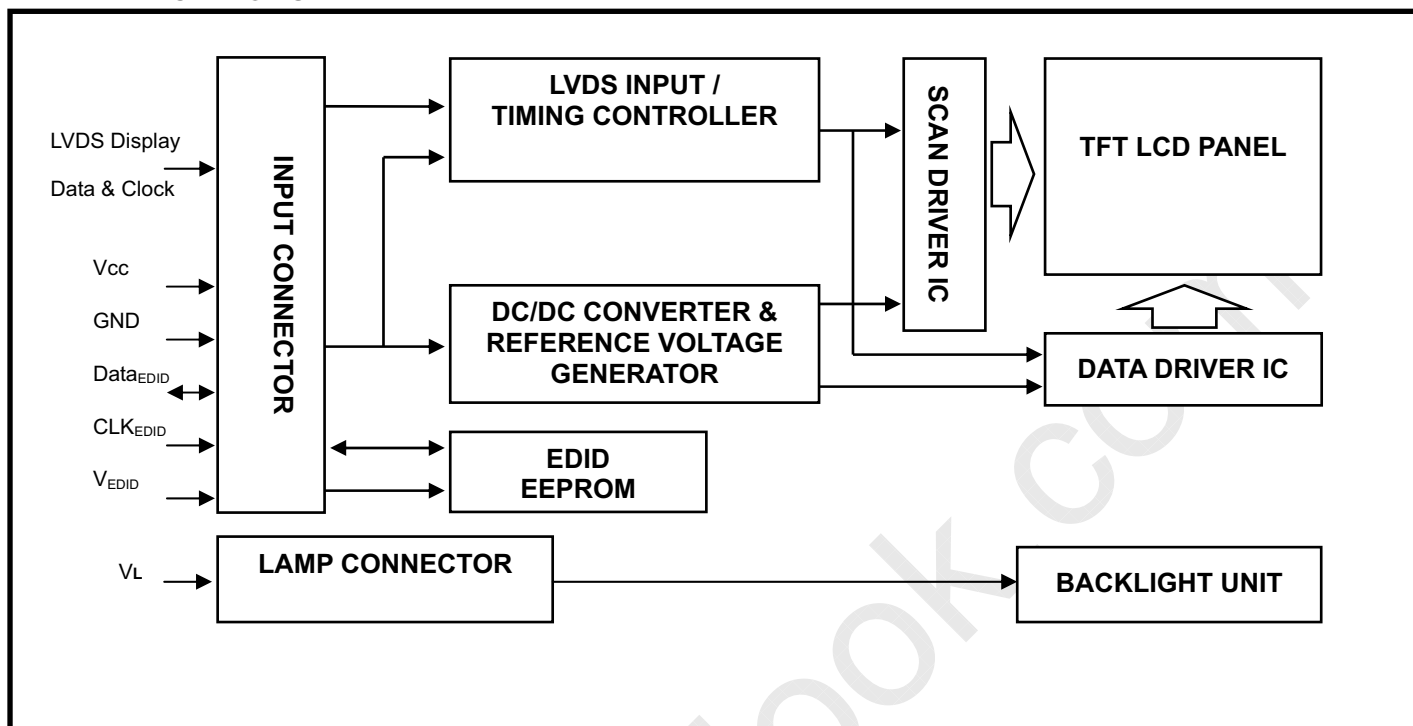

## 4.2 BACKLIGHT UNIT



## 5. INPUT TERMINAL PIN ASSIGNMENT

### 5.1 TFT LCD MODULE

Pin	Symbol	Description	Polarity	Remark
1	Vss	Ground		
2	VCCS	Power Supply (3.3V typ.)		
3	VCCS	Power Supply (3.3V typ.)		
4	VEDID	DDC 3.3V power		
5	TEST	Panel Self Test		
6	CLKEDID	DDC clock		
7	DATAEDID	DDC data		
8	Rxin0-	LVDS differential data input	Negative	R0-R5, G0
9	Rxin0+	LVDS differential data input	Positive	
10	VSS	Ground		
11	Rxin1-	LVDS differential data input	Negative	G1~G5, B0, B1
12	Rxin1+	LVDS differential data input	Positive	
13	VSS	Ground		
14	Rxin2-	LVDS Differential Data Input	Negative	B2-B5,HS,VS, DE
15	Rxin2+	LVDS Differential Data Input	Positive	
16	VSS	Ground		
17	CLK-	LVDS Clock Data Input	Negative	LVDS Level Clock
18	CLK+	LVDS Clock Data Input	Positive	
19	CE	Color Engine Enable Input		
20	NC	No Connection (Reserve)		
21	NC	No Connection (Reserve)		
22	VSS	Ground		
23	NC	No Connection (Reserve)		
24	NC	No Connection (Reserve)		
25	VSS	Ground		
26	NC	No Connection (Reserve)		
27	NC	No Connection (Reserve)		
28	VSS	Ground		
29	NC	No Connection (Reserve)		
30	NC	No Connection (Reserve)		

Note (1) Connector Part No. : 187106-30091 、 093F30-B0T11A

Note (2) User's connector Part No: JAE - FI-X30H or equivalent,

Note (3) The first pixel is odd as shown in the following figure.

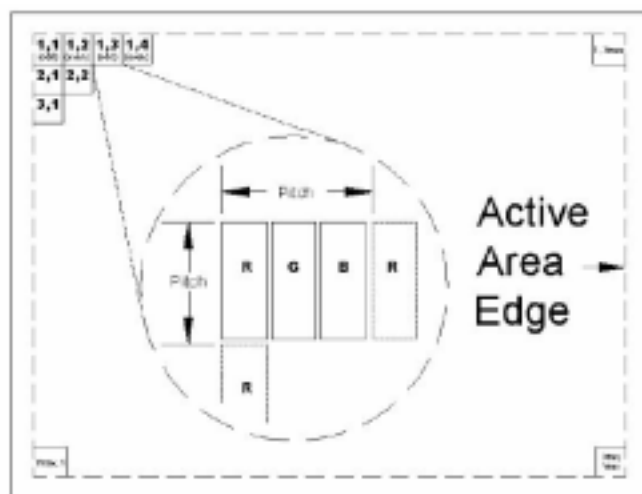

## 5.2 TIMING DIAGRAM OF LVDS INPUT SIGNAL

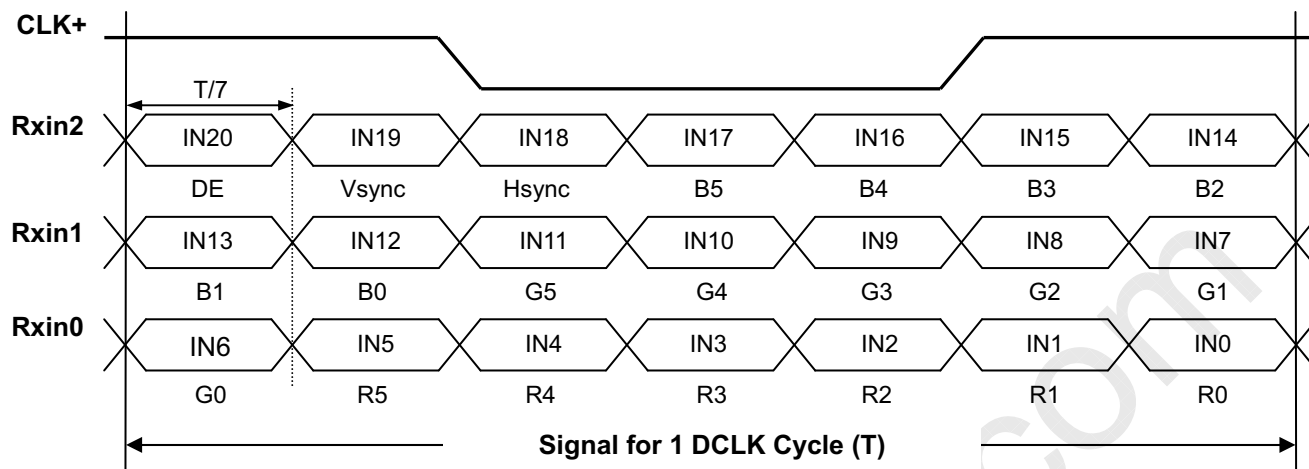

5.3 COLOR DATA INPUT ASSIGNMENT

The brightness of each primary color (red, green and blue) is based on the 6-bit gray scale data input for the color. The higher the binary input the brighter the color. The table below provides the assignment of color versus data input.

Color		Data Signal																	
		Red						Green						Blue					
		R5	R4	R3	R2	R1	R0	G5	G4	G3	G2	G1	G0	B5	B4	B3	B2	B1	B0
Basic Colors	Black	0	0	0	0	0	0	0	0	0	0	0	0	0	0	0	0	0	0
	Red	1	1	1	1	1	1	0	0	0	0	0	0	0	0	0	0	0	0
	Green	0	0	0	0	0	0	1	1	1	1	1	1	0	0	0	0	0	0
	Blue	0	0	0	0	0	0	0	0	0	0	0	0	1	1	1	1	1	1
	Cyan	0	0	0	0	0	0	1	1	1	1	1	1	1	1	1	1	1	1
	Magenta	1	1	1	1	1	1	0	0	0	0	0	0	1	1	1	1	1	1
	Yellow	1	1	1	1	1	1	1	1	1	1	1	1	0	0	0	0	0	0
	White	1	1	1	1	1	1	1	1	1	1	1	1	1	1	1	1	1	1
Gray Scale Of Red	Red(0)/Dark	0	0	0	0	0	0	0	0	0	0	0	0	0	0	0	0	0	0
	Red(1)	0	0	0	0	0	1	0	0	0	0	0	0	0	0	0	0	0	0
	Red(2)	0	0	0	0	1	0	0	0	0	0	0	0	0	0	0	0	0	0
	:	:	:	:	:	:	:	:	:	:	:	:	:	:	:	:	:	:	:
	:	:	:	:	:	:	:	:	:	:	:	:	:	:	:	:	:	:	:
	:	:	:	:	:	:	:	:	:	:	:	:	:	:	:	:	:	:	:
	Red(61)	1	1	1	1	0	1	0	0	0	0	0	0	0	0	0	0	0	0
	Red(62)	1	1	1	1	1	0	0	0	0	0	0	0	0	0	0	0	0	0
Red(63)	1	1	1	1	1	1	0	0	0	0	0	0	0	0	0	0	0	0	
Gray Scale Of Green	Green(0)/Dark	0	0	0	0	0	0	0	0	0	0	0	0	0	0	0	0	0	0
	Green(1)	0	0	0	0	0	0	0	0	0	0	0	1	0	0	0	0	0	0
	Green(2)	0	0	0	0	0	0	0	0	0	0	1	0	0	0	0	0	0	0
	:	:	:	:	:	:	:	:	:	:	:	:	:	:	:	:	:	:	:
	:	:	:	:	:	:	:	:	:	:	:	:	:	:	:	:	:	:	:
	:	:	:	:	:	:	:	:	:	:	:	:	:	:	:	:	:	:	:
	Green(61)	0	0	0	0	0	0	1	1	1	1	0	1	0	0	0	0	0	0
	Green(62)	0	0	0	0	0	0	1	1	1	1	1	0	0	0	0	0	0	0
Green(63)	0	0	0	0	0	0	1	1	1	1	1	1	0	0	0	0	0	0	
Gray Scale Of Blue	Blue(0)/Dark	0	0	0	0	0	0	0	0	0	0	0	0	0	0	0	0	0	0
	Blue(1)	0	0	0	0	0	0	0	0	0	0	0	0	0	0	0	0	0	1
	Blue(2)	0	0	0	0	0	0	0	0	0	0	0	0	0	0	0	0	1	0
	:	:	:	:	:	:	:	:	:	:	:	:	:	:	:	:	:	:	:
	:	:	:	:	:	:	:	:	:	:	:	:	:	:	:	:	:	:	:
	:	:	:	:	:	:	:	:	:	:	:	:	:	:	:	:	:	:	:
	Blue(61)	0	0	0	0	0	0	0	0	0	0	0	1	1	1	1	1	0	1
	Blue(62)	0	0	0	0	0	0	0	0	0	0	0	1	1	1	1	1	1	0
Blue(63)	0	0	0	0	0	0	0	0	0	0	0	1	1	1	1	1	1	1	

Note (1) 0: Low Level Voltage, 1: High Level Voltage

## 5.4 EDID DATA STRUCTURE

The EDID (Extended Display Identification Data) data formats are to support displays as defined in the VESA Plug & Display and FPD standards.

Byte # (decimal)	Byte # (hex)	Field Name and Comments	Value (hex)	Value (binary)
0	0	Header	00	00000000
1	1	Header	FF	11111111
2	2	Header	FF	11111111
3	3	Header	FF	11111111
4	4	Header	FF	11111111
5	5	Header	FF	11111111
6	6	Header	FF	11111111
7	7	Header	00	00000000
8	8	EISA ID manufacturer name ("CMO")	0D	00001101
9	9	EISA ID manufacturer name (Compressed ASCII)	AF	10101111
10	0A	ID product code (N156B3-L0B)	93	10010011
11	0B	ID product code (hex LSB first; N156B3-L0B)	15	00010101
12	0C	ID S/N (fixed "0")	00	00000000
13	0D	ID S/N (fixed "0")	00	00000000
14	0E	ID S/N (fixed "0")	00	00000000
15	0F	ID S/N (fixed "0")	00	00000000
16	10	Week of manufacture (fixed "00H")	08	00001000
17	11	Year of manufacture (fixed "00H")	14	00010100
18	12	EDID structure version # ("1")	01	00000001
19	13	EDID revision # ("3")	03	00000011
20	14	Video I/P definition ("digital")	80	10000000
21	15	Max H image size ("34.42cm")	22	00100010
22	16	Max V image size ("19.35cm")	13	00010011
23	17	Display Gamma (Gamma = "2.2")	78	01111000
24	18	Feature support ("Active off, RGB Color")	0A	00001010
25	19	Red/Green (Rx1, Rx0, Ry1, Ry0, Gx1, Gx0, Gy1, Gy0)	D1	11010001
26	1A	Blue/White (Bx1, Bx0, By1, By0, Wx1, Wx0, Wy1, Wy0)	F5	11110101
27	1B	Red-x (Rx = "0.577")	93	10010011
28	1C	Red-y (Ry = "0.364")	5D	01011101
29	1D	Green-x (Gx = "0.348")	59	01011001
30	1E	Green-y (Gy = "0.563")	90	10010000
31	1F	Blue-x (Bx = "0.151")	26	00100110
32	20	Blue-y (By = "0.116")	1D	00011101
33	21	White-x (Wx = "0.313")	50	01010000
34	22	White-y (Wy = "0.329")	54	01010100
35	23	Established timings 1	00	00000000
36	24	Established timings 2	00	00000000
37	25	Manufacturer's reserved timings	00	00000000
38	26	Standard timing ID # 1	01	00000001
39	27	Standard timing ID # 1	01	00000001
40	28	Standard timing ID # 2	01	00000001

41	29	Standard timing ID # 2	01	00000001
42	2A	Standard timing ID # 3	01	00000001
43	2B	Standard timing ID # 3	01	00000001
44	2C	Standard timing ID # 4	01	00000001
45	2D	Standard timing ID # 4	01	00000001
46	2E	Standard timing ID # 5	01	00000001
47	2F	Standard timing ID # 5	01	00000001
48	30	Standard timing ID # 6	01	00000001
49	31	Standard timing ID # 6	01	00000001
50	32	Standard timing ID # 7	01	00000001
51	33	Standard timing ID # 7	01	00000001
52	34	Standard timing ID # 8	01	00000001
53	35	Standard timing ID # 8	01	00000001
54	36	Detailed timing description # 1 Pixel clock ("69.3MHz", According to VESA CVT Rev1.1)	12	00010010
55	37	# 1 Pixel clock (hex LSB first)	1B	00011011
56	38	# 1 H active ("1366")	56	01010110
57	39	# 1 H blank ("100")	64	01100100
58	3A	# 1 H active : H blank ("1366 :100")	50	01010000
59	3B	# 1 V active ("768")	00	00000000
60	3C	# 1 V blank ("20")	14	00010100
61	3D	# 1 V active : V blank ("768 :20")	30	00110000
62	3E	# 1 H sync offset ("16")	10	00010000
63	3F	# 1 H sync pulse width ("34")	22	00100010
64	40	# 1 V sync offset : V sync pulse width ("2 : 6")	26	00100110
65	41	# 1 H sync offset : H sync pulse width : V sync offset : V sync width ("16: 34 : 2 : 6")	00	00000000
66	42	# 1 H image size ("344 mm")	58	01011000
67	43	# 1 V image size ("193 mm")	C1	11000001
68	44	# 1 H image size : V image size ("344 : 193")	10	00010000
69	45	# 1 H boarder ("0")	00	00000000
70	46	# 1 V boarder ("0")	00	00000000
71	47	# 1 Non-interlaced, Normal, no stereo, Separate sync, H/V pol Negatives	18	00011000
72	48	Detailed timing description # 2	00	00000000
73	49	# 2 Flag	00	00000000
74	4A	# 2 Reserved	00	00000000
75	4B	# 2 FE (hex) defines ASCII string (Model Name "N156B3-L0B", ASCII)	FE	11111110
76	4C	# 2 Flag	00	00000000
77	4D	# 2 1st character of name ("N")	4E	01001110
78	4E	# 2 2nd character of name ("1")	31	00110001
79	4F	# 2 3rd character of name ("5")	35	00110101
80	50	# 2 4th character of name ("6")	36	00110110
81	51	# 2 5th character of name ("B")	42	01000010
82	52	# 2 6th character of name ("3")	33	00110011
83	53	# 2 7th character of name ("-")	2D	00101101
84	54	# 2 8th character of name ("L")	4C	01001100
85	55	# 2 9th character of name ("0")	30	00110000



86	56	# 2 9th character of name ("B")	42	01000010
87	57	# 2 New line character indicates end of ASCII string	0A	00001010
88	58	# 2 Padding with "Blank" character	20	00100000
89	59	# 2 Padding with "Blank" character	20	00100000
90	5A	Detailed timing description # 3	00	00000000
91	5B	# 3 Flag	00	00000000
92	5C	# 3 Reserved	00	00000000
93	5D	# 3 FE (hex) defines ASCII string (Vendor "CMO", ASCII)	FE	11111110
94	5E	# 3 Flag	00	00000000
95	5F	# 3 1st character of string ("C")	43	01000011
96	60	# 3 2nd character of string ("M")	4D	01001101
97	61	# 3 3rd character of string ("O")	4F	01001111
98	62	# 3 New line character indicates end of ASCII string	0A	00001010
99	63	# 3 Padding with "Blank" character	20	00100000
100	64	# 3 Padding with "Blank" character	20	00100000
101	65	# 3 Padding with "Blank" character	20	00100000
102	66	# 3 Padding with "Blank" character	20	00100000
103	67	# 3 Padding with "Blank" character	20	00100000
104	68	# 3 Padding with "Blank" character	20	00100000
105	69	# 3 Padding with "Blank" character	20	00100000
106	6A	# 3 Padding with "Blank" character	20	00100000
107	6B	# 3 Padding with "Blank" character	20	00100000
108	6C	Detailed timing description # 4	00	00000000
109	6D	# 4 Flag	00	00000000
110	6E	# 4 Reserved	00	00000000
111	6F	# 4 FE (hex) defines ASCII string (Model Name "N156B3-L0B", ASCII)	FE	11111110
112	70	# 4 Flag	00	00000000
113	71	# 4 1st character of name ("N")	4E	01001110
114	72	# 4 2nd character of name ("1")	31	00110001
115	73	# 4 3rd character of name ("5")	35	00110101
116	74	# 4 4th character of name ("6")	36	00110110
117	75	# 4 5th character of name ("B")	42	01000010
118	76	# 4 6th character of name ("3")	33	00110011
119	77	# 4 7th character of name ("-")	2D	00101101
120	78	# 4 8th character of name ("L")	4C	01001100
121	79	# 4 9th character of name ("0")	30	00110000
122	7A	# 4 9th character of name ("B")	42	01000010
123	7B	# 4 New line character indicates end of ASCII string	0A	00001010
124	7C	# 4 Padding with "Blank" character	20	00100000
125	7D	# 4 Padding with "Blank" character	20	00100000
126	7E	Extension flag	00	00000000
127	7F	Checksum	76	01110110

## 6. INTERFACE TIMING

### 6.1 INPUT SIGNAL TIMING SPECIFICATIONS

The input signal timing specifications are shown as the following table and timing diagram.

Signal	Item	Symbol	Min.	Typ.	Max.	Unit	Note
DCLK	Frequency	1/Tc	62.38	69.31	72.77	MHz	-
DE	Vertical Total Time	TV	773	788	985	TH	-
	Vertical Active Display Period	TVD	768	768	768	TH	-
	Vertical Active Blanking Period	TVB	TV-TVD	20	TV-TVD	TH	-
	Horizontal Total Time	TH	1412	1466	1708	Tc	-
	Horizontal Active Display Period	THD	1366	1366	1366	Tc	-
	Horizontal Active Blanking Period	THB	TH-THD	100	TH-THD	Tc	-

Note (1) Because this module is operated by DE only mode, Hsync and Vsync are ignored.

#### INPUT SIGNAL TIMING DIAGRAM

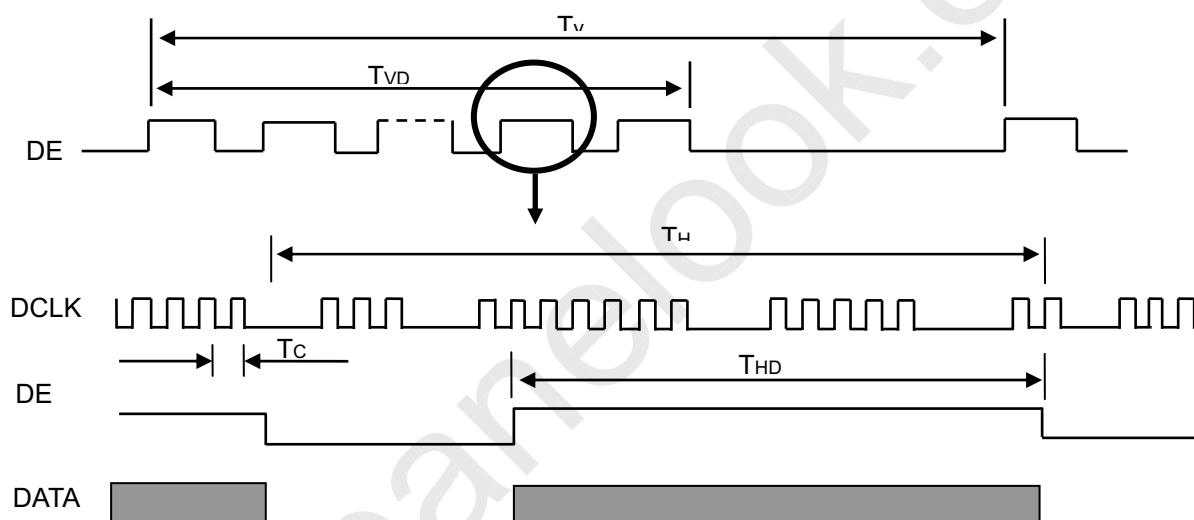

## 6.2 POWER ON/OFF SEQUENCE

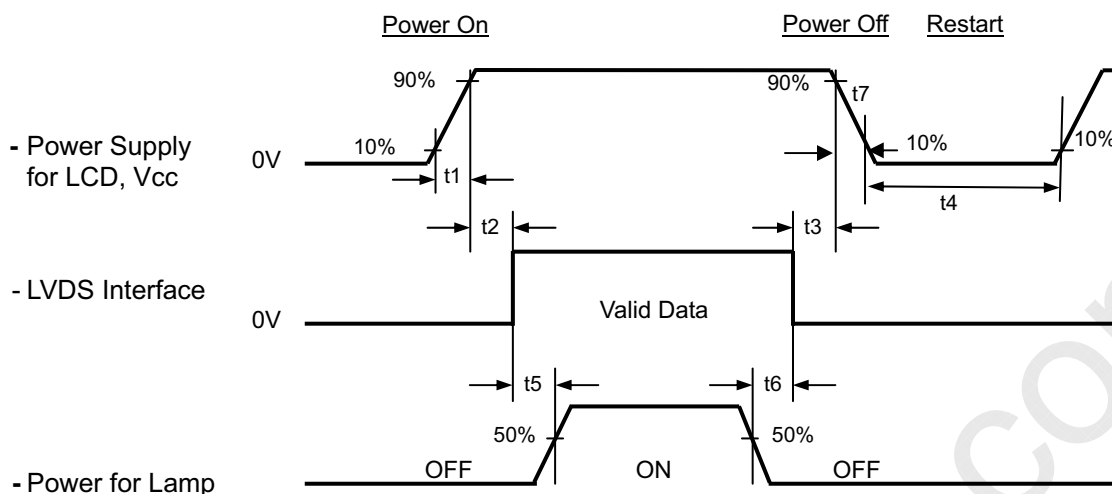

### Timing Specifications:

- $0.5 \leq t1 \leq 10 \text{ ms}$
- $0 \leq t2 \leq 50 \text{ ms}$
- $0 \leq t3 \leq 50 \text{ ms}$
- $t4 \geq 500 \text{ ms}$
- $t5 \geq 200 \text{ ms}$
- $t6 \geq 200 \text{ ms}$

Note (1) Please follow the power on/off sequence described above. Otherwise, the LCD module might be damaged.

Note (2) Please avoid floating state of interface signal at invalid period. When the interface signal is invalid, be sure to pull down the power supply of LCD Vcc to 0 V.

Note (3) The Backlight inverter power must be turned on after the power supply for the logic and the interface signal is valid. The Backlight inverter power must be turned off before the power supply for the logic and the interface signal is invalid.

Note (4) Sometimes some slight noise shows when LCD is turned off (even backlight is already off). To avoid this phenomenon, we suggest that the Vcc falling time is better to follow  $50 \mu\text{s} \leq t7 \leq 300 \text{ ms}$ .

## 7. OPTICAL CHARACTERISTICS

### 7.1 TEST CONDITIONS

Item	Symbol	Value	Unit
Ambient Temperature	Ta	25±2	°C
Ambient Humidity	Ha	50±10	%RH
Supply Voltage	V <sub>CC</sub>	3.3	V
Input Signal	According to typical value in "3. ELECTRICAL CHARACTERISTICS"		
CCFL Input Current	I <sub>L</sub>	6	mA

The measurement methods of optical characteristics are shown in Section 8.2. The following items should be measured under the test conditions described in Section 8.1 and stable environment shown in Note (5).

### 7.2 OPTICAL SPECIFICATIONS

Item		Symbol	Condition	Min.	Typ.	Max.	Unit	Note
Contrast Ratio		CR	$\theta_x=0^\circ, \theta_y=0^\circ$ Viewing Normal Angle	350	500	--	NA	(2), (5) (7)
Response Time		T <sub>R</sub>		--	3	8	ms	(3) (7)
		T <sub>F</sub>		--	7	12	ms	
Average Luminance of White		L <sub>Ave</sub>			160	200	--	cd/m <sup>2</sup>
Color Chromaticity	Red	R <sub>x</sub>	$\theta_x=0^\circ, \theta_y=0^\circ$ Viewing Normal Angle	Typ – 0.03	0.578	Typ + 0.03	NA	(1) (7)
		R <sub>y</sub>			0.339		NA	
	Green	G <sub>x</sub>			0.312		NA	
		G <sub>y</sub>			0.556		NA	
	Blue	B <sub>x</sub>			0.158		NA	
		B <sub>y</sub>			0.149		NA	
	White	W <sub>x</sub>			0.313		NA	
		W <sub>y</sub>			0.329		NA	
Viewing Angle	Horizontal	$\theta_{x+}$	CR≥10	40	45	--	Deg.	(1),(5) (7)
		$\theta_{x-}$		40	45	--		
	Vertical	$\theta_{y+}$		15	20	--		
		$\theta_{y-}$		40	45	--		
White Variation of 5 Points		$\delta W_{5p}$	$\theta_x=0^\circ, \theta_y=0^\circ$	80	90	--	%	(5),(6) (7)

Note (1) Definition of Viewing Angle ( $\theta_x$ ,  $\theta_y$ ):

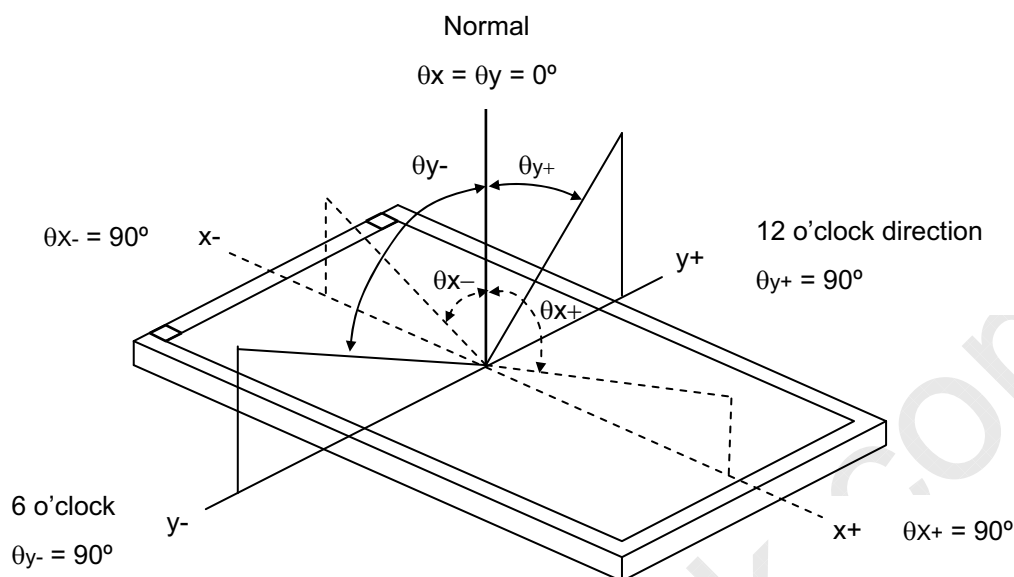

Note (2) Definition of Contrast Ratio (CR):

The contrast ratio can be calculated by the following expression.

$$\text{Contrast Ratio (CR)} = L_{63} / L_0$$

L63: Luminance of gray level 63

L 0: Luminance of gray level 0

$$\text{CR} = \text{CR} (1)$$

CR (X) is corresponding to the Contrast Ratio of the point X at Figure in Note (6).

Note (3) Definition of Response Time ( $T_R$ ,  $T_F$ ):

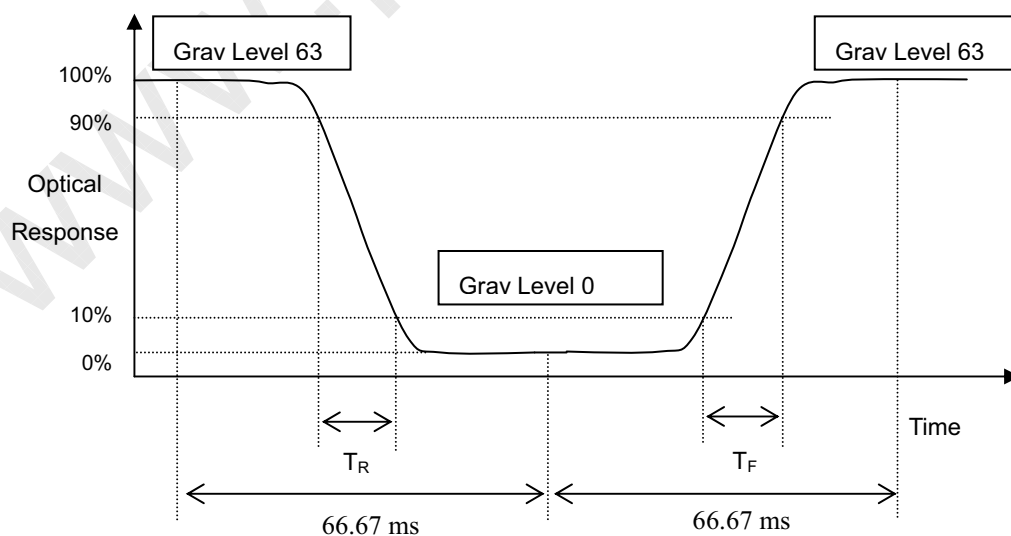

Note (4) Definition of Average Luminance of White ( $L_{AVE}$ ):

Measure the luminance of gray level 63 at 5 points

$$L_{AVE} = [L(1) + L(2) + L(3) + L(4) + L(5)] / 5$$

$L(x)$  is corresponding to the luminance of the point X at Figure in Note (6)

Note (5) Measurement Setup:

The LCD module should be stabilized at given temperature for 20 minutes to avoid abrupt temperature change during measuring. In order to stabilize the luminance, the measurement should be executed after lighting Backlight for 20 minutes in a windless room.

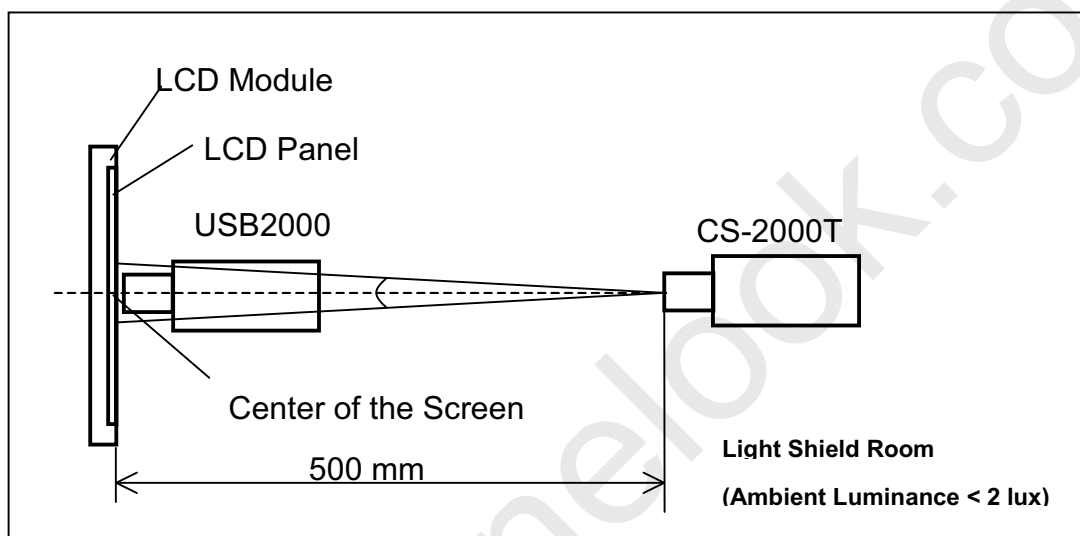

Note (6) Definition of White Variation ( $\delta W$ ):

Measure the luminance of gray level 63 at 5 points

$$\delta W_{5p} = \{ \text{Minimum} [L(1) \sim L(5)] / \text{Maximum} [L(1) \sim L(5)] \} * 100\%$$

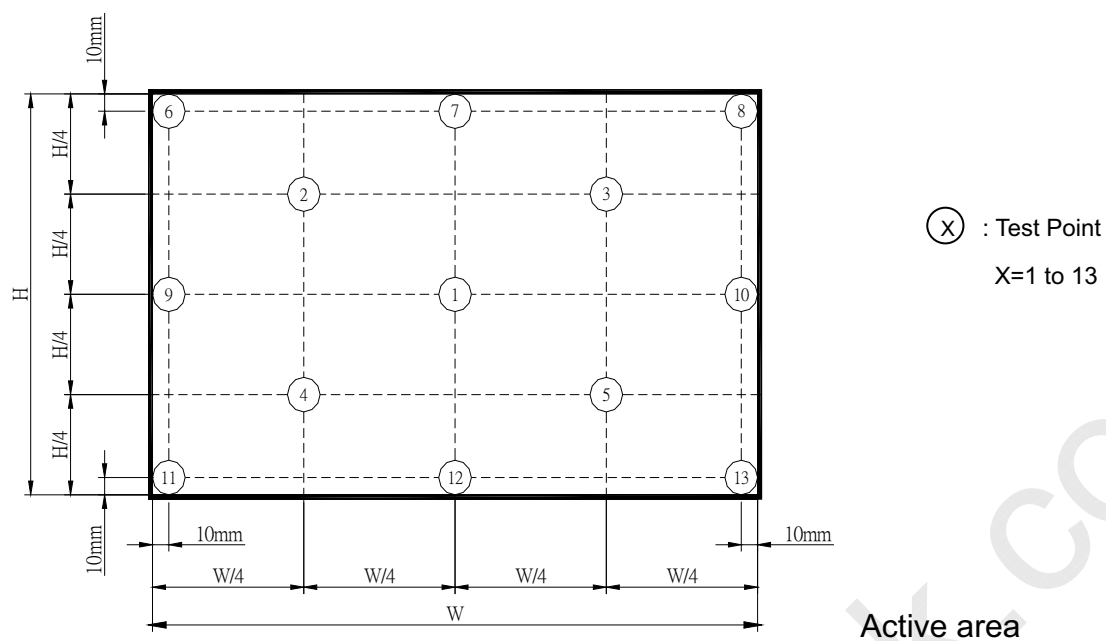

Note (7) The listed optical specifications refer to the initial value of manufacture, but the condition of the specifications after long-term operation will not be warranted.

## 8. PRECAUTIONS

### 8.1 HANDLING PRECAUTIONS

- (1) The module should be assembled into the system firmly by using every mounting hole. Be careful not to twist or bend the module.
- (2) While assembling or installing modules, it can only be in the clean area. The dust and oil may cause electrical short or damage the polarizer.
- (3) Use fingerstalls or soft gloves in order to keep display clean during the incoming inspection and assembly process.
- (4) Do not press or scratch the surface harder than a HB pencil lead on the panel because the polarizer is very soft and easily scratched.
- (5) If the surface of the polarizer is dirty, please clean it by some absorbent cotton or soft cloth. Do not use Ketone type materials (ex. Acetone), Ethyl alcohol, Toluene, Ethyl acid or Methyl chloride. It might permanently damage the polarizer due to chemical reaction.
- (6) Wipe off water droplets or oil immediately. Staining and discoloration may occur if they left on panel for a long time.
- (7) If the liquid crystal material leaks from the panel, it should be kept away from the eyes or mouth. In case of contacting with hands, legs or clothes, it must be washed away thoroughly with soap.
- (8) Protect the module from static electricity, it may cause damage to the C-MOS Gate Array IC.
- (9) Do not disassemble the module.
- (10) Do not pull or fold the LED wire.
- (11) Pins of I/F connector should not be touched directly with bare hands.

### 8.2 STORAGE PRECAUTIONS

- (1) High temperature or humidity may reduce the performance of module. Please store LCD module within the specified storage conditions.
- (2) It is dangerous that moisture come into or contacted the LCD module, because the moisture may damage LCD module when it is operating.
- (3) It may reduce the display quality if the ambient temperature is lower than 10 °C. For example, the response time will become slowly, and the starting voltage of LED will be higher than the room temperature.

### 8.3 OPERATION PRECAUTIONS

- (1) Do not pull the I/F connector in or out while the module is operating.
- (2) Always follow the correct power on/off sequence when LCD module is connecting and operating. This can prevent the CMOS LSI chips from damage during latch-up.
- (3) The startup voltage of Backlight is approximately 1000 Volts. It may cause electrical shock while assembling with converter. Do not disassemble the module or insert anything into the Backlight unit.



## 9. PACKING

### 9.1 CARTON

(1) Box Dimensions : 442(L)\*392(W)\*300(H)

(2) 20 modules/Carton

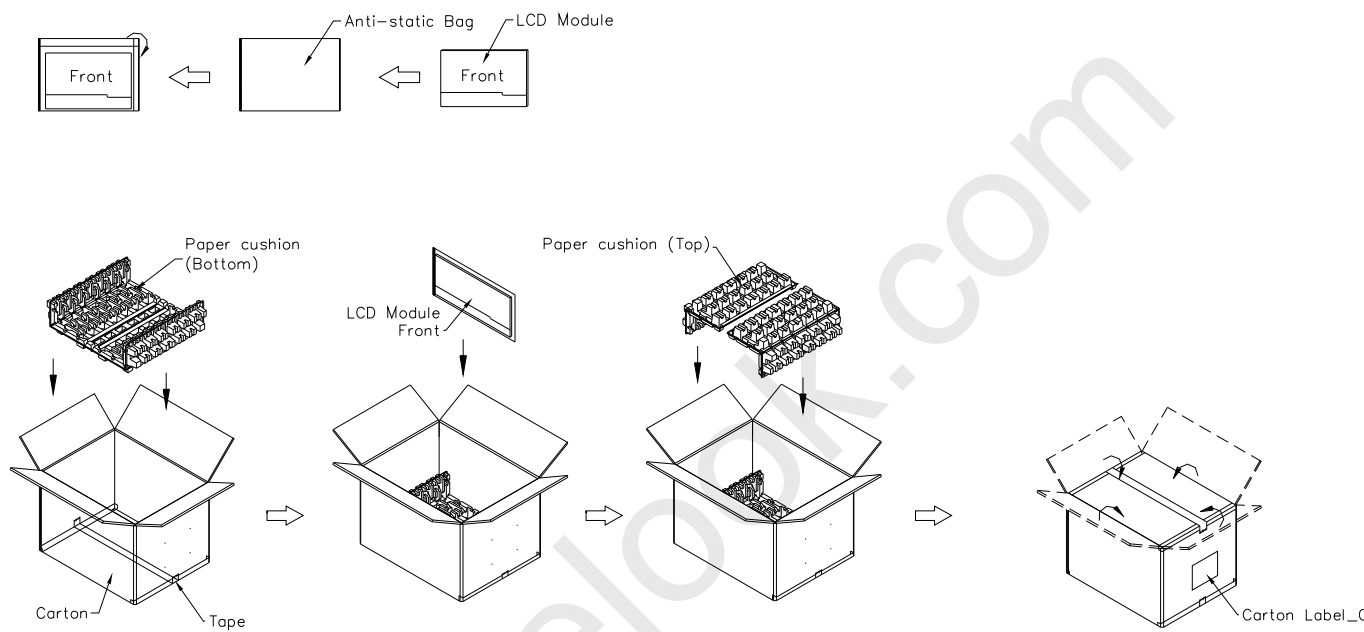

Figure. 9-1 Packing method

## 9.2 PALLET

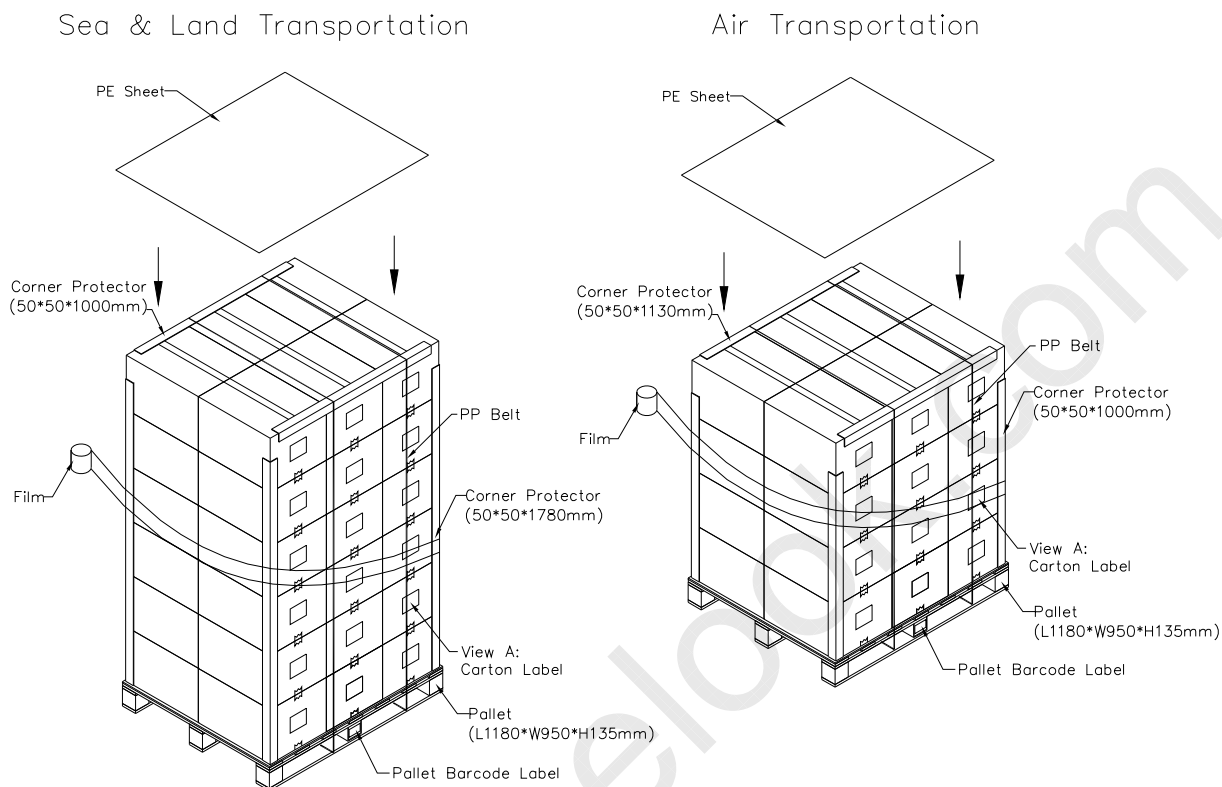
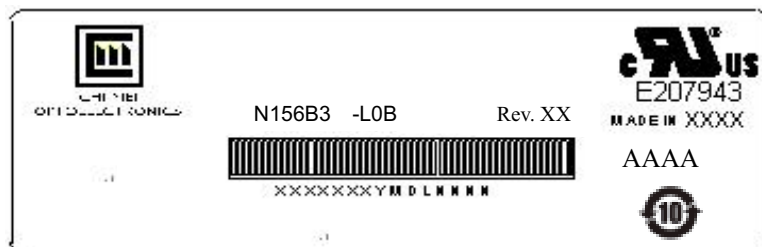

Figure. 9-2 Packing method

## 10. DEFINITION OF LABELS

### 10.1 CMO MODULE LABEL

The barcode nameplate is pasted on each module as illustration, and its definitions are as following explanation.



- (a) Model Name: N156B3 - L0B
- (b) Revision: Rev. XX, for example: C1, C2 ...etc.
- (c) Serial ID: X X X X X X X Y M D L N N N N

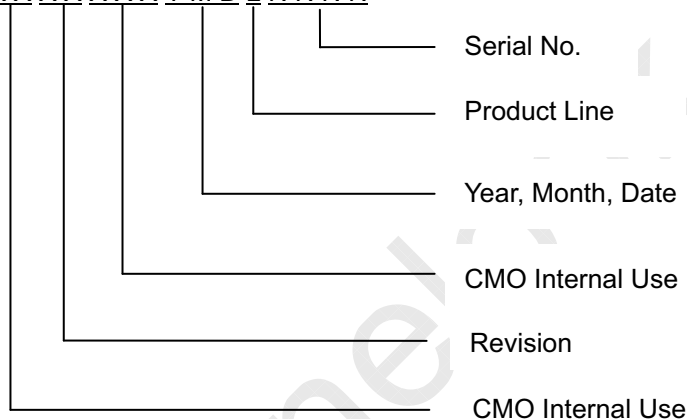

- (d) Production Location: MADE IN XXXX. XXXX stands for production location.
- (e) UL logo: "AAAA" especially stands for panel manufactured by CMO China satisfying UL requirement. "LEOO" and "COCKN" is the CMO's UL factory code for Ningbo factory..

Serial ID includes the information as below:

- (a) Manufactured Date: Year: 1~9, for 2001~2009  
Month: 1~9, A~C, for Jan. ~ Dec.  
Day: 1~9, A~Y, for 1<sup>st</sup> to 31<sup>st</sup>, exclude I , O and U
- (b) Revision Code: cover all the change
- (c) Serial No.: Manufacturing sequence of product
- (d) Product Line: 1 -> Line1, 2 -> Line 2, ...etc.

## 10.2 CARTON LABEL

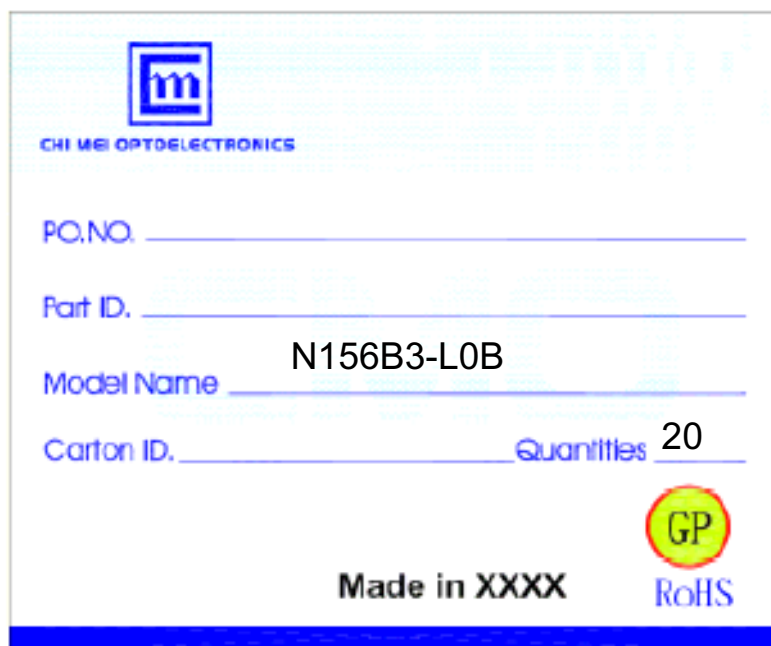

CHI MEI OPTOELECTRONICS

PO.NO. \_\_\_\_\_

Part ID. \_\_\_\_\_

Model Name N156B3-L0B

Carton ID. \_\_\_\_\_ Quantities 20

Made in XXXX

 GP  
RoHS

## Appendix. OUTLINE DRAWING

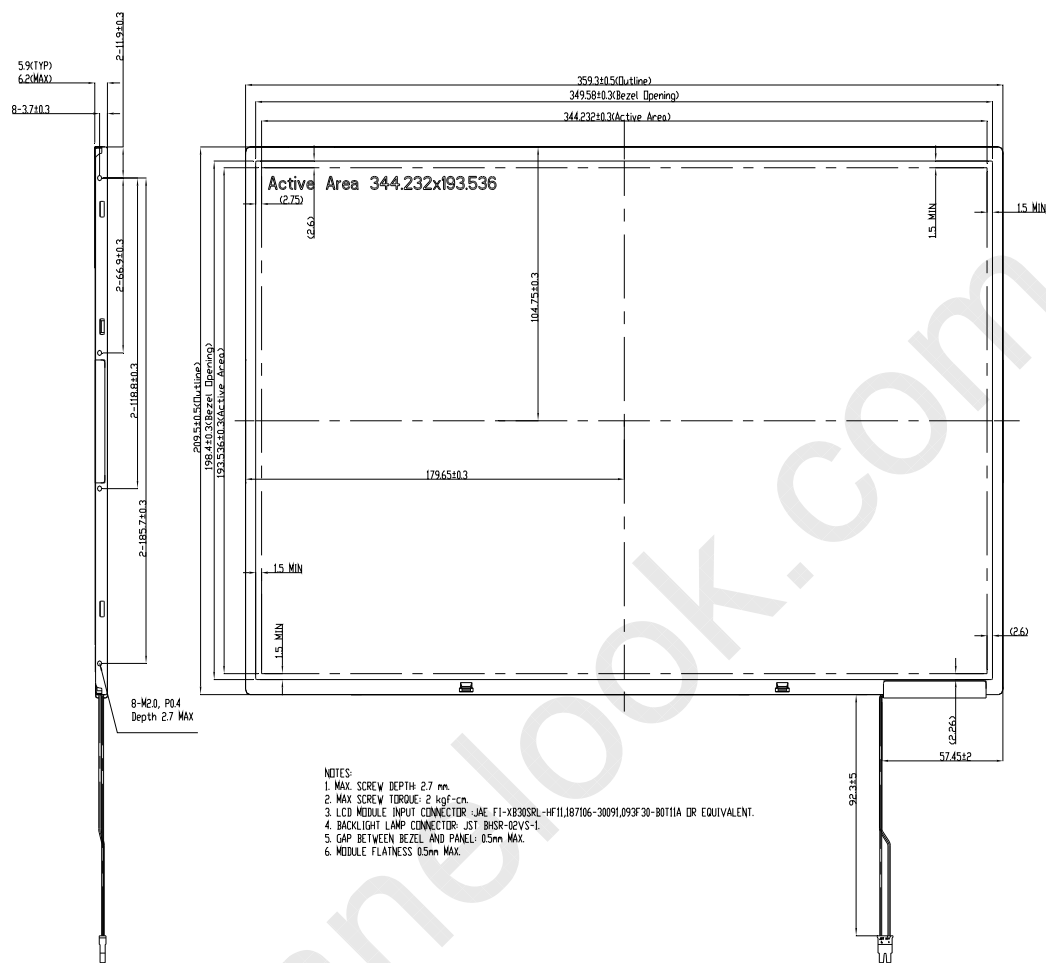

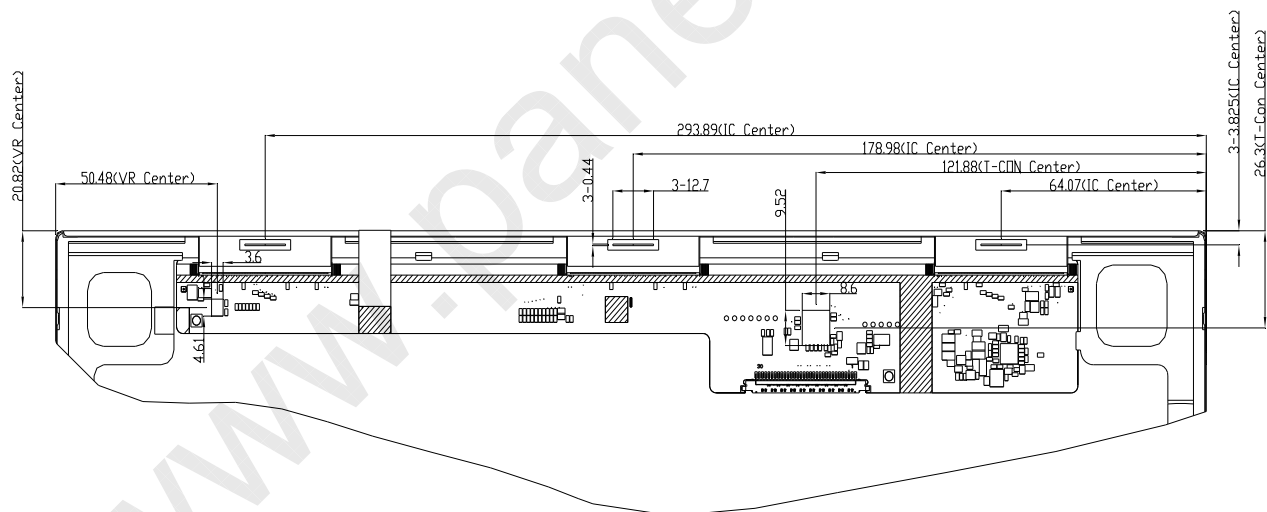
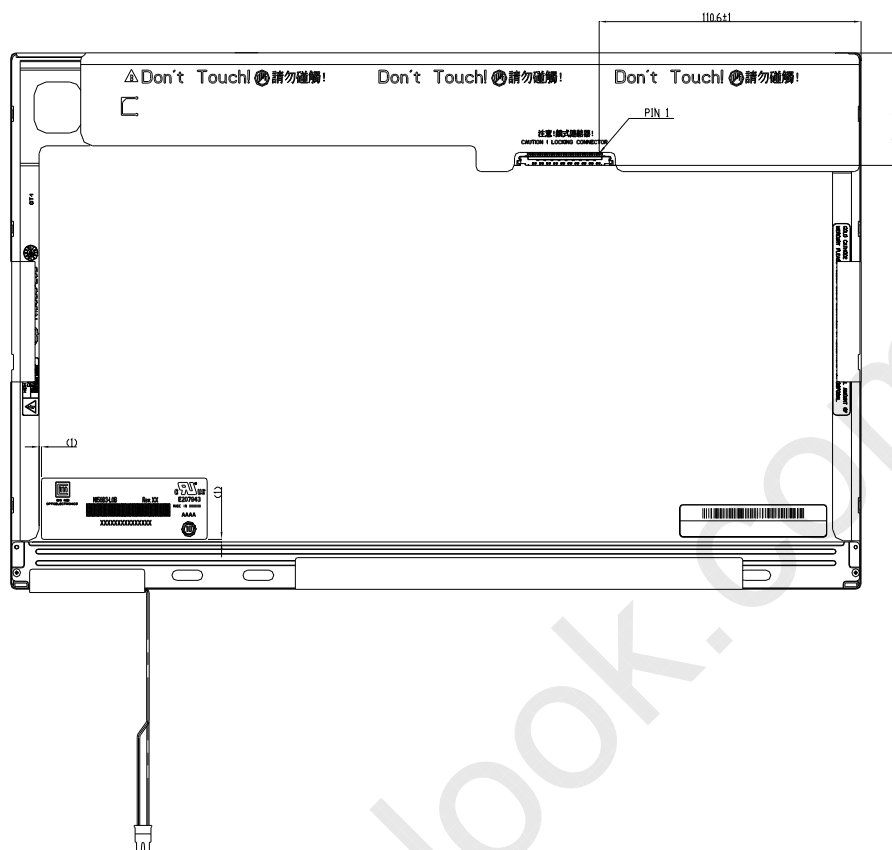

## NOTES:

1. IN ORDER TO AVOID ABNORMAL DISPLAY, POOLING AND WHITE SPOT, NO OVERLAPPING IS SUGGESTED AT CABLES, ANTENNAS, CAMERA, WLAN, WAM OR OTHER FOREIGN OBJECTS OVER TCN AND VR LOCATION.