

TFT LCD Approval Specification

MODEL NO.: N156B6-L07

Customer : <u>Lenovo International</u>
Approved by : _____
Note : Quanta

核准時間	部門	審核	角色	投票
2009-09-30 08:47:48	NB 產品管理處		Director (deputy)	Accept

- CONTENTS -

REVISION HISTORY	-----	3
1. GENERAL DESCRIPTION	-----	4
1.1 OVERVIEW		
1.2 FEATURES		
1.3 APPLICATION		
1.4 GENERAL SPECIFICATIONS		
1.5 MECHANICAL SPECIFICATIONS		
2. ABSOLUTE MAXIMUM RATINGS	-----	5
2.1 ABSOLUTE RATINGS OF ENVIRONMENT		
2.2 ELECTRICAL ABSOLUTE RATINGS		
3. ELECTRICAL CHARACTERISTICS	-----	7
3.1 TFT LCD MODULE		
3.2 BACKLIGHT UNIT		
4. BLOCK DIAGRAM	-----	10
4.1 TFT LCD MODULE		
4.2 BACKLIGHT UNIT		
5. INPUT TERMINAL PIN ASSIGNMENT	-----	11
5.1 TFT LCD MODULE		
5.2 TIMING DIAGRAM OF LVDS INPUT SIGNAL		
5.3 COLOR DATA INPUT ASSIGNMENT		
5.4 EDID DATA STRUCTURE		
6. CONVERTER	-----	17
6.1 ABSOLUTE MAXIMUM RATINGS		
6.2 RECOMMENDED OPERATING RATINGS		
7. INTERFACE TIMING	-----	19
7.1 INPUT SIGNAL TIMING SPECIFICATIONS		
7.2 POWER ON/OFF SEQUENCE		
8. OPTICAL CHARACTERISTICS	-----	22
8.1 TEST CONDITIONS		
8.2 OPTICAL SPECIFICATIONS		
9. PRECAUTIONS	-----	26
9.1 HANDLING PRECAUTIONS		
9.2 STORAGE PRECAUTIONS		
9.3 OPERATION PRECAUTIONS		
10. PACKING	-----	27
10.1 CARTON		
10.2 PALLET		
11. DEFINITION OF LABELS	-----	29
11.1 CMO MODULE LABEL		
11.2 CARTON LABEL		
12. INSPECTION STANDARDS FOR LCD MOUDULES	-----	31

REVISION HISTORY

Version	Date	Page (New)	Section	Description
Ver 3.0	May,22' 2009	All	All	Approval spec 3.0 was first issued for N156B6-L07 for Lenovo JP
Ver 3.1	Jun,22'2009	14	5.4	EDID DATA STRUCTURE
Ver 3.2	Sep, 10,2009	37	Drawing	Update the outline drawing with FPC Mylar tape attachment

1. GENERAL DESCRIPTION

1.1 OVERVIEW

N156B6-L07 is a 15.6" (15.547" diagonal) TFT Liquid Crystal Display module with LED Backlight unit and 40 pins LVDS interface. This module supports 1366 x 768 HD mode and can display 262,144 colors. The optimum viewing angle is at 6 o'clock direction.

1.2 FEATURES

- HD (1366 x 768 pixels) resolution
- 3.3V LVDS (Low Voltage Differential Signaling) interface with 1 pixel/clock
- WLED

1.3 APPLICATION

- TFT LCD Notebook

1.4 GENERAL SPECIFICATIONS

Item	Specification	Unit	Note
Active Area	344.232 (H) x 193.536 (V) (15.547" diagonal)	mm	(1)
Bezel Opening Area	348.43 (H) x 197.74 (V)	mm	
Driver Element	a-si TFT active matrix	-	-
Pixel Number	1366 x R.G.B. x 768	pixel	-
Pixel Pitch	0.252 (H) x 0.252 (V)	mm	-
Pixel Arrangement	RGB vertical stripe	-	-
Display Colors	262,144	color	-
Transmissive Mode	Normally white	-	-
Surface Treatment	Hard coating (3H), Anti-glare	-	-

1.5 MECHANICAL SPECIFICATIONS

Item	Min.	Typ.	Max.	Unit	Note	
Module Size	Horizontal(H)	358.8	359.3	359.8	mm	(1)
	Vertical(V)	209	209.5	210	mm	
	Thickness(T)	-	5.2	5.5	mm	
Weight	---	430	445	g	-	

Note (1) Please refer to the attached drawings for more information of front and back outline dimensions.

2. ABSOLUTE MAXIMUM RATINGS

2.1 ABSOLUTE RATINGS OF ENVIRONMENT

Item	Symbol	Value		Unit	Note
		Min.	Max.		
Storage Temperature	T _{ST}	-20	+60	°C	(1)
Operating Ambient Temperature	T _{OP}	0	+50	°C	(1), (2)
Shock (Non-Operating)	S _{NOP}	-	220/2	G/ms	(3), (5)
Vibration (Non-Operating)	V _{NOP}	-	1.5	G	(4), (5)

Note (1) (a) 90 %RH Max. (Ta ≤ 40 °C).

(b) Wet-bulb temperature should be 39 °C Max. (Ta > 40 °C).

(c) No condensation.

Note (2) The temperature of panel surface should be 0 °C min. and 60 °C max.

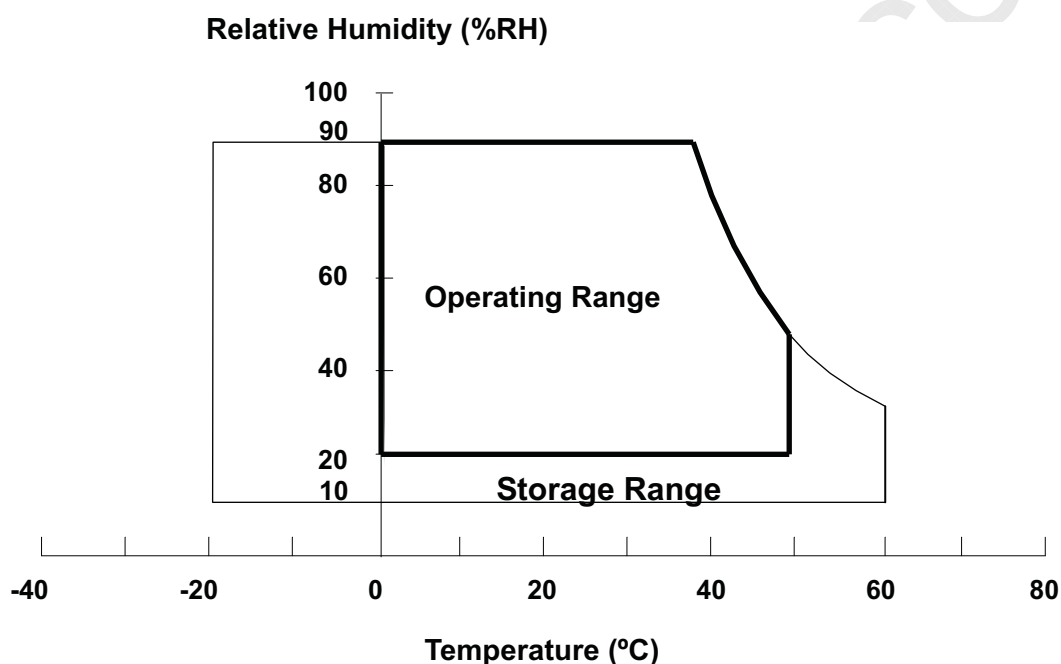

Note (3) 1 time for ± X, ± Y, ± Z. for Condition (220G / 2ms) is half Sine Wave,.

Note (4) 10~500 Hz, 0.5hr/cycle 1cycle for X,Y,Z

Note (5) At testing Vibration and Shock, the fixture in holding the module has to be hard and rigid enough so that the module would not be twisted or bent by the fixture.

The fixing condition is shown as below:

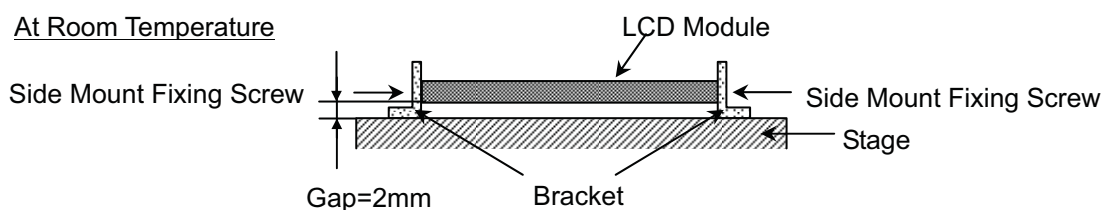

2.2 ELECTRICAL ABSOLUTE RATINGS

2.2.1 TFT LCD MODULE

Item	Symbol	Value		Unit	Note
		Min.	Max.		
Power Supply Voltage	V _{CC}	-0.3	+4.0	V	(1)
Logic Input Voltage	V _{IN}	-0.3	V _{CC} +0.3	V	

2.2.2 BACKLIGHT UNIT

Item	Symbol	Value		Unit	Note
		Min.	Max.		
LED Light Bar Power Supply Voltage	V _L	-40	28	V	(1), (2)
LED Light Bar Power Supply Current	I _L	0	150	mA	

Note (1) Permanent damage to the device may occur if maximum values are exceeded. Function operation should be restricted to the conditions described under Normal Operating Conditions.

Note (2) Specified values are for LED (Refer to 3.2 for further information).

3. ELECTRICAL CHARACTERISTICS

3.1 TFT LCD MODULE

Ta = 25 ± 2 °C

Parameter	Symbol	Value			Unit	Note
		Min.	Typ.	Max.		
Power Supply Voltage	V _{CC}	3.0	3.3	3.6	V	-
Ripple Voltage	V _{RP}	-	50		mV	-
Rush Current	I _{RUSH}	-	-	1.5	A	(2)
Initial Stage Current	I _{IS}	-	-	1.0	A	(2)
Power Supply Current	White	240	260	280	mA	(3)a
	Black	350	380	400	mA	(3)b
LVDS Differential Input High Threshold	V _{TH(LVDS)}	-	-	+100	mV	(5), V _{CM} =1.2V
LVDS Differential Input Low Threshold	V _{TL(LVDS)}	-100	-	-	mV	(5), V _{CM} =1.2V
LVDS Common Mode Voltage	V _{CM}	1.125	-	1.375	V	(5)
LVDS Differential Input Voltage	V _{ID}	100	-	600	mV	(5)
Terminating Resistor	R _T	-	100	-	Ohm	-
Power per EBL WG	P _{EBL}	-	1.92	-	W	(4)

Note (1) The ambient temperature is Ta = 25 ± 2 °C.

Note (2) I_{RUSH}: the maximum current when VCC is rising

I_{IS}: the maximum current of the first 100ms after power-on

Measurement Conditions: Shown as the following figure. Test pattern: black.

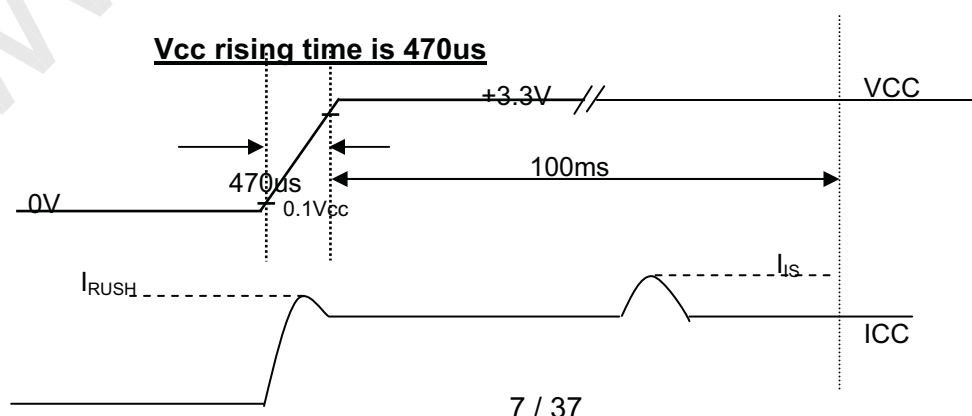
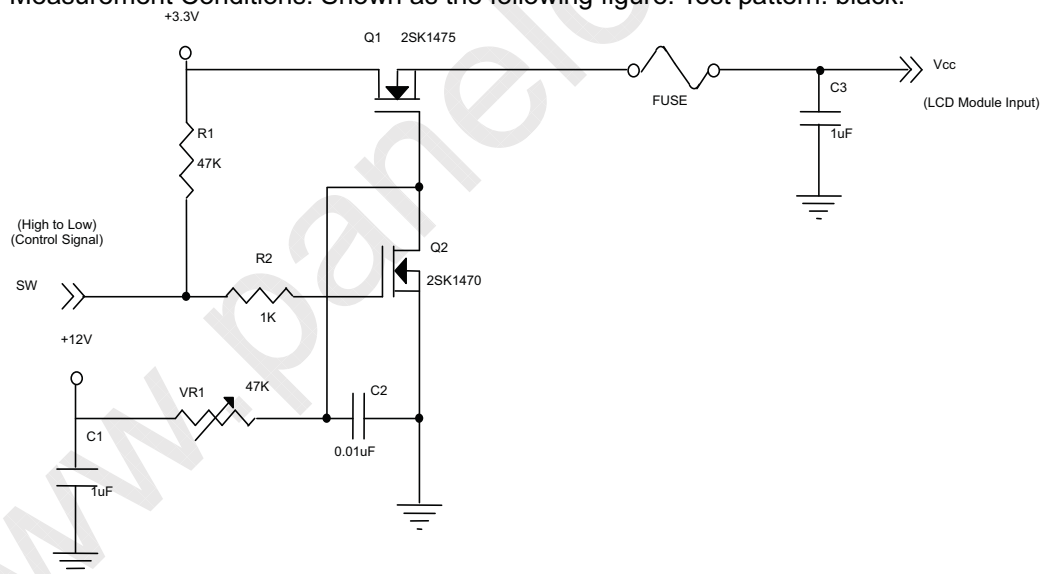

Note (3) The specified power supply current is under the conditions at $V_{CC} = 3.3\text{ V}$, $T_a = 25 \pm 2\text{ }^\circ\text{C}$, DC Current and $f_v = 60\text{ Hz}$, whereas a power dissipation check pattern below is displayed.

a. White Pattern



Active Area

b. Black Pattern

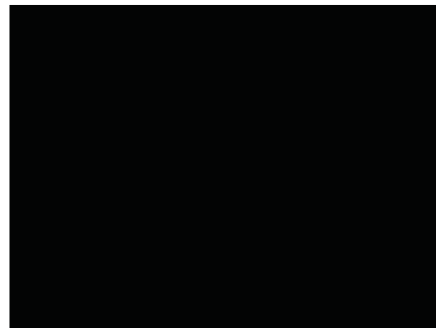

Active Area

Note (4) The specified power are the sum of LCD panel electronics input power and the converter input power. Test conditions are as follows.

- $V_{CC} = 3.3\text{ V}$, $T_a = 25 \pm 2\text{ }^\circ\text{C}$, $f_v = 60\text{ Hz}$,
- The pattern used is a black and white 32 x 36 checkerboard, slide #100 from the VESA file "Flat Panel Display Monitor Setup Patterns", FPDMSU.ppt.
- Luminance: 60 nits.

Note (5) The parameters of LVDS signals are defined as the following figures.

Single Ended

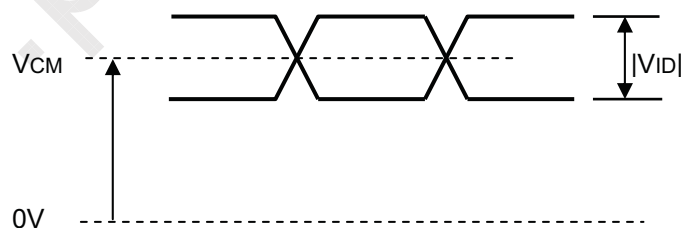

Differential

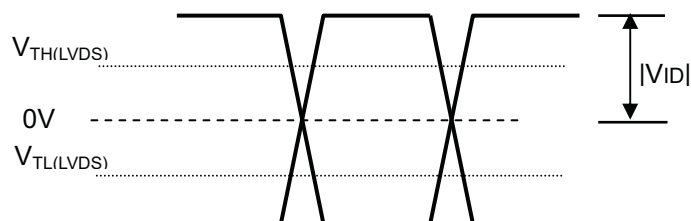

3.2 BACKLIGHT UNIT

Ta = 25 ± 2 °C

Parameter	Symbol	Value			Unit	Note
		Min.	Typ.	Max.		
LED Light Bar Power Supply Voltage	V _L	23.2	25.6	28	V	(1),(2) (Duty 100%)
LED Light Bar Power Supply Current	I _L	114	120	126	mA	
Power Consumption	P _L	2.65	3.07	3.53	W	(3), (Duty 100%)
LED Life Time	L _{BL}	15000	-	-	Hrs	(4)

Note (1) LED light bar configuration is shown as below.

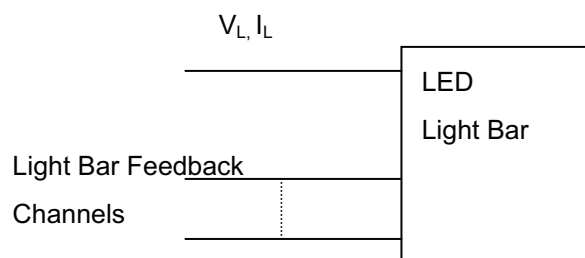

Note (2) For better LED light bar driving quality, it is recommended to utilize the adaptive boost converter with current balancing function to drive LED light-bar.

Note (3) $P_L = I_L \times V_L$

Note (4) LED Lifetime was defined as the time when it continues to operate under the conditions at Ta=25±2 °C and I_L = 20 mA(Per EA) until the brightness becomes ≤ 50% of its original value.

4. BLOCK DIAGRAM

4.1 TFT LCD MODULE

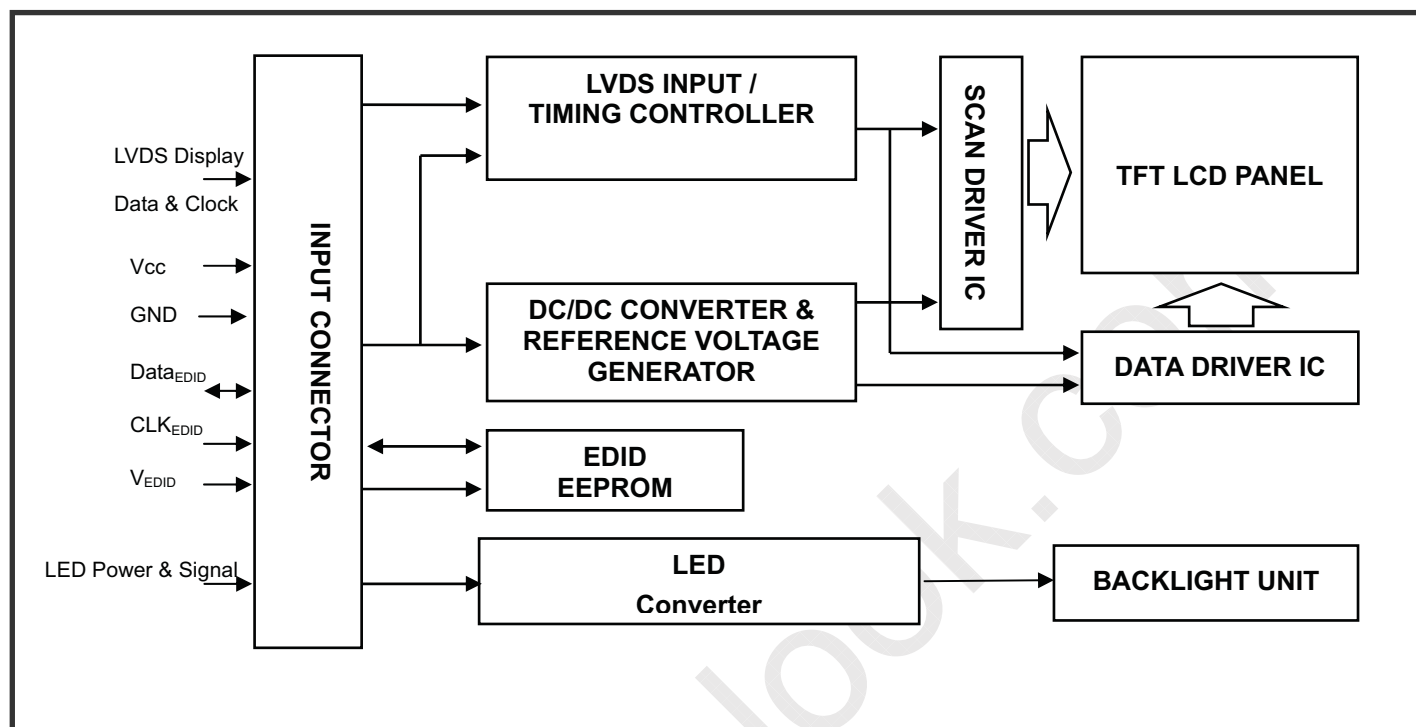

5. INPUT TERMINAL PIN ASSIGNMENT

5.1 TFT LCD MODULE

Pin	Symbol	Description	Polarity	Remark
1	Reserve	Non-Connection use by CMO		
2	Vcc	Power Supply +3.3 V (typical)		
3	Vcc	Power Supply +3.3 V (typical)		
4	V _{EDID}	DDC 3.3V Power		DDC 3.3V Power
5	Reserve	Non-Connection use by CMO		
6	CLK _{EDID}	DDC Clock		DDC Clock
7	DATA _{EDID}	DDC Data		DDC Data
8	Rxin0-	LVDS Differential Data Input	Negative	R0~R5,G0
9	Rxin0+	LVDS Differential Data Input	Positive	
10	Vss	Ground		G1~G5, B0, B1
11	Rxin1-	LVDS Differential Data Input	Negative	
12	Rxin1+	LVDS Differential Data Input	Positive	
13	Vss	Ground		B2~B5, DE, Hsync, Vsync
14	Rxin2-	LVDS Differential Data Input	Negative	
15	Rxin2+	LVDS Differential Data Input	Positive	
16	Vss	Ground		LVDS Level Clock
17	CLK-	LVDS Clock Data Input	Negative	
18	CLK+	LVDS Clock Data Input	Positive	
19	Vss	Ground		
20	NC	Non-Connection		
21	NC	Non-Connection		
22	Vss	Ground		
23	NC	Non-Connection		
24	NC	Non-Connection		
25	Vss	Ground		
26	NC	Non-Connection		
27	NC	Non-Connection		
28	Vss	Ground		
29	NC	Non-Connection		
30	NC	Non-Connection		
31	LED_GND	Ground_LED		
32	LED_GND	Ground_LED		
33	LED_GND	Ground_LED		
34	Reserve	Non-Connection use by CMO		
35	LED_PWM	System PWM Signal Input		
36	LED_EN	LED enable pin		
37	Reserve	Non-Connection use by CMO		
38	LED_VCCS	LED Power		
39	LED_VCCS	LED Power		
40	LED_VCCS	LED Power		

Note (1) Connector Part No. I-PEX 20455-040E-12

Note (2) User's connector Part No: I-PEX 20453-040T or equivalent

Note (3) The first pixel is odd as shown in the following figure.

5.2 TIMING DIAGRAM OF LVDS INPUT SIGNAL

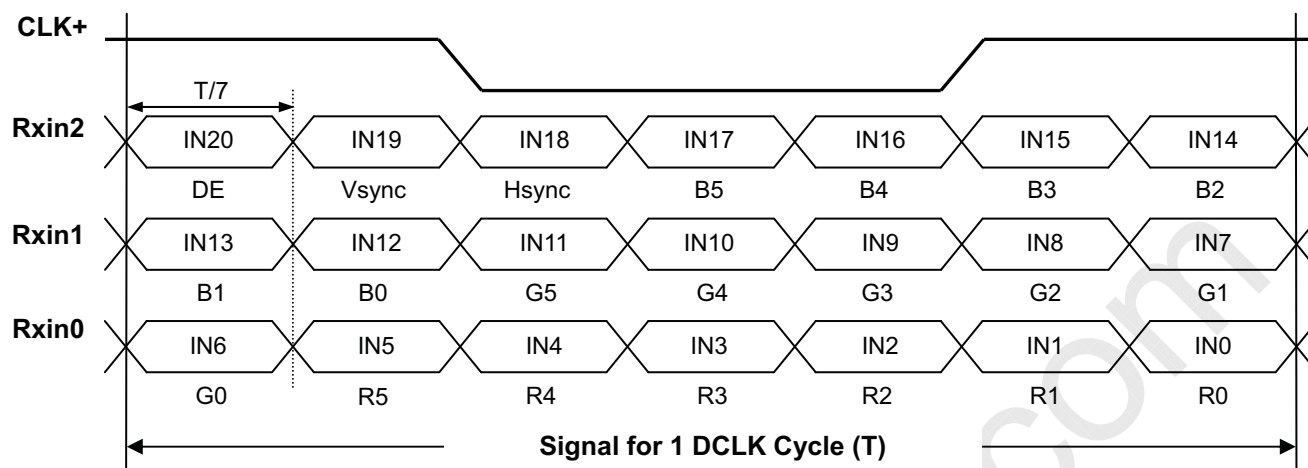



5.3 COLOR DATA INPUT ASSIGNMENT

The brightness of each primary color (red, green and blue) is based on the 6-bit gray scale data input for the color. The higher the binary input the brighter the color. The table below provides the assignment of color versus data input.

Color		Data Signal																	
		Red						Green						Blue					
		R5	R4	R3	R2	R1	R0	G5	G4	G3	G2	G1	G0	B5	B4	B3	B2	B1	B0
Basic Colors	Black	0	0	0	0	0	0	0	0	0	0	0	0	0	0	0	0	0	0
	Red	1	1	1	1	1	1	0	0	0	0	0	0	0	0	0	0	0	0
	Green	0	0	0	0	0	0	1	1	1	1	1	1	0	0	0	0	0	0
	Blue	0	0	0	0	0	0	0	0	0	0	0	0	1	1	1	1	1	1
	Cyan	0	0	0	0	0	0	1	1	1	1	1	1	1	1	1	1	1	1
	Magenta	1	1	1	1	1	1	0	0	0	0	0	0	1	1	1	1	1	1
	Yellow	1	1	1	1	1	1	1	1	1	1	1	1	0	0	0	0	0	0
	White	1	1	1	1	1	1	1	1	1	1	1	1	1	1	1	1	1	1
Gray Scale Of Red	Red(0)/Dark	0	0	0	0	0	0	0	0	0	0	0	0	0	0	0	0	0	0
	Red(1)	0	0	0	0	0	1	0	0	0	0	0	0	0	0	0	0	0	0
	Red(2)	0	0	0	0	1	0	0	0	0	0	0	0	0	0	0	0	0	0
	:	:	:	:	:	:	:	:	:	:	:	:	:	:	:	:	:	:	:
	:	:	:	:	:	:	:	:	:	:	:	:	:	:	:	:	:	:	:
	:	:	:	:	:	:	:	:	:	:	:	:	:	:	:	:	:	:	:
	Red(61)	1	1	1	1	0	1	0	0	0	0	0	0	0	0	0	0	0	0
	Red(62)	1	1	1	1	1	0	0	0	0	0	0	0	0	0	0	0	0	0
Red(63)	1	1	1	1	1	1	0	0	0	0	0	0	0	0	0	0	0	0	
Gray Scale Of Green	Green(0)/Dark	0	0	0	0	0	0	0	0	0	0	0	0	0	0	0	0	0	0
	Green(1)	0	0	0	0	0	0	0	0	0	0	0	1	0	0	0	0	0	0
	Green(2)	0	0	0	0	0	0	0	0	0	0	1	0	0	0	0	0	0	0
	:	:	:	:	:	:	:	:	:	:	:	:	:	:	:	:	:	:	:
	:	:	:	:	:	:	:	:	:	:	:	:	:	:	:	:	:	:	:
	:	:	:	:	:	:	:	:	:	:	:	:	:	:	:	:	:	:	:
	Green(61)	0	0	0	0	0	0	1	1	1	1	0	1	0	0	0	0	0	0
	Green(62)	0	0	0	0	0	0	1	1	1	1	1	0	0	0	0	0	0	0
Green(63)	0	0	0	0	0	0	1	1	1	1	1	1	0	0	0	0	0	0	
Gray Scale Of Blue	Blue(0)/Dark	0	0	0	0	0	0	0	0	0	0	0	0	0	0	0	0	0	0
	Blue(1)	0	0	0	0	0	0	0	0	0	0	0	0	0	0	0	0	0	1
	Blue(2)	0	0	0	0	0	0	0	0	0	0	0	0	0	0	0	0	1	0
	:	:	:	:	:	:	:	:	:	:	:	:	:	:	:	:	:	:	:
	:	:	:	:	:	:	:	:	:	:	:	:	:	:	:	:	:	:	:
	:	:	:	:	:	:	:	:	:	:	:	:	:	:	:	:	:	:	:
	Blue(61)	0	0	0	0	0	0	0	0	0	0	0	0	1	1	1	1	0	1
	Blue(62)	0	0	0	0	0	0	0	0	0	0	0	0	1	1	1	1	1	0
Blue(63)	0	0	0	0	0	0	0	0	0	0	0	0	1	1	1	1	1	1	

Note (1) 0: Low Level Voltage, 1: High Level Voltage

5.4 EDID DATA STRUCTURE

The EDID (Extended Display Identification Data) data formats are to support displays as defined in the

Byte # (decimal)	Byte # (hex)	Field Name and Comments	Value (hex)	Value (binary)
0	0	Header	00	00000000
1	1	Header	FF	11111111
2	2	Header	FF	11111111
3	3	Header	FF	11111111
4	4	Header	FF	11111111
5	5	Header	FF	11111111
6	6	Header	FF	11111111
7	7	Header	00	00000000
8	8	ID system manufacturer name (LSB)	30	00110000
9	9	ID system manufacturer name (MSB)	AE	10101110
10	0A	ID system Product Code (LSB)	B0	10110000
11	0B	ID system Product Code (MSB)	40	01000000
12	0C	ID Serial Number (32-bit serial number)	00	00000000
13	0D	ID Serial Number (32-bit serial number)	00	00000000
14	0E	ID Serial Number (32-bit serial number)	00	00000000
15	0F	ID Serial Number (32-bit serial number)	00	00000000
16	10	Week of Manufacture	0A	00001010
17	11	Year of Manufacture	13	00010011
18	12	EDID Structure version	01	00000001
19	13	EDID Revision	03	00000011
20	14	Video Input Definition	80	10000000
21	15	Active Area Horizontal Image Size (cm) - 35 cm	23	00100011
22	16	Active Area Vertical Image Size (cm) - 19cm	13	00010011
23	17	Display gamma (gamma x 100)-100, (Gamma 2.2)	78	01111000
24	18	Feature support	EA	11101010
25	19	Rx1, Rx0, Ry1, Ry0, Gx1, Gx0, Gy1, Gy0	7B	01111011
26	1A	Bx1, Bx0, By1, By0, Wx1, Wx0, Wy1, Wy0	95	10010101
27	1B	Rx=0.61	9C	10011100
28	1C	Ry=0.343	57	01010111
29	1D	Gx=0.342	57	01010111
30	1E	Gy=0.581	94	10010100
31	1F	Bx=0.162	29	00101001
32	20	By=0.083	15	00010101
33	21	Wx=0.313	50	01010000
34	22	Wy=0.329	54	01010100
35	23	Established Timing 1	00	00000000
36	24	Established Timing 2	00	00000000
37	25	Manufacturer's Timings	00	00000000
38	26	Standard Timing Identification #1	01	00000001
39	27	Standard Timing Identification #1	01	00000001

40	28	Standard Timing Identification #2	01	00000001
41	29	Standard Timing Identification #2	01	00000001
42	2A	Standard Timing Identification #3	01	00000001
43	2B	Standard Timing Identification #3	01	00000001
44	2C	Standard Timing Identification #4	01	00000001
45	2D	Standard Timing Identification #4	01	00000001
46	2E	Standard Timing Identification #5	01	00000001
47	2F	Standard Timing Identification #5	01	00000001
48	30	Standard Timing Identification #6	01	00000001
49	31	Standard Timing Identification #6	01	00000001
50	32	Standard Timing Identification #7	01	00000001
51	33	Standard Timing Identification #7	01	00000001
52	34	Standard Timing Identification #8	01	00000001
53	35	Standard Timing Identification #8	01	00000001
54	36	Detailed timing description # 1 Pixel clock ("71.93MHz", According to VESA CVT Rev1.1)	19	00011001
55	37	# 1 Pixel clock (hex LSB first)	1C	00011100
56	38	# 1 H active ("1366")	56	01010110
57	39	# 1 H blank ("142")	8E	10001110
58	3A	# 1 H active : H blank ("1366 :142")	50	01010000
59	3B	# 1 V active ("768")	00	00000000
60	3C	# 1 V blank ("27")	1B	00011011
61	3D	# 1 V active : V blank ("768 :27")	30	00110000
62	3E	# 1 H sync offset ("23")	17	00010111
63	3F	# 1 H sync pulse width ("48")	30	00110000
64	40	# 1 V sync offset : V sync pulse width ("3:9")	39	00111001
65	41	# 1 H sync offset : H sync pulse width : V sync offset : V sync width ("23 : 48 : 3 : 9")	00	00000000
66	42	# 1 H image size ("344 mm")	58	01011000
67	43	# 1 V image size ("193 mm")	C1	11000001
68	44	# 1 H image size : V image size ("344 : 193")	10	00010000
69	45	# 1 H boarder ("0")	00	00000000
70	46	# 1 V boarder ("0")	00	00000000
71	47	# 1 Non-interlaced, Normal, no stereo, Separate sync, H/V pol Negatives	18	00011000
72	48	Detailed timing description # 2 Pixel clock ("58.49MHz", According to VESA CVT Rev1.1)	D9	11011001
73	49	#2 Pixel clock (hex LSB first)	16	00010110
74	4A	#2 H active ("1366")	56	01010110
75	4B	# 2 H blank ("128")	80	10000000
76	4C	# 2 H active : H blank ("1366 : 128")	50	01010000
77	4D	# 2 V active ("768")	00	00000000
78	4E	# 2 V blank ("15")	0F	00001111
79	4F	# 2 V active : V blank ("768:15")	30	00110000
80	50	# 2 H sync offset ("38")	26	00100110
81	51	# 2 H sync pulse width ("26")	1A	00011010
82	52	# 2 V sync offset : V sync pulse width ("2 : 4")	24	00100100
83	53	# 2 H sync offset : H sync pulse width : V sync offset : V sync width ("38: 26 : 2 : 4")	00	00000000
84	54	# 2H image size ("344 mm")	58	01011000

85	55	# 2V image size ("193 mm")	C1	11000001
86	56	# 2 H image size : V image size ("344 : 193")	10	00010000
87	57	# 2 H boarder ("0")	00	00000000
88	58	# 2 V boarder ("0")	00	00000000
89	59	# 2 Non-interlaced ; Normal display, no stereo ; Digital Separate ; V sync POL is negative ; H sync POL is positive	18	00011000
90	5A	Flag	00	00000000
91	5B	Flag	00	00000000
92	5C	Flag	00	00000000
93	5D	Data Type Tag	0F	00001111
94	5E	Flag	00	00000000
95	5F	Middle Refresh Rate #1 (Horizontal active pixels / 8) - 31	8C	10001100
96	60	Middle Refresh Rate #1 Image Aspect ratio (16 : 9)	09	00001001
97	61	Middle Refresh Rate #1 Refresh Rate = 50Hz	32	00110010
98	62	Low Refresh Rate #2 (Horizontal active pixels / 8) - 31	8C	10001100
99	63	Low Refresh Rate #2 Image Aspect ratio(16 : 9)	09	00001001
100	64	Low Refresh Rate #2 Refresh Rate=40Hz	28	00101000
101	65	Brightness(220 /10 nit)	16	00010110
102	66	Feature flag	09	00001001
103	67	Reserved	00	00000000
104	68	LCD Supplier manufacturer code	0D	00001101
105	69	LCD Supplier manufacturer code, (Hex, LSB first)	AF	10101111
106	6A	LCD Supplier Product code	50	01010000
107	6B	LCD Supplier Product code (Hex, LSB first)	14	00010100
108	6C	Flag	00	00000000
109	6D	Flag	00	00000000
110	6E	Flag	00	00000000
111	6F	Data Type Tag	FE	11111110
112	70	Flag	00	00000000
113	71	Model Name (N156B6-L07, 1st character, "N")	4E	01001110
114	72	Model Name (N156B6-L07, 2nd character, "1")	31	00110001
115	73	Model Name (N156B6-L07, 3rd character, "5")	35	00110101
116	74	Model Name (N156B6-L07, 4th character, "6")	36	00110110
117	75	Model Name (N156B6-L07, 5th character, "B")	42	01000010
118	76	Model Name (N156B6-L07, 6th character, "6")	36	00110110
119	77	Model Name (N156B6-L07, 7th character, "-")	2D	00101101
120	78	Model Name (N156B6-L07, 8th character, "L")	4C	01001100
121	79	Model Name (N156B6-L07, 9th character, "0")	30	00110000
122	7A	Model Name (N156B6-L07, 10th character, "7")	37	00110111
123	7B	Model Name(If <13 char, then terminate with ASCII code 0Ah, set remaining char = 20h)	0A	00001010
124	7C	Model Name (If <13 char, then terminate with ASCII code 0Ah, set remaining char = 20h)	20	00100000
125	7D	Model Name (If <13 char, then terminate with ASCII code 0Ah, set remaining char = 20h)	20	00100000
126	7E	Extension flag	00	00000000
127	7F	Checksum	55	01010101

6. CONVERTER

6.1 ABSOLUTE MAXIMUM RATINGS

Symbol	Ratings
LED_VCCS	-0.3~25V
LED_PWM, LED_EN	-0.3V~5.0V

6.2 RECOMMENDED OPERATING RATINGS

Parameter	Symbol	Value			Unit	Note
		Min.				
Converter Input power supply voltage	LED_Vccs	6.0	12.0	21.0	V	
Converter Rush Current	I _{LED_RUSH}			1.5	A	(2)
Converter Initial Stage Current	I _{LED_IS}			1.5	A	(2)
EN Control Level	Backlight On	2.0	5.0	V	V	
	Backlight Off	0	0.8	V	V	
PWM Control Level	PWM High Level	2	5.0	V	V	
	PWM Low Level	0	0.15	V	V	
PWM Control Duty Ratio		1		100	%	
PWM Control Permissible Ripple Voltage	V _{PWM_pp}			100	mV	
PWM Control Frequency	f _{PWM}	100	210	1000	Hz	
Converter Input Current	LED_VCCS=Min	602	714	mA	(1)	(1)
	LED_VCCS=Typ	301	357	mA	(1)	(1)
	LED_VCCS=Max	172	204	mA	(1)	(1)

Note (1) The specified LED power supply current is under the conditions at "LED_VCCS = Min, Typ, Max",
 $T_a = 25 \pm 2^\circ\text{C}$, $f_{\text{PWM}} = 200\text{ Hz}$, Duty=100%.

Note (2) I_{LED_RUSH}: the maximum current when LED_VCCS is rising,

I_{LED_IS}: the maximum current of the first 100ms after power-on,

Measurement Conditions: Shown as the following figure. LED_VCCS = Typ, $T_a = 25 \pm 2^\circ\text{C}$, $f_{\text{PWM}} = 200\text{ Hz}$, Duty=100%.

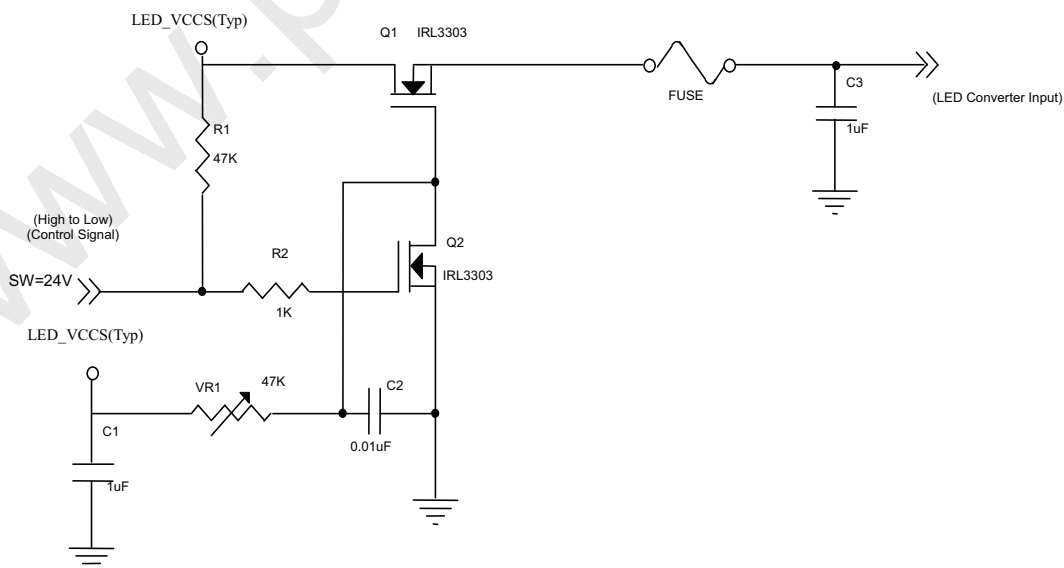

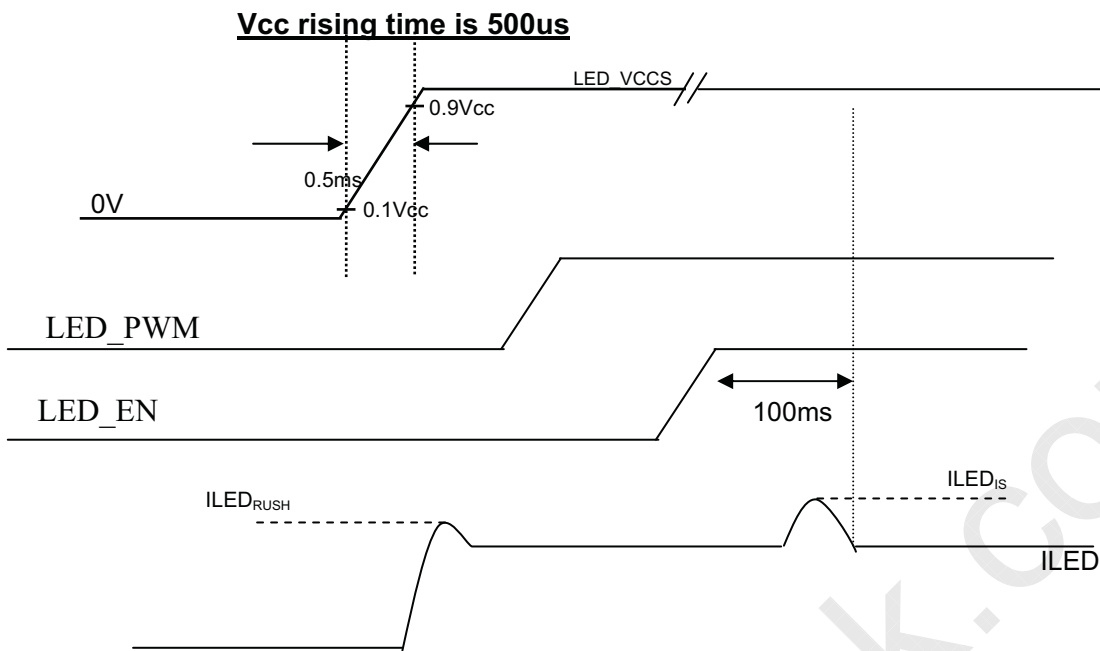

www.panelook.com

7. INTERFACE TIMING

7.1 INPUT SIGNAL TIMING SPECIFICATIONS

The input signal timing specifications are shown as the following table and timing diagram.

Refresh rate 60Hz

Signal	Item	Symbol	Min.	Typ.	Max.	Unit	Note
DCLK	Frequency	1/Tc	67.9	75.5	80	MHz	(2)
DE	Vertical Total Time	TV	778	806	888	TH	-
	Vertical Active Display Period	TVD	768	768	768	TH	-
	Vertical Active Blanking Period	TVB	TV-TVD	38	TV-TVD	TH	
	Horizontal Total Time	TH	1446	1560	1950	Tc	(2)
	Horizontal Active Display Period	THD	1366	1366	1366	Tc	(2)
	Horizontal Active Blanking Period	THB	TH-THD	194	TH-THD	Tc	(2)

Refresh rate 50Hz

Signal	Item	Symbol	Min.	Typ.	Max.	Unit	Note
DCLK	Frequency	1/Tc	52.64	58.49	65.43	MHz	(2)
DE	Vertical Total Time	TV	778	783	862	TH	-
	Vertical Active Display Period	TVD	768	768	768	TH	-
	Vertical Active Blanking Period	TVB	TV-TVD	15	TV-TVD	TH	
	Horizontal Total Time	TH	1446	1494	1867	Tc	(2)
	Horizontal Active Display Period	THD	1366	1366	1366	Tc	(2)
	Horizontal Active Blanking Period	THB	TH-THD	128	TH-THD	Tc	(2)

Refresh rate 40Hz

Signal	Item	Symbol	Min.	Typ.	Max.	Unit	Note
DCLK	Frequency	1/Tc	42.12	46.8	51.48	MHz	(2)
DE	Vertical Total Time	TV	778	783	862	TH	-
	Vertical Active Display Period	TVD	768	768	768	TH	-
	Vertical Active Blanking Period	TVB	TV-TVD	15	TV-TVD	TH	
	Horizontal Total Time	TH	1446	1494	1867	Tc	(2)
	Horizontal Active Display Period	THD	1366	1366	1366	Tc	(2)
	Horizontal Active Blanking Period	THB	TH-THD	128	TH-THD	Tc	(2)

Note (1) Because this module is operated by DE only mode, Hsync and Vsync are ignored.

(2) 2 channels LVDS input.

INPUT SIGNAL TIMING DIAGRAM

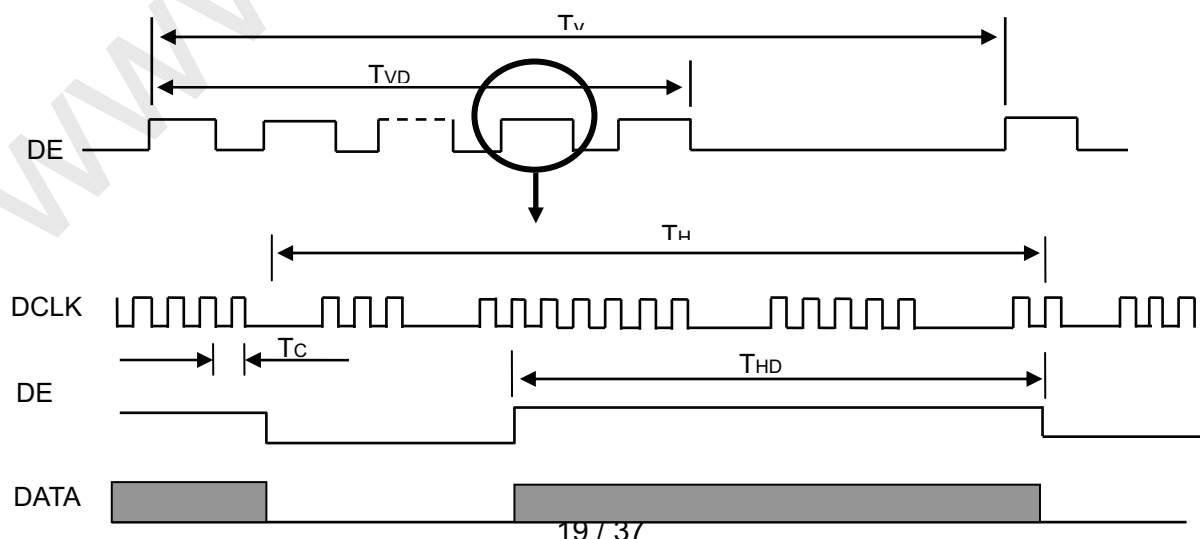

7.2 POWER ON/OFF SEQUENCE

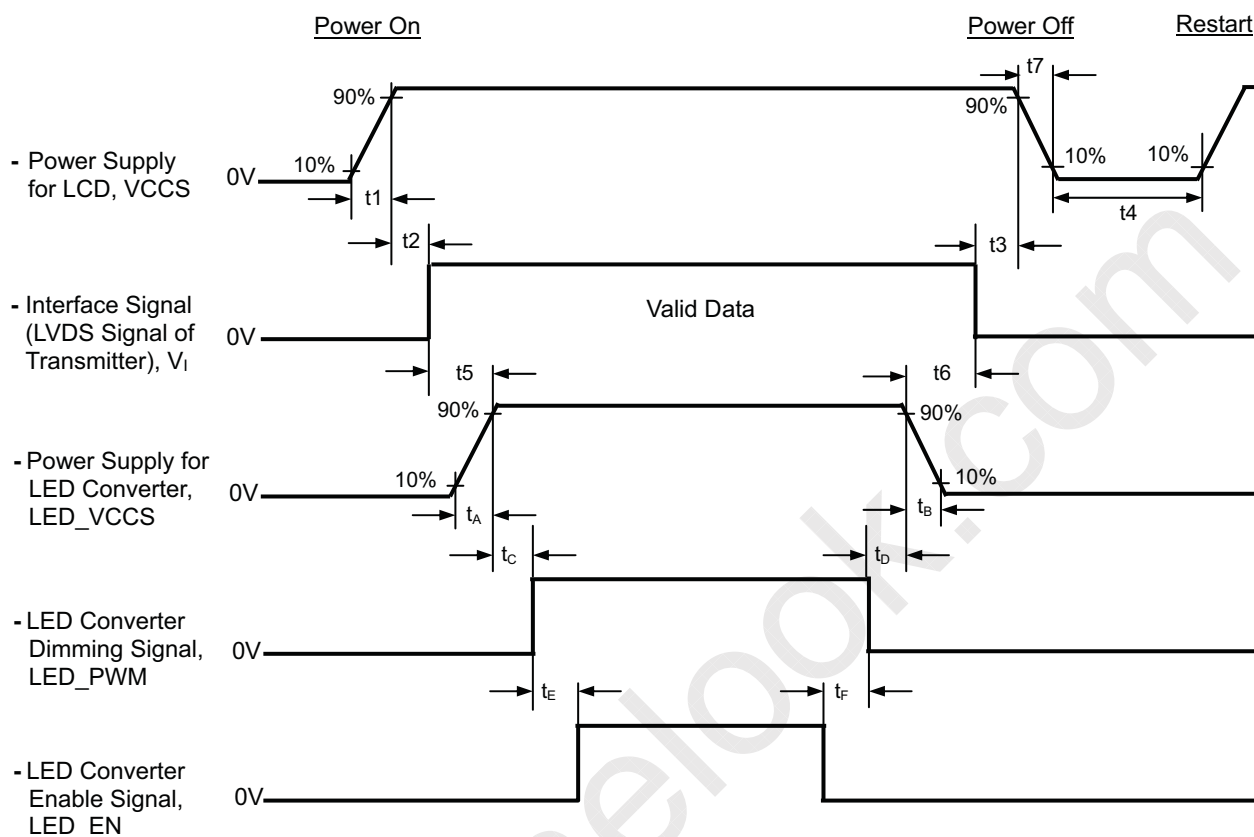

Timing Specifications:

$$0.5 \leq t_1 \leq 10 \text{ ms}$$

$$0 \leq t_2 \leq 50 \text{ ms}$$

$$0 \leq t_3$$

$$t_4 \geq 150 \text{ ms}$$

$$t_5 \geq 200 \text{ ms}$$

$$t_6 \geq 0 \text{ ms}$$

$$0 \leq t_7 \leq 10 \text{ ms}$$

$$t_C \geq 0 \text{ ms}$$

$$t_D \geq 0 \text{ ms}$$

$$t_E \geq 0 \text{ ms}$$

$$t_F \geq 0 \text{ ms}$$

- Note (1) Please follow the power on/off sequence described above. Otherwise, the LCD module might be damaged.
- Note (2) Please avoid floating state of interface signal at invalid period. When the interface signal is invalid, be sure to pull down the power supply of LCD Vcc to 0 V.
- Note (3) The Backlight converter power must be turned on after the power supply for the logic and the interface signal is valid. The Backlight converter power must be turned off before the power supply for the logic and the interface signal is invalid.
- Note (4) Please follow the LED converter power sequence as above. If the customer could not follow, it might cause backlight flash issue during display ON/OFF or damage the LED backlight controller

8. OPTICAL CHARACTERISTICS

8.1 TEST CONDITIONS

Item	Symbol	Value	Unit
Ambient Temperature	T _a	25±2	°C
Ambient Humidity	H _a	50±10	%RH
Supply Voltage	V _{CC}	3.3	V
Input Signal	According to typical value in "3. ELECTRICAL CHARACTERISTICS"		
Converter Current	I _L	120	mA

The measurement methods of optical characteristics are shown in Section 8.2. The following items should be measured under the test conditions described in Section 8.1 and stable environment shown in Note (5).

8.2 OPTICAL SPECIFICATIONS

Item		Symbol	Condition	Min.	Typ.	Max.	Unit	Note	
Contrast Ratio		CR	Viewing Normal Angle $\theta_x=0^\circ, \theta_y=0^\circ$	500	650	-	-	(2), (5)	
Response Time		T _R		-	3	5	ms	(3)	
		T _F		-	5	11	ms		
Average Luminance of White		L _{Ave}		190	220	-	cd/m ²	(4), (6)	
Color Chromaticity	Red	R _x		Viewing Normal Angle $\theta_x=0^\circ, \theta_y=0^\circ$	TYP. -0.03	0.623	TYP. +0.03	-	(1)
		R _y				0.345		-	
	Green	G _x				0.340		-	
		G _y				0.592		-	
	Blue	B _x				0.159		-	
		B _y				0.074		-	
	White	W _x	0.313			-			
		W _y	0.329			-			
Viewing Angle	Horizontal	θ_{x+}	CR≥10	40	45	-	Deg.	(1),(5)	
		θ_{x-}		40	45	-			
	Vertical	θ_{y+}		15	20	-			
		θ_{y-}		40	45	-			
White Variation of 5 Points		δW_{5p}	$\theta_x=0^\circ, \theta_y=0^\circ$	75			%	(5),(6)	
White Variation of 13 Points		δW_{13p}	$\theta_x=0^\circ, \theta_y=0^\circ$	60			%	(5),(7)	

Note (1) Definition of Viewing Angle (θ_x , θ_y):

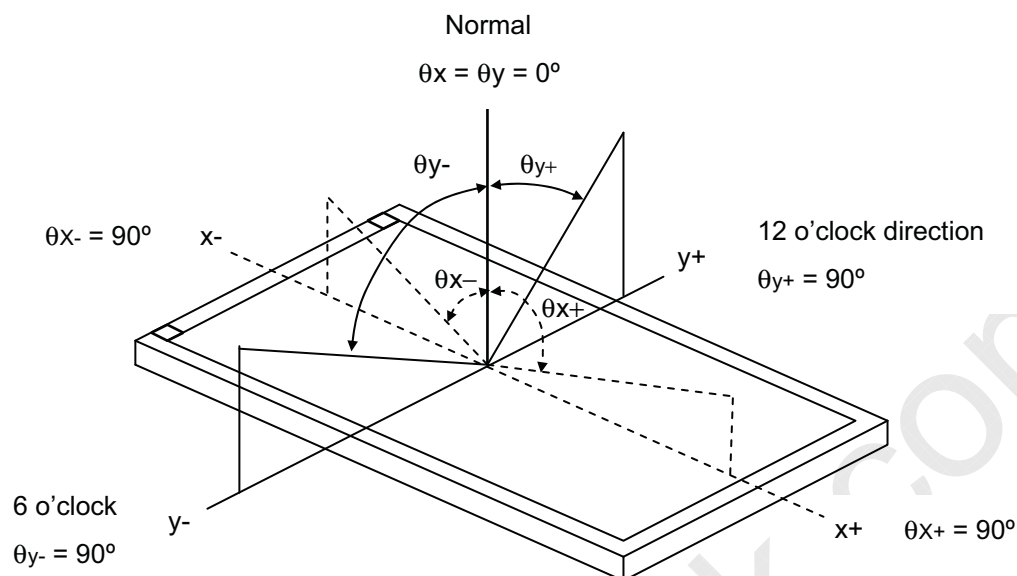

Note (2) Definition of Contrast Ratio (CR):

The contrast ratio can be calculated by the following expression.

$$\text{Contrast Ratio (CR)} = L_{63} / L_0$$

L63: Luminance of gray level 63

L 0: Luminance of gray level 0

$$\text{CR} = \text{CR} (1)$$

CR (X) is corresponding to the Contrast Ratio of the point X at Figure in Note (6).

Note (3) Definition of Response Time (T_R , T_F):

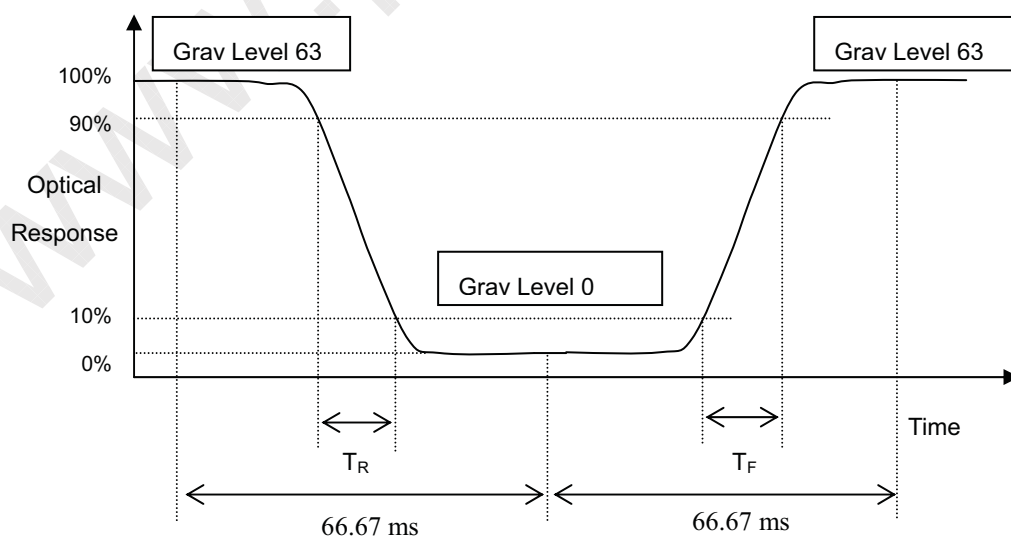

Note (4) Definition of Average Luminance of White (L_{AVE}):

Measure the luminance of gray level 63 at 5 points

$$L_{AVE} = [L(1) + L(2) + L(3) + L(4) + L(5)] / 5$$

$L(x)$ is corresponding to the luminance of the point X at Figure in Note (6)

Note (5) Measurement Setup:

The LCD module should be stabilized at given temperature for 20 minutes to avoid abrupt temperature change during measuring. In order to stabilize the luminance, the measurement should be executed after lighting Backlight for 20 minutes in a windless room.

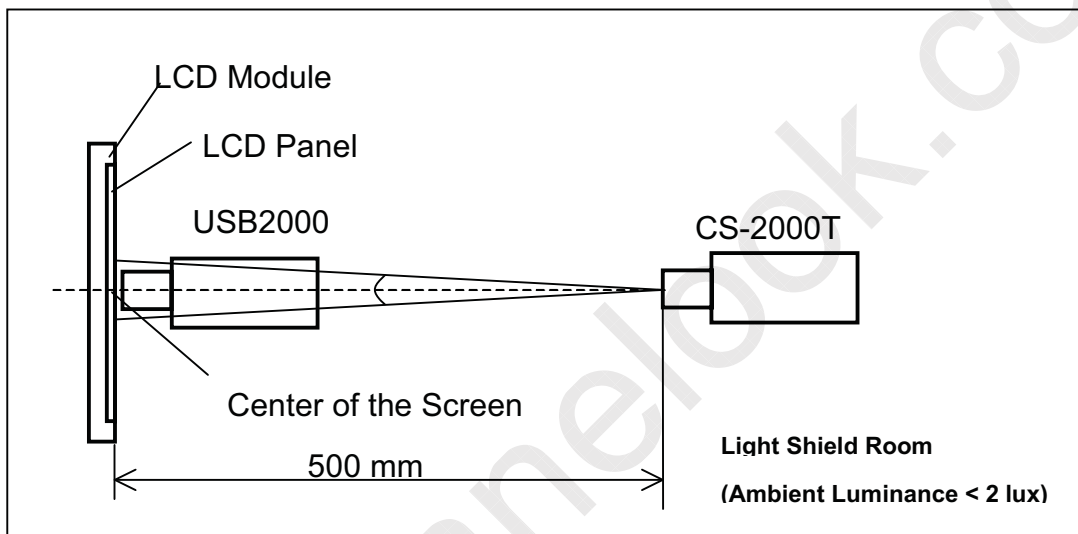

Note (6) Definition of White Variation (δW):

Measure the luminance of gray level 63 at 5 points

$$\delta W_{5p} = \text{Minimum} [L(1) + L(2) + L(3) + L(4) + L(5)] / \text{Maximum} [L(1) + L(2) + L(3) + L(4) + L(5)]$$

Note (7) Definition of White Variation (δW):

Measure the luminance of gray level 63 at 13 points

$$\delta W_{13p} = \text{Minimum} [L(1) + L(2) + L(3) + L(4) + L(5) + L(6) + L(7) + L(8) + L(9) + L(10) + L(11) + L(12) + L(13)] / \text{Maximum} [L(1) + L(2) + L(3) + L(4) + L(5) + L(6) + L(7) + L(8) + L(9) + L(10) + L(11) + L(12) + L(13)]$$

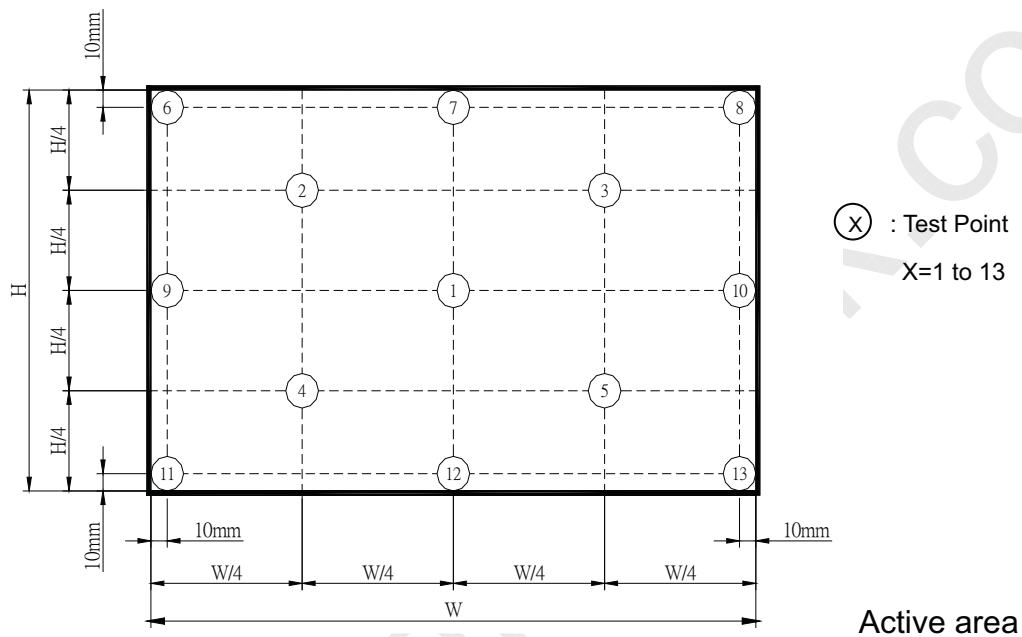

9. PRECAUTIONS

9.1 HANDLING PRECAUTIONS

- (1) The module should be assembled into the system firmly by using every mounting hole. Be careful not to twist or bend the module.
- (2) While assembling or installing modules, it can only be in the clean area. The dust and oil may cause electrical short or damage the polarizer.
- (3) Use fingerstalls or soft gloves in order to keep display clean during the incoming inspection and assembly process.
- (4) Do not press or scratch the surface harder than a HB pencil lead on the panel because the polarizer is very soft and easily scratched.
- (5) If the surface of the polarizer is dirty, please clean it by some absorbent cotton or soft cloth. Do not use Ketone type materials (ex. Acetone), Ethyl alcohol, Toluene, Ethyl acid or Methyl chloride. It might permanently damage the polarizer due to chemical reaction.
- (6) Wipe off water droplets or oil immediately. Staining and discoloration may occur if they left on panel for a long time.
- (7) If the liquid crystal material leaks from the panel, it should be kept away from the eyes or mouth. In case of contacting with hands, legs or clothes, it must be washed away thoroughly with soap.
- (8) Protect the module from static electricity, it may cause damage to the C-MOS Gate Array IC.
- (9) Do not disassemble the module.
- (10) Do not pull or fold the LED wire.
- (11) Pins of I/F connector should not be touched directly with bare hands.

9.2 STORAGE PRECAUTIONS

- (1) High temperature or humidity may reduce the performance of module. Please store LCD module within the specified storage conditions.
- (2) It is dangerous that moisture come into or contacted the LCD module, because the moisture may damage LCD module when it is operating.
- (3) It may reduce the display quality if the ambient temperature is lower than 10 °C. For example, the response time will become slowly, and the starting voltage of LED will be higher than the room temperature.

9.3 OPERATION PRECAUTIONS

- (1) Do not pull the I/F connector in or out while the module is operating.
- (2) Always follow the correct power on/off sequence when LCD module is connecting and operating. This can prevent the CMOS LSI chips from damage during latch-up.
- (3) The startup voltage of Backlight is approximately 1000 Volts. It may cause electrical shock while assembling with converter. Do not disassemble the module or insert anything into the Backlight unit.

10. PACKING

10.1 CARTON

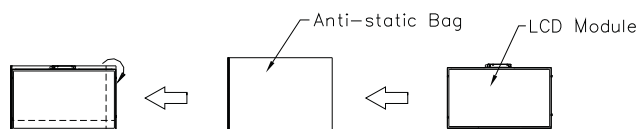

Box Dimensions : 489(L)*382(W)*320(H)
 Weight: Approx. 13.11kg(20 module .per. 1 box)

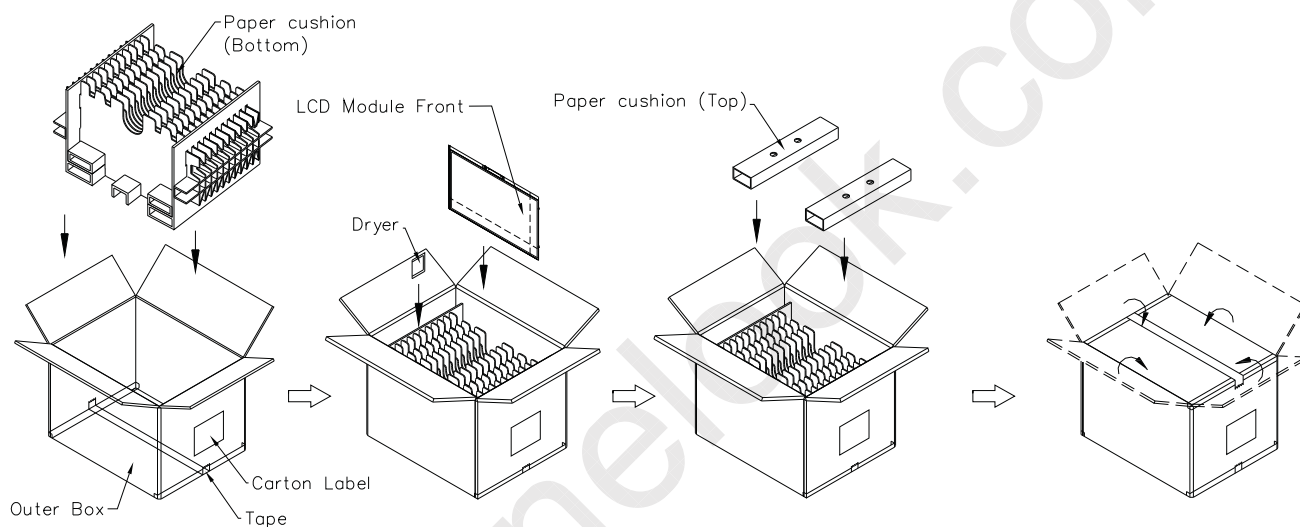

Figure. 10-1 Packing method

10.2 PALLET

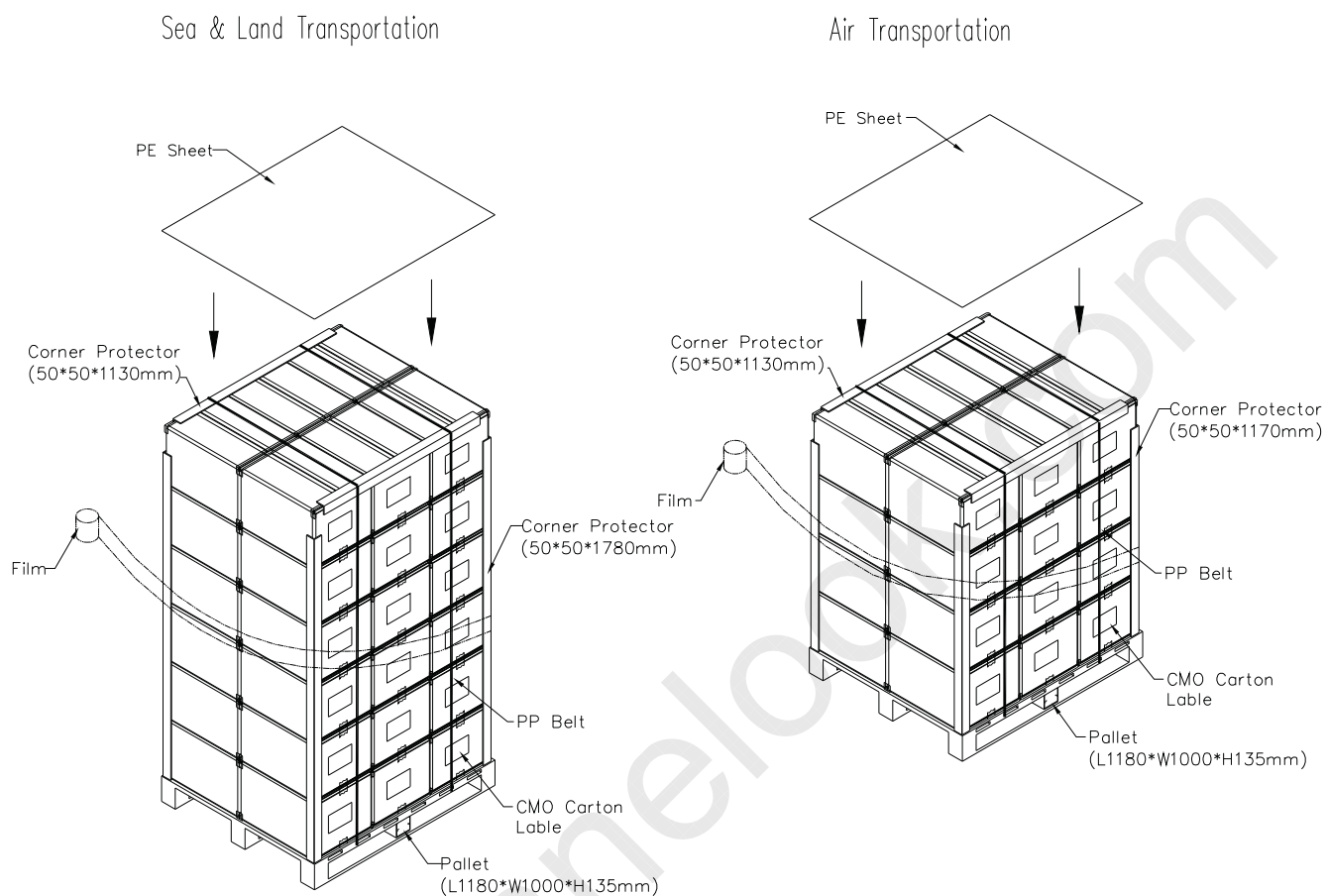

Figure. 10-2 Packing method

11. DEFINITION OF LABELS

11.1 CMO MODULE LABEL

The barcode nameplate is pasted on each module as illustration, and its definitions are as following explanation.



- (a) Model Name: N156B6-L07
 (b) Revision: Rev. XX, for example: A1, ..., C1, C2 ...etc.
 (c) Serial ID: XXXXXXYMDXNNNN

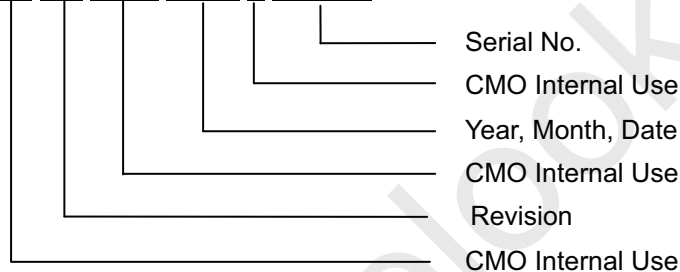

- (d) Production Location: MADE IN XXXX. XXXX stands for production location.
 (e) UL/CB logo: LBOO especially stands for panel manufactured by CMO NingBo satisfying UL/CB requirement. The panel without LBOO mark stands for manufactured by CMO Taiwan satisfying UL/CB requirement.

Serial ID includes the information as below:

- (a) Manufactured Date: Year: 1~9, for 2001~2009
 Month: 1~9, A~C, for Jan. ~ Dec.
 Day: 1~9, A~Y, for 1st to 31st, exclude I, O and U
 (b) Revision Code: cover all the change
 (c) Serial No.: Manufacturing sequence of product

For Lenovo's barcode content

11S PPPPPP Z1Z HHH SSSSS YMM (11S42T0649Z1ZFKXSSSSSS 601)

- (a) 11S: Fixed characters.
 (b) PPPPPP (P/N): Customer part number, fixed characters (N156B6-L07 current is 42T0649)
 (c) Z1Z: Fixed characters.
 (d) HHH (Header Code): FKX
 (e) SSSSS: Series number.
 (f) YMM: Y: The last character of year. MM: Month

11.2 CMO CARTON LABEL

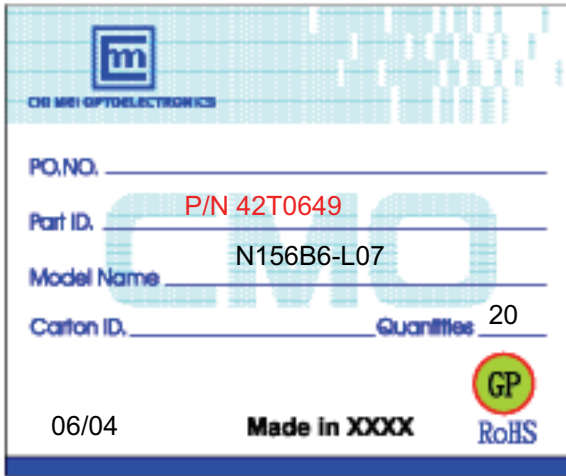

The image shows a CMO Carton Label with a blue header and a white body. The header contains the CHI MEI logo and the text 'CHI MEI OPTOELECTRONICS'. The body contains the following information:

PO.NO.	_____
Part ID.	P/N 42T0649
Model Name	N156B6-L07
Carton ID.	_____
Quantities	20

At the bottom left, it says '06/04'. At the bottom center, it says 'Made in XXXX'. At the bottom right, there is a 'GP' logo and 'RoHS' text.

(a) Production location: Made In XXXX. XXXX stands for production location.

12 Inspection Standards for LCD Modules

12.1 Description

These inspection standards shall be applied to LCD Module supplied by CHI MEI Optoelectronics Corporation.

12.2 The environmental condition of inspection

The environmental condition and visual inspection shall be conducted as below.

- (1) Ambient temperature : 15~25 °C
- (2) Humidity: 25~75 %RH
- (3) External appearance inspection shall be conducted by using a single 20W fluorescent lamp or equivalent illumination.
- (4) Panel visual inspection on the operation condition for cosmetic shall be conducted at the distance 30cm between the LCD module and eyes of inspector

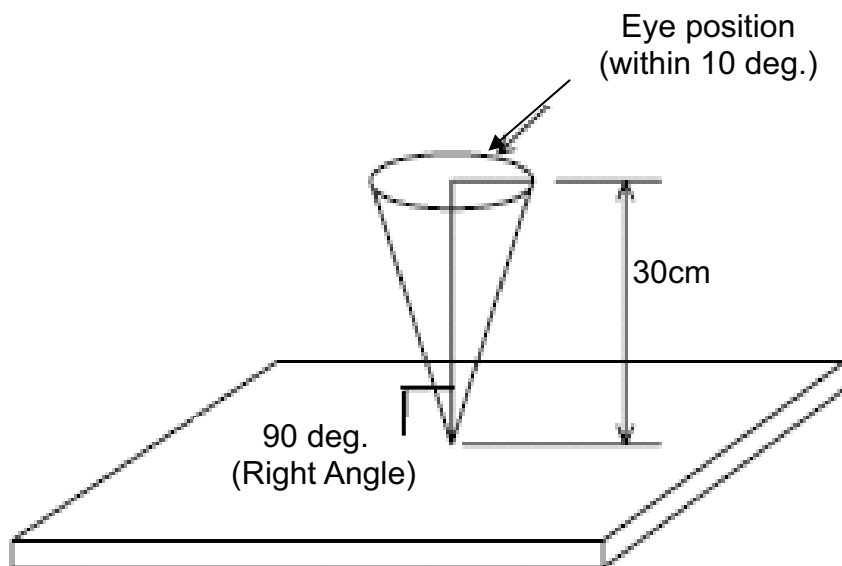

12.3 Classification of defects

Defects are classified two types, major defect and minor defect according to the defect.

And, the definition of defects is classified as below.

(1) Major defect

Any defect may result in functional failure, or reduce the usability of product for its purpose. For example, electrical failure, deformation and etc..

(2) Minor defect

A defect that is not to reduce the usability of product for its intended purpose and un-uniformity, dot defect and etc..

The criteria on major and/or minor judgement will be according with the classification of defects.

12.4 Inspection Criteria

(1) Definition of dot defect

Define spec for 2 dot adjacent and minimum distance

2-adjacent(Linked Pixels)

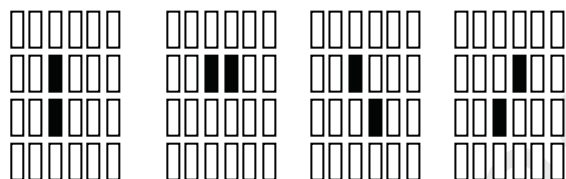

□ : sub-Pixel(R,G,B)

Minimum Distance;

Lit to Lit : $L \geq 15\text{mm}$

Unlit to Unlit : $L \geq 5\text{mm}$

Lit to Unlit : Not Applicable

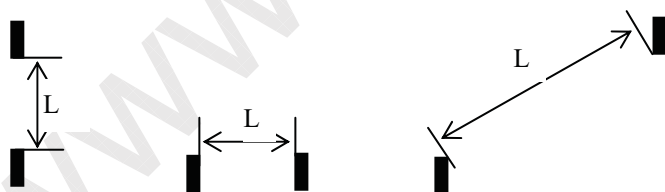

L: Sub-Pixel to Sub-Pixel, Sub-Pixel to 2-adjacent or 2-adjacent to 2-adjacent

(2) Display Inspection

- (a) Ambient Luminance: 250 Lux or more for light on inspection
- (b) Viewing Angle: Within LCD Viewing Angle Specification
- (c) Inspection Pattern : In Black, White, Red, Green, Blue and 32-Gray(Half-Gray) Screens

Items		Acceptable count
Bright dot	Random	$N \leq 2$ (Green ≤ 1)
	2 dots adjacent	$N \leq 0$
	3 dots adjacent or more	$N \leq 0$
Dark dot	Random	$N \leq 3$
	2 dots adjacent	$N \leq 1$
	3 dots adjacent or more	$N \leq 0$
Distance	Minimum Distance Between Bright dots	$L \geq 15\text{mm}$
	Minimum Distance Between Dark dots	$L \geq 5\text{mm}$
	Lit to Unlit	Not Applicable
Total bright and dark dot		$N \leq 5$
Dot(Lit/Unlit) : Noticeable defective dots in the office environment (250 lux) will be counted regardless of defective dot size		
Display failure (V-line/H-line/Cross line etc.)		Not allowable
Mura	Not visible through 8% ND filter or judge by limit sample if necessary	

- (3) Appearance inspection
- (a) Ambient Illumination : 500~700 Lux
- (b) View angle: Backlight-Off Condition : At Right Angle To Polarizer Surface
Backlight-On Condition Within LCD Viewing Angle Specification
- (c) Inspection Pattern: In white and 32-Gray (Half-Gray) Screens(Backlight-On)

Items	Size(mm)	Acceptable count
1. Scratch(Line Shape) : B/L -off condition	$W < 0.05$	Ignore
	$0.05 \leq W < 0.1; 0.3 \leq L \leq 3.0$	$N \leq 4$
	$0.10 \leq W$ or $3.0 < L$	$N = 0$
	Shall be no visible at backlight-on	
2. Dent : B/L -on/off condition	$D < 0.2$	Ignore
	$0.2 \leq D < 0.5$	$N \leq 5$
	$0.5 \leq D$	$N = 0$
	Spacing between defects shall be more than 30 mm. ($0.2 \leq D < 0.5$) Shall be no visible at B/L on.	
3. Bubble : B/L -off condition	$D < 0.2$	Ignore
	$0.2 \leq D < 0.5$	$N \leq 5$
	$0.5 \leq D$	$N = 0$
	Shall be no visible at B/L on.	
4. Foreign material (Line-shape:stain inclusion) :B/L-on condition	$W < 0.05$	Ignore
	$0.05 \leq W < 0.1; 0.3 \leq L \leq 2.0$	$N \leq 4$
	$0.1 < W$ or $2.0 < L$	$N = 0$
5. Foreign material (Dot-shape:stain inclusion) :B/L-on condition	$D < 0.2$	Ignore
	$0.2 \leq D < 0.5$	$N \leq 5$
	$0.5 \leq D$	$N = 0$
6. Peeling on Polizer edge :B/L-off condition	$D < 0.2$	Ignore
	$0.2 \leq D < 0.5$	$N \leq 5$
	$0.5 \leq D$	$N = 0$
	Bubble or glue shall not be visible within PC bezel opening area with specified inspection viewing angle.	
	Continuous peeling off on polarizer edge shall be discussed. Shall be no visible at backlight-on	

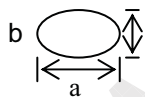

$$D = (a+b)/2$$

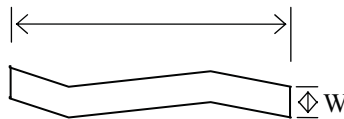

W: width, L : length

12.5 External Appearance Inspection Criteria

Item	Contents	
Screw	Parts mounting, incomplete assembly, deformation, oxidized, crooked or rusty is not permitted.	
CCFT cable	Cable not continuous 、 Break-off 、 Connector Burn-off /Break-off	
Metal frame (Bezel)	Scratch	*Noticeable scratch and exfoliation coating are not permitted. *The oxidized metal is not permitted.
	Incomplete assembly is not permitted.	
Backlight	Scratch	The scratch which may causes a problem in practical use is not permitted.
	Break-off	Breaking off is not permitted.
	Crack	The crack is not permitted.
Stain on Polarizer	The stain which can't be wiped off is not permitted.	
Tape/Label	Incorrect position, missed label is not permitted.	
Connector	Oxidized/rusty connector is not permitted.	
Outline size	Spec. out is not permitted.	

12.6 Classification of defects

Inspection Item	Criteria and Description	Defect type
Vertical line	Signal input, vertical line off or irregular V-line appears	major
Horizontal line	Signal input, horizontal line off or irregular H-line appears	major
Cross line	Pattern signal input, a correct display is not obtained	major
No display	Signal input, display is dead	major
Irregular display	Pattern signal input, a correct display is not obtained	major
Dots defect	Exceed specified standards	minor
Scratch and Dent on polarizer	Exceed specified standards	minor
Foreign material	Exceed specified standards	minor
Mura	Not visible through 6% ND filter or judge by limit sample	minor
External Appearance	Rust, deformation, irregular plating, coating missing etc. A appearance defect that do not affect function or performance	minor
Bezel claw	Bezel claw missing or not bent	major
Polarizer bubble	Exceed specified standards	minor
Flicker	Signal input, Flicker appears	major

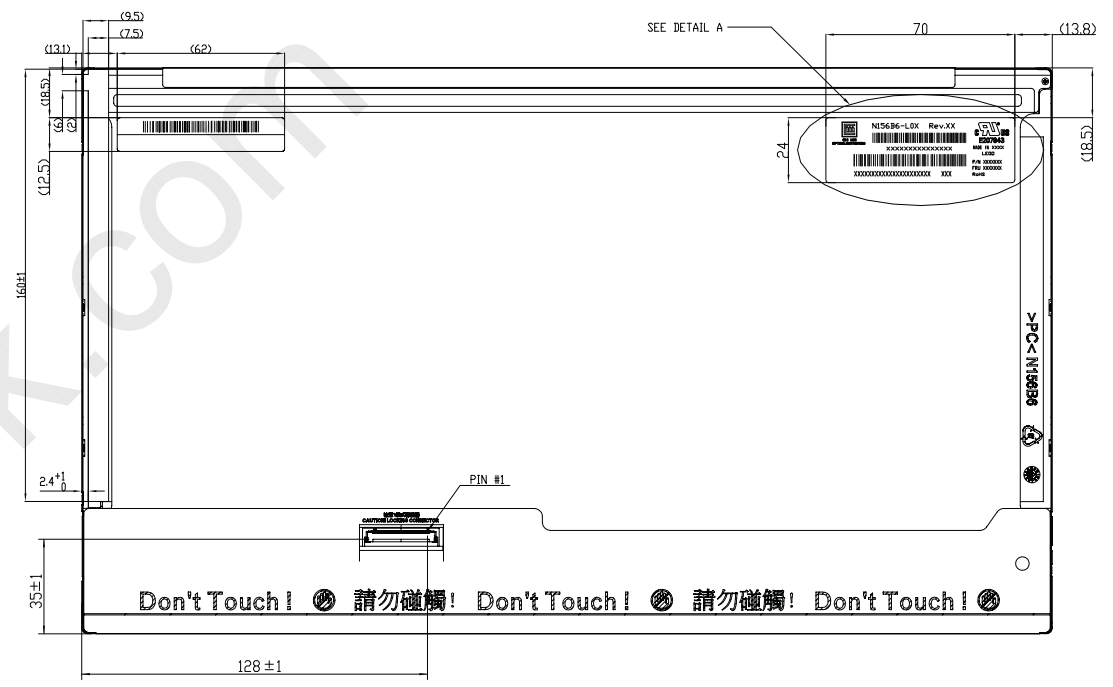
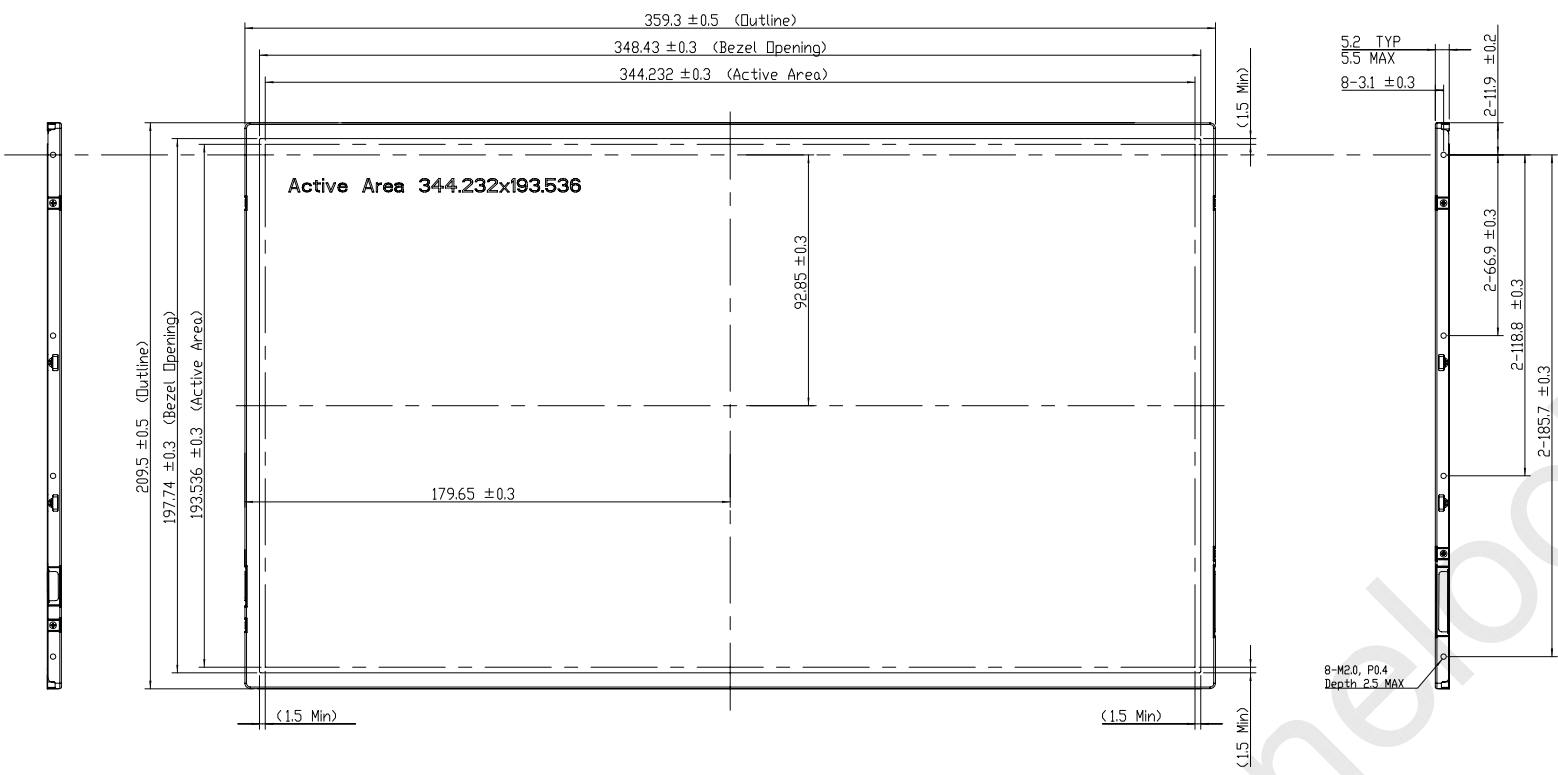

- NOTES:
 1. Max screw length: 2.5mm.
 2. Max screw torque: 2.0 kgf-cm.
 3. LCD module input connector: I-PEX 20455-040E-12 or equivalent.
 4. Gap between bezel and panel: 0.5mm MAX.
 5. In order to avoid abnormal display, pooling and white spot, no overlapping is suggested at cables, antennas, camera, WLAN, WAN or other foreign objects over CDF driver IC, TCDN and VR locations.
 6. Max module flatness: 0.5mm.

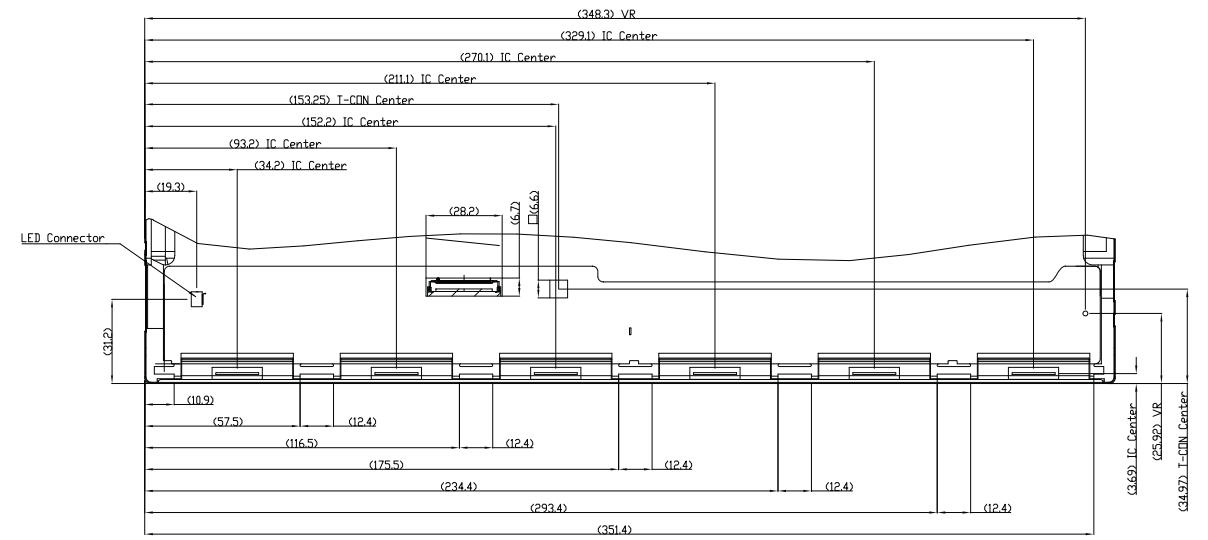

CDF AND IC CENTER LOCATION
 SEE NOTE 5 FOR EXPLANATION.

Mark	Description	Date	Changed_By	Approved_By	ECN No.	Remark
1						
2						
3						
4						

TITLE: OUTLINE DRAWING N156B6-L0X		2D REV: A	
Approved	Bill Sheu	Drawing No.	N1563415A
Checked	Chany Chen	Part No.	NA
Drawer	Yehh	Material	NA
Designer	Julie Lien	Date	26-Aug-2009
		Scale	1:1
		Sheet	1 / 1
		Unit	mm