

Doc. Number:

- Tentative Specification
- Preliminary Specification
- Approval Specification

MODEL NO.: N156BGE

SUFFIX: E31

| | |
|--|------------------|
| Customer: | |
| APPROVED BY | SIGNATURE |
| Name / Title _____ | _____ |
| Note | |
| <hr/> Please return 1 copy for your confirmation with your signature and comments. | |

| | | |
|---|--|--|
| Approved By 楊竣傑 2013-03-29 18:33:22 CST | Checked By 曹文彬 2013-03-27 16:56:13 CST | Prepared By 孫莉 2013-03-04 18:20:09 CST |
|---|--|--|

CONTENTS

| | |
|--|-----------|
| 1. GENERAL DESCRIPTION | 4 |
| 1.1 OVERVIEW | 4 |
| 1.2 GENERAL SPECIFICATIONS | 4 |
| 2. MECHANICAL SPECIFICATIONS | 5 |
| 2.1 CONNECTOR TYPE | 5 |
| 3. ABSOLUTE MAXIMUM RATINGS | 6 |
| 3.1 ABSOLUTE RATINGS OF ENVIRONMENT | 6 |
| 3.2 ELECTRICAL ABSOLUTE RATINGS..... | 6 |
| 3.2.1 TFT LCD MODULE | 6 |
| 4. ELECTRICAL SPECIFICATIONS..... | 7 |
| 4.1 FUNCTION BLOCK DIAGRAM..... | 7 |
| 4.2. INTERFACE CONNECTIONS | 7 |
| 4.3 ELECTRICAL CHARACTERISTICS..... | 9 |
| 4.3.1 LCD ELETRONICS SPECIFICATION | 9 |
| 4.3.2 LED CONVERTER SPECIFICATION..... | 11 |
| 4.3.3 BACKLIGHT UNIT | 13 |
| 4.4 INPUT SIGNAL TIMING SPECIFICATIONS | 14 |
| 4.4.1 DISPLAY PORT INTERFACE | 14 |
| 4.4.2 COLOR DATA INPUT ASSIGNMENT | 15 |
| 4.5 DISPLAY TIMING SPECIFICATIONS | 16 |
| 4.6 POWER ON/OFF SEQUENCE | 17 |
| 5. OPTICAL CHARACTERISTICS | 19 |
| 5.1 TEST CONDITIONS..... | 19 |
| 5.2 OPTICAL SPECIFICATIONS | 19 |
| 6. RELIABILITY TEST ITEM | 22 |
| 7. PACKING | 23 |
| 7.1 MODULE LABEL | 23 |
| 7.2 CARTON | 24 |
| 7.3 PALLET..... | 24 |
| 7.3 PALLET..... | 25 |
| 8. PRECAUTIONS | 26 |
| 8.1 HANDLING PRECAUTIONS..... | 26 |
| 8.2 STORAGE PRECAUTIONS | 26 |
| 8.3 OPERATION PRECAUTIONS..... | 26 |
| Appendix. EDID DATA STRUCTURE..... | 27 |
| Appendix. OUTLINE DRAWING | 30 |
| Appendix. SYSTEM COVER DESIGN GUIDANCE..... | 32 |

REVISION HISTORY

| Version | Date | Page | Description |
|---------|---------------|------|--|
| 1.0 | Dec. 08, 2012 | All | Preliminary Specification Ver.1.0 was first issued. |
| 1.1 | Mar. 01, 2013 | All | Change logo & content from "CHIMEI INNOLUX" to "INNOLUX" |
| | | 31 | Modify "Appendix. SYSTEM COVER DESIGN GUIDANCE" |
| | | | |
| | | | |
| | | | |
| | | | |
| | | | |

1. GENERAL DESCRIPTION

1.1 OVERVIEW

N156BGE-E31 is a 15.6" (15.6" diagonal) TFT Liquid Crystal Display module with LED Backlight unit and 30 pins eDP interface. This module supports 1366 x 768 HD mode and can display 262,144 colors. The optimum viewing angle is at 6 o'clock direction.

1.2 GENERAL SPECIFICATIONS

| Item | Specification | Unit | Note |
|-------------------|---|-------|------|
| Screen Size | 15.6" diagonal | | |
| Driver Element | a-si TFT active matrix | - | - |
| Pixel Number | 1366 x R.G.B. x 768 | pixel | - |
| Pixel Pitch | 0.252 (H) x 0.252 (V) | mm | - |
| Pixel Arrangement | RGB vertical stripe | - | - |
| Display Colors | 262,144 | color | - |
| Transmissive Mode | Normally white | - | - |
| Surface Treatment | Hard coating (3H), Anti-Glare | - | - |
| Luminance, White | 200 | Cd/m2 | |
| Power Consumption | Total (2.86) W (Max.) @ cell (1.0) W (Max.), BL (1.86) W (Max.) | | (1) |

Note (1) The specified power consumption (with converter efficiency) is under the conditions at VCCS = 3.3 V, fv = 60 Hz, LED_VCCS = Typ, fPWM = 200 Hz, Duty=100% and Ta = 25 ± 2 °C, whereas Mosaic pattern is displayed.

2. MECHANICAL SPECIFICATIONS

| Item | Min. | Typ. | Max. | Unit | Note | |
|-------------|---------------------------------|---------|---------|---------|------|-----|
| Module Size | Horizontal (H) | 359 | 359.5 | 360 | mm | (1) |
| | Vertical (V) w/o PCB and Hinge | 206 | 206.5 | 207 | mm | |
| | Vertical (V) with PCB w/o Hinge | 217 | 217.5 | 218 | mm | |
| | Thickness (T) | - | 3.5 | 3.8 | mm | |
| Bezel Area | Horizontal | 347.06 | 347.36 | 347.66 | mm | |
| | Vertical | 196.29 | 196.59 | 196.89 | mm | |
| Active Area | Horizontal | 343.932 | 344.232 | 344.532 | mm | |
| | Vertical | 193.236 | 193.536 | 193.836 | mm | |
| Weight | - | 410 | 425 | g | | |

Note (1) Please refer to the attached drawings for more information of front and back outline dimensions.

2.1 CONNECTOR TYPE

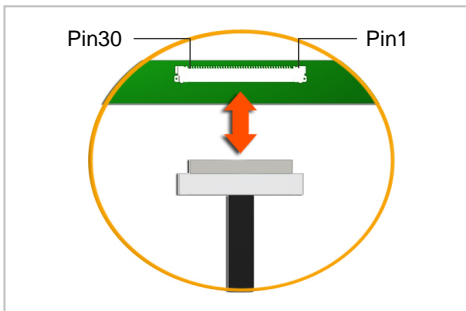

Please refer Appendix Outline Drawing for detail design.

Connector Part No.: IPEX-20455-030E-12

User's connector Part No: IPEX-20453-030T-01

3. ABSOLUTE MAXIMUM RATINGS

3.1 ABSOLUTE RATINGS OF ENVIRONMENT

| Item | Symbol | Value | | Unit | Note |
|-------------------------------|-----------------|-------|------|------|----------|
| | | Min. | Max. | | |
| Storage Temperature | T _{ST} | -20 | +60 | °C | (1) |
| Operating Ambient Temperature | T _{OP} | 0 | +50 | °C | (1), (2) |

Note (1) (a) 90 %RH Max. (Ta <= 40 °C).

(b) Wet-bulb temperature should be 39 °C Max. (Ta > 40 °C).

(c) No condensation.

Note (2) The temperature of panel surface should be 0 °C min. and 60 °C max.

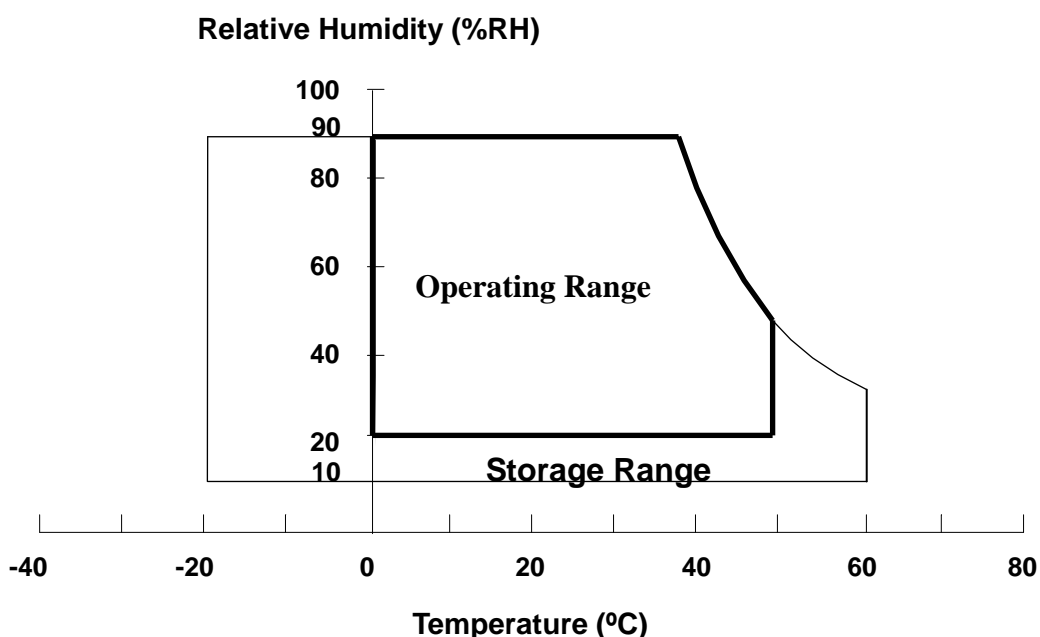

3.2 ELECTRICAL ABSOLUTE RATINGS

3.2.1 TFT LCD MODULE

| Item | Symbol | Value | | Unit | Note |
|----------------------------------|-----------------|-------|----------|------|------|
| | | Min. | Max. | | |
| Power Supply Voltage | VCCS | -0.3 | +4.0 | V | (1) |
| Logic Input Voltage | V _{IN} | -0.3 | VCCS+0.3 | V | |
| Converter Input Voltage | LED_VCCS | -0.3 | (26) | V | (1) |
| Converter Control Signal Voltage | LED_PWM, | -0.3 | (5) | V | (1) |
| Converter Control Signal Voltage | LED_EN | -0.3 | (5) | V | (1) |

Note (1) Stresses beyond those listed in above “ELECTRICAL ABSOLUTE RATINGS” may cause permanent damage to the device. Normal operation should be restricted to the conditions described in “ELECTRICAL CHARACTERISTICS”.

4. ELECTRICAL SPECIFICATIONS

4.1 FUNCTION BLOCK DIAGRAM

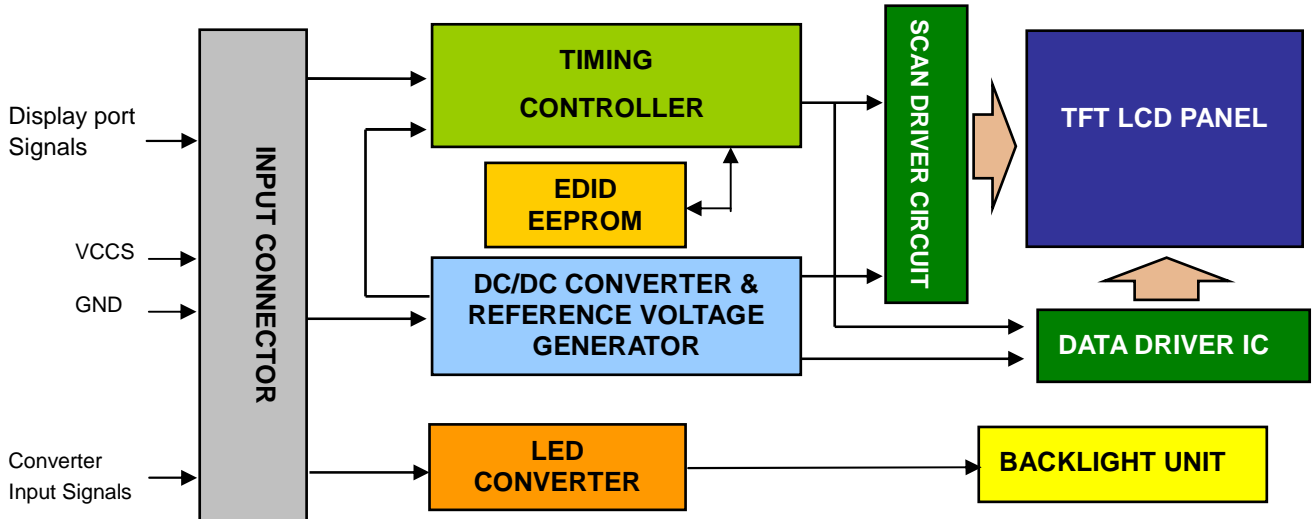

4.2. INTERFACE CONNECTIONS

PIN ASSIGNMENT

| Pin | Symbol | Description | Remark |
|-----|---------|---|--------|
| 1 | NC | No Connection (Reserved) | |
| 2 | H_GND | High Speed Ground | |
| 3 | NC | No Connection (Reserved) | |
| 4 | NC | No Connection (Reserved) | |
| 5 | H_GND | High Speed Ground | |
| 6 | ML0- | Complement Signal-Lane 0 | |
| 7 | ML0+ | True Signal-Main Lane 0 | |
| 8 | H_GND | High Speed Ground | |
| 9 | AUX+ | True Signal-Auxiliary Channel | |
| 10 | AUX- | Complement Signal-Auxiliary Channel | |
| 11 | H_GND | High Speed Ground | |
| 12 | VCCS | Power Supply +3.3 V (typical) | |
| 13 | VCCS | Power Supply +3.3 V (typical) | |
| 14 | NC | No Connection (Reserved for INNOLUX test) | |
| 15 | GND | Ground | |
| 16 | GND | Ground | |
| 17 | HPD | Hot Plug Detect | |
| 18 | BL_GND | BL Ground | |
| 19 | BL_GND | BL Ground | |
| 20 | BL_GND | BL Ground | |
| 21 | BL_GND | BL Ground | |
| 22 | LED_EN | BL_Enable Signal of LED Converter | |
| 23 | LED_PWM | PWM Dimming Control Signal of LED Converter | |
| 24 | NC | No Connection | |

| | | | |
|----|----------|--------------------------|--|
| 25 | NC | No Connection | |
| 26 | LED_VCCS | BL Power | |
| 27 | LED_VCCS | BL Power | |
| 28 | LED_VCCS | BL Power | |
| 29 | LED_VCCS | BL Power | |
| 30 | NC | No Connection (Reserved) | |

Note (1) The first pixel is odd as shown in the following figure.

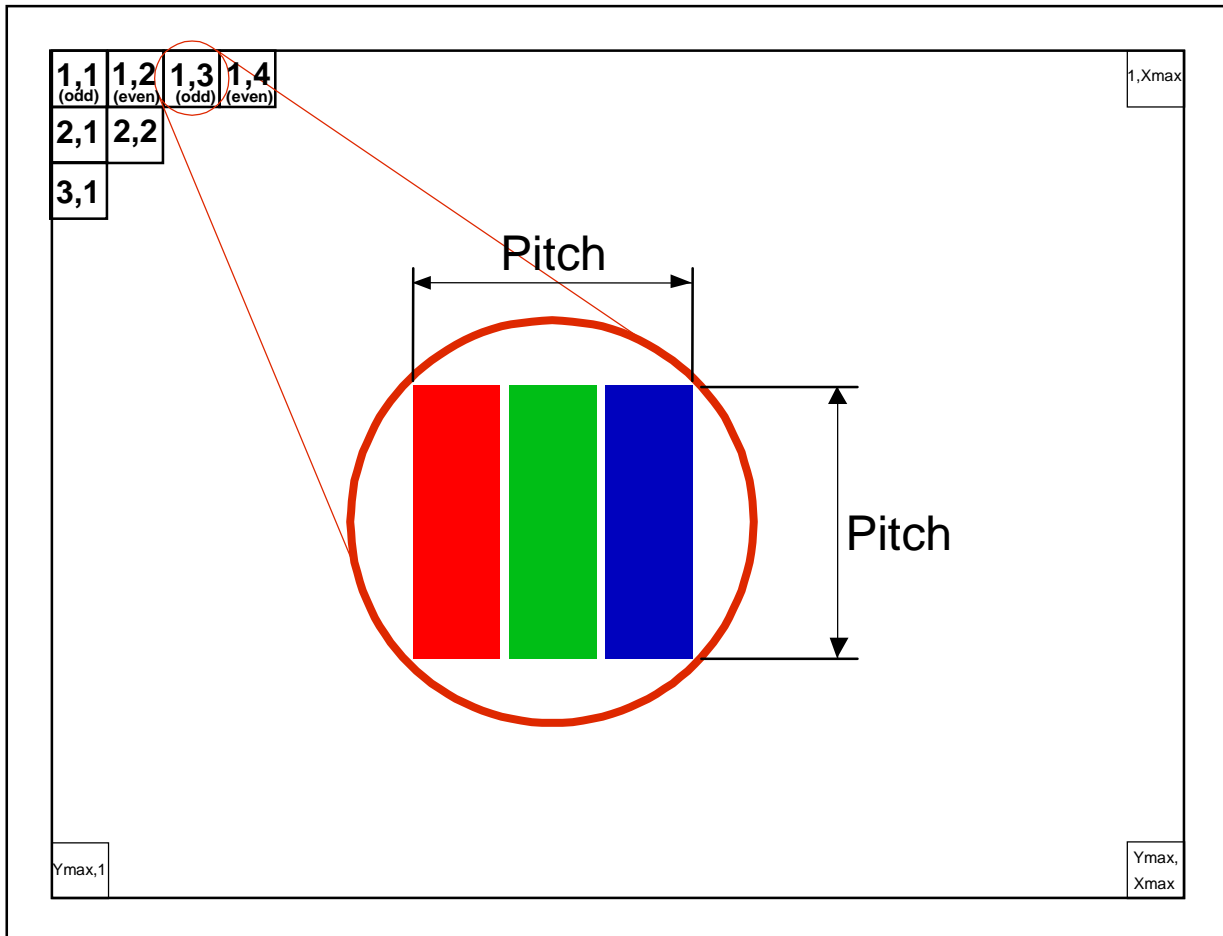

4.3 ELECTRICAL CHARACTERISTICS

4.3.1 LCD ELETRONICS SPECIFICATION

| Parameter | | Symbol | Value | | | Unit | Note |
|----------------------|------------|------------|--------|-------|--------|------|---------|
| | | | Min. | Typ. | Max. | | |
| Power Supply Voltage | | VCCS | 3.0 | 3.3 | 3.6 | V | (1)- |
| HPD | High Level | | (2.25) | - | (2.75) | V | |
| | Low Level | | (0) | - | (0.4) | V | |
| Ripple Voltage | | V_{RP} | - | (50) | - | mV | (1)- |
| Inrush Current | | I_{RUSH} | - | - | (1.5) | A | (1),(2) |
| Power Supply Current | Mosaic | I_{CC} | - | (250) | (300) | mA | (3)a |
| | Black | | - | (300) | (340) | mA | (3) |

Note (1) The ambient temperature is $T_a = 25 \pm 2 \text{ }^\circ\text{C}$.

Note (2) I_{RUSH} : the maximum current when VCCS is rising

I_{IS} : the maximum current of the first 100ms after power-on

Measurement Conditions: Shown as the following figure. Test pattern: black.

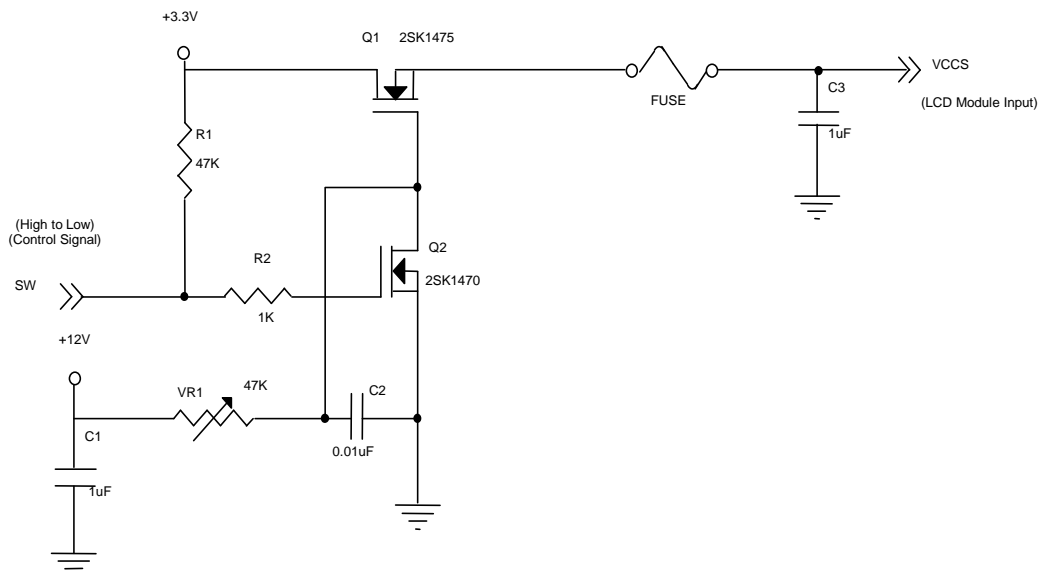

VCCS rising time is 0.5ms

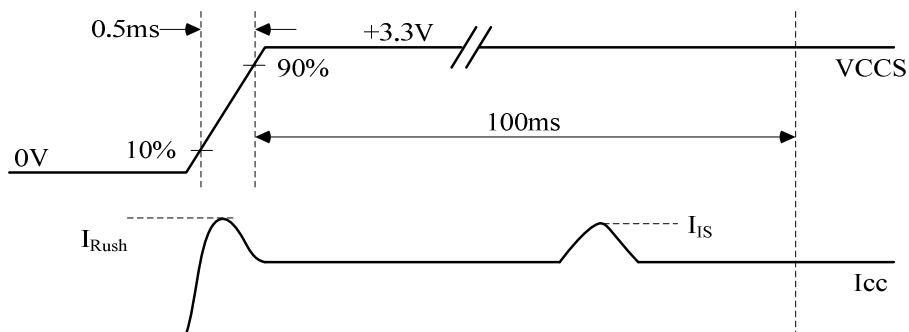

Note (3) The specified power supply current is under the conditions at $V_{CCS} = 3.3\text{ V}$, $T_a = 25 \pm 2\text{ }^\circ\text{C}$, DC Current and $f_v = 60\text{ Hz}$, whereas a power dissipation check pattern below is displayed.

a. Mosaic Pattern

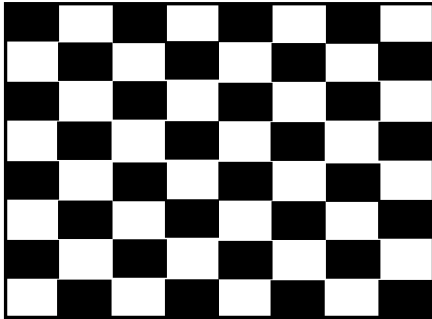

Active Area

4.3.2 LED CONVERTER SPECIFICATION

| Parameter | | Symbol | Value | | | Unit | Note |
|--|----------------|-----------------------|-------|--------|--------|------|------|
| | | | Min. | Typ. | Max. | | |
| Converter Input power supply voltage | | LED_Vccs | (5.0) | (12.0) | (21.0) | V | |
| Converter Inrush Current | | I _{LED_RUSH} | - | - | (1.5) | A | (1) |
| EN Control Level | Backlight On | | (2.2) | - | (5) | V | |
| | Backlight Off | | (0) | - | (0.6) | V | |
| PWM Control Level | PWM High Level | | (2.2) | - | (5) | V | |
| | PWM Low Level | | (0) | - | (0.6) | V | |
| PWM Control Duty Ratio | | | (5) | - | (100) | % | |
| PWM Control Permissible Ripple Voltage | | V _{PWM_pp} | - | - | (100) | mV | |
| PWM Control Frequency | | f _{PWM} | (190) | - | (2K) | Hz | (2) |
| LED Power Current | LED_VCCS =Typ. | I _{LED} | (116) | (145) | (163) | mA | (3) |

Note (1) I_{LED_RUSH}: the maximum current when LED_VCCS is rising,

I_{LED_{IS}}: the maximum current of the first 100ms after power-on,

Measurement Conditions: Shown as the following figure. LED_VCCS = Typ, Ta = 25 ± 2 °C, f_{PWM} = 200 Hz, Duty=100%.

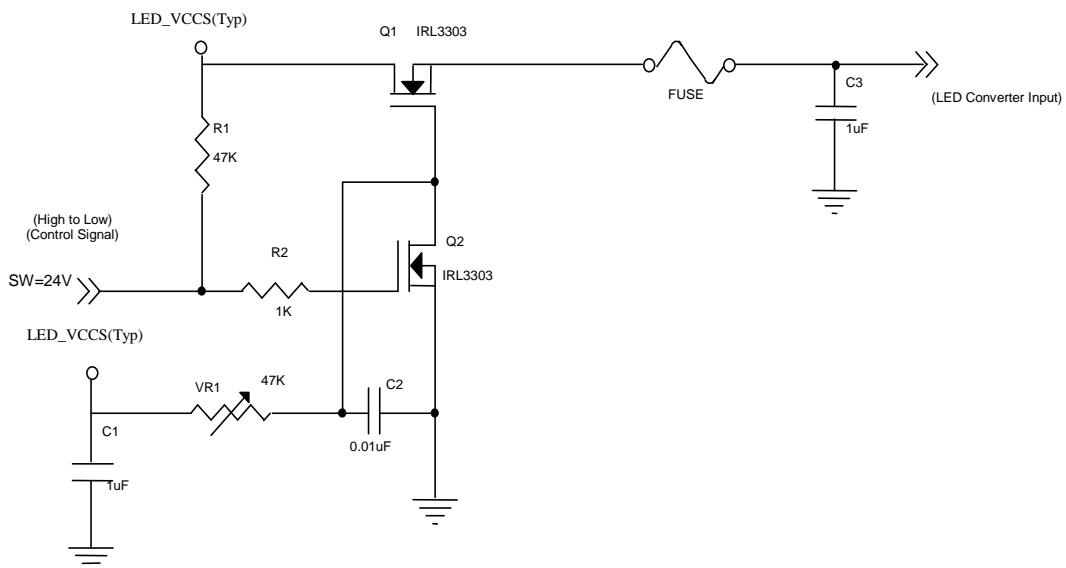

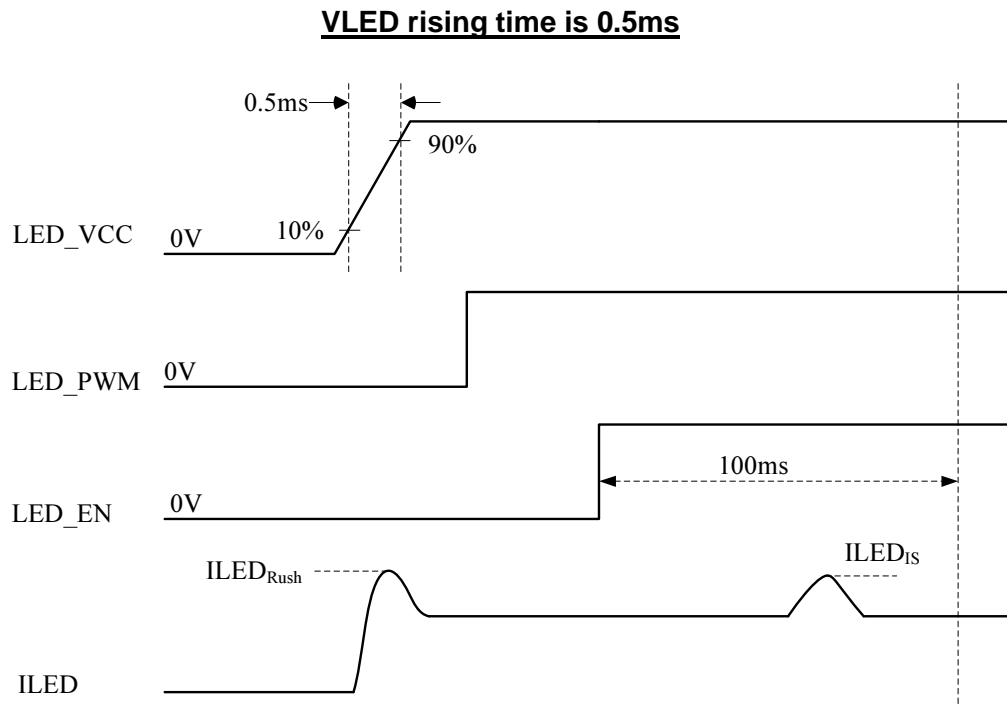

Note (3) If PWM control frequency is applied in the range less than 1KHz, the “waterfall” phenomenon on the screen may be found. To avoid the issue, it’s a suggestion that PWM control frequency should follow the criterion as below.

PWM control frequency f_{PWM} should be in the range

$$(N + 0.33) * f \leq f_{PWM} \leq (N + 0.66) * f$$

N : Integer ($N \geq 3$)

f : Frame rate

Note (4) The specified LED power supply current is under the conditions at “LED_VCCS = Typ.”, $T_a = 25 \pm 2 \text{ }^\circ\text{C}$, $f_{PWM} = 200 \text{ Hz}$, Duty=100%.

4.3.3 BACKLIGHT UNIT

Ta = 25 ± 2 °C

| Parameter | Symbol | Value | | | Unit | Note |
|------------------------------------|-----------------|-------|-------|-------|------|------------------|
| | | Min. | Typ. | Max. | | |
| LED Light Bar Power Supply Voltage | V _L | 27.5 | 30.8 | 33 | V | (1)(2)(Duty100%) |
| LED Light Bar Power Supply Current | I _L | - | 48 | - | mA | (3) |
| Power Consumption | P _L | - | 1.478 | 1.584 | W | |
| LED Life Time | L _{BL} | 12000 | - | - | Hrs | (4) |

Note (1) LED current is measured by utilizing a high frequency current meter as shown below :

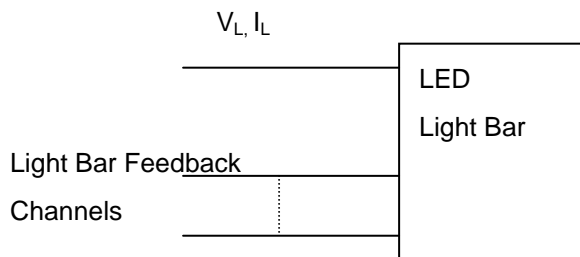

Note (2) For better LED light bar driving quality, it is recommended to utilize the adaptive boost converter with current balancing function to drive LED light-bar.

Note (3) $P_L = I_L \times V_L$ (Without LED converter transfer efficiency)

Note (4) The lifetime of LED is defined as the time when it continues to operate under the conditions at Ta = 25 ± 2 °C and I_L = 16 mA(Per EA) until the brightness becomes ≤ 50% of its original value.

4.4 INPUT SIGNAL TIMING SPECIFICATIONS

4.4.1 DISPLAY PORT INTERFACE

| Parameter | Symbol | Min. | Typ. | Max. | Unit | Notes |
|---|------------------|------|------|-------|------|--------|
| Differential Signal Common Mode Voltage(MainLink and AUX) | VCM | (0) | | (2) | V | (1)(3) |
| AUX AC Coupling Capacitor | C _{AUX} | (75) | | (200) | nF | (2) |

Note (1) Display port interface related AC coupled signals are following VESA DisplayPort Standard Version1. Revision 1a and VESA Embedded DisplayPort™ Standard Version 1.1.

(2) The AUX AC Coupling Capacitor placed on Source Devices.

(3) DisplayPortCompliance Test Specification (CTS) 1.1

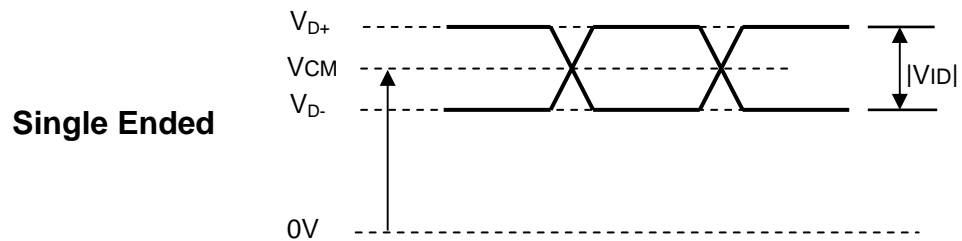

4.4.2 COLOR DATA INPUT ASSIGNMENT

The brightness of each primary color (red, green and blue) is based on the 6-bit gray scale data input for the color. The higher the binary input the brighter the color. The table below provides the assignment of color versus data input.

| Color | | Data Signal | | | | | | | | | | | | | | | | | |
|---------------------|---------------|-------------|----|----|----|----|----|-------|----|----|----|----|----|------|----|----|----|----|----|
| | | Red | | | | | | Green | | | | | | Blue | | | | | |
| | | R5 | R4 | R3 | R2 | R1 | R0 | G5 | G4 | G3 | G2 | G1 | G0 | B5 | B4 | B3 | B2 | B1 | B0 |
| Basic Colors | Black | 0 | 0 | 0 | 0 | 0 | 0 | 0 | 0 | 0 | 0 | 0 | 0 | 0 | 0 | 0 | 0 | 0 | 0 |
| | Red | 1 | 1 | 1 | 1 | 1 | 1 | 0 | 0 | 0 | 0 | 0 | 0 | 0 | 0 | 0 | 0 | 0 | 0 |
| | Green | 0 | 0 | 0 | 0 | 0 | 0 | 1 | 1 | 1 | 1 | 1 | 1 | 0 | 0 | 0 | 0 | 0 | 0 |
| | Blue | 0 | 0 | 0 | 0 | 0 | 0 | 0 | 0 | 0 | 0 | 0 | 0 | 1 | 1 | 1 | 1 | 1 | 1 |
| | Cyan | 0 | 0 | 0 | 0 | 0 | 0 | 1 | 1 | 1 | 1 | 1 | 1 | 1 | 1 | 1 | 1 | 1 | 1 |
| | Magenta | 1 | 1 | 1 | 1 | 1 | 1 | 0 | 0 | 0 | 0 | 0 | 0 | 1 | 1 | 1 | 1 | 1 | 1 |
| | Yellow | 1 | 1 | 1 | 1 | 1 | 1 | 1 | 1 | 1 | 1 | 1 | 1 | 0 | 0 | 0 | 0 | 0 | 0 |
| | White | 1 | 1 | 1 | 1 | 1 | 1 | 1 | 1 | 1 | 1 | 1 | 1 | 1 | 1 | 1 | 1 | 1 | 1 |
| Gray Scale Of Red | Red(0)/Dark | 0 | 0 | 0 | 0 | 0 | 0 | 0 | 0 | 0 | 0 | 0 | 0 | 0 | 0 | 0 | 0 | 0 | |
| | Red(1) | 0 | 0 | 0 | 0 | 0 | 1 | 0 | 0 | 0 | 0 | 0 | 0 | 0 | 0 | 0 | 0 | 0 | |
| | Red(2) | 0 | 0 | 0 | 0 | 1 | 0 | 0 | 0 | 0 | 0 | 0 | 0 | 0 | 0 | 0 | 0 | 0 | |
| | : | : | : | : | : | : | : | : | : | : | : | : | : | : | : | : | : | : | |
| | : | : | : | : | : | : | : | : | : | : | : | : | : | : | : | : | : | : | |
| | Red(61) | 1 | 1 | 1 | 1 | 0 | 1 | 0 | 0 | 0 | 0 | 0 | 0 | 0 | 0 | 0 | 0 | 0 | |
| | Red(62) | 1 | 1 | 1 | 1 | 1 | 0 | 0 | 0 | 0 | 0 | 0 | 0 | 0 | 0 | 0 | 0 | 0 | |
| | Red(63) | 1 | 1 | 1 | 1 | 1 | 1 | 0 | 0 | 0 | 0 | 0 | 0 | 0 | 0 | 0 | 0 | 0 | |
| Gray Scale Of Green | Green(0)/Dark | 0 | 0 | 0 | 0 | 0 | 0 | 0 | 0 | 0 | 0 | 0 | 0 | 0 | 0 | 0 | 0 | 0 | |
| | Green(1) | 0 | 0 | 0 | 0 | 0 | 0 | 0 | 0 | 0 | 0 | 0 | 1 | 0 | 0 | 0 | 0 | 0 | |
| | Green(2) | 0 | 0 | 0 | 0 | 0 | 0 | 0 | 0 | 0 | 0 | 1 | 0 | 0 | 0 | 0 | 0 | 0 | |
| | : | : | : | : | : | : | : | : | : | : | : | : | : | : | : | : | : | : | |
| | : | : | : | : | : | : | : | : | : | : | : | : | : | : | : | : | : | : | |
| | Green(61) | 0 | 0 | 0 | 0 | 0 | 0 | 1 | 1 | 1 | 1 | 0 | 1 | 0 | 0 | 0 | 0 | 0 | |
| | Green(62) | 0 | 0 | 0 | 0 | 0 | 0 | 1 | 1 | 1 | 1 | 1 | 0 | 0 | 0 | 0 | 0 | 0 | |
| | Green(63) | 0 | 0 | 0 | 0 | 0 | 0 | 1 | 1 | 1 | 1 | 1 | 1 | 0 | 0 | 0 | 0 | 0 | |
| Gray Scale Of Blue | Blue(0)/Dark | 0 | 0 | 0 | 0 | 0 | 0 | 0 | 0 | 0 | 0 | 0 | 0 | 0 | 0 | 0 | 0 | 0 | |
| | Blue(1) | 0 | 0 | 0 | 0 | 0 | 0 | 0 | 0 | 0 | 0 | 0 | 0 | 0 | 0 | 0 | 0 | 1 | |
| | Blue(2) | 0 | 0 | 0 | 0 | 0 | 0 | 0 | 0 | 0 | 0 | 0 | 0 | 0 | 0 | 0 | 0 | 1 | |
| | : | : | : | : | : | : | : | : | : | : | : | : | : | : | : | : | : | : | |
| | : | : | : | : | : | : | : | : | : | : | : | : | : | : | : | : | : | : | |
| | Blue(61) | 0 | 0 | 0 | 0 | 0 | 0 | 0 | 0 | 0 | 0 | 0 | 0 | 1 | 1 | 1 | 1 | 0 | |
| | Blue(62) | 0 | 0 | 0 | 0 | 0 | 0 | 0 | 0 | 0 | 0 | 0 | 0 | 1 | 1 | 1 | 1 | 0 | |
| | Blue(63) | 0 | 0 | 0 | 0 | 0 | 0 | 0 | 0 | 0 | 0 | 0 | 0 | 1 | 1 | 1 | 1 | 1 | |

Note (1) 0: Low Level Voltage, 1: High Level Voltage

4.5 DISPLAY TIMING SPECIFICATIONS

The input signal timing specifications are shown as the following table and timing diagram.

Refresh rate 60Hz

| Signal | Item | Symbol | Min. | Typ. | Max. | Unit | Note |
|--------|-----------------------------------|--------|--------|---------|---------|------|------|
| DCLK | Frequency | 1/Tc | (67.9) | (75.45) | (79.22) | MHz | - |
| DE | Vertical Total Time | TV | (790) | (806) | (830) | TH | - |
| | Vertical Active Display Period | TVD | (768) | (768) | (768) | TH | - |
| | Vertical Active Blanking Period | TVB | TV-TVD | (38) | TV-TVD | TH | - |
| | Horizontal Total Time | TH | (1482) | (1560) | (1716) | Tc | - |
| | Horizontal Active Display Period | THD | (1366) | (1366) | (1366) | Tc | - |
| | Horizontal Active Blanking Period | THB | TH-THB | (194) | TH-THB | Tc | - |

INPUT SIGNAL TIMING DIAGRAM

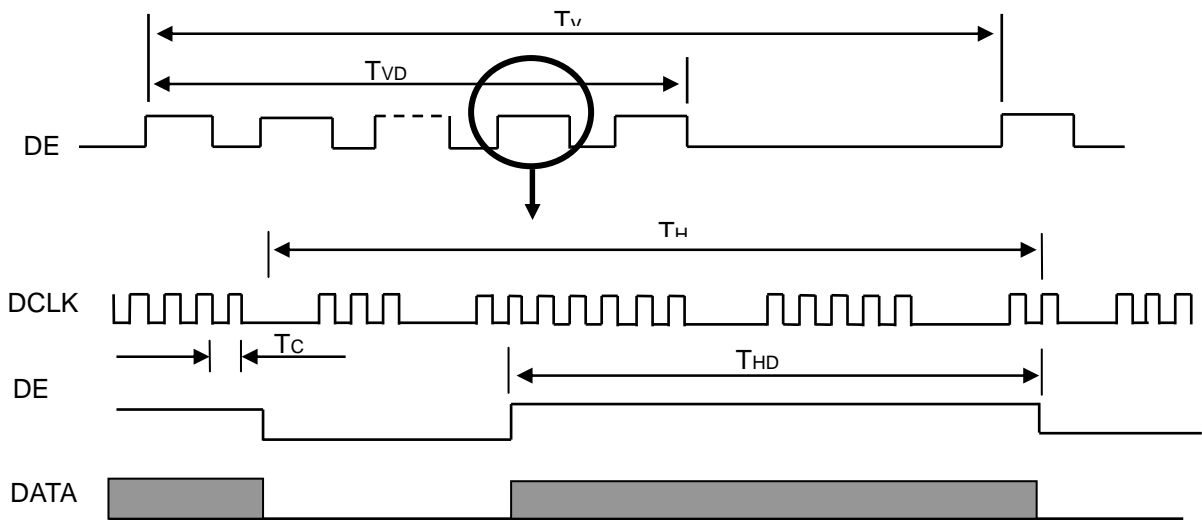

4.6 POWER ON/OFF SEQUENCE

The power sequence specifications are shown as the following table and diagram.

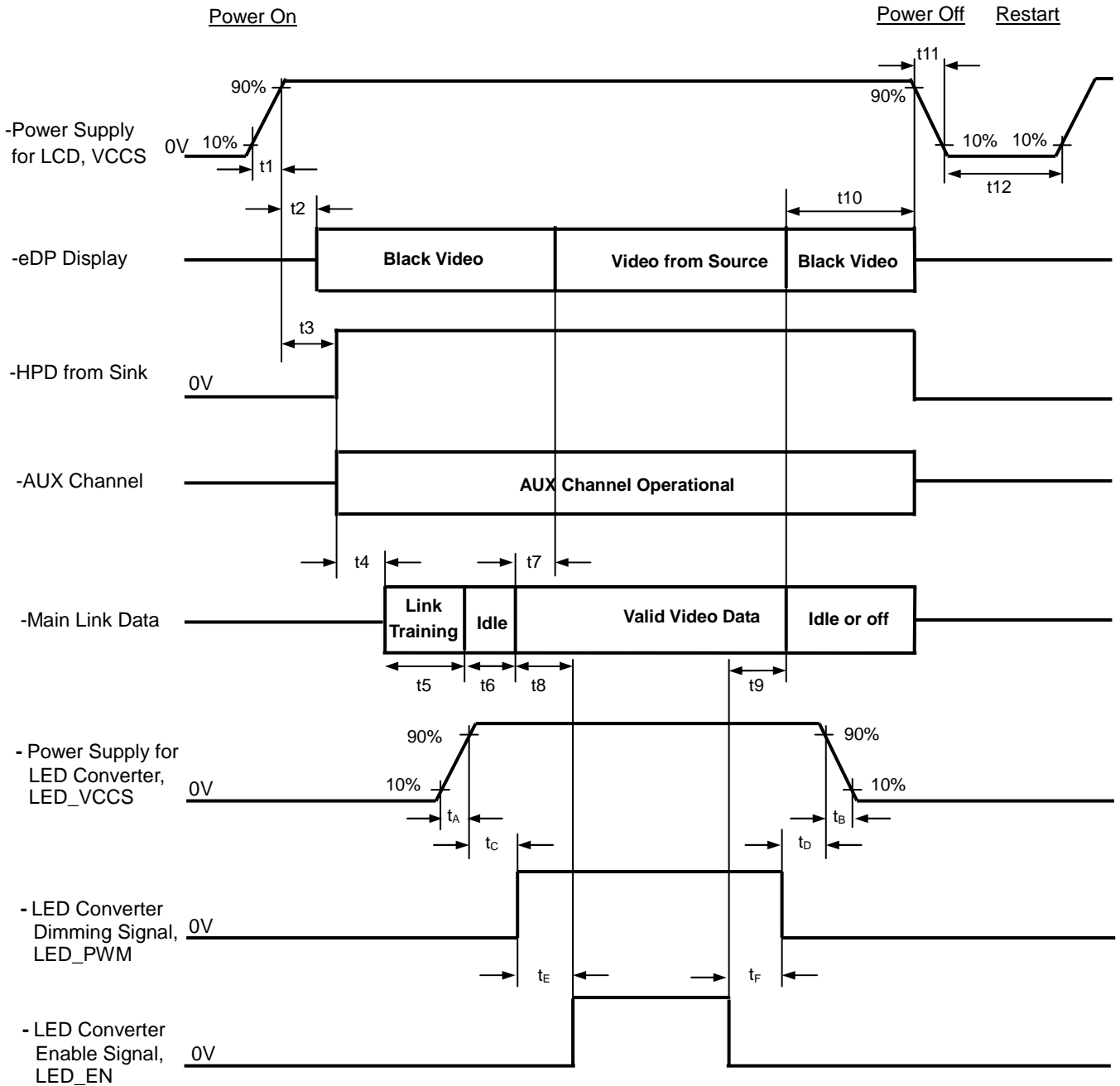

Timing Specifications:

| Parameter | Description | Reqd. By | Value | | Unit | Notes |
|----------------|---|----------|-------|-------|------|--|
| | | | Min | Max | | |
| t1 | Power rail rise time, 10% to 90% | Source | (0.5) | (10) | ms | |
| t2 | Delay from LCD,VCCS to black video generation | Sink | (0) | (200) | ms | Prevents display noise until valid video data is received from the Source |
| t3 | Delay from LCD,VCCS to HPD high | Sink | (0) | (200) | ms | Sink Aux Channel must be operational upon HPD high |
| t4 | Delay from HPD high to link training initialization | Source | - | - | ms | Allows for Source to read Link capability and initialize |
| t5 | Link training duration | Source | - | - | ms | Dependant on Source link training protocol |
| t6 | Link idle | Source | - | - | ms | Min accounts for required BS-Idle pattern. Max allows for Source frame synchronization |
| t7 | Delay from valid video data from Source to video on display | Sink | (0) | (50) | ms | Max allows Sink validate video data and timing |
| t8 | Delay from valid video data from Source to backlight on | Source | - | - | ms | Source must assure display video is stable |
| t9 | Delay from backlight off to end of valid video data | Source | - | - | ms | Source must assure backlight is no longer illuminated |
| t10 | Delay from end of valid video data from Source to power off | Source | (0) | (500) | ms | - |
| t11 | VCCS power rail fall time, 90% to 10% | Source | (0.5) | (10) | ms | - |
| t12 | VCCS Power off time | Source | (500) | - | ms | - |
| t _A | LED power rail rise time, 10% to 90% | Source | (0.5) | (10) | ms | - |
| t _B | LED power rail fall time, 90% to 10% | Source | (0) | (10) | ms | - |
| t _C | Delay from LED power rising to LED dimming signal | Source | (1) | - | ms | - |
| t _D | Delay from LED dimming signal to LED power falling | Source | (1) | - | ms | - |
| t _E | Delay from LED dimming signal to LED enable signal | Source | (1) | - | ms | - |
| t _F | Delay from LED enable signal to LED dimming signal | Source | (1) | - | ms | - |

Note (1) Please don't plug or unplug the interface cable when system is turned on.

Note (2) Please avoid floating state of the interface signal during signal invalid period.

Note (3) It is recommended that the backlight power must be turned on after the power supply for LCD and the interface signal is valid.

5. OPTICAL CHARACTERISTICS

5.1 TEST CONDITIONS

| Item | Symbol | Value | Unit |
|-----------------------------|---|-------|------|
| Ambient Temperature | Ta | 25±2 | °C |
| Ambient Humidity | Ha | 50±10 | %RH |
| Supply Voltage | V _{CC} | 3.3 | V |
| Input Signal | According to typical value in "3. ELECTRICAL CHARACTERISTICS" | | |
| LED Light Bar Input Current | I _L | 48 | mA |

The measurement methods of optical characteristics are shown in Section 5.2. The following items should be measured under the test conditions described in Section 5.1 and stable environment shown in Note (5).

5.2 OPTICAL SPECIFICATIONS

| Item | | Symbol | Condition | Min. | Typ. | Max. | Unit | Note | |
|-----------------------------|------------|------------------|--|--|---------------|-------|-------------------|-----------------|---------|
| Contrast Ratio | | CR | $\theta_x=0^\circ, \theta_y=0^\circ$ Viewing Normal Angle | 250 | 400 | - | - | (2), (5),(7) | |
| Response Time | | T _R | | - | 3 | 8 | ms | (3),(7) | |
| | | T _F | | - | 8 | 13 | ms | | |
| Average Luminance of White | | L _{Ave} | | 170 | 200 | - | cd/m ² | (4), (6),(7) | |
| Color Chromaticity | Red | R _x | | $\theta_x=0^\circ, \theta_y=0^\circ$ Viewing Normal Angle | Typ - 0.03 | 0.585 | Typ + 0.03 | - | (1),(7) |
| | | R _y | | | | 0.354 | | - | |
| | Green | G _x | | | | 0.338 | | - | |
| | | G _y | | | | 0.575 | | - | |
| | Blue | B _x | | | | 0.152 | | - | |
| | | B _y | | | | 0.118 | | - | |
| | White | W _x | 0.313 | | | - | | | |
| | | W _y | 0.329 | | | - | | | |
| Viewing Angle | Horizontal | θ_{x+} | CR≥10 | 40 | 45 | - | Deg. | (1),(5), (7) | |
| | | θ_{x-} | | 40 | 45 | - | | | |
| | Vertical | θ_{y+} | | 15 | 20 | - | | | |
| | | θ_{y-} | | 40 | 45 | - | | | |
| White Variation of 5 Points | | δW_{5p} | $\theta_x=0^\circ, \theta_y=0^\circ$ | 80 | -- | -- | %- | (5),(6), (7) | |

Note (1) Definition of Viewing Angle (θ_x, θ_y):

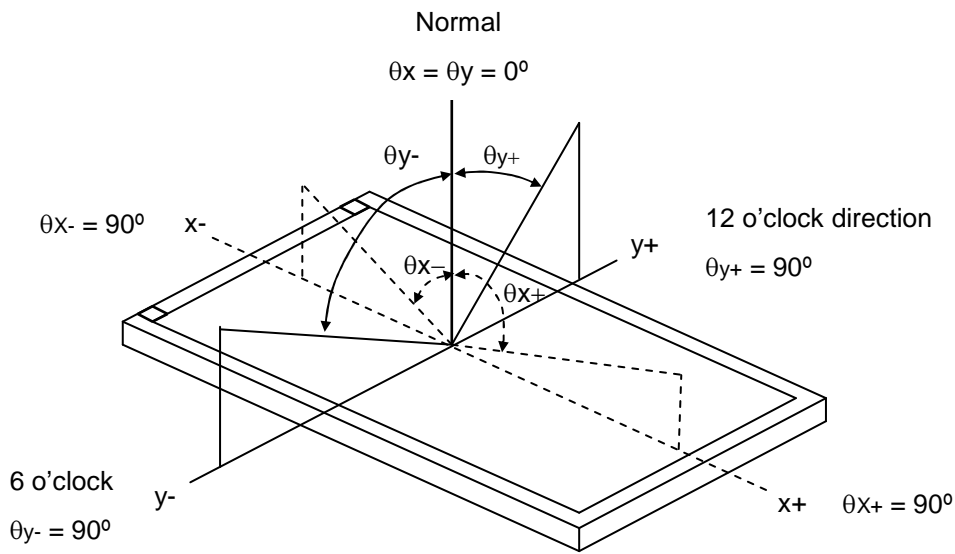

Note (2) Definition of Contrast Ratio (CR):

The contrast ratio can be calculated by the following expression.

$$\text{Contrast Ratio (CR)} = L_{63} / L_0$$

L63: Luminance of gray level 63

L 0: Luminance of gray level 0

$$\text{CR} = \text{CR} (1)$$

CR (X) is corresponding to the Contrast Ratio of the point X at Figure in Note (6).

Note (3) Definition of Response Time (T_R , T_F):

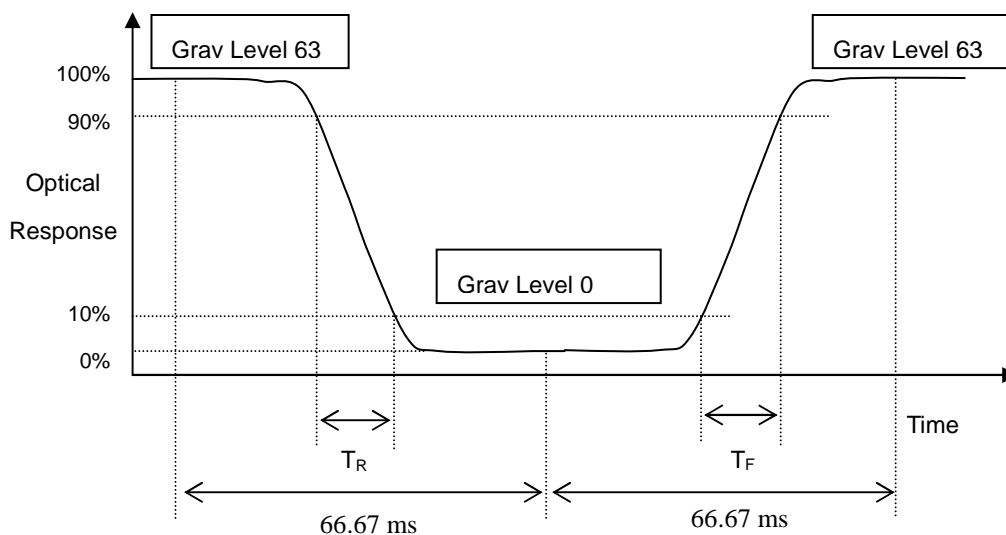

Note (4) Definition of Average Luminance of White (L_{AVE}):

Measure the luminance of White at 5 points

$$L_{AVE} = [L (1)+ L (2)+ L (3)+ L (4)+ L (5)] / 5$$

L (x) is corresponding to the luminance of the point X at Figure in Note (6)

Note (5) Measurement Setup:

The LCD module should be stabilized at given temperature for 20 minutes to avoid abrupt temperature change during measuring. In order to stabilize the luminance, the measurement should be executed after lighting Backlight for 20 minutes in a windless room.

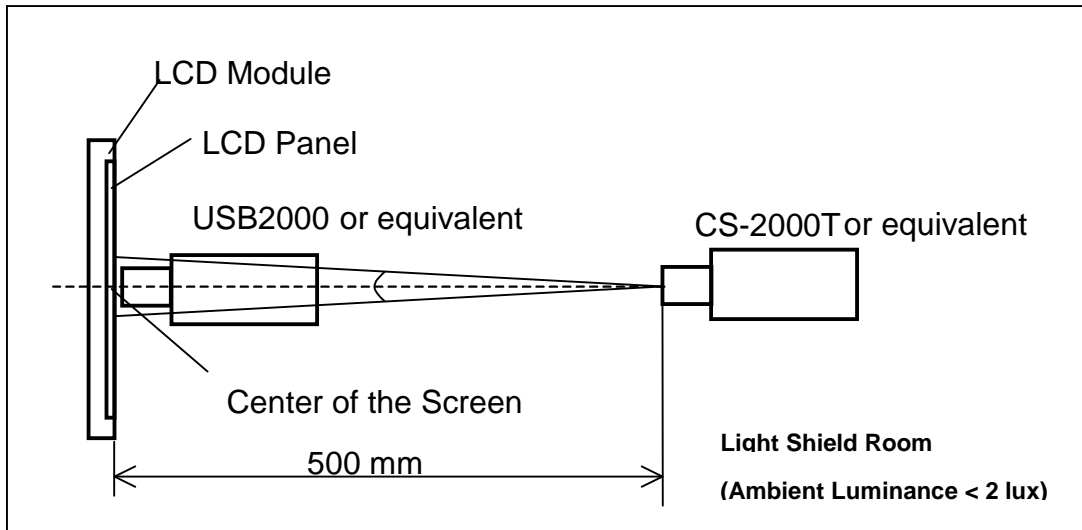

Note (6) Definition of White Variation (δW):

Measure the luminance of White at 5 points

$$\delta W_{5p} = \{ \text{Minimum [L (1)~ L (5)]} / \text{Maximum [L (1)~ L (5)]} \} * 100\%$$

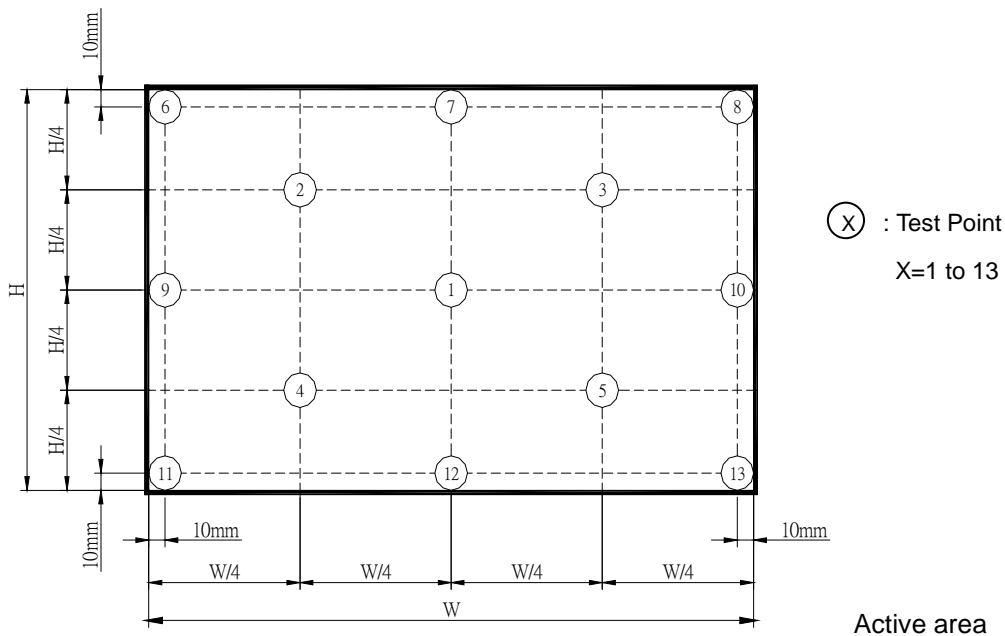

Note (7) The listed optical specifications refer to the initial value of manufacture, but the condition of the specifications after long-term operation will not be warranted.

6. RELIABILITY TEST ITEM

| Test Item | Test Condition | Note |
|---|---|---------|
| High Temperature Storage Test | 60°C, 240 hours | (1) (2) |
| Low Temperature Storage Test | -20°C, 240 hours | |
| Thermal Shock Storage Test | -20°C, 0.5hour \longleftrightarrow 60°C, 0.5hour; 100cycles, 1hour/cycle | |
| High Temperature Operation Test | 50°C, 240 hours | |
| Low Temperature Operation Test | 0°C, 240 hours | |
| High Temperature & High Humidity Operation Test | 50°C, 80% RH, 240 hours | |
| ESD Test (Operation) | 150pF, 330 Ω , 1sec/cycle Condition 1 : Contact Discharge, \pm 8KV Condition 2 : Air Discharge, \pm 15KV | (1) |
| Shock (Non-Operating) | 220G, 2ms, half sine wave, 1 time for each direction of \pm X, \pm Y, \pm Z | (1)(3) |
| Vibration (Non-Operating) | 1.5G / 10-500 Hz, Sine wave, 30 min/cycle, 1cycle for each X, Y, Z | (1)(3) |

Note (1) criteria : Normal display image with no obvious non-uniformity and no line defect.

Note (2) Evaluation should be tested after storage at room temperature for more than two hour

Note (3) At testing Vibration and Shock, the fixture in holding the module has to be hard and rigid enough so that the module would not be twisted or bent by the fixture.

7. PACKING

7.1 MODULE LABEL

The barcode nameplate is pasted on each module as illustration, and its definitions are as following explanation.



- (a) Model Name: N156BGE – E31
- (b) Revision: Rev. XX, for example: C1, C2 ...etc.
- (c) Serial ID: X X X X X X Y M D L N N N N
 - Serial No.
 - Product Line
 - Year, Month, Date
 - INNOLUX Internal Use
 - Revision
 - INNOLUX Internal Use
- (d) Production Location: MADE IN XXXX. XXXX stands for production location.
- (e) UL Logo : XXXX is UL factory ID.

7.2 CARTON

Box Dimensions : 500(L)*370(W)*270(H)
Weight : Approx. 11.36Kg (20 module .per. 1box)

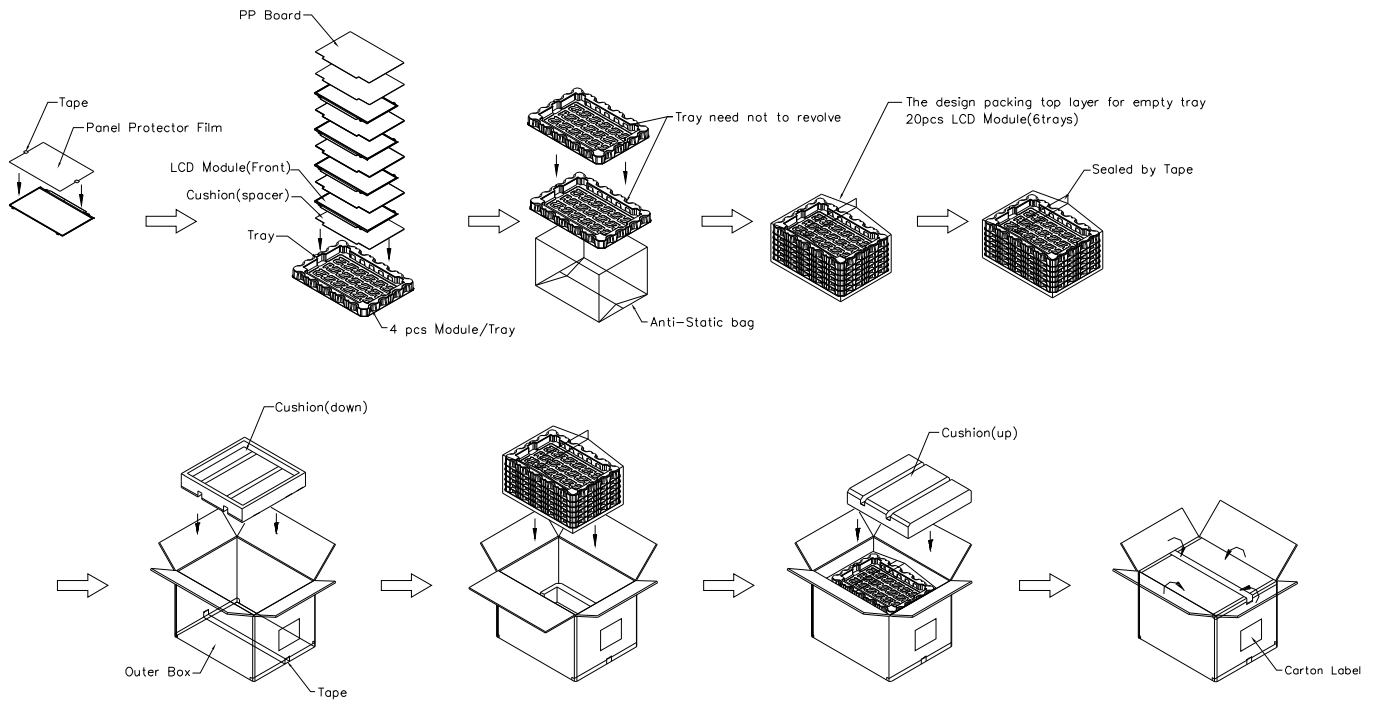

Figure. 7-2 Packing method

7.3 PALLET

Sea & Land Transportation

Air Transportation

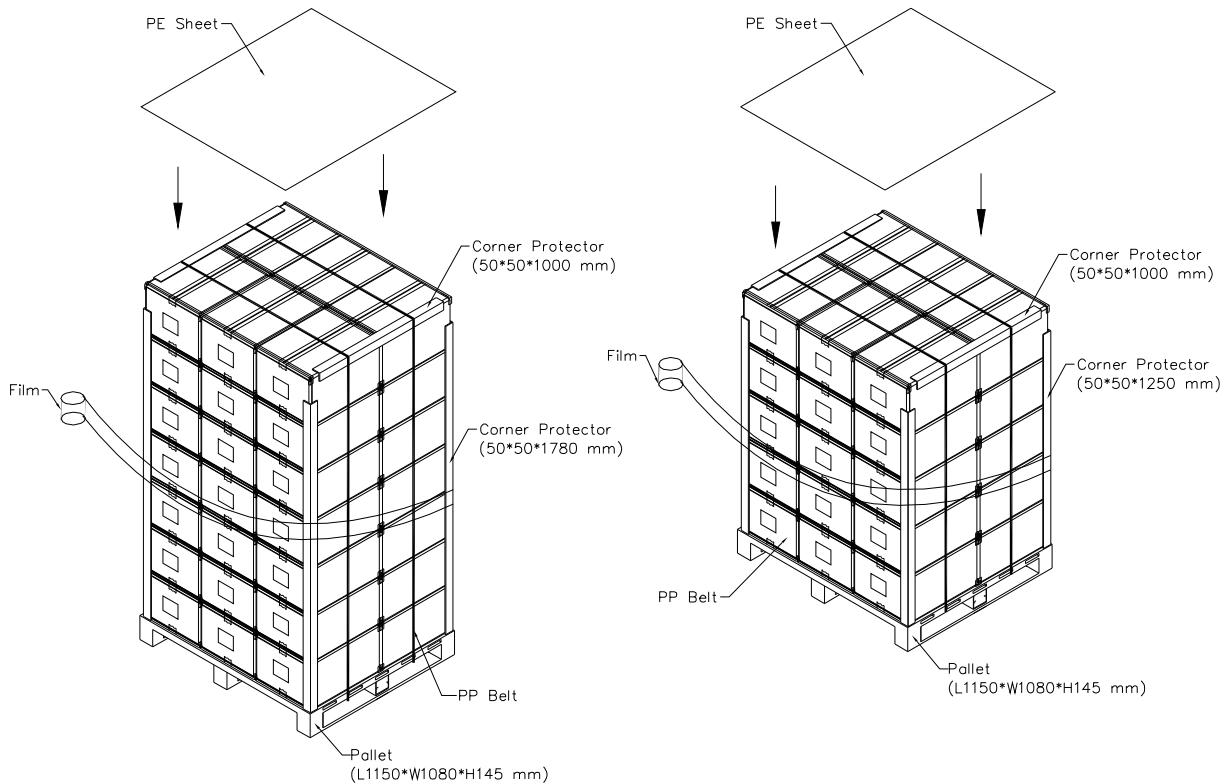

Figure. 7-3 Packing method

8. PRECAUTIONS

8.1 HANDLING PRECAUTIONS

- (1) The module should be assembled into the system firmly by using every mounting hole. Be careful not to twist or bend the module.
- (2) While assembling or installing modules, it can only be in the clean area. The dust and oil may cause electrical short or damage the polarizer.
- (3) Use fingerstalls or soft gloves in order to keep display clean during the incoming inspection and assembly process.
- (4) Do not press or scratch the surface harder than a HB pencil lead on the panel because the polarizer is very soft and easily scratched.
- (5) If the surface of the polarizer is dirty, please clean it by some absorbent cotton or soft cloth. Do not use Ketone type materials (ex. Acetone), Ethyl alcohol, Toluene, Ethyl acid or Methyl chloride. It might permanently damage the polarizer due to chemical reaction.
- (6) Wipe off water droplets or oil immediately. Staining and discoloration may occur if they left on panel for a long time.
- (7) If the liquid crystal material leaks from the panel, it should be kept away from the eyes or mouth. In case of contacting with hands, legs or clothes, it must be washed away thoroughly with soap.
- (8) Protect the module from static electricity, it may cause damage to the C-MOS Gate Array IC.
- (9) Do not disassemble the module.
- (10) Do not pull or fold the LED wire.
- (11) Pins of I/F connector should not be touched directly with bare hands.

8.2 STORAGE PRECAUTIONS

- (1) High temperature or humidity may reduce the performance of module. Please store LCD module within the specified storage conditions.
- (2) It is dangerous that moisture come into or contacted the LCD module, because the moisture may damage LCD module when it is operating.
- (3) It may reduce the display quality if the ambient temperature is lower than 10 °C. For example, the response time will become slowly, and the starting voltage of LED will be higher than the room temperature.

8.3 OPERATION PRECAUTIONS

- (1) Do not pull the I/F connector in or out while the module is operating.
- (2) Always follow the correct power on/off sequence when LCD module is connecting and operating. This can prevent the CMOS LSI chips from damage during latch-up.
- (3) The startup voltage of Backlight is approximately 1000 Volts. It may cause electrical shock while assembling with converter. Do not disassemble the module or insert anything into the Backlight unit.

Appendix. EDID DATA STRUCTURE

The EDID (Extended Display Identification Data) data formats are to support displays as defined in the VESA Plug & Display and FPD standards.

| Byte # (decimal) | Byte # (hex) | Field Name and Comments | Value (hex) | Value (binary) |
|---------------------|-----------------|--|----------------|-------------------|
| 0 | 0 | Header | 00 | 00000000 |
| 1 | 1 | Header | FF | 11111111 |
| 2 | 2 | Header | FF | 11111111 |
| 3 | 3 | Header | FF | 11111111 |
| 4 | 4 | Header | FF | 11111111 |
| 5 | 5 | Header | FF | 11111111 |
| 6 | 6 | Header | FF | 11111111 |
| 7 | 7 | Header | 00 | 00000000 |
| 8 | 8 | EISA ID manufacturer name ("CMN") | 0D | 00001101 |
| 9 | 9 | EISA ID manufacturer name (Compressed ASCII) | AE | 10101110 |
| 10 | 0A | ID product code (N156BGE-E31) | BE | 10111110 |
| 11 | 0B | ID product code (hex LSB first; N156BGE-E31) | 15 | 00010101 |
| 12 | 0C | ID S/N (fixed "0") | 00 | 00000000 |
| 13 | 0D | ID S/N (fixed "0") | 00 | 00000000 |
| 14 | 0E | ID S/N (fixed "0") | 00 | 00000000 |
| 15 | 0F | ID S/N (fixed "0") | 00 | 00000000 |
| 16 | 10 | Week of manufacture (fixed week code) | 2C | 00101100 |
| 17 | 11 | Year of manufacture (fixed year code) | 16 | 00010110 |
| 18 | 12 | EDID structure version # ("1") | 01 | 00000001 |
| 19 | 13 | EDID revision # ("4") | 04 | 00000100 |
| 20 | 14 | Video I/P definition ("digital") | 95 | 10010101 |
| 21 | 15 | Max H image size ("34.42cm") | 22 | 00100010 |
| 22 | 16 | Max V image size ("19.35cm") | 13 | 00010011 |
| 23 | 17 | Display Gamma (Gamma = "2.2") | 78 | 01111000 |
| 24 | 18 | Feature support ("Active off, RGB Color") | 02 | 00000010 |
| 25 | 19 | Rx1, Rx0, Ry1, Ry0, Gx1, Gx0, Gy1, Gy0 | E9 | 11101001 |
| 26 | 1A | Bx1, Bx0, By1, By0, Wx1, Wx0, Wy1, Wy0 | 15 | 00010101 |
| 27 | 1B | Rx=0.585 | 95 | 10010101 |
| 28 | 1C | Ry=0.354 | 5A | 01011010 |
| 29 | 1D | Gx=0.338 | 56 | 01010110 |
| 30 | 1E | Gy=0.575 | 93 | 10010011 |
| 31 | 1F | Bx=0.152 | 27 | 00100111 |
| 32 | 20 | By=0.118 | 1E | 00011110 |
| 33 | 21 | Wx=0.313 | 50 | 01010000 |
| 34 | 22 | Wy=0.329 | 54 | 01010100 |
| 35 | 23 | Established timings 1 | 00 | 00000000 |
| 36 | 24 | Established timings 2 | 00 | 00000000 |
| 37 | 25 | Manufacturer's reserved timings | 00 | 00000000 |
| 38 | 26 | Standard timing ID # 1 | 01 | 00000001 |
| 39 | 27 | Standard timing ID # 1 | 01 | 00000001 |
| 40 | 28 | Standard timing ID # 2 | 01 | 00000001 |
| 41 | 29 | Standard timing ID # 2 | 01 | 00000001 |

| | | | | |
|----|----|---|----|----------|
| 42 | 2A | Standard timing ID # 3 | 01 | 00000001 |
| 43 | 2B | Standard timing ID # 3 | 01 | 00000001 |
| 44 | 2C | Standard timing ID # 4 | 01 | 00000001 |
| 45 | 2D | Standard timing ID # 4 | 01 | 00000001 |
| 46 | 2E | Standard timing ID # 5 | 01 | 00000001 |
| 47 | 2F | Standard timing ID # 5 | 01 | 00000001 |
| 48 | 30 | Standard timing ID # 6 | 01 | 00000001 |
| 49 | 31 | Standard timing ID # 6 | 01 | 00000001 |
| 50 | 32 | Standard timing ID # 7 | 01 | 00000001 |
| 51 | 33 | Standard timing ID # 7 | 01 | 00000001 |
| 52 | 34 | Standard timing ID # 8 | 01 | 00000001 |
| 53 | 35 | Standard timing ID # 8 | 01 | 00000001 |
| 54 | 36 | Detailed timing description # 1 Pixel clock ("75.45MHz", According to VESA CVT Rev1.1) | 79 | 01111001 |
| 55 | 37 | # 1 Pixel clock (hex LSB first) | 1D | 00011101 |
| 56 | 38 | # 1 H active ("1366") | 56 | 01010110 |
| 57 | 39 | # 1 H blank ("194") | C2 | 11000010 |
| 58 | 3A | # 1 H active : H blank ("1366 : 194") | 50 | 01010000 |
| 59 | 3B | # 1 V active ("768") | 00 | 00000000 |
| 60 | 3C | # 1 V blank ("38") | 26 | 00100110 |
| 61 | 3D | # 1 V active : V blank ("768 :38") | 30 | 00110000 |
| 62 | 3E | # 1 H sync offset ("31") | 1F | 00011111 |
| 63 | 3F | # 1 H sync pulse width ("65") | 41 | 01000001 |
| 64 | 40 | # 1 V sync offset : V sync pulse width ("4 : 12") | 4C | 01001100 |
| 65 | 41 | # 1 H sync offset : H sync pulse width : V sync offset : V sync width ("31: 65 : 4 : 12") | 00 | 00000000 |
| 66 | 42 | # 1 H image size ("344 mm") | 58 | 01011000 |
| 67 | 43 | # 1 V image size ("194 mm") | C2 | 11000010 |
| 68 | 44 | # 1 H image size : V image size ("344 : 194") | 10 | 00010000 |
| 69 | 45 | # 1 H boarder ("0") | 00 | 00000000 |
| 70 | 46 | # 1 V boarder ("0") | 00 | 00000000 |
| 71 | 47 | # 1 Non-interlaced, Normal, no stereo, Separate sync, H/V pol Negatives | 18 | 00011000 |
| 72 | 48 | Detailed timing description # 2 | 00 | 00000000 |
| 73 | 49 | # 2 Flag | 00 | 00000000 |
| 74 | 4A | # 2 Reserved | 00 | 00000000 |
| 75 | 4B | # 2 FE (hex) defines ASCII string (Model Name "N156BGE-E31", ASCII) | FE | 11111110 |
| 76 | 4C | # 2 Flag | 00 | 00000000 |
| 77 | 4D | # 2 1st character of name ("N") | 4E | 01001110 |
| 78 | 4E | # 2 2nd character of name ("1") | 31 | 00110001 |
| 79 | 4F | # 2 3rd character of name ("5") | 35 | 00110101 |
| 80 | 50 | # 2 4th character of name ("6") | 36 | 00110110 |
| 81 | 51 | # 2 5th character of name ("B") | 42 | 01000010 |
| 82 | 52 | # 2 6th character of name ("G") | 47 | 01000111 |
| 83 | 53 | # 2 7th character of name ("E") | 45 | 01000101 |
| 84 | 54 | # 2 8th character of name ("-") | 2D | 00101101 |
| 85 | 55 | # 2 9th character of name ("E") | 45 | 01000101 |

| | | | | |
|-----|----|--|----|----------|
| 86 | 56 | # 2 10th character of name ("3") | 33 | 00110011 |
| 87 | 57 | # 2 11th character of name ("1") | 31 | 00110001 |
| 88 | 58 | # 2 New line character indicates end of ASCII string | 0A | 00001010 |
| 89 | 59 | # 2 Padding with "Blank" character | 20 | 00100000 |
| 90 | 5A | Detailed timing description # 3 | 00 | 00000000 |
| 91 | 5B | # 3 Flag | 00 | 00000000 |
| 92 | 5C | # 3 Reserved | 00 | 00000000 |
| 93 | 5D | # 3 FE (hex) defines ASCII string (Vendor "CMN", ASCII) | FE | 11111110 |
| 94 | 5E | # 3 Flag | 00 | 00000000 |
| 95 | 5F | # 3 1st character of string ("C") | 43 | 01000011 |
| 96 | 60 | # 3 2nd character of string ("M") | 4D | 01001101 |
| 97 | 61 | # 3 3rd character of string ("N") | 4E | 01001110 |
| 98 | 62 | # 3 New line character indicates end of ASCII string | 0A | 00001010 |
| 99 | 63 | # 3 Padding with "Blank" character | 20 | 00100000 |
| 100 | 64 | # 3 Padding with "Blank" character | 20 | 00100000 |
| 101 | 65 | # 3 Padding with "Blank" character | 20 | 00100000 |
| 102 | 66 | # 3 Padding with "Blank" character | 20 | 00100000 |
| 103 | 67 | # 3 Padding with "Blank" character | 20 | 00100000 |
| 104 | 68 | # 3 Padding with "Blank" character | 20 | 00100000 |
| 105 | 69 | # 3 Padding with "Blank" character | 20 | 00100000 |
| 106 | 6A | # 3 Padding with "Blank" character | 20 | 00100000 |
| 107 | 6B | # 3 Padding with "Blank" character | 20 | 00100000 |
| 108 | 6C | Detailed timing description # 4 | 00 | 00000000 |
| 109 | 6D | # 4 Flag | 00 | 00000000 |
| 110 | 6E | # 4 Reserved | 00 | 00000000 |
| 111 | 6F | # 4 FE (hex) defines ASCII string (Model Name"N156BGE-E31", ASCII) | FE | 11111110 |
| 112 | 70 | # 4 Flag | 00 | 00000000 |
| 113 | 71 | # 4 1st character of name ("N") | 4E | 01001110 |
| 114 | 72 | # 4 2nd character of name ("1") | 31 | 00110001 |
| 115 | 73 | # 4 3rd character of name ("5") | 35 | 00110101 |
| 116 | 74 | # 4 4th character of name ("6") | 36 | 00110110 |
| 117 | 75 | # 4 5th character of name ("B") | 42 | 01000010 |
| 118 | 76 | # 4 6th character of name ("G") | 47 | 01000111 |
| 119 | 77 | # 4 7th character of name ("E") | 45 | 01000101 |
| 120 | 78 | # 4 8th character of name ("-") | 2D | 00101101 |
| 121 | 79 | # 4 9th character of name ("E") | 45 | 01000101 |
| 122 | 7A | # 4 10th character of name ("3") | 33 | 00110011 |
| 123 | 7B | # 4 11th character of name ("1") | 31 | 00110001 |
| 124 | 7C | # 4 New line character indicates end of ASCII string | 0A | 00001010 |
| 125 | 7D | # 4 Padding with "Blank" character | 20 | 00100000 |
| 126 | 7E | Extension flag | 00 | 00000000 |
| 127 | 7F | Checksum | 6A | 01101010 |

Appendix. OUTLINE DRAWING

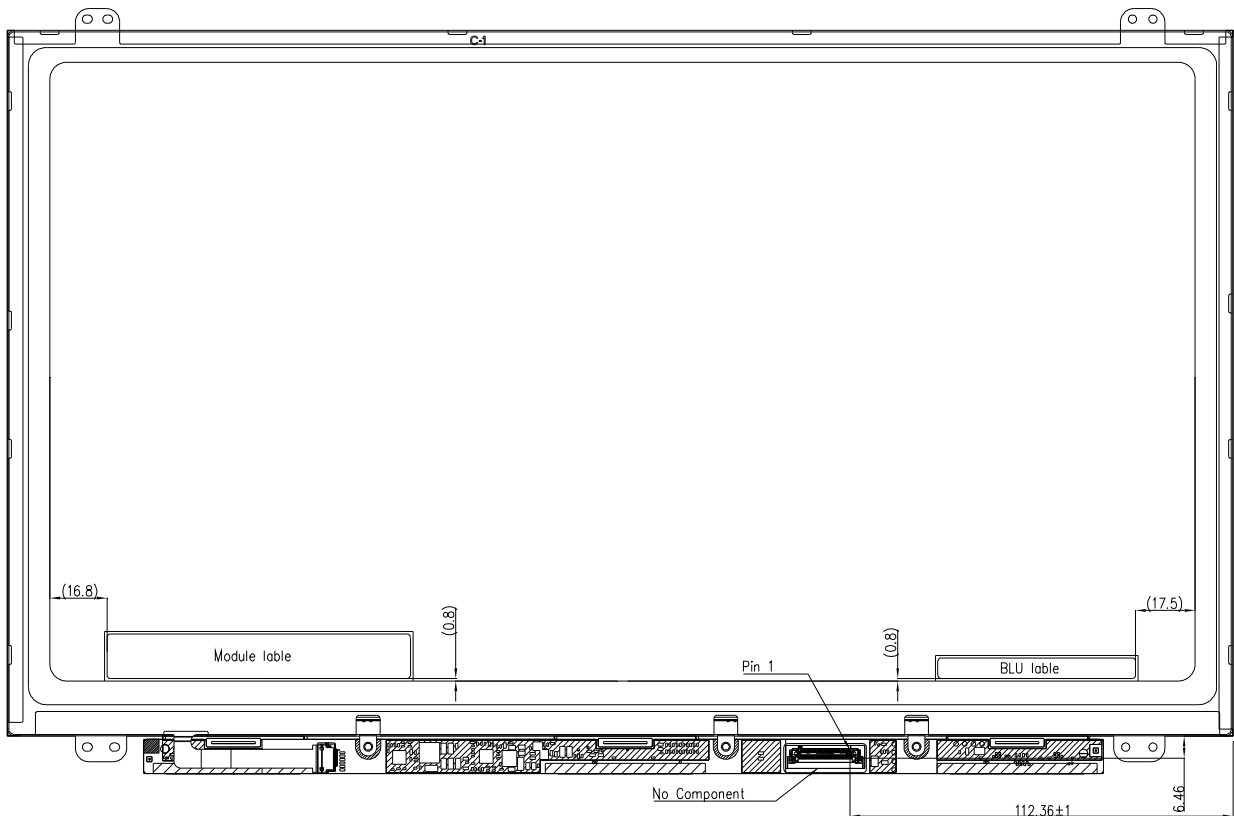
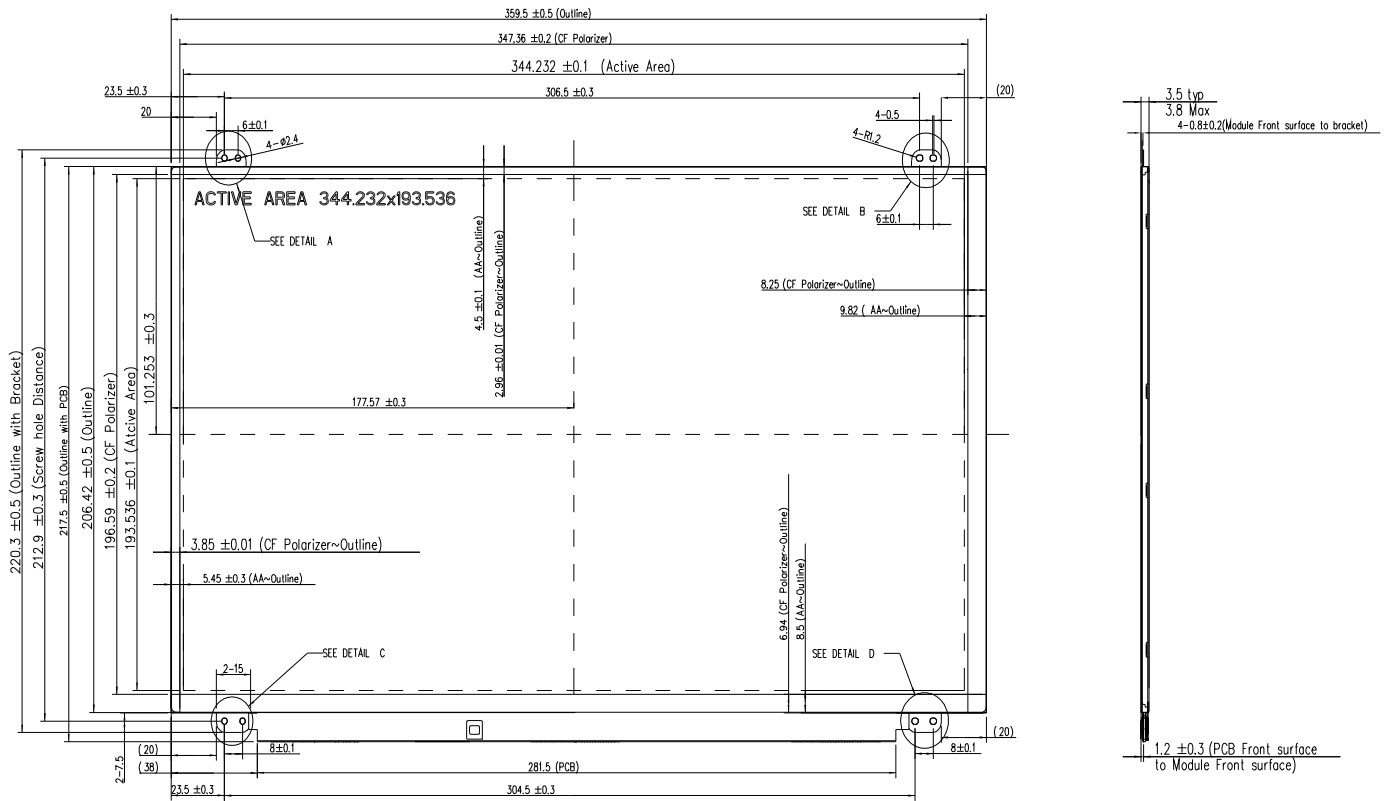

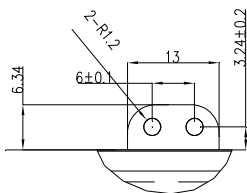
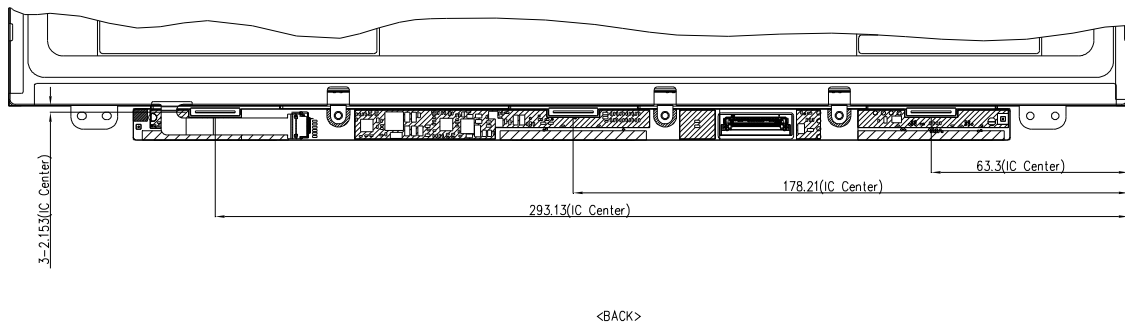
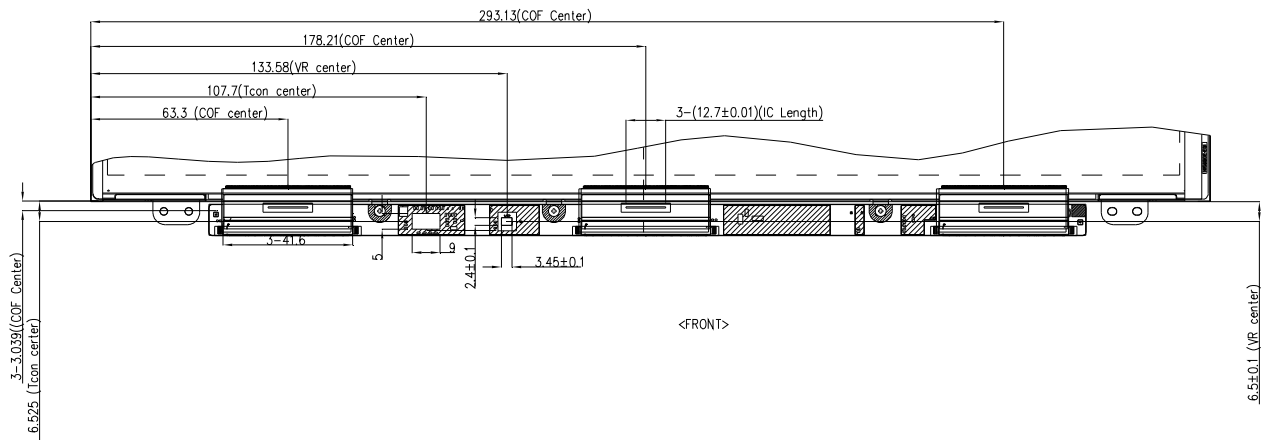

DETAIL A
SCALE 2:1

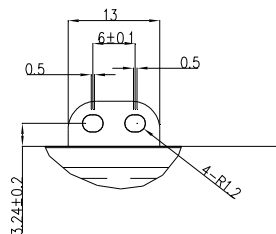

DETAIL B
SCALE 2:1

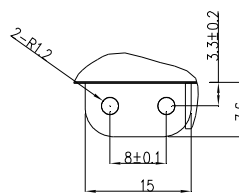

DETAIL C
SCALE 2:1

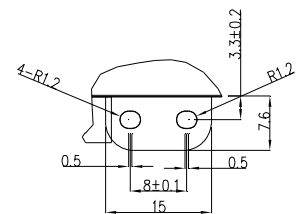

DETAIL D
SCALE 2:1

NOTES:

- 1.LCD MODULE INPUT CONNECTOR: I-PEX 20455-030E-12 OR EQUIVALENT
- 2.IN ORDER TO AVOID ABNORMAL DISPLAY,POOLING AND WHITE SPOT,
NO OVERLAPPING IS SUGGESTED AT CABLES,ANTENNAS,CAMERA,WLAN,
WAN OR OTHER FOREIGN OBJECTS OVER ,FPC,TCON AND VR LOCATIONS.
- 3.EDP CONNECTOR IS MASURED AT PIN1 AND ITS MATING LINE
- 4.MODULE FLATNESS SPEC 2mm MAX.(Spec will be modified after DVT check)
5. "()" MARKS THE REFERENCE DIMENSIONS.

Appendix. SYSTEM COVER DESIGN GUIDANCE

| | |
|------------|---|
| 0. | Permanent deformation of system cover after reliability test |
| | |
| Definition | System cover including front and rear cover may deform during reliability test. Permanent deformation of system front and rear cover after reliability test should not interfere with panel. Because it may cause issues such as pooling, abnormal display, and also white spot. |
| 1. | Design gap A between panel & any components on system rear-cover |
| | |
| Definition | <p>a). Sufficient gap between panel & system is recommended for preventing from backpack or pogo test fail.</p> <p>b). Zero gap from panel's maximum thickness boundary to any components, foreign objects, wire, cable or extrusion on system cover inner surface is forbidden.</p> <p>c). Interference between panel and system rear-cover is forbidden after reliability test.</p> <p>Note: Recommend at least 0.6mm gap. If the gap is less than recommendation, please check with INX.</p> |
| 2 | Design gap B1 & B2 between panel & protrusions |

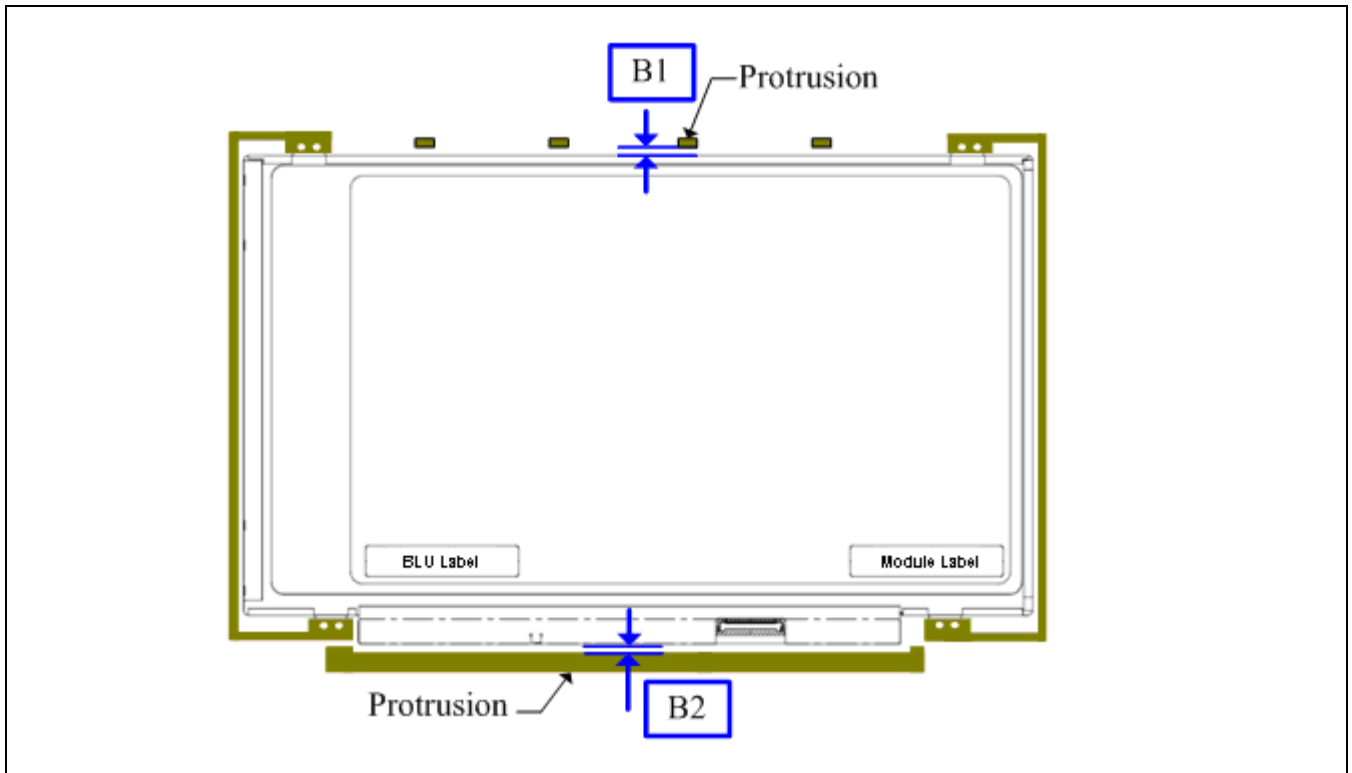

| | |
|------------|---|
| Definition | <p>a). Sufficient gap is recommended between panel & protrusions for preventing from shock related failures.</p> <p>b). Interference between panel and system rear-cover is forbidden after reliability test.</p> <p>Note: Recommend at least 2.0mm gap. If the gap is less than recommendation, please check with INX.</p> |
|------------|---|

| | |
|---|---|
| 3 | Design gap C between system front-cover & panel surface. |
|---|---|

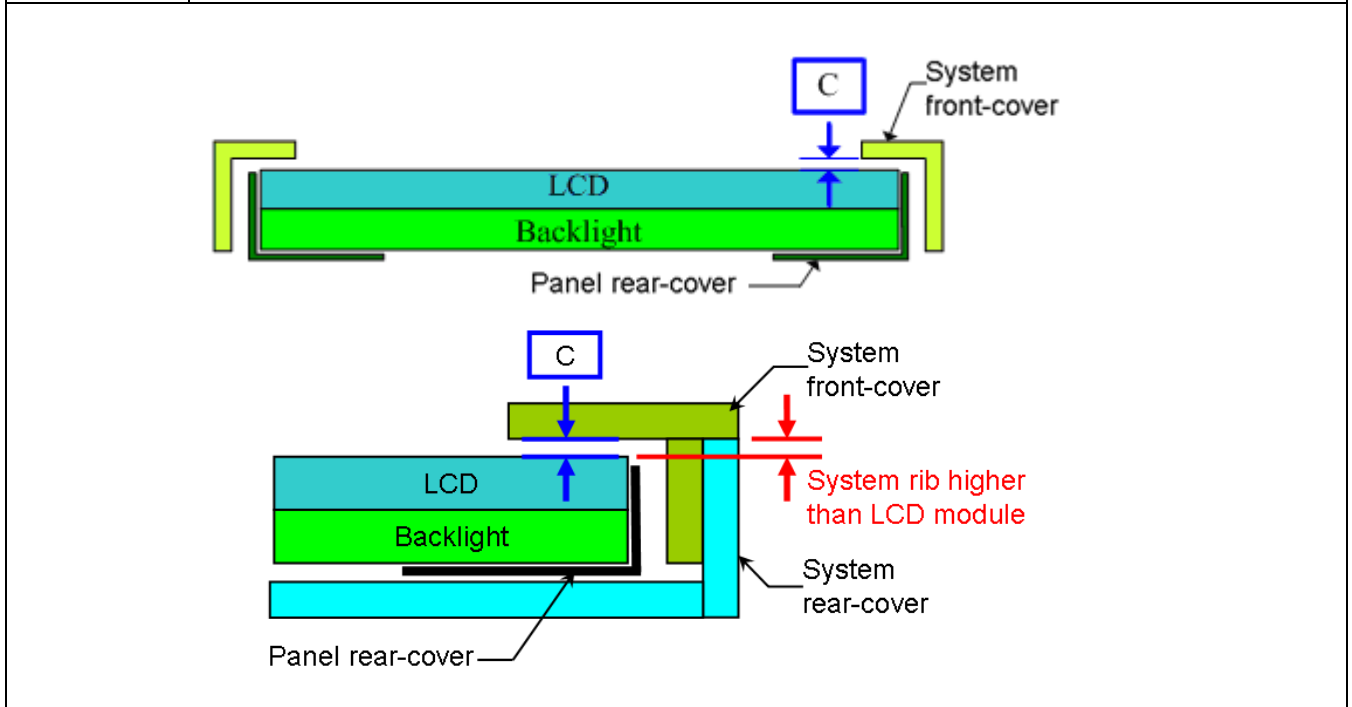

| | |
|------------|--|
| Definition | <p>a). Sufficient gap between system front-cover & panel surface is a must for preventing from pooling or glass broken.</p> <p>b). Interference between panel and system (front & rear) cover is forbidden after reliability</p> |
|------------|--|

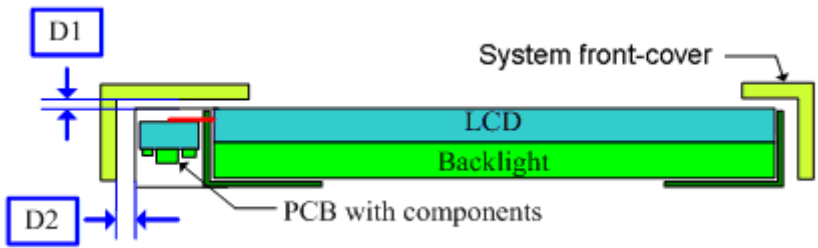
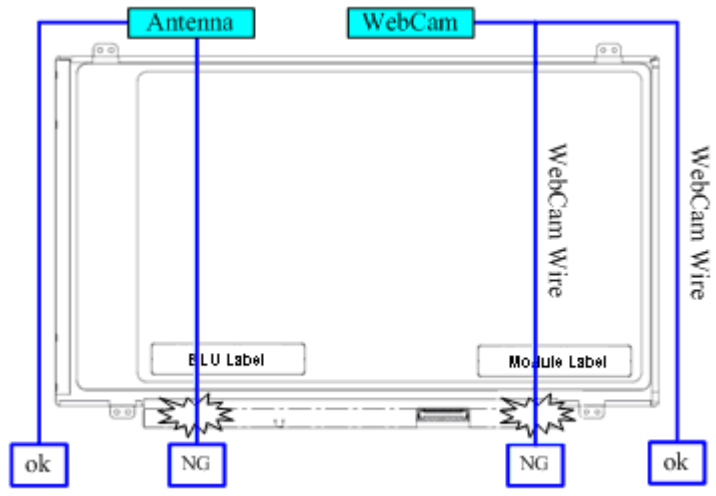
| | |
|------------|--|
| | <p>test.</p> <p>c). Interference is also forbidden in the act of system front-cover deformation during swing test, hinge test, knock test, or during pooling inspection procedure.</p> <p>d). To remain sufficient gap, design with system rib higher than maximum panel thickness is recommended.</p> <p>Note: Recommend at least 0.1mm gap. If the gap is less than recommendation, please check with INX.</p> |
| 4 | <p>Design gap D1 & D2 between system front-cover & PCB Assembly.</p>  |
| Definition | <p>a). Sufficient gap between system front-cover & PCB assembly is a must for preventing from abnormal display after backpack test, hinge test, twist test or pogo test.</p> <p>b). Interference between panel and system front-cover is forbidden after reliability test.</p> <p>c). Interference is also forbidden in the act of system front-cover deformation during swing test, hinge test, knock test, or during pooling inspection procedure.</p> <p>d). To remain sufficient gap, design with system rib higher than maximum panel thickness is recommended.</p> <p>Note: Recommend for D1 at least 0.1mm gap, D2 at least 2.0mm gap. If the gap is less than recommendation, please check with INX.</p> |
| 5 | <p>Interference examination of antenna cable and WebCam wire</p>  |
| Definition | <p>a). Antenna cable or WebCam wire overlap with panel outline is forbidden for preventing from abnormal display & white spot after backpack test, hinge test, twist test or pogo test.</p> <p>b). Antenna cable or WebCam wire bypass panel outline is recommended.</p> <p>c). Interference between panel and system rear-cover is forbidden after reliability test.</p> |
| 6 | <p>System rear-cover inner surface examination</p> |

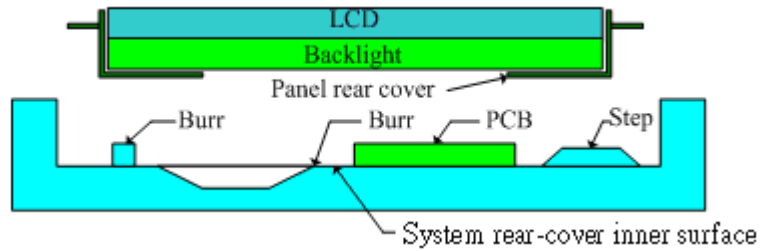

Definition

- a). Burr at logo edge, step, protrusion or PCB board will easily cause white spot or glass broken.
- b). Keeping flat surface underneath backlight is recommended.
- c). Interference between panel and system cover is forbidden after reliability test.

7 **Tape/sponge design on system inner surface**

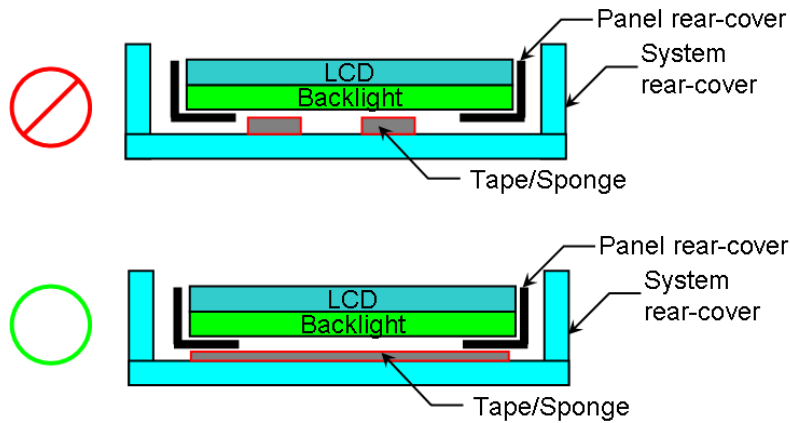

Definition

- a) To prevent abnormal display & white spot after scuffing test, hinge test, pogo test, backpack test, it is not recommended to add tape/sponge in separate location. Since each tape/sponge may act as pressure concentration location.
- b) We suggest to design with a tape/sponge that well covered under panel rear-cover.
- c). Interference between panel and system rear-cover is forbidden after reliability test.

8 **Assembly SOP examination**

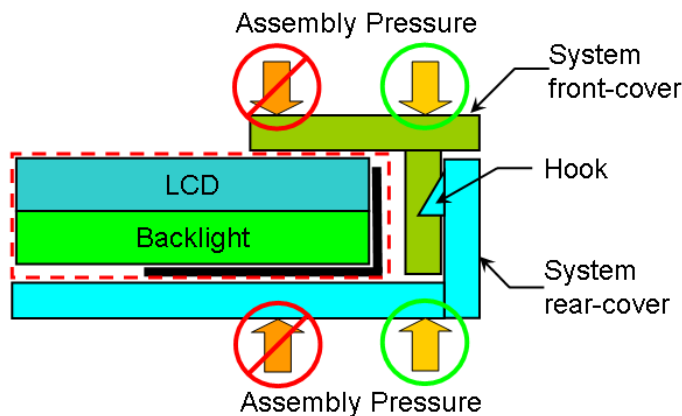

Definition

To prevent panel crack during system front-cover assembly process with hook design, it is

| | |
|------------|---|
| | prohibited to press panel or any location that related directly to the panel. |
| 9 | Assembly SOP examination |
| | |
| Definition | To prevent panel crack during system front-cover assembly process without hook design, it is only allowed to give slight pressure with large contact area. This can help to distribute the stress and prevent stress concentration. Also it is suggest to put the system on a flat surface stage during the assembly. |
| 10 | Material used for system rear-cover |
| | |
| Definition | <p>a) To prevent abnormal display & white spot after scuffing test, hinge test, pogo test, backpack test, as the poor rigidity result from deformation of system rear-cover during the test.</p> <p>b) We suggest using aluminum-magnesium alloy as the system rear-cover material with thickness min 1.5mm, instead of using PC/ABS.</p> |
| 11 | System base unit design near keyboard and mouse pad |
| | |
| Definition | To prevent abnormal display & white spot after scuffing test, hinge test, pogo test, backpack test, no sharp edge design is allowed in any area that may damage the panel during the test. We suggest to remove all sharp edges, or to reduce the thickness difference of keyboard/mouse pad from the nearby surface. |

| | |
|--|--|
| 12 | Screw boss height design |
| <p>The diagram consists of two cross-sectional views of a panel assembly. The top view is marked with a red prohibition sign (a circle with a diagonal slash). It shows a stack of components: LCD (blue), Backlight (green), and Panel rear-cover (light blue). A red screw is shown passing through a red screw boss on the System rear-cover (light blue) into the Panel rear-cover. A red double-headed arrow labeled 'Gap' indicates the distance between the bottom surface of the Panel rear-cover and the top surface of the screw boss. The bottom view is marked with a green circle. It shows the same components. A blue double-headed arrow labeled 'Gap' indicates the distance between the bottom surface of the Panel rear-cover and the bottom surface of the System rear-cover. Labels include: LCD, Backlight, Panel rear-cover, System rear-cover, Screw, Screw boss, and Gap.</p> | |
| Definition | <p>a). Gap left between panel rear-cover bracket and screw boss surface is prohibited. b). To remain sufficient gap between panel and system rear-cover, screw boss height must be designed with respect to the height of bracket bottom surface to panel bottom surface + flatness change of panel itself.</p> |