

Doc. Number:

- Tentative Specification
 Preliminary Specification
 Approval Specification

MODEL NO.: N164HGE
SUFFIX: L12

Customer:
APPROVED BY
SIGNATURE
Name / Title

Note

Please return 1 copy for your confirmation with your signature and comments.

Approved By	Checked By	Prepared By
楊竣傑	陳逸銘	歐陽志全
2010-12-30 16:03:43 CST	2010-12-22 18:11:23 CST	2010-12-22 16:06:23 CST

CONTENTS

1. GENERAL DESCRIPTION	4
1.1 OVERVIEW	4
1.2 GENERAL SPECIFICATIONS	4
2. MECHANICAL SPECIFICATIONS	4
2.1 CONNECTOR TYPE	4
3. ABSOLUTE MAXIMUM RATINGS	5
3.1 ABSOLUTE RATINGS OF ENVIRONMENT	5
3.2 ELECTRICAL ABSOLUTE RATINGS.....	5
3.2.1 TFT LCD MODULE	5
4. ELECTRICAL SPECIFICATIONS.....	6
4.1 FUNCTION BLOCK DIAGRAM.....	6
4.2. INTERFACE CONNECTIONS	6
4.3 ELECTRICAL CHARACTERISTICS.....	8
4.3.1 LCD ELETRONICS SPECIFICATION.....	8
4.3.2 LED CONVERTER SPECIFICATION.....	10
4.3.3 BACKLIGHT UNIT.....	12
4.4 LVDS INPUT SIGNAL TIMING SPECIFICATIONS	13
4.4.1 LVDS DC SPECIFICATIONS	13
4.4.2 LVDS DATA FORMAT	13
4.4.3 COLOR DATA INPUT ASSIGNMENT	14
4.5 DISPLAY TIMING SPECIFICATIONS	15
4.6 POWER ON/OFF SEQUENCE	16
5. OPTICAL CHARACTERISTICS	17
5.1 TEST CONDITIONS.....	17
5.2 OPTICAL SPECIFICATIONS	17
6. RELIABILITY TEST ITEM	20
7. PACKING.....	21
7.1 MODULE LABEL	21
7.2 CARTON	22
7.3 PALLET.....	23
8. PRECAUTIONS.....	24
8.1 HANDLING PRECAUTIONS.....	24
8.2 STORAGE PRECAUTIONS	24
8.3 OPERATION PRECAUTIONS.....	24
Appendix. EDID DATA STRUCTURE.....	25
Appendix. OUTLINE DRAWING	28

REVISION HISTORY

Version	Date	Page	Description
0.0	Oct.13, 2010	All	Spec Ver.0.0 was first issued.
1.0	Dec.22, 2010	8	Update LCD electronics specification
		22~23	Update CARTON & PALLET packing method
		25~27	Update EDID code

1. GENERAL DESCRIPTION

1.1 OVERVIEW

N164HGE-L12 is a 16.4" (16.392" diagonal) TFT Liquid Crystal Display module with LED Backlight unit and 40 pins LVDS interface. This module supports 1920 x 1080 FHD mode and can display 262,144 colors. The optimum viewing angle is at 6 o'clock direction.

1.2 GENERAL SPECIFICATIONS

Item	Specification	Unit	Note
Screen Size	16.392" diagonal		
Driver Element	a-si TFT active matrix	-	-
Pixel Number	1920 x R.G.B. x 1080	pixel	-
Pixel Pitch	0.189 (H) x 0.189 (V)	mm	-
Pixel Arrangement	RGB vertical stripe	-	-
Display Colors	262,144	color	-
Transmissive Mode	Normally white	-	-
Surface Treatment	Hard coating (3H), Anti-glare	-	-
Luminance, White	300	Cd/m2	
Power Consumption	Total 13.97W (Max.) @ cell 2.43 W (Max.), BL 11.56 W (Max.)		(1)

Note (1) The specified power consumption (with converter efficiency) is under the conditions at VCCS = 3.3 V, $f_v = 60$ Hz, LED_VCCS = Typ, $f_{PWM} = 200$ Hz, Duty=100% and $T_a = 25 \pm 2$ °C, whereas mosaic pattern is displayed.

2. MECHANICAL SPECIFICATIONS

Item		Min.	Typ.	Max.	Unit	Note
Module Size	Horizontal (H)	375.7	376.2	376.7	mm	(1)
	Vertical (V)	218.6	219.1	219.6	mm	
	Thickness (T)	-	5.5	5.8	mm	
Bezel Area	Horizontal	366.74	366.94	367.14	mm	
	Vertical	207.52	207.72	207.92	mm	
Active Area	Horizontal	362.58	362.88	363.18	mm	
	Vertical	203.82	204.12	204.42	mm	
Weight		-	520	535	g	

Note (1) Please refer to the attached drawings for more information of front and back outline dimensions.

2.1 CONNECTOR TYPE

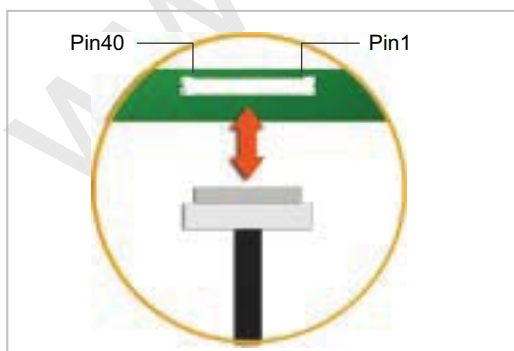

Please refer Appendix Outline Drawing for detail design.

Connector Part No.: Foxconn GS13401-1110S-7H, I-PEX 20455-040E-12 or equivalent

User's connector Part No: IPEX-20453-040T-01 or equivalent

3. ABSOLUTE MAXIMUM RATINGS

3.1 ABSOLUTE RATINGS OF ENVIRONMENT

Item	Symbol	Value		Unit	Note
		Min.	Max.		
Storage Temperature	T _{ST}	-20	+60	°C	(1)
Operating Ambient Temperature	T _{OP}	0	+50	°C	(1), (2)

Note (1) (a) 90 %RH Max. (T_a ≤ 40 °C).

(b) Wet-bulb temperature should be 39 °C Max. (T_a > 40 °C).

(c) No condensation.

Note (2) The temperature of panel surface should be 0 °C min. and 60 °C max.

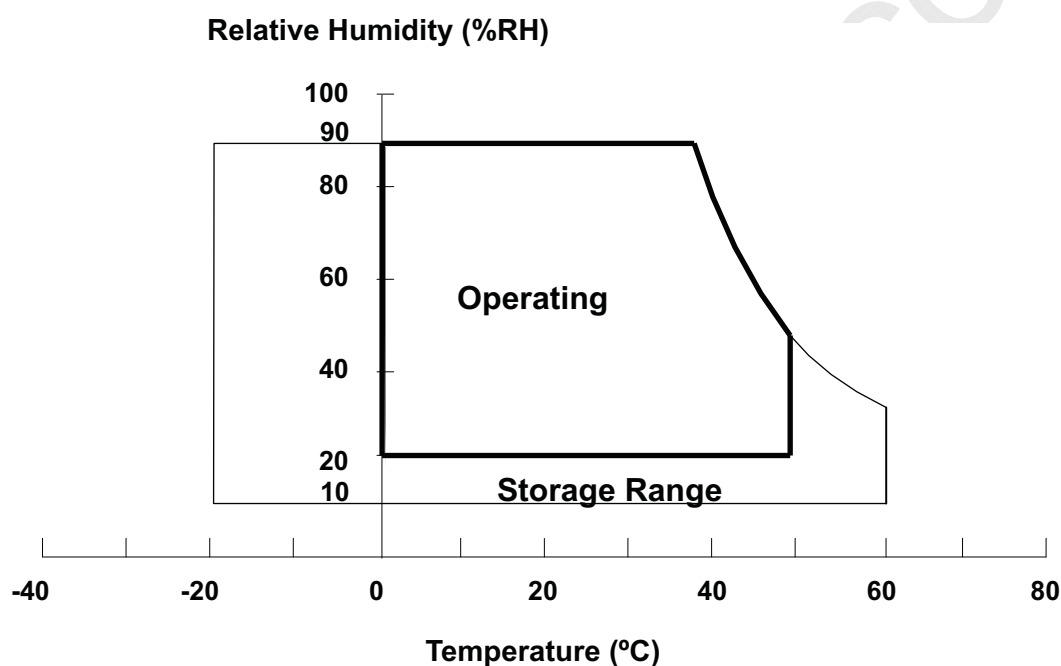

3.2 ELECTRICAL ABSOLUTE RATINGS

3.2.1 TFT LCD MODULE

Item	Symbol	Value		Unit	Note
		Min.	Max.		
Power Supply Voltage	V _{CCS}	0	+3.6	V	(1)
Logic Input Voltage	V _{IN}	0	+3.6	V	
Converter Input Voltage	LED_V _{CCS}	0	21	V	(1)
Converter Control Signal Voltage	LED_PWM,	0	+3.6	V	(1)
Converter Control Signal Voltage	LED_EN	0	+3.6	V	(1)

Note (1) Stresses beyond those listed in above "ELECTRICAL ABSOLUTE RATINGS" may cause permanent damage to the device. Normal operation should be restricted to the conditions described in "ELECTRICAL CHARACTERISTICS".

4. ELECTRICAL SPECIFICATIONS

4.1 FUNCTION BLOCK DIAGRAM

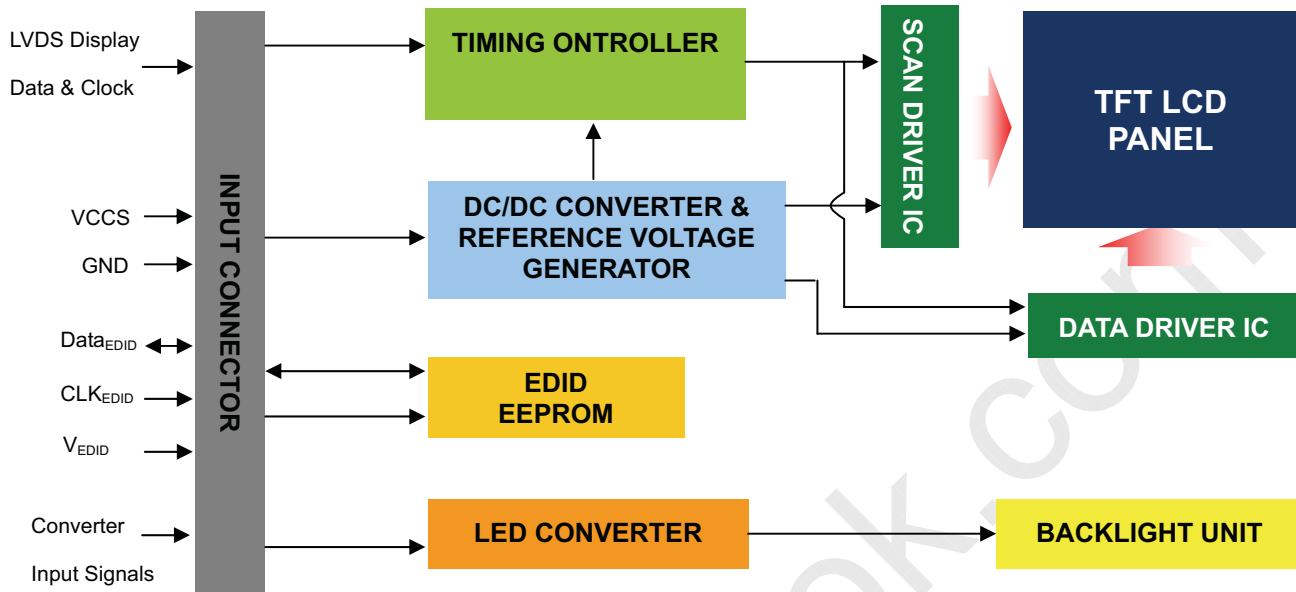

4.2. INTERFACE CONNECTIONS

PIN ASSIGNMENT

Pin	Symbol	Description	Remark
1	NC	No Connection (Reserve)	
2	VCCS	Power Supply (3.3V typ.)	
3	VCCS	Power Supply (3.3V typ.)	
4	VEDID	DDC 3.3V power	
5	NC	No Connection (Reserved for CMI test)	
6	CLKEDID	DDC clock	
7	DATAEDID	DDC data	
8	RXO0-	LVDS Differential Data Input (Odd)	R0-R5, G0
9	RXO0+	LVDS Differential Data Input (Odd)	
10	VSS	Ground	
11	RXO1-	LVDS Differential Data Input (Odd)	G1~G5, B0, B1
12	RXO1+	LVDS Differential Data Input (Odd)	
13	VSS	Ground	
14	RXO2-	LVDS Differential Data Input (Odd)	B2-B5, HS, VS, DE
15	RXO2+	LVDS Differential Data Input (Odd)	
16	VSS	Ground	
17	RXOC-	LVDS Clock Data Input (Odd)	LVDS CLK
18	RXOC+	LVDS Clock Data Input (Odd)	
19	VSS	Ground	
20	RXE0-	LVDS Differential Data Input (Even)	R0-R5, G0
21	RXE0+	LVDS Differential Data Input (Even)	
22	VSS	Ground	
23	RXE1-	LVDS Differential Data Input (Even)	G1~G5, B0, B1

24	RXE1+	LVDS Differential Data Input (Even)	
25	VSS	Ground	
26	RXE2-	LVDS Differential Data Input (Even)	B2-B5,HS,VS, DE
27	RXE2+	LVDS Differential Data Input (Even)	
28	VSS	Ground	LVDS CLK
29	RXEC-	LVDS Clock Data Input (Even)	
30	RXEC+	LVDS Clock Data Input (Even)	
31	LED_GND	LED Ground	
32	LED_GND	LED Ground	
33	LED_GND	LED Ground	
34	NC	No Connection (Reserve)	
35	LED_PWM	PWM Control Signal of LED Converter	
36	LED_EN	Enable Control Signal of LED Converter	
37	NC	No Connection (Reserve)	
38	LED_VCCS	LED Power Supply	
39	LED_VCCS	LED Power Supply	
40	LED_VCCS	LED Power Supply	

Note (1) The first pixel is odd as shown in the following figure.

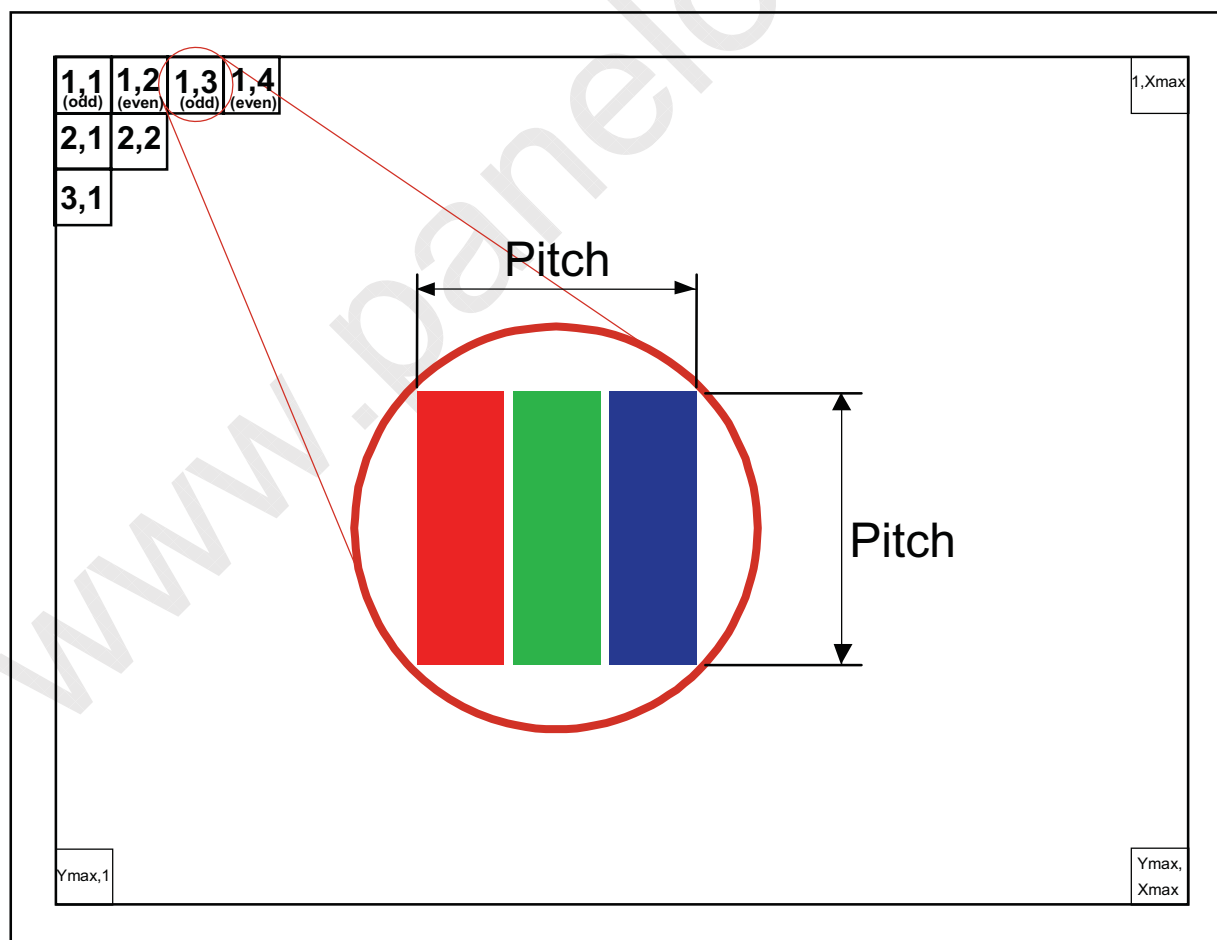

4.3 ELECTRICAL CHARACTERISTICS

4.3.1 LCD ELETRONICS SPECIFICATION

Parameter	Symbol	Value			Unit	Note	
		Min.	Typ.	Max.			
Power Supply Voltage	VCCS	3.0	3.3	3.6	V	(1)-	
Ripple Voltage	V_{RP}	-	50	-	mV	(1)-	
Inrush Current	I_{RUSH}	-	-	2	A	(1),(2)	
Power Supply Current	Mosaic	ICC	TBD	(420)	(500)	mA	(3)a
	Black		TBD	(550)	(600)	mA	(3)b

Note (1) The ambient temperature is $T_a = 25 \pm 2$ °C.

Note (2) I_{RUSH} : the maximum current when VCCS is rising

I_{IS} : the maximum current of the first 100ms after power-on

Measurement Conditions: Shown as the following figure. Test pattern: black.

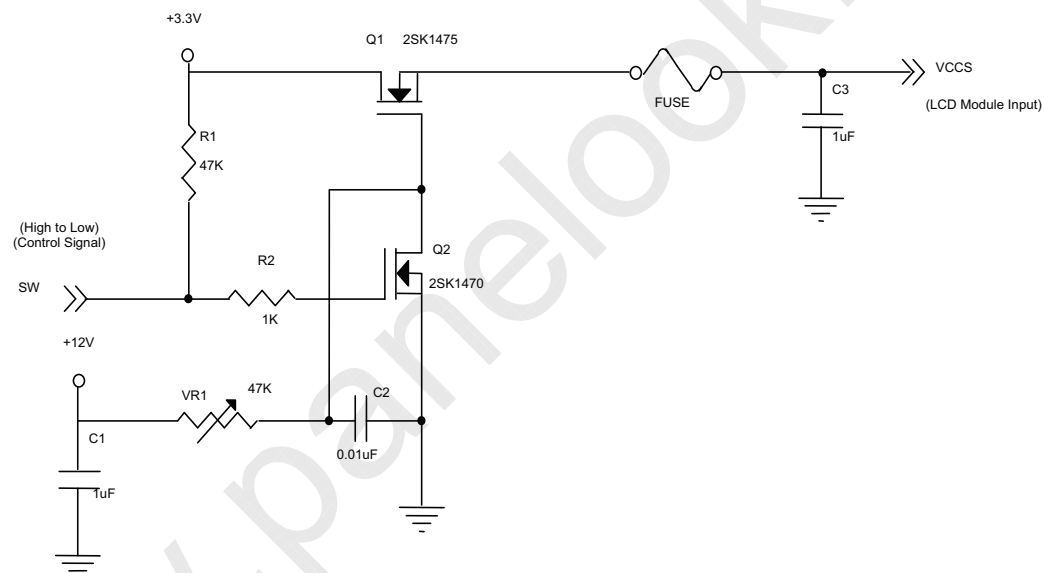

VCCS rising time is 0.5ms

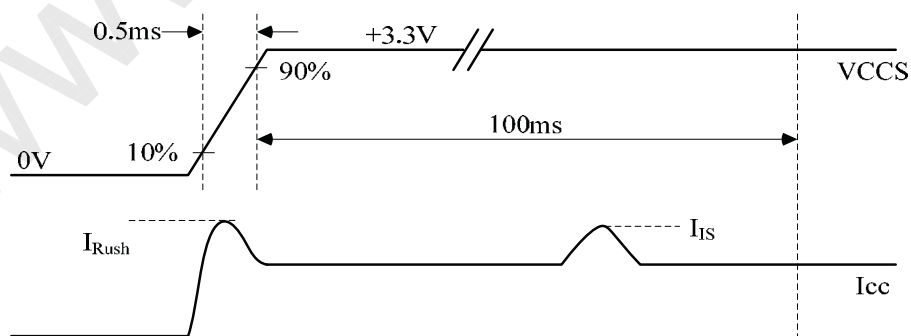

Note (3) The specified power supply current is under the conditions at $V_{CCS} = 3.3\text{ V}$, $T_a = 25 \pm 2\text{ }^\circ\text{C}$, DC Current and $f_v = 60\text{ Hz}$, whereas a power dissipation check pattern below is displayed.

a. Mosaic Pattern

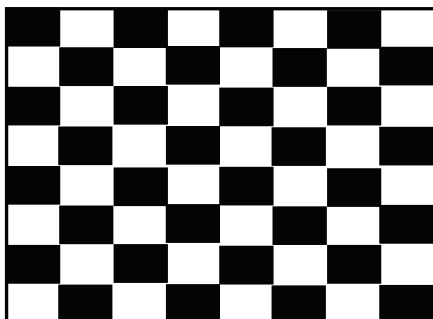

Active Area

b. Black Pattern



Active Area

www.panelook.com

4.3.2 LED CONVERTER SPECIFICATION

Parameter		Symbol	Value			Unit	Note
			Min.	Typ.	Max.		
Converter Input power supply voltage		LED_Vccs	6.0	12.0	21.0	V	
Converter Inrush Current		I _{LED_RUSH}	-	-	(2)	A	(1)
EN Control Level	Backlight On		2.3	-	5.0	V	
	Backlight Off		0	-	0.5	V	
PWM Control Level	PWM High Level		2.3	-	5.0	V	
	PWM Low Level		0	-	0.5	V	
PWM Control Duty Ratio			10	-	100	%	
			5	-	100	%	(2)
PWM Control Permissible Ripple Voltage		V _{PWM_pp}	-	-	100	mV	
PWM Control Frequency		f _{PWM}	190	-	230	Hz	(3)
LED Power Current	LED_VCCS =Typ.	I _{LED}	(711.3)	(828.2)	(963)	mA	(4)

Note (1) I_{LED_RUSH}: the maximum current when LED_VCCS is rising,

I_{LED_1S}: the maximum current of the first 100ms after power-on,

Measurement Conditions: Shown as the following figure. LED_VCCS = Typ, Ta = 25 ± 2 °C, f_{PWM} = 200 Hz, Duty=100%.

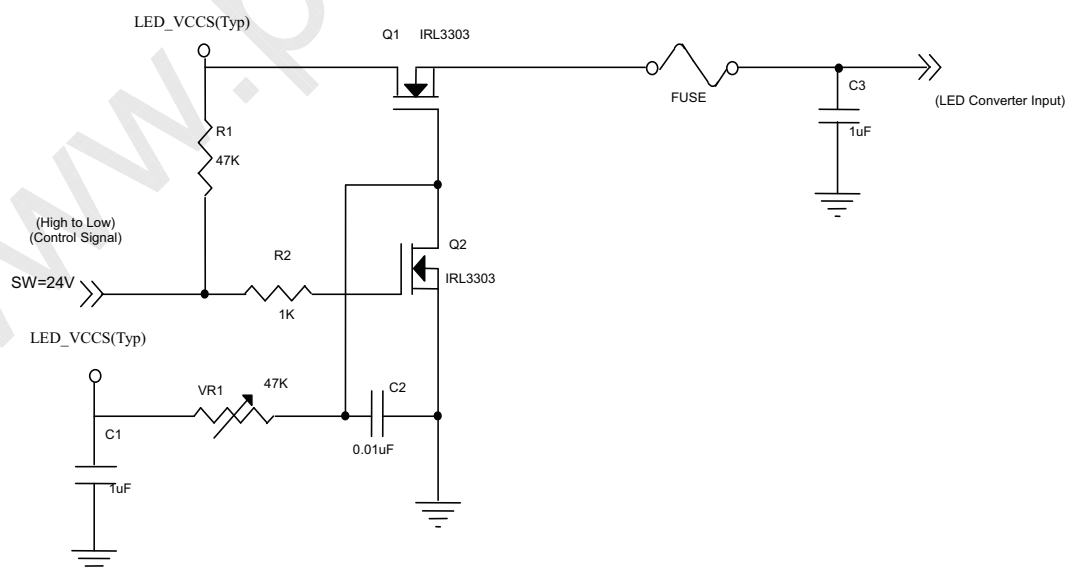

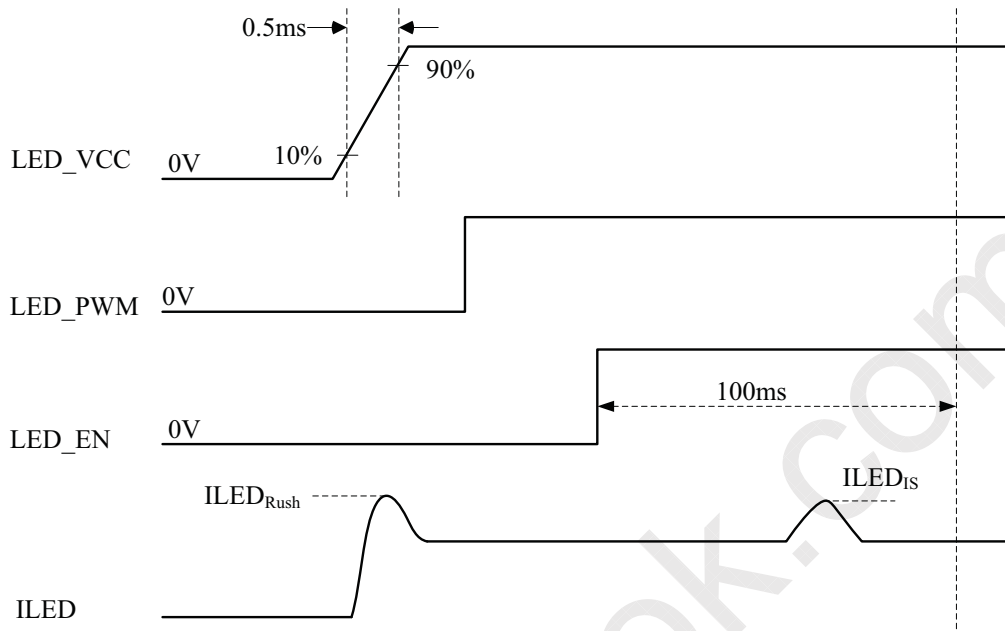
VLED rising time is 0.5ms

Note (2) If the PWM control duty ratio is less than 10%, there is some possibility that acoustic noise or backlight flash can be found. And it is also difficult to control the brightness linearity.

Note (3) If PWM control frequency is applied in the range less than 1KHz, the “waterfall” phenomenon on the screen may be found. To avoid the issue, it’s a suggestion that PWM control frequency should follow the criterion as below.

PWM control frequency f_{PWM} should be in the range

$$(N + 0.33) * f \leq f_{PWM} \leq (N + 0.66) * f$$

N : Integer ($N \geq 3$)

f : Frame rate

Note (4) The specified LED power supply current is under the conditions at “LED_VCCS = Typ.”, $T_a = 25 \pm 2 \text{ }^\circ\text{C}$, $f_{PWM} = 200 \text{ Hz}$, Duty=100%.

4.3.3 BACKLIGHT UNIT
 $T_a = 25 \pm 2 \text{ }^\circ\text{C}$

Parameter	Symbol	Value			Unit	Note
		Min.	Typ.	Max.		
LED Light Bar Power Supply Voltage	V_L	30.8	34.1	37.4	V	(1)(2)(Duty100%)
LED Light Bar Power Supply Current	I_L	(239)	(252)	(265)	mA	
Power Consumption	P_L	7.36	8.59	9.91	W	(3)
LED Life Time	L_{BL}	15000	-	-	Hrs	(4)

Note (1) LED current is measured by utilizing a high frequency current meter as shown below :

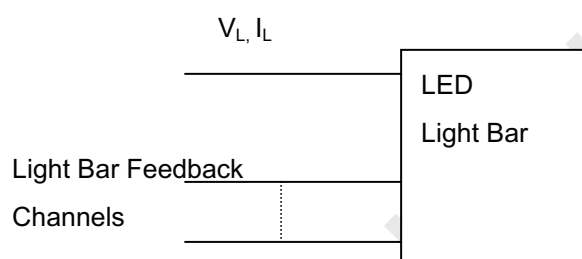

Note (2) For better LED light bar driving quality, it is recommended to utilize the adaptive boost converter with current balancing function to drive LED light-bar.

Note (3) $P_L = I_L \times V_L$ (Without LED converter transfer efficiency)

Note (4) The lifetime of LED is defined as the time when it continues to operate under the conditions at $T_a = 25 \pm 2 \text{ }^\circ\text{C}$ and $I_L = 42 \text{ mA}$ (Per EA) until the brightness becomes $\leq 50\%$ of its original value.

4.4 LVDS INPUT SIGNAL TIMING SPECIFICATIONS

4.4.1 LVDS DC SPECIFICATIONS

Parameter	Symbol	Value			Unit	Note
		Min.	Typ.	Max.		
LVDS Differential Input High Threshold	$V_{TH(LVDS)}$	-	-	+100	mV	(1), $V_{CM}=1.2V$
LVDS Differential Input Low Threshold	$V_{TL(LVDS)}$	-100	-	-	mV	(1), $V_{CM}=1.2V$
LVDS Common Mode Voltage	V_{CM}	1.125	-	1.375	V	(1)
LVDS Differential Input Voltage	$ V_{ID} $	100	-	600	mV	(1)
LVDS Terminating Resistor	R_T	-	100	-	Ohm	-

Note (1) The parameters of LVDS signals are defined as the following figures.

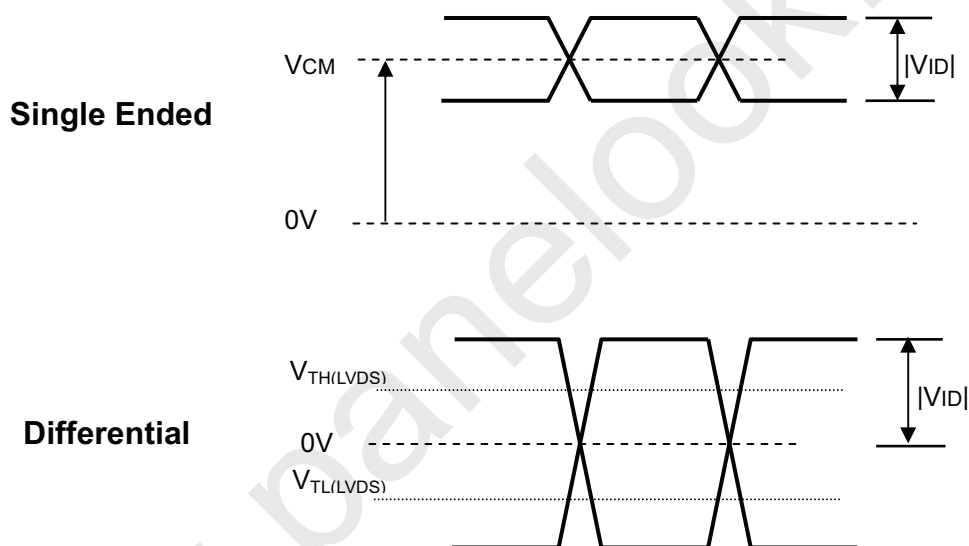

4.4.2 LVDS DATA FORMAT

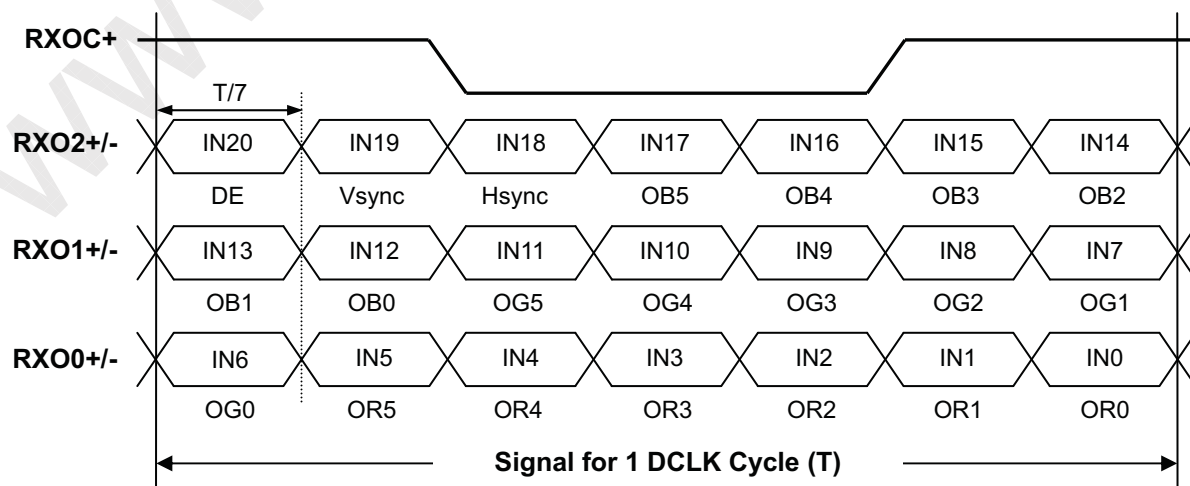

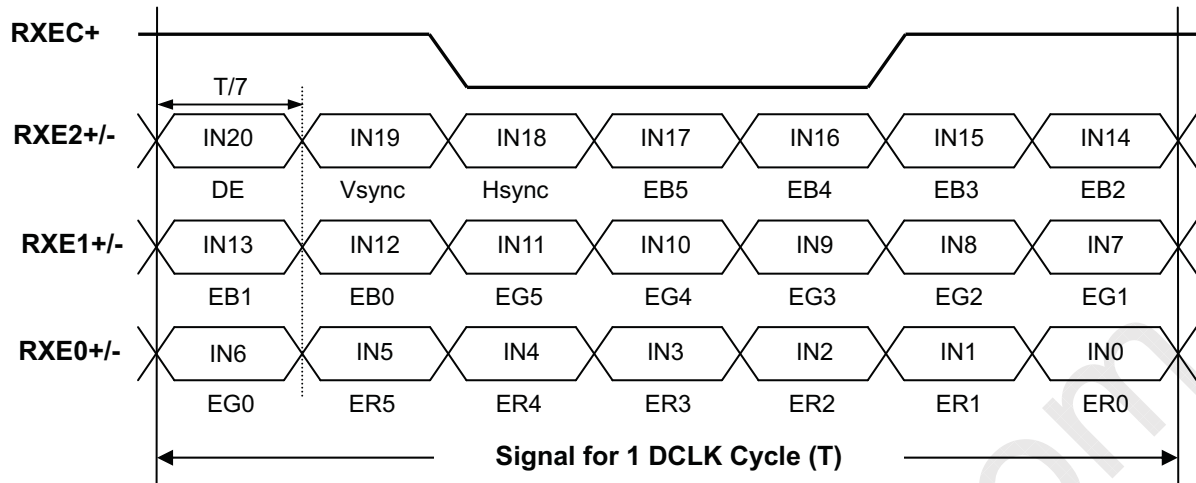

4.4.3 COLOR DATA INPUT ASSIGNMENT

The brightness of each primary color (red, green and blue) is based on the 6-bit gray scale data input for the color. The higher the binary input the brighter the color. The table below provides the assignment of color versus data input.

Color		Data Signal																	
		Red						Green						Blue					
		R5	R4	R3	R2	R1	R0	G5	G4	G3	G2	G1	G0	B5	B4	B3	B2	B1	B0
Basic Colors	Black	0	0	0	0	0	0	0	0	0	0	0	0	0	0	0	0	0	0
	Red	1	1	1	1	1	1	0	0	0	0	0	0	0	0	0	0	0	0
	Green	0	0	0	0	0	0	1	1	1	1	1	1	0	0	0	0	0	0
	Blue	0	0	0	0	0	0	0	0	0	0	0	0	1	1	1	1	1	1
	Cyan	0	0	0	0	0	0	1	1	1	1	1	1	1	1	1	1	1	1
	Magenta	1	1	1	1	1	1	0	0	0	0	0	0	1	1	1	1	1	1
	Yellow	1	1	1	1	1	1	1	1	1	1	1	1	0	0	0	0	0	0
	White	1	1	1	1	1	1	1	1	1	1	1	1	1	1	1	1	1	1
Gray Scale Of Red	Red(0)/Dark	0	0	0	0	0	0	0	0	0	0	0	0	0	0	0	0	0	0
	Red(1)	0	0	0	0	0	1	0	0	0	0	0	0	0	0	0	0	0	0
	Red(2)	0	0	0	0	1	0	0	0	0	0	0	0	0	0	0	0	0	0
	:	:	:	:	:	:	:	:	:	:	:	:	:	:	:	:	:	:	:
	:	:	:	:	:	:	:	:	:	:	:	:	:	:	:	:	:	:	:
	:	:	:	:	:	:	:	:	:	:	:	:	:	:	:	:	:	:	:
	Red(61)	1	1	1	1	0	1	0	0	0	0	0	0	0	0	0	0	0	0
	Red(62)	1	1	1	1	1	0	0	0	0	0	0	0	0	0	0	0	0	0
Red(63)	1	1	1	1	1	1	0	0	0	0	0	0	0	0	0	0	0	0	
Gray Scale Of Green	Green(0)/Dark	0	0	0	0	0	0	0	0	0	0	0	0	0	0	0	0	0	0
	Green(1)	0	0	0	0	0	0	0	0	0	0	0	1	0	0	0	0	0	0
	Green(2)	0	0	0	0	0	0	0	0	0	0	1	0	0	0	0	0	0	0
	:	:	:	:	:	:	:	:	:	:	:	:	:	:	:	:	:	:	:
	:	:	:	:	:	:	:	:	:	:	:	:	:	:	:	:	:	:	:
	:	:	:	:	:	:	:	:	:	:	:	:	:	:	:	:	:	:	:
	Green(61)	0	0	0	0	0	0	1	1	1	1	0	1	0	0	0	0	0	0
	Green(62)	0	0	0	0	0	0	1	1	1	1	1	0	0	0	0	0	0	0
Green(63)	0	0	0	0	0	0	1	1	1	1	1	1	0	0	0	0	0	0	
Gray Scale Of Blue	Blue(0)/Dark	0	0	0	0	0	0	0	0	0	0	0	0	0	0	0	0	0	0
	Blue(1)	0	0	0	0	0	0	0	0	0	0	0	0	0	0	0	0	0	1
	Blue(2)	0	0	0	0	0	0	0	0	0	0	0	0	0	0	0	0	1	0
	:	:	:	:	:	:	:	:	:	:	:	:	:	:	:	:	:	:	:
	:	:	:	:	:	:	:	:	:	:	:	:	:	:	:	:	:	:	:
	:	:	:	:	:	:	:	:	:	:	:	:	:	:	:	:	:	:	:
	Blue(61)	0	0	0	0	0	0	0	0	0	0	0	0	1	1	1	1	0	1
	Blue(62)	0	0	0	0	0	0	0	0	0	0	0	0	1	1	1	1	1	0
Blue(63)	0	0	0	0	0	0	0	0	0	0	0	0	1	1	1	1	1	1	

Note (1) 0: Low Level Voltage, 1: High Level Voltage

4.5 DISPLAY TIMING SPECIFICATIONS

The input signal timing specifications are shown as the following table and timing diagram.

Signal	Item	Symbol	Min.	Typ.	Max.	Unit	Note
DCLK	Frequency	1/Tc	(70.54)	(74.25)	(77.97)	MHz	-
DE	Vertical Total Time	TV	NA	(1125)	NA	TH	-
	Vertical Active Display Period	TVD	NA	(1080)	NA	TH	-
	Vertical Active Blanking Period	TVB	NA	(45)	NA	TH	-
	Horizontal Total Time	TH	NA	(2200)	NA	Tc	-
	Horizontal Active Display Period	THD	NA	(1920)	NA	Tc	-
	Horizontal Active Blanking Period	THB	NA	(280)	NA	Tc	-

Note (1) Because this module is operated by DE only mode, Hsync and Vsync are ignored.

INPUT SIGNAL TIMING DIAGRAM

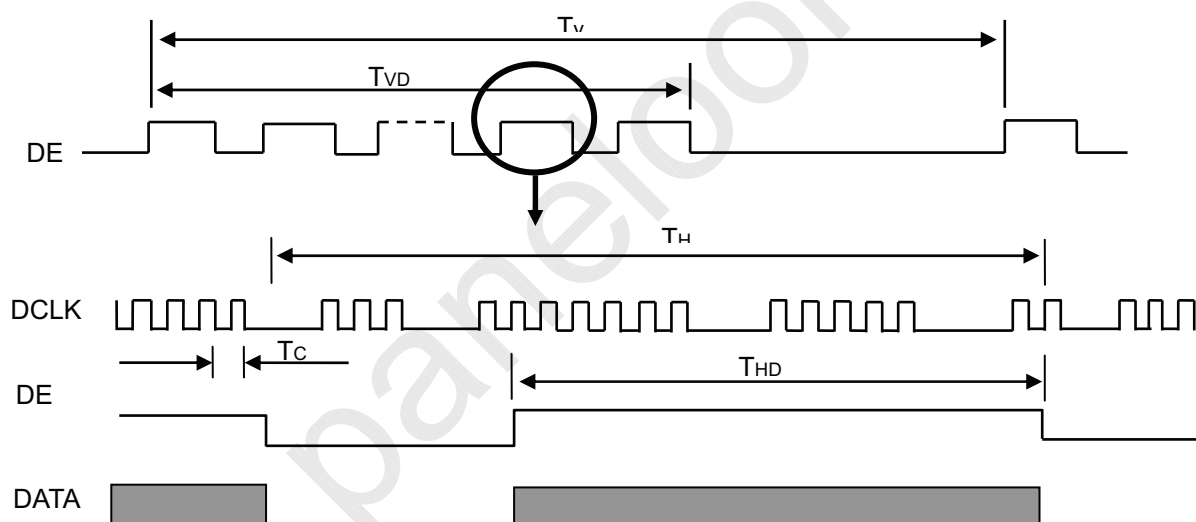

4.6 POWER ON/OFF SEQUENCE

The power sequence specifications are shown as the following table and diagram.

Symbol	Value			Unit	Note
	Min.	Typ.	Max.		
t1	0.5	-	10	ms	
t2	0	-	50	ms	
t3	0	-	50	ms	
t4	500	-	-	ms	
t5	200	-	-	ms	
t6	200	-	-	ms	
t7	0.5	-	10	ms	
t _A	0.5	-	10	ms	
t _B	0	-	10	ms	
t _C	10	-	-	ms	
t _D	10	-	-	ms	
t _E	10	-	-	ms	
t _F	10	-	-	ms	

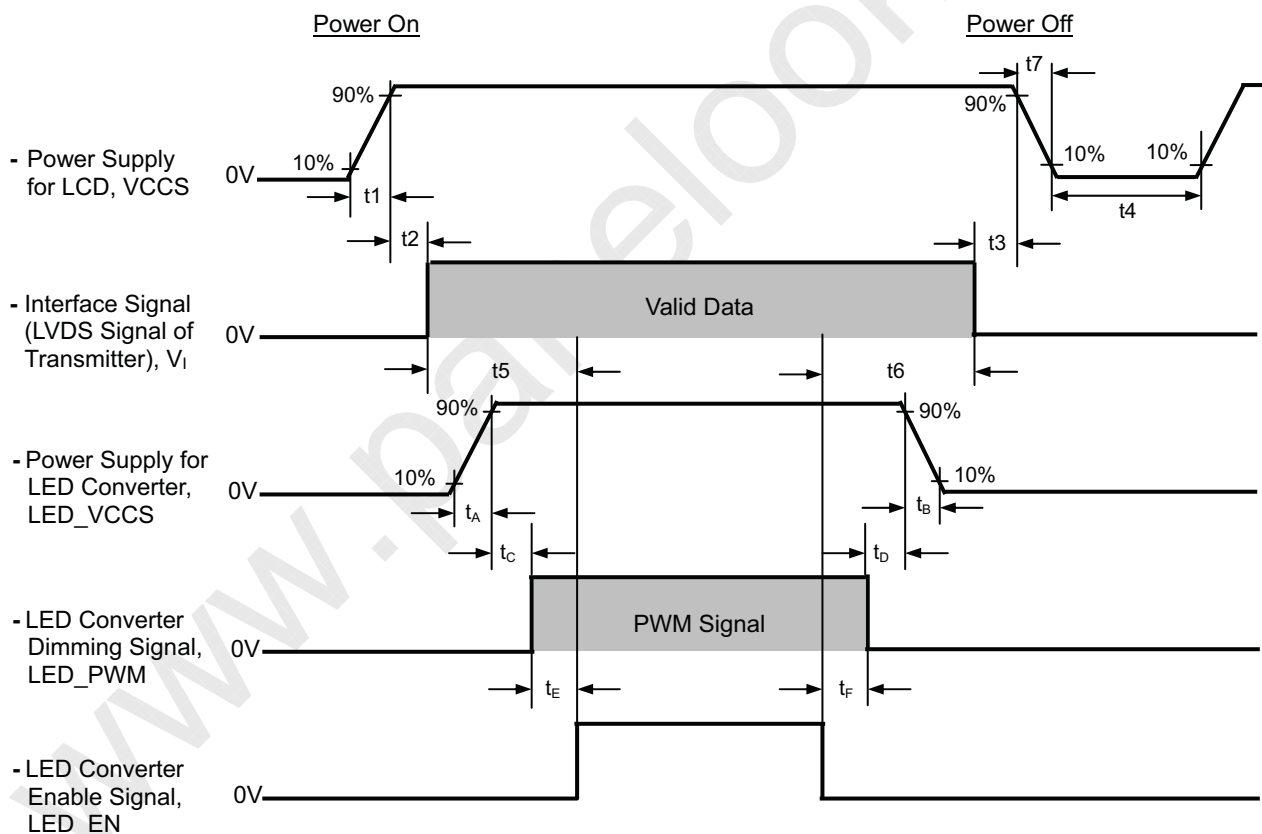

Note (1) Please don't plug or unplug the interface cable when system is turned on.

Note (2) Please avoid floating state of the interface signal during signal invalid period.

Note (3) It is recommended that the backlight power must be turned on after the power supply for LCD and the interface signal is valid.

5. OPTICAL CHARACTERISTICS

5.1 TEST CONDITIONS

Item	Symbol	Value	Unit
Ambient Temperature	Ta	25±2	°C
Ambient Humidity	Ha	50±10	%RH
Supply Voltage	V _{CC}	3.3	V
Input Signal	According to typical value in "3. ELECTRICAL CHARACTERISTICS"		
LED Light Bar Input Current	I _L	(252)	mA

The measurement methods of optical characteristics are shown in Section 5.2. The following items should be measured under the test conditions described in Section 5.1 and stable environment shown in Note (5).

5.2 OPTICAL SPECIFICATIONS

Item		Symbol	Condition	Min.	Typ.	Max.	Unit	Note	
Contrast Ratio		CR	$\theta_x=0^\circ, \theta_y=0^\circ$ Viewing Normal Angle	400	500	-	-	(2), (5),(7)	
Response Time		T _R		-	3	7	ms	(3),(7)	
		T _F		-	8	12	ms		
Average Luminance of White		L _{Ave}			255	300	-	cd/m ²	(4), (6),(7)
Color Chromaticity	Red	R _x		$\theta_x=0^\circ, \theta_y=0^\circ$ Viewing Normal Angle	Typ - 0.03	(0.653)	Typ + 0.03	-	(1),(7)
		R _y				(0.333)		-	
	Green	G _x				(0.324)		-	
		G _y				(0.630)		-	
	Blue	B _x				(0.155)		-	
		B _y				(0.037)		-	
	White	W _x	0.313			-			
W _y		0.329	-						
Viewing Angle	Horizontal	θ_{x+}	CR≥10	60	70	-	Deg.	(1),(5), (7)	
		θ_{x-}		60	70	-			
	Vertical	θ_{y+}		50	60	-			
		θ_{y-}		50	60	-			
White Variation of 5 Points		δW_{5p}	$\theta_x=0^\circ, \theta_y=0^\circ$	80	-	-	%	(5),(6), (7)	

Note (1) Definition of Viewing Angle (θ_x, θ_y)

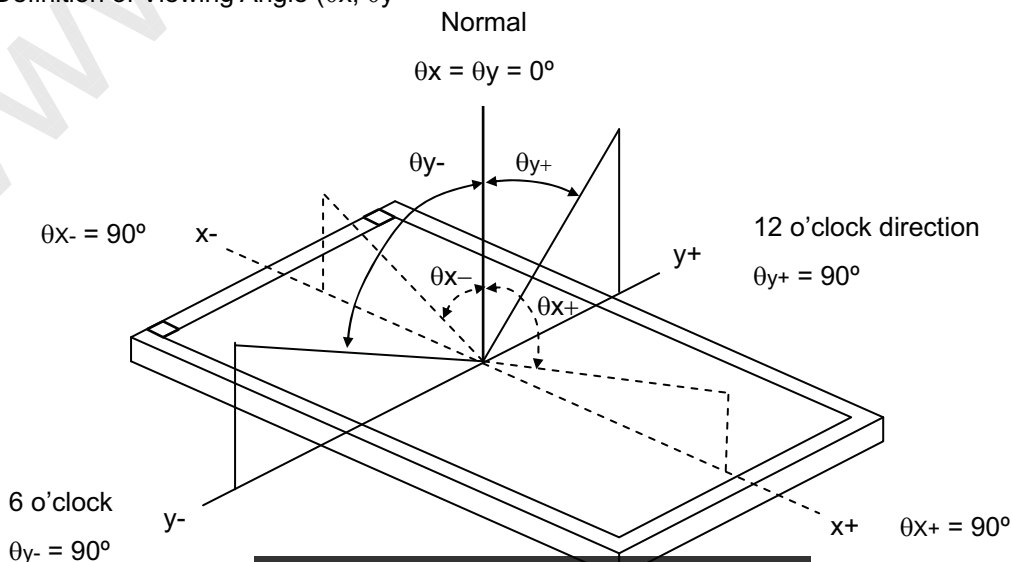

Note (2) Definition of Contrast Ratio (CR):

The contrast ratio can be calculated by the following expression.

$$\text{Contrast Ratio (CR)} = L_{63} / L_0$$

L63: Luminance of gray level 63

L 0: Luminance of gray level 0

$$\text{CR} = \text{CR} (1)$$

CR (X) is corresponding to the Contrast Ratio of the point X at Figure in Note (6).

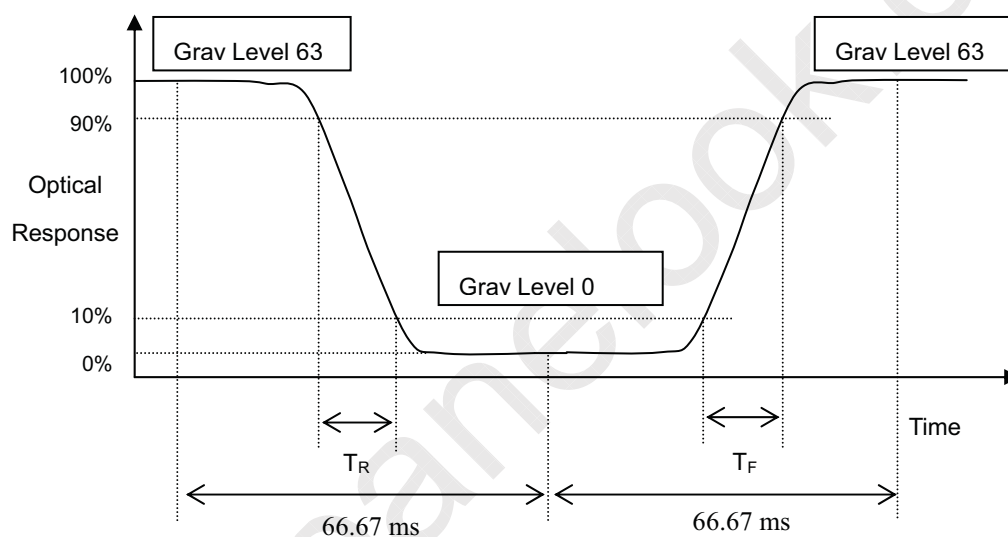
Note (3) Definition of Response Time (T_R , T_F):

Note (4) Definition of Average Luminance of White (L_{AVE}):

Measure the luminance of gray level 63 at 5 points

$$L_{AVE} = [L (1) + L (2) + L (3) + L (4) + L (5)] / 5$$

L (x) is corresponding to the luminance of the point X at Figure in Note (6)

Note (5) Measurement Setup:

The LCD module should be stabilized at given temperature for 20 minutes to avoid abrupt temperature change during measuring. In order to stabilize the luminance, the measurement should be executed after lighting Backlight for 20 minutes in a windless room.

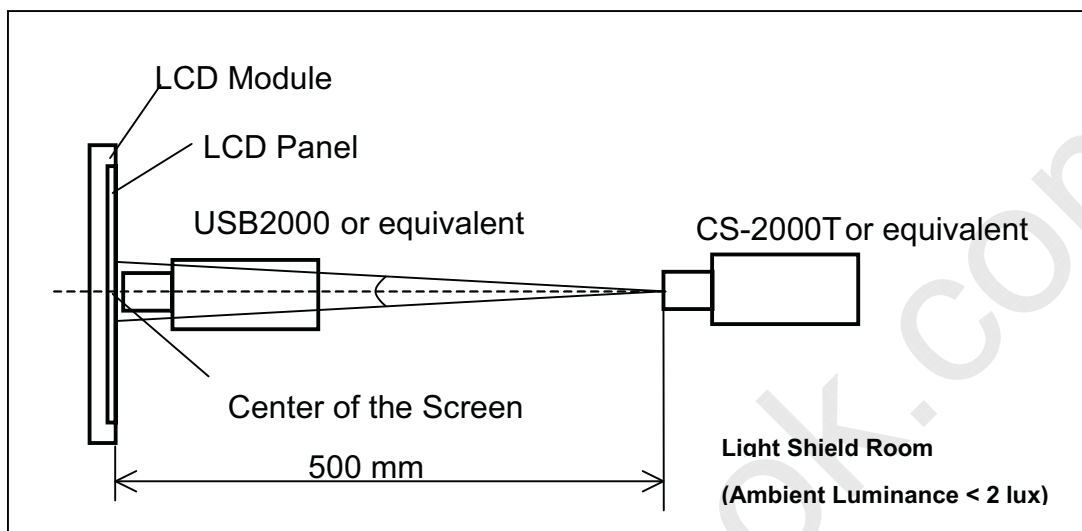
Note (6) Definition of White Variation (δW):

Measure the luminance of gray level 63 at 5 points

$$\delta W_{5p} = \{ \text{Minimum} [L(1) \sim L(5)] / \text{Maximum} [L(1) \sim L(5)] \} * 100\%$$

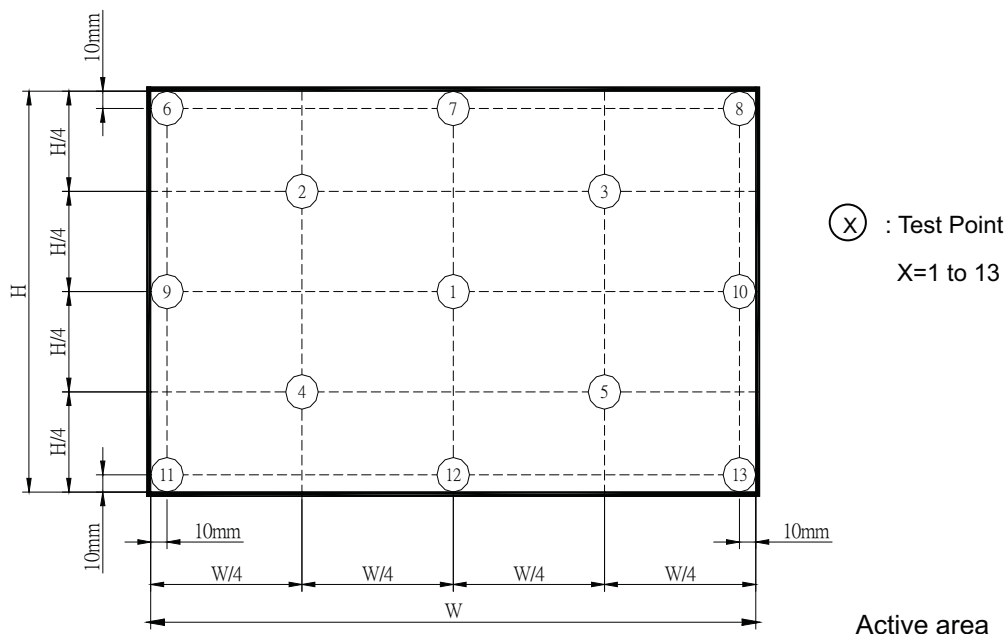

Note (7) The listed optical specifications refer to the initial value of manufacture, but the condition of the specifications after long-term operation will not be warranted.

6. RELIABILITY TEST ITEM

Test Item	Test Condition	Note
High Temperature Storage Test	60°C, 240 hours	(1) (2)
Low Temperature Storage Test	-20°C, 240 hours	
Thermal Shock Storage Test	-20°C, 0.5hour \longleftrightarrow 60°C, 0.5hour; 100cycles, 1hour/cycle	
High Temperature Operation Test	50°C, 240 hours	
Low Temperature Operation Test	0°C, 240 hours	
High Temperature & High Humidity Operation Test	50°C, RH 80%, 240hours	
ESD Test (Operation)	150pF, 330 Ω , 1sec/cycle Condition 1 : Contact Discharge, \pm 8KV Condition 2 : Air Discharge, \pm 15KV	(1)
Shock (Non-Operating)	220G, 2ms, half sine wave, 1 time for each direction of \pm X, \pm Y, \pm Z	(1)(3)
Vibration (Non-Operating)	1.5G / 10-500 Hz, Sine wave, 30 min/cycle, 1cycle for each X, Y, Z	(1)(3)

Note (1) criteria : Normal display image with no obvious non-uniformity and no line defect.

Note (2) Evaluation should be tested after storage at room temperature for more than two hour

Note (3) At testing Vibration and Shock, the fixture in holding the module has to be hard and rigid enough so that the module would not be twisted or bent by the fixture.

7. PACKING

7.1 MODULE LABEL

The barcode nameplate is pasted on each module as illustration, and its definitions are as following explanation.

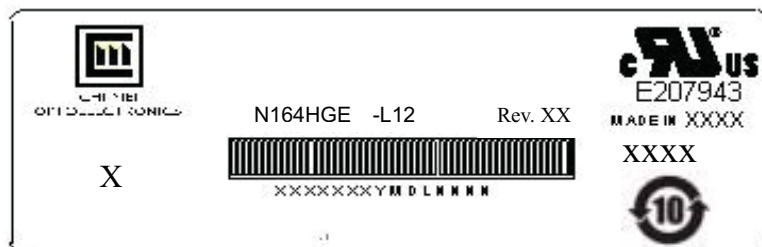

- (a) Model Name: N164HGE - L12
 (b) Revision: Rev. XX, for example: C1, C2 ...etc.
 (c) Serial ID: XXXXXXYMDLNNN

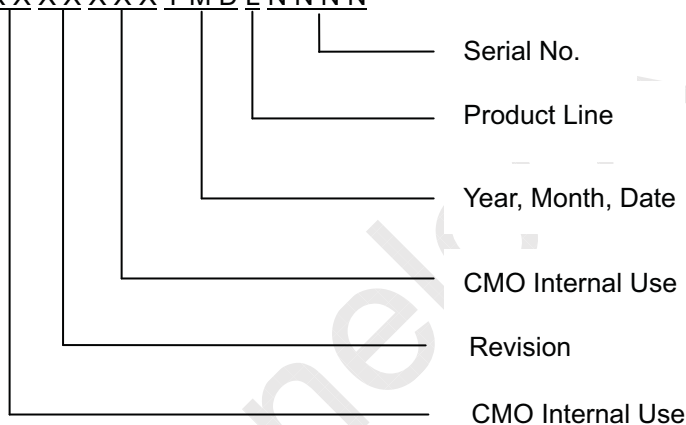

Serial ID includes the information as below:

- (a) Manufactured Date: Year: 0~9, for 2010~2019
 Month: 1~9, A~C, for Jan. ~ Dec.
 Day: 1~9, A~Y, for 1st to 31st, exclude I, O and U
- (b) Revision Code: cover all the change
- (c) Serial No.: Manufacturing sequence of product
- (d) Product Line: 1 -> Line1, 2 -> Line 2, ...etc.

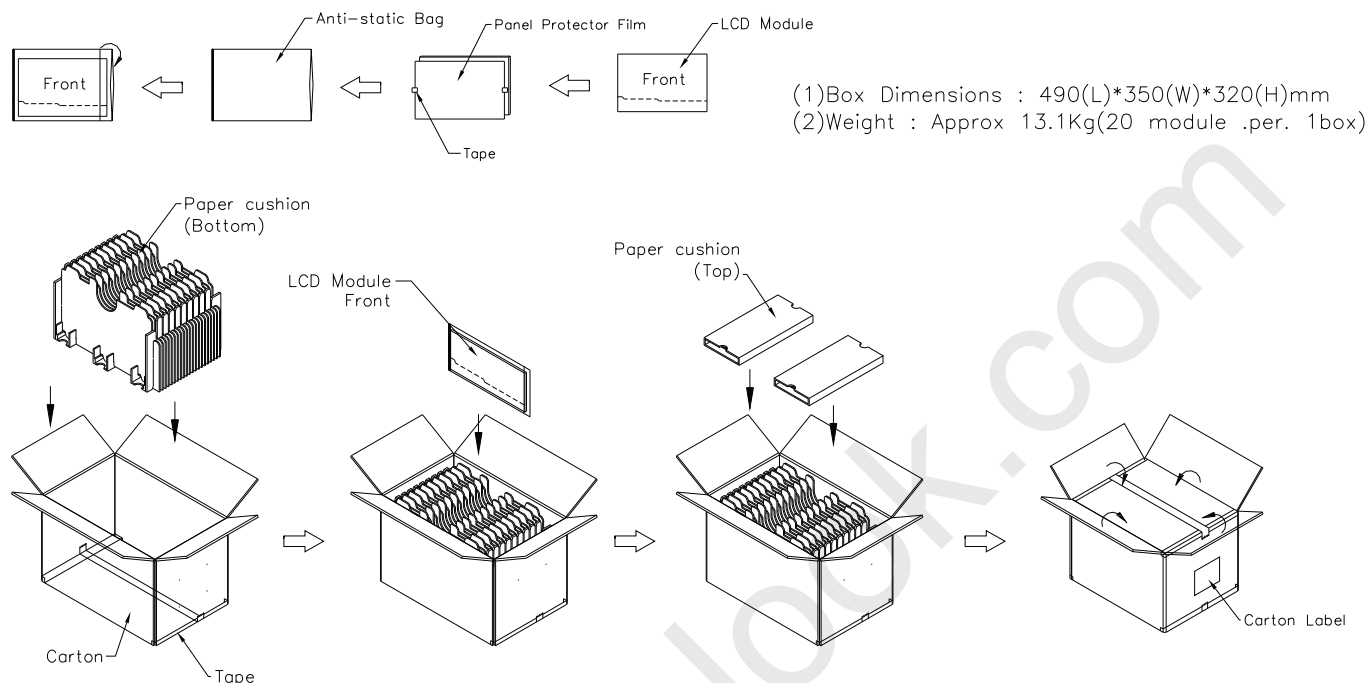
7.2 CARTON

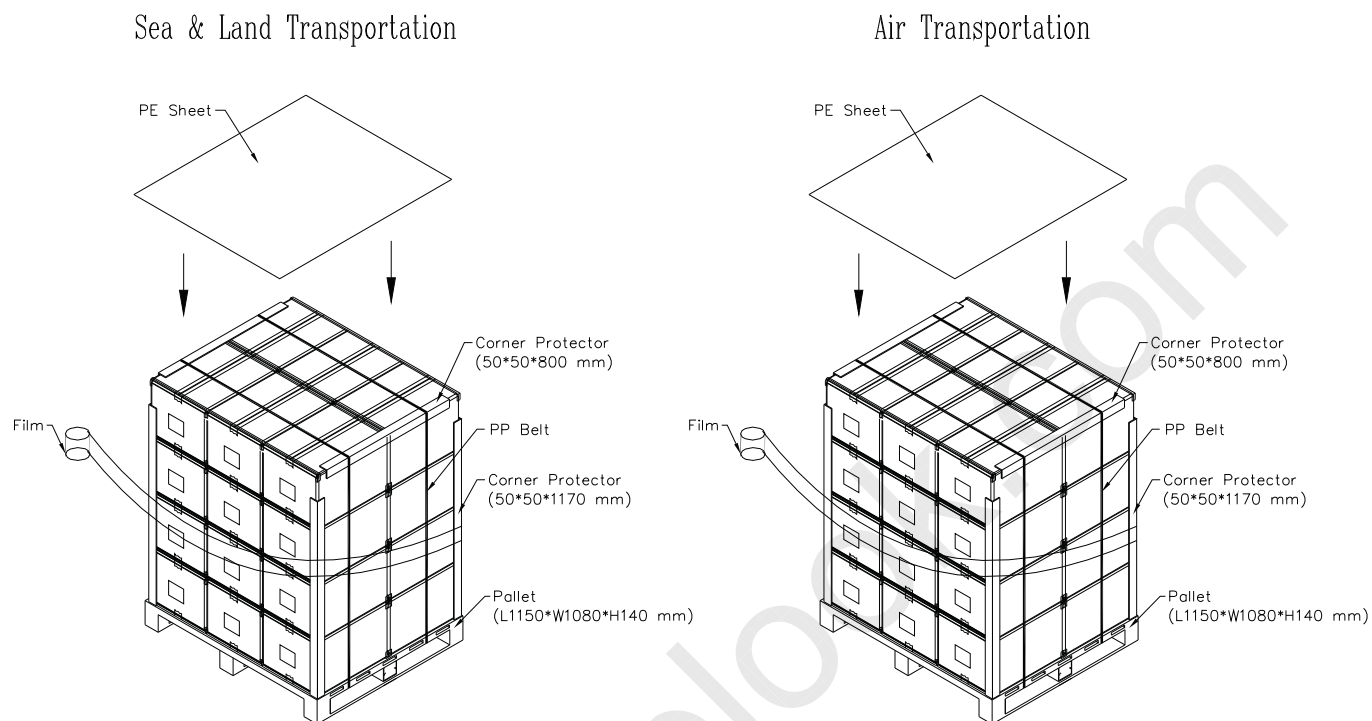
Figure. 7-2 Packing method

7.3 PALLET**Figure. 7-3 Packing method**

8. PRECAUTIONS

8.1 HANDLING PRECAUTIONS

- (1) The module should be assembled into the system firmly by using every mounting hole. Be careful not to twist or bend the module.
- (2) While assembling or installing modules, it can only be in the clean area. The dust and oil may cause electrical short or damage the polarizer.
- (3) Use fingerstalls or soft gloves in order to keep display clean during the incoming inspection and assembly process.
- (4) Do not press or scratch the surface harder than a HB pencil lead on the panel because the polarizer is very soft and easily scratched.
- (5) If the surface of the polarizer is dirty, please clean it by some absorbent cotton or soft cloth. Do not use Ketone type materials (ex. Acetone), Ethyl alcohol, Toluene, Ethyl acid or Methyl chloride. It might permanently damage the polarizer due to chemical reaction.
- (6) Wipe off water droplets or oil immediately. Staining and discoloration may occur if they left on panel for a long time.
- (7) If the liquid crystal material leaks from the panel, it should be kept away from the eyes or mouth. In case of contacting with hands, legs or clothes, it must be washed away thoroughly with soap.
- (8) Protect the module from static electricity, it may cause damage to the C-MOS Gate Array IC.
- (9) Do not disassemble the module.
- (10) Do not pull or fold the LED wire.
- (11) Pins of I/F connector should not be touched directly with bare hands.

8.2 STORAGE PRECAUTIONS

- (1) High temperature or humidity may reduce the performance of module. Please store LCD module within the specified storage conditions.
- (2) It is dangerous that moisture come into or contacted the LCD module, because the moisture may damage LCD module when it is operating.
- (3) It may reduce the display quality if the ambient temperature is lower than 10 °C. For example, the response time will become slowly, and the starting voltage of LED will be higher than the room temperature.

8.3 OPERATION PRECAUTIONS

- (1) Do not pull the I/F connector in or out while the module is operating.
- (2) Always follow the correct power on/off sequence when LCD module is connecting and operating. This can prevent the CMOS LSI chips from damage during latch-up.
- (3) The startup voltage of Backlight is approximately 1000 Volts. It may cause electrical shock while assembling with converter. Do not disassemble the module or insert anything into the Backlight unit.

Appendix. EDID DATA STRUCTURE

The EDID (Extended Display Identification Data) data formats are to support displays as defined in the VESA Plug & Display and FPD standards.

Byte # (decimal)	Byte # (hex)	Field Name and Comments	Value (hex)	Value (binary)
0	0	Header	00	00000000
1	1	Header	FF	11111111
2	2	Header	FF	11111111
3	3	Header	FF	11111111
4	4	Header	FF	11111111
5	5	Header	FF	11111111
6	6	Header	FF	11111111
7	7	Header	00	00000000
8	8	EISA ID manufacturer name ("CMI")	0D	00001101
9	9	EISA ID manufacturer name (Compressed ASCII)	AF	10101111
10	0A	ID product code (N164HGE-L12)	01	00000001
11	0B	ID product code (hex LSB first; N164HGE-L12)	16	00010110
12	0C	ID S/N (fixed "0")	00	00000000
13	0D	ID S/N (fixed "0")	00	00000000
14	0E	ID S/N (fixed "0")	00	00000000
15	0F	ID S/N (fixed "0")	00	00000000
16	10	Week of manufacture (fixed week code)	05	00000101
17	11	Year of manufacture (fixed year code)	15	00010101
18	12	EDID structure version # ("1")	01	00000001
19	13	EDID revision # ("3")	03	00000011
20	14	Video I/P definition ("digital")	80	10000000
21	15	Max H image size ("37.4cm")	25	00100101
22	16	Max V image size ("19.260cm")	13	00010011
23	17	Display Gamma (Gamma = "2.2")	78	01111000
24	18	Feature support ("Active off, RGB Color")	0A	00001010
25	19	Rx1, Rx0, Ry1, Ry0, Gx1, Gx0, Gy1, Gy0	CF	11001111
26	1A	Bx1, Bx0, By1, By0, Wx1, Wx0, Wy1, Wy0	45	01000101
27	1B	Rx=0.565	90	10010000
28	1C	Ry=0.348	59	01011001
29	1D	Gx=0.343	57	01010111
30	1E	Gy=0.585	95	10010101
31	1F	Bx=0.161	29	00101001
32	20	By=0.121	1F	00011111
33	21	Wx=0.313	50	01010000
34	22	Wy=0.329	54	01010100
35	23	Established timings 1	00	00000000
36	24	Established timings 2	00	00000000
37	25	Manufacturer's reserved timings	00	00000000
38	26	Standard timing ID # 1	01	00000001
39	27	Standard timing ID # 1	01	00000001
40	28	Standard timing ID # 2	01	00000001
41	29	Standard timing ID # 2	01	00000001

42	2A	Standard timing ID # 3	01	00000001
43	2B	Standard timing ID # 3	01	00000001
44	2C	Standard timing ID # 4	01	00000001
45	2D	Standard timing ID # 4	01	00000001
46	2E	Standard timing ID # 5	01	00000001
47	2F	Standard timing ID # 5	01	00000001
48	30	Standard timing ID # 6	01	00000001
49	31	Standard timing ID # 6	01	00000001
50	32	Standard timing ID # 7	01	00000001
51	33	Standard timing ID # 7	01	00000001
52	34	Standard timing ID # 8	01	00000001
53	35	Standard timing ID # 8	01	00000001
54	36	Detailed timing description # 1 Pixel clock (150.10MHz", According to VESA CVT Rev1.1)	A2	10100010
55	37	# 1 Pixel clock (hex LSB first)	3B	00111011
56	38	# 1 H active ("1920")	80	10000000
57	39	# 1 H blank ("302")	2E	00101110
58	3A	# 1 H active : H blank ("1920 : 302")	71	01110001
59	3B	# 1 V active ("1080")	38	00111000
60	3C	# 1 V blank ("65")	41	01000001
61	3D	# 1 V active : V blank ("768 :12")	40	01000000
62	3E	# 1 H sync offset ("91")	5B	01011011
63	3F	# 1 H sync pulse width ("60")	3C	00111100
64	40	# 1 V sync offset : V sync pulse width ("6 : 10")	6A	01101010
65	41	# 1 H sync offset : H sync pulse width : V sync offset : V sync width ("91: 60 : 6 : 10")	00	00000000
66	42	# 1 H image size ("374 mm")	76	01110110
67	43	# 1 V image size ("192 mm")	C0	11000000
68	44	# 1 H image size : V image size ("374 : 192")	10	00010000
69	45	# 1 H boarder ("0")	00	00000000
70	46	# 1 V boarder ("0")	00	00000000
71	47	# 1 Non-interlaced, Normal, no stereo, Separate sync, H/V pol Negatives	18	00011000
72	48	Detailed timing description # 2 Pixel clock ("121.71MHz", According to VESA CVT Rev1.1)	8B	10001010
73	49	# 1 Pixel clock (hex LSB first)	2F	00101111
74	4A	# 2 H active ("1920")	80	10000000
75	4B	# 2 H blank ("263")	07	00000111
76	4C	# 2 H active : H blank ("1920 : 263")	71	01110001
77	4D	# 2 V active ("1080")	38	00111000
78	4E	# 2 V blank ("35")	23	00100011
79	4F	# 2 V active : V blank ("1080 :35")	40	01000000
80	50	# 2 H sync offset ("43")	2B	00101011
81	51	# 2 H sync pulse width ("66")	42	01000010
82	52	# 2 V sync offset : V sync pulse width ("7 : 7")	77	01110111
83	53	# 2 H sync offset : H sync pulse width : V sync offset : V sync width ("43: 66 : 7 : 7")	00	00000000
84	54	# 1 H image size ("374 mm")	76	01110110
85	55	# 1 V image size ("192 mm")	C0	11000000

86	56	# 1 H image size : V image size ("374 : 192")	10	00010000
87	57	# 1 H boarder ("0")	00	00000000
88	58	# 1 V boarder ("0")	00	00000000
89	59	# 1 Non-interlaced, Normal, no stereo, Separate sync, H/V pol Negatives	18	00011000
90	5A	Detailed timing description # 3 Pixel clock ("121.64MHz", According to VESA CVT Rev1.1)	84	10001010
91	5B	# 1 Pixel clock (hex LSB first)	2F	00101111
92	5C	# 2 H active ("1920")	80	10000000
93	5D	# 2 H blank ("688")	B0	00000111
94	5E	# 2 H active : H blank ("1920 : 688")	72	01110001
95	5F	# 2 V active ("1080")	38	00111000
96	60	# 2 V blank ("86")	56	00100011
97	61	# 2 V active : V blank ("1080 :86")	40	01000000
98	62	# 2 H sync offset ("85")	55	00101011
99	63	# 2 H sync pulse width ("130")	82	01000010
100	64	# 2 V sync offset : V sync pulse width ("13 : 13")	DD	01110111
101	65	# 2 H sync offset : H sync pulse width : V sync offset : V sync width ("85: 130 : 13 : 13")	00	00000000
102	66	# 1 H image size ("374 mm")	76	01110110
103	67	# 1 V image size ("192 mm")	C0	11000000
104	68	# 1 H image size : V image size ("374 : 192")	10	00010000
105	69	# 1 H boarder ("0")	00	00000000
106	6A	# 1 V boarder ("0")	00	00000000
107	6B	# 1 Non-interlaced, Normal, no stereo, Separate sync, H/V pol Negatives	18	00011000
108	6C	Detailed timing description # 4	00	00000000
109	6D	# 4 Flag	00	00000000
110	6E	# 4 Reserved	00	00000000
111	6F	# 4 FE (hex) defines ASCII string (Model Name"N164HGE-L12", ASCII)	FE	11111110
112	70	# 4 Flag	00	00000000
113	71	# 2 1st character of name ("N")	4E	01001110
114	72	# 2 2nd character of name ("1")	31	00110001
115	73	# 2 3rd character of name ("6")	36	00110110
116	74	# 2 4th character of name ("4")	34	00110100
117	75	# 2 5th character of name ("H")	48	01001000
118	76	# 2 6th character of name ("G")	47	01000111
119	77	# 2 7th character of name ("E")	45	01000101
120	78	# 2 8th character of name ("-")	2D	00101101
121	79	# 2 9th character of name ("L")	4C	01001100
122	7A	# 2 Ath character of name ("1")	31	00110001
123	7B	# 2 Bth character of name ("2")	32	00110010
124	7C	# 2 New line character indicates end of ASCII string	0A	00001010
125	7D	# 4 Padding with "Blank" character	20	00100000
126	7E	Extension flag	00	00000000
127	7F	Checksum	5D	01011101

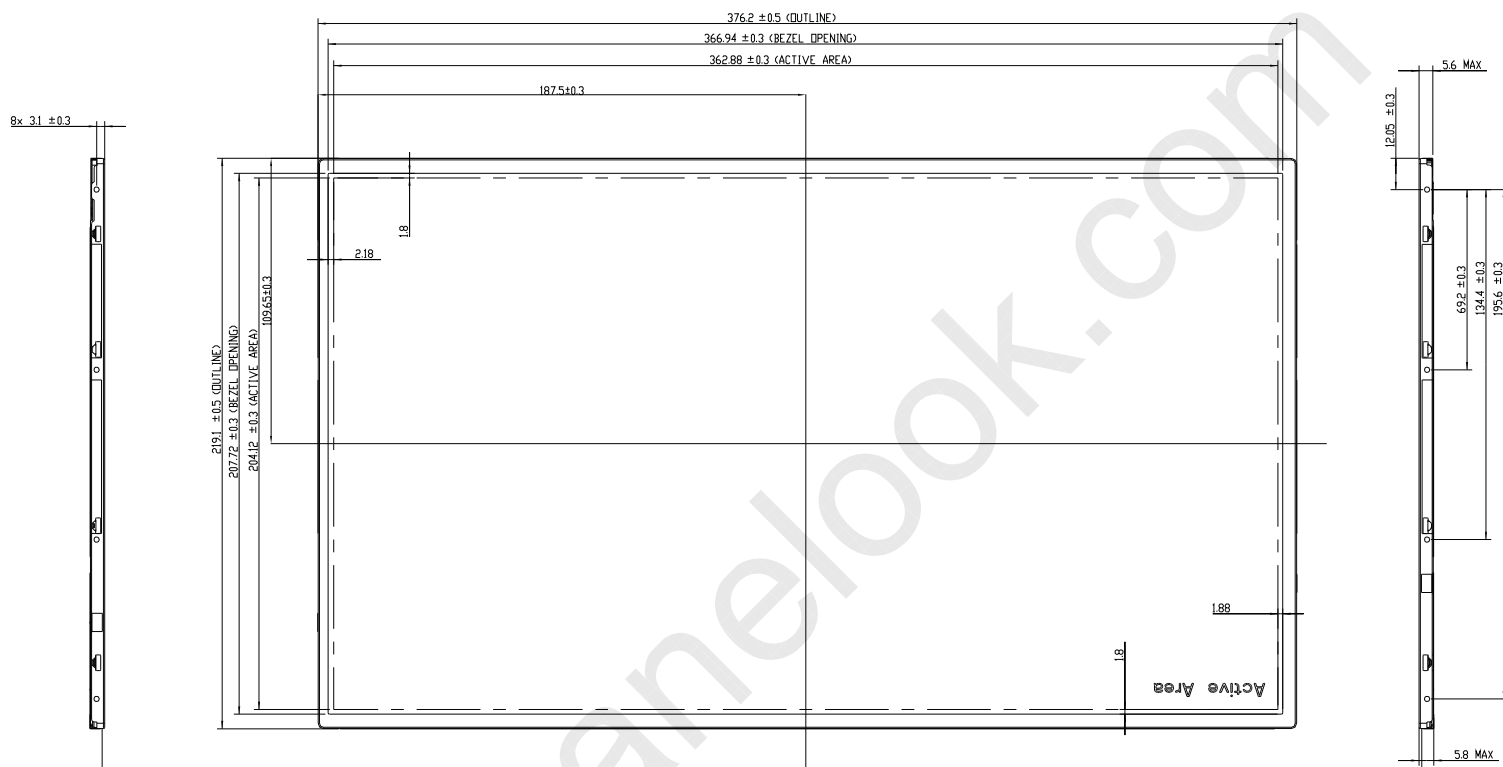
Appendix. OUTLINE DRAWING

NOTES:

1. Max screw length: 2.5mm.
2. Screw torque: 2.3~2.5 kgf-cm.
3. LCD module input connector: I-PEX 20455-040E-12
4. Gap between bezel and panel: 0.5mm MAX.
5. In order to avoid abnormal display, pooling and white spot, no overlapping is suggested at cables, antennas, camera, WLAN, WAN or other foreign objects over CDF driver IC, TCON and VR locations.
6. Max module flatness: 0.5mm.
7. X, Y MARKS THE REFERENCE DIMENSIONS.

