





**TFT LCD Approval Specification**

**MODEL NO.: N170C1 - L02**

Customer : \_\_\_\_\_

Approved by : \_\_\_\_\_

Note :

| Liquid Crystal Display Division   |   |
|---|---|
| QRA Division.   | OA Head Division.   |
| Approval  | Approval  |
|  |  |

## - CONTENTS -

|   |       |    |
|---|-------|----|
| REVISION HISTORY                        | ----- | 3  |
| 1. GENERAL DESCRIPTION                  | ----- | 4  |
| 1.1 OVERVIEW                            |       |    |
| 1.2 FEATURES                            |       |    |
| 1.3 APPLICATION                         |       |    |
| 1.4 GENERAL SPECIFICATIONS              |       |    |
| 1.5 MECHANICAL SPECIFICATIONS           |       |    |
| 2. ABSOLUTE MAXIMUM RATINGS             | ----- | 5  |
| 2.1 ABSOLUTE RATINGS OF ENVIRONMENT     |       |    |
| 2.2 ELECTRICAL ABSOLUTE RATINGS         |       |    |
| 2.2.1 TFT LCD MODULE                    |       |    |
| 2.2.2 BACKLIGHT UNIT                    |       |    |
| 3. ELECTRICAL CHARACTERISTICS           | ----- | 6  |
| 3.1 TFT LCD MODULE                      |       |    |
| 3.2 BACKLIGHT UNIT                      |       |    |
| 4. BLOCK DIAGRAM                        | ----- | 11 |
| 4.1 TFT LCD MODULE                      |       |    |
| 4.2 BACKLIGHT UNIT                      |       |    |
| 5. INPUT TERMINAL PIN ASSIGNMENT        | ----- | 12 |
| 5.1 TFT LCD MODULE                      |       |    |
| 5.2 BACKLIGHT UNIT                      |       |    |
| 5.3 TIMING DIAGRAM OF LVDS INPUT SIGNAL |       |    |
| 5.4 COLOR DATA INPUT ASSIGNMENT         |       |    |
| 5.5 EDID CODE DATA STRUCTURE            |       |    |
| 5.6 EDID SIGNAL SPECIFICATION           |       |    |
| 6. INTERFACE TIMING                     | ----- | 15 |
| 6.1 INPUT SIGNAL TIMING SPECIFICATIONS  |       |    |
| 6.2 POWER ON/OFF SEQUENCE               |       |    |
| 7. OPTICAL CHARACTERISTICS              | ----- | 17 |
| 7.1 TEST CONDITIONS                     |       |    |
| 7.2 OPTICAL SPECIFICATIONS              |       |    |
| 8. PRECAUTIONS                          | ----- | 21 |
| 8.1 ASSEMBLY AND HANDLING PRECAUTIONS   |       |    |
| 8.2 SAFETY PRECAUTIONS                  |       |    |
| 9. PACKING                              | ----- | 22 |
| 9.1 CARTON                              |       |    |
| 9.2 PALLET                              |       |    |
| 10. DEFINITION OF LABELS                | ----- | 24 |
| 10.1 CMO MODULE LABEL                   |       |    |
| 10.2 CMO CARTON LABEL                   |       |    |

### REVISION HISTORY

| Version | Date         | Page (New) | Section | Description   |
|---------|--------------|------------|---------|---|
| Ver 1.1 | June 24,2005 | All        | All     | Preliminary Specification V1.1 was first issued   |
| Ver 2.0 | July 21,2005 | P5         | 2.2     | Change the BL Max lamp current from 7.0 mA to 6.5mA   |
|         |              | P8         | 3.2     | Change BL Power consumption from 9.42W to 9.12W   |
|         |              | P11        | 5.1     | "Connector part no" delete "Equivalent"   |
|         |              | P21        | 7.2     | Change the "definition of Average Luminance of White ( $L_{AVE}$ )" from "5 points" to "Center point" |
|         |              |            |         | Change the contrast typical value from 600 to 550; min value from 450 to 400                          |
|         |              |            |         | Rx change from 0.644 to 0.643   |
|         |              |            |         | Ry change from 0.348 to 0.349   |
|         |              |            |         | Gx change from 0.285 to 0.283   |
|         |              |            |         | By change from 0.072 to 0.074   |

## 1. GENERAL DESCRIPTION

### 1.1 OVERVIEW

N170C1 - L02 is a 17.0" TFT Liquid Crystal Display module with two CCFLs Backlight unit and 30 pins LVDS interface. This module supports 1440 x 900 Wide-XGA mode and can display 262,144 colors. The optimum viewing angle is at 6 o'clock direction. The inverter module for Backlight is not built in.

### 1.2 FEATURES

- Thin and High Brightness
- WXGA (1440 x 900 pixels) resolution
- DE only mode
- 3.3V LVDS (Low Voltage Differential Signaling) interface with 2 pixel/clock
- 2 CCFLs

### 1.3 APPLICATION

- TFT LCD Notebook

### 1.4 GENERAL SPECIFICATIONS

| Item               | Specification                          | Unit  | Note |
|--------------------|--|-------|------|
| Active Area        | 367.2 (H) x 229.5 (V) (17.0" diagonal) | mm    | (1)  |
| Bezel Opening Area | 371.2 (H) x 233.5 (V)                  | mm    |      |
| Driver Element     | a-si TFT active matrix                 | -     | -    |
| Pixel Number       | 1440 x R.G.B. x 900                    | pixel | -    |
| Pixel Pitch        | 0.255 (H) x 0.255 (V)                  | mm    | -    |
| Pixel Arrangement  | RGB vertical stripe                    | -     | -    |
| Display Colors     | 262,144                                | color | -    |
| Transmissive Mode  | Normally white                         | -     | -    |
| Surface Treatment  | Hard coating (2H), Glare Type          | -     | -    |

### 1.5 MECHANICAL SPECIFICATIONS

| Item        | Min.           | Typ.  | Max.    | Unit     | Note |     |
|-------------|----------------|-------|---------|----------|------|-----|
| Module Size | Horizontal (H) | 381.7 | 382.2   | 382.7    | mm   | (1) |
|             | Vertical (V)   | 246.3 | 246.8   | 247.3    | mm   |     |
|             | Depth (D)      | ---   | 9.7~8.3 | 10.0~8.6 | mm   |     |
| Weight      | ---            | 950   | 980     | g        | -    |     |

Note (1) Please refer to the attached drawings for more information of front and back outline dimensions.

## 2. ABSOLUTE MAXIMUM RATINGS

### 2.1 ABSOLUTE RATINGS OF ENVIRONMENT

| Item                          | Symbol           | Value |      | Unit | Note     |
|-------------------------------|------------------|-------|------|------|----------|
|                               |                  | Min.  | Max. |      |          |
| Storage Temperature           | T <sub>ST</sub>  | -20   | +60  | °C   | (1)      |
| Storage Humidity              | H <sub>ST</sub>  | 5     | 90   |      | (1)      |
| Operating Ambient Temperature | T <sub>OP</sub>  | 0     | +50  | °C   | (1), (2) |
| Operating Humidity            | H <sub>OP</sub>  | 20    | 90   |      | (1)      |
| Shock (Non-Operating)         | H <sub>ST</sub>  | -     | 200  | G    | (3), (5) |
| Vibration (Non-Operating)     | V <sub>NOP</sub> | -     | 1.5  | G    | (4), (5) |

Note (1) Temperature and relative humidity range is shown below.

(a) 90 %RH Max. (T<sub>a</sub> ≤ 40 °C).

(b) Wet-bulb temperature should be 39 °C Max. (T<sub>a</sub> > 40 °C).

(c) No condensation.

Note (2) The ambient temperature means the temperature of panel surface.

Note (3) 2ms, half sine wave, 1 times for ± X, ± Y, ± Z.

Note (4) 10 ~ 500 Hz, 30 min/cycle, 1 cycles for each X, Y, Z axis. The fixing condition is shown as below:

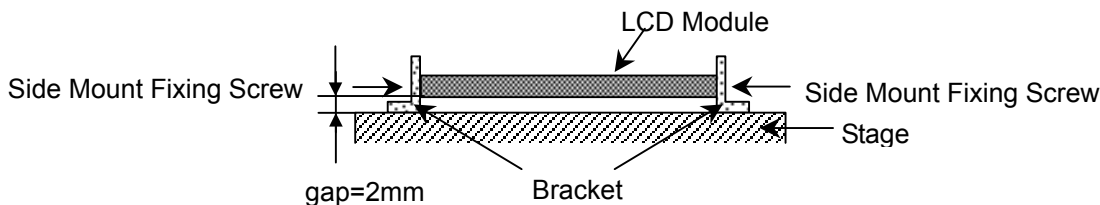

Note (5) At testing Vibration and Shock, the fixture in holding the module has to be hard and rigid enough so that the module would not be twisted or bent by the fixture.

### 2.2 ELECTRICAL ABSOLUTE RATINGS

#### 2.2.1 TFT LCD MODULE

| Item                 | Symbol          | Value |                      | Unit | Note |
|----------------------|-----------------|-------|----------------------|------|------|
|                      |                 | Min.  | Max.                 |      |      |
| Power Supply Voltage | V <sub>CC</sub> | -0.3  | +4.0                 | V    | (1)  |
| Logic Input Voltage  | V <sub>IN</sub> | -0.3  | V <sub>CC</sub> +0.3 | V    |      |

#### 2.2.2 BACKLIGHT UNIT

| Item           | Symbol         | Value |      | Unit              | Note                              |
|----------------|----------------|-------|------|-------------------|-----------------------------------|
|                |                | Min.  | Max. |                   |                                   |
| Lamp Voltage   | V <sub>L</sub> | —     | 2.5K | V <sub>RMS</sub>  | (1), (2), I <sub>L</sub> = 6.0 mA |
| Lamp Current   | I <sub>L</sub> | —     | 6.5  | mA <sub>RMS</sub> |                                   |
| Lamp Frequency | F <sub>L</sub> | —     | 80   | KHz               |                                   |

Note (1) Permanent damage to the device may occur if maximum values are exceeded. Function operation should be restricted to the conditions described under Normal Operating Conditions.

Note (2) Specified values are for lamp (Refer to 3.2 for further information).

### 3. ELECTRICAL CHARACTERISTICS

#### 3.1 TFT LCD MODULE

Ta = 25 ± 2 °C

| Parameter             | Symbol            | Value           |      |      | Unit | Note |      |
|-----------------------|-------------------|-----------------|------|------|------|------|------|
|                       |                   | Min.            | Typ. | Max. |      |      |      |
| Power Supply Voltage  | V <sub>CC</sub>   | 3.0             | 3.3  | 3.6  | V    | -    |      |
| Ripple Voltage        | V <sub>RP</sub>   |                 | 50   |      | mV   | -    |      |
| Rush Current          | I <sub>RUSH</sub> |                 | 0.5  |      | A    | (2)  |      |
| Power Supply Current  | White             | L <sub>CC</sub> |      | 450  | 480  | mA   | (3)a |
|                       | Black             |                 |      | 570  | 600  | mA   | (3)b |
| Logical Input Voltage | "H" Level         | V <sub>IL</sub> |      |      | +100 | mV   | -    |
|                       | "L" Level         | V <sub>IH</sub> | -100 |      |      | mV   | -    |
| Terminating Resistor  | R <sub>T</sub>    |                 | 100  |      | Ohm  |      |      |

Note (1) The module should be always operated within above ranges.

Note (2) Measurement Conditions:

:

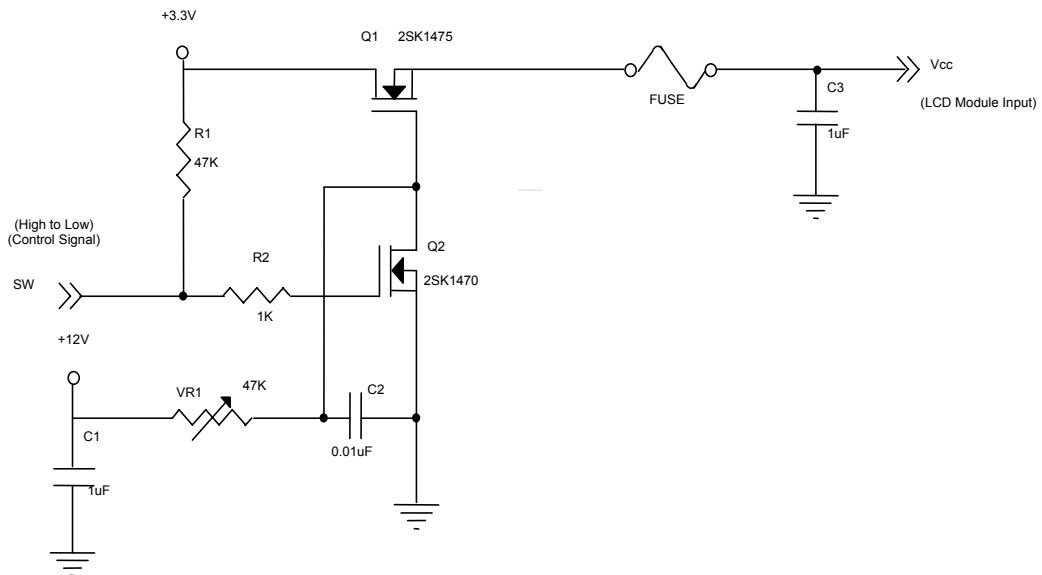

**Vcc rising time is 470us**

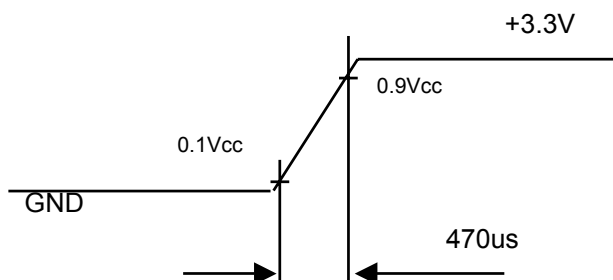

Note (3) The specified power supply current is under the conditions at  $V_{cc} = 3.3\text{ V}$ ,  $T_a = 25 \pm 2\text{ }^\circ\text{C}$ ,  $f_v = 60\text{ Hz}$ , whereas a power dissipation check pattern below is displayed.

a. White Pattern

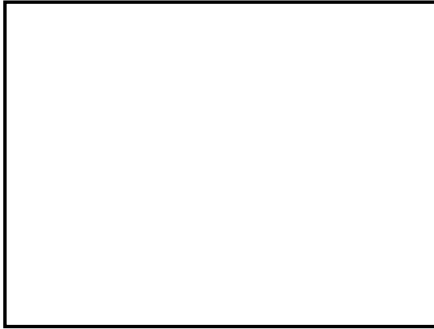

Active Area

b. Black Pattern

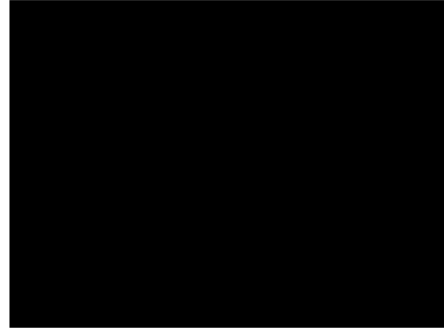

Active Area

### 3.2 BACKLIGHT UNIT

Ta = 25 ± 2 °C

| Parameter            | Symbol          | Value    |        |                | Unit              | Note                         |
|----------------------|-----------------|----------|--------|----------------|-------------------|------------------------------|
|                      |                 | Min.     | Typ.   | Max.           |                   |                              |
| Lamp Input Voltage   | V <sub>L</sub>  | (680)    | (760)  | (840)          | V <sub>RMS</sub>  | I <sub>L</sub> = 6.0 mA      |
| Lamp Current         | I <sub>L</sub>  | 2.0      | 6.0    | 6.5            | mA <sub>RMS</sub> | (1)                          |
| Lamp Turn On Voltage | V <sub>S</sub>  | —        | —      | (1620) (25 °C) | V <sub>RMS</sub>  | (2)                          |
|                      |                 | —        | —      | (1900) (0 °C)  | V <sub>RMS</sub>  | (2)                          |
| Operating Frequency  | F <sub>L</sub>  | 50       | —      | 80             | KHz               | (3)                          |
| Lamp Life Time       | L <sub>BL</sub> | (12,000) | —      | —              | Hrs               | (5)                          |
| Power Consumption    | P <sub>L</sub>  | —        | (9.12) | —              | W                 | (4), I <sub>L</sub> = 6.0 mA |

Note (1) Lamp current is measured by utilizing a high frequency current meter as shown below:

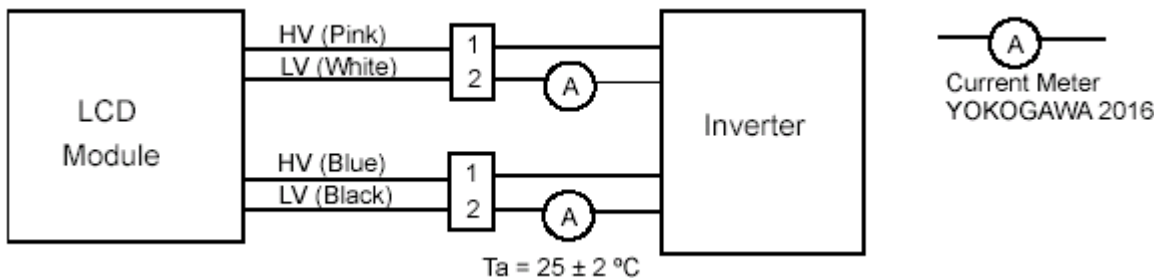

Note (2) The voltage shown above should be applied to the lamp for more than 1 second after startup. Otherwise the lamp may not be turned on.

Note (3) The lamp frequency may produce interference with horizontal synchronous frequency from the display, and this may cause line flow on the display. In order to avoid interference, the lamp frequency should be detached from the horizontal synchronous frequency and its harmonics as far as possible.

Note (4)  $P_L = I_L \times V_L \times 2$

Note (5) The lifetime of lamp can be defined as the time in which it continues to operate under the condition Ta = 25 ± 2 °C and I<sub>L</sub> = 6.0 mA<sub>RMS</sub> until one of the following events occurs:

- (a) When the brightness becomes or lower than 50% of its original value.
- (b) When the effective ignition length becomes or lower than 80% of its original value. (Effective ignition length is defined as an area that has less than 70% brightness compared to the brightness in the center point.)

Note (6) The waveform of the voltage output of inverter must be area-symmetric and the design of the inverter must have specifications for the modularized lamp. The performance of the Backlight, such as lifetime or brightness, is greatly influenced by the characteristics of the DC-AC inverter for the lamp. All the parameters of an inverter should be carefully designed to avoid generating too much current leakage from high voltage output of the inverter. When designing or ordering the inverter please make sure that a poor lighting caused by the mismatch of the Backlight and the inverter (miss-lighting, flicker, etc.) never occurs. If the above situation is confirmed, the module should be operated in the same manners when it is installed in your instrument.



The output of the inverter must have symmetrical (negative and positive) voltage waveform and symmetrical current waveform. (Unsymmetrical ratio is less than 10%) Please do not use the inverter, which has unsymmetrical voltage and unsymmetrical current and spike wave. Lamp frequency may produce interference with horizontal synchronous frequency and as a result this may cause beat on the display. Therefore lamp frequency shall be as away possible from the horizontal synchronous frequency and from its harmonics in order to prevent interference.

Requirements for a system inverter design, which is intended to have a better display performance, a better power efficiency and a more reliable lamp. It shall help increase the lamp lifetime and reduce its leakage current.

- a. The asymmetry rate of the inverter waveform should be 10% below;
- b. The distortion rate of the waveform should be within  $\sqrt{2} \pm 10\%$ ;
- c. The ideal sine wave form shall be symmetric in positive and negative polarities.

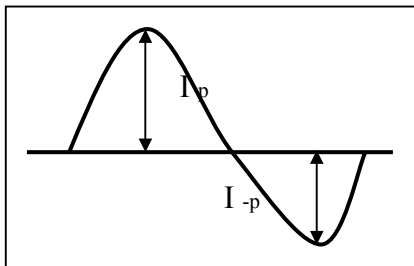

\* Asymmetry rate:

$$| I_p - I_{-p} | / I_{rms} * 100\%$$

\* Distortion rate

$$I_p \text{ (or } I_{-p}) / I_{rms}$$

#### 4. BLOCK DIAGRAM

##### 4.1 TFT LCD MODULE

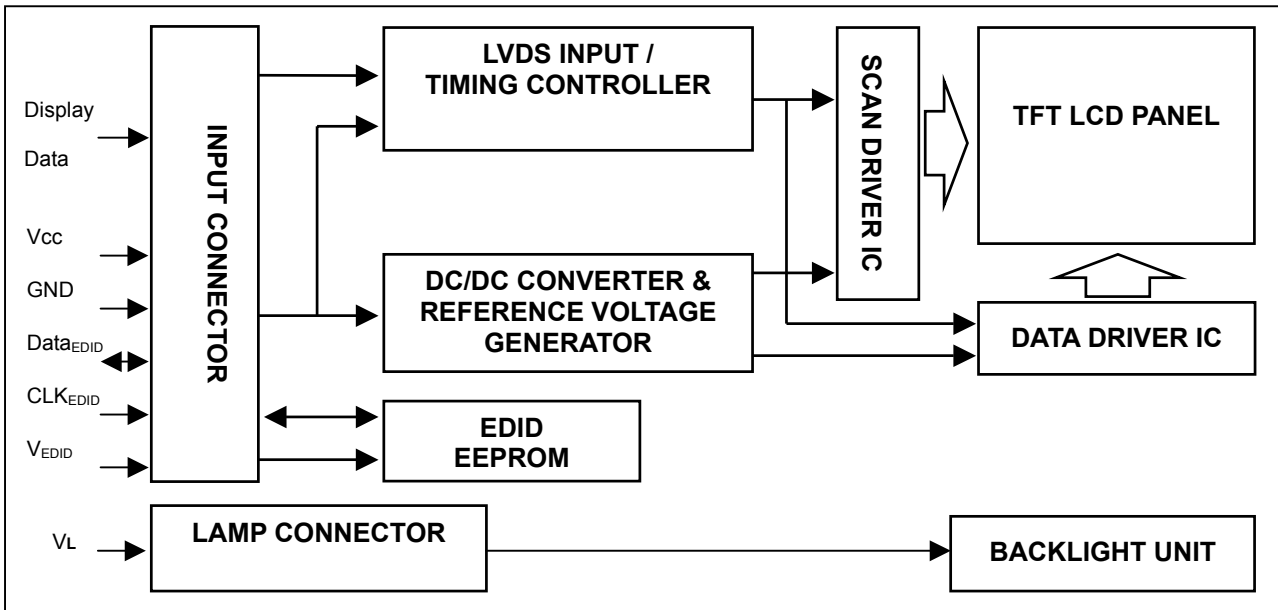

##### 4.2 BACKLIGHT UNIT

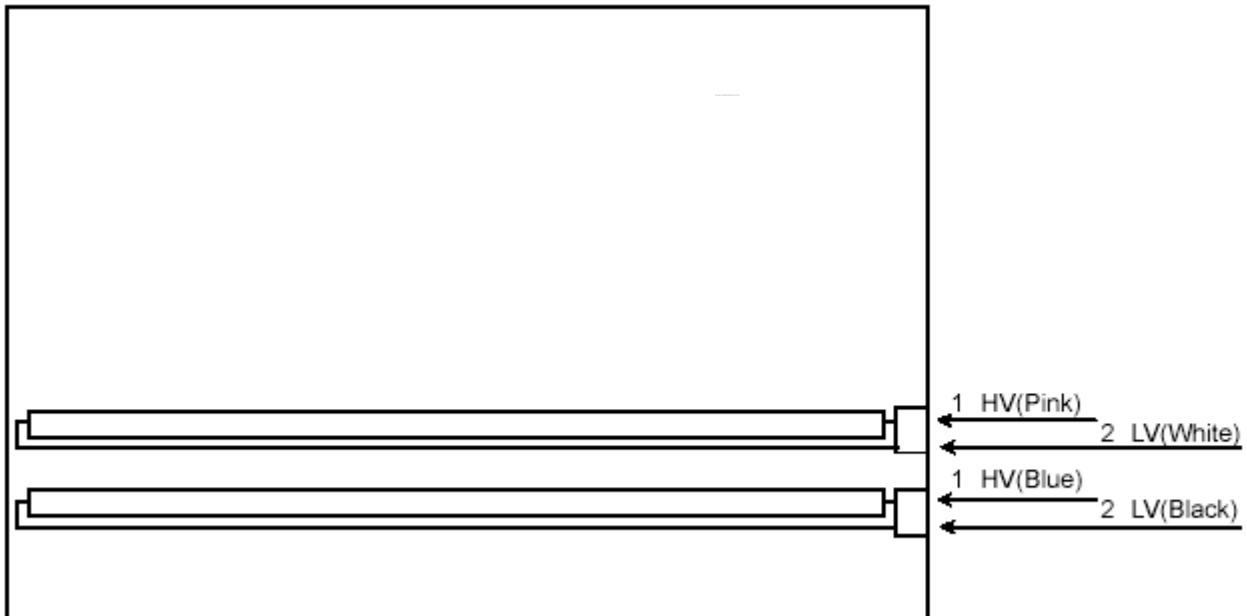

## 5. INPUT TERMINAL PIN ASSIGNMENT

### 5.1 TFT LCD MODULE

| Pin | Symbol               | Description                         | Polarity | Remark |
|-----|----------------------|-------------------------------------|----------|--------|
| 1   | Vss                  | Ground                              |          |        |
| 2   | Vcc                  | Power Supply +3.3 V (typical)       |          |        |
| 3   | Vcc                  | Power Supply +3.3 V (typical)       |          |        |
| 4   | V <sub>EDID</sub>    | DDC 3.3V Power                      |          |        |
| 5   | NC                   | Non-Connection                      |          |        |
| 6   | CLK <sub>EDID</sub>  | DDC Clock                           |          |        |
| 7   | DATA <sub>EDID</sub> | DDC Data                            |          |        |
| 8   | RXO0-                | LVDS Differential Data Input (Odd)  | Negative |        |
| 9   | RXO0+                | LVDS Differential Data Input (Odd)  | Positive |        |
| 10  | Vss                  | Ground                              |          |        |
| 11  | RXO1-                | LVDS Differential Data Input (Odd)  | Negative |        |
| 12  | RXO1+                | LVDS Differential Data Input (Odd)  | Positive |        |
| 13  | Vss                  | Ground                              |          |        |
| 14  | RXO2-                | LVDS Differential Data Input (Odd)  | Negative |        |
| 15  | RXO2+                | LVDS Differential Data Input (Odd)  | Positive |        |
| 16  | Vss                  | Ground                              |          |        |
| 17  | RXOC-                | LVDS Clock Data Input (Odd)         | Negative |        |
| 18  | RXOC+                | LVDS Clock Data Input (Odd)         | Positive |        |
| 19  | Vss                  | Ground                              |          |        |
| 20  | RxE0-                | LVDS Differential Data Input (Even) | Negative |        |
| 21  | RxE0+                | LVDS Differential Data Input (Even) | Positive |        |
| 22  | Vss                  | Ground                              |          |        |
| 23  | RxE1-                | LVDS Differential Data Input (Even) | Negative |        |
| 24  | RxE1+                | LVDS Differential Data Input (Even) | Positive |        |
| 25  | Vss                  | Ground                              |          |        |
| 26  | RxE2-                | LVDS Differential Data Input (Even) | Negative |        |
| 27  | RxE2+                | LVDS Differential Data Input (Even) | Positive |        |
| 28  | Vss                  | Ground                              |          |        |
| 29  | RXEC-                | LVDS Clock Data Input (Even)        | Negative |        |
| 30  | RXEC+                | LVDS Clock Data Input (Even)        | Positive |        |

Note (1) Connector Part No.: JAE-FI-XB30SL-HF10 or equivalent

Note (2) User's connector Part No: JAE-FI-X30C2L or equivalent

Note (3) The first pixel is odd as shown in the following figure.

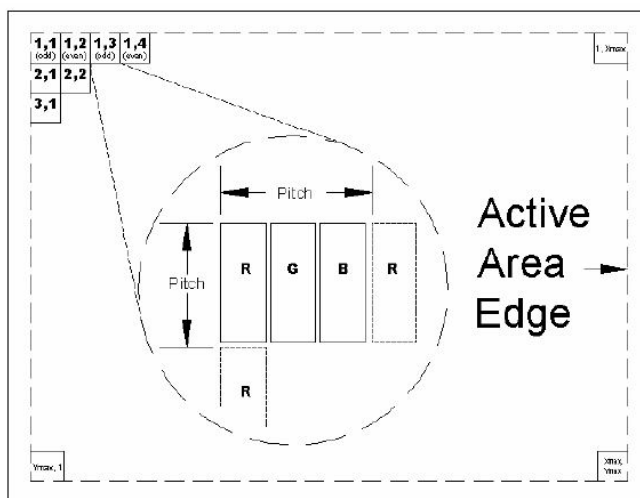

### 5.2 BACKLIGHT UNIT

| Pin | Symbol | Description  | Color |
|-----|--------|--------------|-------|
| 1   | HV     | High Voltage | Pink  |
| 2   | LV     | Ground       | White |
| 1   | HV     | High Voltage | Blue  |
| 2   | LV     | Ground       | Black |

Note (1) Connector Part No.: JST-BHSR-02VS-1 or equivalent

Note (2) User's connector Part No.: JST-SM02B-BHSS-1-TB or equivalent

### 5.3 TIMING DIAGRAM OF LVDS INPUT SIGNAL

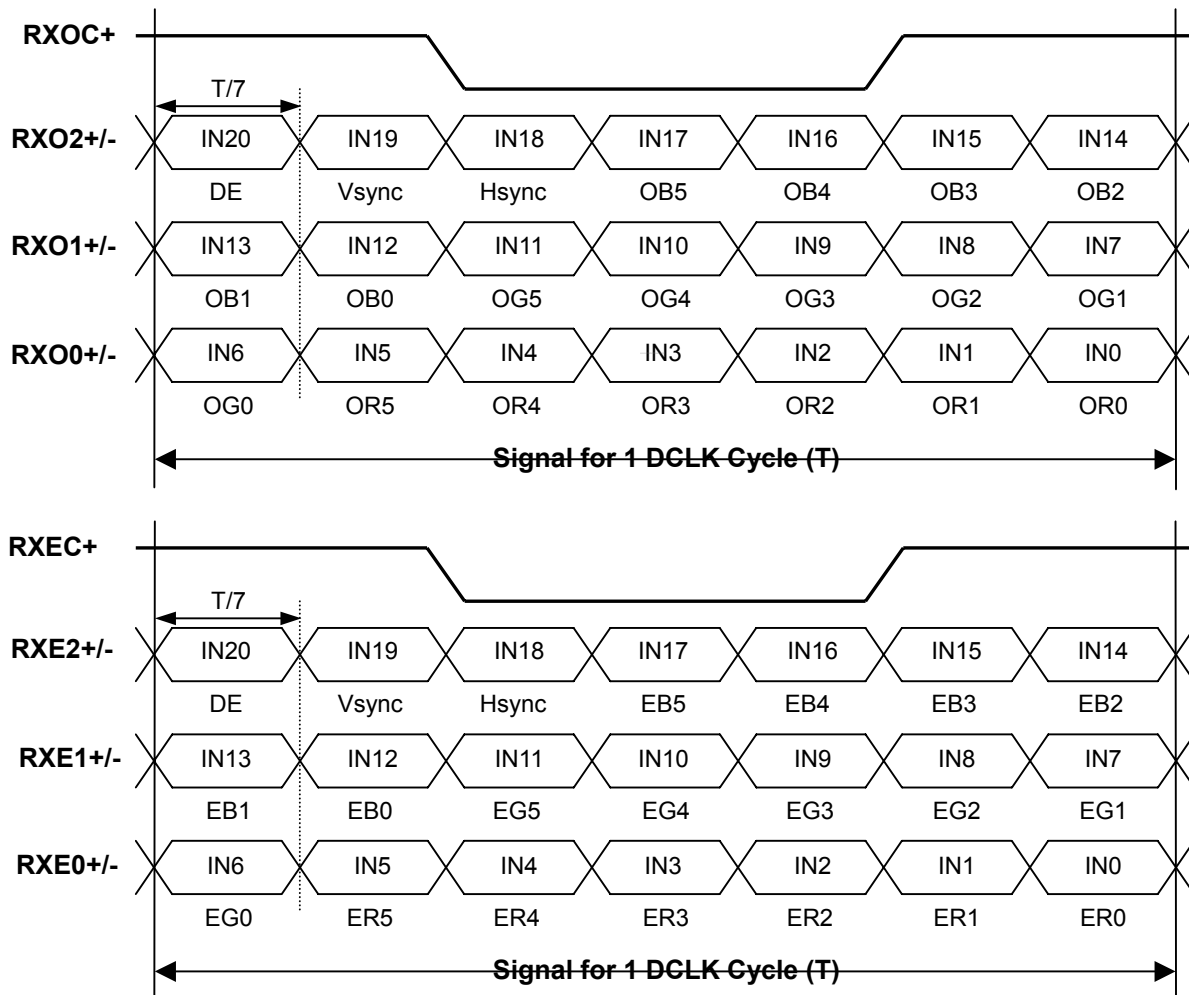

### 5.4 COLOR DATA INPUT ASSIGNMENT

The brightness of each primary color (red, green and blue) is based on the 6-bit gray scale data input for the color. The higher the binary input, the brighter the color. The table below provides the assignment of color versus data input.

| Color               |               | Data Signal |    |    |    |    |    |       |    |    |    |    |    |      |    |    |    |    |    |
|---------------------|---------------|-------------|----|----|----|----|----|-------|----|----|----|----|----|------|----|----|----|----|----|
|                     |               | Red         |    |    |    |    |    | Green |    |    |    |    |    | Blue |    |    |    |    |    |
|                     |               | R5          | R4 | R3 | R2 | R1 | R0 | G5    | G4 | G3 | G2 | G1 | G0 | B5   | B4 | B3 | B2 | B1 | B0 |
| Basic Colors        | Black         | 0           | 0  | 0  | 0  | 0  | 0  | 0     | 0  | 0  | 0  | 0  | 0  | 0    | 0  | 0  | 0  | 0  | 0  |
|                     | Red           | 1           | 1  | 1  | 1  | 1  | 1  | 0     | 0  | 0  | 0  | 0  | 0  | 0    | 0  | 0  | 0  | 0  | 0  |
|                     | Green         | 0           | 0  | 0  | 0  | 0  | 0  | 1     | 1  | 1  | 1  | 1  | 1  | 0    | 0  | 0  | 0  | 0  | 0  |
|                     | Blue          | 0           | 0  | 0  | 0  | 0  | 0  | 0     | 0  | 0  | 0  | 0  | 0  | 1    | 1  | 1  | 1  | 1  | 1  |
|                     | Cyan          | 0           | 0  | 0  | 0  | 0  | 0  | 1     | 1  | 1  | 1  | 1  | 1  | 1    | 1  | 1  | 1  | 1  | 1  |
|                     | Magenta       | 1           | 1  | 1  | 1  | 1  | 1  | 0     | 0  | 0  | 0  | 0  | 0  | 0    | 1  | 1  | 1  | 1  | 1  |
|                     | Yellow        | 1           | 1  | 1  | 1  | 1  | 1  | 1     | 1  | 1  | 1  | 1  | 1  | 0    | 0  | 0  | 0  | 0  | 0  |
|                     | White         | 1           | 1  | 1  | 1  | 1  | 1  | 1     | 1  | 1  | 1  | 1  | 1  | 1    | 1  | 1  | 1  | 1  | 1  |
| Gray Scale Of Red   | Red(0)/Dark   | 0           | 0  | 0  | 0  | 0  | 0  | 0     | 0  | 0  | 0  | 0  | 0  | 0    | 0  | 0  | 0  | 0  | 0  |
|                     | Red(1)        | 0           | 0  | 0  | 0  | 0  | 1  | 0     | 0  | 0  | 0  | 0  | 0  | 0    | 0  | 0  | 0  | 0  | 0  |
|                     | Red(2)        | 0           | 0  | 0  | 0  | 1  | 0  | 0     | 0  | 0  | 0  | 0  | 0  | 0    | 0  | 0  | 0  | 0  | 0  |
|                     | :             | :           | :  | :  | :  | :  | :  | :     | :  | :  | :  | :  | :  | :    | :  | :  | :  | :  | :  |
|                     | :             | :           | :  | :  | :  | :  | :  | :     | :  | :  | :  | :  | :  | :    | :  | :  | :  | :  | :  |
|                     | :             | :           | :  | :  | :  | :  | :  | :     | :  | :  | :  | :  | :  | :    | :  | :  | :  | :  | :  |
|                     | Red(61)       | 1           | 1  | 1  | 1  | 0  | 1  | 0     | 0  | 0  | 0  | 0  | 0  | 0    | 0  | 0  | 0  | 0  | 0  |
|                     | Red(62)       | 1           | 1  | 1  | 1  | 1  | 0  | 0     | 0  | 0  | 0  | 0  | 0  | 0    | 0  | 0  | 0  | 0  | 0  |
| Red(63)             | 1             | 1           | 1  | 1  | 1  | 1  | 0  | 0     | 0  | 0  | 0  | 0  | 0  | 0    | 0  | 0  | 0  | 0  |    |
| Gray Scale Of Green | Green(0)/Dark | 0           | 0  | 0  | 0  | 0  | 0  | 0     | 0  | 0  | 0  | 0  | 0  | 0    | 0  | 0  | 0  | 0  | 0  |
|                     | Green(1)      | 0           | 0  | 0  | 0  | 0  | 0  | 0     | 0  | 0  | 0  | 0  | 1  | 0    | 0  | 0  | 0  | 0  | 0  |
|                     | Green(2)      | 0           | 0  | 0  | 0  | 0  | 0  | 0     | 0  | 0  | 0  | 1  | 0  | 0    | 0  | 0  | 0  | 0  | 0  |
|                     | :             | :           | :  | :  | :  | :  | :  | :     | :  | :  | :  | :  | :  | :    | :  | :  | :  | :  | :  |
|                     | :             | :           | :  | :  | :  | :  | :  | :     | :  | :  | :  | :  | :  | :    | :  | :  | :  | :  | :  |
|                     | :             | :           | :  | :  | :  | :  | :  | :     | :  | :  | :  | :  | :  | :    | :  | :  | :  | :  | :  |
|                     | Green(61)     | 0           | 0  | 0  | 0  | 0  | 0  | 1     | 1  | 1  | 1  | 0  | 1  | 0    | 0  | 0  | 0  | 0  | 0  |
|                     | Green(62)     | 0           | 0  | 0  | 0  | 0  | 0  | 1     | 1  | 1  | 1  | 1  | 0  | 0    | 0  | 0  | 0  | 0  | 0  |
| Green(63)           | 0             | 0           | 0  | 0  | 0  | 0  | 1  | 1     | 1  | 1  | 1  | 1  | 0  | 0    | 0  | 0  | 0  | 0  |    |
| Gray Scale Of Blue  | Blue(0)/Dark  | 0           | 0  | 0  | 0  | 0  | 0  | 0     | 0  | 0  | 0  | 0  | 0  | 0    | 0  | 0  | 0  | 0  | 0  |
|                     | Blue(1)       | 0           | 0  | 0  | 0  | 0  | 0  | 0     | 0  | 0  | 0  | 0  | 0  | 0    | 0  | 0  | 0  | 0  | 1  |
|                     | Blue(2)       | 0           | 0  | 0  | 0  | 0  | 0  | 0     | 0  | 0  | 0  | 0  | 0  | 0    | 0  | 0  | 0  | 1  | 0  |
|                     | :             | :           | :  | :  | :  | :  | :  | :     | :  | :  | :  | :  | :  | :    | :  | :  | :  | :  | :  |
|                     | :             | :           | :  | :  | :  | :  | :  | :     | :  | :  | :  | :  | :  | :    | :  | :  | :  | :  | :  |
|                     | :             | :           | :  | :  | :  | :  | :  | :     | :  | :  | :  | :  | :  | :    | :  | :  | :  | :  | :  |
|                     | Blue(61)      | 0           | 0  | 0  | 0  | 0  | 0  | 0     | 0  | 0  | 0  | 0  | 0  | 1    | 1  | 1  | 1  | 0  | 1  |
|                     | Blue(62)      | 0           | 0  | 0  | 0  | 0  | 0  | 0     | 0  | 0  | 0  | 0  | 0  | 1    | 1  | 1  | 1  | 1  | 0  |
| Blue(63)            | 0             | 0           | 0  | 0  | 0  | 0  | 0  | 0     | 0  | 0  | 0  | 0  | 1  | 1    | 1  | 1  | 1  | 1  |    |

Note (1) 0: Low Level Voltage, 1: High Level Voltage

## 5.5 EDID DATA STRUCTURE

The EDID (Extended Display Identification Data) data formats are to support displays as defined in the VESA Plug & Display and FPD1 standards.

| Byte #<br>(decimal) | Byte #<br>(hex) | Field Name and Comments                             | Value<br>(hex) | Value<br>(binary) |
|---------------------|-----------------|---|----------------|-------------------|
| 0                   | 0               | Header  | 00             | 00000000          |
| 1                   | 1               | Header  | FF             | 11111111          |
| 2                   | 2               | Header  | FF             | 11111111          |
| 3                   | 3               | Header  | FF             | 11111111          |
| 4                   | 4               | Header  | FF             | 11111111          |
| 5                   | 5               | Header  | FF             | 11111111          |
| 6                   | 6               | Header  | FF             | 11111111          |
| 7                   | 7               | Header  | 00             | 00000000          |
| 8                   | 8               | EISA ID manufacturer name ("CMO")                   | 0D             | 00001101          |
| 9                   | 9               | EISA ID manufacturer name (Compressed ASCII)        | AF             | 10101111          |
| 10                  | 0A              | ID product code (N170C1-L02)                        | 01             | 00000001          |
| 11                  | 0B              | ID product code (hex LSB first; N170C1-L02)         | 17             | 00010111          |
| 12                  | 0C              | ID S/N (fixed "0")                                  | 00             | 00000000          |
| 13                  | 0D              | ID S/N (fixed "0")                                  | 00             | 00000000          |
| 14                  | 0E              | ID S/N (fixed "0")                                  | 00             | 00000000          |
| 15                  | 0F              | ID S/N (fixed "0")                                  | 00             | 00000000          |
| 16                  | 10              | Week of manufacture (fixed "00H")                   | 00             | 00000000          |
| 17                  | 11              | Year of manufacture (fixed "00H")                   | 00             | 00000000          |
| 18                  | 12              | EDID structure version # ("1")                      | 01             | 00000001          |
| 19                  | 13              | EDID revision # ("3")                               | 03             | 00000011          |
| 20                  | 14              | Video I/P definition ("digital")                    | 80             | 10000000          |
| 21                  | 15              | Max H image size ("37cm")                           | 25             | 00100101          |
| 22                  | 16              | Max V image size ("23cm")                           | 17             | 00010111          |
| 23                  | 17              | Display Gamma (Gamma = "2.2")                       | 78             | 01111000          |
| 24                  | 18              | Feature support ("Active off, RGB Color")           | 0A             | 00001010          |
| 25                  | 19              | Red/Green (Rx1, Rx0, Ry1, Ry0, Gx1, Gx0, Gy1, Gy0)  | FA             | 11111010          |
| 26                  | 1A              | Blue/White (Bx1, Bx0, By1, By0, Wx1, Wx0, Wy1, Wy0) | 1D             | 00011101          |
| 27                  | 1B              | Red-x (Rx = "0.648")                                | A5             | 10100101          |
| 28                  | 1C              | Red-y (Ry = "0.347")                                | 58             | 01011000          |
| 29                  | 1D              | Green-x (Gx = "0.283")                              | 48             | 01001000          |
| 30                  | 1E              | Green-y (Gy = "0.611")                              | 9C             | 10011100          |
| 31                  | 1F              | Blue-x (Bx = "0.141")                               | 24             | 00100100          |
| 32                  | 20              | Blue-y (By = "0.071")                               | 12             | 00010010          |
| 33                  | 21              | White-x (Wx = "0.319")                              | 51             | 01010001          |
| 34                  | 22              | White-y (Wy = "0.333")                              | 55             | 01010101          |
| 35                  | 23              | Established timings 1                               | 00             | 00000000          |
| 36                  | 24              | Established timings 2                               | 00             | 00000000          |
| 37                  | 25              | Manufacturer's reserved timings                     | 00             | 00000000          |
| 38                  | 26              | Standard timing ID # 1                              | 01             | 00000001          |
| 39                  | 27              | Standard timing ID # 1                              | 01             | 00000001          |
| 40                  | 28              | Standard timing ID # 2                              | 01             | 00000001          |
| 41                  | 29              | Standard timing ID # 2                              | 01             | 00000001          |

| Byte #<br>(decimal) | Byte #<br>(hex) | Field Name and Comments  | Value<br>(hex) | Value<br>(binary) |
|---------------------|-----------------|--|----------------|-------------------|
| 42                  | 2A              | Standard timing ID # 3   | 01             | 00000001          |
| 43                  | 2B              | Standard timing ID # 3   | 01             | 00000001          |
| 44                  | 2C              | Standard timing ID # 4   | 01             | 00000001          |
| 45                  | 2D              | Standard timing ID # 4   | 01             | 00000001          |
| 46                  | 2E              | Standard timing ID # 5   | 01             | 00000001          |
| 47                  | 2F              | Standard timing ID # 5   | 01             | 00000001          |
| 48                  | 30              | Standard timing ID # 6   | 01             | 00000001          |
| 49                  | 31              | Standard timing ID # 6   | 01             | 00000001          |
| 50                  | 32              | Standard timing ID # 7   | 01             | 00000001          |
| 51                  | 33              | Standard timing ID # 7   | 01             | 00000001          |
| 52                  | 34              | Standard timing ID # 8   | 01             | 00000001          |
| 53                  | 35              | Standard timing ID # 8   | 01             | 00000001          |
| 54                  | 36              | Detailed timing description # 1 Pixel clock ("96.21MHz")                                 | 95             | 10010101          |
| 55                  | 37              | # 1 Pixel clock (hex LSB first)  | 25             | 00100101          |
| 56                  | 38              | # 1 H active ("1440")  | A0             | 10100000          |
| 57                  | 39              | # 1 H blank ("320")  | 40             | 01000000          |
| 58                  | 3A              | # 1 H active : H blank ("1440 : 320")  | 51             | 01010001          |
| 59                  | 3B              | # 1 V active ("900")   | 84             | 10000100          |
| 60                  | 3C              | # 1 V blank ("12")   | 0C             | 00001100          |
| 61                  | 3D              | # 1 V active : V blank ("900 :12")   | 30             | 00110000          |
| 62                  | 3E              | # 1 H sync offset ("64")   | 40             | 01000000          |
| 63                  | 3F              | # 1 H sync pulse width ("32")  | 20             | 00100000          |
| 64                  | 40              | # 1 V sync offset : V sync pulse width ("3 : 3")   | 33             | 00110011          |
| 65                  | 41              | # 1 H sync offset : H sync pulse width : V sync offset : V sync width ("64: 32 : 3 : 3") | 00             | 00000000          |
| 66                  | 42              | # 1 H image size ("367.2 mm")  | 6F             | 01101111          |
| 67                  | 43              | # 1 V image size ("229.5 mm")  | E6             | 11100110          |
| 68                  | 44              | # 1 H image size : V image size ("367.2 : 229.5")  | 10             | 00010000          |
| 69                  | 45              | # 1 H boarder ("0")  | 00             | 00000000          |
| 70                  | 46              | # 1 V boarder ("0")  | 00             | 00000000          |
| 71                  | 47              | # 1 Non-interlaced, Normal, no stereo, Separate sync, H/V pol<br>Negatives               | 18             | 00011000          |
| 72                  | 48              | Detailed timing description # 2  | 00             | 00000000          |
| 73                  | 49              | # 2 Flag   | 00             | 00000000          |
| 74                  | 4A              | # 2 Reserved   | 00             | 00000000          |
| 75                  | 4B              | # 2 FE (hex) defines ASCII string (Model Name "N170C1-L02",<br>ASCII)                    | FE             | 11111110          |
| 76                  | 4C              | # 2 Flag   | 00             | 00000000          |
| 77                  | 4D              | # 2 1st character of name ("N")  | 4E             | 01001110          |
| 78                  | 4E              | # 2 2nd character of name ("1")  | 31             | 00110001          |
| 79                  | 4F              | # 2 3rd character of name ("7")  | 37             | 00110111          |
| 80                  | 50              | # 2 4th character of name ("0")  | 30             | 00110000          |
| 81                  | 51              | # 2 5th character of name ("C")  | 43             | 01000011          |
| 82                  | 52              | # 2 6th character of name ("1")  | 31             | 00110001          |
| 83                  | 53              | # 2 7th character of name ("-")  | 2D             | 00101101          |
| 84                  | 54              | # 2 8th character of name ("L")  | 4C             | 01001100          |
| 85                  | 55              | # 2 9th character of name ("0")  | 30             | 00110000          |

| Byte #<br>(decimal) | Byte #<br>(hex) | Field Name and Comments  | Value<br>(hex) | Value<br>(binary) |
|---------------------|-----------------|--|----------------|-------------------|
| 86                  | 56              | # 2 9th character of name ("2")                                    | 32             | 00110010          |
| 87                  | 57              | # 2 New line character indicates end of ASCII string               | 0A             | 00001010          |
| 88                  | 58              | # 2 Padding with "Blank" character                                 | 20             | 00100000          |
| 89                  | 59              | # 2 Padding with "Blank" character                                 | 20             | 00100000          |
| 90                  | 5A              | Detailed timing description # 3                                    | 00             | 00000000          |
| 91                  | 5B              | # 3 Flag   | 00             | 00000000          |
| 92                  | 5C              | # 3 Reserved   | 00             | 00000000          |
| 93                  | 5D              | # 3 FE (hex) defines ASCII string (Vendor "CMO", ASCII)            | FE             | 11111110          |
| 94                  | 5E              | # 3 Flag   | 00             | 00000000          |
| 95                  | 5F              | # 3 1st character of string ("C")                                  | 43             | 01000011          |
| 96                  | 60              | # 3 2nd character of string ("M")                                  | 4D             | 01001101          |
| 97                  | 61              | # 3 3rd character of string ("O")                                  | 4F             | 01001111          |
| 98                  | 62              | # 3 New line character indicates end of ASCII string               | 0A             | 00001010          |
| 99                  | 63              | # 3 Padding with "Blank" character                                 | 20             | 00100000          |
| 100                 | 64              | # 3 Padding with "Blank" character                                 | 20             | 00100000          |
| 101                 | 65              | # 3 Padding with "Blank" character                                 | 20             | 00100000          |
| 102                 | 66              | # 3 Padding with "Blank" character                                 | 20             | 00100000          |
| 103                 | 67              | # 3 Padding with "Blank" character                                 | 20             | 00100000          |
| 104                 | 68              | # 3 Padding with "Blank" character                                 | 20             | 00100000          |
| 105                 | 69              | # 3 Padding with "Blank" character                                 | 20             | 00100000          |
| 106                 | 6A              | # 3 Padding with "Blank" character                                 | 20             | 00100000          |
| 107                 | 6B              | # 3 Padding with "Blank" character                                 | 20             | 00100000          |
| 108                 | 6C              | Detailed timing description # 4                                    | 00             | 00000000          |
| 109                 | 6D              | # 4 Flag   | 00             | 00000000          |
| 110                 | 6E              | # 4 Reserved   | 00             | 00000000          |
| 111                 | 6F              | # 4 FE (hex) defines ASCII string (Model Name "N170C1-L02", ASCII) | FE             | 11111110          |
| 112                 | 70              | # 4 Flag   | 00             | 00000000          |
| 113                 | 71              | # 4 1st character of name ("N")                                    | 4E             | 01001110          |
| 114                 | 72              | # 4 2nd character of name ("1")                                    | 31             | 00110001          |
| 115                 | 73              | # 4 3rd character of name ("7")                                    | 37             | 00110111          |
| 116                 | 74              | # 4 4th character of name ("0")                                    | 30             | 00110000          |
| 117                 | 75              | # 4 5th character of name ("C")                                    | 43             | 01000011          |
| 118                 | 76              | # 4 6th character of name ("1")                                    | 31             | 00110001          |
| 119                 | 77              | # 4 7th character of name ("-")                                    | 2D             | 00101101          |
| 120                 | 78              | # 4 8th character of name ("L")                                    | 4C             | 01001100          |
| 121                 | 79              | # 4 9th character of name ("0")                                    | 30             | 00110000          |
| 122                 | 7A              | # 4 9th character of name ("2")                                    | 32             | 00110010          |
| 123                 | 7B              | # 4 New line character indicates end of ASCII string               | 0A             | 00001010          |
| 124                 | 7C              | # 4 Padding with "Blank" character                                 | 20             | 00100000          |
| 125                 | 7D              | # 4 Padding with "Blank" character                                 | 20             | 00100000          |
| 126                 | 7E              | Extension flag   | 00             | 00000000          |
| 127                 | 7F              | Checksum   | 50             | 01010000          |



## 5.6 EDID SIGNAL SPECIFICATION

### (1) EDID Power

| Parameter                        | Symbol | Conditions     | Min. | Typ. | Max. | Unit |
|----------------------------------|--------|----------------|------|------|------|------|
| Absolute Maximum Ratings         | Vcc    |                | 0    | —    | 7.0  | V    |
| Recommended Operating Conditions | Vcc    | Read Operation | 2.7  | —    | 5.5  | V    |

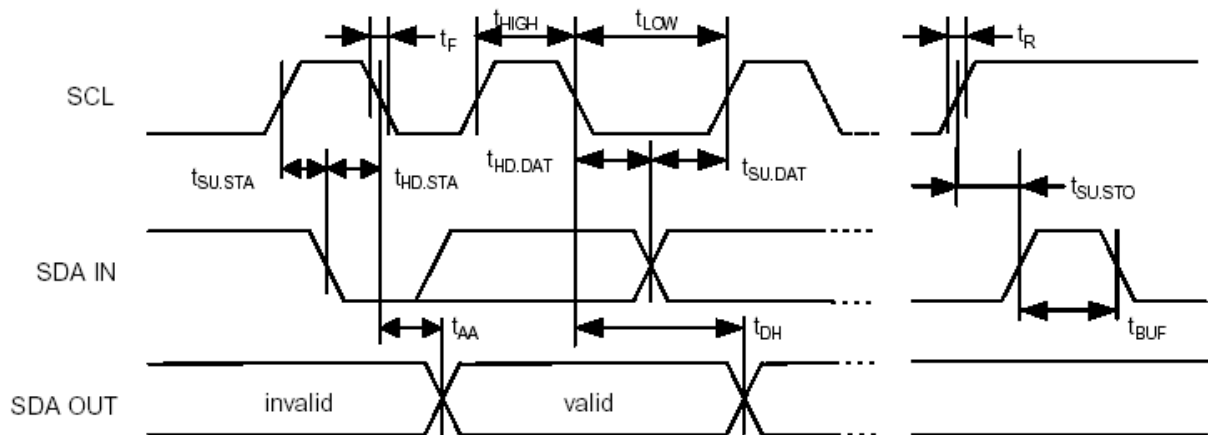

### (2) DC characteristics

|  |              | Symbol  | Min.                 | Max.                | Unit | Index  |
|--|--------------|---|----------------------|---------------------|------|--|
| SCL, SDA terminal input voltage  | High Voltage | V <sub>IH</sub>                               | 0.7×V <sub>CC</sub>  | —                   | V    |  |
|  | Low Voltage  | V <sub>IL</sub>                               | —                    | 0.3×V <sub>CC</sub> | V    |  |
| Hysteresis Voltage   |              | V <sub>HYS</sub>                              | 0.05 V <sub>CC</sub> | —                   | V    |  |
| Output Voltage   |              | V <sub>OL1</sub><br>V <sub>OL2</sub>          | —                    | 0.4<br>0.6          | V    | I <sub>OL</sub> =3mA, C <sub>C</sub> =2.5V<br>I <sub>OL</sub> =6mA, C <sub>C</sub> =2.5V |
| Input Leak current<br>(V <sub>in</sub> =0.1V~V <sub>CC</sub> )   |              | I <sub>LI</sub>                               | -10<br>-10           | 10<br>50            | uA   | W <sub>P</sub> =V <sub>SS</sub><br>W <sub>P</sub> =V <sub>CC</sub>                       |
| Output Leak current  |              | I <sub>LO</sub>                               | -10                  | 10                  | uA   | V <sub>out</sub> =0.1V~V <sub>CC</sub> ,<br>W <sub>P</sub> =V <sub>SS</sub>              |
| Terminal capacity(Input, Output)   |              | C <sub>in</sub> , C <sub>out</sub>            | —                    | 10                  | pF   | V <sub>CC</sub> =5.0V<br>T <sub>a</sub> =25°C,<br>F <sub>clk</sub> =1.0MHz               |
| Operating current  |              | I <sub>CC</sub> Write<br>I <sub>CC</sub> Read | —                    | 3<br>1              | mA   | V <sub>CC</sub> =5.5V,<br>SCL=400KHz   |
| Stillness current<br>(S <sub>DA</sub> =S <sub>CL</sub> =V <sub>CC</sub> )<br>(W <sub>P</sub> =V <sub>SS</sub> ,A <sub>0</sub> ,A <sub>1</sub> ,A <sub>2</sub> =V <sub>SS</sub> ) |              | I <sub>CCS</sub>                              | —                    | 30<br>100           | uA   | V <sub>CC</sub> =3.0V<br>V <sub>CC</sub> =5.5V   |

## (3) AC characteristics (VCC=2.5~5.5V standard operation mode)

| Item                                  | Symbol    | VCC=2.5V-5.5V<br>(Standard operation mode) |      | VCC=4.5V-5.5V<br>(High-speed operation mode) |      | Unit   | Index                |
|---------------------------------------|-----------|--|------|--|------|--------|----------------------|
|                                       |           | Min.                                       | Max. | Min.   | Max. |        |                      |
| Clock frequency                       | Fclk      | —  | 100  | —  | 400  | KHz    |                      |
| Clock High Time                       | THIGH     | 4000                                       | —    | 900  | —    | ns     |                      |
| Clock Low Time                        | TLOW      | 4700                                       | —    | 1300   | —    | ns     |                      |
| SDA, SCL falling time                 | TR        | —  | 1000 | —  | 300  | ns     |                      |
| SDA, SCL rising time                  | TF        | —  | 300  | —  | 300  | ns     |                      |
| START hold time                       | THD: STA  | 4000                                       | —    | 600  | —    | ns     |                      |
| START setup time                      | TSU: STA  | 4700                                       | —    | 600  | —    | ns     |                      |
| Data input hold time                  | THD: Data | 0  | —    | 0  | —    | ns     |                      |
| Data input setup time                 | TSU: Data | 250  | —    | 100  | —    | ns     |                      |
| STOP setup time                       | TSU: STO  | 4700                                       | —    | 600  | —    | ns     |                      |
| Output decision time from a clock     | TAA       | —  | 3500 | 100  | 900  | ns     |                      |
| Bus free time                         | TBUF      | 4700                                       | —    | 1300   | —    | ns     |                      |
| Rising time of Min VIH, VIL           | TOF       | —  | 250  | 20   | 250  | ns     | CB ≤ 100pF           |
| Spike oppression                      | TSP       | —  | 50   | —  | 50   | ns     |                      |
| A write-in cycle time                 | TWR       | —  | 10   | —  | 10   | ms     | Byte and page mode   |
| The number of times of data rewriting | —         | 1M   | —    | 1M   | —    | cycles | VCC=5.0V<br>Ta=25°C, |

## (4) Device Addressing

| Device Code |   |   |   | Slave Address |    |    | R/W |
|-------------|---|---|---|---------------|----|----|-----|
|             |   |   |   | A2            | A1 | A0 |     |
| 1           | 0 | 1 | 0 | 0             | 0  | 0  | R/W |

## 6. INTERFACE TIMING

### 6.1 INPUT SIGNAL TIMING SPECIFICATIONS

The input signal timing specifications are shown as the following table and timing diagram.

| Signal | Item                              | Symbol | Min.   | Typ. | Max.   | Unit | Note |
|--------|-----------------------------------|--------|--------|------|--------|------|------|
| DCLK   | Frequency                         | 1/Tc   | 40.1   | 48.1 | 49.7   | MHz  | (2)  |
| DE     | Vertical Total Time               | TV     | 905    | 912  | 950    | TH   | -    |
|        | Vertical Active Display Period    | TVD    | 900    | 900  | 900    | TH   | -    |
|        | Vertical Active Blanking Period   | TVB    | TV-TVD | 12   | TV-TVD | TH   |      |
|        | Horizontal Total Time             | TH     | 832    | 880  | 1000   | Tc   | (2)  |
|        | Horizontal Active Display Period  | THD    | 720    | 720  | 720    | Tc   | (2)  |
|        | Horizontal Active Blanking Period | THB    | TH-THD | 160  | TH-THD | Tc   | (2)  |

Note (1) Because this module is operated by DE only mode, Hsync and Vsync are ignored.

(2) 2 channels LVDS input.

### INPUT SIGNAL TIMING DIAGRAM

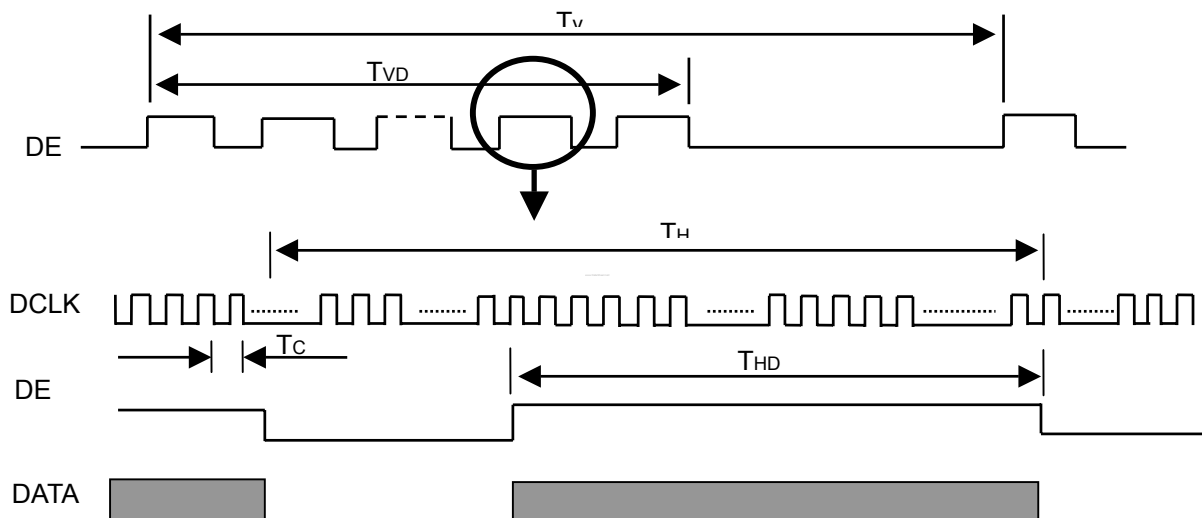

### 6.2 POWER ON/OFF SEQUENCE

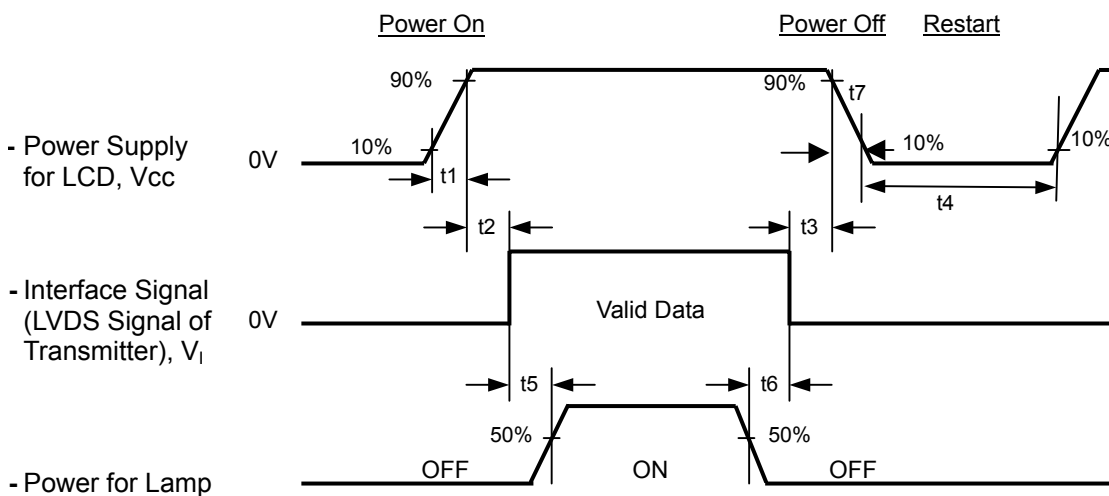

Timing Specifications:

$$0.5 \leq t1 \leq 10 \text{ ms}$$

$$0 \leq t2 \leq 50 \text{ ms}$$

$$0 \leq t3 \leq 50 \text{ ms}$$

$$t4 \geq 500 \text{ ms}$$

$$t5 \geq 200 \text{ ms}$$

$$t6 \geq 200 \text{ ms}$$

Note (1) Please avoid floating state of interface signal at invalid period.

Note (2) When the interface signal is invalid, be sure to pull down the power supply of LCD Vcc to 0 V.

Note (3) The Backlight inverter power must be turned on after the power supply for the logic and the interface signal is valid. The Backlight inverter power must be turned off before the power supply for the logic and the interface signal is invalid.

Note (4) Sometimes some slight noise shows when LCD is turned off (even backlight is already off). To avoid this phenomenon, we suggest that the Vcc falling time is better to follow  $t7 \geq 5 \text{ msec}$

## 7. OPTICAL CHARACTERISTICS

### 7.1 TEST CONDITIONS

| Item                       | Symbol  | Value | Unit |
|----------------------------|---|-------|------|
| Ambient Temperature        | Ta  | 25±2  | °C   |
| Ambient Humidity           | Ha  | 50±10 | %RH  |
| Supply Voltage             | V <sub>CC</sub>   | 3.3   | V    |
| Input Signal               | According to typical value in "3. ELECTRICAL CHARACTERISTICS" |       |      |
| Inverter Current           | I <sub>L</sub>  | 6.0   | mA   |
| Inverter Driving Frequency | F <sub>L</sub>  | (61)  | KHz  |
| Inverter                   | (Sumida-H05-4915)   |       |      |

The relative measurement methods of optical characteristics are shown in 7.2. The following items should be measured under the test conditions described in 7.1 and stable environment shown in Note (6).

### 7.2 OPTICAL SPECIFICATIONS

| Item                      |            | Symbol           | Condition  | Min.          | Typ.    | Max.          | Unit              | Note     |
|---------------------------|------------|------------------|--|---------------|---------|---------------|-------------------|----------|
| Color Chromaticity        | Red        | Rx               | $\theta_x=0^\circ, \theta_y=0^\circ$<br>Viewing Normal Angle | Typ -<br>0.03 | (0.643) | Typ +<br>0.03 | —                 | (1), (6) |
|                           |            | Ry               |  |               | (0.349) |               |                   |          |
|                           | Green      | Gx               |  |               | (0.283) |               |                   |          |
|                           |            | Gy               |  |               | (0.600) |               |                   |          |
|                           | Blue       | Bx               |  |               | (0.142) |               |                   |          |
|                           |            | By               |  |               | (0.074) |               |                   |          |
|                           | White      | Wx               |  |               | 0.313   |               |                   |          |
|                           |            | Wy               |  |               | 0.329   |               |                   |          |
| Center Luminance of White |            | L <sub>CEN</sub> |  | (340)         | (400)   | —             | cd/m <sup>2</sup> | (4), (6) |
| Contrast Ratio            |            | CR               |  | (400)         | (550)   | —             | —                 | (2), (6) |
| Response Time             |            | T <sub>R</sub>   |  | —             | 5       | 10            | ms                | (3)      |
|                           |            | T <sub>F</sub>   |  | —             | 11      | 16            | ms                |          |
| White Variation           |            | δW               |  | —             | (1.25)  | (1.40)        | —                 | (5)      |
| Viewing Angle             | Horizontal | θ <sub>x+</sub>  | CR ≥ 10  | (60)          | (70)    | —             | Deg.              | (1)      |
|                           |            | θ <sub>x-</sub>  |  | (60)          | (70)    | —             |                   |          |
|                           | Vertical   | θ <sub>y+</sub>  |  | (50)          | (60)    | —             |                   |          |
|                           |            | θ <sub>y-</sub>  |  | (50)          | (60)    | —             |                   |          |

Note (1) Definition of Viewing Angle ( $\theta_x$ ,  $\theta_y$ ):

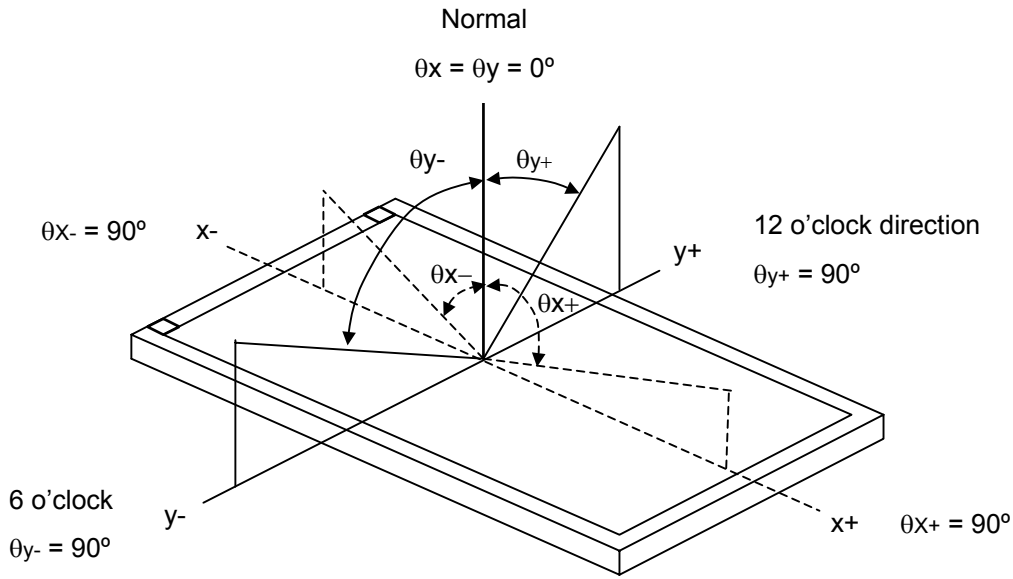

Note (2) Definition of Contrast Ratio (CR):

The contrast ratio can be calculated by the following expression.

$$\text{Contrast Ratio (CR)} = L_{63} / L_0$$

L63: Luminance of gray level 63

L 0: Luminance of gray level 0

$$CR = CR (5)$$

CR (X) is corresponding to the Contrast Ratio of the point X at Figure in Note (5).

Note (3) Definition of Response Time ( $T_R$ ,  $T_F$ ) and measurement method:

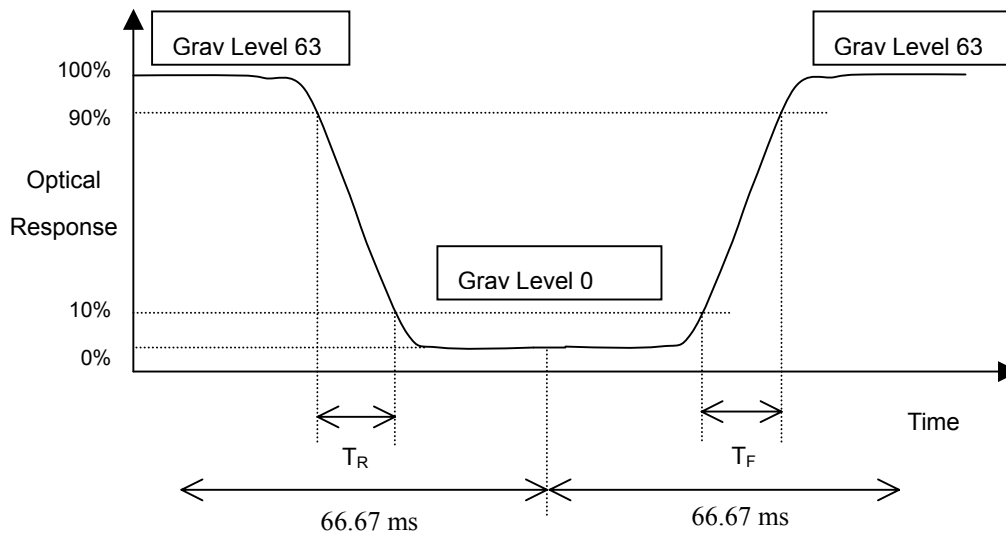

Note (4) Definition of Center Luminance of White ( $L_{CEN}$ ):

Measure the luminance of gray level 63 at center points

$$L_{CEN} = L(5)$$

$L(x)$  is corresponding to the luminance of the point X at Figure in Note (5)

Note (5) Definition of White Variation ( $\delta W$ ):

Measure the luminance of gray level 63 at 5 points

$$\delta W = \text{Maximum} [L(1), L(2), L(3), L(4), L(5)] / \text{Minimum} [L(1), L(2), L(3), L(4), L(5)]$$

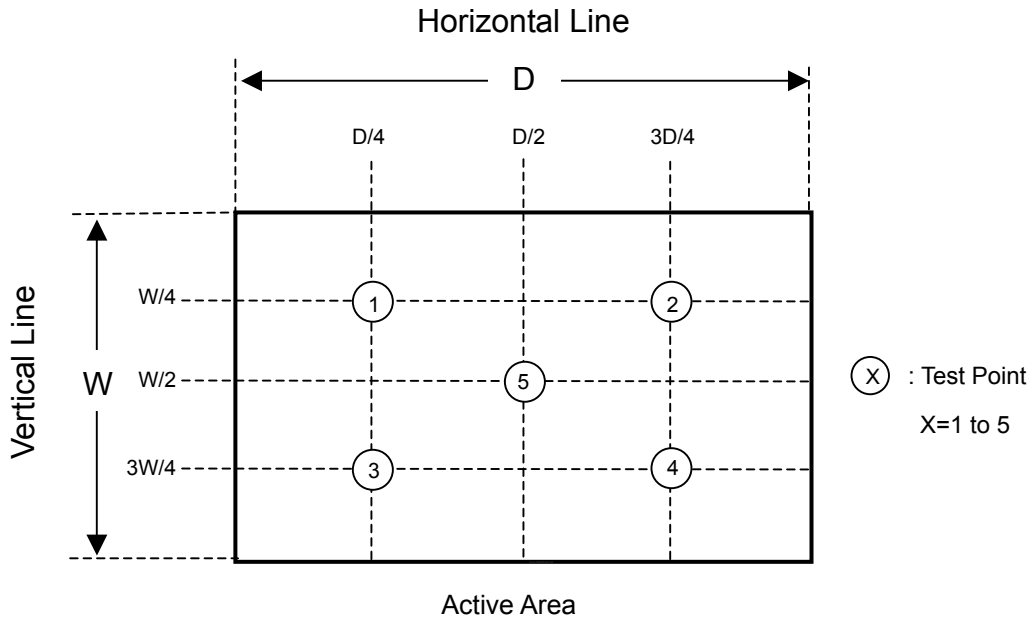

Note (6) Measurement Setup:

The LCD module should be stabilized at given temperature for 20 minutes to avoid abrupt temperature change during measuring. In order to stabilize the luminance, the measurement should be executed after lighting Backlight for 20 minutes in a windless room.

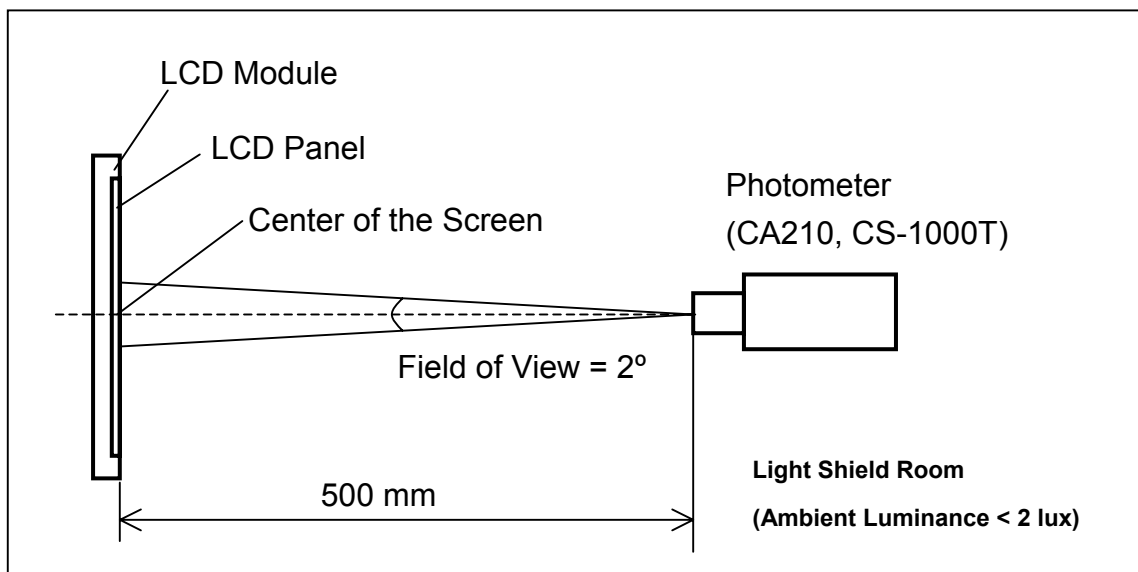

## 8. PRECAUTIONS

### 8.1 ASSEMBLY AND HANDLING PRECAUTIONS

- (1) Do not apply rough force such as bending or twisting to the module during assembly.
- (2) To assemble or install module into user's system can be only in clean working areas. The dust and oil may cause electrical short or worsen the polarizer.
- (3) It's not permitted to have pressure or impulse on the module because the LCD panel and Backlight will be damaged.
- (4) Always follow the correct power sequence when LCD module is connecting and operating. This can prevent damage to the CMOS LSI chips during latch-up.
- (5) Do not pull the I/F connector in or out while the module is operating.
- (6) Do not disassemble the module.
- (7) Use a soft dry cloth without chemicals for cleaning, because the surface of polarizer is very soft and easily scratched.
- (8) It is dangerous that moisture come into or contacted the LCD module, because moisture may damage LCD module when it is operating.
- (9) High temperature or humidity may reduce the performance of module. Please store LCD module within the specified storage conditions.
- (10) When ambient temperature is lower than 10°C may reduce the display quality. For example, the response time will become slowly, and the starting voltage of CCFL will be higher than room temperature.

### 8.2 SAFETY PRECAUTIONS

- (1) The startup voltage of Backlight is approximately 1000 Volts. It may cause electrical shock while assembling with inverter. Do not disassemble the module or insert anything into the Backlight unit.
- (2) If the liquid crystal material leaks from the panel, it should be kept away from the eyes or mouth. In case of contact with hands, skin or clothes, it has to be washed away thoroughly with soap.
- (3) After the module's end of life, it is not harmful in case of normal operation and storage.



9. PACKING

9.1 CARTON

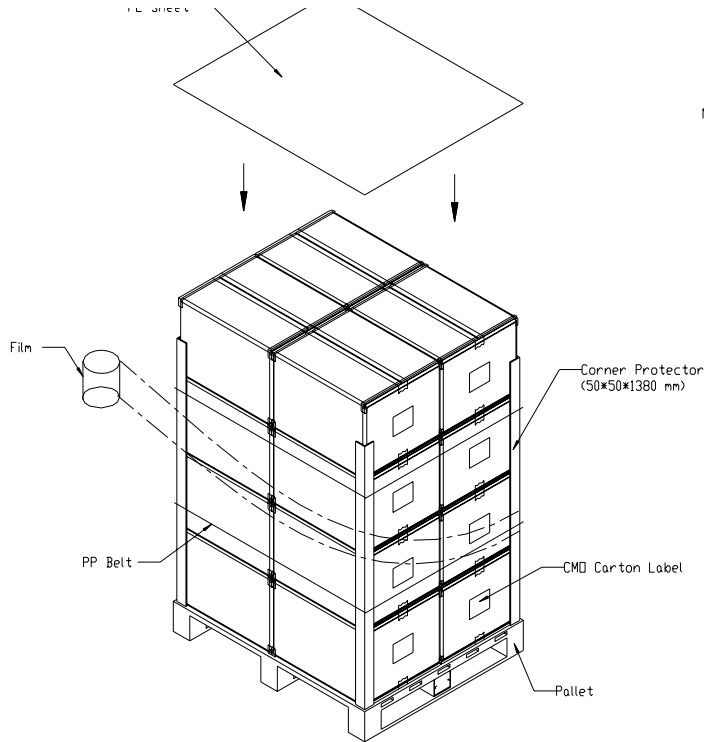

NOTES:  
Corner Protector:L1380mm\*50mm\*50mm  
Pallet:L1050\*W870\*H135mm  
Pallet Stock Dim:L1050\*W870\*H1585mm  
Weight:Approx.285kg

9.2 PALLET

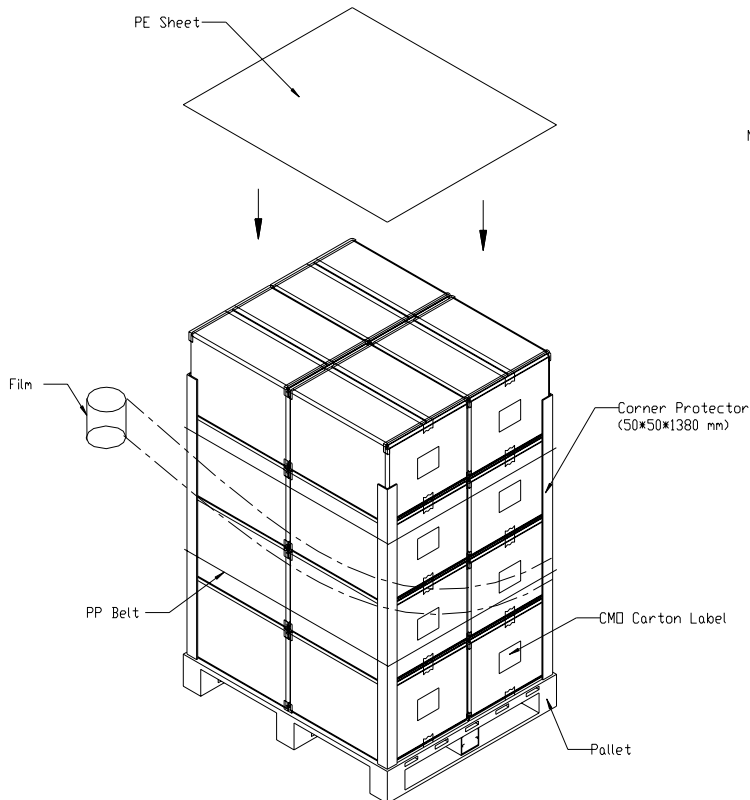

NOTES:  
Corner Protector:L1380mm\*50mm\*50mm  
Pallet:L1050\*W870\*H135mm  
Pallet Stock Dim:L1050\*W870\*H1585mm  
Weight:Approx.285kg

## 10. DEFINITION OF LABELS

### 10.1 CMO MODULE LABEL

The barcode nameplate is pasted on each module as illustration, and its definitions are as following explanation.

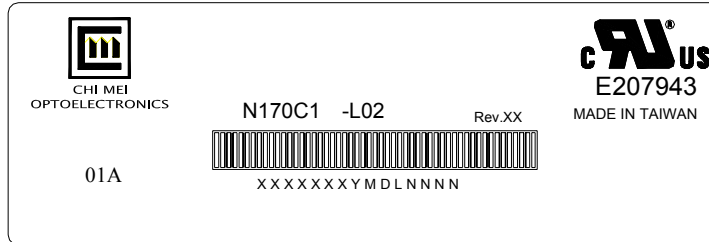

- (a) Model Name: N170C1 - L02
- (b) Revision: Rev. XX, for example: A1, ..., C1, C2 ...etc.
- (c) Serial ID: XXXXXXXYMDXNNNN

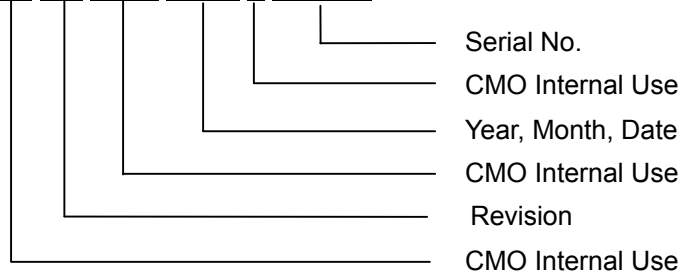

- (d) Customer Internal Product Code : CPxxxxxx-xx
- (e) Customer Internal Revision : XXX, for example: 01A, 02A ...etc

Serial ID includes the information as below:

- (a) Manufactured Date: Year: 1~9, for 2001~2009  
 Month: 1~9, A~C, for Jan. ~ Dec.  
 Day: 1~9, A~Y, for 1<sup>st</sup> to 31<sup>st</sup>, exclude I, O and U
- (b) Revision Code: cover all the change
- (c) Serial No.: Manufacturing sequence of product

### 10.2 CARTON LABEL

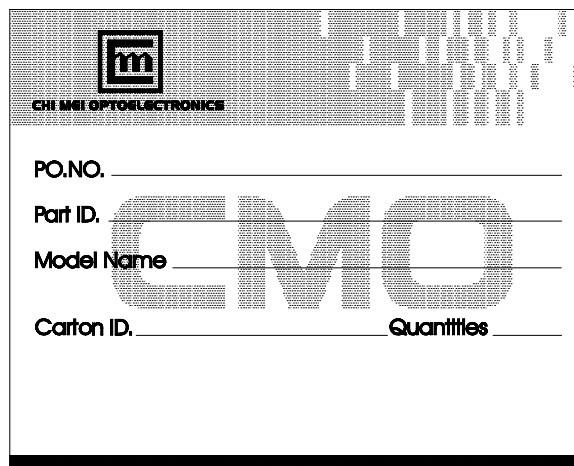

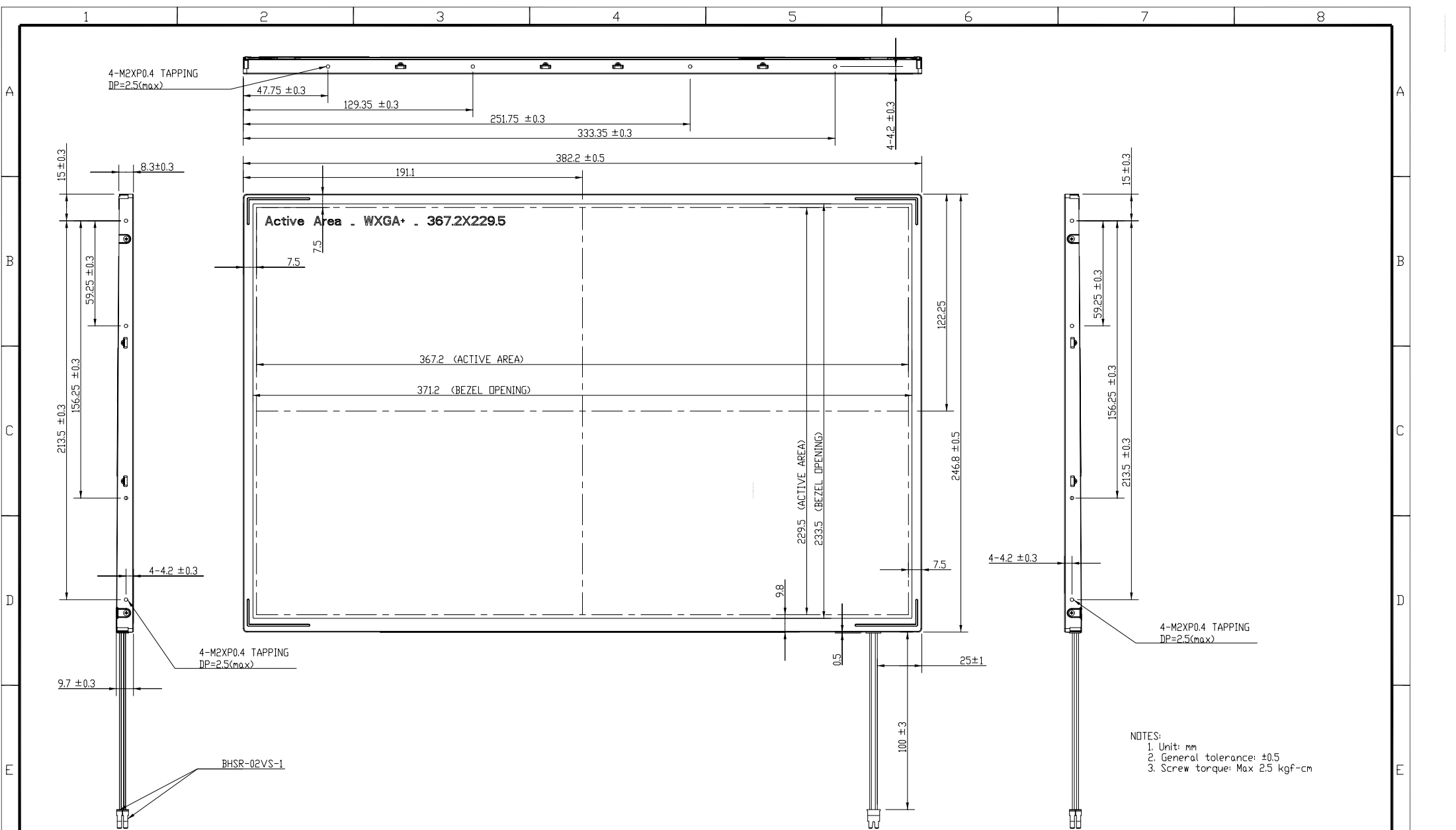

Active Area - WXGA+ - 367.2X229.5

- NOTES:
1. Unit: mm
  2. General tolerance: ±0.5
  3. Screw torque: Max 2.5 kgf-cm

|   |               |                        |             |                                  |             |
|---|---------------|------------------------|-------------|----------------------------------|-------------|
| TITLE                                   |               | ASSY_MODULE_N170C1-L01 |             | 2D REV. 1                        |             |
|   |               |                        |             | 3D REV. 0+                       |             |
| Approved                                | BILL_SHEU     | Drawing No.            | N170141011  |                                  |             |
| Checked                                 | YULE_LIN      | Part No.               | TBD         |                                  |             |
| Drawer                                  | HSINHUNG_CHEN | Material               | TBD         | Sheet                            | 1 / 2 A3    |
| Designer                                | HSINHUNG_CHEN | Date                   | 08-Jan-2005 | Scale                            | 1:1 Unit:mm |
|   |               |                        |             | CHI MEI<br>OPTOELECTRONICS CORP. |             |
| ALL RIGHTS RESERVED, COPYING FORBIDDEN. |               |                        |             |                                  |             |

| Mark | Description | Date | Changed_By | Approved_By | ECN No. | Remark |
|------|-------------|------|------------|-------------|---------|--------|
| 1    |             |      |            |             |         |        |
| 2    |             |      |            |             |         |        |
| 3    |             |      |            |             |         |        |
| 4    |             |      |            |             |         |        |
| 5    |             |      |            |             |         |        |

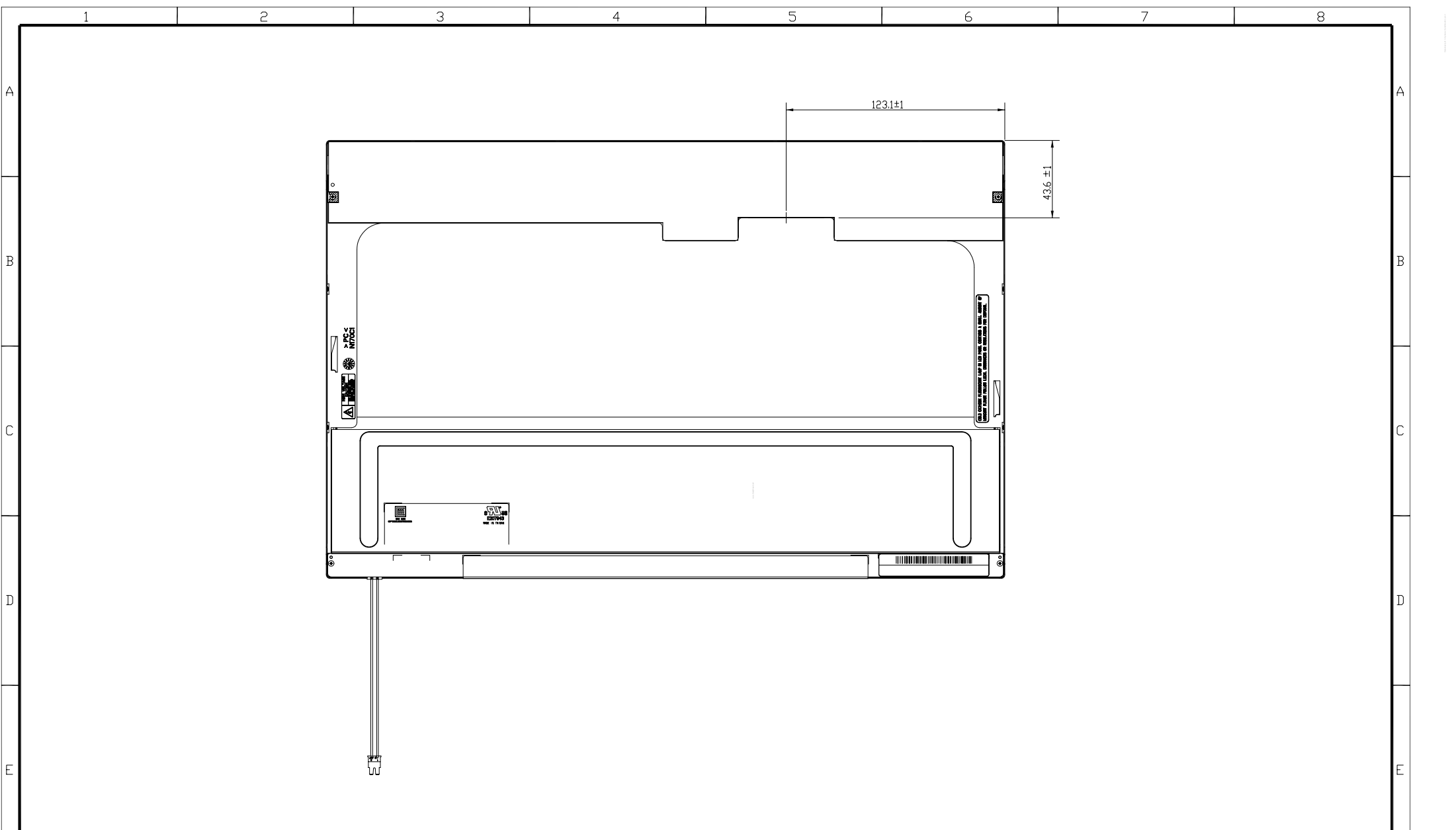

|          |                        |             |             |                   |
|----------|------------------------|-------------|-------------|-------------------|
| TITLE    | ASSY_MODULE_N170C1-L01 |             |             | 2D REV. 1         |
|          |                        |             |             | 3D REV. 0+        |
| Approved | BILL_SHEU              | Drawing No. | N170141011  |                   |
| Checked  | YULE_LIN               | Part No.    | TBD         |                   |
| Drawer   | HSINHUNG_CHEN          | Material    | TBD         | Sheet 2 / 2 A3    |
| Designer | HSINHUNG_CHEN          | Date        | 08-Jan-2005 | Scale 1:1 Unit:mm |

**CHI MEI**  
 OPTOELECTRONICS CORP. ALL RIGHTS RESERVED, COPYING FORBIDDEN.

| Mark | Description | Date | Changed_By | Approved_By | ECN No. | Remark |
|------|-------------|------|------------|-------------|---------|--------|
| 1    |             |      |            |             |         |        |
| 2    |             |      |            |             |         |        |
| 3    |             |      |            |             |         |        |
| 4    |             |      |            |             |         |        |
| 5    |             |      |            |             |         |        |