

TFT LCD Preliminary Specification

MODEL NO.: N170C4 - L01

Customer : _____

Approved by : _____

Note :

記錄	工作	審核	角色	投票
2007-06-15 10:03:01 CST	Approve by Dept. Mgr.(QA RA)	yuan_chan(趙俊淵/52760/54760)	Department Manager(QA RA)	Accept
2007-06-14 08:59:34 CST	Approve by Director	wy_li(李汪洋/44701)	Director	Accept
2007-06-08 17:16:54 CST	Approve by Director	kf_huang(黃崑峰 /56620/54380/14906/25075)	Director	Accept
2007-06-08 14:41:32 CST	Approve by Director	iy_wu(吳震乙/56360/54952)	Director	Accept

- CONTENTS -

REVISION HISTORY	-----	3
1. GENERAL DESCRIPTION	-----	4
1.1 OVERVIEW		
1.2 FEATURES		
1.3 APPLICATION		
1.4 GENERAL SPECIFICATIONS		
1.5 MECHANICAL SPECIFICATIONS		
2. ABSOLUTE MAXIMUM RATINGS	-----	5
2.1 ABSOLUTE RATINGS OF ENVIRONMENT		
2.2 ELECTRICAL ABSOLUTE RATINGS		
2.2.1 TFT LCD MODULE		
2.2.2 BACKLIGHT UNIT		
3. ELECTRICAL CHARACTERISTICS	-----	7
3.1 TFT LCD MODULE		
3.2 BACKLIGHT UNIT		
4. BLOCK DIAGRAM	-----	11
4.1 TFT LCD MODULE		
4.2 BACKLIGHT UNIT		
5. INPUT TERMINAL PIN ASSIGNMENT	-----	12
5.1 TFT LCD MODULE		
5.2 BACKLIGHT UNIT		
5.3 TIMING DIAGRAM OF LVDS INPUT SIGNAL		
5.4 COLOR DATA INPUT ASSIGNMENT		
5.5 EDID CODE DATA STRUCTURE		
6. INTERFACE TIMING	-----	18
6.1 INPUT SIGNAL TIMING SPECIFICATIONS		
6.2 POWER ON/OFF SEQUENCE		
7. OPTICAL CHARACTERISTICS	-----	20
7.1 TEST CONDITIONS		
7.2 OPTICAL SPECIFICATIONS		
8. PRECAUTIONS	-----	23
8.1 ASSEMBLY AND HANDLING PRECAUTIONS		
8.2 SAFETY PRECAUTIONS		
9. PACKING	-----	24
9.1 CARTON		
9.2 PALLET		
10. DEFINITION OF LABELS	-----	25
10.1 CMO MODULE LABEL		
10.2 CMO CARTON LABEL		

REVISION HISTORY

Version	Date	Page (New)	Section	Description
Ver 1.0	Jun 07,2007	All	All	Preliminary Specification is first issued

1. GENERAL DESCRIPTION

1.1 OVERVIEW

N170C4 - L01 is a 17.0" TFT Liquid Crystal Display module with two CCFLs Backlight unit and 30 pins LVDS interface. This module supports 1440 x 900 Wide-XGA+ mode and can display 262,144 colors. The optimum viewing angle is at 6 o'clock direction. The inverter module for Backlight is not built in.

1.2 FEATURES

- Thin and High Brightness
- WXGA+ (1440 x 900 pixels) resolution
- DE only mode
- 3.3V LVDS (Low Voltage Differential Signaling) interface with 2 pixel/clock
- 2 CCFLs

1.3 APPLICATION

- TFT LCD Notebook

1.4 GENERAL SPECIFICATIONS

Item	Specification	Unit	Note
Active Area	367.2 (H) x 229.5 (V) (17.0" diagonal)	mm	(1)
Bezel Opening Area	370.7 (H) x 232.8 (V)	mm	
Driver Element	a-si TFT active matrix	-	-
Pixel Number	1440 x R.G.B. x 900	pixel	-
Pixel Pitch	0.255 (H) x 0.255 (V)	mm	-
Pixel Arrangement	RGB vertical stripe	-	-
Display Colors	262,144	color	-
Transmissive Mode	Normally white	-	-
Surface Treatment	Hard coating (3H), Glare Type	-	-

1.5 MECHANICAL SPECIFICATIONS

Item	Min.	Typ.	Max.	Unit	Note	
Module Size	Horizontal (H)	381.7	382.2	382.7	mm	(1)
	Vertical (V)	247	247.5	248	mm	
	Depth (D)	---	---	7.0	mm	
Weight	---	710	725	g	-	

Note (1) Please refer to the attached drawings for more information of front and back outline dimensions.

2. ABSOLUTE MAXIMUM RATINGS

2.1 ABSOLUTE RATINGS OF ENVIRONMENT

Item	Symbol	Value		Unit	Note
		Min.	Max.		
Storage Temperature	T _{ST}	-20	+60	°C	(1)
Operating Ambient Temperature	T _{OP}	0	+50	°C	(1), (2)
Shock (Non-Operating)	S _{NOP}	-	200/2	G/ms	(3), (5)
Vibration (Non-Operating)	V _{NOP}	-	1.5	G	(4), (5)

Note (1) Temperature and relative humidity range is shown below.

(a) 90 %RH Max. ($T_a \leq 40$ °C).

(b) Wet-bulb temperature should be 39 °C Max. ($T_a > 40$ °C).

(c) No condensation.

Note (2) The temperature of panel display surface area should be 0 °C Min. and 60 °C Max...

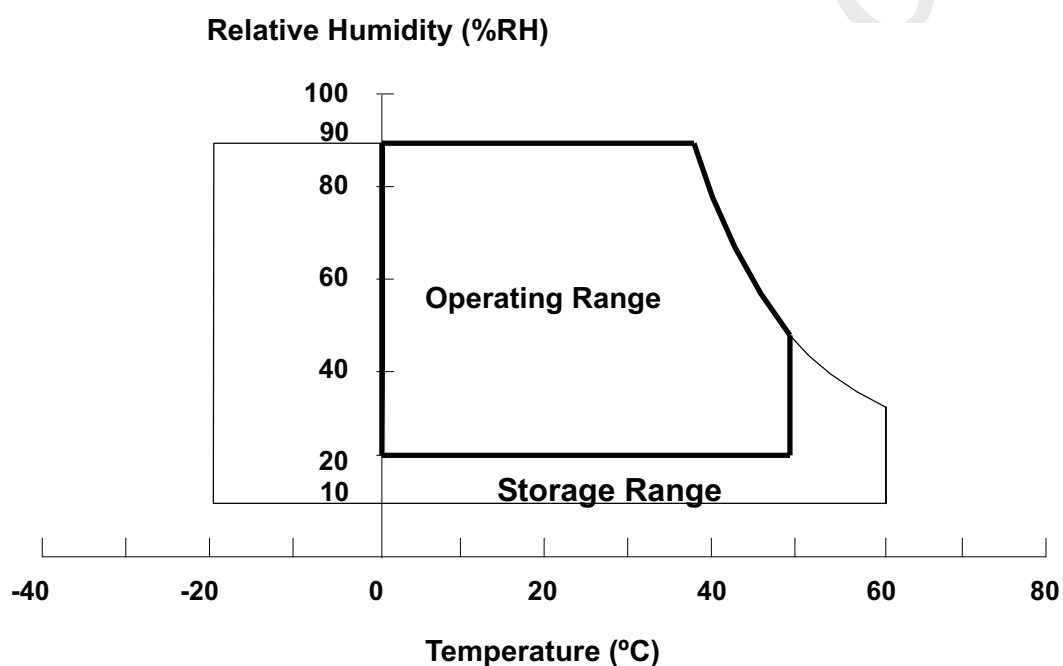

Note (3) 1 time for $\pm X$, $\pm Y$, $\pm Z$. for Condition (200G / 2ms) is half Sine Wave.

Note (4) 10 ~ 500 Hz, 0.5 Hr / Cycle, 1 cycles for each X, Y, Z axis.

Note (5) At testing Vibration and Shock, the fixture in holding the module has to be hard and rigid enough so that the module would not be twisted or bent by the fixture.

The fixing condition is shown as below:

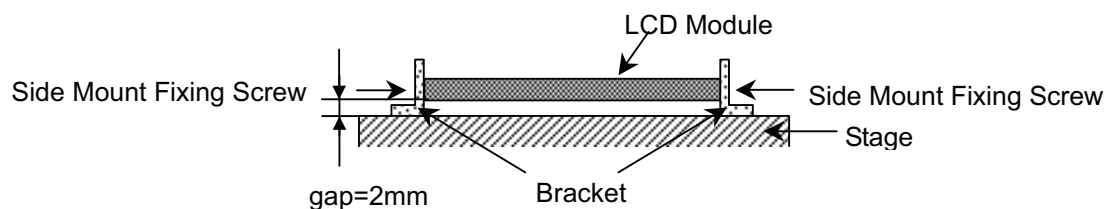

2.2 ELECTRICAL ABSOLUTE RATINGS

2.2.1 TFT LCD MODULE

Item	Symbol	Value		Unit	Note
		Min.	Max.		
Power Supply Voltage	V_{CC}	-0.3	+4.0	V	(1)
Logic Input Voltage	V_{IN}	-0.3	$V_{CC}+0.3$	V	

2.2.2 BACKLIGHT UNIT

Item	Symbol	Value		Unit	Note
		Min.	Max.		
Lamp Voltage	V_L	—	2.5K	V_{RMS}	(1), (2), $I_L = 6.0$ mA
Lamp Current	I_L	—	(6.0)	mA_{RMS}	(1), (2)
Lamp Frequency	F_L	—	80	KHZ	

Note (1) Permanent damage to the device may occur if maximum values are exceeded. Function operation should be restricted to the conditions described under Normal Operating Conditions.

Note (2) Specified values are for lamp (Refer to 3.2 for further information).

3. ELECTRICAL CHARACTERISTICS

3.1 TFT LCD MODULE

 $T_a = 25 \pm 2 \text{ }^\circ\text{C}$

Parameter	Symbol	Value			Unit	Note
		Min.	Typ.	Max.		
Power Supply Voltage	V _{CC}	3.0	3.3	3.6	V	-
Permissible Ripple Voltage	V _{RP}		100		mV	-
Rush Current	I _{RUSH}			1.5	A	(2)
Initial Stage Current	I _{IS}			1.0	A	(2)
Power Supply Current	White		(450)	(480)	mA	(3)a
	Black		(570)	(600)	mA	(3)b
LVDS Differential Input High Threshold	V _{TH(LVDS)}			+100	mV	(5), V _{CM} =1.2V
LVDS Differential Input Low Threshold	V _{TL(LVDS)}	-100			mV	(5) V _{CM} =1.2V
LVDS Common Mode Voltage	V _{CM}	1.125		1.375	V	(5)
LVDS Differential Input Voltage	V _{ID}	100		600	mV	(5)
Terminating Resistor	R _T		100		Ohm	
Power per EBL WG	P _{EBL}	-	(4.52)	-	W	(4)

Note (1) The module should be always operated within above ranges.

Note (2) I_{RUSH}: the maximum current when V_{CC} is rising

I_{IS}: the maximum current of the first 100ms after power-on

Measurement Conditions: Shown as the following figure. Test pattern: black.

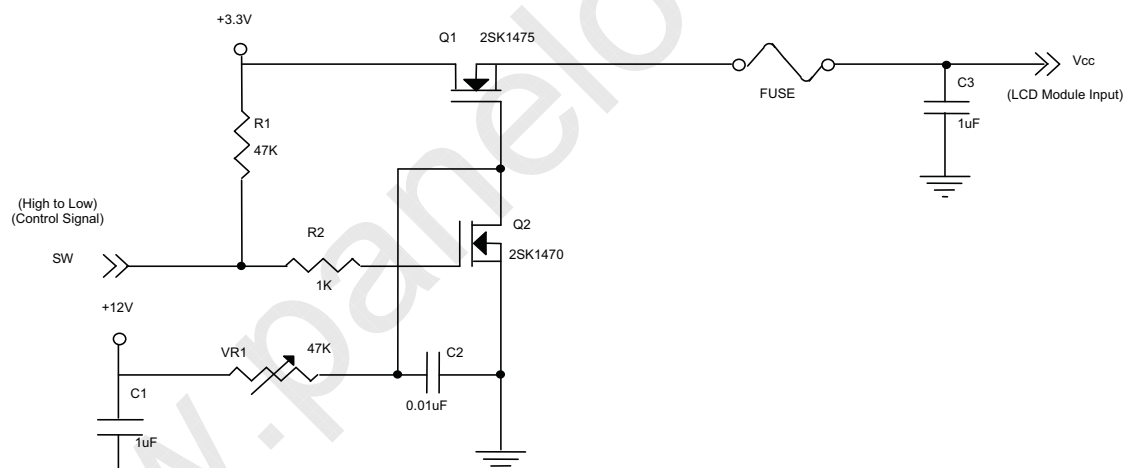

Vcc rising time is 470us

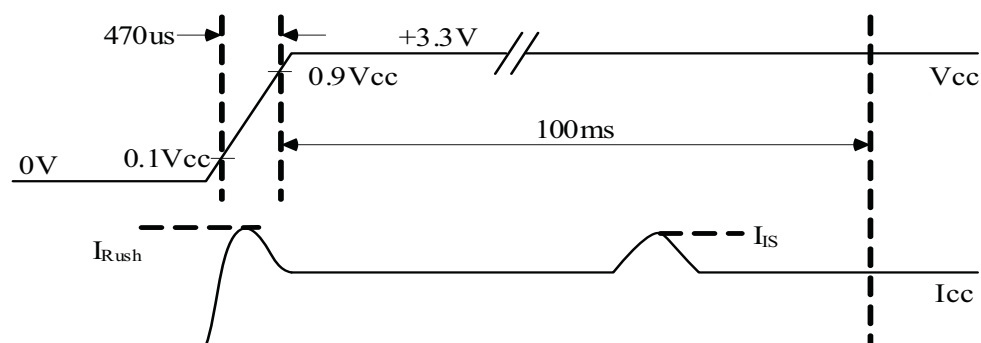

Note (3) The specified power supply current is under the conditions at $V_{CC} = 3.3\text{ V}$, $T_a = 25 \pm 2\text{ }^\circ\text{C}$, $f_v = 60\text{ Hz}$, whereas a power dissipation check pattern below is displayed.

a. White Pattern



Active Area

b. Black Pattern

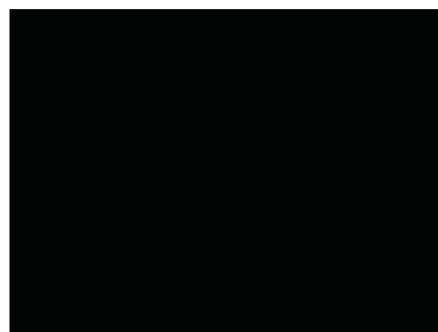

Active Area

Note (4) The specified power are the sum of LCD panel electronics input power and the inverter input power. Test conditions are as follows.

- $V_{CC} = 3.3\text{ V}$, $T_a = 25 \pm 2\text{ }^\circ\text{C}$, $f_v = 60\text{ Hz}$,
- The pattern used is a black and white 32 x 36 checkerboard, slide #100 from the VESA file "Flat Panel Display Monitor Setup Patterns", FPDMSU.ppt.
- Luminance: 60 nits.
- The inverter used is provided from Sumida. Please contact them for detail information. CMO doesn't provide the inverter in this product.

Note (5) The parameters of LVDS signals are defined as the following figures.

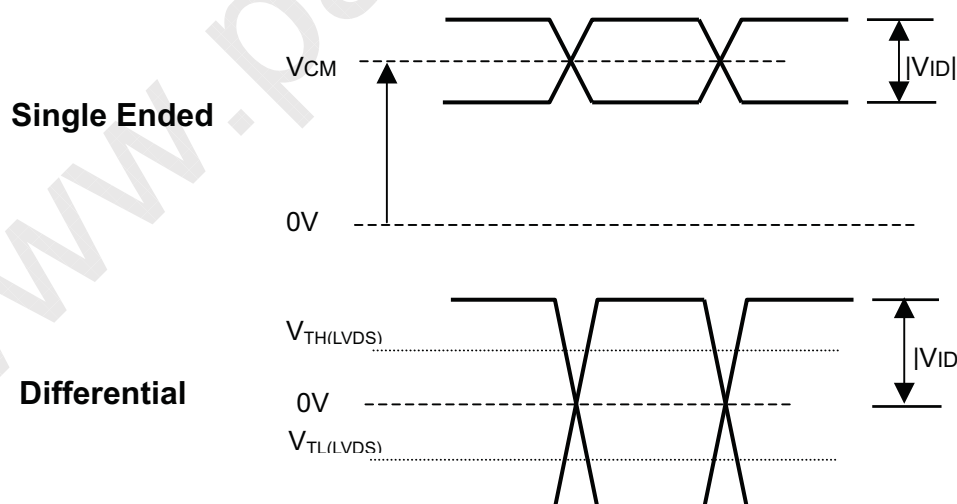

3.2 BACKLIGHT UNIT

Ta = 25 ± 2 °C

Parameter	Symbol	Value			Unit	Note
		Min.	Typ.	Max.		
Lamp Input Voltage	V _L	(675)	(750)	(825)	V _{RMS}	I _L = 6.0 mA
Lamp Current	I _L	(2.0)	(6.0)	(6.5)	mA _{RMS}	(1)
Lamp Turn On Voltage	V _S	—	—	(1290) (25 °C)	V _{RMS}	(2)
		—	—	(1560) (0 °C)	V _{RMS}	(2)
Operating Frequency	F _L	50	—	80	KHz	(3)
Lamp Life Time	L _{BL}	(12,000)	—	—	Hrs	(5)
Power Consumption	P _L	—	(9.0)	—	W	(4), I _L = 6.0 mA

Note (1) Lamp current is measured by utilizing a high frequency current meter as shown below:

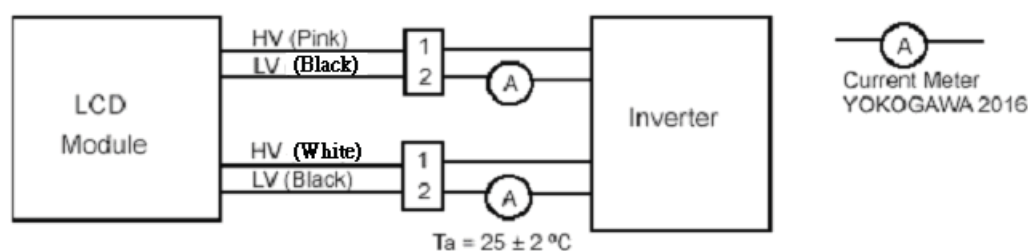

Note (2) The voltage shown above should be applied to the lamp for more than 1 second after startup. Otherwise the lamp may not be turned on.

Note (3) The lamp frequency may produce interference with horizontal synchronous frequency from the display, and this may cause line flow on the display. In order to avoid interference, the lamp frequency should be detached from the horizontal synchronous frequency and its harmonics as far as possible.

Note (4) $P_L = I_L \times V_L \times 2$

Note (5) The lifetime of lamp is defined as the time when it continues to operate under the conditions at Ta = 25 ± 2 °C and I_L = 6.0 mA_{RMS} until one of the following events occurs:

(a) When the brightness becomes ≤ 50% of its original value.

(b) When the effective ignition length becomes ≤ 80% of its original value. (Effective ignition length is defined as an area that the brightness is less than 70% compared to the center point.)

Note (6) The waveform of the voltage output of inverter must be area-symmetric and the design of the inverter must have specifications for the modularized lamp. The performance of the Backlight, such as lifetime or brightness, is greatly influenced by the characteristics of the DC-AC inverter for the lamp. All the parameters of an inverter should be carefully designed to avoid generating too much current leakage from high voltage output of the inverter. When designing or ordering the inverter please make sure that a poor lighting caused by the mismatch of the Backlight and the inverter (miss-lighting, flicker, etc.) never occurs. If the above situation is confirmed, the module

should be operated in the same manners when it is installed in your instrument.

Requirements for a system inverter design, which is intended to have a better display performance, a better power efficiency and a more reliable lamp. It shall help increase the lamp lifetime and reduce its leakage current.

- The asymmetry rate of the inverter waveform should be 10% below;
- The distortion rate of the waveform should be within $\sqrt{2} \pm 10\%$;
- The ideal sine wave form shall be symmetric in positive and negative polarities.

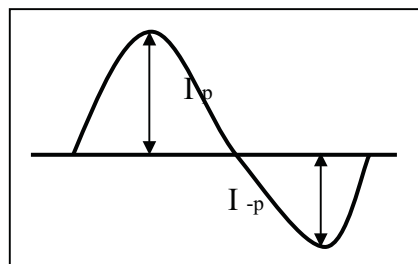

* Asymmetry rate:

$$|I_p - I_{-p}| / I_{rms} * 100\%$$

* Distortion rate

$$I_p \text{ (or } I_{-p}) / I_{rms}$$

4. BLOCK DIAGRAM

4.1 TFT LCD MODULE

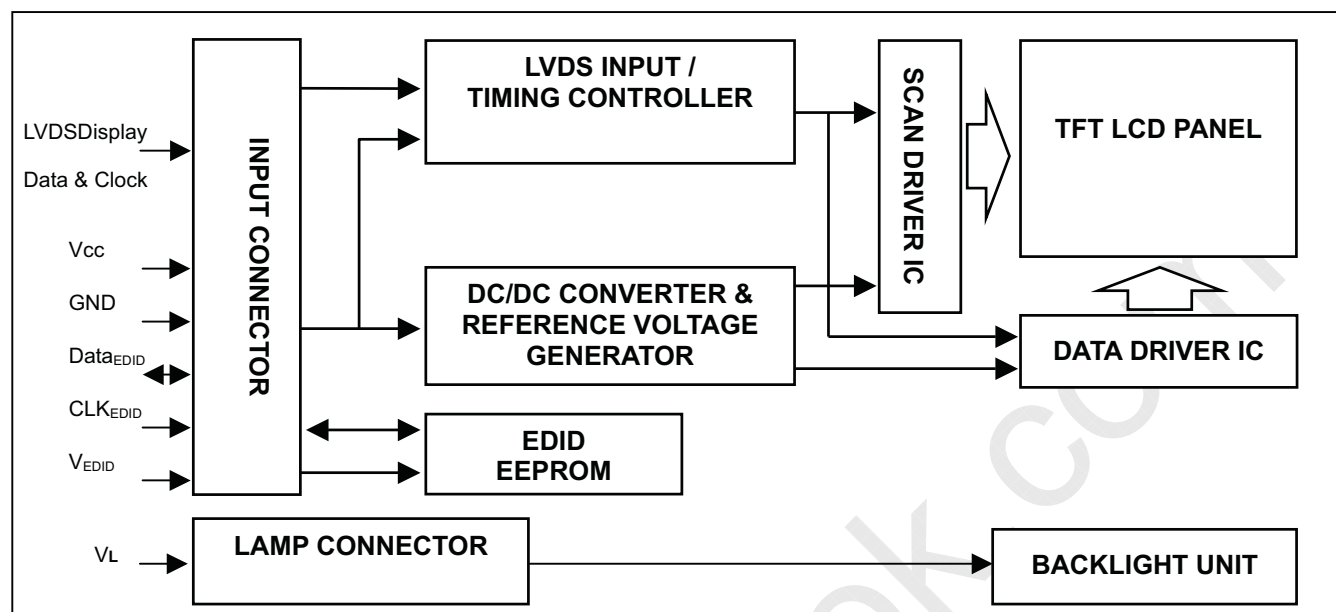

4.2 BACKLIGHT UNIT

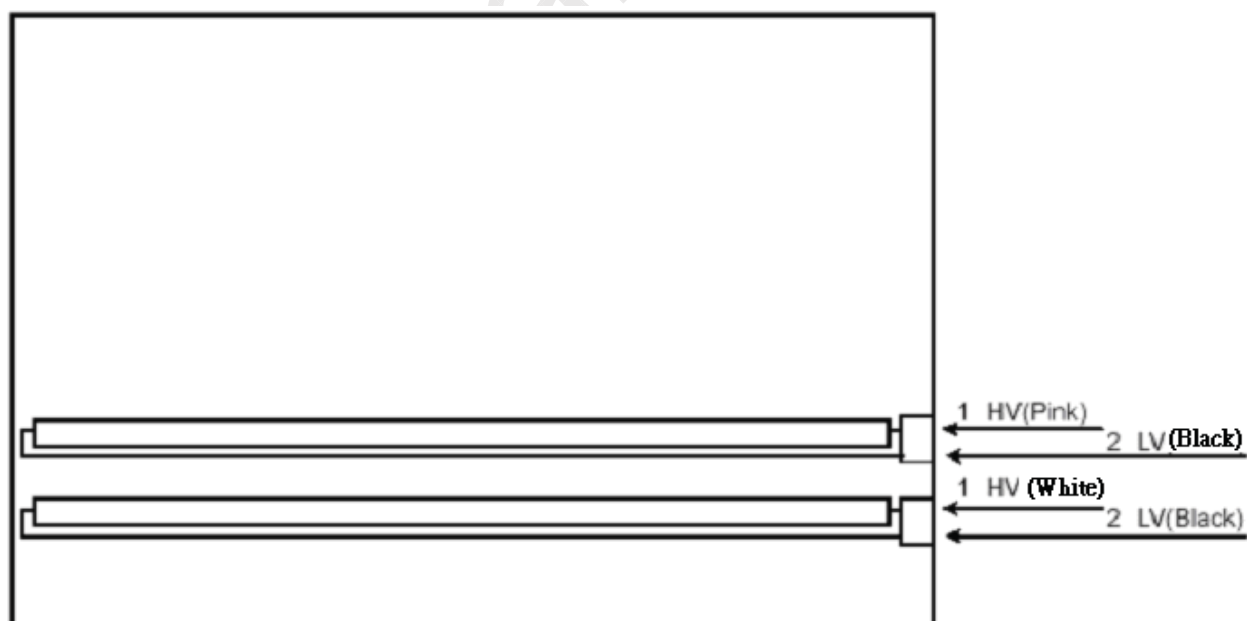

5. INPUT TERMINAL PIN ASSIGNMENT

5.1 TFT LCD MODULE

Pin	Symbol	Description	Polarity	Remark
1	Vss	Ground		
2	Vcc	Power Supply +3.3 V (typical)		
3	Vcc	Power Supply +3.3 V (typical)		
4	V _{EDID}	DDC 3.3V Power		
5	NC	Non-Connection		
6	CLK _{EDID}	DDC Clock		
7	DATA _{EDID}	DDC Data		
8	RXO0-	LVDS Differential Data Input (Odd)	Negative	
9	RXO0+	LVDS Differential Data Input (Odd)	Positive	
10	Vss	Ground		
11	RXO1-	LVDS Differential Data Input (Odd)	Negative	
12	RXO1+	LVDS Differential Data Input (Odd)	Positive	
13	Vss	Ground		
14	RXO2-	LVDS Differential Data Input (Odd)	Negative	
15	RXO2+	LVDS Differential Data Input (Odd)	Positive	
16	Vss	Ground		
17	RXOC-	LVDS Clock Data Input (Odd)	Negative	
18	RXOC+	LVDS Clock Data Input (Odd)	Positive	
19	Vss	Ground		
20	RxE0-	LVDS Differential Data Input (Even)	Negative	
21	RxE0+	LVDS Differential Data Input (Even)	Positive	
22	Vss	Ground		
23	RxE1-	LVDS Differential Data Input (Even)	Negative	
24	RxE1+	LVDS Differential Data Input (Even)	Positive	
25	Vss	Ground		
26	RxE2-	LVDS Differential Data Input (Even)	Negative	
27	RxE2+	LVDS Differential Data Input (Even)	Positive	
28	Vss	Ground		
29	RXEC-	LVDS Clock Data Input (Even)	Negative	
30	RXEC+	LVDS Clock Data Input (Even)	Positive	

Note (1) Connector Part No.: JAE-FI-XB30SRL-HF11 or equivalent

Note (2) User's connector Part No: JAE-FI-X30C2L or equivalent

Note (3) The first pixel is odd as shown in the following figure.

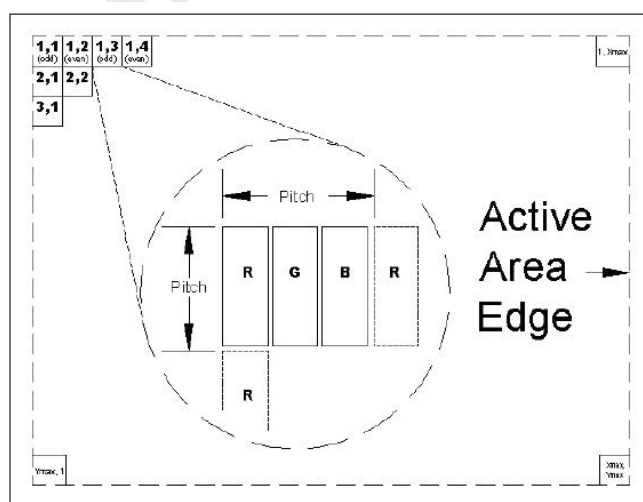

5.2 BACKLIGHT UNIT

Pin	Symbol	Description	Color
1	HV	High Voltage	Pink
2	LV	Ground	Black
1	HV	High Voltage	White
2	LV	Ground	Black

Note (1) Connector Part No.: JST-BHSR-02VS-1 or equivalent

Note (2) User's connector Part No.: JST-SM02B-BHSS-1-TB or equivalent

5.3 TIMING DIAGRAM OF LVDS INPUT SIGNAL

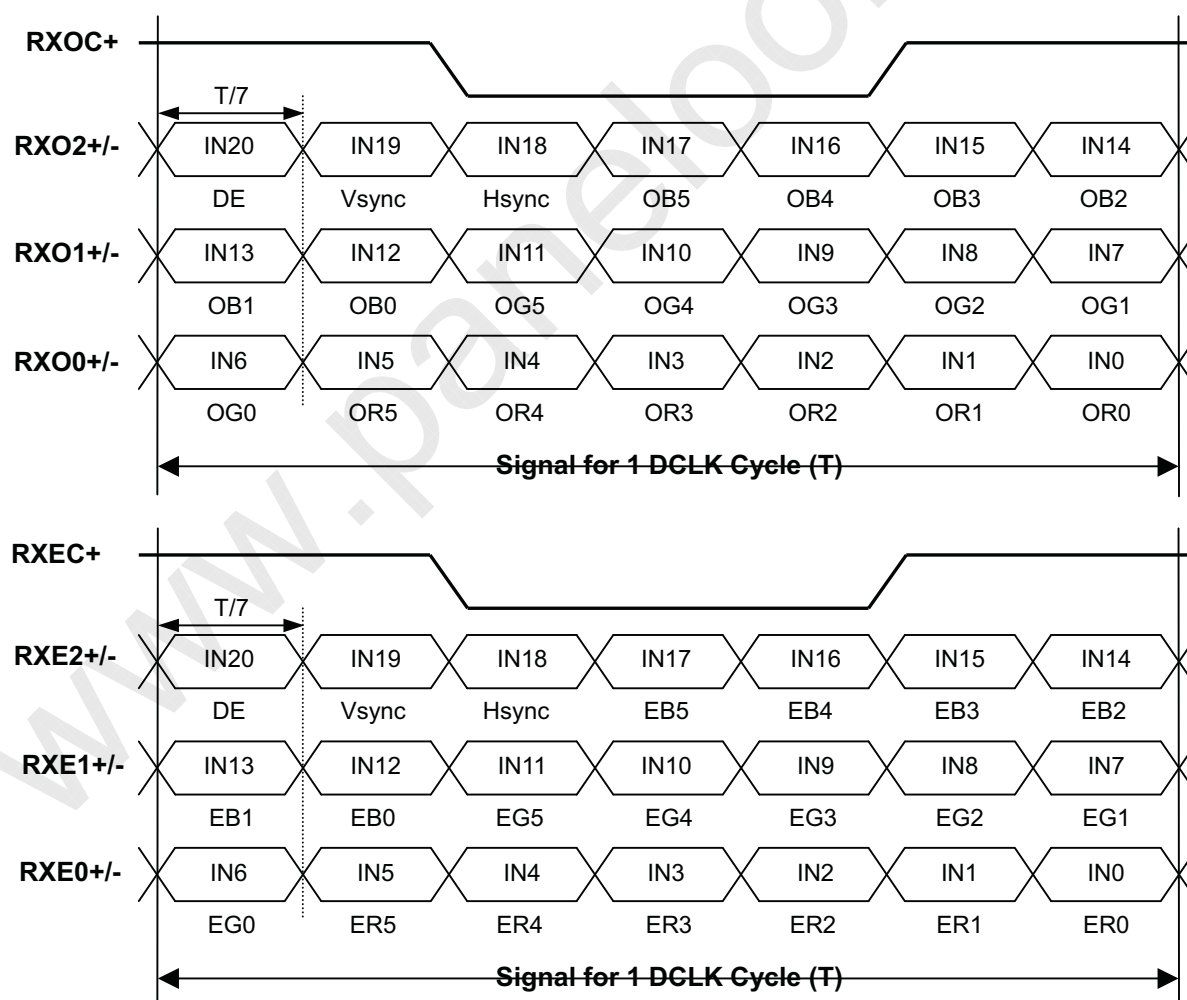

5.4 COLOR DATA INPUT ASSIGNMENT

The brightness of each primary color (red, green and blue) is based on the 6-bit gray scale data input for the color. The higher the binary input, the brighter the color. The table below provides the assignment of color versus data input.

Color		Data Signal																	
		Red						Green						Blue					
		R5	R4	R3	R2	R1	R0	G5	G4	G3	G2	G1	G0	B5	B4	B3	B2	B1	B0
Basic Colors	Black	0	0	0	0	0	0	0	0	0	0	0	0	0	0	0	0	0	0
	Red	1	1	1	1	1	1	0	0	0	0	0	0	0	0	0	0	0	0
	Green	0	0	0	0	0	0	1	1	1	1	1	1	0	0	0	0	0	0
	Blue	0	0	0	0	0	0	0	0	0	0	0	0	1	1	1	1	1	1
	Cyan	0	0	0	0	0	0	1	1	1	1	1	1	1	1	1	1	1	1
	Magenta	1	1	1	1	1	1	0	0	0	0	0	0	0	1	1	1	1	1
	Yellow	1	1	1	1	1	1	1	1	1	1	1	1	0	0	0	0	0	0
	White	1	1	1	1	1	1	1	1	1	1	1	1	1	1	1	1	1	1
Gray Scale Of Red	Red(0)/Dark	0	0	0	0	0	0	0	0	0	0	0	0	0	0	0	0	0	0
	Red(1)	0	0	0	0	0	1	0	0	0	0	0	0	0	0	0	0	0	0
	Red(2)	0	0	0	0	1	0	0	0	0	0	0	0	0	0	0	0	0	0
	:	:	:	:	:	:	:	:	:	:	:	:	:	:	:	:	:	:	:
	:	:	:	:	:	:	:	:	:	:	:	:	:	:	:	:	:	:	:
	:	:	:	:	:	:	:	:	:	:	:	:	:	:	:	:	:	:	:
	Red(61)	1	1	1	1	0	1	0	0	0	0	0	0	0	0	0	0	0	0
	Red(62)	1	1	1	1	1	0	0	0	0	0	0	0	0	0	0	0	0	0
Red(63)	1	1	1	1	1	1	0	0	0	0	0	0	0	0	0	0	0	0	
Gray Scale Of Green	Green(0)/Dark	0	0	0	0	0	0	0	0	0	0	0	0	0	0	0	0	0	0
	Green(1)	0	0	0	0	0	0	0	0	0	0	0	1	0	0	0	0	0	0
	Green(2)	0	0	0	0	0	0	0	0	0	0	1	0	0	0	0	0	0	0
	:	:	:	:	:	:	:	:	:	:	:	:	:	:	:	:	:	:	:
	:	:	:	:	:	:	:	:	:	:	:	:	:	:	:	:	:	:	:
	:	:	:	:	:	:	:	:	:	:	:	:	:	:	:	:	:	:	:
	Green(61)	0	0	0	0	0	0	1	1	1	1	0	1	0	0	0	0	0	0
	Green(62)	0	0	0	0	0	0	1	1	1	1	1	0	0	0	0	0	0	0
Green(63)	0	0	0	0	0	0	1	1	1	1	1	1	0	0	0	0	0	0	
Gray Scale Of Blue	Blue(0)/Dark	0	0	0	0	0	0	0	0	0	0	0	0	0	0	0	0	0	0
	Blue(1)	0	0	0	0	0	0	0	0	0	0	0	0	0	0	0	0	0	1
	Blue(2)	0	0	0	0	0	0	0	0	0	0	0	0	0	0	0	0	1	0
	:	:	:	:	:	:	:	:	:	:	:	:	:	:	:	:	:	:	:
	:	:	:	:	:	:	:	:	:	:	:	:	:	:	:	:	:	:	:
	:	:	:	:	:	:	:	:	:	:	:	:	:	:	:	:	:	:	:
	Blue(61)	0	0	0	0	0	0	0	0	0	0	0	0	1	1	1	1	0	1
	Blue(62)	0	0	0	0	0	0	0	0	0	0	0	0	1	1	1	1	1	0
Blue(63)	0	0	0	0	0	0	0	0	0	0	0	0	1	1	1	1	1	1	

Note (1) 0: Low Level Voltage, 1: High Level Voltage

5.5 EDID DATA STRUCTURE

The EDID (Extended Display Identification Data) data formats are to support displays as defined in the VESA Plug & Display and FPD1 standards.

Byte # (decimal)	Byte # (hex)	Field Name and Comments	Value (hex)	Value (binary)
1	0	Header	00	00000000
2	1	Header	FF	11111111
3	2	Header	FF	11111111
4	3	Header	FF	11111111
5	4	Header	FF	11111111
6	5	Header	FF	11111111
7	6	Header	FF	11111111
8	7	Header	00	00000000
9	8	EISA ID manufacturer name ("CMO")	0D	00001101
10	9	EISA ID manufacturer name (Compressed ASCII)	AF	10101111
11	0A	ID product code (N170C4-L01)	06	00000110
12	0B	ID product code (hex LSB first; N170C4-L01)	17	00010111
13	0C	ID S/N (fixed "0")	00	00000000
14	0D	ID S/N (fixed "0")	00	00000000
15	0E	ID S/N (fixed "0")	00	00000000
16	0F	ID S/N (fixed "0")	00	00000000
17	10	Week of manufacture (fixed week code)	28	00101000
18	11	Year of manufacture (fixed year code)	0C	00001100
19	12	EDID structure version # ("1")	01	00000001
20	13	EDID revision # ("3")	03	00000011
21	14	Video I/P definition ("digital")	80	10000000
22	15	Max H image size ("36.72 cm")	25	00100101
23	16	Max V image size ("22.95 cm")	17	00010111
24	17	Display Gamma (Gamma = "2.2")	78	01111000
25	18	Feature support ("Active off, RGB Color")	0A	00001010
26	19	Red/Green (Rx1, Rx0, Ry1, Ry0, Gx1, Gx0, Gy1, Gy0)	FA	11111010
27	1A	Blue/White (Bx1, Bx0, By1, By0, Wx1, Wx0, Wy1, Wy0)	1D	00011101
28	1B	Red-x (Rx = "0.648")	A5	10100101
29	1C	Red-y (Ry = "0.347")	58	01011000
30	1D	Green-x (Gx = "0.283")	48	01001000
31	1E	Green-y (Gy = "0.611")	9C	10011100
32	1F	Blue-x (Bx = "0.141")	24	00100100
33	20	Blue-y (By = "0.071")	12	00010010
34	21	White-x (Wx = "0.319")	51	01010001
35	22	White-y (Wy = "0.333")	55	01010101
36	23	Established timings 1	00	00000000
37	24	Established timings 2	00	00000000
38	25	Manufacturer's reserved timings	00	00000000
39	26	Standard timing ID # 1	01	00000001

40	27	Standard timing ID # 1	01	00000001
41	28	Standard timing ID # 2	01	00000001
42	29	Standard timing ID # 2	01	00000001
43	2A	Standard timing ID # 3	01	00000001
44	2B	Standard timing ID # 3	01	00000001
45	2C	Standard timing ID # 4	01	00000001
46	2D	Standard timing ID # 4	01	00000001
47	2E	Standard timing ID # 5	01	00000001
48	2F	Standard timing ID # 5	01	00000001
49	30	Standard timing ID # 6	01	00000001
50	31	Standard timing ID # 6	01	00000001
51	32	Standard timing ID # 7	01	00000001
52	33	Standard timing ID # 7	01	00000001
53	34	Standard timing ID # 8	01	00000001
54	35	Standard timing ID # 8	01	00000001
55	36	Detailed timing description # 1 Pixel clock ("88.75 MHz")	AB	10101011
56	37	# 1 Pixel clock (hex LSB first)	22	00100010
57	38	# 1 H active ("1440")	A0	10100000
58	39	# 1 H blank ("160")	A0	10100000
59	3A	# 1 H active : H blank ("1440 : 160")	50	01010000
60	3B	# 1 V active ("900")	84	10000100
61	3C	# 1 V blank ("26")	1A	00011010
62	3D	# 1 V active : V blank ("900 : 26")	30	00110000
63	3E	# 1 H sync offset ("48")	30	00110000
64	3F	# 1 H sync pulse width ("32")	20	00100000
65	40	# 1 V sync offset : V sync pulse width ("3 : 6")	36	00110110
66	41	# 1 H sync offset : H sync pulse width : V sync offset : V sync width ("48 : 32 : 3 : 6")	00	00000000
67	42	# 1 H image size ("367 mm")	6F	01101111
68	43	# 1 V image size ("230 mm")	E6	11100110
69	44	# 1 H image size : V image size ("367 : 230")	10	00010000
70	45	# 1 H boarder ("0")	00	00000000
71	46	# 1 V boarder ("0")	00	00000000
72	47	# 1 Non-interlaced, Normal, no stereo, Separate sync, H/V pol Negatives	18	00011000
73	48	Detailed timing description # 2	00	00000000
74	49	# 2 Flag	00	00000000
75	4A	# 2 Reserved	00	00000000
76	4B	# 2 FE (hex) defines ASCII string (Model Name "N170C4-L01", ASCII)	FE	11111110
77	4C	# 2 Flag	00	00000000
78	4D	# 2 1st character of name ("N")	4E	01001110
79	4E	# 2 2nd character of name ("1")	31	00110001
80	4F	# 2 3rd character of name ("7")	37	00110111
81	50	# 2 4th character of name ("0")	30	00110000
82	51	# 2 5th character of name ("C")	43	01000011
83	52	# 2 6th character of name ("4")	34	00110100
84	53	# 2 7th character of name ("-")	2D	00101101
85	54	# 2 8th character of name ("L")	4C	01001100
86	55	# 2 9th character of name ("0")	30	00110000
87	56	# 2 10th character of name ("1")	31	00110001
88	57	(If <13 char, then terminate with ASCII code 0Ah, set remaining char = 20h)	0A	00001010

89	58	(If <13 char, then terminate with ASCII code 0Ah, set remaining char = 20h)	20	00100000
90	59	(If <13 char, then terminate with ASCII code 0Ah, set remaining char = 20h)	20	00100000
91	5A	Detailed timing description # 3	00	00000000
92	5B	# 3 Flag	00	00000000
93	5C	# 3 Reserved	00	00000000
94	5D	# 3 FE (hex) defines ASCII string (Vendor "CMO", ASCII)	FE	11111110
95	5E	# 3 Flag	00	00000000
96	5F	# 3 1st character of string ("C")	43	01000011
97	60	# 3 2nd character of string ("M")	4D	01001101
98	61	# 3 3rd character of string ("O")	4F	01001111
99	62	(If <13 char, then terminate with ASCII code 0Ah, set remaining char = 20h)	0A	00001010
100	63	(If <13 char, then terminate with ASCII code 0Ah, set remaining char = 20h)	20	00100000
			20	00100000
101	64	(If <13 char, then terminate with ASCII code 0Ah, set remaining char = 20h)		
102	65	(If <13 char, then terminate with ASCII code 0Ah, set remaining char = 20h)	20	00100000
103	66	(If <13 char, then terminate with ASCII code 0Ah, set remaining char = 20h)	20	00100000
104	67	(If <13 char, then terminate with ASCII code 0Ah, set remaining char = 20h)	20	00100000
105	68	(If <13 char, then terminate with ASCII code 0Ah, set remaining char = 20h)	20	00100000
106	69	(If <13 char, then terminate with ASCII code 0Ah, set remaining char = 20h)	20	00100000
107	6A	(If <13 char, then terminate with ASCII code 0Ah, set remaining char = 20h)	20	00100000
108	6B	(If <13 char, then terminate with ASCII code 0Ah, set remaining char = 20h)	20	00100000
109	6C	Detailed timing description # 4	00	00000000
110	6D	# 4 Flag	00	00000000
111	6E	# 4 Reserved	00	00000000
112	6F	# 4 FE (hex) defines ASCII string (Model Name"N170C4-L01", ASCII)	FE	11111110
113	70	# 4 Flag	00	00000000
114	71	# 4 1st character of name ("N")	4E	01001110
115	72	# 4 2nd character of name ("1")	31	00110001
116	73	# 4 3rd character of name ("7")	37	00110111
117	74	# 4 4th character of name ("0")	30	00110000
118	75	# 4 5th character of name ("C")	43	01000011
119	76	# 4 6th character of name ("4")	34	00110100
120	77	# 4 7th character of name ("-")	2D	00101101
121	78	# 4 8th character of name ("L")	4C	01001100
122	79	# 4 9th character of name ("0")	30	00110000
123	7A	# 4 10th character of name ("1")	31	00110001
124	7B	(If <13 char, then terminate with ASCII code 0Ah, set remaining char = 20h)	0A	00001010
125	7C	(If <13 char, then terminate with ASCII code 0Ah, set remaining char = 20h)	20	00100000
126	7D	(If <13 char, then terminate with ASCII code 0Ah, set remaining char = 20h)	20	00100000
127	7E	Extension flag	00	00000000
128	7F	Checksum	A0	10100000

6. INTERFACE TIMING

6.1 INPUT SIGNAL TIMING SPECIFICATIONS

The input signal timing specifications are shown as the following table and timing diagram.

Signal	Item	Symbol	Min.	Typ.	Max.	Unit	Note
DCLK	Frequency	1/Tc	42	44.5	52	MHz	(2)
DE	Vertical Total Time	TV	910	926	980	TH	-
	Vertical Active Display Period	TVD	900	900	900	TH	-
	Vertical Active Blanking Period	TVB	TV-TVD	26	TV-TVD	TH	
	Horizontal Total Time	TH	760	800	880	Tc	(2)
	Horizontal Active Display Period	THD	720	720	720	Tc	(2)
	Horizontal Active Blanking Period	THB	TH-THD	80	TH-THD	Tc	(2)

Note (1) Because this module is operated by DE only mode, Hsync and Vsync are ignored.

(2) 2 channels LVDS input.

INPUT SIGNAL TIMING DIAGRAM

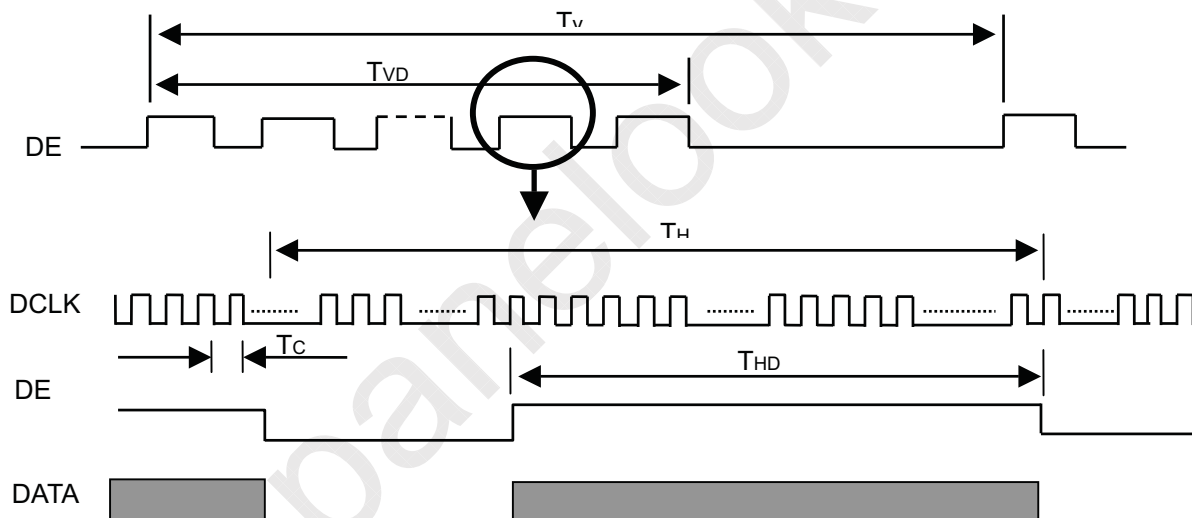

6.2 POWER ON/OFF SEQUENCE

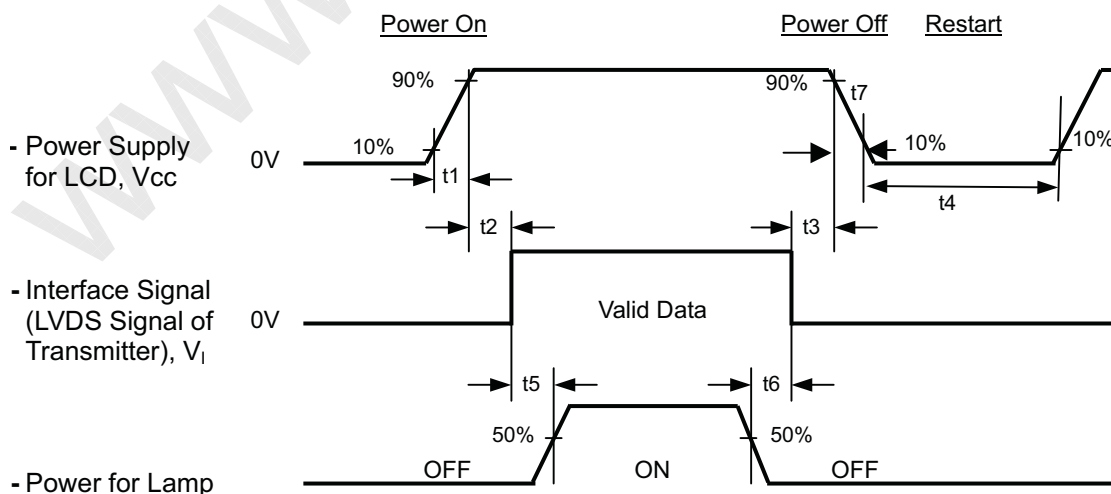

Timing Specifications:

$$0.5 \leq t1 \leq 10 \text{ ms}$$

$$0 \leq t2 \leq 50 \text{ ms}$$

$$0 \leq t3 \leq 50 \text{ ms}$$

$$t4 \geq 500 \text{ ms}$$

$$t5 \geq 200 \text{ ms}$$

$$t6 \geq 200 \text{ ms}$$

Note (1) Please avoid floating state of interface signal at invalid period.

Note (2) When the interface signal is invalid, be sure to pull down the power supply of LCD Vcc to 0 V.

Note (3) The Backlight inverter power must be turned on after the power supply for the logic and the interface signal is valid. The Backlight inverter power must be turned off before the power supply for the logic and the interface signal is invalid.

Note (4) Sometimes some slight noise shows when LCD is turned off (even backlight is already off). To avoid this phenomenon, we suggest that the Vcc falling time is better to follow $5 \leq t7 \leq 300 \text{ ms}$.

7. OPTICAL CHARACTERISTICS

7.1 TEST CONDITIONS

Item	Symbol	Value	Unit
Ambient Temperature	Ta	25±2	°C
Ambient Humidity	Ha	50±10	%RH
Supply Voltage	V _{CC}	3.3	V
Input Signal	According to typical value in "3. ELECTRICAL CHARACTERISTICS"		
Inverter Current	I _L	(6.0)	mA
Inverter Driving Frequency	F _L	(61)	KHz
Inverter	(Darfon VK.12164.101)		

The relative measurement methods of optical characteristics are shown in 7.2. The following items should be measured under the test conditions described in 7.1 and stable environment shown in Note (6).

7.2 OPTICAL SPECIFICATIONS

Item		Symbol	Condition	Min.	Typ.	Max.	Unit	Note	
Contrast Ratio		CR	$\theta_x=0^\circ, \theta_y=0^\circ$ Viewing Normal Angle	(450)	(600)	-	-	(2), (5)	
Response Time		T _R		-	(3)	(8)	ms	(3)	
		T _F		-	(7)	(12)	ms		
Central Luminance of White		L _C		(240)	(300)		cd/m ²	(4), (5)	
White Variation		δW 5pts		-	-	(1.40)	-	(5), (6)	
Color Chromaticity	Red	R _x		Viewing Normal Angle	TYP -0.03	(0.643)	TYP +0.03	-	(1)
		R _y				(0.349)		-	
	Green	G _x				(0.281)		-	
		G _y				(0.609)		-	
	Blue	B _x				(0.142)		-	
		B _y	(0.068)			-			
	White	W _x	0.313			-			
		W _y	0.329			-			
Viewing Angle	Horizontal	θ_{x+}	CR≥10	(60)	(70)	-	Deg.		
		θ_{x-}		(60)	(70)	-			
	Vertical	θ_{y+}		(50)	(60)	-			
		θ_{y-}		(50)	(60)	-			

Note (1) Definition of Viewing Angle (θ_x , θ_y):

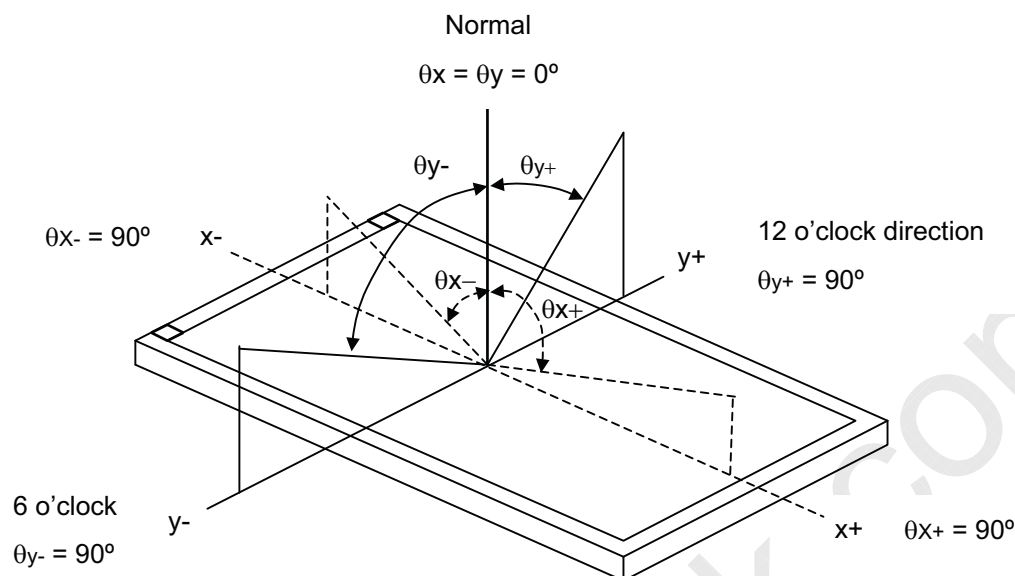

Note (2) Definition of Contrast Ratio (CR):

The contrast ratio can be calculated by the following expression.

$$\text{Contrast Ratio (CR)} = L_{63} / L_0$$

L63: Luminance of gray level 63

L 0: Luminance of gray level 0

$$\text{CR} = \text{CR} (5)$$

CR (X) is corresponding to the Contrast Ratio of the point X at Figure in Note (5).

Note (3) Definition of Response Time (T_R , T_F) and measurement method:

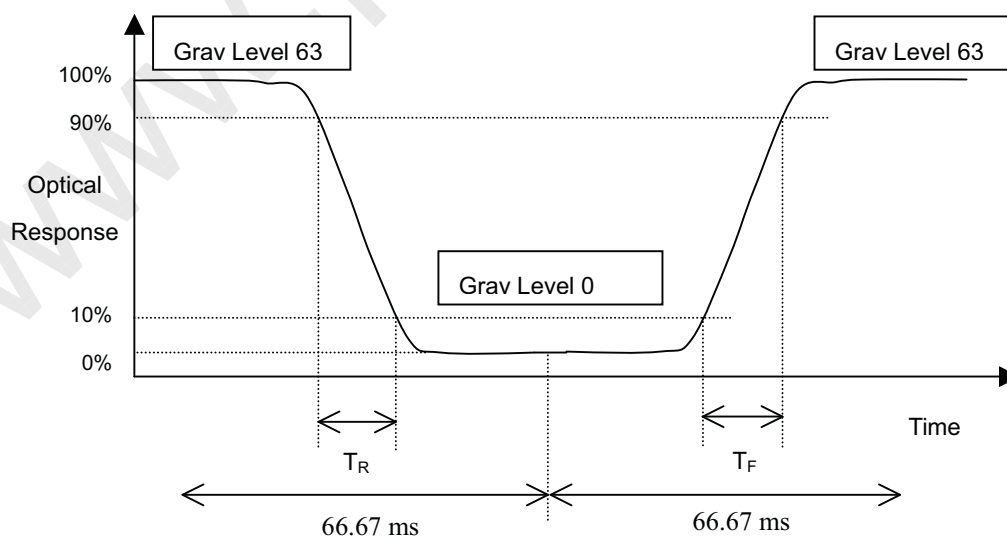

Note (4) Definition of Average Luminance of White (L_{AVE}):

Measure the luminance of gray level 63 at 5 points

$$L_{AVE} = [L(1) + L(2) + L(3) + L(4) + L(5)] / 5$$

$L(x)$ is corresponding to the luminance of the point X at Figure in Note (6).

Note (5) Measurement Setup:

The LCD module should be stabilized at given temperature for 15 minutes to avoid abrupt temperature change during measuring. In order to stabilize the luminance, the measurement should be executed after lighting Backlight for 15 minutes in a windless room.

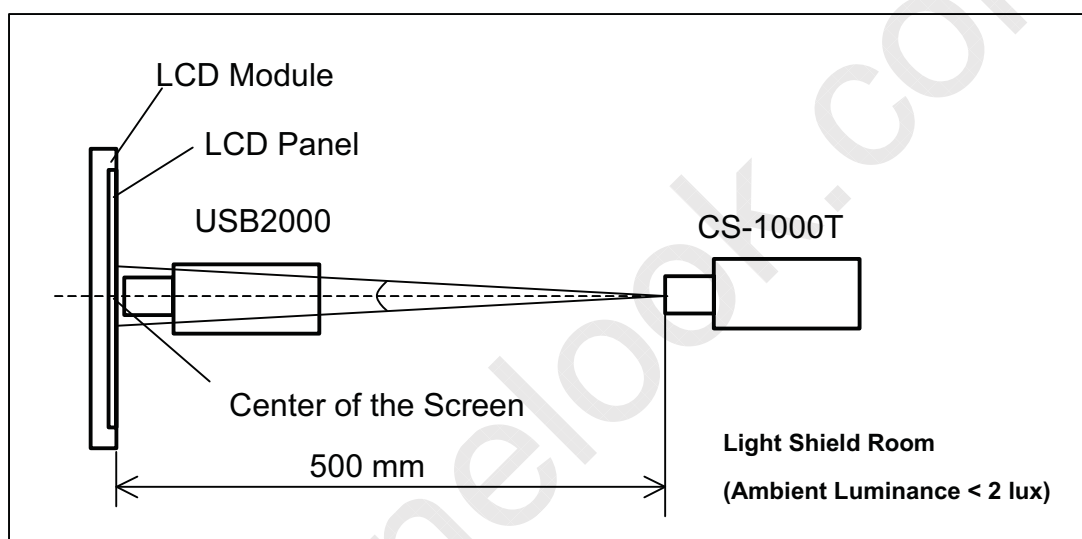

Note (6) Definition of White Variation (δW):

Measure the luminance of gray level 63 at 5 points

$$\delta W_{5p} = \text{Maximum} [L(1) \sim L(5)] / \text{Minimum} [L(1) \sim L(5)]$$

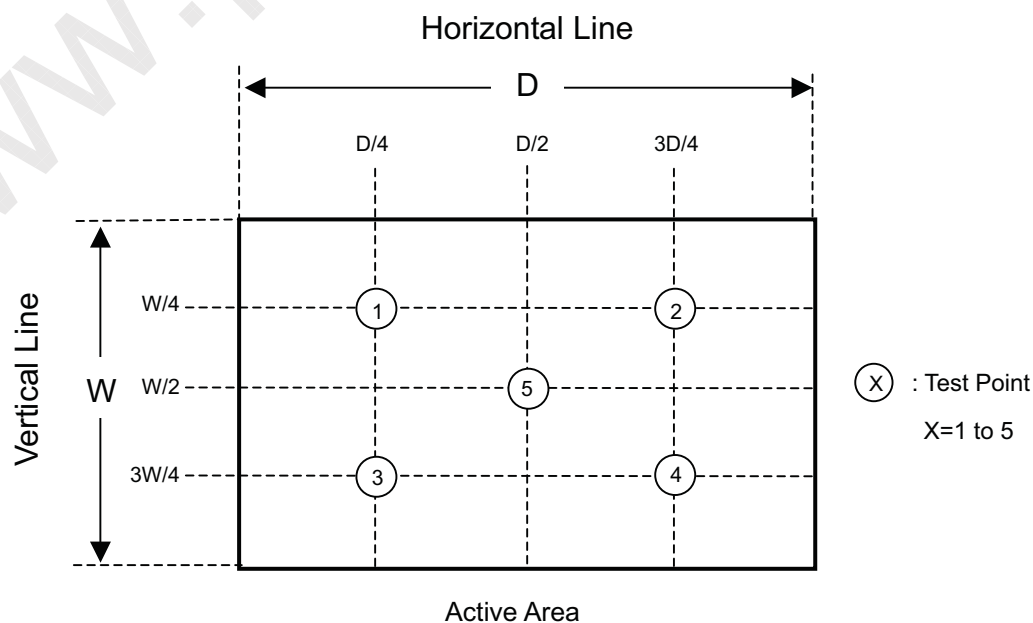

8. PRECAUTIONS

8.1 ASSEMBLY AND HANDLING PRECAUTIONS

- (1) Do not apply rough force such as bending or twisting to the module during assembly.
- (2) To assemble or install module into user's system can be only in clean working areas. The dust and oil may cause electrical short or worsen the polarizer.
- (3) It's not permitted to have pressure or impulse on the module because the LCD panel and Backlight will be damaged.
- (4) Always follow the correct power sequence when LCD module is connecting and operating. This can prevent damage to the CMOS LSI chips during latch-up.
- (5) Do not pull the I/F connector in or out while the module is operating.
- (6) Do not disassemble the module.
- (7) Use a soft dry cloth without chemicals for cleaning, because the surface of polarizer is very soft and easily scratched.
- (8) It is dangerous that moisture come into or contacted the LCD module, because moisture may damage LCD module when it is operating.
- (9) High temperature or humidity may reduce the performance of module. Please store LCD module within the specified storage conditions.
- (10) When ambient temperature is lower than 10°C may reduce the display quality. For example, the response time will become slowly, and the starting voltage of CCFL will be higher than room temperature.

8.2 SAFETY PRECAUTIONS

- (1) The startup voltage of Backlight is approximately 1000 Volts. It may cause electrical shock while assembling with inverter. Do not disassemble the module or insert anything into the Backlight unit.
- (2) If the liquid crystal material leaks from the panel, it should be kept away from the eyes or mouth. In case of contact with hands, skin or clothes, it has to be washed away thoroughly with soap.
- (3) After the module's end of life, it is not harmful in case of normal operation and storage.

9. PACKING

9.1 CARTON

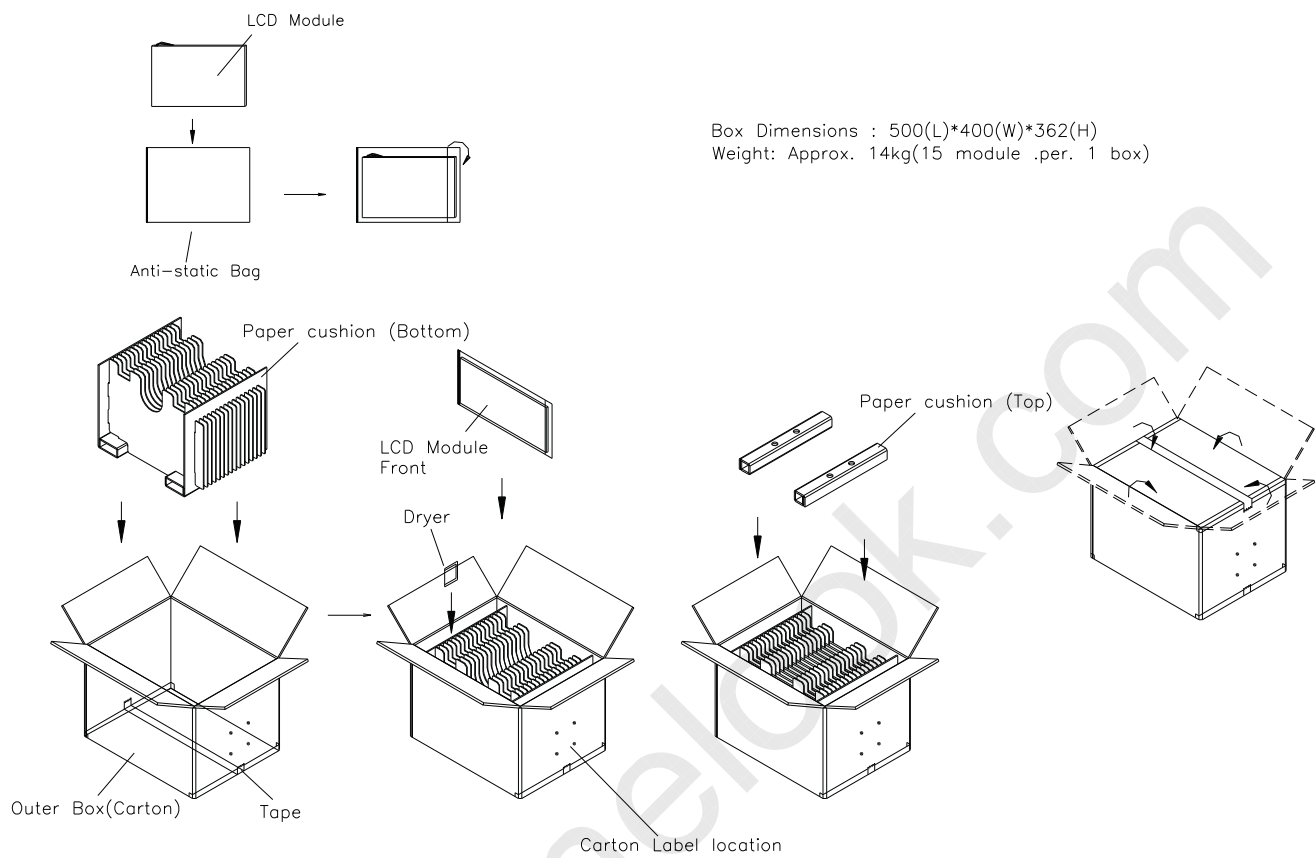

Figure. 9-1 Packing method

9.2 PALLET FOR SEA FREIGHT

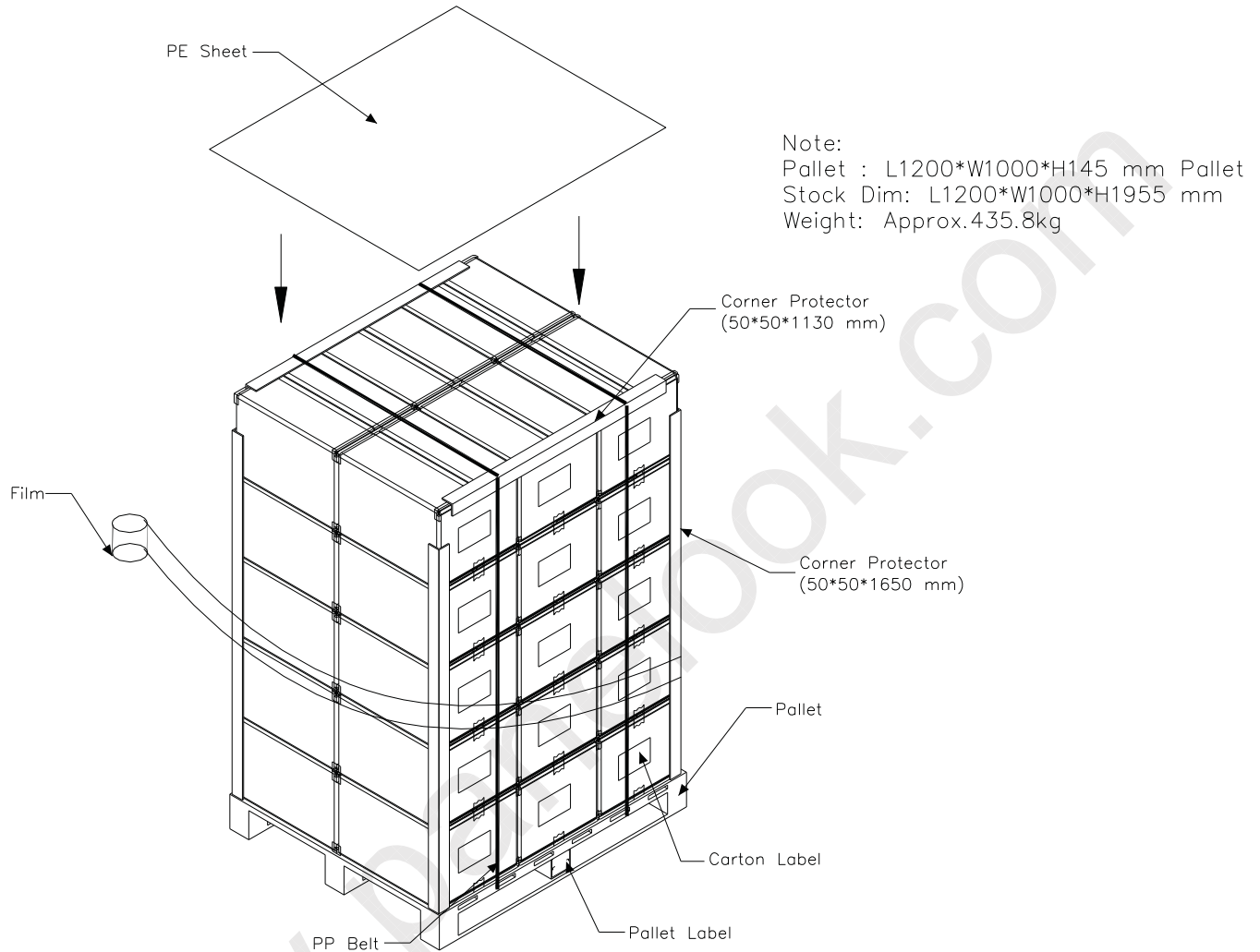

Figure. 9-2 Packing method

9.3 PALLET FOR AIR FREIGHT

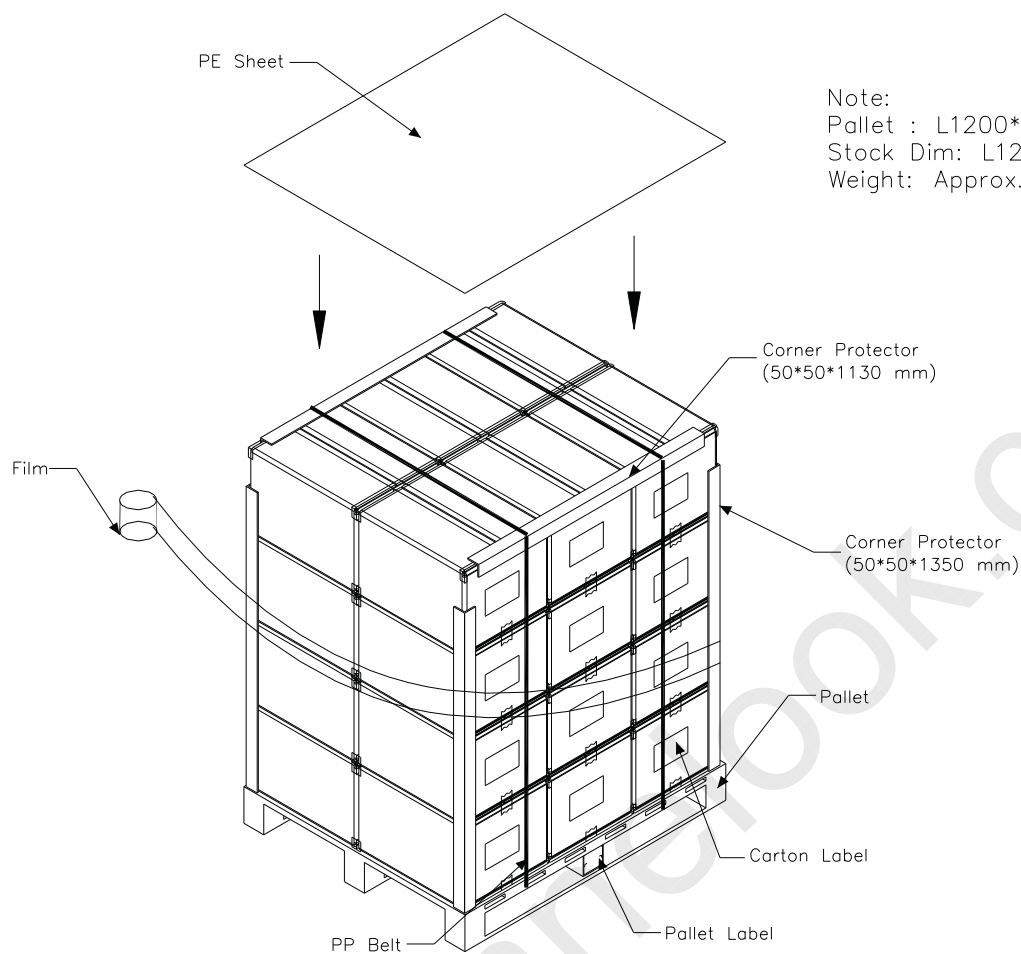
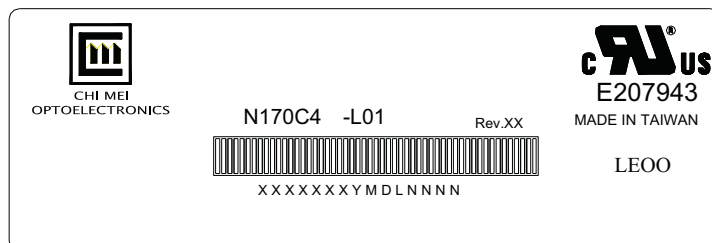

Figure. 9-3 Packing method

10. DEFINITION OF LABELS

10.1 CMO MODULE LABEL

The barcode nameplate is pasted on each module as illustration, and its definitions are as following explanation.



- (a) Model Name: N170C4 - L01
 (b) Revision: Rev. XX, for example: A1, ..., C1, C2 ...etc.
 (c) Serial ID: XXXXXXYMDXNNNN

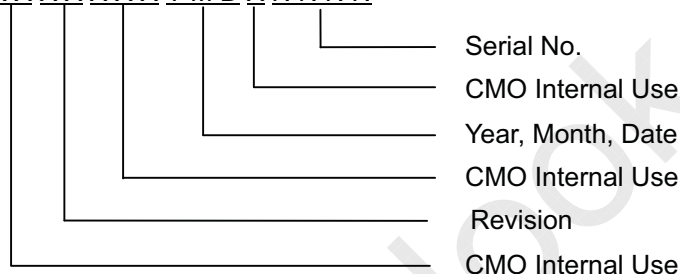

- (d) Production Location: MADE IN XXXX. XXXX stands for production location.
 (e) UL logo: LEOO especially stands for panel manufactured by CMO NingBo satisfying UL requirement.
 The panel without LEOO mark stands for manufactured by CMO Taiwan satisfying UL requirement.

Serial ID includes the information as below:

- (a) Manufactured Date: Year: 1~9, for 2001~2009
 Month: 1~9, A~C, for Jan. ~ Dec.
 Day: 1~9, A~Y, for 1st to 31st, exclude I, O and U
 (b) Revision Code: cover all the change
 (c) Serial No.: Manufacturing sequence of product



Preliminary

10.2 CARTON LABEL

CHI MEI OPTOELECTRONICS

PO.NO. _____

Part ID. _____

Model Name _____

Carton ID. _____ Quantities _____

Made In Taiwan

GP

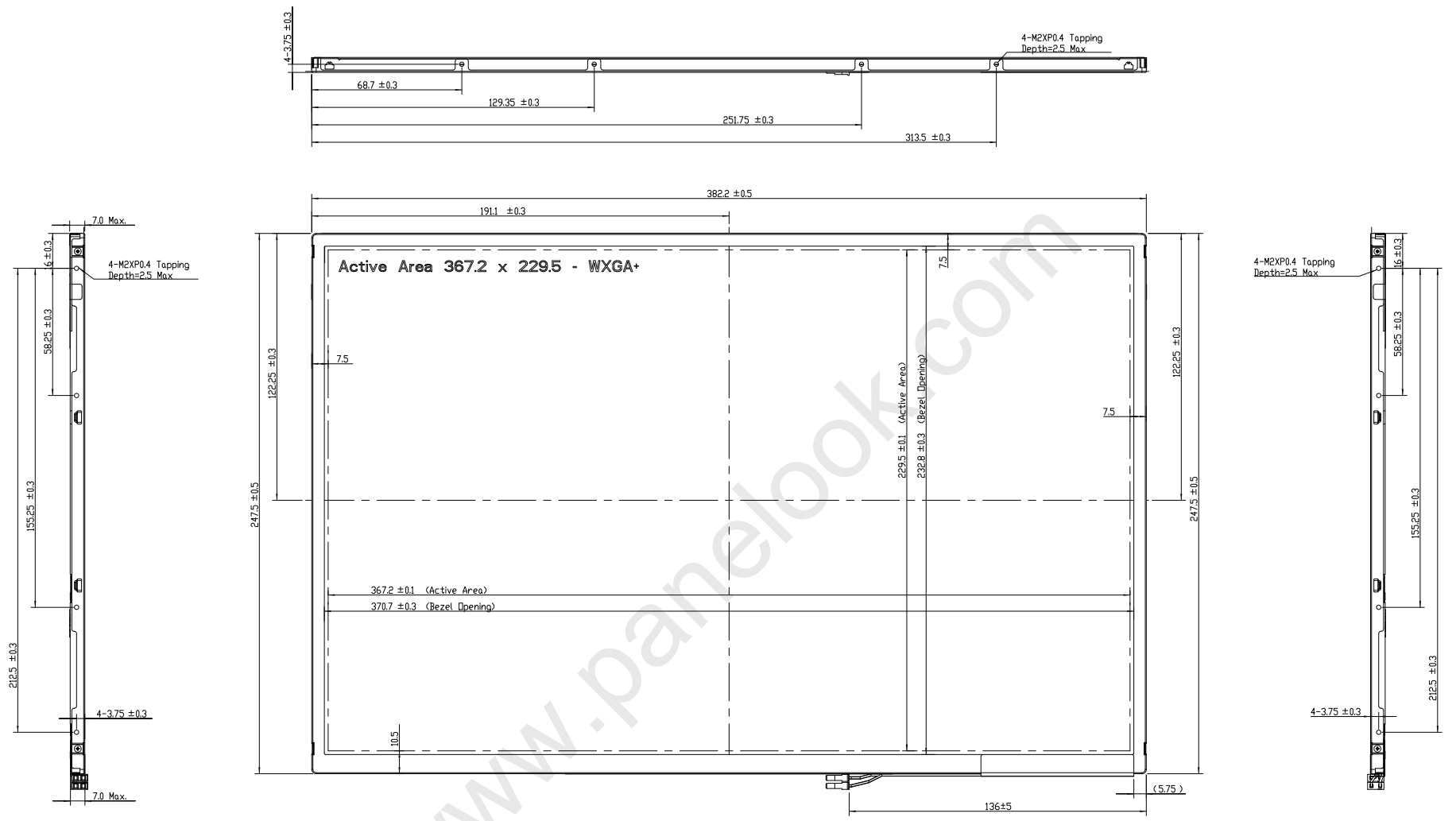

Notes:
 1.General Tolerance:±0.5mm.
 2.Screw Torque: Max 2.5 kgf-cm.
 3.Backlight Lamp Connector: BHSR-02VS-1 (JST).
 4.LCD Module Input Connector: FI-XB30SRL-HF11 (JAE).

Mark	Description	Date	Changed_By	Approved_By	ECN No.	Remark
1						
2						
3						
4						

TITLE Outline N170C4-L01/L02 Drawing				PD REV. 11
				SD REV. 11
Approved	Davis Wang	Drawing No.	N17044011	
Checked	Shannon	Part No.	NA	
Drawer	Kaljen Ke	Material	NA	Sheet 1 / 2 AI
Designer	Kaljen Ke	Date	18-Oct-2006	Scale 1:1 Uniten

CHI MEI OPTOELECTRONICS CORP. ALL RIGHTS RESERVED. COPYING FORBIDDEN.

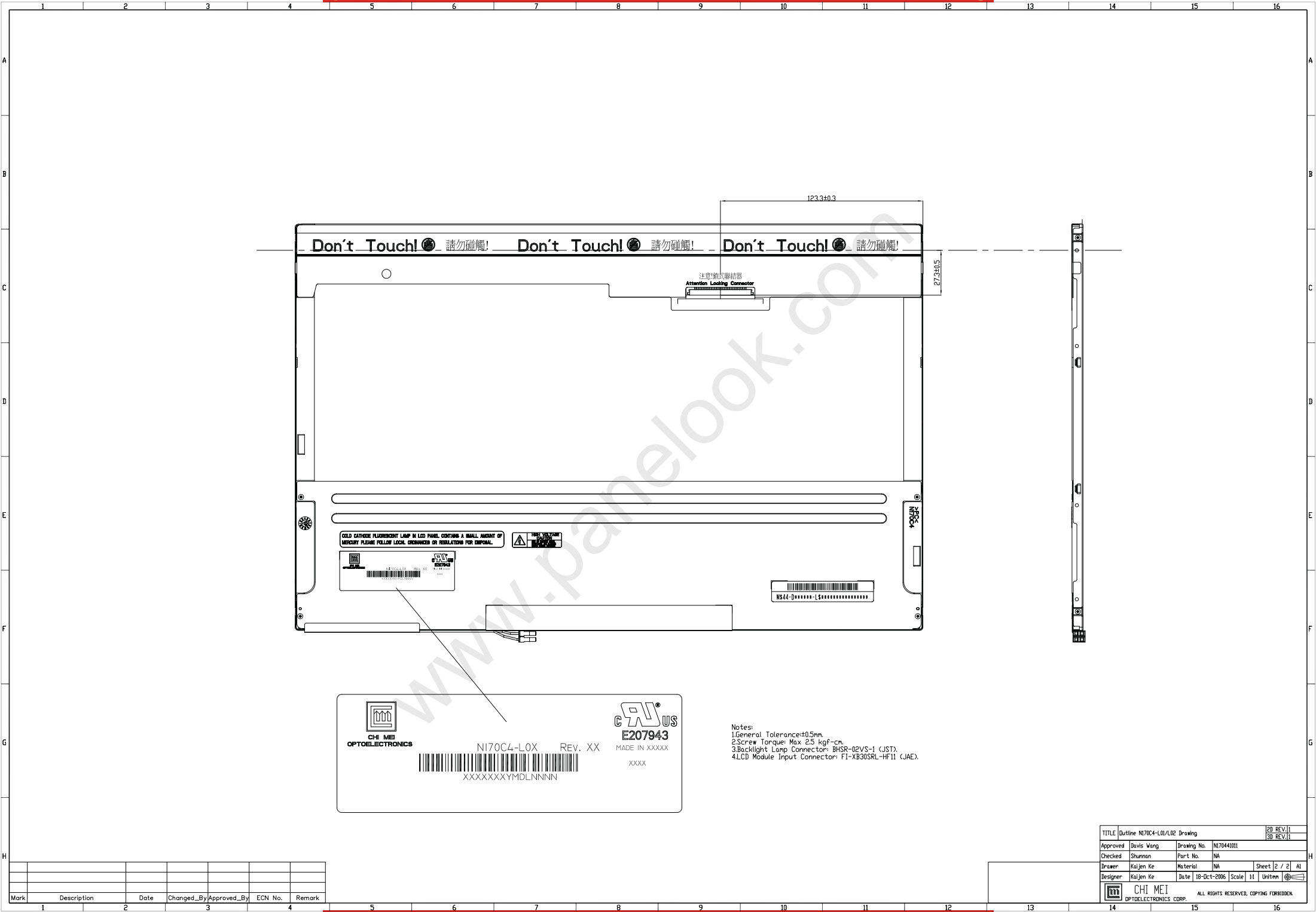

CHI MEI OPTOELECTRONICS

NI70C4-L0X REV. XX

CRV[®] E207943

MADE IN XXXXX

XXXXXXXYMDLNNNN

- Notes:
- 1.General Tolerance:±0.5mm.
 - 2.Screw Torque: Max 2.5 kgf·cm.
 - 3.Backlight Lamp Connector: BHSR-02VS-1 (JST).
 - 4.LCD Module Input Connector: FI-XB30SRL-HF11 (JAE).

Mark	Description	Date	Changed_By	Approved_By	ECN No.	Remark
1						
2						
3						
4						

TITLE Outline N70C4-L01/L02 Drawing						ED REV.1
						SD REV.1
Approved	Davis Wang	Drawing No.	N70441011			
Checked	Shannon	Part No.	NA			
Drawer	Kaijen Ke	Material	NA	Sheet	2 / 2	Alt
Designer	Kaijen Ke	Date	18-Oct-2006	Scale	1:1	Unit:mm

CHI MEI OPTOELECTRONICS CORP. ALL RIGHTS RESERVED. COPYING FORBIDDEN.