

**Doc. Number:**

- Tentative Specification  
 Preliminary Specification  
 Approval Specification

**MODEL NO.: N17306**  
**SUFFIX: P02**

**Customer:**
**APPROVED BY**
**SIGNATURE**
Name / Title

Note

Please return 1 copy for your confirmation with your signature and comments.

Approved By	Checked By	Prepared By
楊竣傑	曹文彬	吳彥儀
2012-01-12 16:09:59 CST	2012-01-12 11:28:36 CST	2012-01-04 13:03:42 CST

## CONTENTS

<b>1. GENERAL DESCRIPTION .....</b>	<b>4</b>
1.1 OVERVIEW .....	4
1.2 GENERAL SPECIFICATIONS .....	4
<b>2. MECHANICAL SPECIFICATIONS .....</b>	<b>4</b>
2.1 CONNECTOR TYPE .....	4
<b>3. ABSOLUTE MAXIMUM RATINGS .....</b>	<b>錯誤! 尚未定義書籤。</b>
3.1 ABSOLUTE RATINGS OF ENVIRONMENT (Based on CMI Module) .....	錯誤! 尚未定義書籤。
3.2 ABSOLUTE RATINGS OF ENVIRONMENT (OPEN CELL) .....	錯誤! 尚未定義書籤。
3.3 ELECTRICAL ABSOLUTE RATINGS (OPEN CELL) .....	錯誤! 尚未定義書籤。
3.3.1 TFT LCD MODULE .....	錯誤! 尚未定義書籤。
<b>4. ELECTRICAL SPECIFICATIONS .....</b>	<b>錯誤! 尚未定義書籤。</b>
4.1 TFT LCD OPEN CELL .....	錯誤! 尚未定義書籤。
4.2. INTERFACE CONNECTIONS .....	錯誤! 尚未定義書籤。
4.3 ELECTRICAL CHARACTERISTICS .....	錯誤! 尚未定義書籤。
4.3.1 TFT LCD OPEN CELL .....	錯誤! 尚未定義書籤。
4.3.2 LED CONVERTER SPECIFICATION .....	錯誤! 尚未定義書籤。
4.4 LVDS INPUT SIGNAL TIMING SPECIFICATIONS .....	155
4.4.1 LVDS DC SPECIFICATIONS .....	錯誤! 尚未定義書籤。
4.4.2 LVDS DATA FORMAT .....	錯誤! 尚未定義書籤。
4.4.3 COLOR DATA INPUT ASSIGNMENT .....	錯誤! 尚未定義書籤。
4.5 DISPLAY TIMING SPECIFICATIONS .....	177
4.6 POWER ON/OFF SEQUENCE .....	188
<b>5. OPTICAL CHARACTERISTICS .....</b>	<b>錯誤! 尚未定義書籤。</b>
5.1 TEST CONDITIONS .....	錯誤! 尚未定義書籤。
5.2 OPTICAL SPECIFICATIONS .....	錯誤! 尚未定義書籤。
<b>6. PACKING .....</b>	<b>錯誤! 尚未定義書籤。</b>
6.1 CMI OPEN CELL LABEL .....	錯誤! 尚未定義書籤。 2
6.2 Package Reliability .....	錯誤! 尚未定義書籤。 3
6.3 CARTON .....	錯誤! 尚未定義書籤。 3
6.4 PALLET .....	錯誤! 尚未定義書籤。 4
<b>7. PRECAUTIONS .....</b>	<b>255</b>
7.1 HANDLING PRECAUTIONS .....	255
7.2 STORAGE PRECAUTIONS .....	255
7.3 OPERATION PRECAUTIONS .....	255
Appendix. OUTLINE DRAWING .....	錯誤! 尚未定義書籤。 6

## REVISION HISTORY

Version	Date	Page	Description
2.0	22.Dec, 2011	All	Approval spec Ver.2.0 was first issued.

## 1. GENERAL DESCRIPTION

### 1.1 OVERVIEW

N17306 - P02 is a 17.3" TFT Liquid Crystal Display module with LED Backlight unit and 40 pins LVDS interface. This module supports 1600 x 900 HD+ mode and can display 262,144 colors. The backlight unit is not built in.

### 1.2 GENERAL SPECIFICATIONS

Item	Specification	Unit	Note
Screen Size	17.3 diagonal		
Driver Element	a-si TFT active matrix	-	-
Pixel Number	1600 x R.G.B. x 900	pixel	-
Pixel Pitch	0.2388 (H) x 0.2388(V)	mm	-
Pixel Arrangement	RGB vertical stripe	-	-
Display Colors	262,144	color	-
Transmissive Mode	Normally white	-	-
Surface Treatment	Hard coating (3H), Glare Type	-	-

## 2. MECHANICAL SPECIFICATIONS

item		Min.	Typ.	Max.	Unit	Note
Size	Horizontal (H) with PCB	390.84	391.34	391.84	mm	(1) (2)
	Horizontal (H) w/o PCB	390.84	391.34	391.84	mm	
	Vertical (V) with PCB	275.05	276.05	277.05	mm	
	Vertical (V) w/o PCB	221.7	222.20	222.70	mm	
	Thickness (T) with PCB	-	1.5		mm	
	Thickness (T) w/o PCB	-	1.27		mm	
Weight		-	261	266	g	
I/F connector mounting position		The mounting inclination of the connector makes the screen center within $\pm 0.5$ mm as the horizontal.				

Note (1) Please refer to the attached drawings for more information of front and back outline dimensions.

(2) Connector mounting position

### 2.1 CONNECTOR TYPE

#### 2.1.1 LVDS Connector

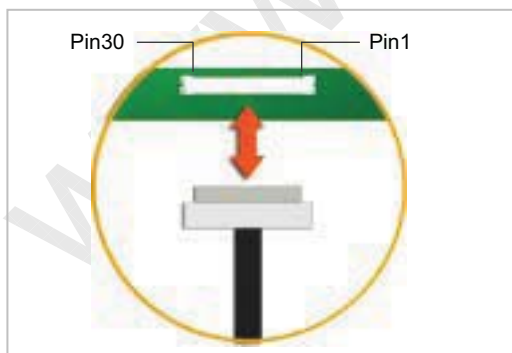

Please refer Appendix Outline Drawing for detail design.  
 Connector Part No.: IPEX-20455-040E-12 or equivalent  
 User's connector Part No.: IPEX-20453-040T-01 or equivalent

**2.1.2 LED Light-Bar Connector**

Connector Part No :FCI-59453-121110EDHLF



www.panelook.com

### 3. ABSOLUTE MAXIMUM RATINGS

#### 3.1 ABSOLUTE RATINGS OF ENVIRONMENT (Based on CMI Module)

Item	Symbol	Value		Unit	Note
		Min.	Max.		
Storage Temperature	T <sub>ST</sub>	-20	+60	°C	(1)
Operating Ambient Temperature	T <sub>OP</sub>	0	+50	°C	(1), (2)

Note (1) (a) 90 %RH Max. (Ta ≤ 40 °C).

(b) Wet-bulb temperature should be 39 °C Max. (Ta > 40 °C).

(c) No condensation.

Note (2) The temperature of panel surface should be 0 °C min. and 60 °C max.

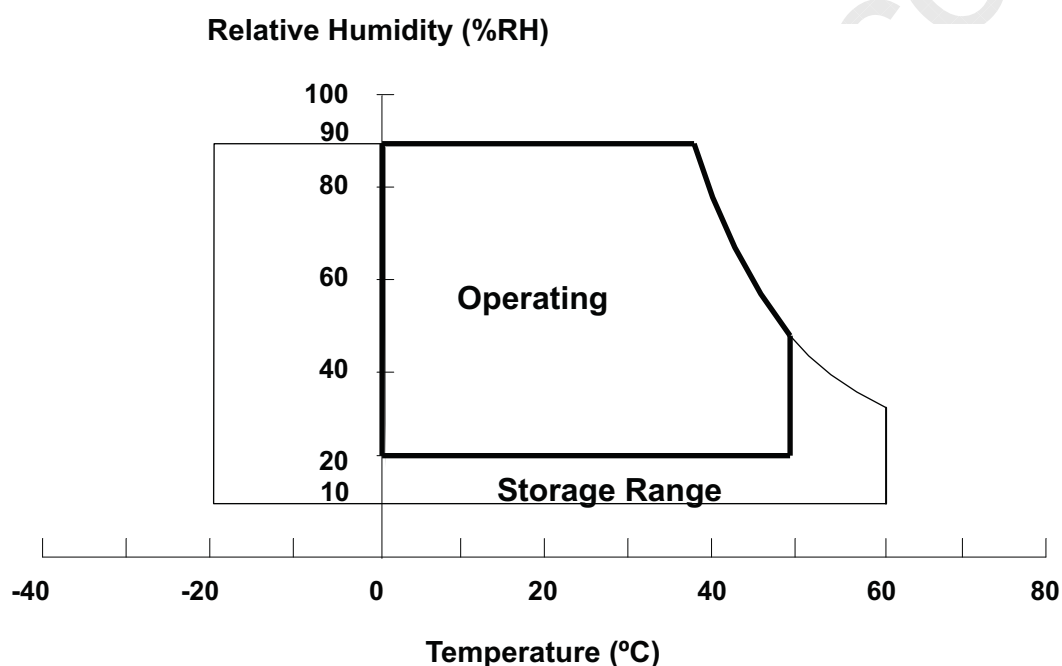

#### 3.2 ABSOLUTE RATINGS OF ENVIRONMENT (OPEN CELL)

High temperature or humidity may reduce the performance of panel. Please store LCD panel within the specified storage conditions.

Storage Condition: With packing.

Storage temperature range: 25±5 °C.

Storage humidity range: 50±10%RH.

Shelf life: 30days

## 3.3 ELECTRICAL ABSOLUTE RATINGS (OPEN CELL)

### 3.3.1 TFT LCD MODULE

Item	Symbol	Value		Unit	Note
		Min.	Max.		
Power Supply Voltage	VCCS	-0.3	+4.0	V	(1)
Logic Input Voltage	V <sub>IN</sub>	-0.3	VCCS+0.3	V	

Note (1) Stresses beyond those listed in above "ELECTRICAL ABSOLUTE RATINGS" may cause permanent damage to the device. Normal operation should be restricted to the conditions described in "ELECTRICAL CHARACTERISTICS".

## 4. ELECTRICAL SPECIFICATIONS

### 4.1 TFT LCD OPEN CELL

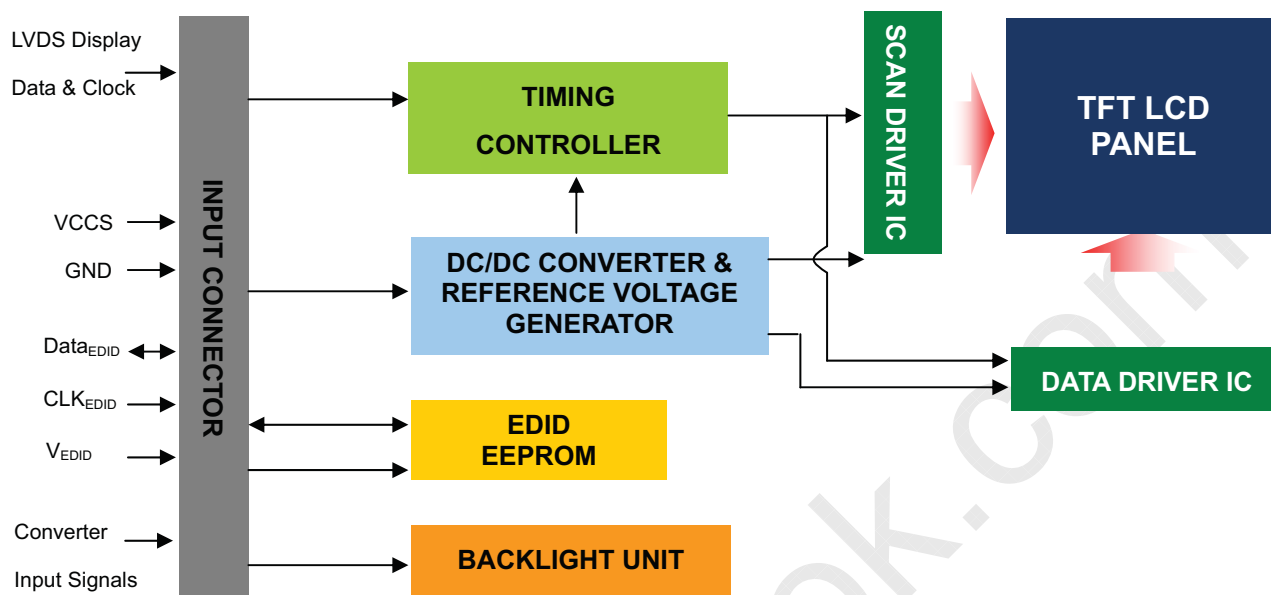

## 4.2. INTERFACE CONNECTIONS

### 4.2.1 PIN ASSIGNMENT

Pin	Symbol	Description	Remark
1	NC	Loop or No Connection	
2	VCCS	Power Supply (3.3V typ.)	
3	VCCS	Power Supply (3.3V typ.)	
4	VEDID	DDC 3.3V power	
5	BIST	Panel self test	
6	CLKEDID	DDC clock	
7	DATAEDID	DDC data	
8	RX00-	LVDS Differential Data Input (Odd)	R0-R5, G0
9	RX00+	LVDS Differential Data Input (Odd)	
10	VSS	Ground	
11	RX01-	LVDS Differential Data Input (Odd)	G1~G5, B0, B1
12	RX01+	LVDS Differential Data Input (Odd)	
13	VSS	Ground	
14	RX02-	LVDS Differential Data Input (Odd)	B2-B5, HS, VS, DE
15	RX02+	LVDS Differential Data Input (Odd)	
16	VSS	Ground	
17	RXOC-	LVDS Clock Data Input (Odd)	LVDS CLK
18	RXOC+	LVDS Clock Data Input (Odd)	
19	VSS	Ground	
20	RXE0-	LVDS Differential Data Input (Even)	R0-R5, G0
21	RXE0+	LVDS Differential Data Input (Even)	
22	VSS	Ground	
23	RXE1-	LVDS Differential Data Input (Even)	G1~G5, B0, B1



24	RXE1+	LVDS Differential Data Input (Even)	
25	VSS	Ground	
26	RXE2-	LVDS Differential Data Input (Even)	B2-B5,HS,VS, DE
27	RXE2+	LVDS Differential Data Input (Even)	
28	VSS	Ground	
29	RXEC-	LVDS Clock Data Input (Even)	LVDS CLK
30	RXEC+	LVDS Clock Data Input (Even)	
31	LED_GND	LED Ground	
32	LED_GND	LED Ground	
33	LED_GND	LED Ground	
34	NC	Loop or No Connection	
35	LED_PWM	PWM Control Signal of LED Converter	
36	LED_EN	Enable Control Signal of LED Converter	
37	NC	No Connection (Reserve)	
38	LED_VCCS	LED Power Supply	
39	LED_VCCS	LED Power Supply	
40	LED_VCCS	LED Power Supply	

Note (1) The first pixel is odd as shown in the following figure.

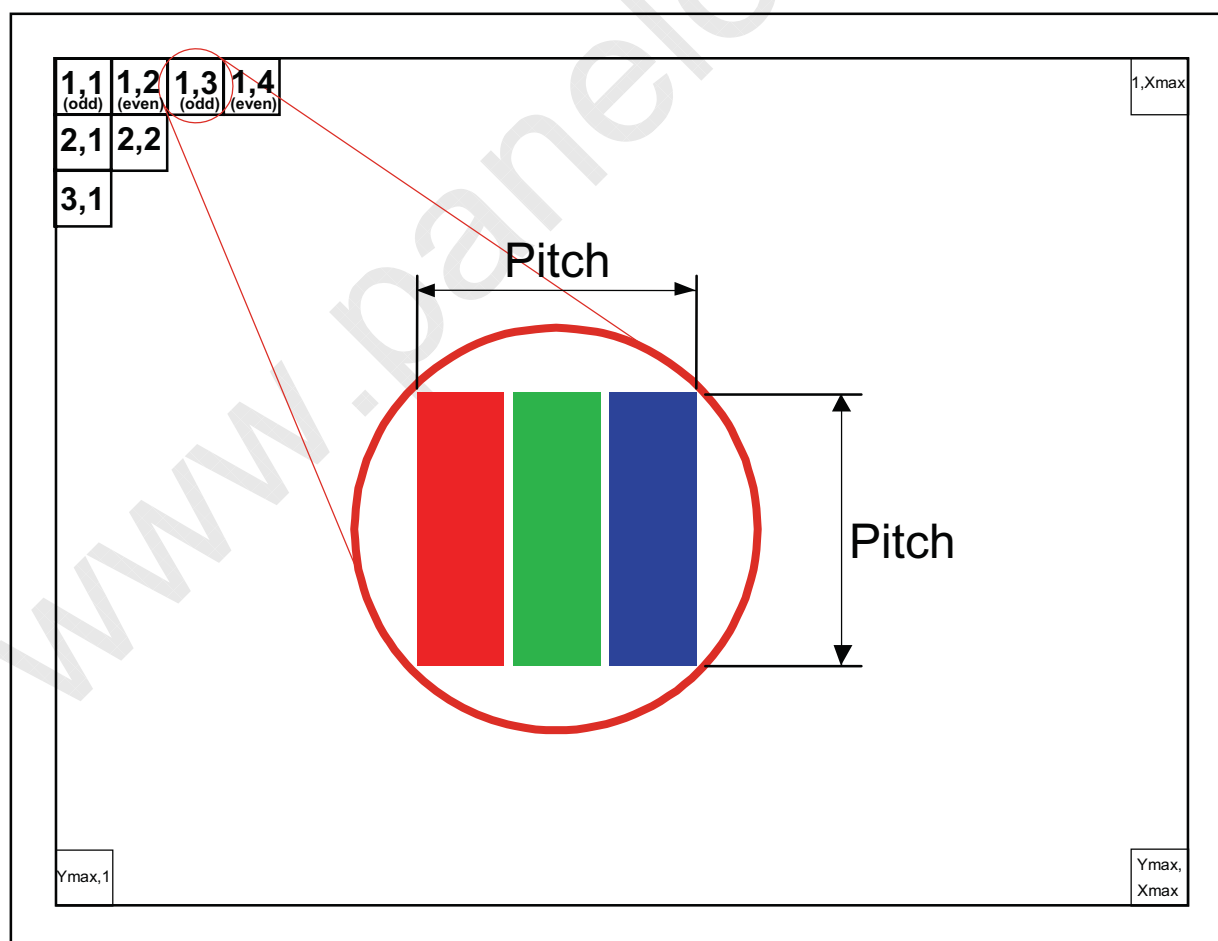

**4.2.2 LED CONVERTER OUTPUT PIN ASSIGNMENT**

Pin	Symbol	Description	Remark
1	NC	No connection	
2	CH7	Light-bar Feedback Channel 7	
3	CH6	Light-bar Feedback Channel 6	
4	CH5	Light-bar Feedback Channel 5	
5	CH4	Light-bar Feedback Channel 4	
6	CH3	Light-bar Feedback Channel 3	
7	CH2	Light-bar Feedback Channel 2	
8	CH1	Light-bar Feedback Channel 1	
9	NC	No connection	
10	LED_VCC	LED Light-bar Input Power	
11	LED_VCC	LED Light-bar Input Power	
12	LED_VCC	LED Light-bar Input Power	

www.panelook.com

### 4.3 ELECTRICAL CHARACTERISTICS

#### 4.3.1 TFT LCD OPEN CELL

Parameter	Symbol	Value			Unit	Note
		Min.	Typ.	Max.		
Power Supply Voltage	VCCS	3.0	3.3	3.6	V	(1)-
Ripple Voltage	V <sub>RP</sub>	-	50	-	mV	(1)-
Inrush Current	I <sub>RUSH</sub>	-	-	1.5	A	(1),(2)
Power Supply Current	Mosaic	270	320	370	mA	(3)a
	Black	320	350	390	mA	(3)b

Note (1) The ambient temperature is  $T_a = 25 \pm 2 \text{ }^\circ\text{C}$ .

Note (2) I<sub>RUSH</sub>: the maximum current when VCCS is rising

I<sub>IS</sub>: the maximum current of the first 100ms after power-on

Measurement Conditions: Shown as the following figure. Test pattern: black.

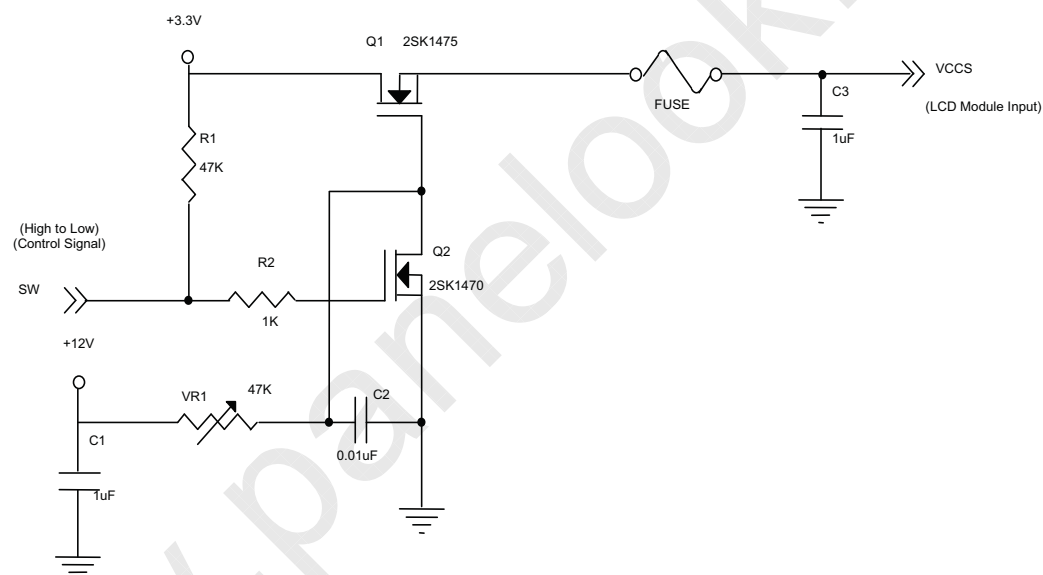

**VCCS rising time is 0.5ms**

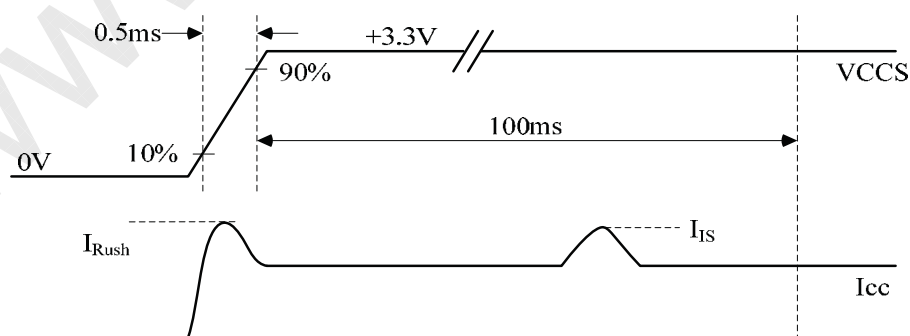

Note (3) The specified power supply current is under the conditions at  $V_{CCS} = 3.3\text{ V}$ ,  $T_a = 25 \pm 2\text{ }^\circ\text{C}$ , DC Current and  $f_v = 60\text{ Hz}$ , whereas a power dissipation check pattern below is displayed.

a. Mosaic Pattern

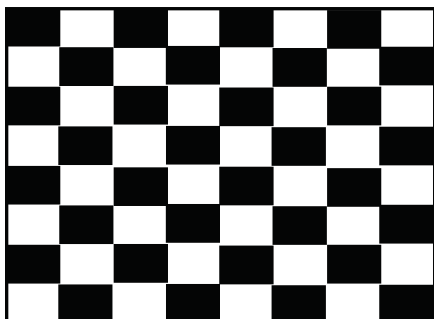

Active Area

b. Black Pattern



Active Area

www.panelook.com

## 4.3.2 LED CONVERTER SPECIFICATION

Parameter		Symbol	Value			Unit	Note
			Min.	Typ.	Max.		
Converter Input power supply voltage		LED_Vccs	7.5	12.0	21.0	V	
Converter Inrush Current		I <sub>LED_RUSH</sub>	-	-	1.5	A	(1)
EN Control Level	Backlight On		2	-	5	V	
	Backlight Off		0	-	0.8	V	
PWM Control Level	PWM High Level		2	-	5	V	
	PWM Low Level		0	-	0.15	V	
PWM Control Duty Ratio			10	-	100	%	
			5	-	100	%	(2)
PWM Control Permissible Ripple Voltage		V <sub>PWM_pp</sub>	-	-	100	mV	
PWM Control Frequency		f <sub>PWM</sub>	190	-	1K	Hz	(3)
LED Power Current	LED_VCCS =Typ.	I <sub>LED</sub>	260	331	393	mA	(4)

Note (1) I<sub>LED\_RUSH</sub>: the maximum current when LED\_VCCS is rising,

I<sub>LED\_IS</sub>: the maximum current of the first 100ms after power-on,

Measurement Conditions: Shown as the following figure. LED\_VCCS = Typ, Ta = 25 ± 2 °C, f<sub>PWM</sub> = 200 Hz, Duty=100%.

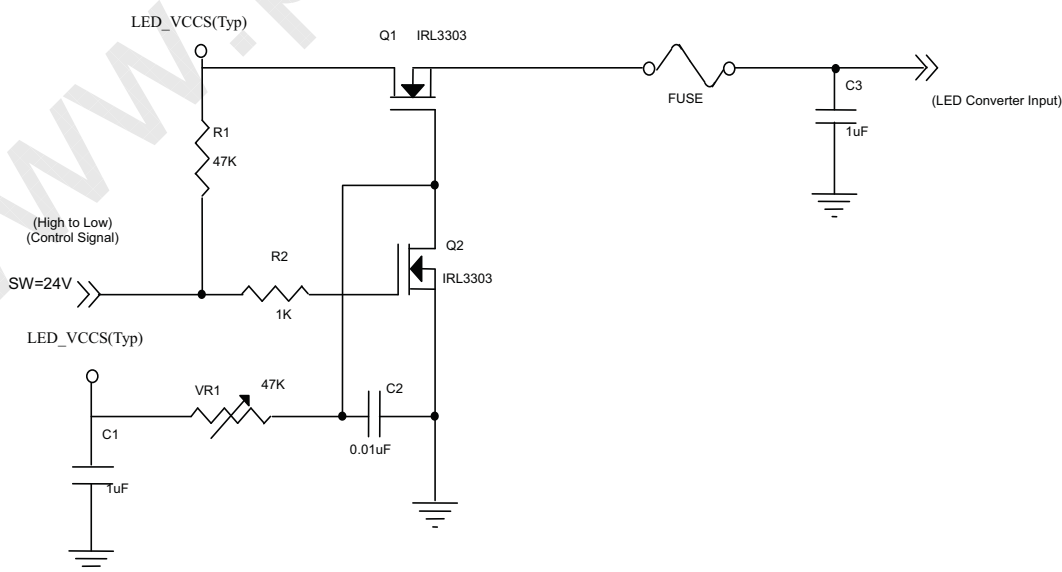

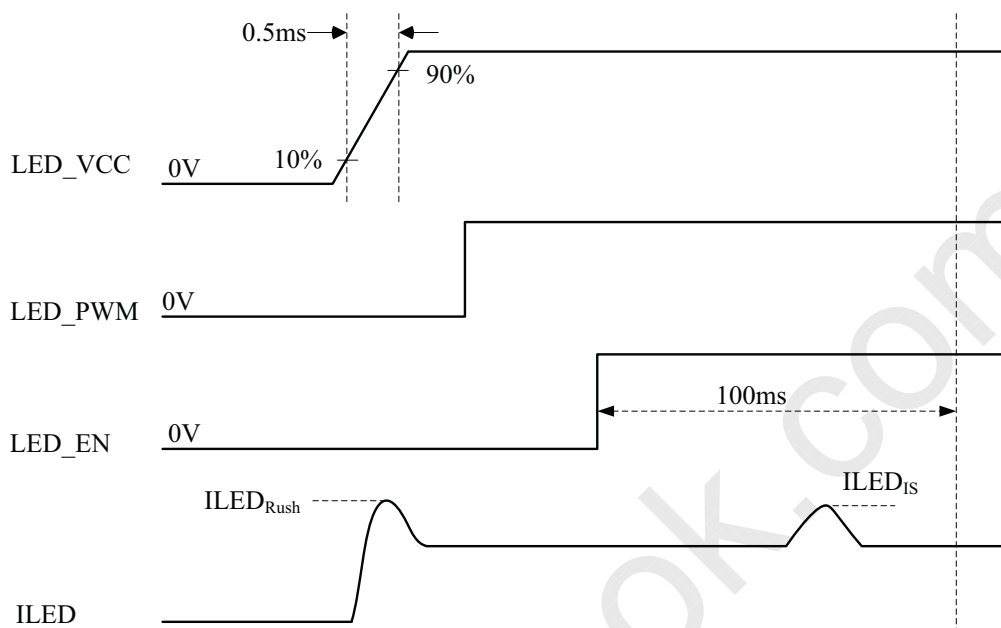
**VLED rising time is 0.5ms**

Note (2) If the PWM control duty ratio is less than 10%, there is some possibility that acoustic noise or backlight flash can be found. And it is also difficult to control the brightness linearity.

Note (3) If PWM control frequency is applied in the range less than 1KHz, the “waterfall” phenomenon on the screen may be found. To avoid the issue, it’s a suggestion that PWM control frequency should follow the criterion as below.

PWM control frequency  $f_{PWM}$  should be in the range

$$(N + 0.33) * f \leq f_{PWM} \leq (N + 0.66) * f$$

$N$  : Integer ( $N \geq 3$ )

$f$  : Frame rate

Note (4) The specified LED power supply current is under the conditions at “LED\_VCCS = Typ.”,  $T_a = 25 \pm 2 \text{ }^\circ\text{C}$ ,  $f_{PWM} = 200 \text{ Hz}$ , Duty=100%.

## 4.4 LVDS INPUT SIGNAL TIMING SPECIFICATIONS

### 4.4.1 LVDS DC SPECIFICATIONS

Parameter	Symbol	Value			Unit	Note
		Min.	Typ.	Max.		
LVDS Differential Input High Threshold	$V_{TH(LVDS)}$	-	-	+100	mV	(1), $V_{CM}=1.2V$
LVDS Differential Input Low Threshold	$V_{TL(LVDS)}$	-100	-	-	mV	(1), $V_{CM}=1.2V$
LVDS Common Mode Voltage	$V_{CM}$	1.125	-	1.375	V	(1)
LVDS Differential Input Voltage	$ V_{ID} $	100	-	600	mV	(1)
LVDS Terminating Resistor	$R_T$	-	100	-	Ohm	-

Note (1) The parameters of LVDS signals are defined as the following figures.

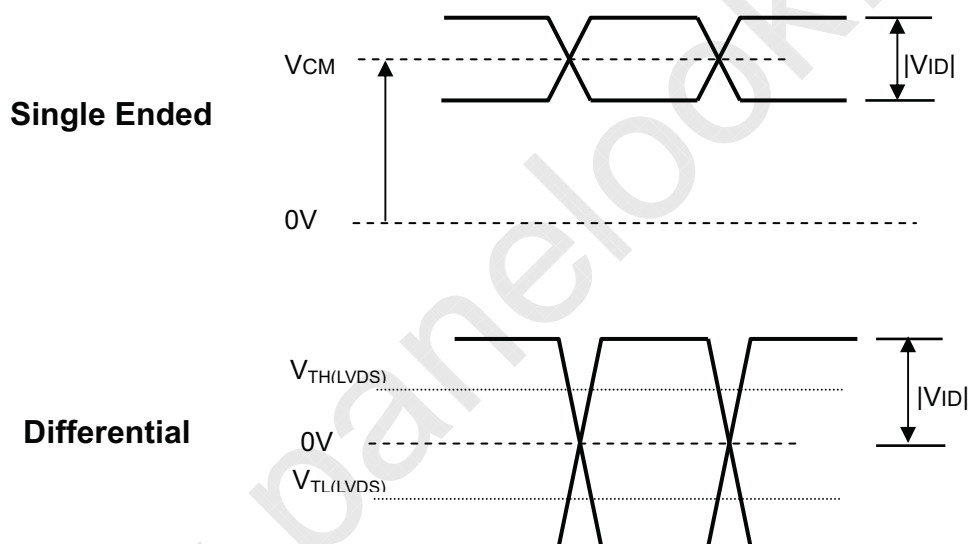

### 4.4.2 LVDS DATA FORMAT

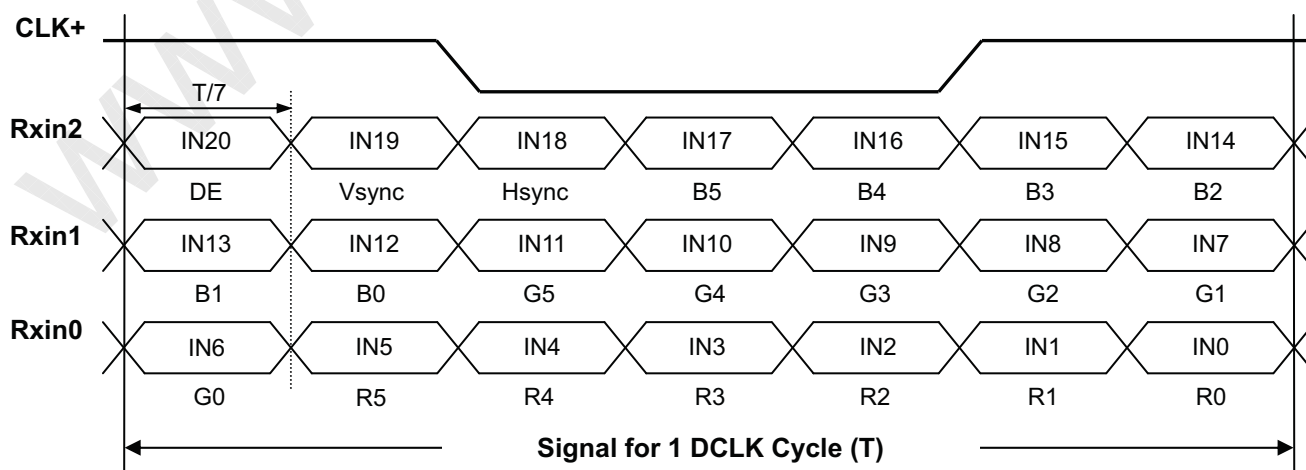

## 4.4.3 COLOR DATA INPUT ASSIGNMENT

The brightness of each primary color (red, green and blue) is based on the 6-bit gray scale data input for the color. The higher the binary input the brighter the color. The table below provides the assignment of color versus data input.

Color		Data Signal																	
		Red						Green						Blue					
		R5	R4	R3	R2	R1	R0	G5	G4	G3	G2	G1	G0	B5	B4	B3	B2	B1	B0
Basic Colors	Black	0	0	0	0	0	0	0	0	0	0	0	0	0	0	0	0	0	0
	Red	1	1	1	1	1	1	0	0	0	0	0	0	0	0	0	0	0	0
	Green	0	0	0	0	0	0	1	1	1	1	1	1	0	0	0	0	0	0
	Blue	0	0	0	0	0	0	0	0	0	0	0	0	1	1	1	1	1	1
	Cyan	0	0	0	0	0	0	1	1	1	1	1	1	1	1	1	1	1	1
	Magenta	1	1	1	1	1	1	0	0	0	0	0	0	1	1	1	1	1	1
	Yellow	1	1	1	1	1	1	1	1	1	1	1	1	0	0	0	0	0	0
	White	1	1	1	1	1	1	1	1	1	1	1	1	1	1	1	1	1	1
Gray Scale Of Red	Red(0)/Dark	0	0	0	0	0	0	0	0	0	0	0	0	0	0	0	0	0	0
	Red(1)	0	0	0	0	0	1	0	0	0	0	0	0	0	0	0	0	0	0
	Red(2)	0	0	0	0	1	0	0	0	0	0	0	0	0	0	0	0	0	0
	:	:	:	:	:	:	:	:	:	:	:	:	:	:	:	:	:	:	:
	:	:	:	:	:	:	:	:	:	:	:	:	:	:	:	:	:	:	:
	Red(61)	1	1	1	1	0	1	0	0	0	0	0	0	0	0	0	0	0	0
	Red(62)	1	1	1	1	1	0	0	0	0	0	0	0	0	0	0	0	0	0
	Red(63)	1	1	1	1	1	1	0	0	0	0	0	0	0	0	0	0	0	0
Gray Scale Of Green	Green(0)/Dark	0	0	0	0	0	0	0	0	0	0	0	0	0	0	0	0	0	0
	Green(1)	0	0	0	0	0	0	0	0	0	0	0	1	0	0	0	0	0	0
	Green(2)	0	0	0	0	0	0	0	0	0	0	1	0	0	0	0	0	0	0
	:	:	:	:	:	:	:	:	:	:	:	:	:	:	:	:	:	:	:
	:	:	:	:	:	:	:	:	:	:	:	:	:	:	:	:	:	:	:
	Green(61)	0	0	0	0	0	0	1	1	1	1	0	1	0	0	0	0	0	0
	Green(62)	0	0	0	0	0	0	1	1	1	1	1	0	0	0	0	0	0	0
	Green(63)	0	0	0	0	0	0	1	1	1	1	1	1	0	0	0	0	0	0
Gray Scale Of Blue	Blue(0)/Dark	0	0	0	0	0	0	0	0	0	0	0	0	0	0	0	0	0	0
	Blue(1)	0	0	0	0	0	0	0	0	0	0	0	0	0	0	0	0	0	1
	Blue(2)	0	0	0	0	0	0	0	0	0	0	0	0	0	0	0	0	1	0
	:	:	:	:	:	:	:	:	:	:	:	:	:	:	:	:	:	:	:
	:	:	:	:	:	:	:	:	:	:	:	:	:	:	:	:	:	:	:
	Blue(61)	0	0	0	0	0	0	0	0	0	0	0	0	1	1	1	1	0	1
	Blue(62)	0	0	0	0	0	0	0	0	0	0	0	0	1	1	1	1	1	0
	Blue(63)	0	0	0	0	0	0	0	0	0	0	0	0	1	1	1	1	1	1

Note (1) 0: Low Level Voltage, 1: High Level Voltage



#### 4.5 DISPLAY TIMING SPECIFICATIONS

The input signal timing specifications are shown as the following table and timing diagram.

Refresh rate 60Hz

Signal	Item	Symbol	Min.	Typ.	Max.	Unit	Note
DCLK	Frequency	1/Tc	44	48.9	51.4	MHz	-
DE	Vertical Total Time	TV	903	926	1157	TH	-
	Vertical Active Display Period	TVD	900	900	900	TH	-
	Vertical Active Blanking Period	TVB	TV-TVD	26	TV-TVD	TH	-
	Horizontal Total Time	TH	1682	1760	2200	Tc	-
	Horizontal Active Display Period	THD	1600	1600	1600	Tc	-
	Horizontal Active Blanking Period	THB	TH-THD	160	TH-THD	Tc	-

Note (1) Because this module is operated by DE only mode, Hsync and Vsync are ignored.

**INPUT SIGNAL TIMING DIAGRAM**

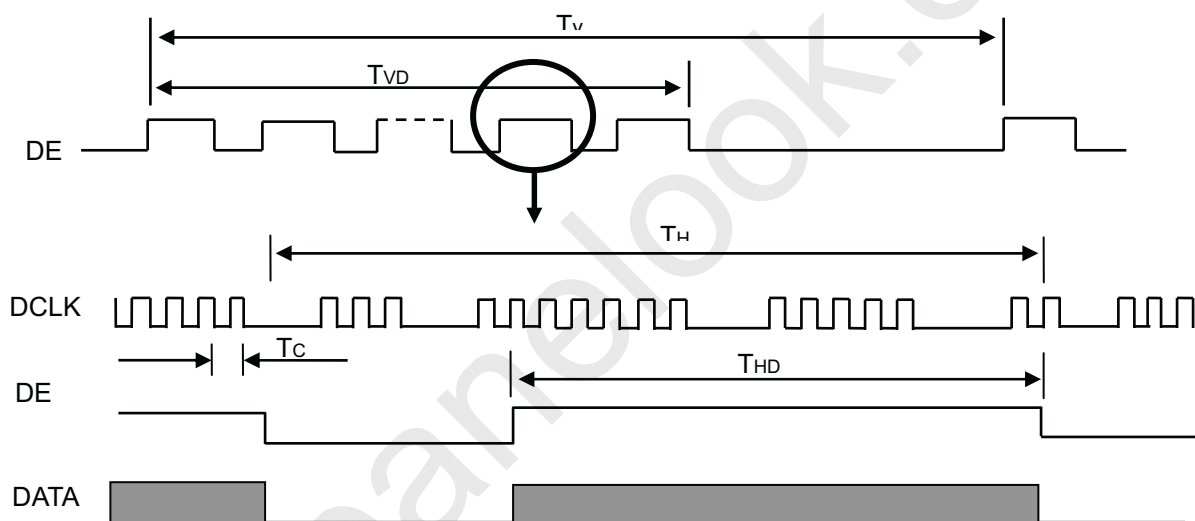

#### 4.6 POWER ON/OFF SEQUENCE

The power sequence specifications are shown as the following table and diagram.

Symbol	Value			Unit	Note
	Min.	Typ.	Max.		
t1	0.5	-	10	Ms	
t2	0	-	50	Ms	
t3	0	-	50	Ms	
t4	500	-	-	Ms	
t5	200	-	-	Ms	
t6	200	-	-	Ms	
t7	0.5	-	10	Ms	
t <sub>A</sub>	0.5	-	10	Ms	
t <sub>B</sub>	0	-	10	Ms	
t <sub>C</sub>	10	-	-	Ms	
t <sub>D</sub>	10	-	-	Ms	
t <sub>E</sub>	10	-	-	Ms	
t <sub>F</sub>	10	-	-	Ms	

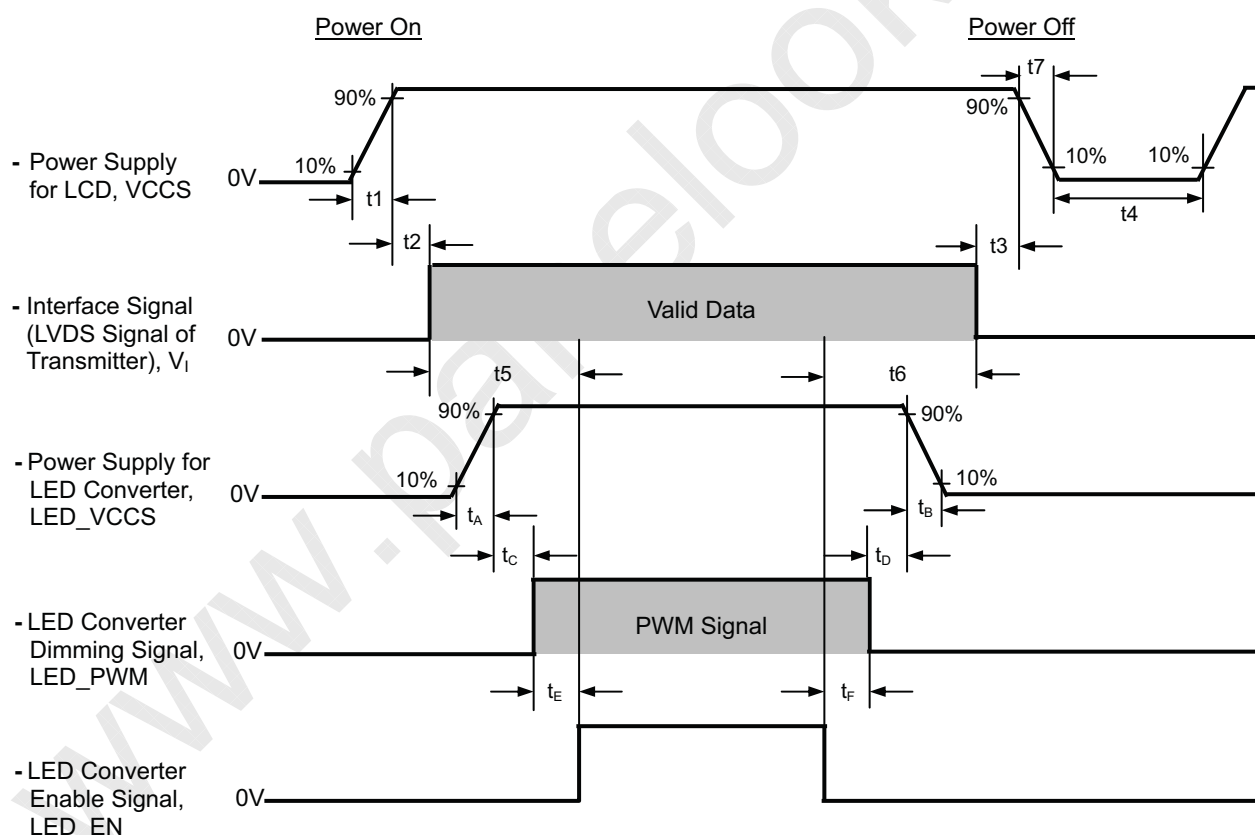

Note (1) Please don't plug or unplug the interface cable when system is turned on.

Note (2) Please avoid floating state of the interface signal during signal invalid period.

Note (3) It is recommended that the backlight power must be turned on after the power supply for LCD and the interface signal is valid.

## 5. OPTICAL CHARACTERISTICS

### 5.1 TEST CONDITIONS

Item	Symbol	Value	Unit
Ambient Temperature	Ta	25±2	°C
Ambient Humidity	Ha	50±10	%RH
Supply Voltage	V <sub>CC</sub>	3.3	V
Input Signal	According to typical value in "3. ELECTRICAL CHARACTERISTICS"		

The measurement methods of optical characteristics are shown in Section 5.2. The following items should be measured under the test conditions described in Section 5.1 and stable environment shown in Note (5).

### 5.2 OPTICAL SPECIFICATIONS

The relative measurement methods of optical characteristics are shown as below. The following items should be measured under the test conditions described in 5.1 and stable environment shown in Note (6).

Item	Symbol	Condition	Min.	Typ.	Max.	Unit	Note	
Color Chromaticity	Red	$\theta_x=0^\circ, \theta_y=0^\circ$ CS-2000T Standard light source "C"	Typ - 0.03	0.629	Typ + 0.03	-	(0),(6)	
				0.326		-		
	Green			0.282		-		
				0.563		-		
	Blue			0.157		-		
				0.108		-		
	White			0.307		-		
				0.323		-		
Center Transmittance	T%	$\theta_x=0^\circ, \theta_y=0^\circ$	5.61	6.6			(1), (8)	
Contrast Ratio	CR	CS-2000T, CMO BLU	500	650		-	(1), (3)	
Response Time	T <sub>R</sub>	$\theta_x=0^\circ, \theta_y=0^\circ$		2	8	ms	(4)	
	T <sub>F</sub>			6	12	ms		
Transmittance uniformity	$\delta T\%$	$\theta_x=0^\circ, \theta_y=0^\circ$ BM-5A		1.25	1.40	-	(1), (7)	
Viewing Angle	Horizontal	CR≥10 BM-5A		40	45		Deg.	(1), (3) (6)
				40	45			
	Vertical			15	20			
				40	45			

Note (0) Light source is the standard light source "C" which is defined by CIE and driving voltages are based on suitable gamma voltages. The calculating method is as following :

1. Measure Module's and BLU's spectrums. White is without signal input and R, G, B are with signal input. BLU is supplied by CMI.
2. Calculate cell's spectrum.
3. Calculate cell's chromaticity by using the spectrum of standard light source "C"

Note (1) Light source is the BLU which is supplied by CMI and driving voltages are based on suitable gamma voltages. White is without signal input and R, G, B are with signal input. Spec is judged by CMI's golden sample.

Note (2) Definition of Viewing Angle ( $\theta_x$ ,  $\theta_y$ ):

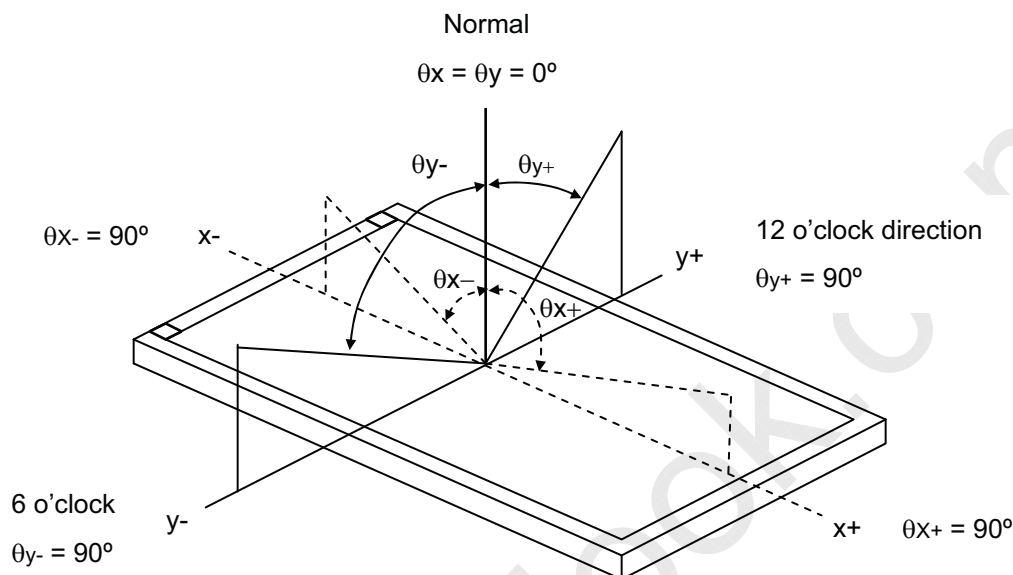

Note (3) Definition of Contrast Ratio (CR):

The contrast ratio can be calculated by the following expression.

$$\text{Contrast Ratio (CR)} = L_{63} / L_0$$

L63: Luminance of gray level 63

L 0: Luminance of gray level 0

$$\text{CR} = \text{CR} (1)$$

CR (X) is corresponding to the Contrast Ratio of the point X at Figure in Note (6).

Note (4) Definition of Response Time ( $T_R$ ,  $T_F$ ):

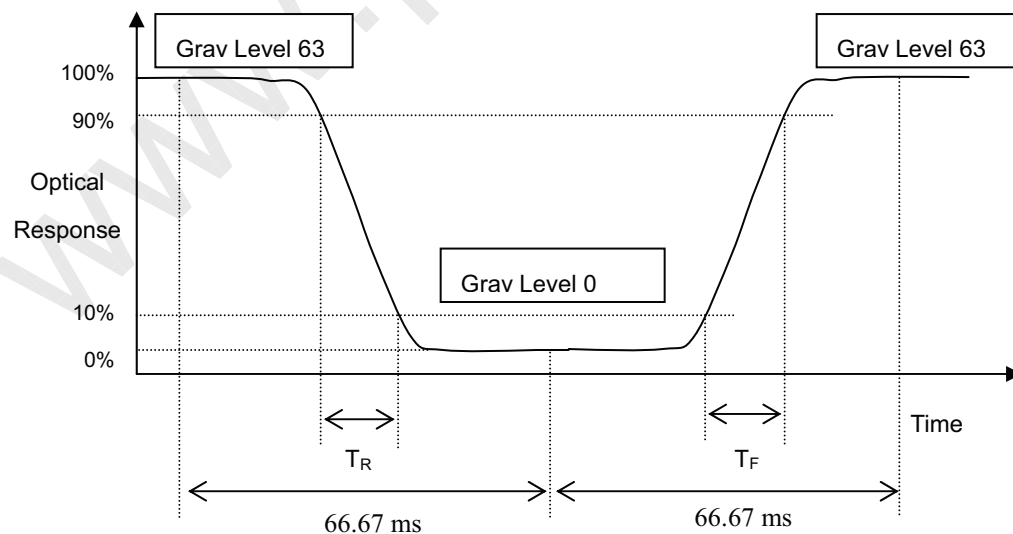

## Note (5) Measurement Setup:

The LCD module should be stabilized at given temperature for 20 minutes to avoid abrupt temperature change during measuring. In order to stabilize the luminance, the measurement should be executed after lighting Backlight for 20 minutes in a windless room.

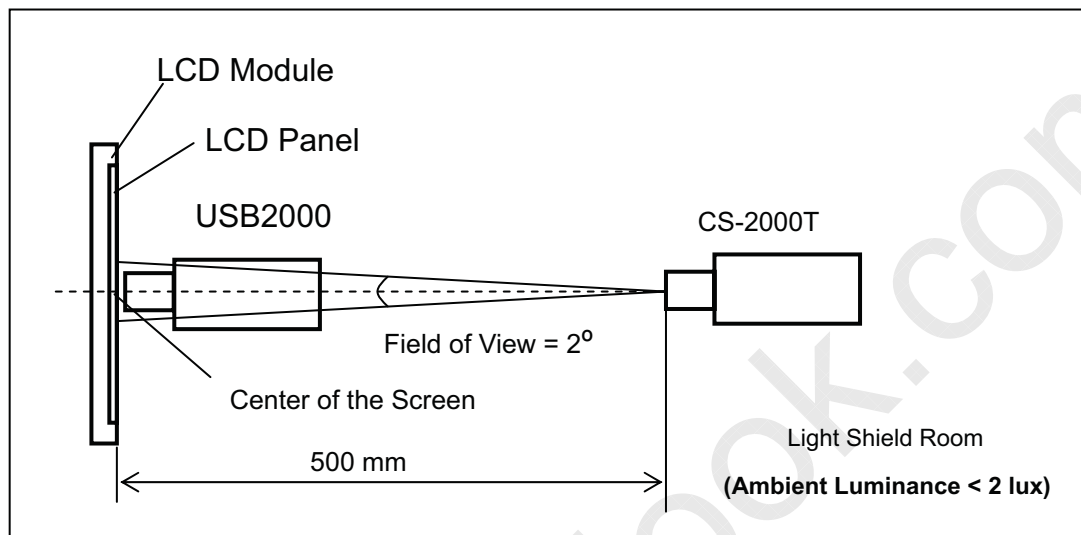

Note (6) The listed optical specifications refer to the initial value of manufacture, but the condition of the specifications after long-term operation will not be warranted.

## 6. PACKING

### 6.1 CMI OPEN CELL LABEL

The barcode nameplate is pasted on each OPEN CELL as illustration for CMI internal control.



- (a) Model Name: N173O6 - P02
- (b) Revision: Rev. XX, for example: C1, C2 ...etc.
- (c) Serial ID: XXXXXXXXYMDLNNNN

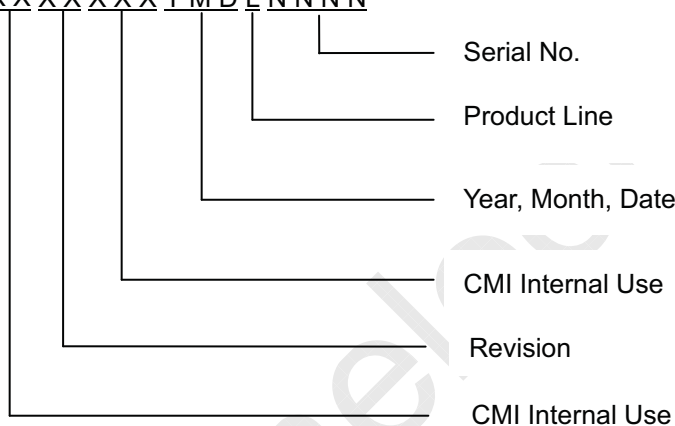

Serial ID includes the information as below:

- (a) Manufactured Date: Year: 0~9, for 2010~2019  
 Month: 1~9, A~C, for Jan. ~ Dec.  
 Day: 1~9, A~Y, for 1<sup>st</sup> to 31<sup>st</sup>, exclude I, O and U
- (b) Revision Code: cover all the change
- (c) Serial No.: Manufacturing sequence of product
- (d) Product Line: 1 -> Line1, 2 -> Line 2, ...etc.

## 6.2 PACKAGE RELIABILITY

(1) Carton Packing should have no failure in the following reliability test items

Test Item	Test Conditions	Note
Packing Vibration	ISTA STANDARD Random, Frequency Range: 1 – 200 Hz Top & Bottom: 30 minutes (+Z), 10 min (-Z), Right & Left: 10 minutes (X) Back & Forth 10 minutes (Y)	Non Operation

## 6.3 CARTON

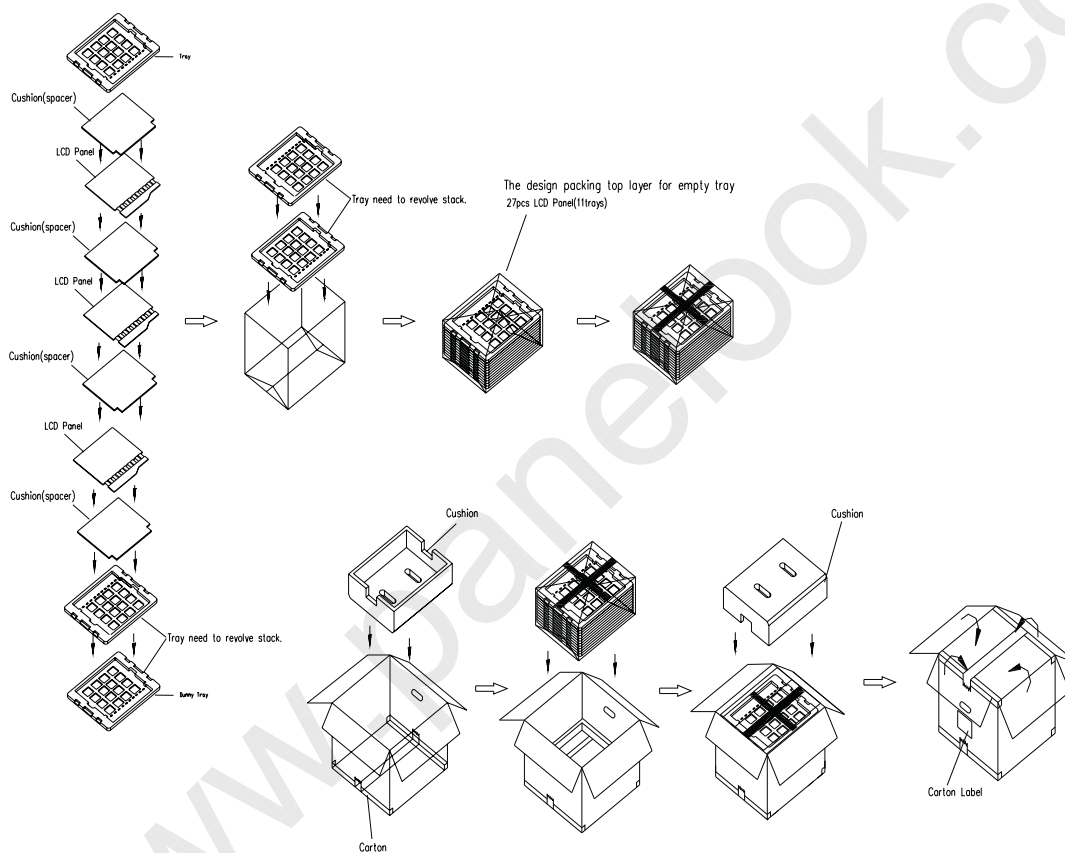

(1) Carton dimensions : 570(L)x450(W)x320(H)mm

(2) 27 LCD Cells+PCB/Carton

**Figure. 6-3 Packing method**

**6.4 PALLET**

Sea and Land Transportation

Air Transportation

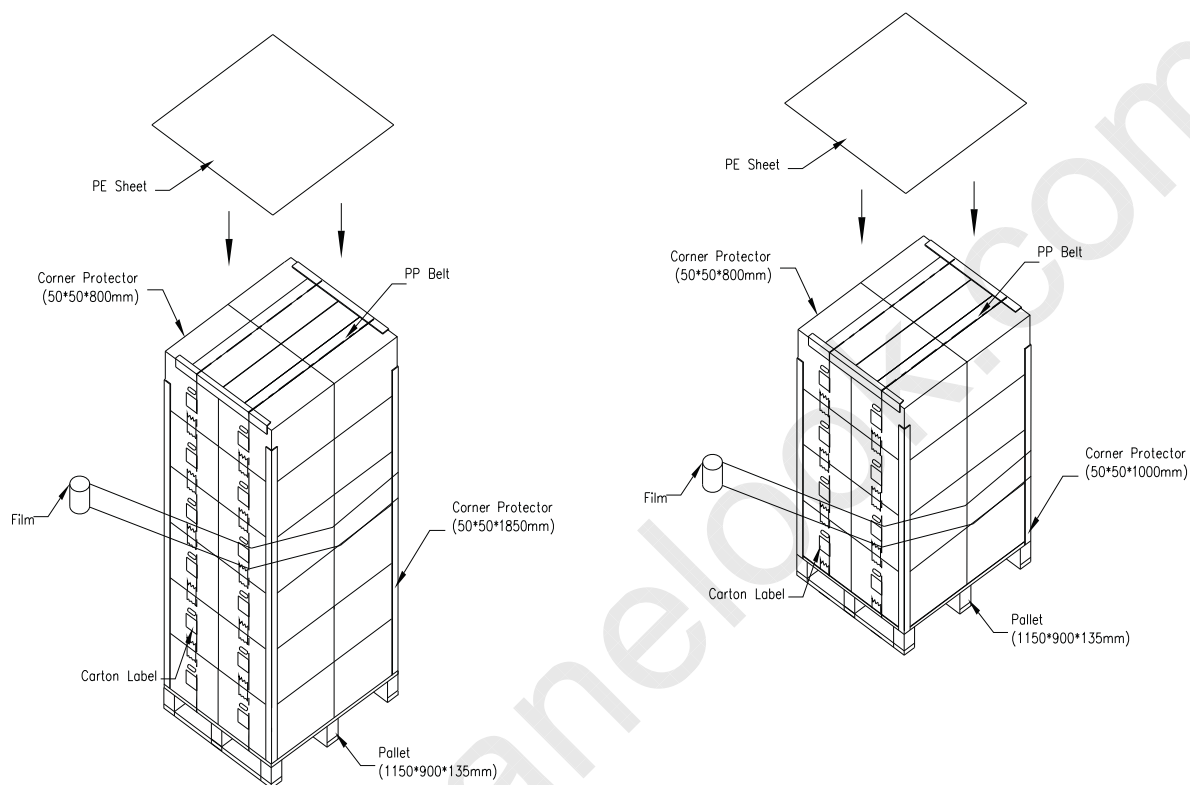
**Figure. 6-4 Packing method**



## 7. PRECAUTIONS

### 7.1 HANDLING PRECAUTIONS

- (1) The module should be assembled into the system firmly by using every mounting hole. Be careful not to twist or bend the module.
- (2) While assembling or installing modules, it can only be in the clean area. The dust and oil may cause electrical short or damage the polarizer.
- (3) Use fingerstalls or soft gloves in order to keep display clean during the incoming inspection and assembly process.
- (4) Do not press or scratch the surface harder than a HB pencil lead on the panel because the polarizer is very soft and easily scratched.
- (5) If the surface of the polarizer is dirty, please clean it by some absorbent cotton or soft cloth. Do not use Ketone type materials (ex. Acetone), Ethyl alcohol, Toluene, Ethyl acid or Methyl chloride. It might permanently damage the polarizer due to chemical reaction.
- (6) Wipe off water droplets or oil immediately. Staining and discoloration may occur if they left on panel for a long time.
- (7) If the liquid crystal material leaks from the panel, it should be kept away from the eyes or mouth. In case of contacting with hands, legs or clothes, it must be washed away thoroughly with soap.
- (8) Protect the module from static electricity, it may cause damage to the C-MOS Gate Array IC.
- (9) Do not disassemble the module.
- (10) Do not pull or fold the LED wire.
- (11) Pins of I/F connector should not be touched directly with bare hands.

### 7.2 STORAGE PRECAUTIONS

- (1) High temperature or humidity may reduce the performance of module. Please store LCD module within the specified storage conditions.
- (2) It is dangerous that moisture come into or contacted the LCD module, because the moisture may damage LCD module when it is operating.
- (3) It may reduce the display quality if the ambient temperature is lower than 10 °C. For example, the response time will become slowly, and the starting voltage of LED will be higher than the room temperature.

### 7.3 OPERATION PRECAUTIONS

- (1) Do not pull the I/F connector in or out while the module is operating.
- (2) Always follow the correct power on/off sequence when LCD module is connecting and operating. This can prevent the CMOS LSI chips from damage during latch-up.
- (3) The startup voltage of Backlight is approximately 1000 Volts. It may cause electrical shock while assembling with converter. Do not disassemble the module or insert anything into the Backlight unit.

Appendix. OUTLINE DRAWING

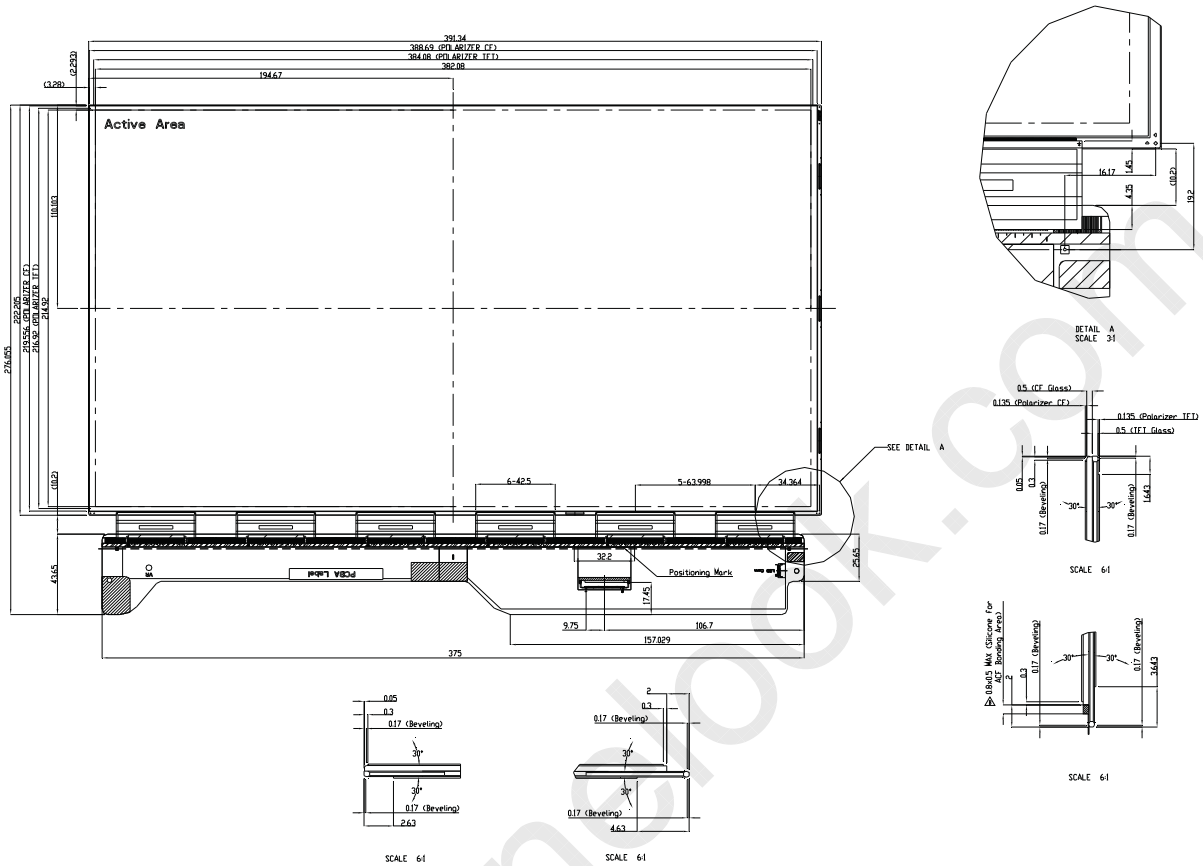

www.panelook.com