

# **N572F072/P072**

## **Data Sheet**

**32-BIT MULTI-ALGORITHM VOICE PROCESSOR  
(NuVoice™)**

# Table of Content

- 1. General Description ..... 3**
- 2. Features ..... 3**
- 3. Application Fields ..... 5**
- 4. Functional Block Diagram ..... 6**
- 5. Pin Configuration ..... 7**
  - 5.1 Pin Diagram ..... 7
  - 5.2 Pad Description ..... 8
  - 5.3 Alternate Function List of GPIO ..... 10
- 6. Typical Application Circuit ..... 12**
  - 6.1 Recording and Playback ..... 12
  - 6.2 Dual Microphones for Sound Direction Detection and Motor Control ..... 13
- 7. Software and Development Environment ..... 14**
  - 7.1 Development Environment ..... 14
  - 7.2 Library and Document Guide ..... 15
  - 7.3 Supported Codec ..... 16
- 8. Electrical Characteristics ..... 17**
  - 8.1 Absolute Maximum Ratings ..... 17
  - 8.2 DC Electrical Characteristics ..... 17
  - 8.3 AC Electrical Characteristics ..... 19
    - 8.3.1 Internal 48MHz RC Oscillator ..... 19
  - 8.4 Analog Characteristics ..... 19
    - 8.4.1 12-bit SAR ADC ..... 19
    - 8.4.2 Voice Recorder ..... 19
    - 8.4.3 1.8V LDO for Internal Core ..... 20
    - 8.4.4 Voutx (3.0V LDO) for External Driving ..... 20
    - 8.4.5 Low Voltage Reset ..... 20
    - 8.4.6 Voltage Detector ..... 20
    - 8.4.7 Power Amplifier and DAC ..... 20
    - 8.4.8 PLL ..... 21
- 9. Package Information ..... 22**
- 10. Ordering Information ..... 23**
- 11. Revision History ..... 23**

## 1. General Description

The N572F072 is the enhanced NuVoice™ series from N572F065. NuVoice is the first SoC specific for voice applications based on Cortex™-M0 CPU. It runs up to 48MHz and equips with 72KB flash and 8KB SRAM for high performance process of audio and voice algorithms. Integrating rich analog peripherals, like pre-amplifier, ADC, DAC, hardware mixer, and PA, this chip saves a lot of system design effort and cost.

To unfold the high performance M0 and high density of SRAM, advanced algorithms are designed, optimized, and tested with N572 chips. These algorithms include voice changer, low-bit rate compression – NuOne; NuSound; NuLite; NuVox, beat detection, pitch in and pitch out, talk2sing, and more in developing. In addition to algorithms developed by Nuvoton, we also seek third parties for more interesting features/software to enrich the applications on N572.

With the NVIC in M0, the latency of interrupt and response time to external events is very short and efficient. Multiple algorithms can be run together smoothly and naturally.

The development tools are based on Keil™ MDK using C/C++ programming language. This is a robust and easy to use environment for software development and debug. Features in Keil™ MDK are compiler, debugger, and profiler. With the Nu-Link™ and evaluation board, the overall system, including HW and SW, can work seamlessly in your system testing and verification. In this full-features development environment and tools, you can design and build application software in an efficient way and get optimized code that can best realize your idea on N572.

Following is a brief table of all Part No. of NuVoice Series:

Part No.	N572F072	N572P072	N572F065
Program ROM	72KB Flash	64KB OTP + 8KB Flash	64KB Flash
SRAM	8KB		
CPU freq	48MHz		
SPI Interface	Master/Slave mode 12MHz, 1 set Master mode 24MHz (3.3V), 1 set		Master mode 12MHz, 2 sets
USB	N/A	N/A	FS/12Mbps

## 2. Features

- **Core**
  - ARM® Cortex™-M0 core runs up to 48MHz
  - Support low power sleep mode
  - Single-cycle 32-bit hardware multiplier
  - NVIC for the 16 interrupt inputs, each with 4-level of priority
  - 24-bit SysTick timer
  - Serial Wire Debug supports with 2 watchpoints/4 breakpoints
- **Widely operating voltage range from 2.4V to 5.5V**
- **Flash Memory**
  - 72KB Flash (for N572F072)
  - 64KB OTP and 8KB Flash (for N572P072)
  - Support ISP for Flash update
  - 512 bytes page erase for Flash
  - Support 2-wire ICP update from ICE interface

- Security Lock preventing content in Flash access from external interface
- **SRAM Memory**
  - 8KB embedded SRAM
- **Clock Control**
  - Flexible selection for different applications
  - Support PLL, up to 48MHz, for high performance system operation
  - External 32KHz crystal input for RTC function and system clock
  - Internal 48MHz RC oscillator
- **GPIO**
  - Four I/O modes:
    - ◆ Quasi bi-direction
    - ◆ Push-Pull output
    - ◆ Open-Drain output
    - ◆ Input only with high impedance
  - TTL/Schmitt trigger input selectable
  - I/O pin can be configured as interrupt source with edge/level setting
- **Timers**
  - 3 sets of the timer with 8-bit pre-scaler and 16-bit timer.
  - Counter auto reload.
  - IR carrier generator
  - One fixed frequency timer
- **Watch Dog Timer**
  - Default ON/OFF by configuration setting
  - Multiple clock sources
  - 8 selectable time out period from around 32ms ~ 8sec (based on 32768Hz clock)
  - Able to wake up power down/sleep
  - Interrupt or reset selectable on watchdog time-out
- **RTC**
  - Support time out interrupt
  - Support wake up function
- **PWM Timer**
  - One 16-bit timer and four 16-bit comparators
  - Five clock selectors
  - One 8-bit pre-scaler and one clock divider
  - Two Dead-Zone generators
  - Programmable duty control of output waveform
  - Auto reload mode or one-shot pulse mode
  - Capture function
- **SPI**
  - Two sets of SPI device
  - Master mode up to 24MHz (3.3V)
  - Support master/slave mode
  - Full duplex synchronous serial data transfer
  - Variable length of transfer data from 1 to 32 bits
  - MSB or LSB first data transfer
  - Rx and Tx on both rising or falling edge of serial clock independently
  - 2 slave/device select lines

- Two 32-bit buffers
- **ADC**
  - 8-ch 12-bit with 320Ksps
  - Single scan/single cycle scan/continuous scan
  - 8 channels share 8 result registers
  - Programmable channel scan sequence
  - Threshold voltage detection
  - Conversion start by S/W or an external pin
  - Programmable gain control for sound record
  - Internal microphone bias
- **APU**
  - 13-bit DAC
  - H/W mixer with 2 channel PCM inputs
  - Embedded power amplifier
  - 7-level volume control
- **Voltage Detector**
  - with 2 levels: 3.0V/2.7V
- **LDO**
  - Built-in 1.8V LDO
- **Voltage Output**
  - Built-in 3V regulator power supply Voutx for driving external spi-flash
- **Low Voltage Reset 1.8V**
- **Operating Temperature: 0°C~70°C**
- **Packages:**
  - All Green package (RoHS)
  - 7mmx7mm LQFP 64-pin or COB

### 3. Application Fields

- **Recordable story books**
- **Karaoke musical player**
- **Toy masks with voice change**
- **Voice recognition toys**
- **Interactive toys on learning of music, languages**
- **Toy robots**

### 4. Functional Block Diagram

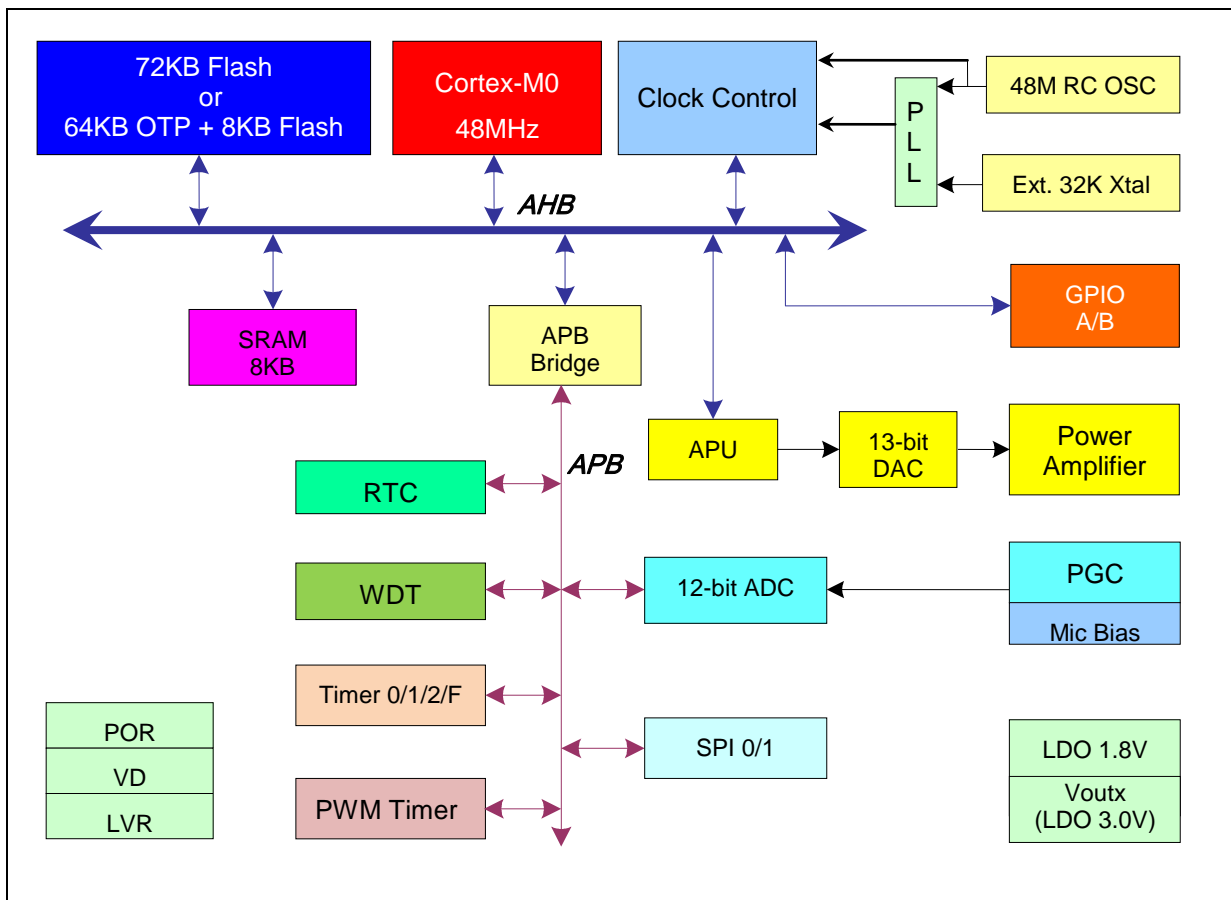

## 5. Pin Configuration

### 5.1 Pin Diagram

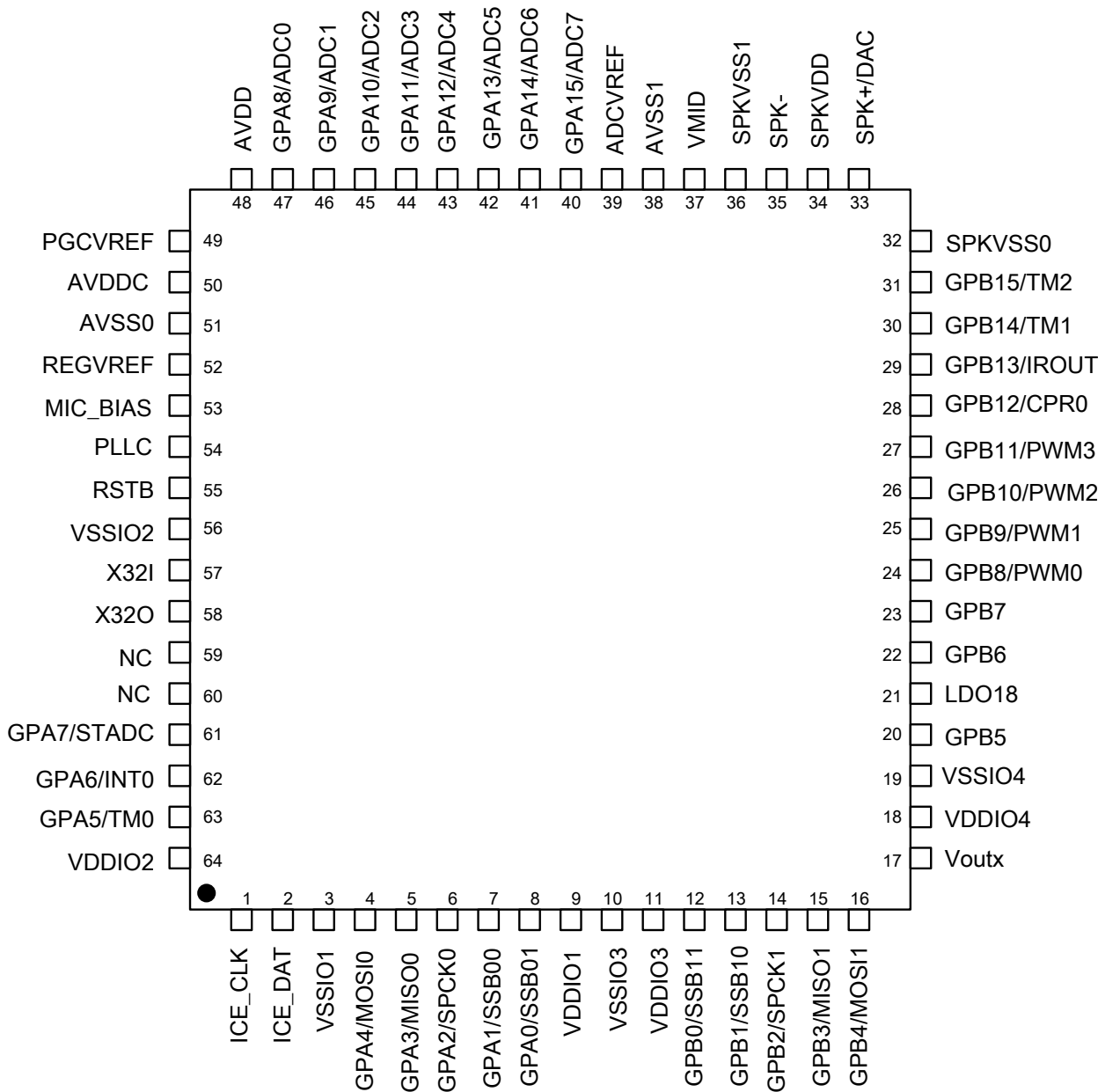

## 5.2 Pad Description

Name	Type	Description
<b>1. GPIO</b>		
GPA0 GPA15	~ I/O	Bidirectional general purpose I/O ports. Most of these pins have alternate function, refer to section 5.3 for detail.
GPB0 GPB15	~ I/O	Bidirectional general purpose I/O ports. Most of these pins have alternate function, refer to section 5.3 for detail.
<b>2. Oscillator</b>		
X32I	I	32KHz crystal input
X32O	O	32KHz crystal output
PLLC	A	Capacitor connection for built-in PLL1
<b>3. PGC and ADC</b>		
AVDD	P	Analog power supply
AVSS0	P	Analog ground
AVSS1	P	Analog ground
ADCVREF	A	Reference voltage input for ADC
MIC_BIAS	A	Microphone bias output
AVDDC	A	Regulator output pin for ADC and PGC, its output voltage is 0.85xAVDD. Connect an external 4.7uF capacitor to AVSS.
PGCVREF	A	AVDDC/2 for PGC. A 4.7uF (or higher) capacitor for low pass filter to filter power noise is needed.
REGVREF	A	AVDD/2 for microphone output. A 4.7uF (or higher) capacitor for low pass filter to filter power noise is needed.
<b>4. Speaker Driver</b>		
DAC/SPK+	O	Speaker positive output pin, or current type DAC output.
SPK-	O	Speaker negative output pin.
SPKVDD	P	Analog power supply
SPKVSS1	P	Analog ground.
SPKVSS0	P	Analog ground.
VMID	A	Connect a capacitor to SPKVSS1
<b>5. Power</b>		
VDDIO4	P	Power supply for I/O port, LVR, LVD and source of LDO.



VSSIO4	P	Ground pin, connect to 0V.
VDDIO2	P	Power supply for I/O port, SWD, and RSTB
VSSIO2	P	Ground pin, connect to 0V.
VDDIO1	P	Power supply for I/O port.
VSSIO1	P	Ground pin, connect to 0V.
VDDIO3	P	Power supply for I/O port.
VSSIO3	P	Ground pin, connect to 0V.
LDO18	P	1.8V LDO output
Voutx	P	3.0V regulator output for driving external
<b>6. SWD</b>		
ICE_CLK	I	Serial Wired Debugger Clock pin
ICE_DAT	I/O	Serial Wired Debugger Data pin
<b>7. Other</b>		
RSTB	I	Reset input pin, low active. Internal pull-high.

### 5.3 Alternate Function List of GPIO

<b>GPIO</b>	<b>Power</b>	<b>Alternate</b>	<b>I/O of Alternate</b>	<b>Function Description</b>
GPA0	VDDIO1	SSB01	O	SPI0 2 <sup>nd</sup> chip select pin
GPA1	VDDIO1	SSB00	O	SPI0 1 <sup>st</sup> chip select pin
GPA2	VDDIO1	SPCK0	O	SPI0 serial clock output
GPA3	VDDIO1	MISO0	I	SPI0 master data input
GPA4	VDDIO1	MOSI0	O	SPI0 master data output
GPA5	VDDIO2	TM0	I	Timer0 counter external clock input
GPA6	VDDIO2	INT0	I	External interrupt input pin
GPA7	VDDIO2	STADC	I	ADC external trigger input
GPA8	AVDD	ADC0	A	ADC analog input 0
GPA9	AVDD	ADC1	A	ADC analog input 1
GPA10	AVDD	ADC2	A	ADC analog input 2
GPA11	AVDD	ADC3	A	ADC analog input 3
GPA12	AVDD	ADC4	A	ADC analog input 4
GPA13	AVDD	ADC5	A	ADC analog input 5
GPA14	AVDD	ADC6	A	ADC analog input 6
GPA15	AVDD	ADC7	A	ADC analog input 7
GPB0	VDDIO3	SSB11	O	SPI1 2nd chip select output pin
GPB1	VDDIO3	SSB10	I/O	SPI1 1st chip select output/input pin
GPB2	VDDIO3	SPCK1	I/O	SPI1 serial clock output/input
GPB3	VDDIO3	MISO1	I/O	SPI1 master data input, slave data output
GPB4	VDDIO3	MOSI1	I/O	SPI1 master data output, slave data input
GPB5	VDDIO4	-		
GPB6	VDDIO4	-		
GPB7	VDDIO4	-		
GPB8	VDDIO4	PWM0	O	PWM output pin 0
GPB9	VDDIO4	PWM1	O	PWM output pin 1

GPB10	VDDIO4	PWM2	O	PWM output pin 2
GPB11	VDDIO4	PWM3	O	PWM output pin 3
GPB12	VDDIO4	CPR0	I	Capture input
GPB13	VDDIO4	IROUT	O	IR carrier output
GPB14	VDDIO4	TM1	I	Timer1 counter external clock input
GPB15	VDDIO4	TM2	I	Timer2 counter external clock input

I: Input, O: Output, A: Analog input

## 6. Typical Application Circuit

### 6.1 Recording and Playback

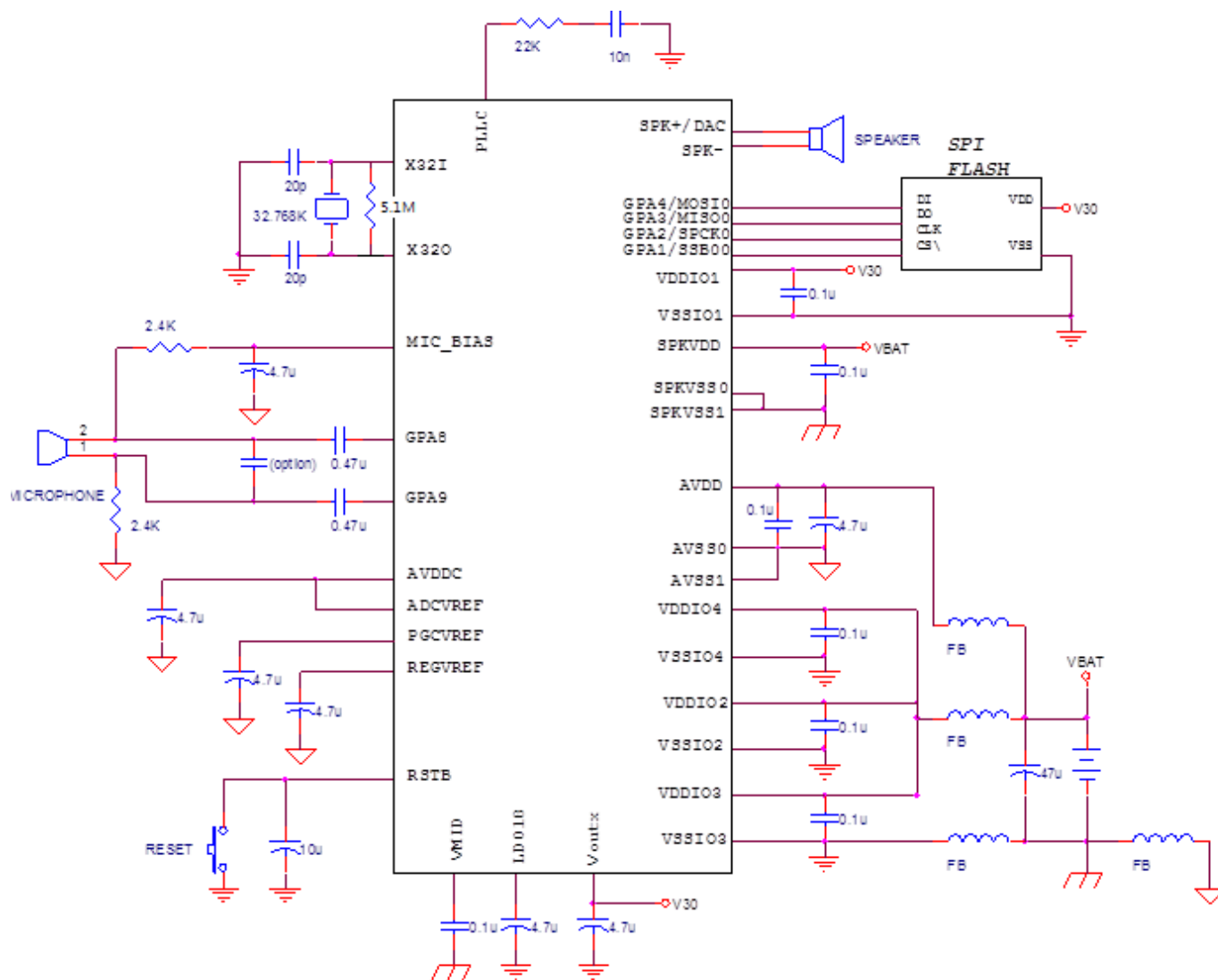

## 6.2 Dual Microphones for Sound Direction Detection and Motor Control

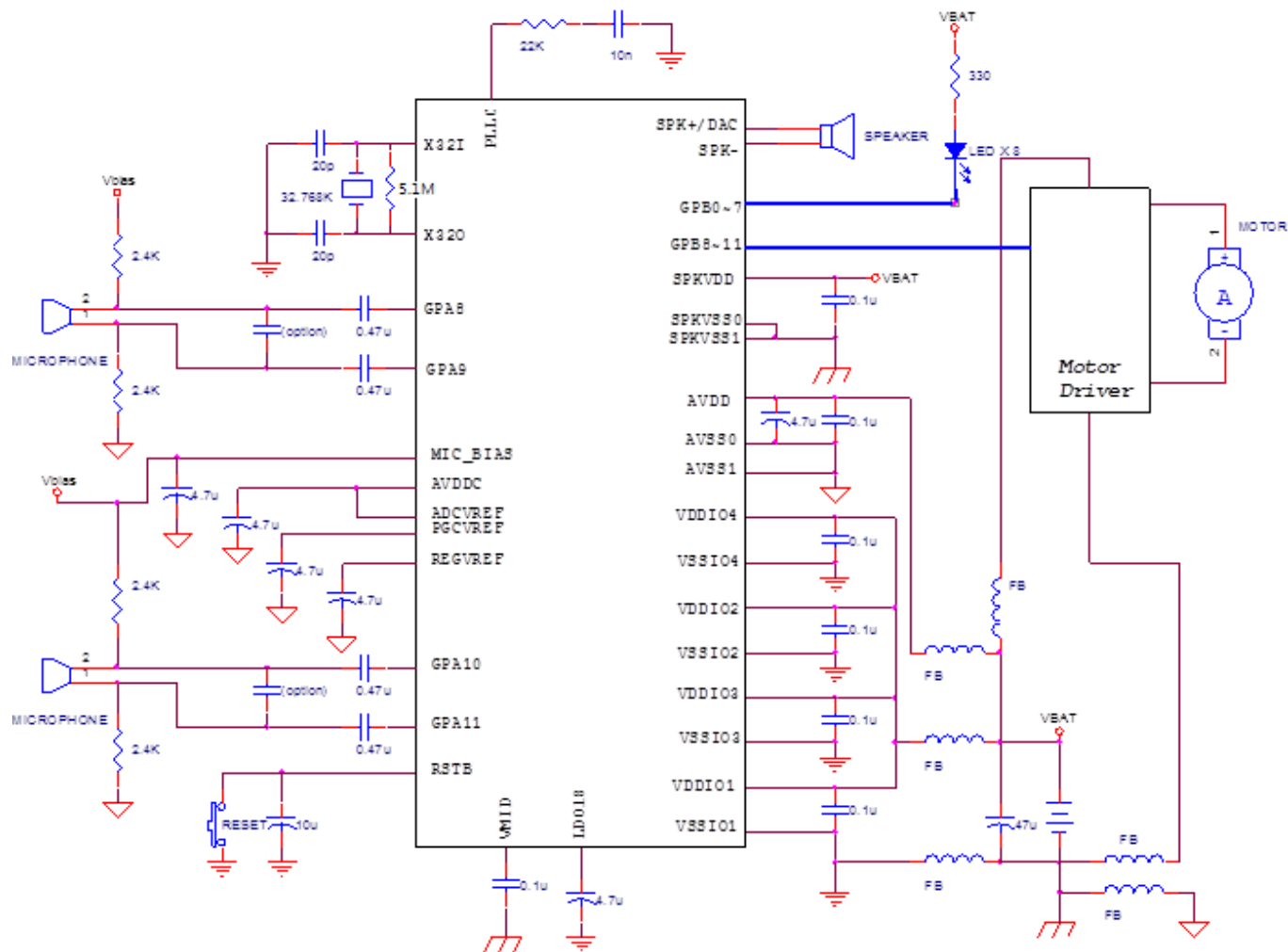

## 7. Software and Development Environment

### 7.1 Development Environment

The Keil™ MDK includes IDE, compiler, linker, and debugger is for your software development. Debug hardware requires Nu-Link™ and N572 EVB. A Nu-Link driver is required to add views of peripherals and add-ons within MDK's IDE. With software library, you can develop and debug in the MDK environment. Please refer to Programming Guide for details.

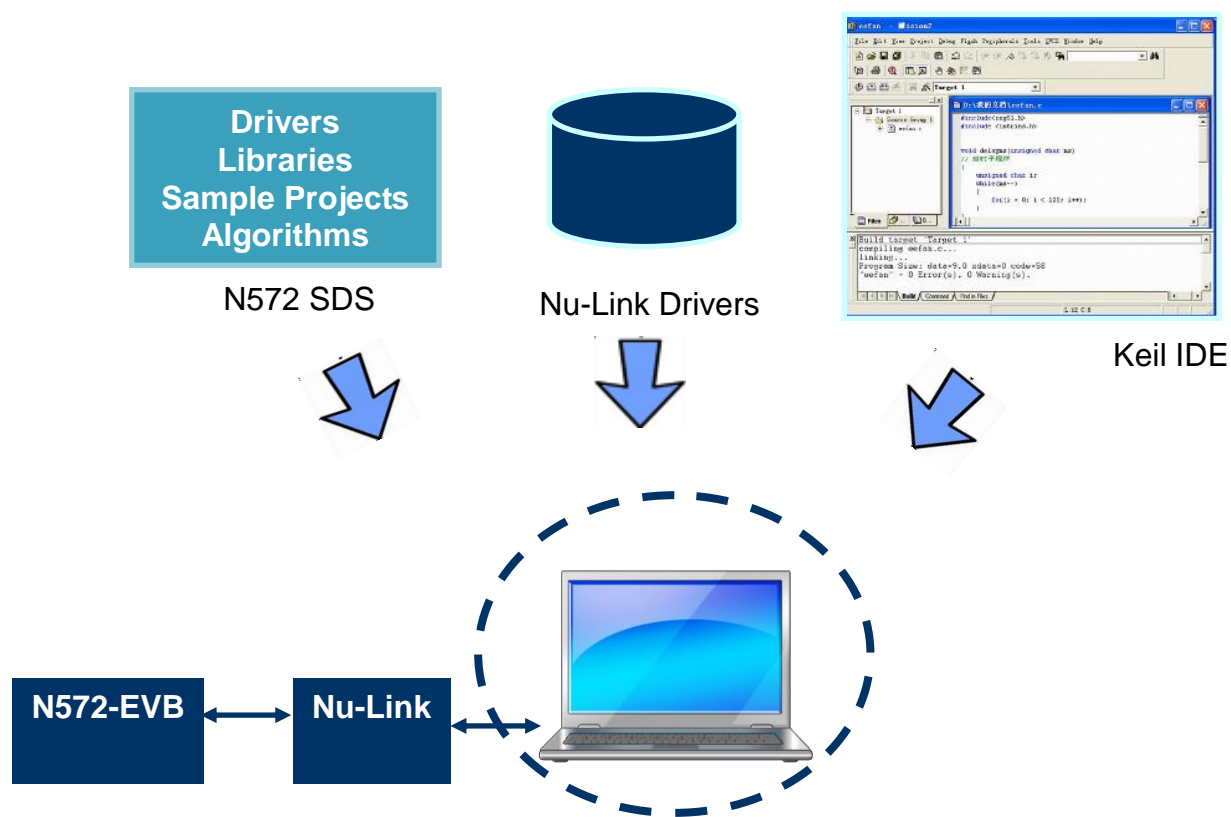

## 7.2 Library and Document Guide

N572 SDS is for N572F072/P072/F065 which provides a bunch of sample codes, libraries, document, and EVB schematic for your reference. To get familiar with the whole development environment, please install Keil then this SDS. There will be a **N572 SDS Document Index** under **N572 SDS Vxxx** from Start menu to show all the useful information. Even better is the links to directly open Keil and load sample projects in a click!

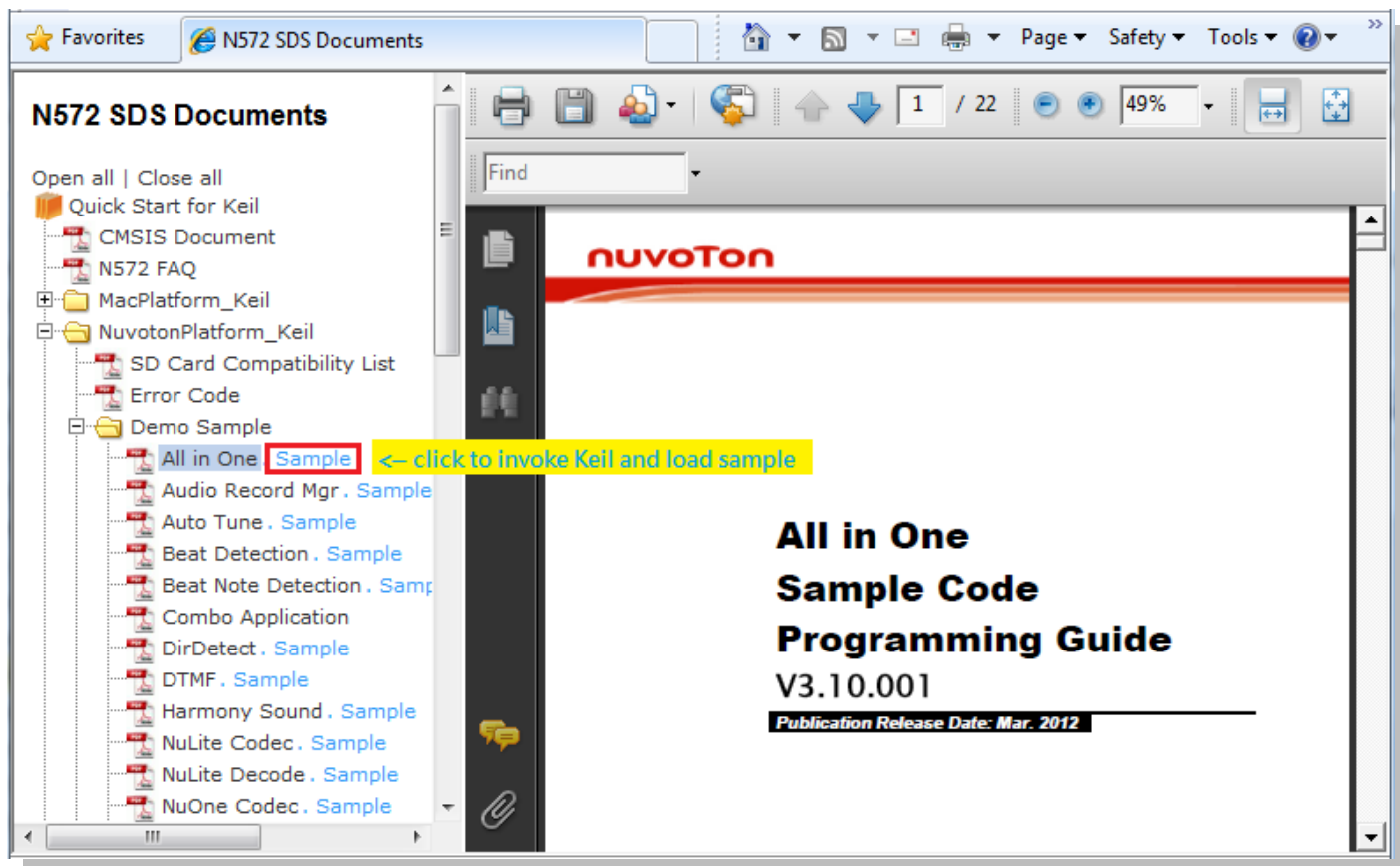

The algorithms are collected in library. **Demo Sample** is also a good place for user to understand the capability of NuVoice™.

### 7.3 Supported Codec

Following table shows the supported codec and suggested sample rate and corresponding bit rate. The Bit Rate of NuOne, NuLite, and NuSound could be configurable. For example, using 8K sample rate, the bit rate could be 8Kbps (1bit per sample) or 12Kbps (1.5 bit per sample) or 16Kbps (2 bit per sample). Details please refer to document in SDS.

Codec	Sample Rate (Hz) *note1	Bit Rate (bps)	For	Availability
NuOne	8K~20K	8K ~ 20K @1b/sample *note2	Speech, Music	Codec
NuLite	8K~12K	9.6K ~ 14.4K @1.2b/sample *note2	Speech, Music	Codec
NuSound	8K~20K	16K~40K @2b/sample *note3	Speech, Music	Decoder
MD4	8K~20K	32K~80K	Speech, Music	Decoder
IMAADPCM	8K~20K	32K~80K	Speech, Music	Codec
LP8	8K~20K	64K~160K	Speech, Music	Codec
NuVox24	8K	2.4K	Speech	Decoder
NuVox53/63	8K	5.3K/6.3K	Speech	Decoder

\*note1: suggested sampling rate

\*note2: bits per sample range from 0.5b/sample ~ 3b/sample, with 0.1b/sample incremental step

\*note3: bits per sample range from 1.5b/sample ~ 3b/sample, with 0.1b/sample incremental step



## 8. Electrical Characteristics

### 8.1 Absolute Maximum Ratings

SYMBOL	PARAMETER	MIN	MAX	UNIT	
	DC Power Supply	VDD-VSS	-0.3	+7.0	V
	Input Voltage	VIN	VSS-0.3	VDD+0.3	V
	Oscillator Frequency	1/t <sub>CLCL</sub>	0	48	MHz
	Operating Temperature	TA	0	+70	°C
	Storage Temperature	TST	-55	+150	°C
	Maximum Current into V <sub>DD</sub>		-	120	mA
	Maximum Current out of V <sub>SS</sub>			120	mA
	Maximum Current sunk by an I/O pin			35	mA
	Maximum Current sourced by an I/O pin			35	mA
	Maximum Current sunk by total I/O pins			100	mA
	Maximum Current sourced by total I/O pins			100	mA

### 8.2 DC Electrical Characteristics

VDD-VSS=4.5V, TA=25°C, unless otherwise specified.

PARAMETER	SYM	SPECIFICATION				TEST CONDITIONS
		MIN.	TYP.	MAX.	UNIT	
Operation voltage	V <sub>DD</sub>	2.4		5.5	V	
Power Ground	V <sub>SS</sub> AV <sub>SS</sub>	-0.3			V	
Analog Operating Voltage	AV <sub>DD</sub>	0		V <sub>DD</sub>	V	
Analog Reference Voltage	V <sub>ref</sub>	0		AV <sub>DD</sub>	V	
Operating Current at Normal Run Mode	I <sub>DD1</sub>		20		mA	V <sub>DD</sub> =5.5V@48MHz, enable all IPs' clock
	I <sub>DD3</sub>		18		mA	V <sub>DD</sub> =3V@48MHz, enable all IPs' clock
Operating Current at Idle Mode	I <sub>IDLE2</sub>		3		mA	V <sub>DD</sub> =5.5V@48MHz, disable all IPs
	I <sub>IDLE4</sub>		3		mA	V <sub>DD</sub> =3V@48MHz, disable all IPs
Operating Current at Power-down Mode	I <sub>PWD1</sub>		10	15	μA	V <sub>DD</sub> = 5.5V, No load, disable Voutx, LVD, LVR, ...
	I <sub>PWD2</sub>		9	15	μA	V <sub>DD</sub> = 3.3V, No load, disable Voutx,

						LVD, LVR, ...
Input Current GPA/GPB	$I_{IN1}$	-60	-	+15	$\mu\text{A}$	$V_{DD} = 5.5\text{V}$ , $V_{IN} = 0\text{V}$ or $V_{IN}=V_{DD}$
Input Current at RSTB <sup>[1]</sup>	$I_{IN2}$	-160	-130	-100	$\mu\text{A}$	$V_{DD} = 5.5\text{V}$ , $V_{IN} = 0.45\text{V}$
Input Leakage Current GPA/GPB	$I_{LK}$	-0.1	-	+0.1	$\mu\text{A}$	$V_{DD} = 5.5\text{V}$ , $0 < V_{IN} < V_{DD}$
Input Low Voltage GPIO (TTL input)	$V_{IL1}$	-0.3	-	1.0	V	$V_{DD} = 4.5\text{V}$
		-0.3	-	0.6		$V_{DD} = 2.4\text{V}$
Input High Voltage GPIO (TTL input)	$V_{IH1}$	2.2	-	$V_{DD} + 0.2$	V	$V_{DD} = 5.5\text{V}$
		1.5	-	$V_{DD} + 0.2$		$V_{DD} = 3.0\text{V}$
Source Current GPA/GPB (Quasi-bidirectional Mode)	$I_{SR11}$	-300	-370	-450	$\mu\text{A}$	$V_{DD} = 4.5\text{V}$ , $V_S = 2.4\text{V}$
	$I_{SR12}$	-50	-70	-90		$V_{DD} = 2.7\text{V}$ , $V_S = 2.2\text{V}$
	$I_{SR13}$	-40	-60	-80		$V_{DD} = 2.5\text{V}$ , $V_S = 2.0\text{V}$
Source Current GPA/GPB (Push-pull Mode)	$I_{SR21}$	-20	-24	-28	mA	$V_{DD} = 4.5\text{V}$ , $V_S = 3.0\text{V}$
	$I_{SR22}$	-4	-6	-8		$V_{DD} = 2.7\text{V}$ , $V_S = 2.2\text{V}$
	$I_{SR23}$	-3	-5	-7		$V_{DD} = 2.5\text{V}$ , $V_S = 2.0\text{V}$
Sink Current GPA/GPB (Quasi-bidirectional and Push-pull Mode)	$I_{SK1}$	10	16	20	mA	$V_{DD} = 4.5\text{V}$ , $V_S = 0.45\text{V}$
	$I_{SK2}$	7	10	13		$V_{DD} = 2.7\text{V}$ , $V_S = 0.45\text{V}$
	$I_{SK3}$	6	9	12		$V_{DD} = 2.5\text{V}$ , $V_S = 0.45\text{V}$

**Notes:** 1. RSTB pin is a Schmitt trigger input.

### 8.3 AC Electrical Characteristics

The following data are measured under VDD-VSS=4.5V, TA=25°C, unless otherwise specified.

#### 8.3.1 Internal 48MHz RC Oscillator

PARAMETER	CONDITION	MIN.	TYP.	MAX.	UNIT
Center Frequency			48.24		MHz
Calibrated Internal Oscillator Frequency	+25°C	-1		+1	%
Operating current	V <sub>DD</sub> =1.8V		900		uA

### 8.4 Analog Characteristics

The following data are measured under VDD-VSS=4.5V, TA=25°C, unless otherwise specified.

#### 8.4.1 12-bit SAR ADC

PARAMETER	SYM.	MIN.	TYP.	MAX.	UNIT
Resolution	-	-	-	12	Bit
Differential nonlinearity error	DNL	-	±1	-	LSB
Integral nonlinearity error	INL	-	±1	-	LSB
Offset error	EO	-	±1	-	LSB
Gain error (Transfer gain)	EG	-	1	-	-
Monotonic	-	Guaranteed			-
ADC clock frequency	FADC	-	-	8	MHz
Sample & Conversion time	TADC	-	25	-	Clock
Sample rate	FS	-	-	320	Ksps
Supply voltage	VDD	-	1.8	-	V
	VDDA	3	-	5.5	V
Supply current (Avg.)	IDD	-	0.5	-	mA
	I <sub>DDA</sub>	-	1.5	-	mA
Reference voltage	VREFP	-	VDDA	-	V

#### 8.4.2 Voice Recorder

Parameter	Sym.	Condition	Min.	Typ.	Max.	Unit
Operation Voltage	VDDA		3	5	5.5	V

Operation Current	IDD			3.5		mA
Programmable Gain	PG		0		30	dB
Preamp Gain	PAG		20		40	dB
Offset Bit	OS	9-bit Control	-64		64	mV
THD+N	THD+N	Preamp Gain=40dB, Programmable Gain=0dB		-55		dB

**8.4.3 1.8V LDO for Internal Core**

Parameter	Condition	MIN.	TYP.	MAX.	Unit
Input Voltage		2.4	5	5.5	V
Output Voltage		--	1.8	--	V

**8.4.4 Voutx (3.0V LDO) for External Driving**

Parameter	Condition	Min.	Typ.	Max.	Unit
Input Voltage		3.3	5	5.5	V
Output Voltage		-10%	3.0	+10%	V
	Turn off		floating	-	V
I <sub>load</sub>				40	mA

**8.4.5 Low Voltage Reset**

PARAMETER	CONDITION	MIN.	TYP.	MAX.	UNIT
Threshold voltage	Temperature=25°C	1.6	1.8	2.0	V

**8.4.6 Voltage Detector**

PARAMETER	CONDITION	MIN.	TYP.	MAX.	UNIT
Detected Voltage	CVDTV=0		2.7		V
	CVDTV=1		3.0		V

**8.4.7 Power Amplifier and DAC**

PARAMETER	CONDITION	MIN.	TYP.	MAX.	UNIT
Operation voltage	SPKVDD	2.4	4.5	5.5	V
Output Power	SPKVDD=4.5V, 8Ω BTL load, 0dB gain		400		mW

Total Harmonic Distortion	SPKVDD=4.5V, 8Ω BTL load, 0dB gain, 400mW		-48		dB
Power Amplifier Gain		-18		0	dB
DAC output current	DACGN=0	2.4	3	3.6	mA
	DACGN=1	4.0	5.0	6.0	
DAC operation Current	SPKVDD=4.5V		4		mA
DAC Quiescent Current	SPKVDD=4.5V		200		μA
Power Amplifier Quiescent Current	DAC fine-tuned, SPKVDD=4.5V		6		mA
Power Down Current	DAC fine-tuned, SPKVDD=4.5V		1		μA
Operation Current	SPKVDD=4.5V, 400mW		250		mA

**8.4.8 PLL**

PARAMETER	SYMBOL	CONDITION	MIN.	TYP.	MAX.	UNIT
Operating Voltage Range	VDD		--	1.8	--	V
Temperature			0	25	70	°C
Input Clock Frequency	Fin		--	32.768	--	KHz
Output Clock Frequency	Fout		--	48	--	MHz
Duty Cycle	--	Fout=48MHz	40	50	60	%
Operating Current	Iop	25°C		3		mA

## 9. Package Information

64L LQFP(7x7x1.4mm footprint 2.0mm)

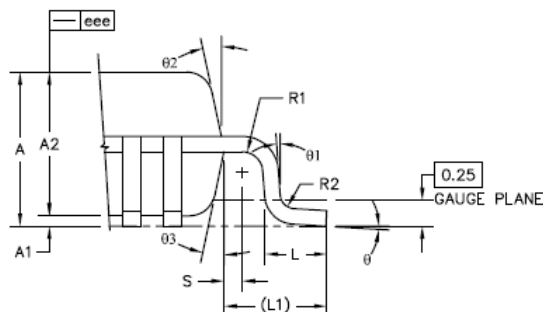
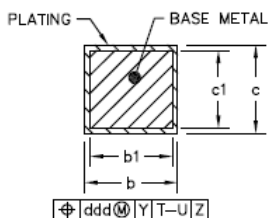
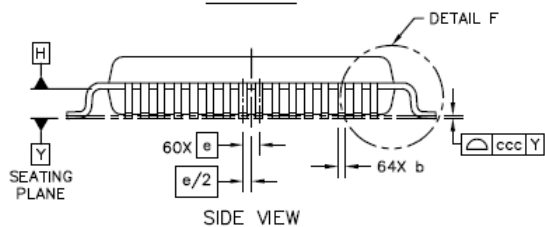
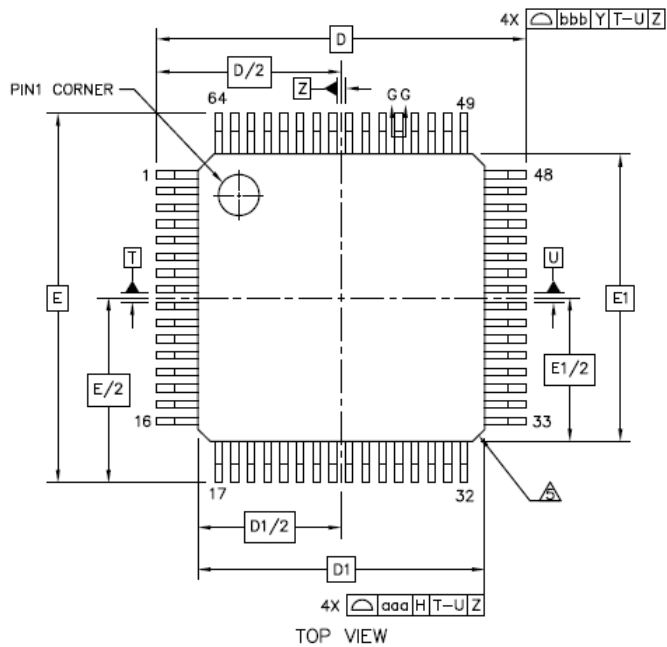

	SYMBOL	MIN	NOM	MAX
TOTAL THICKNESS	A	----	----	1.6
STAND OFF	A1	0.05	----	0.15
MOLD THICKNESS	A2	1.35	1.4	1.45
LEAD WIDTH(PLATING)	b	0.13	0.18	0.23
LEAD WIDTH	b1	0.13	0.16	0.19
L/F THICKNESS(PLATING)	c	0.09	----	0.2
L/F THICKNESS	c1	0.09	----	0.16
BODY SIZE	X	D	9 BSC	
	Y	E	9 BSC	
LEAD PITCH	X	D1	7 BSC	
	Y	E1	7 BSC	
LEAD PITCH	e	0.4 BSC		
FOOTPRINT	L	0.45	0.6	0.75
	L1	1 REF		
	θ	0°	3.5°	7°
	θ1	0°	----	----
	θ2	11°	12°	13°
	θ3	11°	12°	13°
	R1	0.08	----	----
	R2	0.08	----	0.2
	S	0.2	----	----
PACKAGE EDGE TOLERANCE	aaa	0.2		
LEAD EDGE TOLERANCE	bbb	0.2		
COPLANARITY	ccc	0.08		
LEAD OFFSET	ddd	0.07		
MOLD FLATNESS	eee	0.05		

## 10. Ordering Information

PART NUMBER	PACKAGE	SPECIAL FEATURE	PB FREE + HALOGEN FREE (GREEN)	RELEASE DATE
N572F072	NA (Die Form)	MTP	Yes	Available
N572F072G	LQFP 64pin 7mmx7mm	MTP	Yes	Available
N572P072	NA (Die Form)	OTP + MTP	Yes	Available
N572P072G	LQFP 64pin 7mmx7mm	OTP + MTP	Yes	Available

## 11. Revision History

VERSION	DATE	DESCRIPTIONS
1.0	Oct, 2011	Preliminary draft
1.1	May, 2012	Review to make official release
1.2	Nov, 2012	Add codec table Add section of Application Fields Keep only 64KB OTP+ 8KB Flash for N572P072
1.3	Aug, 2013	Update Operating Temperature as 0°C~70°C Update application circuit Remove supply voltage VDD & un-calibrated part in 8.3.1 table Update minimum input spec of SPKVDD & 1.8V LDO to 2.4V.
1.4	Aug, 2014	Update Internal RC 48MHz Center Frequency as 48.24MHz (typical) Update Calibrated Internal Oscillator Frequency as ±1% Correct Voice Recorder THD+N as -55dB (typical)

### Important Notice

Nuvoton Products are neither intended nor warranted for usage in systems or equipment, any malfunction or failure of which may cause loss of human life, bodily injury or severe property damage. Such applications are deemed, "Insecure Usage".

Insecure usage includes, but is not limited to: equipment for surgical implementation, atomic energy control instruments, airplane or spaceship instruments, the control or operation of dynamic, brake or safety systems designed for vehicular use, traffic signal instruments, all types of safety devices, and other applications intended to support or sustain life.

All Insecure Usage shall be made at customer's risk, and in the event that third parties lay claims to Nuvoton as a result of customer's Insecure Usage, customer shall indemnify the damages and liabilities thus incurred by Nuvoton.

---

*Please note that all data and specifications are subject to change without notice.  
All the trademarks of products and companies mentioned in this datasheet belong to their respective owners.*