

54/74122

DESCRIPTION

These retriggerable monostable multi-vibrators feature dc triggering from gated active LOW inputs (\bar{A}) and active HIGH inputs (B) and also provide overriding direct reset inputs. Complementary outputs are provided. The retrigger capability simplifies the generation of output pulses of extremely long duration. By triggering the input before the output pulse is terminated, the output pulse may be extended. The overriding reset capability permits any output pulse to be terminated at a predetermined time independently of the timing components R and C.

FEATURES

- DC Triggered from active HIGH or active LOW inputs
- Retriggerable for very long pulses—up to 100% duty cycle
- Direct Reset terminates output pulse
- Compensated for V_{CC} and temperature variations

PIN CONFIGURATION

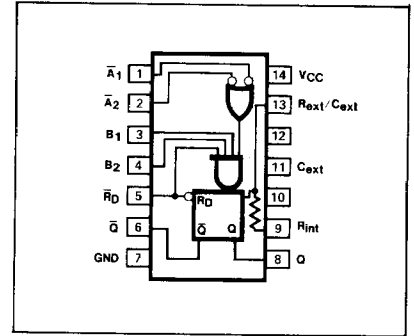

FUNCTION TABLE

INPUTS					OUTPUTS	
\bar{R}_D	\bar{A}_1	\bar{A}_2	B ₁	B ₂	Q	\bar{Q}
L	X	X	X	X	L	H
X	H	H	X	X	L	H
X	X	X	L	X	L	H
X	X	X	X	L	L	H
H	L	X	↑	H	[Active HIGH pulse]	[Active LOW pulse]
H	L	X	H	↑	[Active HIGH pulse]	[Active LOW pulse]
H	X	L	↑	H	[Active HIGH pulse]	[Active LOW pulse]
H	X	L	H	↑	[Active HIGH pulse]	[Active LOW pulse]
H	H	↓	H	H	[Active HIGH pulse]	[Active LOW pulse]
H	↓	↓	H	H	[Active HIGH pulse]	[Active LOW pulse]
H	↓	H	H	H	[Active HIGH pulse]	[Active LOW pulse]
↑	L	X	H	H	[Active HIGH pulse]	[Active LOW pulse]
↑	X	L	H	H	[Active HIGH pulse]	[Active LOW pulse]

H = HIGH voltage level
 L = LOW voltage level
 X = Don't care
 ↑ = LOW-to-HIGH input transition
 ↓ = HIGH-to-LOW input transition
 [Active HIGH pulse] = Active HIGH pulse
 [Active LOW pulse] = Active LOW pulse

ORDERING CODE (See Section 9 for further Package and Ordering Information)

PACKAGES	COMMERCIAL RANGES	MILITARY RANGES
	$V_{CC}=5V \pm 5\%$; $T_A=0^\circ C$ to $+70^\circ C$	$V_{CC}=5V \pm 10\%$; $T_A=-55^\circ C$ to $+125^\circ C$
Plastic DIP	N74122N	
Ceramic DIP	B74122F	S54122F
Flatpak		S54122W

INPUT AND OUTPUT LOADING AND FAN-OUT TABLE^(a)

PINS	DESCRIPTION		54/74	54S/74S	54LS/74LS
\bar{A}_1, \bar{A}_2	Trigger (active LOW) inputs	I_{IH} (μA) I_{IL} (mA)	40 -1.6		
B ₁ , B ₂	Trigger (active HIGH) inputs	I_{IH} (μA) I_{IL} (mA)	40 -1.6		
\bar{R}_D	Direct Reset (active LOW) input	I_{IH} (μA) I_{IL} (mA)	80 -3.2		
Q	Pulse (active HIGH) output	I_{OH} (μA) I_{OL} (mA)	-800 16		
\bar{Q}	Pulse (active LOW) output	I_{OH} (μA) I_{OL} (mA)	-800 16		

NOTE

a. The slashed numbers indicate different parametric values for Military/Commercial temperature ranges respectively.

FUNCTIONAL DESCRIPTION

The "122" is a retriggerable monostable multivibrator featuring output pulse width control by three methods. The basic pulse time is programmed by selection of external resistance and capacitance values (see typical application data in "123" data sheet). The "122" has an internal timing resistor that allows the circuit to be used with only an external capacitor, if so desired. Once triggered, the basic pulse width may be extended by retriggering the gated active LOW going edge inputs (\bar{A}_1, \bar{A}_2) or the active HIGH going edge inputs (B_1, B_2), or be reduced by use of the overriding active LOW Reset.

To use the internal timing resistor of the "122" connect R_{int} to V_{CC} . For improved pulse width accuracy and repeatability, connect an external resistor between R_{ext}/C_{ext} and V_{CC} with R_{int} left open. To obtain variable pulse widths, connect an external variable resistance between R_{int} or R_{ext}/C_{ext} and V_{CC} .

DC CHARACTERISTICS OVER OPERATING TEMPERATURE RANGE^(b)

PARAMETER	TEST CONDITIONS	54/74		54S/74S		54LS/74LS		UNIT
		Min	Max	Min	Max	Min	Max	
I_{OS} Output short circuit current	$V_{CC} = \text{Max}$	-10	-40					mA
I_{CC} Supply current	$V_{CC} = \text{Max}$		28					mA

AC CHARACTERISTICS: $T_A = 25^\circ\text{C}$ (See Section 4 for Test Circuits and Conditions)

PARAMETER	TEST CONDITIONS	54/74		54S/74S		54LS/74LS		UNIT
		$C_L = 15\text{pF}$ $R_L = 400\Omega$						
		Min	Max	Min	Max	Min	Max	
t_{PLH} Propagation delay t_{PHL} \bar{A} input to Q & \bar{Q} output	Figure 1 $C_{ext} = 0\text{pF}, R_{ext} = 5\text{k}\Omega$		33 40					ns ns
t_{PLH} Propagation delay B t_{PHL} input to Q & \bar{Q} output	Figure 2 $C_{ext} = 0\text{pF}, R_{ext} = 5\text{k}\Omega$		28 36					ns ns
t_{PLH} Propagation delay \bar{R}_D t_{PHL} input to \bar{Q} & Q output	Figure 3 $C_{ext} = 0\text{pF}, R_{ext} = 5\text{k}\Omega$		40 27					ns ns
t_{WQ} Minimum Q pulse width	Figures 1 & 2 $C_{ext} = 0\text{pF}, R_{ext} = 5\text{k}\Omega$		65					ns
t_{WQ} Output pulse width	Figures 1 & 2 $C_{ext} = 1000\text{pF}, R_{ext} = 10\text{k}\Omega$	3.08	3.76					μs

NOTES

b. For family dc characteristics, see inside front cover for 54/74 and 54H/74H, and see inside back cover for 54S/74S and 54LS/74LS specifications.

AC SETUP REQUIREMENTS: $T_A = 25^\circ\text{C}$ (See Section 4 for Test Circuits and Conditions)

PARAMETER	TEST CONDITIONS	54/74		54S/74S		54LS/74LS		UNIT
		Min	Max	Min	Max	Min	Max	
t_{W} Minimum input pulse width to trigger	Figures 1 & 2	40						ns
R_{ext} External timing resistor range	Mil	5.0	25					$k\Omega$
	Com	5.0	50					$k\Omega$
C_{ext} External timing capacitance range				NO RESTRICTION				pF
C_{R_x/C_x} Stray capacitance to GND at R_{ext}/C_{ext} terminal			50					pF

AC WAVEFORMS

