

**PRELIMINARY**

# EB-CCD

**TV SCAN RATE TYPE : N7640**

**SLOW SCAN TYPE : N7220**

**For Low-Light-Level Imaging with high S/N ratio**

## IMAGING COMPARISON

Using Resolution Test Chart

Commercial 2/3-inch CCD



EB-CCD N7640

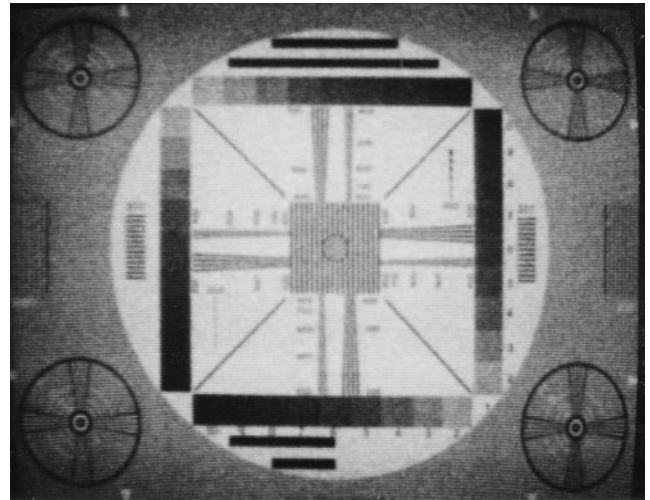

### ■ Imaging Conditions

Object illuminance: 0.1 lx

Lens: FUJINON-TV Zoom Lens/H6x 12.5R :F1.2/f2

## OVERVIEW

The EB-CCD is an absolutely new high-sensitivity imaging device that employs the "Electron Bombardment (EB)" effect for image intensification. The EB-CCD basically consists of a photocathode and a CCD chip arranged in parallel in a vacuum tube. An optical image is converted at the photocathode into an electron image, which is then accelerated and directly bombards the CCD surface to produce electron multiplication. Even a low-light-level image can be brought into view with a high S/N ratio.

Two types of EB-CCD are available depending on the readout method: the N7640 designed to operate at the TV scan rate and the N7220 for slow scan readout. Both types are compact and simple in structure, and deliver high sensitivity yet ensure high S/N ratio. The EB-CCD will open up new applications as the next generation of low-light-level imaging devices.

## SENSITIVITY COMPARISON

(Calculated data)

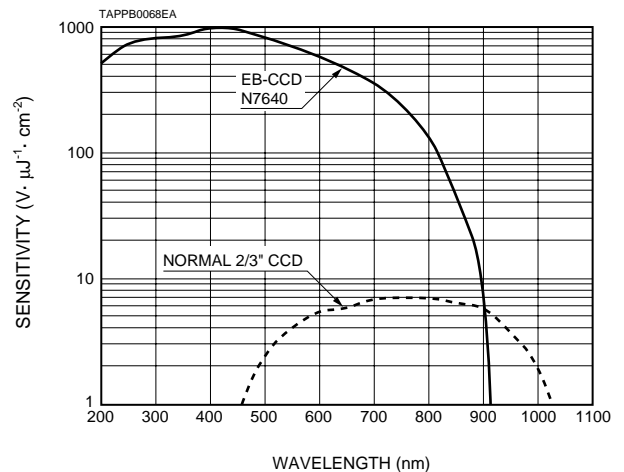

**HAMAMATSU**

# APPLICATIONS

## ● High sensitivity video camera

- Semiconductor wafer inspection
- Real time fluorescence observation
- Biochemical emission imaging
- Biophoton imaging

# FEATURES

## TV scan rate type

- Resolution 400 TV lines
- Gain 700
- Detection limit <sup>\*1</sup> 0.3 mlx

## Slow scan type

- Resolution 450 TV lines
- Gain 1300
- Detection limit Detectable down to single photon region

\*1: Minimum illuminance on the photocathode required to produce an image.

# SPECTRAL RESPONSE

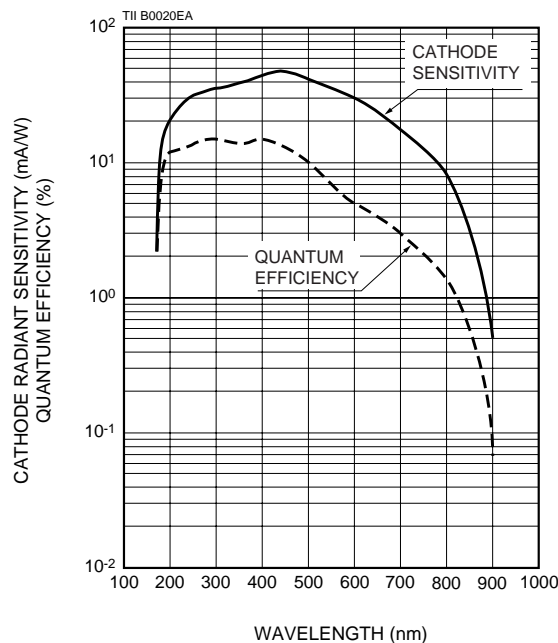

# SPECIFICATIONS

## ● EB-CCD

Parameter	N7640	N7220	Unit
Focusing Method	Proximity-focused		-
Window Material	Synthetic silica		-
Photocathode	Multialkali		-
Maximum Supply Voltage	-6	-8	kV
Gain (Typ.) <sup>*2</sup>	700	1300	-
Limiting Resolution (Typ.)	400	450	TV lines
Effective Area (HXV)	9.2 X 6.8	12.2 X 12.2	mm
Casing Material	Poly Oxy Methylene (POM)		-
Lead Wire Sheath	Teflon		-
Dimension	φ53 X 16.5 (excluding lead pins)		mm

\*2: N7640 at -6 kV, N7220 at -8 kV

## ● Internal CCD

Parameter	N7640	N7220	Unit
Drive Method	Frame transfer	Full frame transfer	-
CCD Format	2/3 inch format	1 inch format	-
Pixel Size	14 X 14	24 X 24	mm
Number of Effective Pixels (HXV)	658 X 490	512 X 512	-
Saturation Charge	65 X 10 <sup>3</sup>	200 X 10 <sup>3</sup>	electrons
Dark Current	<sup>*3</sup> 80 e <sup>-</sup> / (pixel-frame)	<sup>*4</sup> 300 e <sup>-</sup> / (pixel-s)	-
Readout Noise <sup>*5</sup>	100	50	e <sup>-</sup> RMS
CCD Readout Frequency	14	1	MHz
Vertical Clock	2 phases	2 phases	-
Horizontal Clock	2 phases	2 phases	-
Output	MOSFET source follower, two stages with load	MOSFET source follower, one stage	-

\*3: At 25 °C, MPP (Multi-Pinned Phase) operation, 33 ms/frame

\*5: N7640 at 12 MHz, N7220 at 150 kHz

\*4: At 0 °C, MPP (Multi-Pinned Phase) operation

## ● Ratings

Parameter	Min.	Max.	Unit
Operating Temperature Range	-30	+40	°C
Storage Temperature Range	-40	+40	°C

# PHOTON COUNTING IMAGING EXAMPLE

Slow Scan Type N7220

Object Illuminance  
**0.00002 lx**

Exposure Time: 0.02 s

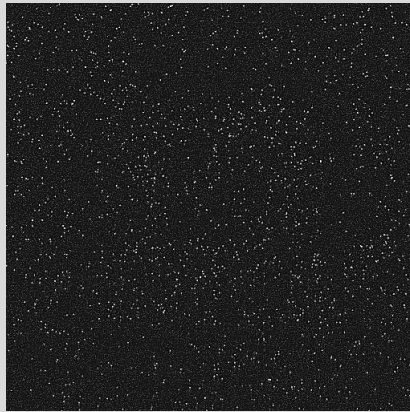

Exposure Time: 20 s

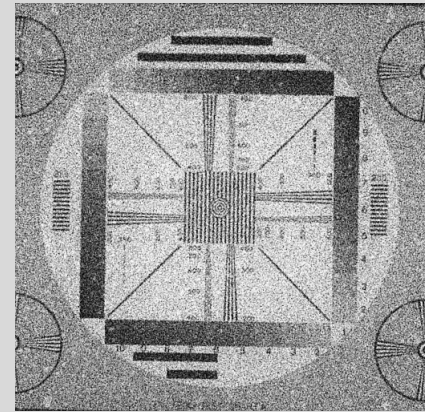

(Resolution 450 TV lines)

## ●Conditions

Light source	Tungsten lamp
Object illuminance	$2 \times 10^{-5}$ lx
Lens F value	5.6
Supply voltage	-8 kV
Ambient temperature	-25 °C

## DIMENSIONAL OUTLINES (Unit: mm)

### TV Rate Type (Frame Transfer CCD) N7640

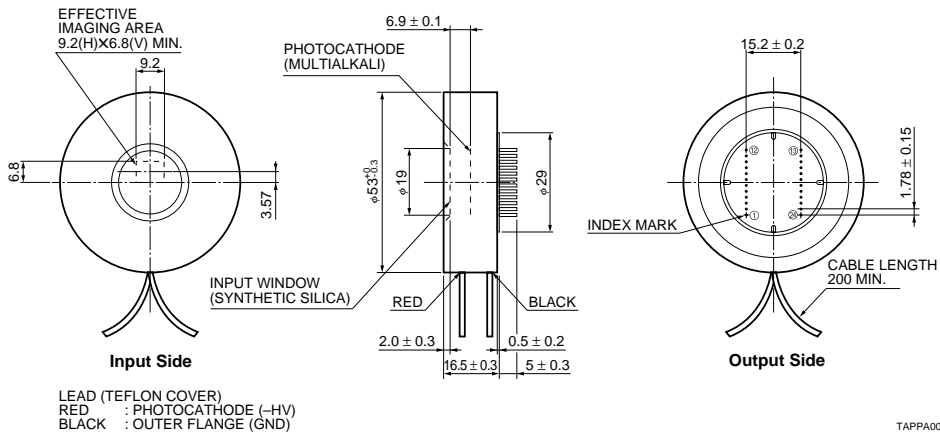

### Slow Scan Type (Full Frame Transfer CCD) N7220

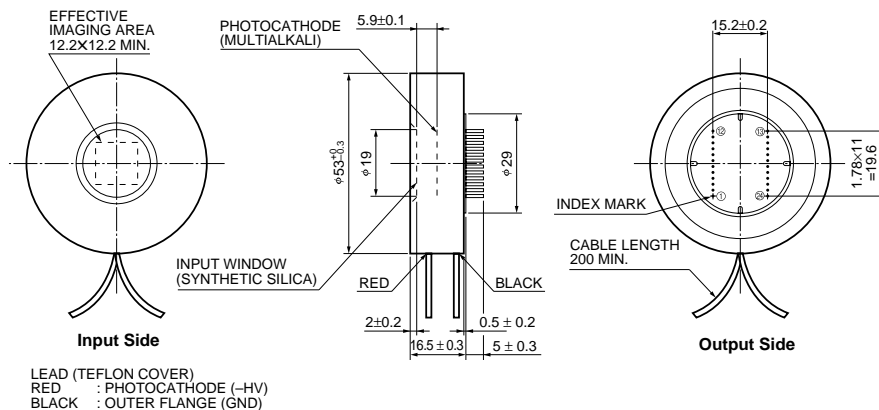

# EB-CCD CAMERA C8080

The C8080 is an EB-CCD camera incorporating a TV scan type EB-CCD (N7640). The C8080 is designed for simple use and functions, yet capable of imaging at very low light levels. Hamamatsu also provides the C8081 power supply ideal for use with the C8080 EB-CCD camera.

## ● SPECIFICATIONS

Parameter	Specifications	Unit
EB-CCD	EB-CCD (N7640)	-
Image Sensor	Frame transfer CCD	-
Spectral Response	185 to 900	nm
Gain	200 to 700	-
Effective Area	8.58 X 6.86 (2/3 inch format)	mm
Number of Effective Pixels (H X V)	640 X 480	-
Pixel Size	14 X 14	μm
Saturation Charge	130 000	electrons
Frame Rate	60 Hz interlace	-
Image Output Method	RS-170 (EIA)	-
Operating Temperature Range	0 to +40	°C
Storage Temperature Range	-10 to +40	°C
Humidity Range	Below 90 (no condensation)	%
Input Voltage (Input Current)	+15 (500 mA), -15 (500 mA), +5 (500 mA)	V
Dimension (W X H X D)	90 X 75 X 160	mm
Weight	Approx. 1.4	kg

## ● DEDICATED POWER SUPPLY C8081 (Option)

Parameter	Specifications	Unit
Input Voltage	85 to 135 (50 Hz, 60 Hz)	V ac
Maximum Power Consumption	90	VA
Dimension (W X H X D)	161 X 44 X 213	mm
Weight	Approx. 1.2	kg

## DIMENSIONAL OUTLINES (Unit: mm)

### ● C8080

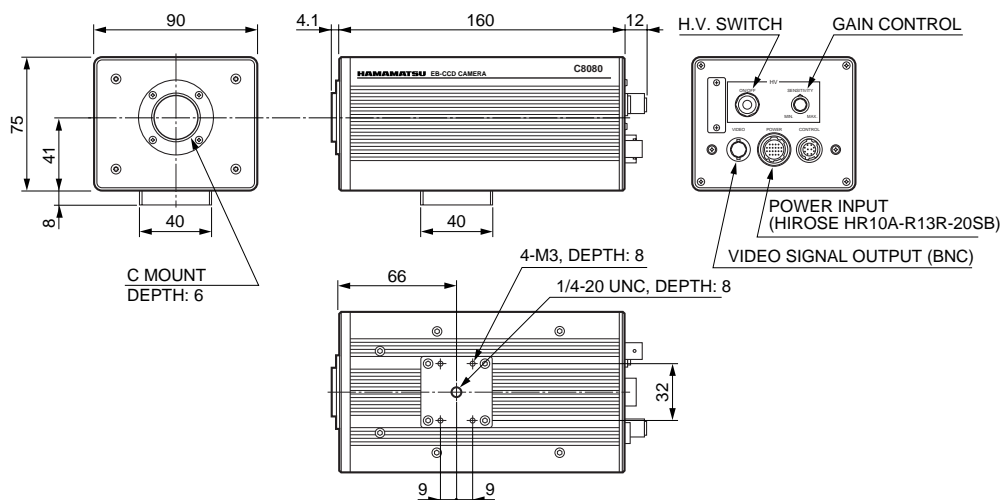

TAPPA0041EA

Subject to local technical requirements and regulations, availability of products in this promotional material may vary. Please consult with our sales office. Information furnished by HAMAMATSU is believed to be reliable. However, no responsibility is assumed for possible inaccuracies and omissions. Specifications are subject to change without notice. No patent rights are granted to any of the circuits described herein. © 2000 Hamamatsu Photonics K.K.

# HAMAMATSU

HOME PAGE URL <http://www.hamamatsu.com>

HAMAMATSU PHOTONICS K.K., Electron Tube Center

314-5, Shimokanzo, Toyooka-village, Iwata-gun, Shizuoka-ken, 438-0193, Japan, Telephone: (81)539/62-5248, Fax: (81)539/62-2205

U.S.A.: Hamamatsu Corporation: 360 Foothill Road, P. O. Box 6910, Bridgewater, N.J. 08807-0910, U.S.A., Telephone: (1)908-231-0960, Fax: (1)908-231-1218 E-mail: [usa@hamamatsu.com](mailto:usa@hamamatsu.com)

Germany: Hamamatsu Photonics Deutschland GmbH: Arzbergerstr. 10, D-82211 Herrsching am Ammersee, Germany, Telephone: (49)8152-375-0, Fax: (49)8152-2658 E-mail: [info@hamamatsu.de](mailto:info@hamamatsu.de)

France: Hamamatsu Photonics France S.A.R.L.: 8, Rue du Saule Trapu, Parc du Moulin de Massy, 91882 Massy Cedex, France, Telephone: (33)1 69 53 71 00, Fax: (33)1 69 53 71 10 E-mail: [infos@hamamatsu.fr](mailto:infos@hamamatsu.fr)

United Kingdom: Hamamatsu Photonics UK Limited: 2 Howard Court, 10 Tewin Road Welwyn Garden City Hertfordshire AL7 1BW, United Kingdom, Telephone: 44-(0)1707-294888, Fax: 44(0)1707-325777 E-mail: [info@hamamatsu.co.uk](mailto:info@hamamatsu.co.uk)

North Europe: Hamamatsu Photonics Norden AB: Smidesvägen 12, SE-171-41 SOLNA, Sweden, Telephone: (46)8-509-031-00, Fax: (46)8-509-031-01 E-mail: [info@hamamatsu.se](mailto:info@hamamatsu.se)

Italy: Hamamatsu Photonics Italia: S.R.L.: Strada della Moia, 1/E, 20020 Arese, (Milano), Italy, Telephone: (39)02-935 81 733, Fax: (39)02-935 81 741 E-mail: [info@hamamatsu.it](mailto:info@hamamatsu.it)

TAPP1032E01  
OCT. 2000 (9910) IP  
Printed in Japan (1000)