



8-BIT MICROCONTROLLER

Table of Contents-

1	GENERAL DESCRIPTION	5
2	FEATURES	6
3	PARTS INFORMATION LIST	8
3.1	Lead Free (RoHS) Parts information list.....	8
4	PIN CONFIGURATION	9
5	PIN DESCRIPTION.....	10
6	MEMORY ORGANIZATION.....	12
6.1	Program Flash Memory	12
6.2	Data Flash Memory	12
6.3	Data Memory (accessed by MOVX)	12
6.4	Scratch-pad RAM and Register Map	12
6.5	Working Registers	15
6.6	Bit addressable Locations.....	15
6.7	Stack.....	15
7	SPECIAL FUNCTION REGISTERS	16
7.1	SFR Location Table	16
7.2	SFR Detail Bit Descriptions	20
8	INSTRUCTION.....	70
9	POWER MANAGEMENT.....	80
9.1	Idle Mode	80
9.2	Power Down Mode	80
10	RESET CONDITIONS.....	81
10.1	External Reset	81
10.2	Power-On Reset (POR)	81
10.3	Watchdog Timer Reset	81
10.4	Software Reset	81
10.5	Brownout Reset	81
10.6	Reset State	81
11	INTERRUPTS	83
11.1	Interrupt Sources	83
11.2	Priority Level Structure	85
11.3	Interrupt Response Time	87
12	NVM MEMORY	89
13	PROGRAMMABLE TIMERS/COUNTERS	90



13.1	TIMER/COUNTERS 0 & 1	90
13.2	Time-Base Selection	90
13.3	MODE 0	90
13.4	MODE 1	91
13.5	MODE 2	92
13.6	MODE 3	93
14	WATCHDOG TIMER	95
14.1	WATCHDOG CONTROL	96
14.2	CLOCK CONTROL of Watchdog	96
15	TIMER2/INPUT CAPTURE MODULES	98
15.1	Capture Mode	98
15.2	Compare Mode	106
15.3	Reload Mode	106
16	TIMER3	107
16.1	Timer/Counter Mode	108
16.2	Capture Mode	108
16.3	Compare Mode	109
16.4	Auto-reload Mode	110
17	SERIAL PORT (UART)	111
17.1	MODE 0	111
17.2	MODE 1	112
17.3	MODE 2	114
17.4	MODE 3	115
17.5	Framing Error Detection	116
17.6	Multiprocessor Communications	116
18	I2C SERIAL CONTROL	118
18.1	I2C Port	118
18.2	SFR for I2C Function	119
18.2.1	I2C Address Registers, I2ADDR	119
18.2.2	I2C Data Register, I2DAT	119
18.2.3	I2C Control Register, I2CON	120
18.2.4	I2C Status Register, I2STATUS	120
18.2.5	I2C Clock Baud Rate Bits, I2CLK	121
18.2.6	I2C Time-out Counter Register, I2TOC	121
18.3	Modes of Operation	121
18.3.1	Master Transmitter Mode	122
18.3.2	Master Receiver Mode	122
18.3.3	Slave Receiver Mode	122



	18.3.4	Slave Transmitter Mode	122
	18.4	Data Transfer Flow in Five Operating Modes	122
19		SERIAL PHERIPHERAL INTERFACE (SPI)	129
	19.1	General descriptions	129
	19.2	Block descriptions	129
	19.3	Functional descriptions	131
	19.3.1	Master mode	131
	19.3.2	Slave Mode	134
	19.3.3	Slave select	138
	19.3.4	Slave Select output enable	138
	19.3.5	SPI I/O pins mode	139
	19.3.6	Programmable serial clock's phase and polarity	140
	19.3.7	Receive double buffered data register	140
	19.3.8	LSB first enable	140
	19.3.9	Write Collision detection	141
	19.3.10	Transfer complete interrupt	141
	19.3.11	Mode Fault	141
20		TIMED ACCESS PROTECTION	144
21		KEYBOARD INTERRUPT (KBI)	146
22		I/O PORT CONFIGURATION	147
	22.1	Quasi-Bidirectional Output Configuration	147
	22.2	Open Drain Output Configuration	148
	22.3	Push-Pull Output Configuration	148
	22.4	Input Only Configuration	149
	22.5	SFR of I/O Port Configuration	149
23		OSCILLATOR	150
	23.1	On-Chip RC Oscillator Option	150
	23.2	External Clock Input Option	150
24		POWER MONITORING FUNCTION	151
	24.1	Power On Detect	151
	24.2	Brownout Detect	151
	24.3	SFR of Brown-out Detection	152
25		PULSE-WIDTH-MODULATED (PWM) OUTPUTS	153
	25.1	PWM Features	153
	25.2	PWM Operation	155
	25.2.1	PWM Operation Mode	156
	25.2.2	Edge aligned PWM (up-counter)	156
	25.2.3	Center Aligned PWM (up/down counter)	159
	25.3	PWM Brake Function	162
	25.4	PWM Output Driving Control	164

25.5	PWM modes	164
25.5.1	Independent mode.....	164
25.5.2	Complementary mode	165
25.5.3	Synchronous mode.....	165
25.5.4	Group mode	165
25.6	Polarity Control	166
25.7	PWM Mask Output.....	166
25.8	SFR of PWM Unit	170
26	ANALOG-TO-DIGITAL CONVERTER (ADC)	171
26.1	Operation of ADC	171
26.1.1	Normal Operation of ADC.....	171
26.1.2	ADC Start Synchronous with PWM	173
26.1.3	ADC Converting in Power-dwon and Idle Mode	173
26.2	ADC Resolution and Analog Supply:.....	173
26.3	ADC Continuous Mode	174
26.4	ADC Compare Function.....	174
27	OP AMPLIFIER	176
28	ANALOG COMPARATORS	177
29	ICP (IN-CIRCUIT PROGRAM) FLASH PROGRAM	178
30	CONFIG BITS	179
30.1	CONFIG0.....	179
30.2	CONFIG1	181
31	ELECTRICAL CHARACTERISTICS.....	183
31.1	Absolute Maximum Ratings	183
31.2	DC Electrical Characteristics	184
31.3	ADC Converter DC Electrical Characteristics.....	186
31.4	OP Amplifier Electrical Characteristics	187
31.5	Comparator Electrical Characteristics	188
31.6	AC Electrical Characteristics	189
31.6.1	External Clock Characteristics.....	189
31.6.2	Supplied Voltage-Frequency	189
31.6.3	Internal RC Oscillator Characteristics.....	189
31.6.4	Typical Crystal Application Circuits.....	190
32	PACKAGE DIMENSIONS	191
32.1	48L LQFP (7x7x1.4mm footprint 2.0mm)	191
33	REVISION HISTORY	192



1 GENERAL DESCRIPTION

N79E875 series are 8-bit Turbo 51 microcontrollers which have embedded Flash that can be programmed by ICP (In Circuit Program) or by writer. The instruction sets of the N79E875 series are fully compatible with the standard 8052. N79E875 series contain a **16K** bytes of main Flash EPROM; a **256** bytes of RAM; **256** bytes AUX-RAM; **128** bytes NVM Data Flash EPROM support; **two** 16-bit timer/counters; **one** 16-bit timer with 3 capture inputs; **one** 12-bit capture/compare/auto-reload timer; **8**-channel multiplexed 10-bit A/D converter; **8**-channel 12-bit PWM that includes 6-channel for 3 pairs complementary PWM; **three** serial ports that includes a SPI, an I2C and an enhanced full duplex serial port; **one** OP amplifier; **two** analog comparators; 3-level selectable Brownout detector. These peripherals are supported by **17** sources of four-level interrupt capability. To facilitate programming and verification, the Flash EPROM inside N79E875 series allow the program memory to be programmed and read electronically. Once the code is confirmed, the user can protect the code for security.

N79E875 series, built-in efficient PWM generator and Input capture/timer, are designed for motor control applications such as E-bike, inverters of DC/BLDC/AC induction/Stepping motor and home appliance, etc. The built-in rich functions and peripheral also suit to general application.

2 FEATURES

- Fully static design 8-bit Turbo 51 CMOS microcontroller;
 - $V_{DD} = 4.5V$ to $5.5V$ @40MHz
 - $V_{DD} = 3.0V$ to $5.5V$ @24MHz
 - $V_{DD} = 2.4V$ to $5.5V$ @8MHz
- Operating temperature range
 - N79E875A/N79E875RA series: $-40^{\circ}C$ ~ $85^{\circ}C$
- Flexible CPU clock source configurable by config-bit and software:
 - High speed external oscillator: Up to 40MHz Crystal and resonator (enabled by config-bit).
 - Internal oscillator: Nominal 22MHz/11MHz (selected by config-bit)
N79E875A series: 22MHz/11MHz with $\pm 25\%$ accuracy
N79E875RA series: 22.1184MHz/11.0592MHz with $\pm 2\%$ accuracy, at 3.3V/25°C
- On-chip Memory
 - 16K bytes of Application Program Flash memory, with ICP and External Writer programmable mode.
 - 128 bytes (8 pages x 16 bytes) Data Flash for customer data storage used and 10K writer cycles; Data Flash program/erase $V_{DD}=3.0V$ to $5.5V$
 - 256 bytes of on-chip scratch-pad RAM.
 - 256 bytes of auxiliary RAM, software-selectable, accessed by MOVX instruction.
- Maximum 36 I/O pins.
 - Four outputs mode and TTL/Schmitt trigger selectable Port.
- 17 interrupts source with four levels of priority.
- Four timer/counters.
 - Two 16-bit timer/counters
 - One 16-bit timer supports 3 capture inputs capability for hall sensor feedback.
 - One 12-bit timer supports 12-bit auto reload timer, capture and compare mode.
- Three serial ports
 - One enhanced full duplex UART port with framing error detection and automatic address recognition.
 - One SPI with master/slave capability.
 - One I2C with master/slave capability.
- Four independent 12-bit PWM duty control units with maximum 8 port pins:
 - Six PWM output channels with mask control for BLDC application.
 - Three pairs complementary PWM with programmable dead-time insertion
 - Independent polarity setting for each channel
 - Two brake/fault input pins



- Up to two channels PWM independent from paired PWM channels.
- One build-in OP amplifier.
- Eight-channel multiplexed with 10-bits A/D converter.
 - Support synchronized trigger with PWM period.
 - Support OP amplifier output conversion.
 - Support digital compare function.
- Two analog comparators with optional internal reference voltage input at negative end.
- Eight-keypad interrupt inputs.
- Built-in power management.
 - Idle mode
 - Power down mode
- LED drive capability (20mA) on all port pins.
- Config-bits selectable 3 levels(4.5V/3.8V/2.6V) Brown-Out voltage detect interrupt and reset.
- Independent Programmable Watchdog Timer.
- Program and Data Flash security protection.
- Development Tools:
 - JTAG ICE(In Circuit Emulation) tool
 - ICP(In Circuit Programming) writer
- Packages:
 - Lead Free (RoHS) LQFP 48: N79E875ALG series (-40°C ~85°C)
 - Lead Free (RoHS) LQFP 48: N79E875RALG series (-40°C ~85°C)

3 PARTS INFORMATION LIST

3.1 Lead Free (RoHS) Parts information list

Table 3-1 Lead Free (RoHS) Parts information list

PART NO.	PROGRAM FLASH EPROM	RAM	DATA FLASH EPROM	TEMP °C	INTERNAL RC OSC ¹	PACKAGE
N79E875ALG	16KB	256B+256B	128B	-40~85°C	22MHz ± 25%	LQFP-48
N79E875RALG	16KB	256B+256B	128B	-40~85°C	22.1184MHz ± 2%	LQFP-48

Note:

1. Factory calibration condition: $V_{DD}=3.3V$, $T_A = 25^{\circ}C$



4 PIN CONFIGURATION

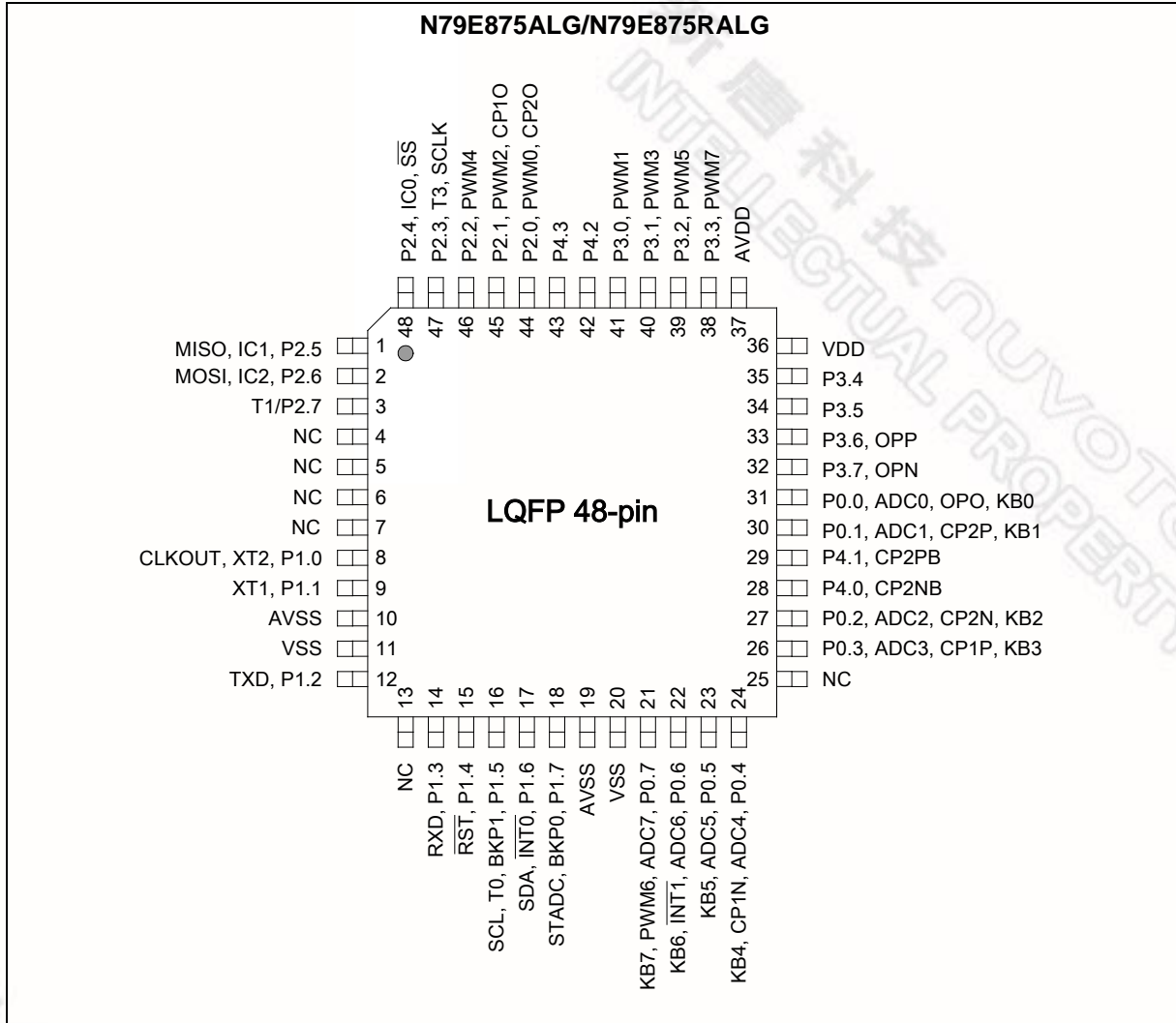



5 PIN DESCRIPTION

SYMBOL	Alternate Function 1	Alternate function 2	Alternate function 3	Type	DESCRIPTIONS
VDD				P	POWER SUPPLY: Supply voltage for operation.
VSS				P	GROUND: Ground potential.
AVDD				P	ANALOG Power Supply
AVSS				P	ANALOG GROUND.
P0.0	ADC0	OPO	KB0	I/O	Port0: Support 4 mode output and 2 mode input. Multifunction pins.
P0.1	ADC1	CP2PA	KB1	I/O	
P0.2	ADC2	CP2NA	KB2	I/O	
P0.3	ADC3	CP1P	KB3	I/O	
P0.4	ADC4	CP1N	KB4	I/O	
P0.5	ADC5		KB5	I/O	
P0.6	ADC6	/INT1	KB6	I/O	
P0.7	ADC7	PWM6	KB7	I/O	
P1.0	XT2	CLKOUT		I/O	Port1: Support 4 mode output and 2 mode input. Multifunction pins. P1.5 and P1.6 are permanently in Open-Drain type.
P1.1	XT1			I/O	
P1.2	TXD			I/O	
P1.3	RXD			I/O	
P1.4	/RST			I, H(rst)	
P1.5	T0	SCL	BKP1	D	
P1.6	/INT0	SDA		D	
P1.7		STADC	BKP0	I/O	
P2.0	PWM0	CP2O		I/O	Port2: Support 4 mode output and 2 mode input. Multifunction pins.
P2.1	PWM2	CP1O		I/O	
P2.2	PWM4			I/O	
P2.3	T3	SCLK		I/O	
P2.4	IC0	/SS		I/O	



SYMBOL	Alternate Function 1	Alternate function 2	Alternate function 3	Type	DESCRIPTIONS
P2.5	IC1	MISO		I/O	
P2.6	IC2	MOSI		I/O	
P2.7	T1			I/O	
P3.0	PWM1			I/O	Port3: Support 4 modes output and 2 modes input. Multifunction pins.
P3.1	PWM3			I/O	
P3.2	PWM5			I/O	
P3.3	PWM7			I/O	
P3.4				I/O	
P3.5				I/O	
P3.6	OPP			I/O	
P3.7	OPN			I/O	
P4.0		CP2NB		I/O	Support 4 modes output and 2 modes input.
P4.1		CP2PB		I/O	
P4.2				I/O	
P4.3				I/O	

TYPE: P: power, I: input, O: output, I/O: bi-directional with 4-type I/O modes,, H: Internal pull-up, L: Internal pull low, D: Open Drain

Notes:

- During Power-on-reset, all port pins are in tri-stated.
- After power-on-reset, all port pins state will follow CONFIG0.PRHI bit definition.
- All digital input pins support software enabled schmitt trigger buffer which is selected by SFR PORTS (ECH)

In application if MCU pins need external pull-up, it is recommended to add a pull-up resistor (10KΩ) between pin and power(V_{DD}) instead of directly wiring pin to V_{DD} for enhancing EMC.

6 MEMORY ORGANIZATION

N79E875 series separate the memory into two separate sections, the Program Memory and the Data Memory. The Program Memory is used to store the instruction op-codes, while the Data Memory is used to store data or for memory mapped devices.

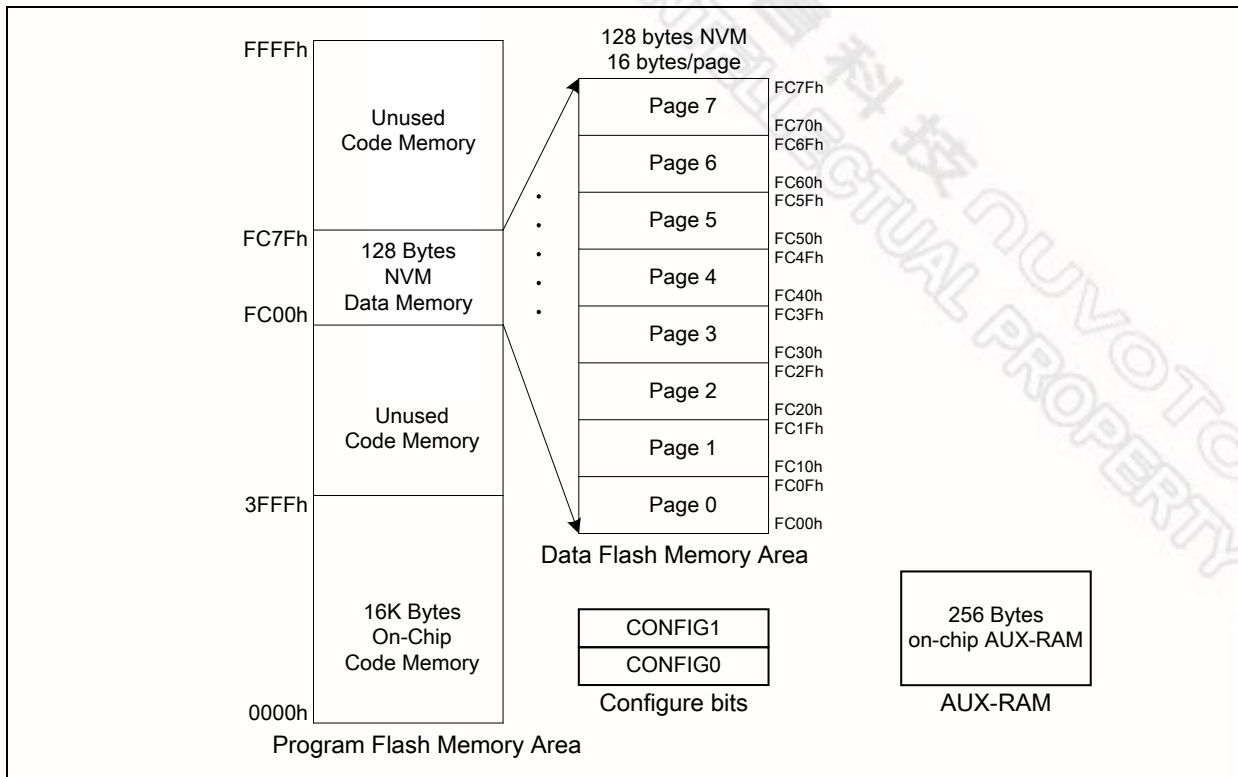

Figure 6-1 N79E875 series Memory Map

6.1 Program Flash Memory

The Program Memory on N79E875 series can be up to **16K** bytes long. All instructions are fetched for execution from this memory area. The MOVC instruction can also access this memory region.

6.2 Data Flash Memory

The NVM Data Memory of Flash EPROM on the N79E875 series is **128** bytes long, with page size of 16 bytes. The N79E875 series read the content of data memory by using “MOVC A, @A+DPTR”. To write data is by NVMADDRL, NVMDAT and NVMCON SFR's registers.

6.3 Data Memory (accessed by MOVX)

N79E875 provides 256 bytes AUX RAM accessed by the MOVX instruction. The data memory region is from 0000H to 00FFH. Figure 6-1 shows the memory map for this product series.

6.4 Scratch-pad RAM and Register Map

As mentioned before, N79E875 series have separate Program and Data Memory areas. The on-chip 256 bytes scratch pad RAM is in addition to the external memory. There are also several Special Function Registers (SFRs) which can be accessed by software. The SFRs can be accessed only by direct addressing, while the on-chip RAM can be accessed by either direct or indirect addressing.

FFH	Indirect RAM Addressing	SFR Direct Addressing Only
80H 7FH 00H	Direct & Indirect RAM Addressing	

Figure 6-2 N79E875 series RAM and SFR Memory Map

Since the scratch-pad RAM is only 256 bytes it can be used only when data contents are small. There are several other special purpose areas within the scratch-pad RAM. These are illustrated in next figure.

新唐科技 NUVOTON
INTELLECTUAL PROPERTY

FFH	Indirect RAM							
80H 7FH	Direct RAM							
30H 2FH	7F	7E	7D	7C	7B	7A	79	78
2EH	77	76	75	74	73	72	71	70
2DH	6F	6E	6D	6C	6B	6A	69	68
2CH	67	66	65	64	63	62	61	60
2BH	5F	5E	5D	5C	5B	5A	59	58
2AH	57	56	55	54	53	52	51	50
29H	4F	4E	4D	4C	4B	4A	49	48
28H	47	46	45	44	43	42	41	40
27H	3F	3E	3D	3C	3B	3A	39	38
26H	37	36	35	34	33	32	31	30
25H	2F	2E	2D	2C	2B	2A	29	28
24H	27	26	25	24	23	22	21	20
23H	1F	1E	1D	1C	1B	1A	19	18
22H	17	16	15	14	13	12	11	10
21H	0F	0E	0D	0C	0B	0A	09	08
20H	07	06	05	04	03	02	01	00
1FH	Bank 3							
18H 17H	Bank 2							
10H 0FH	Bank 1							
08H 07H	Bank 0							
00H								

Figure 6-3 Scratch-pad RAM



6.5 Working Registers

There are four sets of working registers, each consisting of eight 8-bit registers. These are termed as Banks 0, 1, 2, and 3. Individual registers within these banks can be directly accessed by separate instructions. These individual registers are named as R0, R1, R2, R3, R4, R5, R6 and R7. However, at any one time N79E875 series can work with only one particular bank. The bank selection is done by setting RS1-RS0 bits in the PSW. The R0 and R1 registers are used to store the address for indirect accessing.

6.6 Bit addressable Locations

The Scratch-pad RAM area from location 20h to 2Fh is byte as well as bit addressable. This means that a bit in this area can be individually addressed. In addition some of the SFRs are also bit addressable. The instruction decoder is able to distinguish a bit access from a byte access by the type of the instruction itself. In the SFR area, any existing SFR whose address ends in a 0 or 8 is bit addressable.

6.7 Stack

The scratch-pad RAM can be used for the stack. This area is selected by the Stack Pointer (SP), which stores the address of the top of the stack. Whenever a jump, call or interrupt is invoked the return address is placed on the stack. There is no restriction as to where the stack can begin in the RAM. By default however, the Stack Pointer contains 07h at reset. The user can then change this to any value desired. The SP will point to the last used value. Therefore, the SP will be incremented and then address saved onto the stack. Conversely, while popping from the stack the contents will be read first, and then the SP is decreased.

7 SPECIAL FUNCTION REGISTERS

N79E875 series use Special Function Registers (SFRs) to control and monitor peripherals and their Modes. The SFRs reside in the register locations 80-FFh and are accessed by direct addressing only. Some of the SFRs are bit addressable. This is very useful in cases where we wish to modify a particular bit without changing the others. The SFRs that are bit addressable are those whose addresses end in 0 or 8. N79E875 series contain all the SFRs present in the standard 8052. However some additional SFRs are added. In some cases the unused bits in the original 8052, have been given new functions. The list of the SFRs is as follows.

7.1 SFR Location Table

F8	IP1		P4M1	P4M2	PWMCON4	PWM6L	PWM6H	AUXR2
F0	B			SPCR	SPSR	SPDR	PADIDS	IP1H
E8	EIE1				PORTS	PME	PMD	IP2H
E0	ACC	ADCCON	ADCH	ADCCON1	CCL0	CCH0	CCL1	CCH1
D8	WDCON⁽³⁾	PWMPL	PWM0L		PWMCON1	PWM2L		PWMB
D0	PSW	PWMPH	PWM0H		EIE2	PWM2H		PWMCON3
C8	T2CON	T2MOD	RCAP2L	RCAP2H	TL2	TH2	NVMCON	NVMDAT
C0	I2CON	I2ADDR	T3CON	PNP			NVMADDRL	TA
B8	IP0	SADEN			I2DATA	I2STATUS	I2CLK	I2TIMER
B0	P3	P0M1	P0M2	P1M1	P1M2	P2M1	P2M2	IP0H
A8	IE	SADDR		DTCNT ⁽³⁾	CMP1	CMP2	PDTC0 ⁽³⁾	ADCDLY
A0	P2	KBI	AUXR1	CAPCON0	CAPCON1	P4	CCL2	CCH2
98	SCON	SBUF	IP2	PIO	ADCRL	ADCRH	P3M1	P3M2
90	P1	T3L	RCAP3L	RCAP3HT3H			PWM4L	PWM4H
88	TCON	TMOD	TL0	TL1	TH0	TH1	CKCON	
80	P0	SP	DPL	DPH			DIV	PCON

Table 7- 1 Special Function Register Location Table

Note:

1. The SFRs in the column with dark borders are bit-addressable
2. The table is condensed with eight locations per row. Empty locations indicate that these are no registers at these addresses.
3. With Timed Access Protection on write operation.

Preliminary N79E875 Data Sheet



SYMBOL	DEFINITION	ADDRESS	MSB								LSB	RESET
			BIT ADDRESS, SYMBOL									
AUXR2	AUXR2 CONTROL REGISTER	FFH	T1OE	T0OE	PCMP2DID S.1	PCMP2DID S.0	POPDIDS	ENCLK	ADC1SEL	ENOP	0000 0000b	
PWM6H	PWM 6 HIGH BITS REGISTER	FEH	-	-	-	-	PWM6.11	WM6.10	PWM6.9	PWM6.8	XXXX 0000b	
PWM6L	PWM 6 LOW BITS REGISTER	FDH	PWM6.7	PWM6.6	PWM6.5	PWM6.4	PWM6.3	PWM6.2	PWM6.1	PWM6.0	0000 0000b	
PWMCON4	PWM CONTROL REGISTER 4	FCH	BK1FILT.1	BK1FILT.0	BK0FILT.1	BK0FILT.0	AUTOBK 1	-	BKEN1	BKEN0	0000 0X00b	
P4M2	PORT 4 OUTPUT MODE 2	FBH	-	-	-	-	P4M2.3	P4M2.2	P4M2.1	P4M2.0	XXXX 0000b	
P4M1	PORT 4 OUTPUT MODE 1	FAH	-	-	-	-	P4M1.3	P4M1.2	P4M1.1	P4M1.0	XXXX 0000b	
IP1	INTERRUPT PRIORITY 1	F8H	(FF) PCAP	(FE) PPWM	(FD) PBRK	(FC) PWDI	(FB) -	(FA) PCI	(F9) PKB	(F8) PI2	0000 X000b	
IP1H	INTERRUPT HIGH PRIORITY 1	F7H	PCAPH	PPWMH	PBRKH	PWDIH	-	PCIH	PKBH	PI2H	0000 X000b	
PADIDS	PORT ADC DIGITAL INPUTS DISABLE	F6H	PADIDS.7	PADIDS.6	PADIDS.5	PADIDS.4	PADIDS.3	PADIDS.2	PADIDS.1	PADIDS.0	0000 0000b	
SPDR	SERIAL PERIPHERAL DATA REGISTER	F5H	SPD.7	SPD.6	SPD.5	SPD.4	SPD.3	SPD.2	SPD.1	SPD.0	XXXX XXXXb	
SPSR	SERIAL PERIPHERAL STATUS REGISTER	F4H	SPIF	WCOL	SPIOVF	MODF	DRSS	-	-	-	0000 0XXXb	
SPCR	SERIAL PERIPHERAL CONTROL REGISTER	F3H	SSOE	SPE	LSBFE	MSTR	CPOL	CPHA	SPR1	SPR0	0000 0100b	
PCH	PC COUNTER HIGH REGISTER	F2H	-	-	-	-	-	-	-	-	0000 0000b	
PCL	PC COUNTER LOW REGISTER	F1H	-	-	-	-	-	-	-	-	0000 0000b	
B	B REGISTER	F0H	(F7)	(F6)	(F5)	(F4)	(F3)	(F2)	(F1)	(F0)	0000 0000b	
IP2H	INTERRUPT HIGH PRIORITY 2	EFH	-	PT2H	-	-	PSPIH	-	-	PET3H	X0XX 0XX0b	
PMD	PWM MASK DATA REGISTER	EEH	-	-	PMD.5	PMD.4	PMD.3	PMD.2	PMD.1	PMD.0	XX00 0000b	
PME	PWM MASK ENABLE REGISTER	EDH	-	-	PME.5	PME.4	PME.3	PME.2	PME.1	PME.0	XX00 0000b	
PORTS	PORT SHMITT REGISTER	ECH	-	-	-	P4S	P3S	P2S	P1S	P0S	XXX0 0000b	
EIE1	INTERRUPT ENABLE 1	E8H	(EF) ECPTF	(EE) EPWM	(ED) EBRK	(EC) EWDI	(EB) -	(EA) ECI	(E9) EKB	(E8) EI2C	0000 X000b	
CCH1	INPUT CAPTURE 1 HIGH	E7H	CCH1.7	CCH1.6	CCH1.5	CCH1.4	CCH1.3	CCH1.2	CCH1.1	CCH1.0	0000 0000b	
CCL1	INPUT CAPTURE 1 LOW	E6H	CCL1.7	CCL1.6	CCL1.5	CCL1.4	CCL1.3	CCL1.2	CCL1.1	CCL1.0	0000 0000b	
CCH0	INPUT CAPTURE 0 HIGH	E5H	CCH0.7	CCH0.6	CCH0.5	CCH0.4	CCH0.3	CCH0.2	CCH0.1	CCH0.0	0000 0000b	
CCL0	INPUT CAPTURE 0 LOW	E4H	CCL0.7	CCL0.6	CCL0.5	CCL0.4	CCL0.3	CCL0.2	CCL0.1	CCL0.0	0000 0000b	
ADCCON1	ADC CONTROL REGISTER 1	E3H	ADCLK.1	ADCLK.0	STADCT.1	STADCT.0	DLYDIV	ADCCM	PWMSRC .1	PWMSRC .0	0000 0000b	
ADCH	ADC CONVERTER RESULT	E2H	ADC.9	ADC.8	ADC.7	ADC.6	ADC.5	ADC.4	ADC.3	ADC.2	XXXX XXXXb	
ADCCON	ADC CONTROL REGISTER	E1H	ADC.1	ADC.0	ADCEX	ADCI	ADCS	AADR2	AADR1	AADR0	XX00 0000b	
ACC	ACCUMULATOR	E0H	(E7)	(E6)	(E5)	(E4)	(E3)	(E2)	(E1)	(E0)	0000 0000b	
PWMB	PWM BRAKE OUTPUT	DFH	-	-	PWM5B	PWM4B	PWM3B	PWM2B	PWM1B	PWM0B	XX00 0000b	
PWM2L	PWM 2 LOW BITS REGISTER	DDH	PWM2.7	PWM2.6	PWM2.5	PWM2.4	PWM2.3	PWM2.2	PWM2.1	PWM2.0	0000 0000b	
PWMCON1	PWM CONTROL REGISTER 1	DCH	PWMRUN	LOAD	PWMF	CLRPWM	FBK1	FBK0	PMOD.1	PMOD.0	0000 0000b	
PWM0L	PWM 0 LOW BITS REGISTER	DAH	PWM0.7	PWM0.6	PWM0.5	PWM0.4	PWM0.3	PWM0.2	PWM0.1	PWM0.0	0000 0000b	
PWMPL	PWM COUNTER LOW REGISTER	D9H	PWMP0.7	PWMP0.6	PWMP0.5	PWMP0.4	PWMP0.3	PWMP0.2	PWMP0.1	PWMP0.0	0000 0000b	
WDCON	WATCH-DOG CONTROL	D8H	(DF) WDRUN	(DE) -	(DD) WD1	(DC) WDO	(DB) WDIF	(DA) WTRF	(D9) EWRST	(D8) WDCLR	EXTERNAL RESET: 0X00 0X00b WATCHDOG RESET: 0X000100b POWER ON RESET 0X00 0000b	
PWMCON3	PWM CONTROL REGISTER 3	D7H	HZ_Even	HZ_Odd	GRP	PWMTYPE	-	-	P6CTRL	INT_TYP E	XX00 XX00b	
PWM2H	PWM 2 HIGH BITS REGISTER	D5H	-	-	-	-	PWM2.11	PWM2.10	PWM2.9	PWM2.8	XXXX 0000b	

Preliminary N79E875 Data Sheet



SYMBOL	DEFINITION	ADDRESS	MSB								BIT ADDRESS, SYMBOL				LSB	RESET
EIE2	INTERRUPT ENABLE 2	D4H	-	ET2	-	-	-	ESPI	-	EADCP	ET3	X0XX 0X00b				
PWM0H	PWM 0 HIGH BITS REGISTER	D2H	-	-	-	-	PWM0.11	PWM0.10	PWM0.9	PWM0.8	XXXX 0000b					
PWMPH	PWM COUNTER HIGH REGISTER	D1H	-	-	-	-	PWMP.11	PWMP.10	PWMP.9	PWMP.8	XXXX 0000b					
PSW	PROGRAM STATUS WORD	D0H	(D7) CY	(D6) AC	(D5) F0	(D4) RS1	(D3) RS0	(D2) OV	(D1) F1	(D0) P	0000 0000b					
NVMDATA	NVM DATA	CFH	NVMDATA.7	NVMDATA.6	NVMDATA.5	NVMDATA.4	NVMDAT.A.3	NVMDAT.A.2	NVMDAT.A.1	NVMDAT.A.0	0000 0000b					
NVMCON	NVM CONTROL	CEH	EER	EWR	-	-	-	-	-	-	00XX XXXXb					
TH2	TIMER 2 MSB	CDH	TH2.7	TH2.6	TH2.5	TH2.4	TH2.3	TH2.2	TH2.1	TH2.0	0000 0000b					
TL2	TIMER 2 LSB	CCH	TL2.7	TL2.6	TL2.5	TL2.4	TL2.3	TL2.2	TL2.1	TL2.0	0000 0000b					
RCAP2H	TIMER 2 RELOAD MSB	CBH	RCAP2H.7	RCAP2H.6	RCAP2H.5	RCAP2H.4	RCAP2H.3	RCAP2H.2	RCAP2H.1	RCAP2H.0	0000 0000b					
RCAP2L	TIMER 2 RELOAD LSB	CAH	RCAP2L.7	RCAP2L.6	RCAP2L.5	RCAP2L.4	RCAP2L.3	RCAP2L.2	RCAP2L.1	RCAP2L.0	0000 0000b					
T2MOD	TIMER 2 MODE	C9H	ENLD	ICEN2	ICEN1	ICEN0	T2CR	CMPCR	-	-	0000 00XXb					
T2CON	TIMER 2 CONTROL	C8H	TF2	-	-	-	-	TR2	-	CMP/RL2	0XXX X0X0b					
TA	TIMED ACCESS PROTECTION	C7H	TA.7	TA.6	TA.5	TA.4	TA.3	TA.2	TA.1	TA.0	0000 0000b					
NVMADDRL	NVM LOW BYTE ADDRESS	C6H	NVMADDR.7	NVMADDR.6	NVMADDR.5	NVMADDR.4	NVMADDR.3	NVMADDR.2	NVMADDR.1	NVMADDR.0	0000 0000b					
NVMADDRH	NVM HIGH BYTE ADDRESS	C5H	-	-	-	-	-	-	-	NVMADDR.8	XXXX XXX0b					
PNP	PWM NEGATIVE POLARITY	C3H	-	-	PNP.5	PNP.4	PNP.3	PNP.2	PNP.1	PNP.0	XX00 0000b					
T3CON	TIMER 3 CONTROL	C2H	TF3	EXF3	T3CNTE	T3OE	T3RST	TR3	T3MOD.1	T3MOD.0	0000 0000b					
I2ADDR	I2C ADDRESS1	C1H	ADDR.7	ADDR.6	ADDR.5	ADDR.4	ADDR.3	ADDR.2	ADDR.1	GC	XXXX XXX0b					
I2CON	I2C CONTROL REGISTER	C0H	(C7) -	(C6) ENSI	(C5) STA	(C4) STO	(C3) SI	(C2) AA	(C1) -	(C0) -	X00000XXb					
I2TOC	I2C TIMER-OUT COUNTER REGISTER	BFH	-	-	-	-	-	ENTI	DIV4	TIF	XXXX X000b					
I2CLK	I2C CLOCK RATE	BEH	I2CLK.7	I2CLK.6	I2CLK.5	I2CLK.4	I2CLK.3	I2CLK.2	I2CLK.1	I2CLK.0	00000000b					
I2STATUS	I2C STATUS REGISTER	BDH	B7	B6	B5	B4	B3	B2	B1	B0	1111 1000b					
I2DAT	I2C DATA REGISTER	BCH	I2DAT.7	I2DAT.6	I2DAT.5	I2DAT.4	I2DAT.3	I2DAT.2	I2DAT.1	I2DAT.0	XXXX XXXXb					
SADEN	SLAVE ADDRESS MASK	B9H	SADEN.7	SADEN.6	SADEN.5	SADEN.4	SADEN.3	SADEN.2	SADEN.1	SADEN.0	0000 0000b					
IP0	INTERRUPT PRIORITY	B8H	(BF) -	(BE) PADC	(BD) PBO	(BC) PS	(BB) PT1	(BA) PX1	(B9) PT0	(B8) PX0	X000 0000b					
IP0H	INTERRUPT HIGH PRIORITY	B7H	-	PADCH	PBOH	PSH	PT1H	PX1H	PT0H	PX0H	X000 0000b					
P2M2	PORT 2 OUTPUT MODE 2	B6H	P2M2.7	P2M2.6	P2M2.5	P2M2.4	P2M2.3	P2M2.2	P2M2.1	P2M2.0	0000 0000b					
P2M1	PORT 2 OUTPUT MODE 1	B5H	P2M1.7	P2M1.6	P2M1.5	P2M1.4	P2M1.3	P2M1.2	P2M1.1	P2M1.0	0000 0000b					
P1M2	PORT 1 OUTPUT MODE 2	B4H	P1M2.7	-	-	-	P1M2.3	P1M2.2	P1M2.1	P1M2.0	000X 0000b					
P1M1	PORT 1 OUTPUT MODE 1	B3H	P1M1.7	-	-	-	P1M1.3	P1M1.2	P1M1.1	P1M1.0	000X 0000b					
P0M2	PORT 0 OUTPUT MODE 2	B2H	P0M2.7	P0M2.6	P0M2.5	P0M2.4	P0M2.3	P0M2.2	P0M2.1	P0M2.0	0000 0000b					
P0M1	PORT 0 OUTPUT MODE 1	B1H	P0M1.7	P0M1.6	P0M1.5	P0M1.4	P0M1.3	P0M1.2	P0M1.1	P0M1.0	0000 0000b					
P3	PORT 3	B0H	(B7) P3.7 OPN	(B6) P3.6 OPP	(B5) P3.5	(B4) P3.4	(B3) P3.3 PWM7	(B2) P3.2 PWM5	(B1) P3.1 PWM3	(B0) P3.0 PWM1	1111 1111b ⁽¹⁾ 0000 0000b					
ADCDLY	ADC DELAY START REGISTER	AFH	ADCDLY.7	ADCDLY.6	ADCDLY.5	ADCDLY.4	ADCDLY.3	ADCDLY.2	ADCDLY.1	ADCDLY.0	0000 0000b					
PDTC0	PWM DEAD TIME CONTROL 0 REGISTER	AEH	-	-	-	-	-	DTENB4	DTENB2	DTENB0	XXXX X000b					
CMP2	COMPARATOR 1 CONTROL REGISTER	ADH	-	HYSEN2	COMPEN2	CP2	CN2	COE2	CO2	CMF2	XX0X 0000b					
CMP1	COMPARATOR 1 CONTROL REGISTER	ACH	-	HYSEN1	COMPEN1	-	CN1	COE1	CO1	CMF1	XX0X 0000b					
DTCNT	PWM DEAD TIME COUNTER REGISTER	ABH	DTCNT.7	DTCNT.6	DTCNT.5	DTCNT.4	DTCNT.3	DTCNT.2	DTCNT.1	DTCNT.0	0000 0000b					
SADDR	SLAVE ADDRESS	A9H	SADDR.7	SADDR.6	SADDR.5	SADDR.4	SADDR.3	SADDR.2	SADDR.1	SADDR.0	0000 0000b					
IE	INTERRUPT ENABLE	A8H	(AF) EA	(AE) EADC	(AD) EBO	(AC) ES	(AB) ET1	(AA) EX1	(A9) ET0	(A8) EX0	0000 0000b					
CCH2	INPUT CAPTURE 2 HIGH	A7H	CCH2.7	CCH2.6	CCH2.5	CCH2.4	CCH2.3	CCH2.2	CCH2.1	CCH2.0	0000 0000b					

Preliminary N79E875 Data Sheet



SYMBOL	DEFINITION	ADDRESS	MSB								BIT ADDRESS, SYMBOL				LSB	RESET
CCL2	INPUT CAPTURE 2 LOW	A6H	CCL2.7	CCL2.6	CCL2.5	CCL2.4	CCL2.3	CCL2.2	CCL2.1	CCL2.0					0000 0000b	
P4	PORT 4	A5H	-	-	-	-	P4.3	P4.2	P4.1 CP2PB	P4.0 CP2NB					XXXX 1111b ⁽¹⁾ XXXX 0000b	
CAPCON1	CAPTURE CONTROL 1	A4H	-	IC0SS	ENF2	ENF1	ENF0	CPTF2	CPTF1	CPTF0					X000 0000b	
CAPCON0	CAPTURE CONTROL 0	A3H	CCT2.1	CCT2.0	CCT1.1	CCT1.0	CCT0.1	CCT0.0	CCLD.1	CCLD.0					0000 0000b	
AUXR1	AUX FUNCTION REGISTER 1	A2H	KBF	BOD	BOI	LPBOD	SRST	ADCEN	RCCLK	BOS					0X00 0000b	
KBI	KEYBOARD INTERRUPT	A1H	KBI.7	KBI.6	KBI.5	KBI.4	KBI.3	KBI.2	KBI.1	KBI.0					0000 0000b	
P2	PORT 2	A0H	(A7) P2.7 T1	(A6) P2.6 IC2 MOSI	(A5) P2.5 IC1 MISO	(A4) P2.4 IC0 /SS	(A3) P2.3 T3 SCLK	(A2) P2.2 PWM4	(A1) P2.1 PWM2 CP1O	(A0) P2.0 PWM0 CP2O					1111 1111b ⁽¹⁾ 0000 0000b	
P3M2	PORT 3 OUTPUT MODE 2	9FH	P3M2.7	P3M2.6	P3M2.5	P3M2.4	P3M2.3	P3M2.2	P3M2.1	P3M2.0					0000 0000b	
P3M1	PORT 3 OUTPUT MODE 1	9EH	P3M1.7	P3M1.6	P3M1.5	P3M1.4	P3M1.3	P3M1.2	P3M1.1	P3M1.0					0000 0000b	
ADCRH	ADC COMPARE REFERENCE HIGH DATA REGISTER	9DH	ADCR.9	ADCR.8	ADCR.7	ADCR.6	ADCR.5	ADCR.4	ADCR.3	ADCR.2					XXXX XXXXb	
ADCRL	ADC COMPARE REFERENCE LOW DATA/COMPARE REGISTER	9CH	ADCR.1	ADCR.0	ADCP0	ADCP1	-	-	T3CSS	ENADCP					XX10 XX00b	
PIO	PWM IO REGISTER	9BH	PIO.7	PIO.6	PIO.5	PIO.4	PIO.3	PIO.2	PIO.1	PIO.0					0000 0000b	
IP2	INTERRUPT PRIORITY 2	9AH	-	PT2	-	-	PSPI	-	-	PET3					X0XX 0XX0b	
SBUF	SERIAL BUFFER	99H	SBUF.7	SBUF.6	SBUF.5	SBUF.4	SBUF.3	SBUF.2	SBUF.1	SBUF.0					XXXX XXXXb	
SCON	SERIAL CONTROL	98H	(9F) SMO/FE	(9E) SM1	(9D) SM2	(9C) REN	(9B) TB8	(9A) RB8	(99) TI	(98) RI					0000 0000b	
PWM4H	PWM 4 HIGH BITS REGISTER	97H	-	-	-	-	PWM4.11	PWM4.10	PWM4.9	PWM4.8					XXXX 0000b	
PWM4L	PWM 4 LOW BITS REGISTER	96H	PWM4.7	PWM4.6	PWM4.5	PWM4.4	PWM4.3	PWM4.2	PWM4.1	PWM4.0					0000 0000b	
RCAP3HT3H	TIMER 3 RELOAD MSB	93H	RCAP3.11	RCAP3.10	RCAP3.9	RCAP3.8	T3.11	T3.10	T3.9	T3.8					0000 0000b	
RCAP3L	TIMER 3 RELOAD LSB	92H	RCAP3.7	RCAP3.6	RCAP3.5	RCAP3.4	RCAP3.3	RCAP3.2	RCAP3.1	RCAP3.0					0000 0000b	
TL3	TIMER 3 LSB	91H	T3.7	T3.6	T3.5	T3.4	T3.3	T3.2	T3.1	T3.0					0000 0000b	
P1	PORT 1	90H	(97) P1.7 STADC BKP0	(96) P1.6 /INT0 SDA	(95) P1.5 T0 SCL BKP1	(94) P1.4 /RST	(93) P1.3 RXD	(92) P1.2 TXD	(91) P1.1 XT1	(90) P1.0 XT2 CLKOUT					1111 1111b ⁽¹⁾ 0000 0000b	
CKCON	CLOCK CONTROL	8EH	-	-	-	T1M	T0M	-	-	-					XXX0 0XXXb	
TH1	TIMER HIGH 1	8DH	TH1.7	TH1.6	TH1.5	TH1.4	TH1.3	TH1.2	TH1.1	TH1.0					0000 0000b	
TH0	TIMER HIGH 0	8CH	TH0.7	TH0.6	TH0.5	TH0.4	TH0.3	TH0.2	TH0.1	TH0.0					0000 0000b	
TL1	TIMER LOW 1	8BH	TL1.7	TL1.6	TL1.5	TL1.4	TL1.3	TL1.2	TL1.1	TL1.0					0000 0000b	
TL0	TIMER LOW 0	8AH	TL0.7	TL0.6	TL0.5	TL0.4	TL0.3	TL0.2	TL0.1	TL0.0					0000 0000b	
TMOD	TIMER MODE	89H	GATE	C/T	M1	M0	GATE	C/T	M1	M0					0000 0000b	
TCON	TIMER CONTROL	88H	(8F) TF1	(8E) TR1	(8D) TF0	(8C) TR0	(8B) IE1	(8A) IT1	(89) IE0	(88) IT0					0000 0000b	
PCON	POWER CONTROL	87H	SMOD	SMOD0	BOF	POR	GF1	GF0	PD	IDL					00XX 0000b	
DIV	DIVIDER	86H	CCDIV.1	CCDIV.0	PWMDIV.1	PWMDIV.0	T3DIV.1	T3DIV.0	TODIV.1	TODIV.0					0000 0000b	
DPH	DATA POINTER HIGH	83H	DPH.7	DPH.6	DPH.5	DPH.4	DPH.3	DPH.2	DPH.1	DPH.0					0000 0000b	
DPL	DATA POINTER LOW	82H	DPL.7	DPL.6	DPL.5	DPL.4	DPL.3	DPL.2	DPL.1	DPL.0					0000 0000b	
SP	STACK POINTER	81H	SP.7	SP.6	SP.5	SP.4	SP.3	SP.2	SP.1	SP.0					0000 0111b	
P0	PORT 0	80H	(87) P0.7 ADC7 PWM6 KB7	(86) P0.6 ADC6 /INT1 KB6	(85) P0.5 ADC5 KB5	(84) P0.4 ADC4 CP1N KB4	(83) P0.3 ADC3 CP1P KB3	(82) P0.2 ADC2 CP2NA KB2	(81) P0.1 ADC1 CP2PA KB1	(80) P0.0 ADC0 OPO KB0					1111 1111b ⁽¹⁾ 0000 0000b	

Note: 1. If config0.PRHI=1, the initial value is FFh at reset. If config0.PRHI=0, the initial value is 00h at reset



7.2 SFR Detail Bit Descriptions

PORT 0

Initial=1111_1111b/0000_0000b

Bit: 7 6 5 4 3 2 1 0

P0.7	P0.6	P0.5	P0.4	P0.3	P0.2	P0.1	P0.0
------	------	------	------	------	------	------	------

Mnemonic: P0

Address: 80h

P0.7-0: General purpose Input/Output port. Most instructions will read the port pins in case of a port read access, however in case of read-modify-write instructions, the port latch is read. If config0.PRHI=1, the initial value is FFh at reset. If config0.PRHI=0, the initial value is 00h at reset. These alternate functions are described below.

BIT	NAME	FUNCTION
7	P0.7	ADC7 or PWM6 or KB7 pin or I/O pin by alternative.
6	P0.6	ADC6 or /INT1 or KB6 or I/O pin by alternative.
5	P0.5	ADC5 or KB5 or Clock (ICP function) pin or I/O pin by alternative.
4	P0.4	ADC4 or CP1N or KB4 or Data (ICP function) pin or I/O pin by alternative.
3	P0.3	ADC3 or CP1P or KB3 pin or I/O pin by alternative.
2	P0.2	ADC2 or CP2NA or KB2 pin or I/O pin by alternative.
1	P0.1	ADC1 or CP2PA or KB1 pin or I/O pin by alternative.
0	P0.0	ADC0 or OPO or KB0 pin or I/O pin by alternative.

Note: The initial value of the port is set by CONFIG0.PRHI bit. The default setting for CONFIG0.PRHI =1 which the alternative function output is turned on upon reset. If CONFIG0.PRHI is set to 0, the user has to write a 1 to port SFR to turn on the alternative function output.

STACK POINTER

Initial=0000 0111b

Bit: 7 6 5 4 3 2 1 0

SP.7	SP.6	SP.5	SP.4	SP.3	SP.2	SP.1	SP.0
------	------	------	------	------	------	------	------

Mnemonic: SP

Address: 81h

BIT	NAME	FUNCTION
7-0	SP.[7:0]	The Stack Pointer stores the Scratch-pad RAM address where the stack begins. In other words it always points to the top of the stack.

DATA POINTER LOW

Initial=0000 0000b

Bit: 7 6 5 4 3 2 1 0

DPL.7	DPL.6	DPL.5	DPL.4	DPL.3	DPL.2	DPL.1	DPL.0
-------	-------	-------	-------	-------	-------	-------	-------

Mnemonic: DPL

Address: 82h

BIT	NAME	FUNCTION
-----	------	----------

Preliminary N79E875 Data Sheet



7-0	DPL.[7:0]	This is the low byte of the standard 8052 16-bit data pointer.
-----	-----------	--

DATA POINTER HIGH

Initial=0000 0000b

Bit: 7 6 5 4 3 2 1 0

DPH.7	DPH.6	DPH.5	DPH.4	DPH.3	DPH.2	DPH.1	DPH.0
-------	-------	-------	-------	-------	-------	-------	-------

Mnemonic: DPH

Address: 83h

BIT	NAME	FUNCTION
7-0	DPH.[7:0]	This is the high byte of the standard 8052 16-bit data pointer. This is the high byte of the DPTR 16-bit data pointer.

DIVIDER

Initial=0000 0000b

Bit: 7 6 5 4 3 2 1 0

CCDIV.1	CCDIV.0	PWMDIV.1	PWMDIV.0	T3DIV.1	T3DIV.0	T0DIV.1	T0DIV.0
---------	---------	----------	----------	---------	---------	---------	---------

Mnemonic: DIV

Address: 86h

BIT	NAME	FUNCTION															
7~6	CCDIV.1~0	Timer 2 clock select:															
		<table border="1"> <tr> <td>CCDIV.1</td> <td>CCDIV.0</td> <td></td> </tr> <tr> <td>0</td> <td>0</td> <td>Timer 2 clock = Fcpu</td> </tr> <tr> <td>0</td> <td>1</td> <td>Timer 2 clock = Fcpu/4</td> </tr> <tr> <td>1</td> <td>0</td> <td>Timer 2 clock = Fcpu/16</td> </tr> <tr> <td>1</td> <td>1</td> <td>Timer 2 clock = Fcpu/32</td> </tr> </table>	CCDIV.1	CCDIV.0		0	0	Timer 2 clock = Fcpu	0	1	Timer 2 clock = Fcpu/4	1	0	Timer 2 clock = Fcpu/16	1	1	Timer 2 clock = Fcpu/32
		CCDIV.1	CCDIV.0														
		0	0	Timer 2 clock = Fcpu													
		0	1	Timer 2 clock = Fcpu/4													
1	0	Timer 2 clock = Fcpu/16															
1	1	Timer 2 clock = Fcpu/32															
PWM clock select:																	
<table border="1"> <tr> <td>PWMDIV.1</td> <td>PWMDIV.0</td> <td></td> </tr> <tr> <td>0</td> <td>0</td> <td>PWM clock = Fcpu</td> </tr> <tr> <td>0</td> <td>1</td> <td>PWM clock = Fcpu/2</td> </tr> <tr> <td>1</td> <td>0</td> <td>PWM clock = Fcpu/4</td> </tr> <tr> <td>1</td> <td>1</td> <td>PWM clock = Fcpu/16</td> </tr> </table>	PWMDIV.1	PWMDIV.0		0	0	PWM clock = Fcpu	0	1	PWM clock = Fcpu/2	1	0	PWM clock = Fcpu/4	1	1	PWM clock = Fcpu/16		
PWMDIV.1	PWMDIV.0																
0	0	PWM clock = Fcpu															
0	1	PWM clock = Fcpu/2															
1	0	PWM clock = Fcpu/4															
1	1	PWM clock = Fcpu/16															
Timer 3 clock select:																	
3~2	T3DIV.1~0	<table border="1"> <tr> <td>T3DIV.1</td> <td>T3DIV.0</td> <td></td> </tr> <tr> <td>0</td> <td>0</td> <td>Timer 3 clock = Fcpu/4</td> </tr> <tr> <td>0</td> <td>1</td> <td>Timer 3 clock = Fcpu/16</td> </tr> <tr> <td>1</td> <td>0</td> <td>Timer 3 clock = Fcpu/32</td> </tr> </table>	T3DIV.1	T3DIV.0		0	0	Timer 3 clock = Fcpu/4	0	1	Timer 3 clock = Fcpu/16	1	0	Timer 3 clock = Fcpu/32			
		T3DIV.1	T3DIV.0														
		0	0	Timer 3 clock = Fcpu/4													
		0	1	Timer 3 clock = Fcpu/16													
1	0	Timer 3 clock = Fcpu/32															



		1	1	Timer 3 clock = Fcpu/128
1~0	TODIV.1~0	Timer 2 clock select:		
		TODIV.1	TODIV.0	
		0	0	Timer 0 clock = Fcpu/4
		0	1	Timer 0 clock = Fcpu/16
		1	0	Timer 0 clock = Fcpu/32
		1	1	Timer 0 clock = Fcpu/128

POWER CONTROL

Initial=00xx 0000b

Bit: 7 6 5 4 3 2 1 0

SMOD	SMOD0	BOF	POR	GF1	GF0	PD	IDL
------	-------	-----	-----	-----	-----	----	-----

Mnemonic: PCON

Address: 87h

BIT	NAME	FUNCTION
7	SMOD	1: This bit doubles the serial port baud rate in mode 1, 2, and 3.
6	SMOD0	0: Framing Error Detection Disable. SCON.7 (SM0/FE) bit is used as SM0 (standard 8052 function). 1: Framing Error Detection Enable. SCON.7 (SM0/FE) bit is used to reflect as Frame Error (FE) status flag.
5	BOF	0: Cleared by software. 1: Set automatically when a brownout reset or interrupt has occurred. Also set at power on.
4	POR	0: Cleared by software. 1: Set automatically when a power-on reset has occurred.
3	GF1	General purpose user flags.
2	GF0	General purpose user flags.
1	PD	1: The CPU goes into the POWER DOWN mode. In this mode, all the clocks are stopped and program execution is frozen.
0	IDL	1: The CPU goes into the IDLE mode. In this mode, the clocks CPU clock stopped, so program execution is frozen. But the clock to the serial, timer and interrupt blocks is not stopped, and these blocks continue operating.

TIMER CONTROL

Initial=0000 0000b

Bit: 7 6 5 4 3 2 1 0

TF1	TR1	TF0	TR0	IE1	IT1	IE0	IT0
-----	-----	-----	-----	-----	-----	-----	-----

Mnemonic: TCON

Address: 88h

BIT	NAME	FUNCTION
7	TF1	Timer 1 Overflow Flag. This bit is set when Timer 1 overflows. It is cleared



		automatically when the program does a timer 1 interrupt service routine. Software can also set or clear this bit.
6	TR1	Timer 1 Run Control. This bit is set or cleared by software to turn timer/counter on or off.
5	TF0	Timer 0 Overflow Flag. This bit is set when Timer 0 overflows. It is cleared automatically when the program does a timer 0 interrupt service routine. Software can also set or clear this bit.
4	TR0	Timer 0 Run Control. This bit is set or cleared by software to turn timer/counter on or off.
3	IE1	Interrupt 1 Edge Detect Flag: Set by hardware when an edge/level is detected on $\overline{INT1}$. This bit is cleared by hardware when the service routine is vectored to only if the interrupt was edge triggered. Otherwise it follows the inverse of the pin.
2	IT1	Interrupt 1 Type Control. Set/cleared by software to specify falling edge/ low level triggered external inputs.
1	IE0	Interrupt 0 Edge Detect Flag. Set by hardware when an edge/level is detected on $\overline{INT0}$. This bit is cleared by hardware when the service routine is vectored to only if the interrupt was edge triggered. Otherwise it follows the inverse of the pin.
0	IT0	Interrupt 0 Type Control: Set/cleared by software to specify falling edge/ low level triggered external inputs.

TIMER MODE CONTROL

Initial=0000 0000b

Bit: 7 6 5 4 3 2 1 0

GATE	C/\overline{T}	M1	M0	GATE	C/\overline{T}	M1	M0
TIMER1				TIMER0			

Mnemonic: TMOD

Address: 89h

BIT	NAME	FUNCTION
7	GATE	Gating control: When this bit is set, Timer/counter 1 is enabled only while the $\overline{INT1}$ pin is high and the TR1 control bit is set. When cleared, the $\overline{INT1}$ pin has no effect, and Timer 1 is enabled whenever TR1 control bit is set.
6	C/\overline{T}	Timer or Counter Select: When clear, Timer 1 is incremented by the internal clock. When set, the timer counts falling edges on the T1 pin.
5	M1	Timer 1 mode select bit 1. See table below.
4	M0	Timer 1 mode select bit 0. See table below.
3	GATE	Gating control: When this bit is set, Timer/counter 0 is enabled only while the $\overline{INT0}$ pin is high and the TR0 control bit is set. When cleared, the $\overline{INT0}$ pin has no effect, and Timer 0 is enabled whenever TR0 control bit is set.



2	$\overline{C/T}$	Timer or Counter Select: When clear, Timer 0 is incremented by the internal clock. When set, the timer counts falling edges on the T0 pin.
1	M1	Timer 0 mode select bit 1. See table below.
0	M0	Timer 0 mode select bit 0. See table below.

M1, M0: Mode Select bits:

M1	M0	MODE
0	0	Mode 0: 8-bit timer/counter TLx serves as 5-bit pre-scale.
0	1	Mode 1: 16-bit timer/counter, no pre-scale.
1	0	Mode 2: 8-bit timer/counter with auto-reload from THx.
1	1	Mode 3: (Timer 0) TL0 is an 8-bit timer/counter controlled by the standard Timer0 control bits. TH0 is an 8-bit timer only controlled by Timer1 control bits. (Timer 1) Timer/Counter 1 is stopped.

TIMER 0 LSB

Initial=0000 0000b

Bit: 7 6 5 4 3 2 1 0

TL0.7	TL0.6	TL0.5	TL0.4	TL0.3	TL0.2	TL0.1	TL0.0
-------	-------	-------	-------	-------	-------	-------	-------

Mnemonic: TL0

Address: 8Ah

BIT	NAME	FUNCTION
7-0	TL0.[7:0]	Timer 0 LSB.

TIMER 1 LSB

Initial=0000 0000b

Bit: 7 6 5 4 3 2 1 0

TL1.7	TL1.6	TL1.5	TL1.4	TL1.3	TL1.2	TL1.1	TL1.0
-------	-------	-------	-------	-------	-------	-------	-------

Mnemonic: TL1

Address: 8Bh

BIT	NAME	FUNCTION
7-0	TL1.[7:0]	Timer 1 LSB.

TIMER 0 MSB

Initial=0000 0000b

Bit: 7 6 5 4 3 2 1 0

TH0.7	TH0.6	TH0.5	TH0.4	TH0.3	TH0.2	TH0.1	TH0.0
-------	-------	-------	-------	-------	-------	-------	-------

Mnemonic: TH0

Address: 8Ch

BIT	NAME	FUNCTION
7-0	TH0.[7:0]	Timer 0 MSB.

TIMER 1 MSB

Initial=0000 0000b



Bit:	7	6	5	4	3	2	1	0
	TH1.7	TH1.6	TH1.5	TH1.4	TH1.3	TH1.2	TH1.1	TH1.0

Mnemonic: TH1

Address: 8Dh

BIT	NAME	FUNCTION
7-0	TH1.[7:0]	Timer 1 MSB.

CLOCK CONTROL

Initial=xxx0 0xxx_b

Bit:	7	6	5	4	3	2	1	0
	-	-	-	T1M	T0M	-	-	-

Mnemonic: CKCON

Address: 8Eh

BIT	NAME	FUNCTION
7-5	-	Reserved.
4	T1M	Timer 1 clock select: 0: Timer 1 uses a divide by 12 clocks. 1: Timer 1 uses a divide by 4clocks.
3	T0M	Timer 0 clock select: 0: Timer 0 uses a divide by 12 clocks. 1: Timer 0 uses a divide by 4 clocks. 4/16/32/128 clocks. The divider selection bits are located in SFR DIV.TODIV[1:0].
2~0	-	Reserved.

PORT 1

Initial=1111_1111_b/0000_0000_b

Bit:	7	6	5	4	3	2	1	0
	P1.7	P1.6	P1.5	P1.4	P1.3	P1.2	P1.1	P1.0

Mnemonic: P1

Address: 90h

P1.7-0: General purpose Input/Output port. Most instructions will read the port pins in case of a port read access, however in case of read-modify-write instructions, the port latch is read. If config0.PRHI=1, the initial value is FFh at reset. If config0.PRHI=0, the initial value is 00h at reset. These alternate functions are described below.

BIT	NAME	FUNCTION
7	P1.7	BKP1 or STADC or I/O pin by alternative.
6	P1.6 ⁽¹⁾	$\overline{INT0}$ interrupt or SDA or I/O pin by alternative.
5	P1.5 ⁽¹⁾	BKP0 or T0 or SCL or Input Pin by alternative.
4	P1.4	\overline{RST} pin or digital input pin by alternative.



3	P1.3	RXD or I/O pin by alternative.
2	P1.2	TXD or I/O pin by alternative.
1	P1.1	XTAL1 or I/O pin by alternative.
0	P1.0	XTAL2 or CLKOUT or I/O pin by alternative.

Note: (1) P1.5 and P1.6 are permanently in open-drain type.

TIMER 3 LSB

Initial=0000 0000b

Bit: 7 6 5 4 3 2 1 0

T3.7	T3.6	T3.5	T3.4	T3.3	T3.2	T3.1	T3.0
------	------	------	------	------	------	------	------

Mnemonic: T3L

Address: 91h

BIT	NAME	FUNCTION
7-0	T3.[7:0]	Timer 3 LSB Bits Register.

TIMER 3 RELOAD/COMPARE LSB

Initial=0000 0000b

Bit: 7 6 5 4 3 2 1 0

RCAP3.7	RCAP3.6	RCAP3.5	RCAP3.4	RCAP3.3	RCAP3.2	RCAP3.1	RCAP3.0
---------	---------	---------	---------	---------	---------	---------	---------

Mnemonic: RCAP3L

Address: 92h

BIT	NAME	FUNCTION
7-0	RCAP3L	Timer 3 Reload/Compare LSB: This register is LSB of a 12-bit reload value when timer 3 is configured in reload/compare mode. During compare mode, this register is a compare register. See SFR T3CON for reload/compare mode.

TIMER 3 RELOAD/COMPARE MSB

Initial=0000 0000b

Bit: 7 6 5 4 3 2 1 0

RCAP3.1 1	RCAP3.1 0	RCAP3.9	RCAP3.8	T3.11	T3.10	T3.9	T3.8
--------------	--------------	---------	---------	-------	-------	------	------

Mnemonic: RCAP3HT3H

Address: 93h

BIT	NAME	FUNCTION
7-4	RCAP3.11~8	Timer 3 Reload/Compare MSB: This register is MSB of a 12-bit reload value when timer 3 is configured in reload/compare mode. During compare mode, this register is a compare register. See SFR T3CON for reload/compare mode.
3-0	T3.11~8	Timer 3 MSB Bits Register.

PWM 4 LOW BITS REGISTER

Initial=0000 0000b

Bit: 7 6 5 4 3 2 1 0



PWM4.7	PWM4.6	PWM4.5	PWM4.4	PWM4.3	PWM4.2	PWM4.1	PWM4.0
--------	--------	--------	--------	--------	--------	--------	--------

Mnemonic: PWM4L

Address: 96h

BIT	NAME	FUNCTION
7:0	PWM4	PWM 4 LSB Bits Register.

PWM 4 HIGH BITS REGISTER

Initial=xxxx 0000b

Bit: 7 6 5 4 3 2 1 0

-	-	-	-	PWM4.11	PWM4.10	PWM4.9	PWM4.8
---	---	---	---	---------	---------	--------	--------

Mnemonic: PWM4H

Address: 97h

BIT	NAME	FUNCTION
7:4	-	Reserved.
3:0	PWM4	PWM 4 MSB Bits Register.

SERIAL PORT CONTROL

Initial=0000 0000b

Bit: 7 6 5 4 3 2 1 0

SM0/FE	SM1	SM2	REN	TB8	RB8	TI	RI
--------	-----	-----	-----	-----	-----	----	----

Mnemonic: SCON

Address: 98h

BIT	NAME	FUNCTION
7	SM0/FE	Serial port mode select bit 0 or Framing Error Flag: The SMOD0 bit in PCON SFR determines whether this bit acts as SM0 or as FE. The operation of SM0 is described below. When used as FE, this bit will be set to indicate an invalid stop bit. This bit must be manually cleared in software to clear the FE condition.
6	SM1	Serial Port mode select bit 1. See table below.
5	SM2	Multiple processors communication. Setting this bit to 1 enables the multiprocessor communication feature in mode 2 and 3. In mode 2 or 3, if SM2 is set to 1, then RI will not be activated if the received 9th data bit (RB8) is 0. In mode 1, if SM2 = 1, then RI will not be activated if a valid stop bit was not received. In mode 0, the SM2 bit controls the serial port clock. If set to 0, then the serial port runs at a divide by 12 clock of the oscillator. This gives compatibility with the standard 8052. When set to 1, the serial clock become divide by 4 of the oscillator clock. This results in faster synchronous serial communication.
4	REN	Receive enable: 0: Disable serial reception. 1: Enable serial reception.
3	TB8	This is the 9th bit to be transmitted in modes 2 and 3. This bit is set and cleared by software as desired.
2	RB8	In modes 2 and 3 this is the received 9th data bit. In mode 1, if SM2 = 0, RB8 is the stop bit that was received. In mode 0 it has no function.



1	TI	Transmit interrupt flag: This flag is set by hardware at the end of the 8th bit time in mode 0, or at the beginning of the stop bit in all other modes during serial transmission. This bit must be cleared by software.
0	RI	Receive interrupt flag: This flag is set by hardware at the end of the 8th bit time in mode 0, or halfway through the stop bits time in the other modes during serial reception. However the restrictions of SM2 apply to this bit. This bit can be cleared only by software.

SM1, SM0: Mode Select bits:

MODE	SM0	SM1	DESCRIPTION	LENGTH	BAUD RATE
0	0	0	Synchronous	8	Tclk divided by 4 or 12
1	0	1	Asynchronous	10	Variable
2	1	0	Asynchronous	11	Tclk divided by 32 or 64
3	1	1	Asynchronous	11	Variable

SERIAL DATA BUFFER

Initial=xxxx xxxxb

Bit: 7 6 5 4 3 2 1 0

SBUF.7	SBUF.6	SBUF.5	SBUF.4	SBUF.3	SBUF.2	SBUF.1	SBUF.0
--------	--------	--------	--------	--------	--------	--------	--------

Mnemonic: SBUF

Address: 99h

BIT	NAME	FUNCTION
7-0	SBUF.[7:0]	Serial data on the serial port is read from or written to this location. It actually consists of two separate internal 8-bit registers. One is the receive register, and the other is the transmit buffer. Any read access gets data from the receive data buffer, while write access is to the transmit data buffer.

INTERRUPT PRIORITY 2

Initial=x0xx 0xx0b

Bit: 7 6 5 4 3 2 1 0

-	PT2	-	-	PSPI	-	-	PET3
---	-----	---	---	------	---	---	------

Mnemonic: IP2

Address: 9Ah

BIT	NAME	FUNCTION
7	-	Reserved.
6	PT2	1: To set interrupt priority of Timer 2 is higher priority level.
5-4	-	Reserved.
3	PSPI	1: To set interrupt priority of SPI is higher priority level.
2~1	-	Reserved.
0	PET3	1: To set interrupt priority of Timer 3 is higher priority level.



PWM IO REGISTER

Initial=0000 0000b

Bit: 7 6 5 4 3 2 1 0

PIO7	PIO6	PIO5	PIO4	PIO3	PIO2	PIO1	PIO0
------	------	------	------	------	------	------	------

Mnemonic: PIO

Address: 9Bh

BIT	NAME	FUNCTION
7~0	PIO _n	PWM or IO Function Select bit: Select pin output source from PWM or I/O register. 0: Port pin output from port I/O bit register. 1: Port pin output from PWM generator. (Note: n = 0~7).

ADC COMPARE REFERENCE LOW DATA/COMPARE REGISTER

Initial=0010 xx00b

Bit: 7 6 5 4 3 2 1 0

ADCR.1	ADCR.0	ADCPO	ADCPi	-	-	T3CSS	ENADCP
--------	--------	-------	-------	---	---	-------	--------

Mnemonic: ADCRL

Address: 9Ch

BIT	NAME	FUNCTION
7-6	ADCR.1-0	The 2 MSB bits of ADC compare reference data. Note: These 2 bits are writable only when they are written with ENADCP = 0.
5	ADCPO	ADC Compare output (Read Only). 0: The conversion result is less than reference value. 1: The conversion result is equal or larger than reference value.
4	ADCPi	ADC Compare Change Flag If the ADC compare output status is changed, this bit will be set by hardware. This flag is cleared by software only.
3-2	-	Reserved.
1	T3CSS	Timer 3 external trigger source: 0: T3EX pin is the timer 3 trigger source. 1: ADC compare result, ADCPO, is timer 3 trigger source.
0	ENADCP	ADC Compare Function Enable bit: 0: Disable ADC compare function. 1: Enable ADC compare function.

ADC COMPARE REFERENCE HIGH DATA REGISTER

Initial=xxxx xxxb

Bit: 7 6 5 4 3 2 1 0

ADCR.9	ADCR.8	ADCR.7	ADCR.6	ADCR.5	ADCR.4	ADCR.3	ADCR.2
--------	--------	--------	--------	--------	--------	--------	--------

Mnemonic: ADCRH

Address: 9Dh



BIT	NAME	FUNCTION
7-0	ADCR.9-2	The 8 MSB bits of ADC compare reference data. Note: These bits are writable only when ADC compare function is disabled (ENADCP=0)

PORT 3 OUTPUT MODE 1

Initial=0000 0000b

Bit: 7 6 5 4 3 2 1 0

P3M1.7	P3M1.6	P3M1.5	P3M1.4	P3M1.3	P3M1.2	P3M1.1	P3M1.0
--------	--------	--------	--------	--------	--------	--------	--------

Mnemonic: P3M1

Address: 9Eh

BIT	NAME	FUNCTION
7-0	P3M1	To control the output configuration of P3 [7:0].

PORT 3 OUTPUT MODE 2

Initial=0000 0000b

Bit: 7 6 5 4 3 2 1 0

P3M2.7	P3M2.6	P3M2.5	P3M2.4	P3M2.3	P3M1.2	P3M2.1	P3M2.0
--------	--------	--------	--------	--------	--------	--------	--------

Mnemonic: P3M2

Address: 9Fh

BIT	NAME	FUNCTION
7-0	P3M2	See as below table.

Port Output Configuration Settings:

PXM1.Y	PXM2.Y	PORT INPUT/OUTPUT MODE
0	0	Quasi-bidirectional
0	1	Push-Pull
1	0	Input Only (High Impedance) PORTS.PxS=0, TTL input PORTS.PxS=1, Schmitt input
1	1	Open Drain

Note: X = 0-4. Y = 0-7 (for port0-3), Y = 0-3 (for port4).

PORT 2

Initial=1111 111b/0000 0000b

Bit: 7 6 5 4 3 2 1 0

P2.7	P2.6	P2.5	P2.4	P2.3	P2.2	P2.1	P2.0
------	------	------	------	------	------	------	------

Mnemonic: P2

Address: A0h

P2.7-0: General purpose Input/Output port. Most instructions will read the port pins in case of a port read access, however in case of read-modify-write instructions, the port latch is read. If config0.PRHI=1, the initial value is FFh at reset. If config0.PRHI=0, the initial value is 00h at reset.



These alternate functions are described below.

BIT	NAME	FUNCTION
7	P2.7	T1 or I/O pin by alternative.
6	P2.6	IC2 or MOSI or I/O pin by alternative.
5	P2.5	IC1 or MISO or I/O pin by alternative.
4	P2.4	IC0 or \overline{SS} pin or I/O pin by alternative.
3	P2.3	T3 or SCLK or I/O pin by alternative.
2	P2.2	PWM4 or I/O pin by alternative.
1	P2.1	PWM2 or CP1O or I/O pin by alternative.
0	P2.0	PWM0 or CP2O or I/O pin by alternative.

KEYBOARD INTERRUPT

Initial=0000 0000b

Bit:	7	6	5	4	3	2	1	0
	KBI.7	KBI.6	KBI.5	KBI.4	KBI.3	KBI.2	KBI.1	KBI.0

Mnemonic: KBI

Address: A1h

BIT	NAME	FUNCTION
7	KBI.7	1: Enable P0.7 as a cause of a Keyboard interrupt.
6	KBI.6	1: Enable P0.6 as a cause of a Keyboard interrupt.
5	KBI.5	1: Enable P0.5 as a cause of a Keyboard interrupt.
4	KBI.4	1: Enable P0.4 as a cause of a Keyboard interrupt.
3	KBI.3	1: Enable P0.3 as a cause of a Keyboard interrupt.
2	KBI.2	1: Enable P0.2 as a cause of a Keyboard interrupt.
1	KBI.1	1: Enable P0.1 as a cause of a Keyboard interrupt.
0	KBI.0	1: Enable P0.0 as a cause of a Keyboard interrupt.

AUX FUNCTION REGISTER 1

Initial=0000 0000b

Bit:	7	6	5	4	3	2	1	0
	KBF	BOD	BOI	LPBOD	SRST	ADCEN	RCCLK	BOS

Mnemonic: AUXR1

Address: A2h

BIT	NAME	FUNCTION
-----	------	----------



7	KBF	Keyboard Interrupt Flag: 1: When any pin of port 0 that is enabled for the Keyboard Interrupt function goes low. Must be cleared by software.
6	BOD	Brown Out Disable: 0: Enable Brownout Detect function. 1: Disable Brownout Detect function and save power.
5	BOI	Brown Out Interrupt: 0: Brownout detection will cause chip brownout reset. 1: This prevents brownout detection from causing a chip reset and allows the Brownout Detect function to be used as an interrupt.
4	LPBOD	Low Power Brown Out Detect control: 0: If bit BOD=0, the Brown Out detection is always active. 1: If bit BOD=0, the Brown Out detection repeats to senses the voltage for $64/f_{BRC}$ then turn off detector for $960/f_{BRC}$, therefore, it saves 15/16 of the Brownout circuit power.
3	SRST	Software reset: 1: Reset the chip as if a hardware reset occurred. (User must specially take care of setting SRST when a write access on AUXR1)
2	ADCEN	0: Disable ADC circuit. 1: Enable ADC circuit.
1	RCCLK	0: The CPU clock is used as ADC clock source. 1: The internal RC 22.1184MHz/11.0592MHz (selectable by CONFIG1.FS1 bit) clock is used as ADC clock source. Note: This bit can only be set/cleared when ADCEN=0. The ADC clock source will goes through pre-scalar of /1, /2, /4 or /8, selectable by ADCLK bits (SFR ADCCON1.6-7).
0	BOS	Brownout Status bit(Read only) 0: V_{DD} is above V_{BOR+} 1: V_{DD} is below V_{BOR-}

CAPTURE CONTROL 0 REGISTER

Initial=0000 0000b

Bit: 7 6 5 4 3 2 1 0

CCT2	CCT1	CCT0	CCLD
------	------	------	------

Mnemonic: CAPCON0

Address: A3h

BIT	NAME	FUNCTION
7~6	CCT2.1~0	Capture 2 edge select: 00 : Rising edge trigger. 01 : Falling edge trigger. 10 : Both rising and falling edge trigger.



		11 : Reserved.
5~4	CCT1.1~0	Capture 1 edge select: 00 : Rising edge trigger. 01 : Falling edge trigger. 10 : Both rising and falling edge trigger. 11 : Reserved.
3~2	CCT0.1~0	Capture 0 edge select: 00 : Rising edge trigger. 01 : Falling edge trigger. 10 : Both rising and falling edge trigger. 11 : Reserved
1~0	CCLD.1~0	Reload trigger select: 00 : Timer 2 overflow. 01 : Reload by capture 0 block. 10 : Reload by capture 1 block. 11 : Reload by capture 2 block.

CAPTURE CONTROL 1 REGISTER

Initial=x000 0000b

Bit: 7 6 5 4 3 2 1 0

-	IC0SS	ENF2	ENF1	ENF0	CPTF2	CPTF1	CPTF0
---	-------	------	------	------	-------	-------	-------

Mnemonic: CAPCON1

Address: A4h

BIT	NAME	FUNCTION
7	-	Reserved.
6	IC0SS	Input capture 0 source select: 0: P2.4 pin as input capture 0 trigger source. 1: ADC compare result, ADCPO, as input capture 0 trigger source.
5	ENF2	Enable filter for capture input 2.
4	ENF1	Enable filter for capture input 1.
3	ENF0	Enable filter for capture input 0.
2	CPTF2	External capture/reload 2 interrupt flag.
1	CPTF1	External capture/reload 1 interrupt flag.
0	CPTF0	External/ADCPO capture/reload 0 interrupt flag.



PORT 4

Initial=xxxx 1111b/xxxx 0000b

Bit: 7 6 5 4 3 2 1 0

-	-	-	-	P4.3	P4.2	P4.1	P4.0
---	---	---	---	------	------	------	------

Mnemonic: P4

Address: A5h

P4.3-0: General purpose Input/Output port. Most instructions will read the port pins in case of a port read access, however in case of read-modify-write instructions, the port latch is read. If config0.PRHI=1, the initial value is xxxx_1111b at reset. If config0.PRHI=0, the initial value is xxxx_0000b at reset. These alternate functions are described below.

BIT	NAME	FUNCTION
7-4	-	Reserved.
3	P4.3	Dedicated I/O pin.
2	P4.2	Dedicated I/O pin.
1	P4.1	CP2PB or I/O pin by alternative.
0	P4.0	CP2NB or I/O pin by alternative.

INPUT CAPTURE 2 LOW REGISTER

Initial=0000 0000b

Bit: 7 6 5 4 3 2 1 0

CCL2.7	CCL2.6	CCL2.5	CCL2.4	CCL2.3	CCL2.2	CCL2.1	CCL2.0
--------	--------	--------	--------	--------	--------	--------	--------

Mnemonic: CCL2

Address: A6h

BIT	NAME	FUNCTION
7~0	CCL2.7~0	Capture 2 LSB bits.

INPUT CAPTURE 2 HIGH REGISTER

Initial=0000 0000b

Bit: 7 6 5 4 3 2 1 0

CCH2.7	CCH2.6	CCH2.5	CCH2.4	CCH2.3	CCH2.2	CCH2.1	CCH2.0
--------	--------	--------	--------	--------	--------	--------	--------

Mnemonic: CCH2

Address: A7h

BIT	NAME	FUNCTION
7~0	CCH2.7~0	Capture 2 MSB bits.

INTERRUPT ENABLE

Initial=0000 0000b

Bit: 7 6 5 4 3 2 1 0

EA	EADC	EBO	ES	ET1	EX1	ET0	EX0
----	------	-----	----	-----	-----	-----	-----

Mnemonic: IE

Address: A8h

BIT	NAME	FUNCTION
-----	------	----------



7	EA	Global enable. Enable/Disable all interrupts.
6	EADC	Enable ADC interrupt.
5	EBO	Enable Brown Out interrupt.
4	ES	Enable Serial Port 0 interrupt.
3	ET1	Enable Timer 1 interrupt.
2	EX1	Enable external interrupt 1.
1	ET0	Enable Timer 0 interrupt.
0	EX0	Enable external interrupt 0.

SLAVE ADDRESS

Initial=0000 0000b

Bit: 7 6 5 4 3 2 1 0

SADDR.7	SADDR.6	SADDR.5	SADDR.4	SADDR.3	SADDR.2	SADDR.1	SADDR.0
---------	---------	---------	---------	---------	---------	---------	---------

Mnemonic: SADDR

Address: A9h

BIT	NAME	FUNCTION
7~0	SADDR	The SADDR should be programmed to the given or broadcast address for serial port 0 to which the slave processor is designated.

PWM DEAD-TIME CONNTER REGISTER

Initial=0000 0000b

Bit: 7 6 5 4 3 2 1 0

DTCNT.7	DTCNT.6	DTCNT.5	DTCNT.4	DTCNT.3	DTCNT.2	DTCNT.1	DTCNT.0
---------	---------	---------	---------	---------	---------	---------	---------

Mnemonic: DTCNT

Address: ABh

BIT	NAME	FUNCTION
7~0	DTCNT.7~0	Dead-time counter. Unsigned 8-bit dead time value bits for Dead Time Unit. Dead-time = $F_{CPU} * (DTCNT.[7:0]+1)$

Note: This SFR is TA protected.

COMPARATOR 1 CONTROL REGISTER

Initial=x00x 0000b

Bit: 7 6 5 4 3 2 1 0

-	HYSEN1	COMPEN1	-	CN1	COE1	CO1	CMF1
---	--------	---------	---	-----	------	-----	------

Mnemonic: CMP1

Address: ACh

BIT	NAME	FUNCTION
7	-	Reserved.

6	HYSEN1	Hysterisis function enable (comparator 1): 0: Without Hysterisis at comparator 1 inputs. (Default). 1: Enable Hysterisis function at comparator 1 that the typical range is about 20mV.
5	CMPEN1	Comparator enable: 0: Disable Comparator. 1: Enabled Comparator. Comparator output need wait stable 10 us after CMPEN1 is first set.
4	-	Reserved.
3	CN1	Comparator negative input select: 0: The comparator reference pin CNG1 is selected as the negative comparator input. 1: The internal comparator reference Vref is selected as the negative comparator input.
2	COE1	Output enable: 1: The comparator output is connected to the CMP1 pin if the comparator is enabled (CMPEN1 = 1). This output is asynchronous to the CPU clock.
1	CO1	Comparator output: Synchronized to the CPU clock to allow reading by software. Cleared when the comparator is disabled (CMPEN1 = 0).
0	CMF1	Comparator interrupt flag: This bit is set by hardware whenever the comparator output changes state. This bit will cause a hardware interrupt if enabled and of sufficient priority. Cleared by software and when the comparator is disabled (CMPEN1 = 0).

COMPARATOR 2 CONTROL REGISTER

Initial=x000 0000b

Bit:	7	6	5	4	3	2	1	0
	-	HYSEN2	CMPEN2	CP2	CN2	COE2	CO2	CMF2

Mnemonic: CMP2

Address: ADh

BIT	NAME	FUNCTION
7	-	Reserved.
6	HYSEN2	Hysterisis function enable (comparator 2): 0: Without Hysterisis at comparator 2 inputs. (Default). 1: Enable Hysterisis function at comparator 2 that the typical range is about 20mV.



5	CMPEN2	Comparator enable: 0: Disable Comparator. 1: Enabled Comparator. Comparator output need wait stable 10 us after CMPEN2 is first set.
4	CP2	Comparator 2 inputs select: 0: (CP2PA, CP2NA) pair comparator 2 input pair is selected. 1: (CP2PB, CP2NB) pair comparator 2 input pair is selected.
3	CN2	Comparator negative input select: 0: The comparator reference pin CNG2 is selected as the negative comparator input. 1: The internal comparator reference Vref is selected as the negative comparator input.
2	COE2	Output enable: 1: The comparator output is connected to the CMP2 pin if the comparator is enabled (CMPEN2 = 1). This output is asynchronous to the CPU clock.
1	CO2	Comparator output: Synchronized to the CPU clock to allow reading by software. Cleared when the comparator is disabled (CMPEN2 = 0).
0	CMF2	Comparator interrupt flag: This bit is set by hardware whenever the comparator output changes state. This bit will cause a hardware interrupt if enabled and of sufficient priority. Cleared by software and when the comparator is disabled (CMPEN2 = 0).

PWM DEAD-TIME CONTROL 0 REGISTER

Initial=xxxx x000b

Bit:	7	6	5	4	3	2	1	0
	-	-	-	-	-	DTENB4	DTENB2	DTENB0

Mnemonic: PDTC0

Address: AEh

BIT	NAME	FUNCTION
7-3	-	Reserved.
2	DTENB4	Enable dead-time insertion for PWM pair (PWM4, PWM5): Dead-time insertion is only active when this pair of complementary PWM is enabled. If dead-time insertion is inactive, the outputs of pin pair are complementary without any delay. 0: Disable dead-time insertion on the pin pair (PWM4, PWM5). 1: Enable dead-time insertion on the pin pair (PWM4, PWM5).



1	DTENB2	<p>Enable dead-time insertion for PWM pair (PWM2, PWM3):</p> <p>Dead-time insertion is only active when this pair of complementary PWM is enabled. If dead-time insertion is inactive, the outputs of pin pair are complementary without any delay.</p> <p>0: Disable dead-time insertion on the pin pair (PWM2, PWM3).</p> <p>1: Enable dead-time insertion on the pin pair (PWM2, PWM3).</p>
0	DTENB0	<p>Enable dead-time insertion for PWM pair (PWM0, PWM1):</p> <p>Dead-time insertion is only active when this pair of complementary PWM is enabled. If dead-time insertion is inactive, the outputs of pin pair are complementary without any delay.</p> <p>0: Disable dead-time insertion on the pin pair (PWM0, PWM1).</p> <p>1: Enable dead-time insertion on the pin pair (PWM0, PWM1).</p>

Note: This SFR is TA protected.

ADC DELAY START REGISTER

Initial=0000 0000b

Bit:	7	6	5	4	3	2	1	0
	ADCDLY .7	ADCDLY .6	ADCDLY .5	ADCDLY .4	ADCDLY .3	ADCDLY .2	ADCDLY .1	ADCDLY .0

Mnemonic: ADCDLY

Address: AFh

BIT	NAME	FUNCTION
7~0	ADCDLY	<p>These are 8 bits start register to delay start of ADC conversion after detection of ADC start conversion edge by PWM trigger source (controllable through SFR ADCCON1.PWMSRC.1~0) and trigger type (controllable through SFR ADCCON1.STADCT.1~0).</p> <p>An internal 8 bits delay counter will run on PWM clock. When the internal counter matches ADCDLY value, ADC will start conversion.</p> <p>PMU trigger delay time = (ADCDLY+1)/(Fcpu/(4*Divider)).</p> <p>Divider is defined in SFR ADCCON1.3.</p>

Note: User required to clear ADCEN (ADCEN = 0) when re-configure this SFR.

PORT 3

Initial=1111 1111b/0000 0000b

Bit:	7	6	5	4	3	2	1	0
	P3.7	P3.6	P3.5	P3.4	P3.3	P3.2	P3.1	P3.0

Mnemonic: P3

Address: B0h

P3.7-0: General purpose Input/Output port. Most instructions will read the port pins in case of a port read access, however in case of read-modify-write instructions, the port latch is read. If config0.PRHI=1, the initial value is 1111_1111b at reset. If config0.PRHI=0, the initial value is 0000_0000b at reset. These alternate functions are described below.

BIT	NAME	FUNCTION
-----	------	----------



7	P3.7	OPN or I/O pin by alternative.
6	P3.6	OPP or I/O pin by alternative.
5	P3.5	Dedicated I/O pin.
4	P3.4	Dedicated I/O pin.
3	P3.3	PWM7 or I/O pin by alternative.
2	P3.2	PWM5 or I/O pin by alternative.
1	P3.1	PWM3 or I/O pin by alternative.
0	P3.0	PWM1 or I/O pin by alternative.

PORT 0 OUTPUT MODE 1

Initial=0000 0000b

Bit:	7	6	5	4	3	2	1	0
	P0M1.7	P0M1.6	P0M1.5	P0M1.4	P0M1.3	P0M1.2	P0M1.1	P0M1.0
Mnemonic: P0M1								Address: B1h

BIT	NAME	FUNCTION
7-0	P0M1	To control the output configuration of P0 bits [7:0]

PORT 0 OUTPUT MODE 2

Initial=0000 0000b

Bit:	7	6	5	4	3	2	1	0
	P0M2.7	P0M2.6	P0M2.5	P0M2.4	P0M2.3	P0M2.2	P0M2.1	P0M2.0
Mnemonic: P0M2								Address: B2h

BIT	NAME	FUNCTION
7-0	P0M2	To control the output configuration of P0 bits [7:0]

PORT 1 OUTPUT MODE 1

Initial=0xxx 0000b

Bit:	7	6	5	4	3	2	1	0
	P1M1.7	-	-	-	P1M1.3	P1M1.2	P1M1.1	P1M1.0
Mnemonic: P1M1								Address: B3h

BIT	NAME	FUNCTION
7	P1M1.7	To control the output configuration of P1 bit [7].
6-4	-	Reserved.
3-0	P1M1.3-0	To control the output configuration of P1 bits [3:0].

PORT 1 OUTPUT MODE 2

Initial=0xxx 0000b

Publication Release Date: April 13, 2009
Revision A02



Bit: 7 6 5 4 3 2 1 0

P1M2.7	-	-	-	P1M2.3	P1M2.2	P1M2.1	P1M2.0
--------	---	---	---	--------	--------	--------	--------

Mnemonic: P1M2

Address: B4h

BIT	NAME	FUNCTION
7	P1M2	To control the output configuration of P1 bits [7].
6-4	-	Reserved.
3-0	P1M2.3-0	To control the output configuration of P1 bits [3:0].

PORT 2 OUTPUT MODE 1

Initial=0000 0000b

Bit: 7 6 5 4 3 2 1 0

P2M1.7	P2M1.6	P2M1.5	P2M1.4	P2M1.3	P2M1.2	P2M1.1	P2M1.0
--------	--------	--------	--------	--------	--------	--------	--------

Mnemonic: P2M1

Address: B5h

BIT	NAME	FUNCTION
7-0	P2M1	To control the output configuration of P2 bits [7:0]

PORT 2 OUTPUT MODE 2

Initial=0000 0000b

Bit: 7 6 5 4 3 2 1 0

P2M2.7	P2M2.6	P2M2.5	P2M2.4	P2M2.3	P2M2.2	P2M2.1	P2M2.0
--------	--------	--------	--------	--------	--------	--------	--------

Mnemonic: P2M2

Address: B6h

BIT	NAME	FUNCTION
7-0	P2M2	To control the output configuration of P2 bits [7:0]

INTERRUPT HIGH PRIORITY

Initial=x000 0000b

Bit: 7 6 5 4 3 2 1 0

-	PADCH	PBOH	PSH	PT1H	PX1H	PT0H	PX0H
---	-------	------	-----	------	------	------	------

Mnemonic: IPOH

Address: B7h

BIT	NAME	FUNCTION
7	-	Reserved
6	PADCH	1: To set interrupt high priority of ADC is highest priority level.
5	PBOH	1: To set interrupt high priority of Brown Out Detector is highest priority level.
4	PSH	1: To set interrupt high priority of Serial port 0 is highest priority level.
3	PT1H	1: To set interrupt high priority of Timer 1 is highest priority level.



2	PX1H	1: To set interrupt high priority of External interrupt 1 is highest priority level.
1	PT0H	1: To set interrupt high priority of Timer 0 is highest priority level.
0	PX0H	1: To set interrupt high priority of External interrupt 0 is highest priority level.

INTERRUPT PRIORITY 0

Initial=x000 0000b

Bit:	7	6	5	4	3	2	1	0
	-	PADC	PBO	PS	PT1	PX1	PT0	PX0

Mnemonic: IP0

Address: B8h

BIT	NAME	FUNCTION
7	-	Reserved
6	PADC	1: To set interrupt priority of ADC is higher priority level.
5	PBO	1: To set interrupt priority of Brown Out Detector is higher priority level.
4	PS	1: To set interrupt priority of Serial port 0 is higher priority level.
3	PT1	1: To set interrupt priority of Timer 1 is higher priority level.
2	PX1	1: To set interrupt priority of External interrupt 1 is higher priority level.
1	PT0	1: To set interrupt priority of Timer 0 is higher priority level.
0	PX0	1: To set interrupt priority of External interrupt 0 is higher priority level.

SLAVE ADDRESS MASK ENABLE

Initial=0000 0000b

Bit:	7	6	5	4	3	2	1	0
	SADEN.7	SADEN.6	SADEN.5	SADEN.4	SADEN.3	SADEN.2	SADEN.1	SADEN.0

Mnemonic: SADEN

Address: B9h

BIT	NAME	FUNCTION
7~0	SADEN	This register enables the Automatic Address Recognition feature of the Serial port. When a bit in the SADEN is set to 1, the same bit location in SADDR will be compared with the incoming serial data. When SADEN is 0, then the bit becomes a "don't care" in the comparison. This register enables the Automatic Address Recognition feature of the Serial port. When all the bits of SADEN are 0, interrupt will occur for any incoming address.

I2C DATA REGISTER

Initial=xxxx xxxxb

Bit:	7	6	5	4	3	2	1	0
	I2DAT.7	I2DAT.6	I2DAT.5	I2DAT.4	I2DAT.3	I2DAT.2	I2DAT.1	I2DAT.0

Mnemonic: I2DAT

Address: BCh

BI	NAME	FUNCTION
----	------	----------

T		
7-0	I2DAT.[7:0]	The data register of I2C.

I2C STATUS REGISTER

Initial=1111 1000b

Bit: 7 6 5 4 3 2 1 0

Bit7	Bit6	Bit5	Bit4	Bit3	Bit2	Bit1	Bit0
------	------	------	------	------	------	------	------

Mnemonic: I2STATUS

Address: BDh

BI T	NAME	FUNCTION
7-0	I2STATUS.[7:0]	<p>The status register of I2C:</p> <p>The three least significant bits are always 0. The five most significant bits contain the status code. There are 26 possible status codes. When I2STATUS contains F8H, no serial interrupt is requested. All other I2STATUS values correspond to defined I2C states. When each of these states is entered, a status interrupt is requested (SI = 1). A valid status code is present in I2STATUS one machine cycle after SI is set by hardware and is still present one machine cycle after SI has been reset by software. In addition, states 00H stands for a Bus Error. A Bus Error occurs when a START or STOP condition is present at an illegal position in the formation frame. Example of illegal position are during the serial transfer of an address byte, a data byte or an acknowledge bit.</p>

I2C BAUD RATE CONTROL REGISTER

Initial=0000 0000b

Bit: 7 6 5 4 3 2 1 0

I2CLK.7	I2CLK.6	I2CLK.5	I2CLK.4	I2CLK.3	I2CLK.2	I2CLK.1	I2CLK.0
---------	---------	---------	---------	---------	---------	---------	---------

Mnemonic: I2CLK

Address: BEh

BI T	NAME	FUNCTION
7-0	I2CLK.[7:0]	The I2C clock rate bits.

I2C TIMER-OUT COUNTER REGISTER

Initial=xxxx x000b

Bit: 7 6 5 4 3 2 1 0

-	-	-	-	-	ENTI	DIV4	TIF
---	---	---	---	---	------	------	-----

Mnemonic: I2TOC

Address: BFh

BI T	NAME	FUNCTION
7~3	-	Reserved.
2	ENTI	<p>Enable I2C 14-bits Timer Counter:</p> <p>0: Disable 14-bits Timer Counter count.</p> <p>1: Enable 14-bits Timer Counter count. After enable ENTI and ENSI, the 14-bit</p>



		counter will be counted. When SI flag of I2C is set, the counter will stop to count and 14-bits Timer Counter will be cleared.
1	DIV4	I2C Timer Counter clock source divide function: 0: The 14-bits Timer Counter source clock is Fcpu clock. 1: The 14-bits Timer Counter source clock is divided by 4.
0	TIF	The I2C Timer Counter count flag: 0: The 14-bits Timer Counter is not overflow. 1: The 14-bits Timer Counter is overflow and I2C interrupt is requested if the I2C interrupt is enabled. Before enable I2C Timer (ENTI, ENSI = [1,1]) the SI must be cleared. This bit is cleared by software.

I2C CONTROL REGISTER

Initial=x000 00xxb

Bit:	7	6	5	4	3	2	1	0
	-	ENSI	STA	STO	SI	AA	-	-

Mnemonic: I2CON

Address: C0h

BIT	NAME	FUNCTION
7	-	Reserved.
6	ENSI	0: Disable I2C Serial Function. The SDA and SCL output are in a high impedance state. SDA and SCL input signals are ignored, I2C is not in the addressed slave mode or it is not addressable, and STO bit in I2CON is forced to "0". No other bits are affected. Note that P1.5 (SCL) and P1.6 (SDA) are open drain I/O ports. 1: Enable I2C Serial Function. The P1.2 and P1.3 port latches must be to logic 1.
5	STA	The START flag. 0: The STA bit is reset, no START condition or repeated START condition will be generated. 1: The STA bit is set to enter a master mode. The I2C hardware checks the status of I2C bus and generates a START condition if the bus is free. If bus is not free, then I2C waits for a STOP condition and generates a START condition after a delay. If STA is set while I2C is already in a master mode and one or more bytes are transmitted or received, I2C transmits a repeated START condition. STA may be set any time. STA may also be set when I2C interface is an addressed slave mode.
4	STO	In master mode, setting STO to transmit a STOP condition to bus then I2C hardware will check the bus condition if a STOP condition is detected this flag will be cleared by hardware automatically. In a slave mode, setting STO resets I2C hardware to the defined "not addressed" slave mode. This means it is NO LONGER in the slave receiver mode to receive data from the master transmit device. When I2C is in master mode and If the STA and STO bits are both set, a STOP and a START condition will be transmitted to the I2C bus When I2C is in slave mode and if the STA and STO bits are both set, I2C generates an internal STOP condition which is not transmitted to the I2C bus.

3	SI	<p>I2C Serial Port Interrupt Flag</p> <p>0: When the SI flag is reset, no serial interrupt is requested, and there is no stretching on the serial clock on the SCL line.</p> <p>1: When a new SIO state is present in the I2STATUS register, the SI flag is set by hardware, and, if the EA and EI2C(EIE1.0) bits are both set, an I2C interrupt is requested when SI is set. Only one state that does not cause SI is set is I2STATUS=F8H, which indicates that no relevant state information is available. When SI is set, the low level cycle of the serial clock on the SCL line is stretched, and the serial transfer is suspended. The high level cycle on the SCL line is unaffected by the serial interrupt flag. SI must be cleared by software.</p>
2	AA	<p>The Assert Acknowledge Flag</p> <p>0: A not acknowledge (high level to SDA) will be returned during the acknowledge clock pulse on SCL when: 1) A data has been received while SIO is in the master receiver mode. 2) A data byte has been received while SIO is in the addressed slave receiver mode.</p> <p>1: An acknowledge (low level to SDA) will be returned during the acknowledge clock pulse on the SCL line when: 1) The own slave address has been received. 2) A data byte has been received while SIO is in the master receiver mode. 3) A data byte has been received while SIO is in the addressed slave receiver mode. 4) The General Call address has been received while the general call bit (GC) in I2ADDR is set.</p>
1~0	-	Reserved.

新唐科技 NUVOTON
INTELLECTUAL PROPERTY



I2C ADDRESS REGISTER

Initial=xxxx xxx0b

Bit: 7 6 5 4 3 2 1 0

I2ADDR.7	I2ADDR.6	I2ADDR.5	I2ADDR.4	I2ADDR.3	I2ADDR.2	I2ADDR.1	GC
----------	----------	----------	----------	----------	----------	----------	----

Mnemonic: I2ADDR

Address: C1h

BIT	NAME	FUNCTION
7~1	I2ADDR.[7:1]	I2C Address register: The content of this register is irrelevant when I2C is in master mode. In the slave mode, the seven most significant bits must be loaded with the MCU's own address. The I2C hardware will react if either of the address is matched.
0	GC	General Call Function. 0: Disable General Call Function. 1: Enable General Call Function.

TIMER 3 CONTROL REGISTER

Initial=0000 0000b

Bit: 7 6 5 4 3 2 1 0

TF3	EXF3	T3CNTE	T3OE	T3RST	TR3	T3MOD. 1	T3MOD. 0
-----	------	--------	------	-------	-----	-------------	-------------

Mnemonic: T3CON

Address: C2h

BI T	NAME	FUNCTION
7	TF3	Timer 3 overflow interrupt flag: This bit is set when Timer 3 overflows. It is cleared only by software. Software can also set this bit.
6	EXF3	Timer 3 capture and compare match interrupt flag: It is set when there is a capture event in capture mode or the count is equal to the capture register in compare mode. It is cleared only by software. Software can also set this bit.
5	T3CNTE	Timer or counter select: When clear, Timer 3 is incremented by the internal clock. When set, the timer counts falling edges on the T3 pin.
4	T3OE	Timer 3 output enable: 1: The T3 pin is toggled whenever Timer 3 overflows. The output frequency is therefore one half of the Timer 3 overflow rate.
3	T3RST	Timer 3 capture/compare match reset: In the Timer 3 capture/compare modes, this bit enables/disables hardware automatically reset timer 3 while the value in TL3 and TH3 have been transferred into the capture register, or compare matched occur.
2	TR3	Timer 3 run control:

		This bit enables/disables the operation of timer 3. Halting this will preserve the current count in TH3 and TL3.
1~0	T3MOD.1~0	Timer 3 mode selection bits: 00: Timer mode 01: Capture mode 10: Auto-reload mode 11: Compare mode

PWM Negative Polarity

Initial=xx00 0000b

Bit: 7 6 5 4 3 2 1 0

-	-	PNP.5	PNP.4	PNP.3	PNP.2	PNP.1	PNP.0
---	---	-------	-------	-------	-------	-------	-------

Mnemonic: PNP

Address: C3h

BIT	NAME	FUNCTION
7-6	-	Reserved.
5~0	PNP.n	PWM negative polarity bit: The register bit control the initial state as well as polarity/active state of PWM output. 0 = PWMx output is active high (initial state = 0). 1 = PWMx output is active low (initial state = 1).

NVM HIGH BYTE ADDRESS

Initial=xxxx xxx0b

Bit: 7 6 5 4 3 2 1 0

-	-	-	-	-	-	-	NVMADDR.8
---	---	---	---	---	---	---	-----------

Mnemonic: NVMADDRH

Address: C5h

BIT	NAME	FUNCTION
7-1	-	Reserved.
0	NVMADDR.[8]	The NVM high address: The register indicates NVM data memory of high byte address on On-Chip code memory space.

NVM LOW BYTE ADDRESS

Initial=0000 0000b

Bit: 7 6 5 4 3 2 1 0

NVMADDR.7	NVMADDR.6	NVMADDR.5	NVMADDR.4	NVMADDR.3	NVMADDR.2	NVMADDR.1	NVMADDR.0
-----------	-----------	-----------	-----------	-----------	-----------	-----------	-----------

Mnemonic: NVMADDRL

Address: C6h

BIT	NAME	FUNCTION
7~0	NVMADDR.[7:0]	The NVM low byte address:



]	The register indicates NVM data memory of low byte address on On-Chip code memory space.
--	---	--

TIMED ACCESS

Initial=0000 0000b

Bit: 7 6 5 4 3 2 1 0

TA.7	TA.6	TA.5	TA.4	TA.3	TA.2	TA.1	TA.0
------	------	------	------	------	------	------	------

Mnemonic: TA

Address: C7h

BIT	NAME	FUNCTION
7-0	TA.[7:0]	The Timed Access register: The Timed Access register controls the access to protected bits. To access protected bits, the user must first write AAH to the TA. This must be immediately followed by a write of 55H to TA. Now a window is opened in the protected bits for three machine cycles, during which the user can write to these bits.

TIMER 2 CONTROL

Initial=0xxx x0x0b

Bit: 7 6 5 4 3 2 1 0

TF2	-	-	-	-	TR2	-	CMP/RL2
-----	---	---	---	---	-----	---	---------

Mnemonic: T2CON

Address: C8h

BIT	NAME	FUNCTION
7	TF2	Timer 2 overflow flag: This bit is set when Timer 2 overflows. It is also set when the count is equal to the capture register in compare mode. It is cleared only by software. Software can also set this bit.
6~3	-	Reserved.
2	TR2	Timer 2 Run Control: This bit enables/disables the operation of timer 2. Halting this will preserve the current count in TH2, TL2.
1	-	Reserved.
0	CMP/RL2	Compare/Reload Select. This bit determines whether the compare or reload function will be used for timer 2. 0: Auto reload will occur when timer 2 overflows. And reload will be from RCAP register if ENLD = 1. 1: When timer 2 value matches RCAP value, timer 2 will reset to 0.

TIMER 2 MODE CONTROL

Initial=0000 00xxb

Bit: 7 6 5 4 3 2 1 0

ENLD	ICEN2	ICEN1	ICEN0	T2CR	CMPCR	-	-
------	-------	-------	-------	------	-------	---	---

Mnemonic: T2MOD

Address: C9h



BIT	NAME	FUNCTION
7	ENLD	Enable reload from RCAP2 registers to timer 2 counters.
6	ICEN2	Capture 2 External Enable: This bit enables the capture/reload function on the T2 pin. An edge trigger (programmable by CAPCON0.CCT2[1:0] bits) detected on the T2 pin will result in capture from free running timer 2 counters to input capture 2 registers, and reload from RCAP2 registers to timer 2 counters if ENLD = 1 and CMP/RL2 = 0.
5	ICEN1	Capture 1 External Enable: This bit enables the capture/reload function on the T1 pin. An edge trigger (programmable by CAPCON0.CCT1[1:0] bits) detected on the T1 pin will result in capture from free running timer 2 counters to input capture 1 registers, and reload from RCAP2 registers to timer 2 counters if ENLD = 1 and CMP/RL2 = 0.
4	ICEN0	Capture 0 External Enable: This bit enables the capture/reload function on the T0 pin. An edge trigger (programmable by CAPCON0.CCT0[1:0] bits) detected on the T0 pin will result in capture from free running timer 2 counters to input capture 0 registers, and reload from RCAP2 registers to timer 2 counters if ENLD = 1 and CMP/RL2 = 0.
3	T2CR	Timer 2 Capture Reset: In the Timer 2 Capture Mode this bit enables/disables hardware automatically reset timer 2 while the value in TL2 and TH2 have been transferred into the capture register.
2	CMPCR	Compare Counter Reset: Enable counter reset when a match occurs. 0: Disable counter auto-reset in compare mode. 1: Enable counter auto-reset in compare mode.
1~0	-	Reserved.

TIMER 2 RELOAD LSB

Initial=0000 0000b

Bit: 7 6 5 4 3 2 1 0

RCAP2L. 7	RCAP2L. 6	RCAP2L. 5	RCAP2L. 4	RCAP2L. 3	RCAP2L. 2	RCAP2L. 1	RCAP2L. 0
--------------	--------------	--------------	--------------	--------------	--------------	--------------	--------------

Mnemonic: RCAP2L

Address: CAh

BI T	NAME	FUNCTION
7-0	RCAP2L	Timer 2 Reload LSB: This register is LSB of a 16-bit reload value when timer 2 is configured in reload mode. During compare mode, this register is a compare register. See CMP/RL2 for reload/compare mode.

TIMER 2 RELOAD MSB

Initial=0000 0000b

Bit: 7 6 5 4 3 2 1 0

Preliminary N79E875 Data Sheet



RCAP2H .7	RCAP2H .6	RCAP2H .5	RCAP2H .4	RCAP2H .3	RCAP2H .2	RCAP2H .1	RCAP2H .0
--------------	--------------	--------------	--------------	--------------	--------------	--------------	--------------

Mnemonic: RCAP2H

Address: CBh

BIT	NAME	FUNCTION
7-0	RCAP2H	Timer 2 Reload MSB: This register is MSB of a 16-bit reload value when timer 2 is configured in reload mode. During compare mode, this register is a compare register. See CMP/RL2 for reload/compare mode.

TIMER 2 LSB

Initial=0000 0000b

Bit: 7 6 5 4 3 2 1 0

TL2.7	TL2.6	TL2.5	TL2.4	TL2.3	TL2.2	TL2.1	TL2.0
-------	-------	-------	-------	-------	-------	-------	-------

Mnemonic: TL2

Address: CCh

BIT	NAME	FUNCTION
7-0	TL2	Timer 2 LSB.

TIMER 2 MSB

Initial=0000 0000b

Bit: 7 6 5 4 3 2 1 0

TH2.7	TH2.6	TH2.5	TH2.4	TH2.3	TH2.2	TH2.1	TH2.0
-------	-------	-------	-------	-------	-------	-------	-------

Mnemonic: TH2

Address: CDh

BIT	NAME	FUNCTION
7-0	TL2	Timer 2 LSB.

NVM CONTROL

Initial=00xx xxxxb

Bit: 7 6 5 4 3 2 1 0

EER	EWR	-	-	-	-	-	-
-----	-----	---	---	---	---	---	---

Mnemonic: NVMCON

Address: CEh

BIT	NAME	FUNCTION
7	EER	NVM page(n) erase bit: 0: Without erase NVM page(n). 1: Set this bit to erase page(n) of NVM. The NVM has 8 pages and each page have 16 bytes data memory. Initiate page selected by writing NVMADDRH and NVMADDL registers, which will automatically enable page area. When user set this bit, the page erase process will begin and program counter will halt at this instruction. After the erase process is completed, program counter will continue executing next instruction.
6	EWR	NVM data write bit:

		0: Without write NVM data. 1: Set this bit to write NVM bytes and program counter will halt at this instruction. After write is finished, program counter will kept next instruction then executed.
5-0	-	Reserved

NVM DATA

Initial=0000 0000b

Bit: 7 6 5 4 3 2 1 0

NVMDAT. 7	NVMDAT. 6	NVMDAT. 5	NVMDAT. 4	NVMDAT. 3	NVMDAT. 2	NVMDAT. 1	NVMDAT. 0
--------------	--------------	--------------	--------------	--------------	--------------	--------------	--------------

Mnemonic: NVMDATA

Address: CFh

BIT	NAME	FUNCTION
7~0	NVMDAT.[7:0]	The NVM data write register. The read NVM data is by MOVC instruction.

PROGRAM STATUS WORD

Initial=0000 0000b

Bit: 7 6 5 4 3 2 1 0

CY	AC	F0	RS1	RS0	OV	F1	P
----	----	----	-----	-----	----	----	---

Mnemonic: PSW

Address: D0h

BIT	NAME	FUNCTION
7	CY	Carry flag: Set for an arithmetic operation which results in a carry being generated from the ALU. It is also used as the accumulator for the bit operations.
6	AC	Auxiliary carry: Set when the previous operation resulted in a carry from the high order nibble.
5	F0	User flag 0: The General purpose flag that can be set or cleared by the user.
4~3	RS1~RS0	Register bank select bits.
2	OV	Overflow flag: Set when a carry was generated from the seventh bit but not from the 8th bit as a result of the previous operation, or vice-versa.
1	F1	User Flag 1: The General purpose flag that can be set or cleared by the user software.
0	P	Parity flag: Set/cleared by hardware to indicate odd/even number of 1's in the accumulator.



RS.1-0: Register Bank Selection Bits:

RS1	RS0	REGISTER BANK	ADDRESS
0	0	0	00-07h
0	1	1	08-0Fh
1	0	2	10-17h
1	1	3	18-1Fh

PWM COUNTER HIGH BITS REGISTER

Initial=xxxx 0000b

Bit: 7 6 5 4 3 2 1 0

-	-	-	-	PWMP.11	PWMP.10	PWMP.9	PWMP.8
---	---	---	---	---------	---------	--------	--------

Mnemonic: PWMPH

Address: D1h

BIT	NAME	FUNCTION
7-4	-	Reserved.
3-0	PWMP.[11:8]	The PWM Counter Register bits 11~8.

PWM 0 HIGH BITS REGISTER

Initial=xxxx 0000b

Bit: 7 6 5 4 3 2 1 0

-	-	-	-	PWM0.11	PWM0.10	PWM0.9	PWM0.8
---	---	---	---	---------	---------	--------	--------

Mnemonic: PWM0H

Address: D2h

BIT	NAME	FUNCTION
7~4	-	Reserved.
3~0	PWM0.11~8	The PWM 0 Register bit 11~8.

EXTENDED INTERRUPT ENABLE 2 REGISTER

Initial=x0xx 0x00b

Bit: 7 6 5 4 3 2 1 0

-	ET2	-	-	ESPI	-	EADCP	ET3
---	-----	---	---	------	---	-------	-----

Mnemonic: EIE2

Address: D4h

BIT	NAME	FUNCTION
7	-	Reserved.
6	ET2	Timer 2 interrupt enable: 0: Disable Timer 2 Interrupt. 1: Enable Timer 2 Interrupt.

5-4	-	Reserved.
3	ESPI	SPI interrupt enable: 0: Disable SPI Interrupt. 1: Enable SPI Interrupt.
2	-	Reserved.
1	EADCP	Enable ADC Compare Interrupt. 0: Disable ADC compare interrupt source. 1: Enable ADC compare interrupt source.
0	ET3	Timer 3 interrupt enable: 0: Disable Timer 3 Interrupt. 1: Enable Timer 3 Interrupt.

PWM 2 HIGH BITS REGISTER

Initial=xxxx xx00b

Bit:	7	6	5	4	3	2	1	0
	-	-	-	-	-	-	PWM2.9	PWM2.8

Mnemonic: PWM2H

Address: D5h

BIT	NAME	FUNCTION
7~2	-	Reserved.
1~0	PWM2.9~8	The PWM2 Register bit 9~8.

PWM CONTROL REGISTER 3

Initial=xx00 xx00b

Bit:	7	6	5	4	3	2	1	0
	HZ_Even	HZ_Odd	GRP	PWMTYP E	-	-	P6CTRL	INT_TYP E

Mnemonic: PWMCON3

Address: D7h

BIT	NAME	FUNCTION
7	HZ_Even	Control the even PWM ports driving mode: 0: The driving mode of even PWM pins is controlled by output mode registers (PxMy). 1: The driving mode of even PWM pins is forced in Hi-Z mode all the time. The initial value is loaded from config-bit PWM_Even after any reset.
6	HZ_Odd	Control the odd PWM ports driving mode. 0: The driving mode of odd PWM pins is controlled by output mode registers (PxMy). 1: The driving mode of odd PWM pins is forced in Hi-Z mode all the time. The initial value is loaded from config-bit PWM_Odd after any reset.



5	GRP	Group bit 1: Unify the signals timing of PWM0, PWM2 and PWM4 in the same phase which is controlled by PWM0. 0: The signals timing of PWM0, PWM2 and PWM4 are independent.
4	PWMTYPE	PWM mode select bit: 0: Edge-aligned mode. 1: Centre-aligned mode.
3~2		Reserved
1	P6CTRL	PG6 output selection bit: 0: PWM6 output comes from PWM6 frequency/duty generator (if PIO.6 = 1). 1: PWM6 output comes from PWM2 frequency/duty generator (if PIO.6 = 1).
0	INT_TYPE	PWM interrupt type select bit: 0: PWMF will be set if PWM counter underflow. 1: PWMF will be set if PWM counter overflow. Note: This bit is effective when PWM in central align mode only.

WATCHDOG CONTROL

Initial= Refer to the table below

Bit: 7 6 5 4 3 2 1 0

WDRUN	-	WD1	WD0	WDIF	WTRF	EWRST	WDCLR
-------	---	-----	-----	------	------	-------	-------

Mnemonic: WDCON

Address: D8h

BIT	NAME	FUNCTION															
7	WDRUN	0: The Watchdog is stopped. 1: The Watchdog is running.															
6	-	Reserved.															
5~4	WD1~WD0	Watchdog Timer Time-out values selected. <table border="1" style="margin-left: 40px;"> <thead> <tr> <th>WD1</th> <th>WD0</th> <th>WATCHDOG INTERVAL</th> </tr> </thead> <tbody> <tr> <td>0</td> <td>0</td> <td>2^{12}</td> </tr> <tr> <td>0</td> <td>1</td> <td>2^{16}</td> </tr> <tr> <td>1</td> <td>0</td> <td>2^{18}</td> </tr> <tr> <td>1</td> <td>1</td> <td>2^{20}</td> </tr> </tbody> </table>	WD1	WD0	WATCHDOG INTERVAL	0	0	2^{12}	0	1	2^{16}	1	0	2^{18}	1	1	2^{20}
WD1	WD0	WATCHDOG INTERVAL															
0	0	2^{12}															
0	1	2^{16}															
1	0	2^{18}															
1	1	2^{20}															
3	WDIF	Watchdog Timer Interrupt flag: 0: If the interrupt is not enabled, then this bit indicates that the time-out period has elapsed. This bit must be cleared by software. 1: If the watchdog interrupt is enabled, hardware will set this bit to indicate that the watchdog interrupt has occurred.															

2	WTRF	<p>Watchdog Timer Reset flag:</p> <p>1: Hardware will set this bit when the watchdog timer causes a reset. Software can read it but must clear it manually. A power-fail reset will also clear the bit. This bit helps software in determining the cause of a reset. If EWRST = 0, the watchdog timer will have no affect on this bit.</p>
1	EWRST	<p>0: Disable Watchdog Timer Reset.</p> <p>1: Enable Watchdog Timer Reset.</p>
0	WDCLR	<p>Reset Watchdog Timer:</p> <p>This bit helps in putting the watchdog timer into a know state. It also helps in resetting the watchdog timer before a time-out occurs. Failing to set the EWRST before time-out will cause an interrupt (if EWDI (IE.4) is set), and 512 clocks after that a watchdog timer reset will be generated (if EWRST is set). This bit is self-clearing by hardware.</p>

The WDCON SFR is set to a 0x000000B on a power-on-reset. WTRF (WDCON.2) is set to a 1 on a Watchdog timer reset, but to a 0 on power on/down resets. WTRF (WDCON.2) is not altered by an external reset. EWRST (WDCON.1) is set to 0 on all resets.

Reset Type	By external reset	By Watchdog reset	By Power on reset
Value after the reset	0x00 0x00b	0x00 0100b	0x00 000b

All the bits in this SFR have unrestricted read access. WDRUN, WD0, WD1, EWRST, WDIF and WDCLR require Timed Access procedure to write. The remaining bits have unrestricted write accesses. Please refer TA register description.

```

TA          REG          C7H
WDCON      REG          D8H
MOV        TA, #AAH          ; To access protected bits
MOV        TA, #55H
SETB      WDCON.0          ; Reset watchdog timer
ORL       WDCON, #00110000B ; Select 20 bits watchdog timer
MOV        TA, #AAH
MOV        TA, #55H
ORL       WDCON, #00000010B ; Enable watchdog
    
```

PWM COUNTER LOW BITS REGISTER

Initial=0000 0000b

Bit: 7 6 5 4 3 2 1 0

PWMP.7	PWMP.6	PWMP.5	PWP.4	PWMP.3	PWMP.2	PWMP.1	PWMP.1
--------	--------	--------	-------	--------	--------	--------	--------

Mnemonic: PWMPL

Address: D9h

BIT	NAME	FUNCTION
7~0	PWMP	PWM Counter Low Bits Register.



PWM 0 LOW BITS REGISTER

Initial=0000 0000b

Bit: 7 6 5 4 3 2 1 0

PWM0.7	PWM0.6	PWM0.5	PWM0.4	PWM0.3	PWM0.2	PWM0.1	PWM0.1
--------	--------	--------	--------	--------	--------	--------	--------

Mnemonic: PWM0L

Address: DAh

BIT	NAME	FUNCTION
7~0	PWM0	PWM 0 Low Bits Register.

PWM CONTROL REGISTER 1

Initial=0000 0000b

Bit: 7 6 5 4 3 2 1 0

PWMRUN	LOAD	PWMF	CLRPWM	FBK1	FBK0	PMOD.1	PMOD.0
--------	------	------	--------	------	------	--------	--------

Mnemonic: PWMCON1

Address: DCh

BIT	NAME	FUNCTION											
7	PWMRUN	0: The PWM is not running. 1: The PWM counter is running.											
6	LOAD	0: The registers value of PWMP and Comparators are never loaded to counter and Comparator registers. 1: The PWMP register will be load value to counter register after counter underflow, and hardware will clear by next clock cycle.											
5	PWMF	<p>PWM underflow/match PWMP flag.</p> <p>0: No underflow. 1: The flag is set depending on PWM edge or central align mode as follow;</p> <table border="1"> <tr> <td></td> <td>PWMCON3.INT_TYP E bit</td> <td>PWM counter</td> </tr> <tr> <td>Edge Align Mode</td> <td>X</td> <td>Match PWMP.</td> </tr> <tr> <td rowspan="2">Central Align Mode</td> <td>0</td> <td>Underflow</td> </tr> <tr> <td>1</td> <td>Match PWMP.</td> </tr> </table> <p>PWM interrupt is requested if PWM interrupt is enabled.</p>		PWMCON3.INT_TYP E bit	PWM counter	Edge Align Mode	X	Match PWMP.	Central Align Mode	0	Underflow	1	Match PWMP.
	PWMCON3.INT_TYP E bit	PWM counter											
Edge Align Mode	X	Match PWMP.											
Central Align Mode	0	Underflow											
	1	Match PWMP.											
4	CLRPWM	1: Clear 12-bit PWM counter to 000H. It is automatically cleared by hardware.											
3	FBK1	The external brake BKP1 pin Flag. 0: The PWM is not brake by BKP1 pin. 1: The PWM is brake by external brake BKP1 pin. It will be cleared by software.											
2	FBK0	The external brake BKP0 pin Flag. 0: The PWM is not brake by BKP0 pin. 1: The PWM is brake by external brake BKP0 pin. It will be cleared by software.											



1-0	PMOD.1-0	PWM mode selection bits: 00: Independent mode. 01: Pair/Complementary mode. 10: Synchronized mode 11: Reserved.
-----	----------	---

PWM 2 LOW BITS REGISTER

Initial=0000 0000b

Bit: 7 6 5 4 3 2 1 0

PWM2.7	PWM2.6	PWM2.5	PWM2.4	PWM2.3	PWM2.2	PWM2.1	PWM2.0
--------	--------	--------	--------	--------	--------	--------	--------

Mnemonic: PWM2L

Address: DDh

BIT	NAME	FUNCTION
7:0	PWM2	PWM 2 Low Bits Register.

PWM BRAKE OUTPUT

Initial=xx00 0000b

Bit: 7 6 5 4 3 2 1 0

-	-	PWM5B	PWM4B	PWM3B	PWM2B	PWM1B	PWM0B
---	---	-------	-------	-------	-------	-------	-------

Mnemonic: PWMB

Address: DFh

BIT	NAME	FUNCTION
7-6	-	Reserved.
5~0	PWMnB	0 = The PWMn output is low, when Brake is asserted. 1 = The PWMn output is high, when Brake is asserted. (Note: n = 0~5).

ACCUMULATOR

Initial=0000 0000b

Bit: 7 6 5 4 3 2 1 0

ACC.7	ACC.6	ACC.5	ACC.4	ACC.3	ACC.2	ACC.1	ACC.0
-------	-------	-------	-------	-------	-------	-------	-------

Mnemonic: ACC

Address: E0h

BIT	NAME	FUNCTION
7-0	ACC	The A or ACC register is the standard 8052 accumulator.

ADC CONTROL REGISTER

Initial=xx00 0000b

Bit: 7 6 5 4 3 2 1 0

ADC.1	ADC.0	ADCEX	ADCI	ADCS	ADDR2	AADR1	AADR0
-------	-------	-------	------	------	-------	-------	-------

Mnemonic: ADCCON

Address: E1h

BIT	NAME	FUNCTION
-----	------	----------



7~6	ADC.1~0	2 LSB bits of the 10-bit ADC conversion result.
5	ADCEX	<p>Enable STADC and PWM-triggered conversion:</p> <p>0: Conversion can only be started by software (i.e., by setting ADCS).</p> <p>1: Conversion can be started by software or by a rising edge on STADC (pin P1.7) or rising/falling edge on PWM.</p> <p>Note: PWM trigger will be enabled if ADCCON1.STADCT.1 = 1 and ADCEX = 1. This product supports 4 PWM channels for ADC start conversion triggers. User may also select the trigger type of rising or falling edge. User may also control the delay timing of PWM's ADC start trigger. See ADC section for descriptions.</p>
4	ADCI	<p>ADC Interrupt flag:</p> <p>This flag is set when the result of an A/D conversion is ready. This generates an ADC interrupt, if it is enabled. While this flag is 1, the ADC cannot start a new conversion. This bit will be cleared by software.</p>
3	ADCS	<p>ADC Start and Status: Set this bit to start an A/D conversion. It may also be set by STADC if ADCEX is 1. This signal remains high while the ADC is busy and is reset right after ADCI is set.</p> <p>Notes:</p> <ol style="list-style-type: none"> 1. It is recommended to clear ADCI before ADCS is set. However, if ADCI is cleared and ADCS is set at the same time, a new A/D conversion may start on the same channel. 2. Software clearing of ADCS will abort conversion in progress. 3. If ADC is not in Continuous Mode, it cannot start a new conversion while ADCS or ADCI is high.
2~0	AADR2~0	The ADC input select.

The ADCI and ADCS control the ADC conversion as below:

ADCI	ADCS	ADC STATUS
0	0	ADC not busy; A conversion can be started.
0	1	ADC busy; Start of a new conversion is blocked.
1	0	Conversion completed; Start of a new conversion requires ADCI = 0.
1	1	This is an internal temporary state that user can ignore it.

ADDR2, ADDR1, ADDR0: ADC Analog Input Channel select bits:

(Note : These bits should only be changed when ADCI and ADCS are both zero.)

AADR2	AADR1	AADR0	Selected Analog Channel
0	0	0	ADC0 (P0.0)
0	0	1	ADC1 (P0.1)
0	1	0	ADC2 (P0.2)

0	1	1	ADC3 (P0.3)
1	0	0	ADC4 (P0.4)
1	0	1	ADC5 (P0.5)
1	1	0	ADC6 (P0.6)
1	1	1	ADC7 (P0.7)

ADC CONVERTER RESULT REGISTER

Initial=xxxx xxxxb

Bit: 7 6 5 4 3 2 1 0

ADC.9	ADC.8	ADC.7	ADC.6	ADC.5	ADC.4	ADC.3	ADC.2
-------	-------	-------	-------	-------	-------	-------	-------

Mnemonic: ADCH

Address: E2h

BIT	NAME	FUNCTION
7~0	ADC.9~2	8 MSB bits of the 10-bit ADC conversion result.

ADC CONTROL REGISTER 1

Initial=0100 0000b

Bit: 7 6 5 4 3 2 1 0

ADCLK.1	ADCLK.0	STADCT. 1	STADCT. 0	DLYDIV	ADCCM	PWMSRC .1	PWMSRC .0
---------	---------	--------------	--------------	--------	-------	--------------	--------------

Mnemonic: ADCCON1

Address: E3h

BIT	NAME	FUNCTION															
7~6	ADCLK.1~0	<p>ADC Clock Prescaler: The 10-bit ADC needs a clock to drive the converting and the clock frequency need to be within 200KHz to 20MHz. ADCLK[1:0] controls the frequency of the clock to ADC block as below table;</p> <table border="1"> <thead> <tr> <th>ADCLK.1</th> <th>ADCLK.0</th> <th>ADC Clock Frequency</th> </tr> </thead> <tbody> <tr> <td>0</td> <td>0</td> <td>ADCCLK/1</td> </tr> <tr> <td>0</td> <td>1</td> <td>ADCCLK/2 (default)</td> </tr> <tr> <td>1</td> <td>0</td> <td>ADCCLK/4</td> </tr> <tr> <td>1</td> <td>1</td> <td>ADCCLK/8</td> </tr> </tbody> </table>	ADCLK.1	ADCLK.0	ADC Clock Frequency	0	0	ADCCLK/1	0	1	ADCCLK/2 (default)	1	0	ADCCLK/4	1	1	ADCCLK/8
ADCLK.1	ADCLK.0	ADC Clock Frequency															
0	0	ADCCLK/1															
0	1	ADCCLK/2 (default)															
1	0	ADCCLK/4															
1	1	ADCCLK/8															
5~4	STADCT.1~0	<p>STADC Trigger Type selection bits: These bits select rising or falling edge for ADC start trigger type. 00: Triggered by P1.7 rising edge (default). 01: Trigger by PWM rising edge. 10: Trigger by PWM falling edge. 11: Trigger by PWM centre-align (at centre point).</p>															
3	DLYDIV	<p>ADC Delay Clock divider select bit: 0: Divider = 1.</p>															



		1: Divider = 2. The internal counter for PMU trigger delay is clocked by machine clock, Fcpu/4. This bit is meant for dividing the machine clock (Fcpu/4) clock source as per PMU trigger delay time equation below; PMU trigger delay time = (ADCDLY+1)/(Fcpu/(4*DLYDIV)).
2	ADCCM	ADC Continuous Mode 0: Disable ADC continuous mode. 1: Enable ADC continuous mode.
1-0	PWMSRC.1~0	PWM Source selection bits: These bits select PWM channel to cause ADC start conversion. 00: PWM Channel 0. 01: PWM Channel 2. 10: PWM Channel 4. 11: PWM Channel 6.

Note:

User required to clear ADCEN (ADCEN = 0) when re-configure this SFR.

For PWM trigger ADC start conversion in centre align mode, ADC start conversion point will be at the same, regardless of which pwm channel is selected.

INPUT CAPTURE 0 LOW REGISTER

Initial=0000 0000b

Bit: 7 6 5 4 3 2 1 0

CCL0.7	CCL0.6	CCL0.5	CCL0.4	CCL0.3	CCL0.2	CCL0.1	CCL0.0
--------	--------	--------	--------	--------	--------	--------	--------

Mnemonic: CCL0

Address: E4h

BIT	NAME	FUNCTION
7~0	CCL0	Capture 0 low byte.

INPUT CAPTURE 0 HIGH REGISTER

Initial=0000 0000b

Bit: 7 6 5 4 3 2 1 0

CCH0.7	CCH0.6	CCH0.5	CCH0.4	CCH0.3	CCH0.2	CCH0.1	CCH0.0
--------	--------	--------	--------	--------	--------	--------	--------

Mnemonic: CCH0

Address: E5h

BIT	NAME	FUNCTION
7~0	CCH0	Capture 0 high byte.

INPUT CAPTURE 1 LOW REGISTER

Initial=0000 0000b

Bit: 7 6 5 4 3 2 1 0

CCL1.7	CCL1.6	CCL1.5	CCL1.4	CCL1.3	CCL1.2	CCL1.1	CCL1.0
--------	--------	--------	--------	--------	--------	--------	--------

Mnemonic: CCL1

Address: E6h

BIT	NAME	FUNCTION
7~0	CCL1	Capture 1 low byte.

7~0	CCL1	Capture 1 low byte.
-----	------	---------------------

INPUT CAPTURE 1 HIGH REGISTER

Initial=0000 0000b

Bit: 7 6 5 4 3 2 1 0

CCH1.7	CCH1.6	CCH1.5	CCH1.4	CCH1.3	CCH1.2	CCH1.1	CCH1.0
--------	--------	--------	--------	--------	--------	--------	--------

Mnemonic: CCH1

Address: E7h

BIT	NAME	FUNCTION
7~0	CCH1	Capture 1 high byte.

INTERRUPT ENABLE REGISTER 1

Initial=0000 x000b

Bit: 7 6 5 4 3 2 1 0

ECPTF	EPWM	EBRK	EWDI	-	ECI	EKB	EI2C
-------	------	------	------	---	-----	-----	------

Mnemonic: EIE1

Address: E8h

BIT	NAME	FUNCTION
7	ECPTF	0: Disable capture interrupts. 1: Enable capture interrupts.
6	EPWM	0: Disable PWM Interrupt when PWM counter match/underflow. 1: Enable PWM Interrupt when PWM counter match/underflow.
5	EBRK	0: Disable PWM brake interrupt. 1: Enable PWM brake interrupt.
4	EWDI	0: Disable Watchdog Timer Interrupt. 1: Enable Watchdog Timer Interrupt.
3	-	Reserved.
2	ECI	0: Disable Comparator 1 and 2 Interrupt. 1: Enable Comparator 1 and 2 Interrupt.
1	EKB	0: Disable Keypad Interrupt. 1: Enable Keypad Interrupt.
0	EI2C	0: Disable I2C Interrupt. 1: Enable I2C Interrupt.

PORTS SHMITT REGISTER

Initial=xxx0 0000b

Bit: 7 6 5 4 3 2 1 0

-	-	-	P4S	P3S	P2S	P1S	P0S
---	---	---	-----	-----	-----	-----	-----



Mnemonic: PORTS

Address: ECh

BIT	NAME	FUNCTION
7~5	-	Reserved.
4	P4S	1: Enables Schmitt trigger inputs on Port 4.
3	P3S	1: Enables Schmitt trigger inputs on Port 3.
2	P2S	1: Enables Schmitt trigger inputs on Port 2.
1	P1S	1: Enables Schmitt trigger inputs on Port 1.
0	P0S	1: Enables Schmitt trigger inputs on Port 0.

PWM MASK ENABLE REGISTER

Initial=xx00 0000b

Bit:	7	6	5	4	3	2	1	0
	-	-	PME.5	PME.4	PME.3	PME.2	PME.1	PME.0

Mnemonic: PME

Address: EDh

BIT	NAME	FUNCTION
7~6	-	Reserved.
5~0	PME.n	<p>PWM Mask Enable bit: The PWM generator signal will be masked when this bit is enabled. The corresponding PWMn channel will be output with PMD.n data. 0: PWM generator signal is output to next stage. 1: PWM generator signal is masked and PMD.n is output to next stage. (Note: n = 0~5).</p>

PWM MASK DATA REGISTER

Initial=xx00 0000b

Bit:	7	6	5	4	3	2	1	0
	-	-	PMD.5	PMD.4	PMD.3	PMD.2	PMD.1	PMD.0

Mnemonic: PMD

Address: EEh

BIT	NAME	FUNCTION
7~6	-	Reserved.
5~0	PMD.n	<p>PWM Mask Data bit: This data bit control the state of PWMn output pin, if corresponding PME.n = 1. 0: Output logic low to PWMn. 1: Output logic high to PWMn. (Note: n = 0~5).</p>

INTERRUPT HIGH PRIORITY 2

Initial=x0xx 0xx0b

Bit:	7	6	5	4	3	2	1	0
------	---	---	---	---	---	---	---	---



-	PT2H	-	-	PSPIH	-	-	PET3H
---	------	---	---	-------	---	---	-------

Mnemonic: IP2H

Address: EFh

BIT	NAME	FUNCTION
7	-	Reserved.
6	PT2H	1: To set interrupt high priority of Timer 2 is highest priority level.
5~4	-	Reserved.
3	PSPIH	1: To set interrupt high priority of SPI is highest priority level.
2~1	-	Reserved.
0	PET3H	1: To set interrupt high priority of Timer 3 is highest priority level.

B REGISTER

Initial=0000 0000b

Bit: 7 6 5 4 3 2 1 0

B.7	B.6	B.5	B.4	B.3	B.2	B.1	B.0
-----	-----	-----	-----	-----	-----	-----	-----

Mnemonic: B

Address: F0h

BIT	NAME	FUNCTION
7-0	B	The B register is the standard 8052 register that serves as a second accumulator.

SERIAL PERIPHERAL CONTROL REGISTER

Initial=0000 0100b

Bit: 7 6 5 4 3 2 1 0

SSOE	SPE	LSBFE	MSTR	CPOL	CPHA	SPR1	SPR0
------	-----	-------	------	------	------	------	------

Mnemonic: SPCR

Address: F3h

BIT	NAME	FUNCTION
-----	------	----------



7	SSOE	<p>Slave Select Output Enable Bit.</p> <p>The \overline{SS} output feature is enabled only in master mode by asserting the SSOE bit. \overline{SS} input not effected by SSOE when the device in slave mode.</p> <p>0: \overline{SS} input (with mode fault).</p> <p>1: \overline{SS} output (no mode fault).</p>			
		DRS	SSO	Master Mode	Slave Mode
		S	E		
		0	0	\overline{SS} input (With Mode Fault)	\overline{SS} Input (Not affected by SSOE)
		0	1	Reserved	\overline{SS} Input (Not affected by SSOE)
1	0	\overline{SS} General purpose I/O (No Mode Fault)	\overline{SS} Input (Not affected by SSOE)		
1	1	\overline{SS} output (No Mode Fault)	\overline{SS} Input (Not affected by SSOE)		
6	SPE	<p>Serial Peripheral System Enable Bit:</p> <p>When the SPE bit is set, SPI block functions is enable. When MODF is set, SPE always reads 0.</p> <p>0: SPI system disabled.</p> <p>1: SPI system enabled.</p>			
5	LSBFE	<p>LSB - First Enable:</p> <p>This bit does not affect the position of the MSB and LSB in the data register. Reads and writes of the data register always have the MSB in bit 7. In master mode, a change of this bit will abort a transmission in progress and force the SPI system into idle state.</p> <p>0: Data is transferred most significant bit first.</p> <p>1: Data is transferred least significant bit first.</p>			
4	MSTR	<p>Master Mode Select Bit:</p> <p>It is customary to have an external pull-up resistor on lines that are driven by open-drain devices.</p> <p>0: Slave mode.</p> <p>1: Master mode</p>			
3	CPOL	<p>Clock Polarity Bit:</p> <p>When the clock polarity bit is cleared and data is not being transferred, the SCK pin of the master device has a steady state low value. When CPOL is set, SCK idles high.</p>			

2	CPHA	<p>Clock Phase Bit:</p> <p>The clock phase bit, in conjunction with the CPOL bit, controls the clock-data relationship between master and slave. The CPHA bit selects one of two different clocking protocols.</p>															
1~0	SPR1~0	<p>SPI Baud Rate Selection Bits:</p> <p>These bits specify the SPI baud rates.</p> <table border="1"> <thead> <tr> <th>SPR1</th> <th>SPR0</th> <th>Divider</th> </tr> </thead> <tbody> <tr> <td>0</td> <td>0</td> <td>16</td> </tr> <tr> <td>0</td> <td>1</td> <td>32</td> </tr> <tr> <td>1</td> <td>0</td> <td>64</td> </tr> <tr> <td>1</td> <td>1</td> <td>128</td> </tr> </tbody> </table>	SPR1	SPR0	Divider	0	0	16	0	1	32	1	0	64	1	1	128
SPR1	SPR0	Divider															
0	0	16															
0	1	32															
1	0	64															
1	1	128															

Note: In master mode, a change of LSBFE, MSTR, CPOL, CPHA and SPR [1:0] will abort a transmission in progress and force the SPI system into idle state.

SERIAL PERIPHERAL STATUS REGISTER

Initial=0000 0xxx

Bit: 7 6 5 4 3 2 1 0

SPIF	WCOL	SPOVF	MODF	DRSS	-	-	-
------	------	-------	------	------	---	---	---

Mnemonic: SPSR

Address: F4h

BIT	NAME	FUNCTION
7	SPIF	<p>SPI Interrupt Complete Flag:</p> <p>SPIF is set upon completion of data transfer between this device and external device or when new data has been received and copied to the SPDR. If SPIF goes high, and if ESPI (located at EIE2.3) is set, a serial peripheral interrupt is generated. SPIF is clear by software, by writing a 0.</p>
6	WCOL	<p>Write Collision Bit:</p> <p>Clearing the WCOL bit is accomplished by software writing a 0.</p> <p>0: No write collision. 1: Write collision.</p>
5	SPOVF	<p>SPI overrun flag:</p> <p>SPIOVF is set if a new character is received before a previously received character is read from SPDR. Once this bit is set, it will prevent SPDR register from accepting new data. It must be cleared before any new data can be written. This flag is cleared by software, by writing a 0.</p> <p>0: No overrun. 1: Overrun detected.</p>
4	MODF	<p>SPI Mode Error Interrupt Status Flag:</p> <p>Clearing this bit is by software writing a 0.</p> <p>0: No mode fault. 1: Mode fault.</p>



3	DRSS	Data Register Slave Select: Refer to above table in SPCR register.
2~0	-	Reserved.

SERIAL PERIPHERAL DATA I/O REGISTER

Initial=xxxx xxxxb

Bit: 7 6 5 4 3 2 1 0

SPD.7	SPD.6	SPD.5	SPD.4	SPD.3	SPD.2	SPD.1	SPD.0
-------	-------	-------	-------	-------	-------	-------	-------

Mnemonic: SPDR

Address: F5h

BIT	NAME	FUNCTION
7-0	SPDR	SPDR is used when transmitting or receiving data on serial bus.

PORT ADC DIGITAL INPUT DISABLE

Initial=0000 0000b

Bit: 7 6 5 4 3 2 1 0

PADIDS.7	PADIDS.6	PADIDS.5	PADIDS.4	PADIDS.3	PADIDS.2	PADIDS.1	PADIDS.0
----------	----------	----------	----------	----------	----------	----------	----------

Mnemonic: PADIDS

Address: F6h

BIT	NAME	FUNCTION
7	PADIDS.7	P0.7 digital input disable bit. 0: Default (With digital/analog input). 1: Disable Digital Input of ADC Input Channel 7.
6	PADIDS.6	P0.6 digital input disable bit. 0: Default (With digital/analog input). 1: Disable Digital Input of ADC Input Channel 6.
5	PADIDS.5	P0.5 digital input disable bit. 0: Default (With digital/analog input). 1: Disable Digital Input of ADC Input Channel 5.
4	PADIDS.4	P0.4 digital input disable bit. 0: Default (With digital/analog input). 1: Disable Digital Input of ADC Input Channel 4/Comparator 1 (CP1N) input.
3	PADIDS.3	P0.3 digital input disable bit. 0: Default (With digital/analog input). 1: Disable Digital Input of ADC Input Channel 3/Comparator 1 (CP1P) input.
2	PADIDS.2	P0.2 digital input disable bit. 0: Default (With digital/analog input). 1: Disable Digital Input of ADC Input Channel 2/Comparator 2 (CP2N) input.

1	PADIDS.1	P0.1 digital input disable bit. 0: Default (With digital/analog input). 1: Disable Digital Input of ADC Input Channel 1/Comparator 2 (CP2P) input.
0	PADIDS.0	P0.0 digital input disable bit. 0: Default (With digital/analog input). 1: Disable Digital Input of ADC Input Channel 0.

INTERRUPT HIGH PRIORITY 1

Initial=0000 x000b

Bit: 7 6 5 4 3 2 1 0

PCAPH	PPWMH	PBRKH	PWDIH	-	PCIH	PKBH	PI2H
-------	-------	-------	-------	---	------	------	------

Mnemonic: IP1H

Address: F7h

BIT	NAME	FUNCTION
7	PCAPH	1: To set interrupt high priority of Capture 0/1/2 as highest priority level.
6	PPWMH	1: To set interrupt high priority of PWM's counter match/underflow is highest priority level.
5	PBRKH	1: To set interrupt high priority of PWM's brake is highest priority level.
4	PWDIH	1: To set interrupt high priority of Watchdog is highest priority level.
3	-	Reserved.
2	PCIH	1: To set interrupt high priority of Comparator 1 and 2, is highest priority level.
1	PKBH	1: To set interrupt high priority of Keypad is highest priority level.
0	PI2H	1: To set interrupt high priority of I2C is highest priority level.

INTERRUPT PRIORITY 1

Initial=0000 x000b

Bit: 7 6 5 4 3 2 1 0

PCAP	PPWM	PBRK	PWDI	-	PCI	PKB	PI2
------	------	------	------	---	-----	-----	-----

Mnemonic: IP1

Address: F8h

BIT	NAME	FUNCTION
7	PCAP	1: To set interrupt priority of Capture 0/1/2 as higher priority level.
6	PPWM	1: To set interrupt priority of PWM's counter match/underflow is higher priority level.
5	PBRK	1: To set interrupt priority of PWM's brake is higher priority level.
4	PWDI	1: To set interrupt priority of Watchdog is higher priority level.
3	-	Reserved.
2	PC1	1: To set interrupt priority of Comparator 1 and 2, is higher priority level.



1	PKB	1: To set interrupt priority of Keypad is higher priority level.
0	PI2	1: To set interrupt priority of I2C is higher priority level.

PORT 4 OUTPUT MODE 1

Initial=xxxx 0000b

Bit: 7 6 5 4 3 2 1 0

-	-	-	-	P4M1.3	P4M1.2	P4M1.1	P4M1.0
---	---	---	---	--------	--------	--------	--------

Mnemonic: P4M1

Address: FAh

BIT	NAME	FUNCTION
3-0	P4M1	To control the output configuration of P4 bits [3:0]

PORT 4 OUTPUT MODE 2

Initial=xxxx 0000b

Bit: 7 6 5 4 3 2 1 0

-	-	-	-	P4M2.3	P4M2.2	P4M2.1	P4M2.0
---	---	---	---	--------	--------	--------	--------

Mnemonic: P4M2

Address: FBh

BIT	NAME	FUNCTION
3-0	P4M2	To control the output configuration of P4 bits [3:0]

PWM CONTROL REGISTER 4

Initial=0000 0x00b

Bit: 7 6 5 4 3 2 1 0

BK1FILT. 1	BK1FILT. 0	BK0FILT. 1	BK0FILT. 0	AUTOBK1	-	BKEN1	BKEN0
---------------	---------------	---------------	---------------	---------	---	-------	-------

Mnemonic: PWMCON4

Address: FCh

BIT	NAME	FUNCTION
7-6	BK1FILT.1-0	Brake 1 (BKP1 pin) edge detector filter type bits: 00: Filter clock = Fcpu. 01: Filter clock = Fcpu/2. 10: Filter clock = Fcpu/4. 11: Filter clock = Fcpu/8.
5-4	BK0FILT.1-0	Brake 0 (BKP0 pin) edge detector filter type bits: 00: Filter clock = Fcpu. 01: Filter clock = Fcpu/2. 10: Filter clock = Fcpu/4. 11: Filter clock = Fcpu/8.



3	AUTOBK1	<p>Auto-clear Brake condition:</p> <p>0: No change in PWM0-5 output. PWM0-5 output will remain following PWM generators, if brake is caused by BRK1 pin.</p> <p>1: This will cause PWM0-5 output to follow PWMnB bits (see note), when low level is detected at BKP1 pin.</p> <p>Note: PNP bits are also able to control the polarity of PWMnB. If PNP.n=0, PWMn output = PWMnB. If PNP.n=1, PWMn output = invert(PWMnB).</p>
2	-	Reserved.
1	BKEN1	<p>Enable brake 1 (BKP1 pin) falling edge detection:</p> <p>0: Disable brake 1, BKP1 pin, falling edge detect function (default).</p> <p>1: Enable brake 1, BKP1 pin, falling edge detection. FBK1 flag will set if this brake occurs.</p>
0	BKEN0	<p>Enable brake 0 (BKP0 pin) falling edge detection:</p> <p>0: Disable brake 0, BKP0 pin, edge detect function (default).</p> <p>1: Enable brake 0, BKP0 pin, falling edge detection. FBK0 flag will set if this brake occurs.</p>

PWM 6 LOW BITS REGISTER

Initial=0000 0000b

Bit: 7 6 5 4 3 2 1 0

PWM6.7	PWM6.6	PWM6.5	PWM6.4	PWM6.3	PWM6.2	PWM6.1	PWM6.0
--------	--------	--------	--------	--------	--------	--------	--------

Mnemonic: PWM6L

Address: FDh

BIT	NAME	FUNCTION
7:0	PWM6	PWM 6 Low Bits Register.

PWM 6 HIGH BITS REGISTER

Initial=xxxx 0000b

Bit: 7 6 5 4 3 2 1 0

-	-	-	-	PWM6.11	PWM6.10	PWM6.9	PWM6.8
---	---	---	---	---------	---------	--------	--------

Mnemonic: PWM6H

Address: FEh

BIT	NAME	FUNCTION
7:4	-	Reserved.
3:0	PWM6	PWM 6 High Bits Register.

AUX FUNCTION REGISTER 2

Initial=0000 0000b

Bit: 7 6 5 4 3 2 1 0

T1OE	T0OE	PCMP2D IDS.1	PCMP2D IDS.0	POPDIDS	ENCLK	ADC1SEL	ENOP
------	------	-----------------	-----------------	---------	-------	---------	------

Mnemonic: AUXR2

Address: FFh

BIT	NAME	FUNCTION
-----	------	----------

Preliminary N79E875 Data Sheet



7	T1OE	1: The P2.7 pin is toggled whenever Timer 1 overflows. The output frequency is therefore one half of the Timer 1 overflow rate.
6	T0OE	1: The P1.5 pin is toggled whenever Timer 0 overflows. The output frequency is therefore one half of the Timer 0 overflow rate.
5	PCMP2DID S.1	P4.0 digital input disable bit. 0: Default (With digital/analog input). 1: Disable Digital Input of Comparator 2 (CP2NB) input.
4	PCMP2DID S.0	P4.1 digital input disable bit. 0: Default (With digital/analog input). 1: Disable Digital Input of Comparator 2 (CP2PB) input.
3	POPDIDS	P3.6 and P3.7 digital input disable bit. 0: Default (With digital/analog input). 1: Disable Digital Input of Opamp OPP and OPN inputs.
2	ENCLK	1: To use the on-chip RC oscillator, a clock output is enabled on the XTAL2 pin.
1	ADC1SEL	ADC 1 source select bit: 0: From P0.1 input. 1: From Brownout 1.2V output, VBF.
0	ENOP	OP AMP enable: 0: OP Amp disabled. 1: OP Amp enabled.

新唐科技 NUVOTON
INTELLECTUAL PROPERTY



8 INSTRUCTION

The N79E875 series execute all the instructions of the standard 8052 family. The operations of these instructions, as well as their effects on flag and status bits, are exactly same. However, the timing of these instructions is different in two ways. Firstly, the machine cycle is four clock periods, while the standard-8051/52 machine cycle is twelve clock periods. Secondly, it can fetch only once per machine cycle (i.e., four clocks per fetch), while the standard 8051/52 can fetch twice per machine cycle (i.e., six clocks per fetch).

The timing differences create an advantage for the N79E875 series. There is only one fetch per machine cycle, so the number of machine cycles is usually equal to the number of operands in the instruction. (Jumps and calls do require an additional cycle to calculate the new address.) As a result, the N79E875 series reduces the number of dummy fetches and wasted cycles, and therefore improves overall efficiency, compared to the standard 8051/52.

Op-code	HEX Code	Bytes	N79E875 series Machine Cycle	N79E875 series Clock cycles	8032 Clock cycles	N79E875 series vs. 8032 Speed Ratio
NOP	00	1	1	4	12	3
ADD A, R0	28	1	1	4	12	3
ADD A, R1	29	1	1	4	12	3
ADD A, R2	2A	1	1	4	12	3
ADD A, R3	2B	1	1	4	12	3
ADD A, R4	2C	1	1	4	12	3
ADD A, R5	2D	1	1	4	12	3
ADD A, R6	2E	1	1	4	12	3
ADD A, R7	2F	1	1	4	12	3
ADD A, @R0	26	1	1	4	12	3
ADD A, @R1	27	1	1	4	12	3
ADD A, direct	25	2	2	8	12	1.5
ADD A, #data	24	2	2	8	12	1.5
ADDC A, R0	38	1	1	4	12	3
ADDC A, R1	39	1	1	4	12	3
ADDC A, R2	3A	1	1	4	12	3
ADDC A, R3	3B	1	1	4	12	3
ADDC A, R4	3C	1	1	4	12	3

Preliminary N79E875 Data Sheet



Op-code	HEX Code	Bytes	N79E875 series Machine Cycle	N79E875 series Clock cycles	8032 Clock cycles	N79E875 series vs. 8032 Speed Ratio
ADDC A, R5	3D	1	1	4	12	3
ADDC A, R6	3E	1	1	4	12	3
ADDC A, R7	3F	1	1	4	12	3
ADDC A, @R0	36	1	1	4	12	3
ADDC A, @R1	37	1	1	4	12	3
ADDC A, direct	35	2	2	8	12	1.5
ADDC A, #data	34	2	2	8	12	1.5
SUBB A, R0	98	1	1	4	12	3
SUBB A, R1	99	1	1	4	12	3
SUBB A, R2	9A	1	1	4	12	3
SUBB A, R3	9B	1	1	4	12	3
SUBB A, R4	9C	1	1	4	12	3
SUBB A, R5	9D	1	1	4	12	3
SUBB A, R6	9E	1	1	4	12	3
SUBB A, R7	9F	1	1	4	12	3
SUBB A, @R0	96	1	1	4	12	3
SUBB A, @R1	97	1	1	4	12	3
SUBB A, direct	95	2	2	8	12	1.5
SUBB A, #data	94	2	2	8	12	1.5
INC A	04	1	1	4	12	3
INC R0	08	1	1	4	12	3
INC R1	09	1	1	4	12	3
INC R2	0A	1	1	4	12	3
INC R3	0B	1	1	4	12	3
INC R4	0C	1	1	4	12	3
INC R5	0D	1	1	4	12	3
INC R6	0E	1	1	4	12	3

Preliminary N79E875 Data Sheet



Op-code	HEX Code	Bytes	N79E875 series Machine Cycle	N79E875 series Clock cycles	8032 Clock cycles	N79E875 series vs. 8032 Speed Ratio
INC R7	0F	1	1	4	12	3
INC @R0	06	1	1	4	12	3
INC @R1	07	1	1	4	12	3
INC direct	05	2	2	8	12	1.5
INC DPTR	A3	1	2	8	24	3
DEC A	14	1	1	4	12	3
DEC R0	18	1	1	4	12	3
DEC R1	19	1	1	4	12	3
DEC R2	1A	1	1	4	12	3
DEC R3	1B	1	1	4	12	3
DEC R4	1C	1	1	4	12	3
DEC R5	1D	1	1	4	12	3
DEC R6	1E	1	1	4	12	3
DEC R7	1F	1	1	4	12	3
DEC @R0	16	1	1	4	12	3
DEC @R1	17	1	1	4	12	3
DEC direct	15	2	2	8	12	1.5
MUL AB	A4	1	5	20	48	2.4
DIV AB	84	1	5	20	48	2.4
DA A	D4	1	1	4	12	3
ANL A, R0	58	1	1	4	12	3
ANL A, R1	59	1	1	4	12	3
ANL A, R2	5A	1	1	4	12	3
ANL A, R3	5B	1	1	4	12	3
ANL A, R4	5C	1	1	4	12	3
ANL A, R5	5D	1	1	4	12	3
ANL A, R6	5E	1	1	4	12	3

Preliminary N79E875 Data Sheet



Op-code	HEX Code	Bytes	N79E875 series Machine Cycle	N79E875 series Clock cycles	8032 Clock cycles	N79E875 series vs. 8032 Speed Ratio
ANL A, R7	5F	1	1	4	12	3
ANL A, @R0	56	1	1	4	12	3
ANL A, @R1	57	1	1	4	12	3
ANL A, direct	55	2	2	8	12	1.5
ANL A, #data	54	2	2	8	12	1.5
ANL direct, A	52	2	2	8	12	1.5
ANL direct, #data	53	3	3	12	24	2
ORL A, R0	48	1	1	4	12	3
ORL A, R1	49	1	1	4	12	3
ORL A, R2	4A	1	1	4	12	3
ORL A, R3	4B	1	1	4	12	3
ORL A, R4	4C	1	1	4	12	3
ORL A, R5	4D	1	1	4	12	3
ORL A, R6	4E	1	1	4	12	3
ORL A, R7	4F	1	1	4	12	3
ORL A, @R0	46	1	1	4	12	3
ORL A, @R1	47	1	1	4	12	3
ORL A, direct	45	2	2	8	12	1.5
ORL A, #data	44	2	2	8	12	1.5
ORL direct, A	42	2	2	8	12	1.5
ORL direct, #data	43	3	3	12	24	2
XRL A, R0	68	1	1	4	12	3
XRL A, R1	69	1	1	4	12	3
XRL A, R2	6A	1	1	4	12	3
XRL A, R3	6B	1	1	4	12	3
XRL A, R4	6C	1	1	4	12	3
XRL A, R5	6D	1	1	4	12	3

Preliminary N79E875 Data Sheet



Op-code	HEX Code	Bytes	N79E875 series Machine Cycle	N79E875 series Clock cycles	8032 Clock cycles	N79E875 series vs. 8032 Speed Ratio
XRL A, R6	6E	1	1	4	12	3
XRL A, R7	6F	1	1	4	12	3
XRL A, @R0	66	1	1	4	12	3
XRL A, @R1	67	1	1	4	12	3
XRL A, direct	65	2	2	8	12	1.5
XRL A, #data	64	2	2	8	12	1.5
XRL direct, A	62	2	2	8	12	1.5
XRL direct, #data	63	3	3	12	24	2
CLR A	E4	1	1	4	12	3
CPL A	F4	1	1	4	12	3
RL A	23	1	1	4	12	3
RLC A	33	1	1	4	12	3
RR A	03	1	1	4	12	3
RRC A	13	1	1	4	12	3
SWAP A	C4	1	1	4	12	3
MOV A, R0	E8	1	1	4	12	3
MOV A, R1	E9	1	1	4	12	3
MOV A, R2	EA	1	1	4	12	3
MOV A, R3	EB	1	1	4	12	3
MOV A, R4	EC	1	1	4	12	3
MOV A, R5	ED	1	1	4	12	3
MOV A, R6	EE	1	1	4	12	3
MOV A, R7	EF	1	1	4	12	3
MOV A, @R0	E6	1	1	4	12	3
MOV A, @R1	E7	1	1	4	12	3
MOV A, direct	E5	2	2	8	12	1.5
MOV A, #data	74	2	2	8	12	1.5

Preliminary N79E875 Data Sheet



Op-code	HEX Code	Bytes	N79E875 series Machine Cycle	N79E875 series Clock cycles	8032 Clock cycles	N79E875 series vs. 8032 Speed Ratio
MOV R0, A	F8	1	1	4	12	3
MOV R1, A	F9	1	1	4	12	3
MOV R2, A	FA	1	1	4	12	3
MOV R3, A	FB	1	1	4	12	3
MOV R4, A	FC	1	1	4	12	3
MOV R5, A	FD	1	1	4	12	3
MOV R6, A	FE	1	1	4	12	3
MOV R7, A	FF	1	1	4	12	3
MOV R0, direct	A8	2	2	8	12	1.5
MOV R1, direct	A9	2	2	8	12	1.5
MOV R2, direct	AA	2	2	8	12	1.5
MOV R3, direct	AB	2	2	8	12	1.5
MOV R4, direct	AC	2	2	8	12	1.5
MOV R5, direct	AD	2	2	8	12	1.5
MOV R6, direct	AE	2	2	8	12	1.5
MOV R7, direct	AF	2	2	8	12	1.5
MOV R0, #data	78	2	2	8	12	1.5
MOV R1, #data	79	2	2	8	12	1.5
MOV R2, #data	7A	2	2	8	12	1.5
MOV R3, #data	7B	2	2	8	12	1.5
MOV R4, #data	7C	2	2	8	12	1.5
MOV R5, #data	7D	2	2	8	12	1.5
MOV R6, #data	7E	2	2	8	12	1.5
MOV R7, #data	7F	2	2	8	12	1.5
MOV @R0, A	F6	1	1	4	12	3
MOV @R1, A	F7	1	1	4	12	3
MOV @R0, direct	A6	2	2	8	12	1.5

Preliminary N79E875 Data Sheet



Op-code	HEX Code	Bytes	N79E875 series Machine Cycle	N79E875 series Clock cycles	8032 Clock cycles	N79E875 series vs. 8032 Speed Ratio
MOV @R1, direct	A7	2	2	8	12	1.5
MOV @R0, #data	76	2	2	8	12	1.5
MOV @R1, #data	77	2	2	8	12	1.5
MOV direct, A	F5	2	2	8	12	1.5
MOV direct, R0	88	2	2	8	12	1.5
MOV direct, R1	89	2	2	8	12	1.5
MOV direct, R2	8A	2	2	8	12	1.5
MOV direct, R3	8B	2	2	8	12	1.5
MOV direct, R4	8C	2	2	8	12	1.5
MOV direct, R5	8D	2	2	8	12	1.5
MOV direct, R6	8E	2	2	8	12	1.5
MOV direct, R7	8F	2	2	8	12	1.5
MOV direct, @R0	86	2	2	8	12	1.5
MOV direct, @R1	87	2	2	8	12	1.5
MOV direct, direct	85	3	3	12	24	2
MOV direct, #data	75	3	3	12	24	2
MOV DPTR, #data 16	90	3	3	12	24	2
MOVC A, @A+DPTR	93	1	2	8	24	3
MOVC A, @A+PC	83	1	2	8	24	3
MOVX A, @R0	E2	1	2 - 9	8 - 36	24	3 - 0.66
MOVX A, @R1	E3	1	2 - 9	8 - 36	24	3 - 0.66
MOVX A, @DPTR	E0	1	2 - 9	8 - 36	24	3 - 0.66
MOVX @R0, A	F2	1	2 - 9	8 - 36	24	3 - 0.66
MOVX @R1, A	F3	1	2 - 9	8 - 36	24	3 - 0.66
MOVX @DPTR, A	F0	1	2 - 9	8 - 36	24	3 - 0.66
PUSH direct	C0	2	2	8	24	3
POP direct	D0	2	2	8	24	3

Preliminary N79E875 Data Sheet



Op-code	HEX Code	Bytes	N79E875 series Machine Cycle	N79E875 series Clock cycles	8032 Clock cycles	N79E875 series vs. 8032 Speed Ratio
XCH A, R0	C8	1	1	4	12	3
XCH A, R1	C9	1	1	4	12	3
XCH A, R2	CA	1	1	4	12	3
XCH A, R3	CB	1	1	4	12	3
XCH A, R4	CC	1	1	4	12	3
XCH A, R5	CD	1	1	4	12	3
XCH A, R6	CE	1	1	4	12	3
XCH A, R7	CF	1	1	4	12	3
XCH A, @R0	C6	1	1	4	12	3
XCH A, @R1	C7	1	1	4	12	3
XCHD A, @R0	D6	1	1	4	12	3
XCHD A, @R1	D7	1	1	4	12	3
XCH A, direct	C5	2	2	8	12	1.5
CLR C	C3	1	1	4	12	3
CLR bit	C2	2	2	8	12	1.5
SETB C	D3	1	1	4	12	3
SETB bit	D2	2	2	8	12	1.5
CPL C	B3	1	1	4	12	3
CPL bit	B2	2	2	8	12	1.5
ANL C, bit	82	2	2	8	24	3
ANL C, /bit	B0	2	2	6	24	3
ORL C, bit	72	2	2	8	24	3
ORL C, /bit	A0	2	2	6	24	3
MOV C, bit	A2	2	2	8	12	1.5
MOV bit, C	92	2	2	8	24	3
ACALL addr11	71, 91, B1, 11, 31, 51, D1, F1	2	3	12	24	2

Preliminary N79E875 Data Sheet



Op-code	HEX Code	Bytes	N79E875 series Machine Cycle	N79E875 series Clock cycles	8032 Clock cycles	N79E875 series vs. 8032 Speed Ratio
LCALL addr16	12	3	4	16	24	1.5
RET	22	1	2	8	24	3
RETI	32	1	2	8	24	3
AJMP ADDR11	01, 21, 41, 61, 81, A1, C1, E1	2	3	12	24	2
LJMP addr16	02	3	4	16	24	1.5
JMP @A+DPTR	73	1	2	6	24	3
SJMP rel	80	2	3	12	24	2
JZ rel	60	2	3	12	24	2
JNZ rel	70	2	3	12	24	2
JC rel	40	2	3	12	24	2
JNC rel	50	2	3	12	24	2
JB bit, rel	20	3	4	16	24	1.5
JNB bit, rel	30	3	4	16	24	1.5
JBC bit, rel	10	3	4	16	24	1.5
CJNE A, direct, rel	B5	3	4	16	24	1.5
CJNE A, #data, rel	B4	3	4	16	24	1.5
CJNE @R0, #data, rel	B6	3	4	16	24	1.5
CJNE @R1, #data, rel	B7	3	4	16	24	1.5
CJNE R0, #data, rel	B8	3	4	16	24	1.5
CJNE R1, #data, rel	B9	3	4	16	24	1.5
CJNE R2, #data, rel	BA	3	4	16	24	1.5
CJNE R3, #data, rel	BB	3	4	16	24	1.5
CJNE R4, #data, rel	BC	3	4	16	24	1.5
CJNE R5, #data, rel	BD	3	4	16	24	1.5
CJNE R6, #data, rel	BE	3	4	16	24	1.5
CJNE R7, #data, rel	BF	3	4	16	24	1.5

Preliminary N79E875 Data Sheet



Op-code	HEX Code	Bytes	N79E875 series Machine Cycle	N79E875 series Clock cycles	8032 Clock cycles	N79E875 series vs. 8032 Speed Ratio
DJNZ R0, rel	D8	2	3	12	24	2
DJNZ R1, rel	D9	2	3	12	24	2
DJNZ R5, rel	DD	2	3	12	24	2
DJNZ R2, rel	DA	2	3	12	24	2
DJNZ R3, rel	DB	2	3	12	24	2
DJNZ R4, rel	DC	2	3	12	24	2
DJNZ R6, rel	DE	2	3	12	24	2
DJNZ R7, rel	DF	2	3	12	24	2
DJNZ direct, rel	D5	3	4	16	24	1.5

Table 8-1: Instruction Set for N79E875

新唐科技 NUVOTON
INTELLECTUAL PROPERTY

9 POWER MANAGEMENT

N79E875 series are provided with idle mode and power-down mode to control power consumption. These modes are discussed in the next two sections, followed by a discussion of resets.

9.1 Idle Mode

The user can put the device into idle mode by writing 1 to the bit PCON.0. The instruction that sets the idle bit is the last instruction that will be executed before the device goes into Idle Mode. In the Idle mode, the clock to the CPU is halted, but not to the peripheral blocks. This forces the CPU state to be frozen; the Program counter, the Stack Pointer, the Program Status Word, the Accumulator and the other registers hold their contents. The port pins hold the logical states they had at the time Idle was activated. The Idle mode can be terminated in two ways. Since the interrupt controller is still active, the activation of any enabled interrupt can wake up the processor. This will automatically clear the Idle bit, terminate the Idle mode, and the Interrupt Service Routine (ISR) will be executed. After the ISR is completed, the program execution returns to the instruction after one which put the device into Idle mode and continues from there.

The Idle mode can also be exited by activating the reset. The device can put into reset either by applying a low on the external /RST pin, a Power on reset condition or a Watchdog timer reset. The external reset pin has to be held low for at least two machine cycles i.e. 8 clock periods to be recognized as a valid reset. In the reset condition the program counter is reset to 0000h and all the SFRs are set to the reset condition. Since the clock is already running there is no delay and execution starts immediately. In the Idle mode, the Watchdog timer continues to run, and if enabled, a time-out will cause a watchdog timer interrupt which will wake up the device. The software must reset the Watchdog timer in order to preempt the reset which will occur after 512 clock periods of the time-out. When N79E875series are exiting from Idle Mode with a reset, the instruction following the one which put the device into Idle Mode is not executed. So there is no danger of unexpected writes.

9.2 Power Down Mode

The device can be put into Power Down mode by writing 1 to bit PCON.1. The instruction that does this will be the last instruction to be executed before the device goes into Power Down mode. In the Power Down mode, all the clocks are stopped and the device comes to a halt. All activity, except the functions of Brownout reset, KBI, INT1, INT0, watchdog timer(Config0.WDTCK=0), ADC(RCCLK=1) and Analog Comparator(if enabled), is completely stopped and the power consumption is reduced to the lowest possible value. The port pins hold at the states of the values held by their respective SFRs.

The interrupt sources that can wake up CPU from the power down mode **are external interrupts, keyboard interrupt (KBI), brownout reset (BOR), comparators interrupt(CMF1/CMF2), ADC interrupt(if ADC clock is from internal RC) and watchdog timer interrupt (if WDTCK = 0)**. The device will then execute the interrupt service routine for the corresponding external interrupt. After the interrupt service routine is completed, the program execution returns to the instruction after one which put the device into Power Down mode and continues from there.

Besides, the /RST pin trigger by a low pulse of at least two machine cycle terminates the Power Down mode and restarts the clock. The program execution will restart from 0000h.

Note:

1. Either a **low-level or a falling-edge at external interrupt pins /INT0 and INT1** will re-start the oscillator if the global interrupt is enabled(EA=1) and the corresponding interrupt is enabled.
2. **The /INT0 pin is permanently in open-drain type therefore it is recommended with an external pull-up resistor on pin in application**



10 RESET CONDITIONS

The user has several hardware related options for placing N79E875 series into reset condition. In general, most register bits go to their reset value irrespective of the reset condition, but there are a few flags whose state depends on the source of reset. The user can use these flags to determine the cause of reset using software. The sources of resets are external reset, power-on-reset, watchdog timer reset and software reset (brownout is also able to reset the device if enabled).

10.1 External Reset

The device continuously samples the /RST pin at state C4 of every machine cycle. Therefore the /RST pin must be held low for at least 2 machine cycles to ensure detection of a valid /RST low. The reset circuitry then synchronously applies the internal reset signal. Thus the reset is a synchronous operation and requires the clock to be running to cause an external reset.

Once the device is in reset condition, it will remain so as long as /RST is 0. Even after /RST is deactivated, the device will continue to be in reset state for up to two machine cycles, and then begin program execution from 0000h. There is no flag associated with the external reset condition. However since the other two reset sources have flags, the external reset can be considered as the default reset if those two flags are cleared.

10.2 Power-On Reset (POR)

When power up, the device performs a power-on reset and sets the POR flag. The software should clear the POR flag, or it will be difficult to determine the source of future resets. During power-on-reset, all port pins will be tri-stated. After power-on-reset, the port pins state will be determined by PRHI value.

10.3 Watchdog Timer Reset

The Watchdog timer is a free running timer with programmable time-out intervals. The user can clear the watchdog timer at any time, causing it to restart the count. When the time-out interval is reached an interrupt flag (WDIF at WDCON.3) will be set by hardware. If the Watchdog reset is enabled (WDRUN at WDCON.7) and the watchdog timer is not cleared before the time-out of 512 clock period since WINTF is set, the watchdog timer will set watchdog reset flag (WTRF at WDCON.2) and generate a reset. This places the device into the reset condition. The reset condition is maintained by hardware for two machine cycles. Once the reset is removed the device will begin execution from 0000h. The watchdog reset flag WTRF keeps high after watchdog reset, it must be cleared by software.

10.4 Software Reset

User can software reset the device by setting SRST bit in SFR AUXR1. The reset condition is maintained by hardware for two machine cycles. Once the reset is removed the device will begin execution from 0000h. **User must specially take care of setting SRST when a write access on AUXR1.**

10.5 Brownout Reset

When the power voltage (V_{DD}) is lower than brownout voltage (V_{BOD}), the brownout detector will set brownout interrupt flag (BOF at PCON.5), if brownout reset function is enabled ($BOD=1$ and $BOI=0$ at AUXR1) a hardware brownout reset will be triggered and the device keeps in reset state until the V_{DD} raises above brownout voltage. Note that BOF won't be cleared by brownout reset, it must be cleared by software

10.6 Reset State

Most of the SFRs and registers on the device will go to the same condition in the reset state. The Program Counter is forced to 0000h and is held there as long as the reset condition is applied. However, the reset state does not affect the on-chip RAM. The data in the RAM will be preserved during the reset. However, the stack pointer is reset to 07h, and therefore the stack contents will be lost. The RAM contents will be lost if the V_{DD} falls below approximately 2V, as this is the minimum voltage level required for the RAM data retention. Therefore after a first time power on reset the RAM contents will be indeterminate. During a power fail condition, if the power falls below 2V, the RAM contents are lost.

The WDCON SFR bits are set/cleared in reset condition depending on the source of the reset. The WDCON SFR is set to a 0x00 0000B on the reset. WTRF (WDCON.2) is set to a 1 on a Watchdog timer reset, but to a 0 on power on/down resets. WTRF (WDCON.2) is not altered by external reset. EWRST (WDCON.1) is cleared by any reset. Software or any reset will clear WDIF (WDCON.3) bit.

Some of the bits in the WDCON SFR (WDRUN, WDCLR, EWRST, WDIF, WD0 and WD1) have unrestricted read access which required Timed Access procedure to write. The remaining bits have unrestricted write accesses. Please refer TA register description.

The WDCON SFR bits are set or cleared in reset condition depending on the source of the reset.

WDCON	Watch-Dog control	D8H	(DF) WDRUN	(DE) -	(DD) WD1	(DC) WD0	(DB) WDIF	(DA) WTRF	(D9) EWRST	(D8) WDCLR	External reset: 0x00 0x00b Watchdog reset: 0x00 0100b Power on reset 0x00 0000b
-------	-------------------	-----	---------------	-----------	-------------	-------------	--------------	--------------	---------------	---------------	---

新唐科技 NUVOTON
INTELLECTUAL PROPERTY



11 INTERRUPTS

N79E875 series have four priority level interrupts structure with 17 interrupt sources. Each of the interrupt sources has an individual priority bit, flag, interrupt vector and enable bit. In addition, the interrupts can be globally enabled or disabled.

11.1 Interrupt Sources

The External Interrupts $\overline{\text{INT0}}$ and $\overline{\text{INT1}}$ can be either edge triggered or level triggered, programmable through bits IT0 and IT1 (SFR TCON). The bits IE0 and IE1 in TCON register are the flags which are checked to generate the interrupt. In the edge triggered mode, the INTx inputs are sampled in every machine cycle. If the sample is high in one cycle and low in the next, then a high to low transition is detected and the interrupts request flag IEx in TCON is set. The flag bit requests the interrupt. Since the external interrupts are sampled every machine cycle, they have to be held high or low for at least one complete machine cycle. The IEx flag is automatically cleared when the service routine is called. If the level triggered mode is selected, then the requesting source has to hold the pin low till the interrupt is serviced. The IEx flag will not be cleared by the hardware on entering the service routine. If the interrupt continues to be held low even after the service routine is completed, then the processor may acknowledge another interrupt request from the same source.

The Timer 0 and 1 Interrupts are generated by the TF0 and TF1 flags. These flags are set by the overflow in the Timer 0 and Timer 1. The TF0 and TF1 flags are automatically cleared by the hardware when the timer interrupt is serviced. The Watchdog timer can be used as a system monitor or a simple timer. In either case, when the time-out count is reached, the Watchdog Timer interrupt flag WDIF (WDCON.3) is set. If the interrupt is enabled by the enable bit EIE14, then an interrupt will occur.

The timer 2 interrupt is generated through TF2 (due timer 2 overflows or compare match events). The flag must be software cleared.

The timer 3 interrupt is generated through TF3 (due to timer 3 overflows, compare match or capture events). The flag must be software cleared.

The Watchdog timer can be used as a system monitor or a simple timer. In either case, when the time-out count is reached, the Watchdog Timer interrupt flag WDIF (WDCON.3) is set. If the interrupt is enabled by the enable bit EIE14, then an interrupt will occur.

The capture interrupt is generated through logical OR CPTF0-2 flags. CPTF0-2 flags are set by capture/reload events. Software has to resolve the cause of the interrupt among CPTF0-2. The flags must be software cleared.

The Serial block can generate interrupt on reception or transmission. There are two interrupt sources from the Serial block, which are obtained by the RI and TI bits in the SCON SFR. The flag must be software cleared.

I2C will generate an interrupt due to a new SIO state present in I2STATUS register, if both EA and ES bits (in IE register) are both enabled.

SPI asserts interrupt flag, SPIF, upon completion of data transfer with an external device. If SPI interrupt is enabled (ESPI at EIE2.3), a serial peripheral interrupt is generated. SPIF flag is software clear, by writing a 0. MODF and SPIOVF also will generate interrupt if occur. They share the same vector address as SPIF.

Keyboard interrupt is generated when any of the keypad connected to P0 pins is pressed. Each keypad interrupt can be individually enabled or disabled. The flag must be cleared by software.

Comparators 1 and 2 can generate interrupts when detected change in any of the comparator output. CMF1 or CMF2 flag will be asserted, accordingly. The flags must be cleared by software.

PWM period interrupt flag PWMF is set by hardware when its' 12-bit counter underflows/match and is

only be cleared by software. The PWM brake interrupt flag0 FBK0 is set when the external brake pin0(BKP0) detects a falling edge if BKEN0 is enabled. Alternatively, the brake interrupt flag1 FBK1 is set by the external brake pin1(BKP1) detecting a falling change if BKEN1 is enabled.

The ADC can generate interrupt after finished ADC converter. There are two ADC interrupt sources; one is obtained by the ADCI bit in the ADCCON SFR and another from ADCPI bit in ADCRL SFR. The flags must be software cleared.

Brownout detect can cause brownout flag, BOF, to be asserted if power voltage drop below brownout voltage level. Interrupt will occur if BOI (AUXR1.5), EBO (IE.5) and global interrupt enable are set.

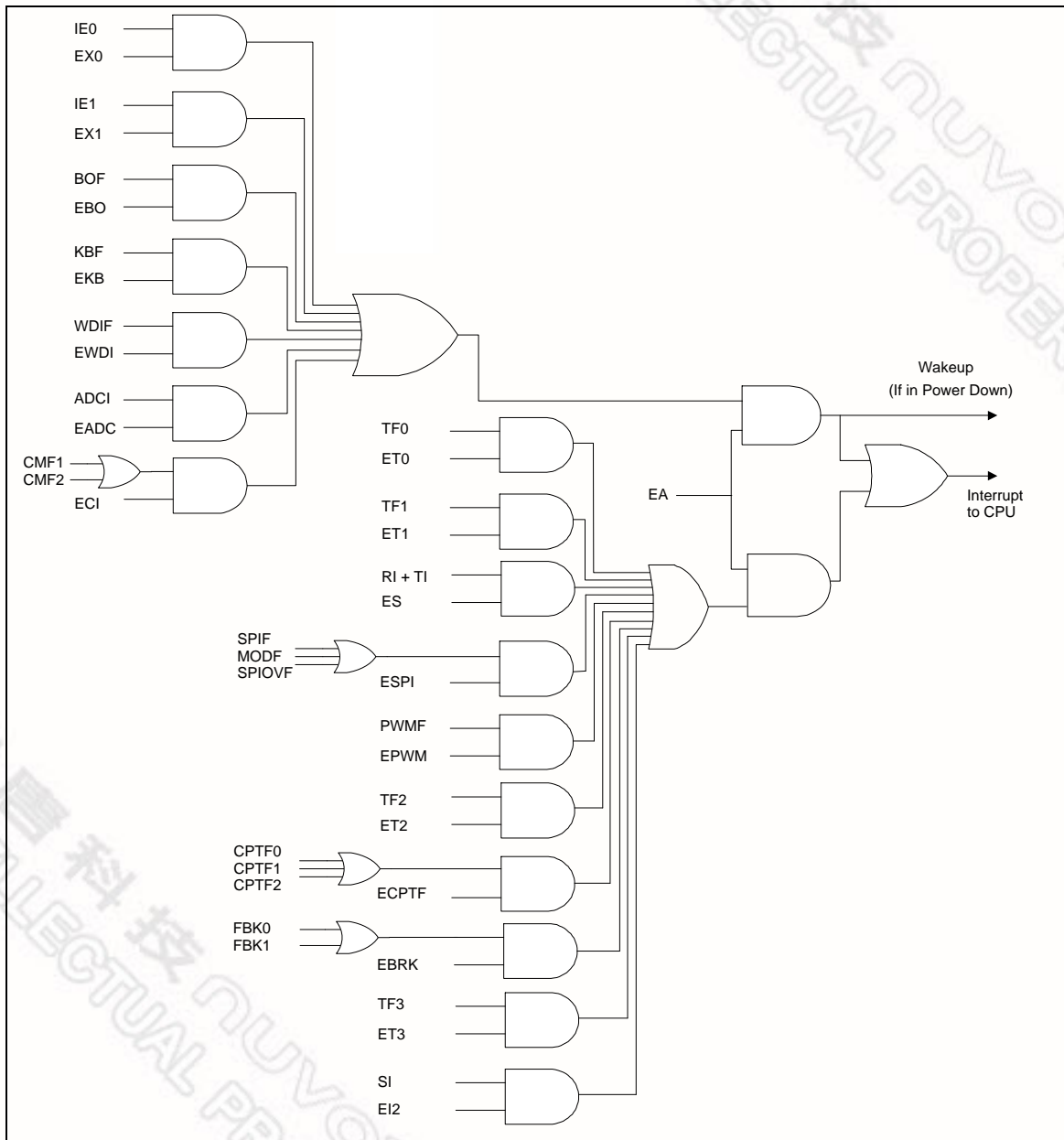

Figure 11-1 Interrupt Source



11.2 Priority Level Structure

There are four priority levels for the interrupts, highest, high, low and lowest. The interrupt sources can be individually set to either high or low levels. Naturally, a higher priority interrupt cannot be interrupted by a lower priority interrupt. However there exists a pre-defined hierarchy amongst the interrupts themselves. This hierarchy comes into play when the interrupt controller has to resolve simultaneous requests having the same priority level. This hierarchy is defined as shown on Table 11-1 Four-level interrupts priority.

The interrupt flags are sampled every machine cycle. In the same machine cycle, the sampled interrupts are polled and their priority is resolved. If certain conditions are met then the hardware will execute an internally generated LCALL instruction which will vector the process to the appropriate interrupt vector address. The conditions for generating the LCALL are;

1. An interrupt of equal or higher priority is not currently being serviced.
2. The current polling cycle is the last machine cycle of the instruction currently being execute.
3. The current instruction does not involve a write to IE, EIE, EIE2, IP0, IP0H, IP1, IPH1, IP2 or IP2H registers and is not a RETI.

If any of these conditions are not met, then the LCALL will not be generated. The polling cycle is repeated every machine cycle, with the interrupts sampled in the same machine cycle. If an interrupt flag is active in one cycle but not responded to, and is not active when the above conditions are met, the denied interrupt will not be serviced. This means that active interrupts are not remembered; every polling cycle is new.

The processor responds to a valid interrupt by executing an LCALL instruction to the appropriate service routine. This may or may not clear the flag which caused the interrupt. In case of Timer interrupts, the TF0 or TF1 flags are cleared by hardware whenever the processor vectors to the appropriate timer service routine. In case of external interrupt, /INT0 and /INT1, the flags are cleared only if they are edge triggered. In case of Serial interrupts, the flags are not cleared by hardware. In the case of Timer 2 interrupt, the flags are not cleared by hardware. The Watchdog timer interrupt flag WDIF has to be cleared by software. The hardware LCALL behaves exactly like the software LCALL instruction. This instruction saves the Program Counter contents onto the Stack, but does not save the Program Status Word PSW. The PC is reloaded with the vector address of that interrupt which caused the LCALL. These address of vector for the different sources are as shown on Table 11-2 Summary of interrupt sources. The vector table is not evenly spaced; this is to accommodate future expansions to the device family.

Execution continues from the vectored address till an RETI instruction is executed. On execution of the RETI instruction the processor pops the Stack and loads the PC with the contents at the top of the stack. The user must take care that the status of the stack is restored to what it was after the hardware LCALL, if the execution is to return to the interrupted program. The processor does not notice anything if the stack contents are modified and will proceed with execution from the address put back into PC. Note that a RET instruction would perform exactly the same process as a RETI instruction, but it would not inform the Interrupt Controller that the interrupt service routine is completed, and would leave the controller still thinking that the service routine is underway.

N79E875 series use a four priority level interrupt structure. This allows great flexibility in controlling the handling of the interrupt sources.

PRIORITY BITS		INTERRUPT PRIORITY LEVEL
IPxH	IPx	
0	0	Level 0 (lowest priority)

0	1	Level 1
1	0	Level 2
1	1	Level 3 (highest priority)

Table 11-1 Four-level interrupts priority

Each interrupt source can be individually enabled or disabled by setting or clearing a bit in registers IE, EIE or EIE2. The IE register also contains a global disable bit, EA, which disables all interrupts at once.

Each interrupt source can be individually programmed to one of four priority levels by setting or clearing bits in the IP0, IP0H, IP1, IP1H, IP2 and IP2H registers. An interrupt service routine in progress can be interrupted by a higher priority interrupt, but not by another interrupt of the same or lower priority. The highest priority interrupt service cannot be interrupted by any other interrupt source. So, if two requests of different priority levels are received simultaneously, the request of higher priority level is serviced.

If requests of the same priority level are received simultaneously, an internal polling sequence determines which request is serviced. This is called the arbitration ranking. Note that the arbitration ranking is only used to resolve simultaneous requests of the same priority level.

Table below summarizes the interrupt sources, flag bits, vector addresses, enable bits, priority bits, arbitration ranking, and whether each interrupt may wake up the CPU from Power Down mode.

Source	Flag	Vector addresses	Enable bit	Flag cleared by	Priority bit	Arbitration ranking	Power-down wakeup
External Interrupt 0	IE0	0003H	EX0 (IE.0)	Hardware, Software	IP0H.0, IP0.0	1(highest)	Yes
Brownout Detect	BOF	002BH	EBO (IE.5)	Hardware	IP0H.5, IP0.5	2	Yes
Watchdog Timer	WDIF	0053H	EWDI (EIE14)	Software	IP1H.4, IP1.4	3	Yes ^[1]
Timer 0 Overflow	TF0	000BH	ET0 (IE.1)	Hardware, Software	IP0H.1, IP0.1	4	No
SPI	SPIF + MODF + SPIOVF	004BH	ESPI (EIE2.3)	Software	IP2H.3, IP2.3	5	No
I2C	SI	0033H	EI2C (EIE1.0)	Software	IP1H.0, IP1.0	6	No
A/D Converter	ADC1+ ADCPI	005BH	EADC (IE.6) + EADCP (EIE2.1)	Software	IP0H.6, IP0.6	7	Yes ^[2]
External	IE1	0013H	EX1	Hardware,	IP0H.2,	8	Yes



Interrupt 1			(IE.2)	Software	IP0.2		
KBI	KBF	003BH	EKB (EIE1.1)	Software	IP1H.1, IP1.1	9	Yes
Comparator 1 & 2	CMF1+ CMF2	0063H	ECI (EIE1.2)	Software	IP1H.2, IP1.2	10	Yes
Timer Overflow 1	TF1	001BH	ET1 (IE.3)	Hardware, Software	IP0H.3, IP0.3	11	No
Serial Port	RI + TI	0023H	ES (IE.4)	Software	IP0H.4, IP0.4	12	No
Timer Overflow/ Match 2	TF2	007BH	ET2 (EIE2.6)	Software	IP2H.6, IP2.6	13	No
PWM brake	FBK0, FBK1	0083H	EBRK (EIE1.5)	Software	IP1H.2, IP1.2	14	No
Capture	CPTF0-2	006BH	ECPTF (EIE1.7)	Software	IP1H.7, IP1.7	15	No
Timer Overflow/ Match/ Capture 3	TF3	008BH	ET3 (EIE2.0)	Software	IP2H.0, IP2.0	16	No
PWM match/ underflow	PWMF	0073H	EPWM (EIE1.6)	Software	IP1H.5, IP1.5	17 (lowest)	No

Table 11-2 Summary of interrupt sources

Note:

The Watchdog Timer can wake up Power Down Mode when its clock source is used internal RC.

ADC Converter interrupt source, ADCI, can wake up Power Down Mode when its clock source is used internal RC. However, ADC compare interrupt source, ADCPI, is not able to wake up from Power Down Mode.

11.3 Interrupt Response Time

The response time for each interrupt source depends on several factors, such as the nature of the interrupt and the instruction underway. In the case of external interrupts $\overline{INT0}$ and $\overline{INT1}$, they are sampled at C3 of every machine cycle and then their corresponding interrupt flags IEx will be set or reset. The Timer 0 and 1 overflow flags are set at C3 of the machine cycle in which overflow has occurred. These flag values are polled only in the next machine cycle. If a request is active and all three conditions are met, then the hardware generated LCALL is executed. This LCALL itself takes four machine cycles to be completed. Thus there is a minimum time of five machine cycles between the interrupt flag being set and the interrupt service routine being executed.

A longer response time should be anticipated if any of the three conditions are not met. If a higher or equal priority is being serviced, then the interrupt latency time obviously depends on the nature of the service routine currently being executed. If the polling cycle is not the last machine cycle of the instruction being executed, then an additional delay is introduced. The maximum response time (if no other interrupt is in service) occurs if the device is performing a write to IE, EIE1, EIE2, IP0, IP0H, IP1, IP1H, IP2 or IP2H and then executes a MUL or DIV instruction. From the time an interrupt source is activated, the longest reaction time is 12 machine cycles. This includes 1 machine cycle to detect the interrupt, 2 machine cycles to complete the IE, EIE1, EIE2, IP0, IP0H, IP1, IP1H, IP2 or IP2H access, 5 machine cycles to complete the MUL or DIV instruction and 4 machine cycles to complete the hardware LCALL to the interrupt vector location.

Thus in a single-interrupt system the interrupt response time will always be more than 5 machine cycles and not more than 12 machine cycles. The maximum latency of 12 machine cycle is 48 clock cycles. Note that in the standard 8051 the maximum latency is 8 machine cycles which equals 96 machine cycles. This is a 50% reduction in terms of clock periods.

12 NVM MEMORY

The N79E875 series have NVM data memory of **128** bytes for customer's data store used. The NVM data memory has **8** pages area and each page has **16** bytes. The page addresses are shown on Figure 12-1.

The NVM memory can be read/write by customer program to access. Read NVM data is by MOVC A,@A+DPTR instruction, and write data is by SFR of NVMADDRL, NVMDAT and NVMCON. Before write data to NVM memory, the page must be erased by providing page address on NVMADDRL, which high and low byte address of On-Chip Code Memory space will decode, then set EER of NVMCON.7. This will automatically hold fetch program code and PC Counter, and execute page erase. After finished, this bit will be cleared by hardware. The **erase time is ~ 5ms**.

For writing data to NVM memory, user must set address and data to NVMADDRL and NVMDAT, then set EWR of NVMCON.6 to initiate NVM data write. The uC will hold program code and PC Counter, and then write data to mapping address. Upon write completion, the EWR bit will be cleared by hardware, the uC will continue execute next instruction. The **program time is ~50us**.

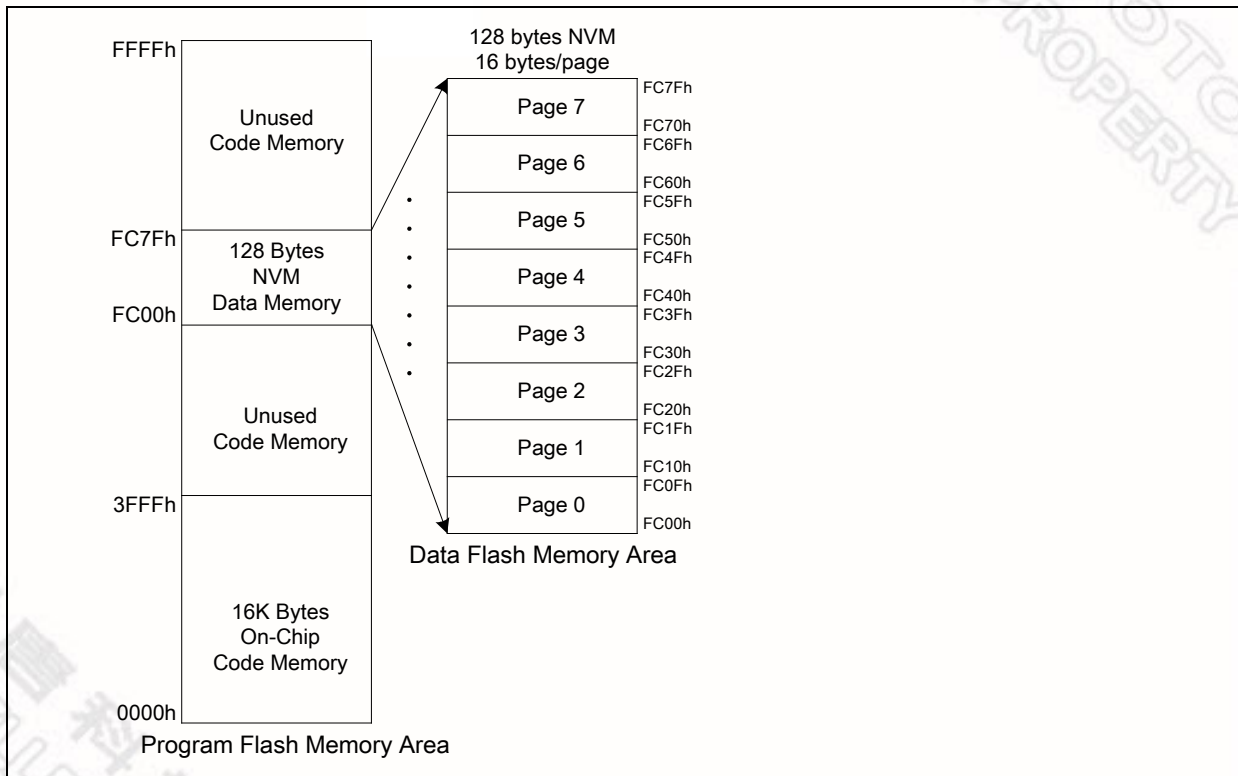

Figure 12-1 N79E875 On-chip Flash Memory Space

13 PROGRAMMABLE TIMERS/COUNTERS

The N79E875 series have two 16-bit programmable timer/counters which have additional timer 0 or timer 1 overflow toggle output enable feature as compare to conventional timer/counters. This timer overflow toggle output can be configured to automatically toggle T0 or T1 pin output whenever a timer overflow occurs.

13.1 TIMER/COUNTERS 0 & 1

N79E875 series have two 16-bit Timer/Counters. Each of these Timer/Counters has two 8 bit registers which form the 16 bit counting register. For Timer/Counter 0 they are TH0, the upper 8 bits register, and TL0, the lower 8 bit register. Similarly Timer/Counter 1 has two 8 bit registers, TH1 and TL1. The two can be configured to operate either as timers, counting machine cycles or as counters counting external inputs.

When configured as a "Timer", the timer counts clock cycles. For timer 0, the timer clock can be programmed to be thought of as 1/12 of the system clock or 1/4, 1/16, 1/32, 1/128 (selectable through SFR DIV.TODIV bits) of the system clock. As for timer 1, the timer clock can be programmed to be thought of as 1/12 of the system clock or 1/4 of the system clock. In the "Counter" mode, the register is incremented on the falling edge of the external input pin, T0 in case of Timer 0, and T1 for Timer 1. The T0 and T1 inputs are sampled in every machine cycle at C4. If the sampled value is high in one machine cycle and low in the next, then a valid high to low transition on the pin is recognized and the count register is incremented. Since it takes two machine cycles to recognize a negative transition on the pin, the maximum rate at which counting will take place is 1/24 of the master clock frequency. In either the "Timer" or "Counter" mode, the count register will be updated at C3. Therefore, in the "Timer" mode, the recognized negative transition on pin T0 and T1 can cause the count register value to be updated only in the machine cycle following the one in which the negative edge was detected.

The "Timer" or "Counter" function is selected by the "C/T" bit in the TMOD Special Function Register. Each Timer/Counter has one selection bit for its own; bit 2 of TMOD selects the function for Timer/Counter 0 and bit 6 of TMOD selects the function for Timer/Counter 1. In addition each Timer/Counter can be set to operate in any one of four possible modes. The mode selection is done by bits M0 and M1 in the TMOD SFR.

13.2 Time-Base Selection

N79E875 series provide users with two modes of operation for the timer. The timers can be programmed to operate like the standard 8051 family, counting at the rate of 1/12 of the clock speed. This will ensure that timing loops on N79E875 series and the standard 8051 can be matched. This is the default mode of operation of the N79E875 series timers. The user also has the option to count in the turbo mode, where the timers will increment at the rate of 1/4 clock speed (timer 1) or rate of 1/4, 1/16, 1/32, 1/128 clock speed (timer 0). This will straight-away increase the counting speed up to three times. This selection is done by the T0M and T1M bit in CKCON SFR, and TODIV bits in DIV SFR. A reset sets these bits to 0, and the timers then operate in the standard 8051 mode. The user should set these bits accordingly if the timers are to operate in turbo mode.

13.3 MODE 0

In Mode 0, the timer/counters act as an 8-bit counter with a 5-bit, divide by 32 pre-scale. In this mode we have a 13-bit timer/counter. The 13-bit counter consists of 8 bits of THx and 5 lower bits of TLx. The upper 3 bits of TLx are ignored.

The negative edge of the clock is increments count in the TLx register. When the fifth bit in TLx moves from 1 to 0, then the count in the THx register is incremented. When count in THx moves from FFh to 00h, then the overflow flag TFx in TCON SFR is set. The counted input is enabled only if TRx is set and either GATE = 0 or INTx = 1. When C/T is set to 0, then it will count clock cycles, and if C/T is

set to 1, then it will count 1 to 0 transitions on T0 (P1.5) for timer 0 and T1 (P2.7) for timer 1. When the 13-bit count reaches 1FFFh the next count will cause it to roll-over to 0000h. The timer overflow flag TFx of the relevant timer is set and if enabled an interrupts will occur.

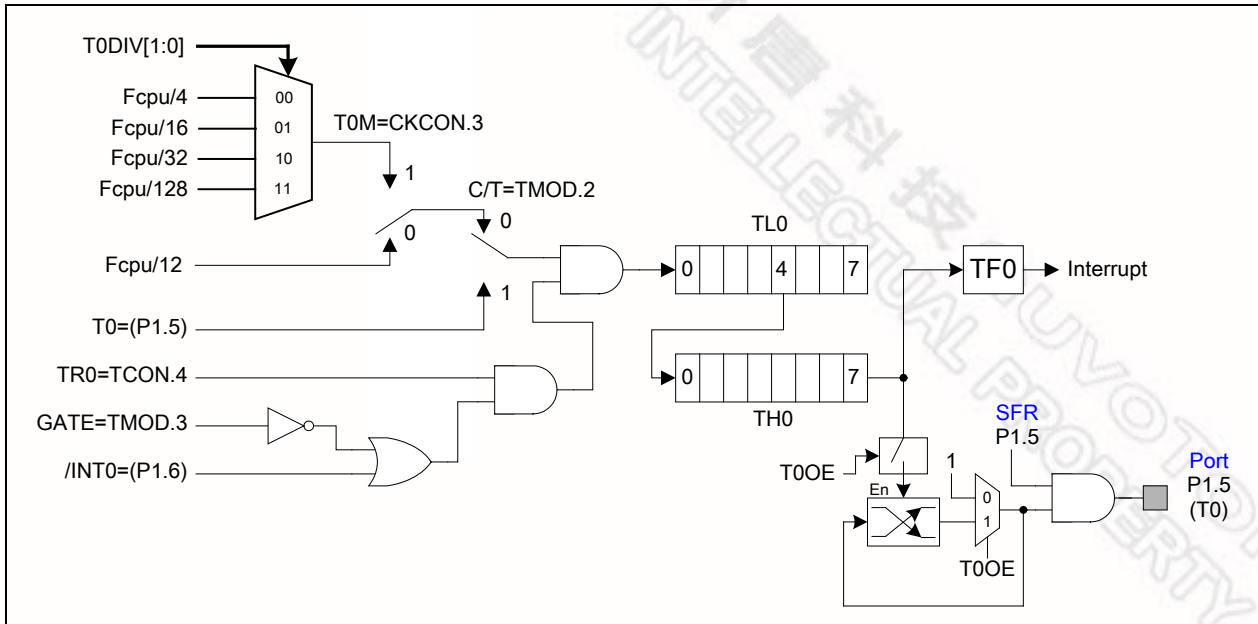

Figure 13-1 Timer 0 Mode 0

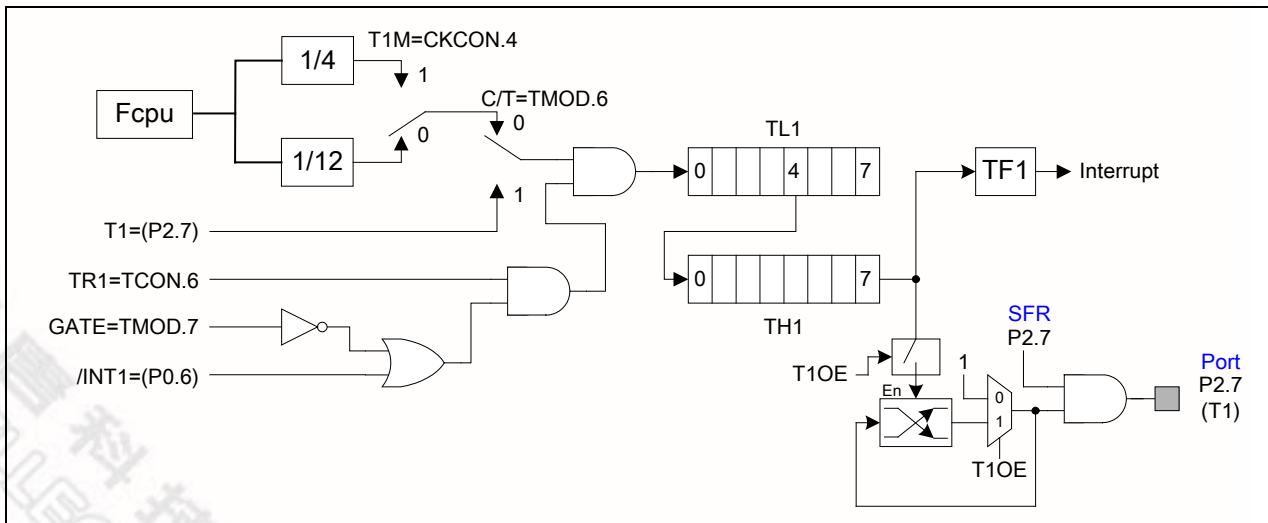

Figure 13-2 Timer 1 Mode 0

13.4 MODE 1

Mode 1 is similar to Mode 0 except that the counting register forms a 16-bit counter, rather than a 13-bit counter. This means that all the bits of THx and TLx are used. Roll-over occurs when the timer moves from a count of FFFFh to 0000h. The timer overflow flag TFx of the relevant timer is set and if enabled an interrupt will occur. The selection of the time-base in the timer mode is similar to that in Mode 0. The gate function operates similarly to that in Mode 0.

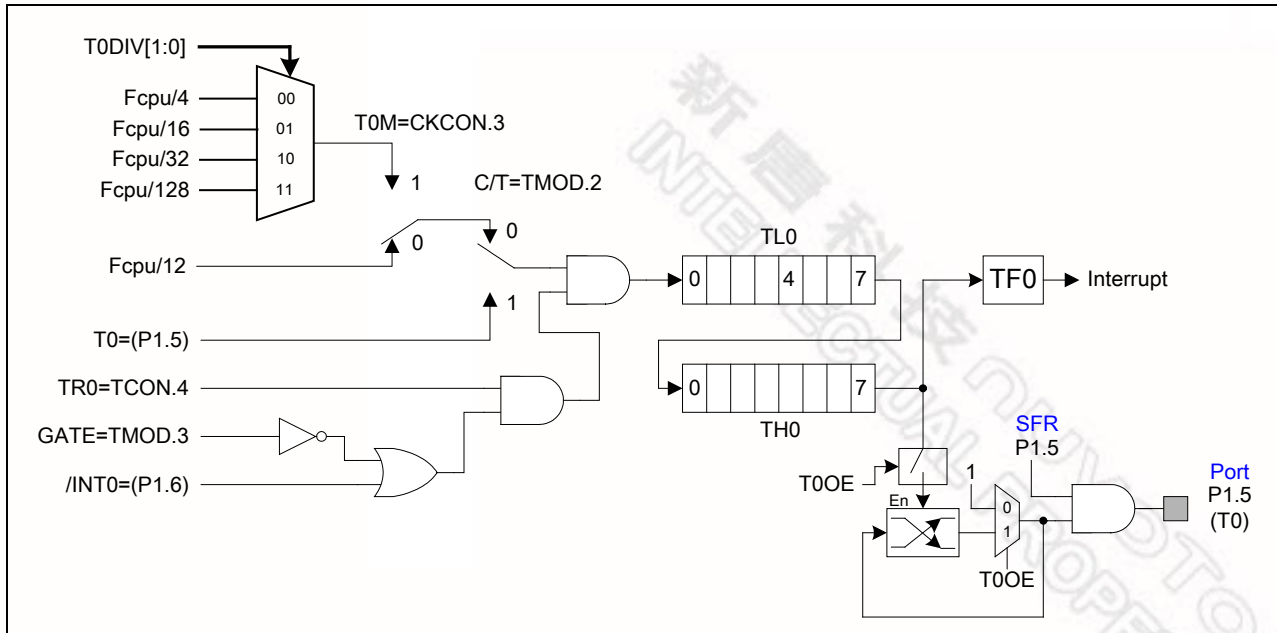

Figure 13-3 Timer 0 Mode 1

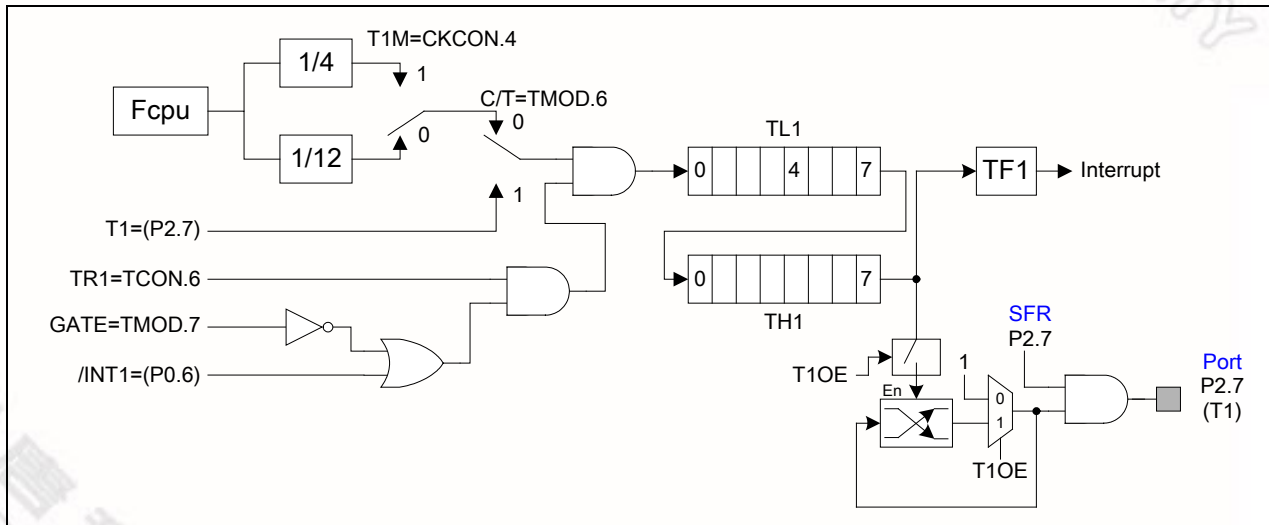

Figure 13-4 Timer 1 Mode 1

13.5 MODE 2

In Mode 2, the timer/counter is in the Auto Reload Mode. In this mode, TL_x acts as an 8-bit count register, while TH_x holds the reload value. When the TL_x register overflows from FFh to 00h, the TF_x bit in TCON is set and TL_x is reloaded with the contents of TH_x, and the counting process continues from here. The reload operation leaves the contents of the TH_x register unchanged. Counting is enabled by the TR_x bit and proper setting of GATE and INT_x pins. As in the other two modes 0 and 1, mode 2 allows counting of either clock cycles or pulses on pin T_n.

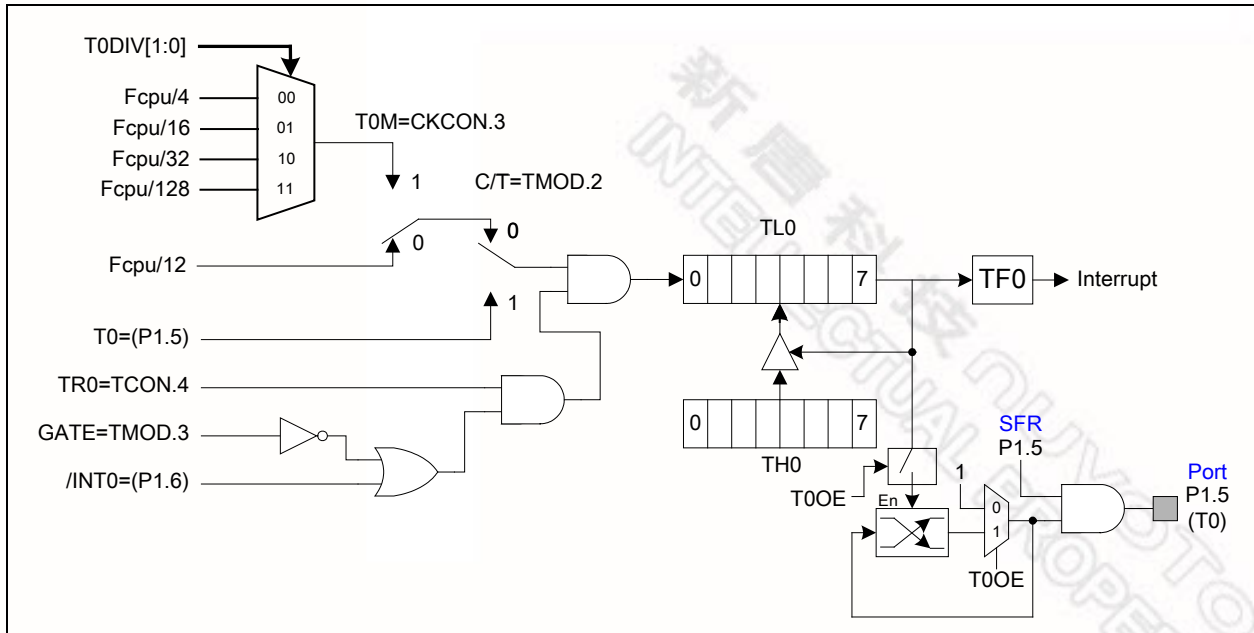

Figure 13-5 Timer 0 Mode 2 (8-bit Auto-reload Mode)

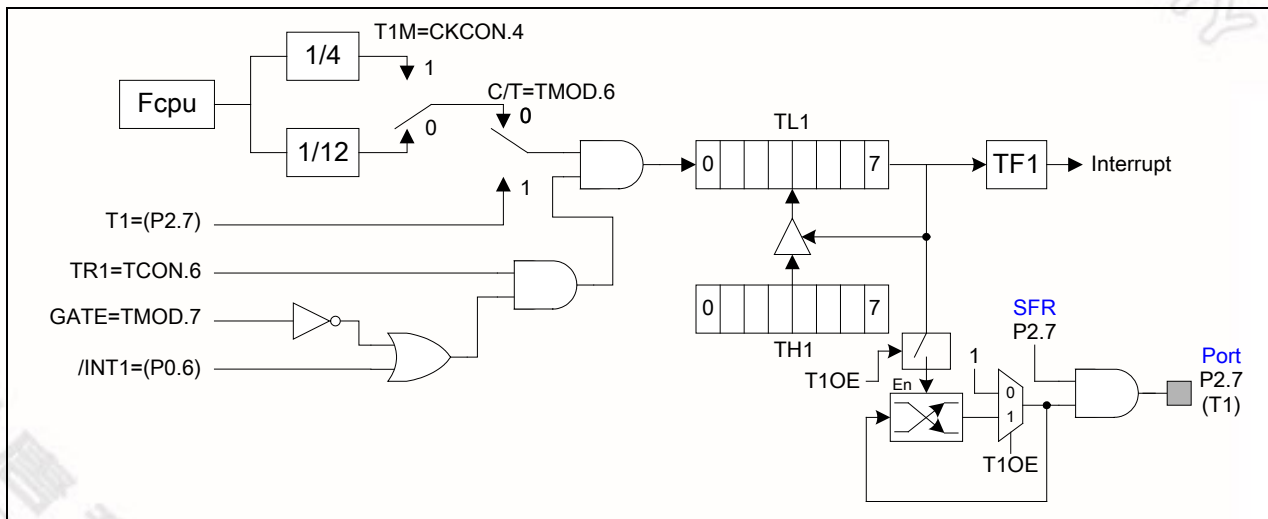

Figure 13-6 Timer 1 Mode 2 (8-bit Auto-reload Mode)

13.6 MODE 3

Mode 3 has different operating methods for the two timer/counters. For timer/counter 1, mode 3 simply freezes the counter. Timer/Counter 0, however, configures TL0 and TH0 as two separate 8 bit count registers in this mode. TL0 uses the Timer/Counter 0 control bits $\overline{C/T}$, GATE, TR0, $\overline{INT0}$ and TF0. When timer 0 configure to mode 3, the TL0 can be used to count clock cycles (clock/12 or clock/4,16,32,128) or 1-to-0 transitions on pin T0 as determined by $\overline{C/T}$ (TMOD.2). TH0 is forced as a clock cycle counter (clock/12 or clock/4,16,32,128) and takes over the use of TR1 and TF1 from Timer/Counter 1. Mode 3 is used in cases where an extra 8 bit timer is needed. With Timer 0 in Mode 3, Timer 1 can still be used in Modes 0-2, but its flexibility is somewhat limited. While its basic functionality is maintained, it no longer has control over its overflow flag TF1 and the enable bit TR1.

Timer 1 can still be used as a timer/counter and retains the use of GATE and INT1 pin. In this condition it can be turned on and off by switching it out of and into its own Mode 3. It can also be used as a baud rate generator for the serial port.

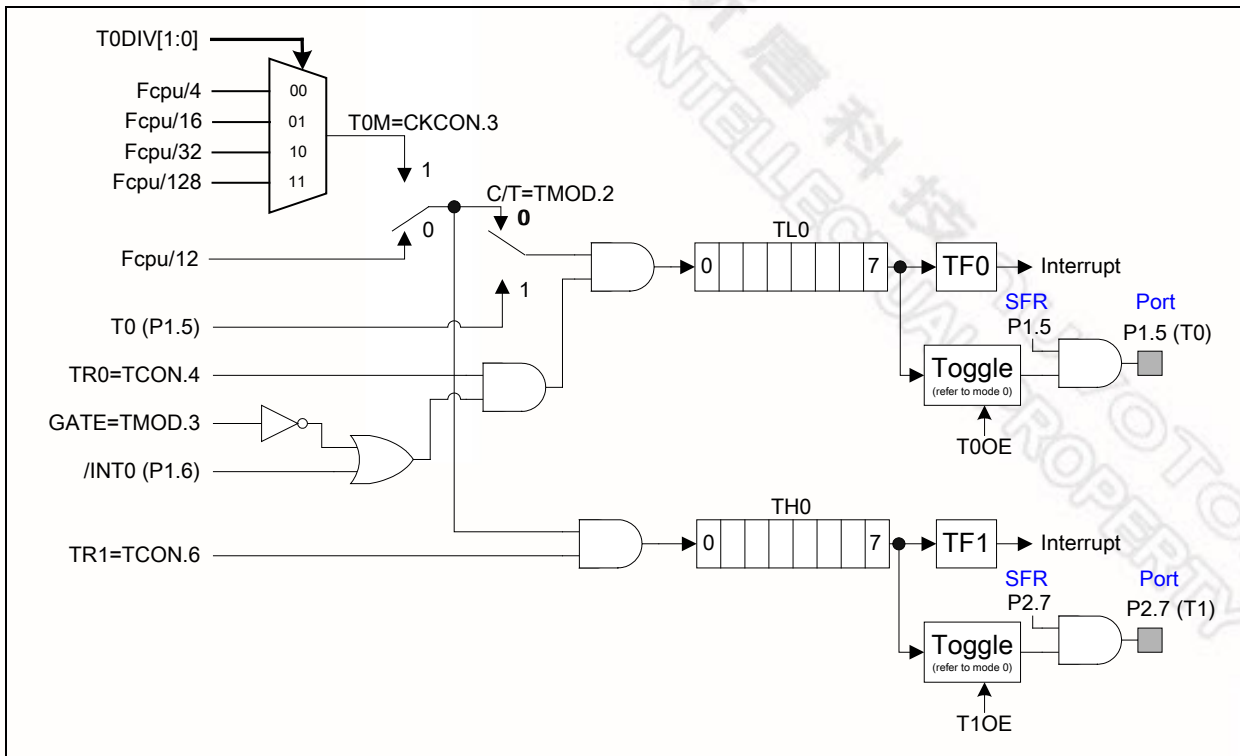

Figure 13-7 Timer 0 Mode 3 (Two 8-bit Counters)

14 WATCHDOG TIMER

The Watchdog Timer is a free-running Timer which can be programmed by the user to serve as a system monitor, a time-base generator or an event timer. It is basically a set of dividers that divide the system clock. The divider output is selectable and determines the time-out interval. When the time-out occurs a flag is set and WDT interrupt is requested if WDT interrupt is enabled (EIE.EWDI=1) and global interrupt is enabled (EA=1), and a system reset can also be caused if it is enabled. The interrupt and reset functions are independent of each other and may be used separately or together depending on the user's software.

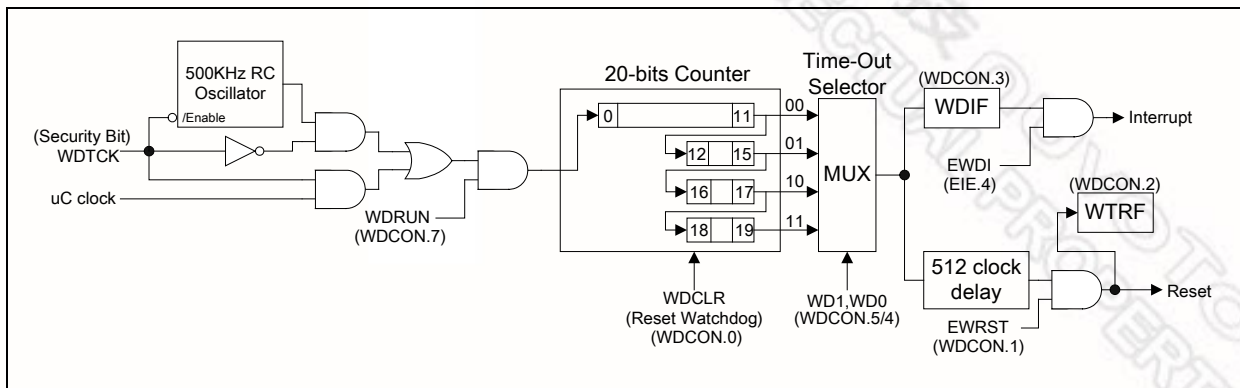

Figure 14-1 Watchdog Timer

The Watchdog Timer should first be restarted by using WDCLR. This ensures that the timer starts from a known state. The WDCLR bit is used to restart the Watchdog Timer. This bit is self clearing, i.e. after writing a 1 to this bit the hardware will automatically clear it. The Watchdog Timer will now count clock cycles. The time-out interval is selected by the two bits WD1 and WD0 (WDCON.5 and WDCON.4). When the selected time-out occurs, the Watchdog interrupt flag WDIF (WDCON.3) is set. After the time-out has occurred, the Watchdog Timer waits for an additional 512 clock cycles. If the Watchdog Reset EWRST (WDCON.1) is enabled, then 512 clocks after the time-out, if there is no WDCLR, a system reset due to Watchdog Timer will occur. This will last for two machine cycles, and the Watchdog Timer reset flag WTRF (WDCON.2) will be set. This indicates to the software that the Watchdog was the cause of the reset.

When used as a simple timer, the reset and interrupt functions are disabled. The timer will set the WDIF flag each time the timer completes the selected time interval. The WDIF flag is polled to detect a time-out and the WDCLR allows software to restart the timer. The Watchdog Timer can also be used as a very long timer. The interrupt feature is enabled in this case. Every time the time-out occurs an interrupt will occur if the global interrupt enable EA is set.

The main use of the Watchdog Timer is as a system monitor. This is important in real-time control applications. In case of some power glitches or electro-magnetic interference, the processor may begin to execute errant code. If this is left unchecked the entire system may crash. Using the watchdog timer interrupt during software development will allow the user to select ideal watchdog reset locations. The code is first written without the watchdog interrupt or reset. Then the Watchdog interrupt is enabled to identify code locations where interrupt occurs. The user can now insert instructions to reset the Watchdog Timer, which will allow the code to run without any Watchdog Timer interrupts. Now the Watchdog Timer reset is enabled and the Watchdog interrupt may be disabled. If any errant code is executed now, then the reset Watchdog Timer instructions will not be executed at the required instants and Watchdog reset will occur.

The Watchdog Timer time-out selection will result in different time-out values depending on the clock

speed. The reset will occur, when enabled, 512 clocks after the time-out has occurred.

WD1	WD0	WATCHDOG INTERVAL	NUMBER OF CLOCKS	TIME @ 10 MHZ
0	0	2^{12}	4096	0.4096 mS
0	1	2^{16}	65536	6.5536 mS
1	0	2^{18}	262144	26.2144 mS
1	1	2^{20}	1048576	104.8576 mS

Table 14-1 Time-out values for the Watchdog timer.

The Watchdog Timer will be disabled by a power-on/fail reset. The Watchdog Timer reset does not disable the Watchdog Timer, but will restart it. In general, software should restart the timer to put it into a known state. The control bits that support the Watchdog Timer are discussed on the following section.

14.1 WATCHDOG CONTROL

Bit: 7 6 5 4 3 2 1 0

WDRUN	-	WD1	WD0	WDIF	WTRF	EWRST	WDCLR
-------	---	-----	-----	------	------	-------	-------

WDIF: WDCON.3 - Watchdog Timer Interrupt flag. This bit is set whenever the time-out occurs in the Watchdog Timer. If the Watchdog interrupt is enabled (EIE14), then an interrupt will occur (if the global interrupt enable is set and other interrupt requirements are met). Software or any reset can clear this bit.

WTRF: WDCON.2 - Watchdog Timer Reset flag. This bit is set whenever a watchdog reset occurs. This bit is useful for determined the cause of a reset. Software must read it, and clear it manually. A Power-fail reset will clear this bit. If EWRST = 0, then this bit will not be affected by the Watchdog Timer.

EWRST: WDCON.1 - Enable Watchdog Timer Reset. This bit when set to 1 will enable the Watchdog Timer reset function. Setting this bit to 0 will disable the Watchdog Timer reset function, but will leave the timer running.

WDCLR: WDCON.0 - Reset Watchdog Timer. This bit is used to clear the Watchdog Timer and to restart it. This bit is self-clearing, so after the software writes 1 to it the hardware will automatically clear it. If the Watchdog Timer reset is enabled, then the WDCLR has to be set by the user within 512 clocks of the time-out. If this is not done then a Watchdog Timer reset will occur.

The WDCON SFR is set to a 0x000000B on a power-on-reset. WTRF (WDCON.2) is set to a 1 on a Watchdog timer reset, but to a 0 on power on/down resets. WTRF (WDCON.2) is not altered by an external reset. EWRST (WDCON.1) is set to 0 on all resets.

Reset Type	By external reset	By Watchdog reset	By Power on reset
Value after the reset	0x00 0x00b	0x00 0100b	0x00 000b

14.2 CLOCK CONTROL of Watchdog

WD1, WD0: WDCON.5, WDCON.4 - Watchdog Timer Mode select bits. These two bits select the time-out interval for the watchdog timer. The reset time is 512 clocks longer than the interrupt time-out value.



The default Watchdog time-out is 2^{12} clocks, which is the shortest time-out period. The WDRUN, WD0, WD1, EWRST, WDIF and WDCLR bits are protected by the Timed Access procedure. This prevents software from accidentally enabling or disabling the watchdog timer. More importantly, it makes it highly improbable that errant code can enable or disable the Watchdog Timer.

The security bit WDTC is located at bit 7 of CONFIG0 register. This bit is for user to configure the clock source of watchdog timer either from the internal RC or from the uC clock.

新唐科技 NUVOTON
INTELLECTUAL PROPERTY

新唐科技 NUVOTON
INTELLECTUAL PROPERTY

15 TIMER2/INPUT CAPTURE MODULES

Timer/Counter 2 is a 16 bit up counter which is configured by the T2MOD register and controlled by the T2CON register. Timer/Counter 2 is also equipped with 3 input captures and reloads capability. As with the Timer 0 and Timer 1 counters, there exists considerable flexibility in selecting and controlling the clock, and in defining the operating mode. The clock source for Timer/Counter 2 crystal oscillator is divided by 1,4,16 or 32 (selectable with CCDIV.1~0 in DIV SFR). The clock is then enabled when TR2 is a 1, and disabled when TR2 is a 0.

15.1 Capture Mode

The capture modules are function to detect and measure pulse width and period of a square wave. It supports 3 capture inputs and digital noise rejection filter. The modules are configured by CAPCON0 and CAPCON1 SFR registers. Input Capture 0, 1 & 2 have their own edge detector but share with one timer i.e. Timer 2. If the Schmitt trigger enable bits at SFR PORTS are set, the Input Capture pins are in the structure with Schmitt trigger. For this operation it basically consists of;

- ◆ 3 capture module function blocks
- ◆ Timer 2 block

Each capture module block consists of 2 bytes capture registers, noise filter and programmable edge triggers. Noise Filter is used to filter the unwanted glitch or pulse on the trigger input pin. The noise filter can be enabled through CAPCON1.ENF_x bit. If enabled, the capture logic required to sample 4 consecutive same capture input value in order to recognize an edge as a capture event. A possible implementation of digital noise filter is as follow;

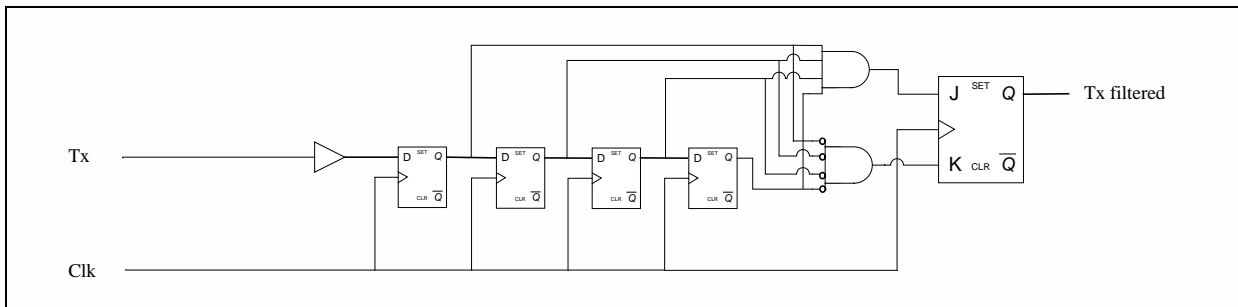

Figure 15-1 Noise filter

The interval between pulses requirement for input capture is 1 machine cycle width, which is the same as the pulse width required to guarantee a trigger for all trigger edge mode. For less than 3 system clocks, anything less than 3 clocks will not have any trigger and pulse width of 3 or more but less than 4 clocks will trigger but will not guarantee 100% because input sampling is at stage C3 of the machine cycle.

The trigger option is programmable through CAPCON0.CCT_x.1~0 bits. It supports positive edge, negative edge and both edge triggers. Each capture module consists of an enable, ICEN0-2.

[Note: x=0/1/2, for capture 0/1/2 block].

Timer/Counter 2 serves as a 16 bit up counter. It supports reload and compared modes. More details are described in next sections.



Capture blocks can be triggered by the following pins/bit;

- ◆ IC0 (P2.4) or ADC compare result bit, ADCPO.
- ◆ IC1 (P2.5)
- ◆ IC2 (P2.6)

If ICEN_x is enabled, each time the external pin trigger, the content of the free running 16 bits counter, TL2 & TH2 (from Timer 2 block) will be captured/transferred into the capture registers, CCL_x and CCH_x, depending which external pin trigger. This action also causes the CPTF_x flag bit in CAPCON1 to be set, which will also generate an interrupt (if enabled by ECPTF bit in SFR EIE1.7). The CPTF0-2 flags are logical "OR" to the interrupt module. Flag is set by hardware and clear by software. Software will have to resolve on the priority of the interrupt flags.

Setting the T2CR bit (T2MOD.3), will allow hardware to reset timer 2 automatically after the value of TL2 and TH2 have been captured. Priority is given to T2CR to reset counter after capture the timer value into the capture register.

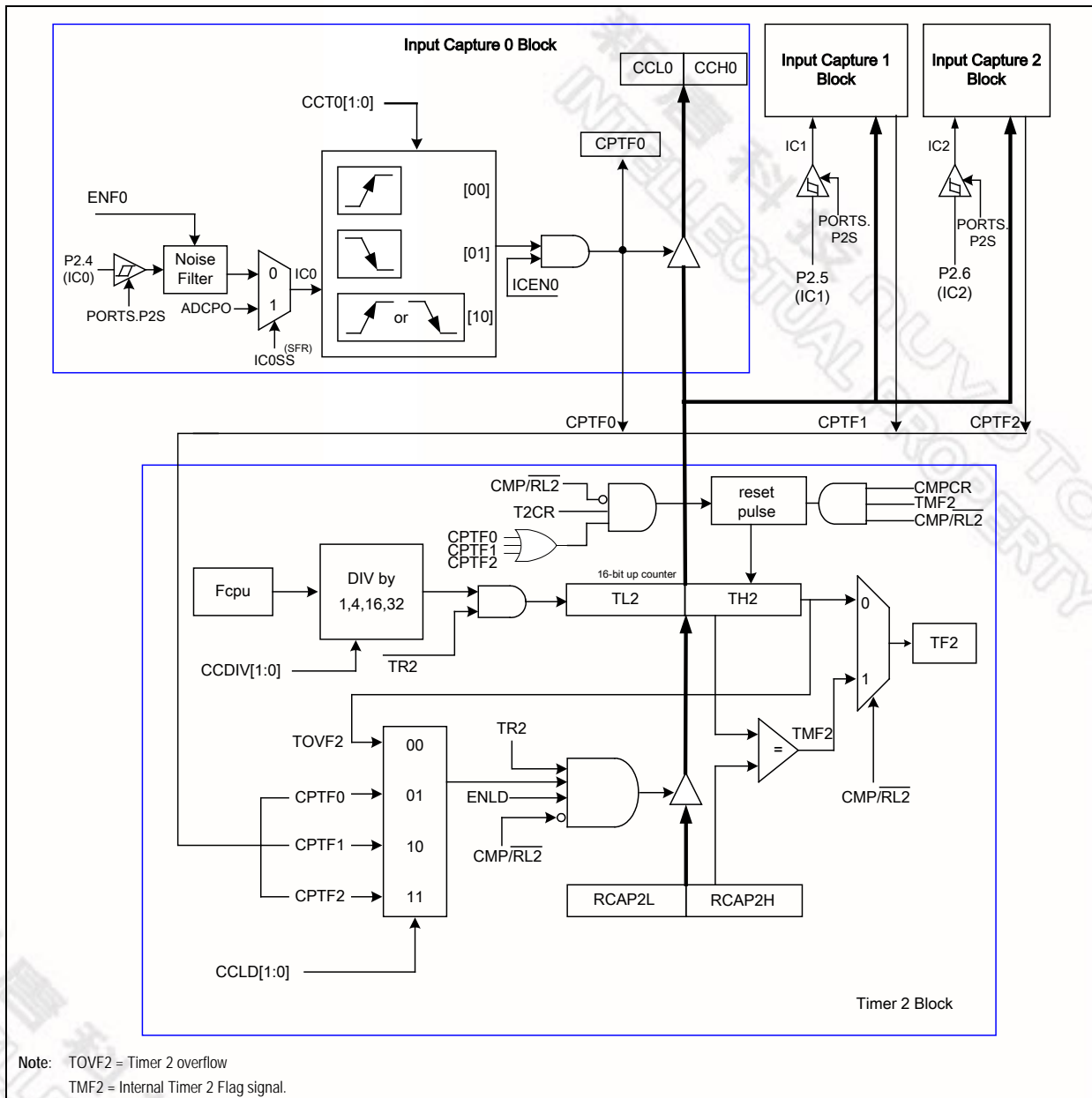

Figure 15-2 Timer2/capture modules

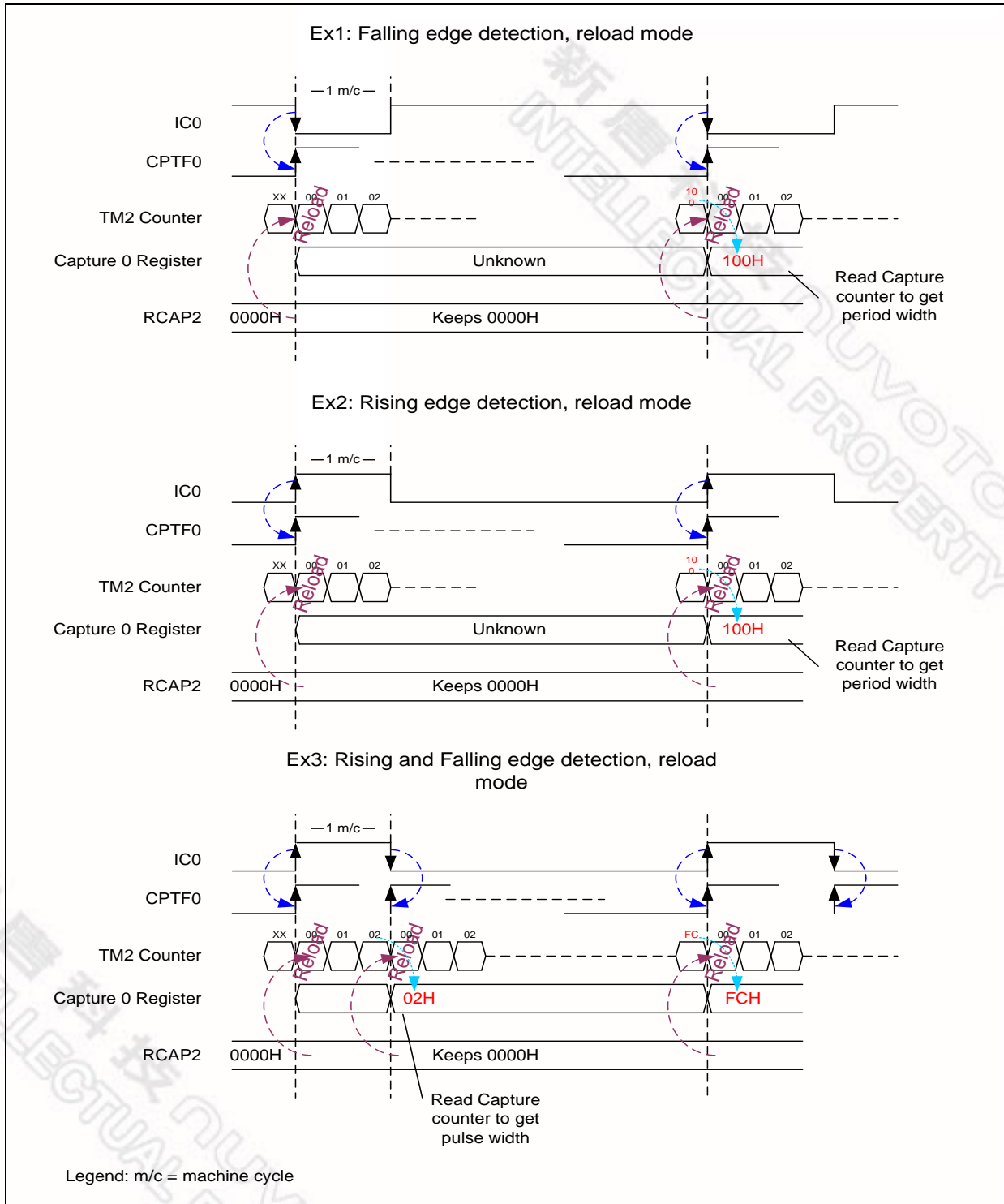

Figure 15-3 Timing diagram for Input Capture, IC0

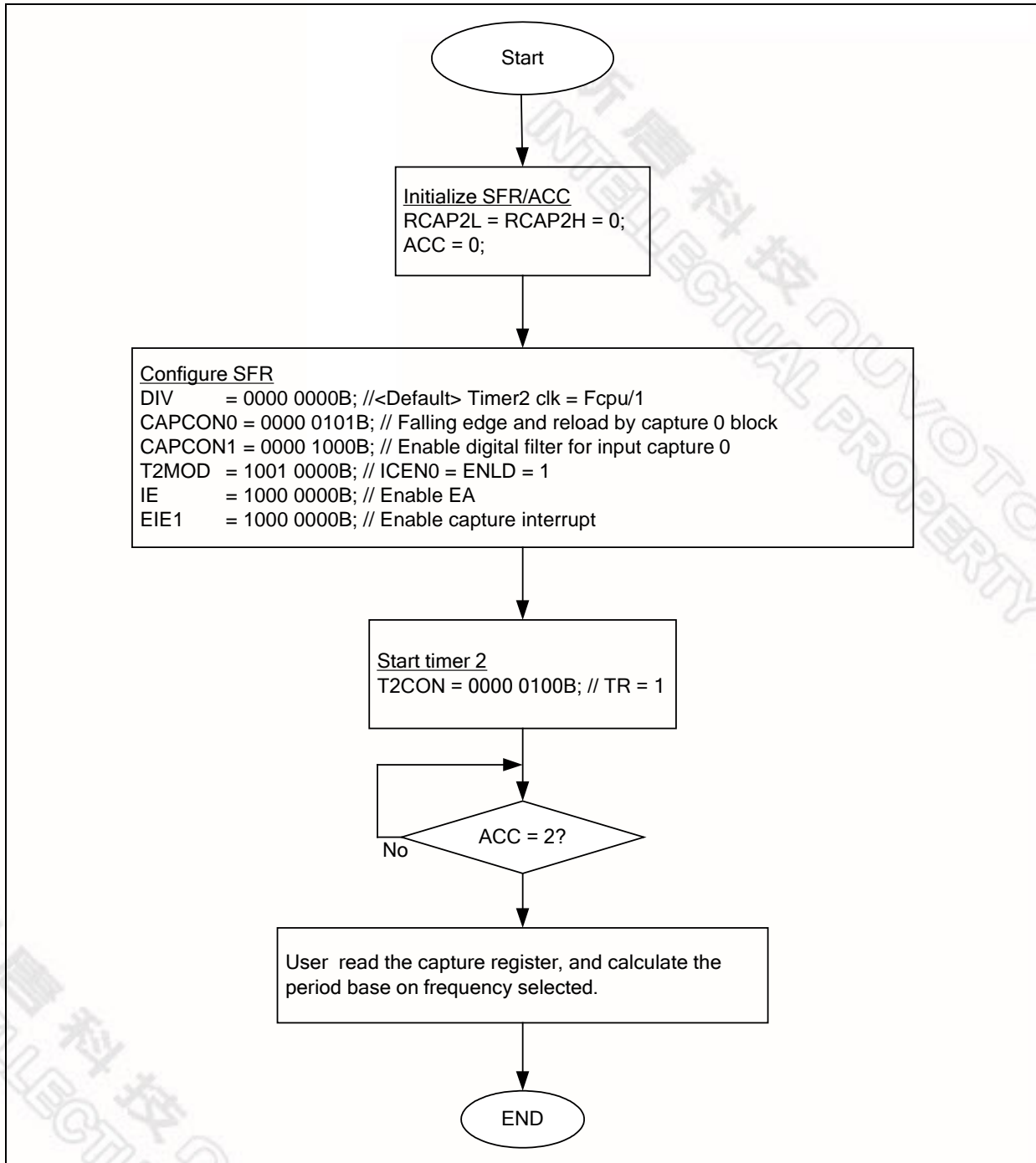

Figure 15-4 Program flow for measurement with IC0 between pulses with falling edge detection (ACC is incremented in interrupt service routine).

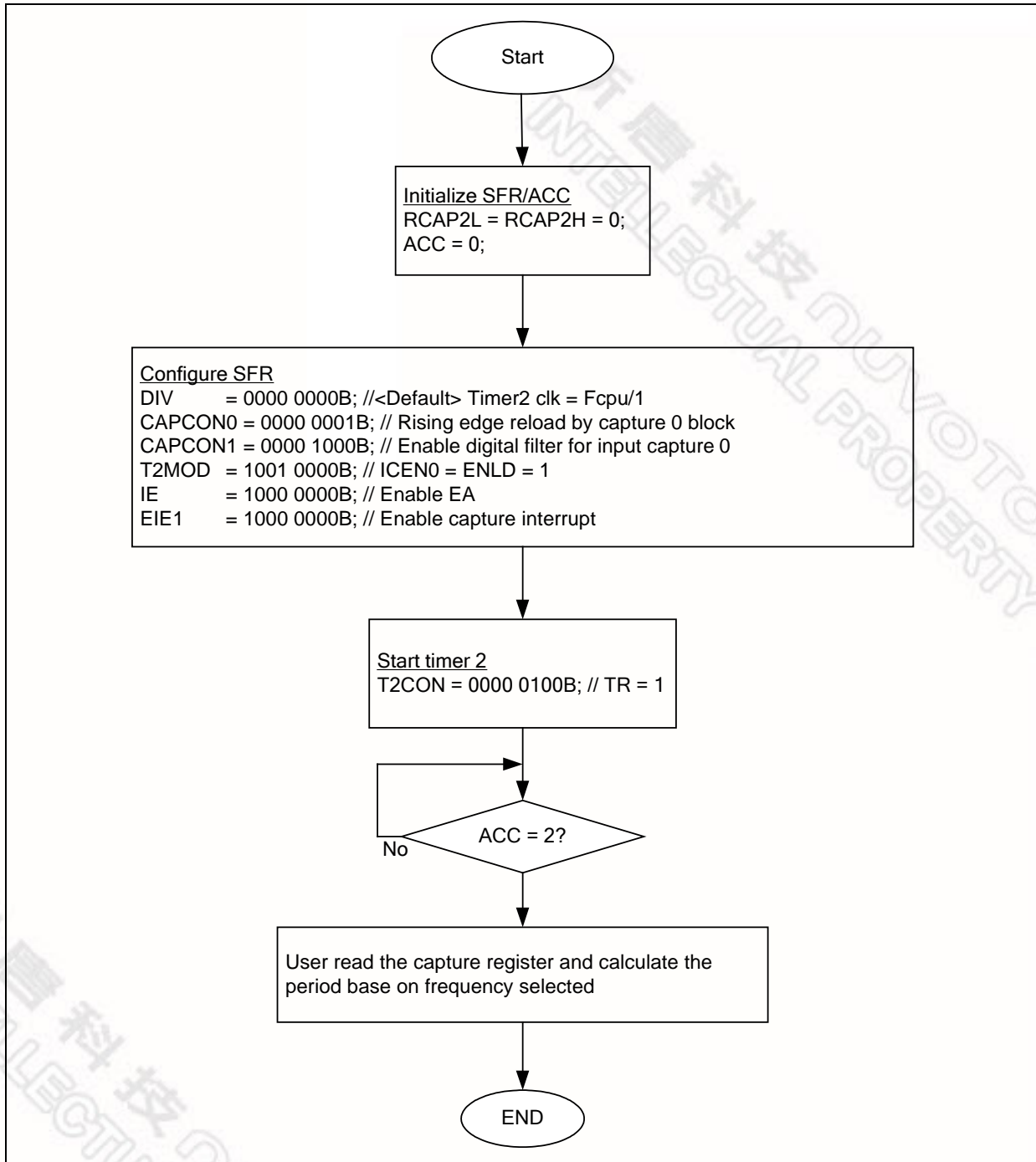

Figure 15-5 Program flow for measurement with IC0 between pulses with rising edge detection (ACC is incremented in interrupt service routine).

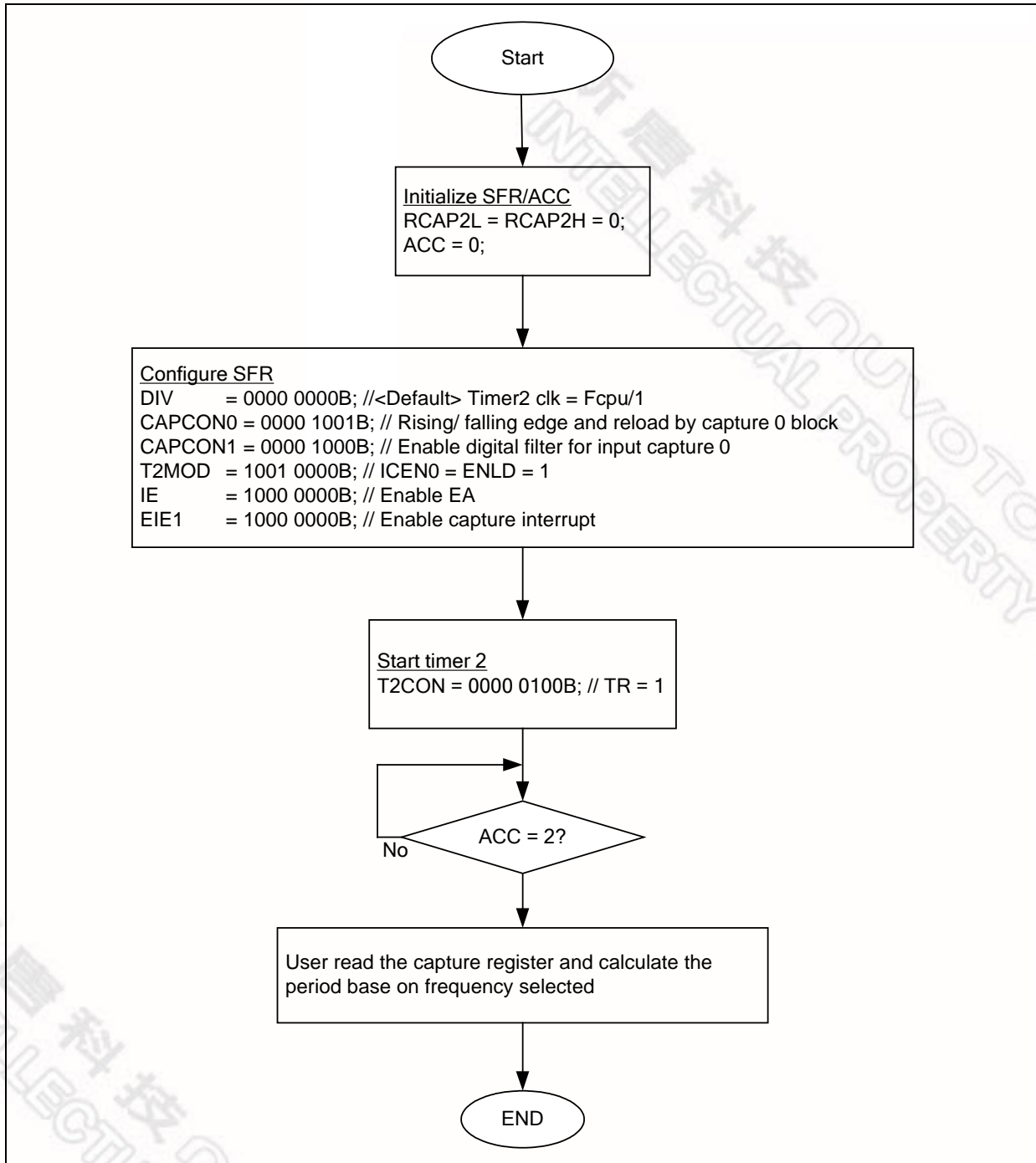

Figure 15-6 Program flow for measurement with IC0 pulse width with rising and falling edge detection (ACC is incremented in interrupt service routine).

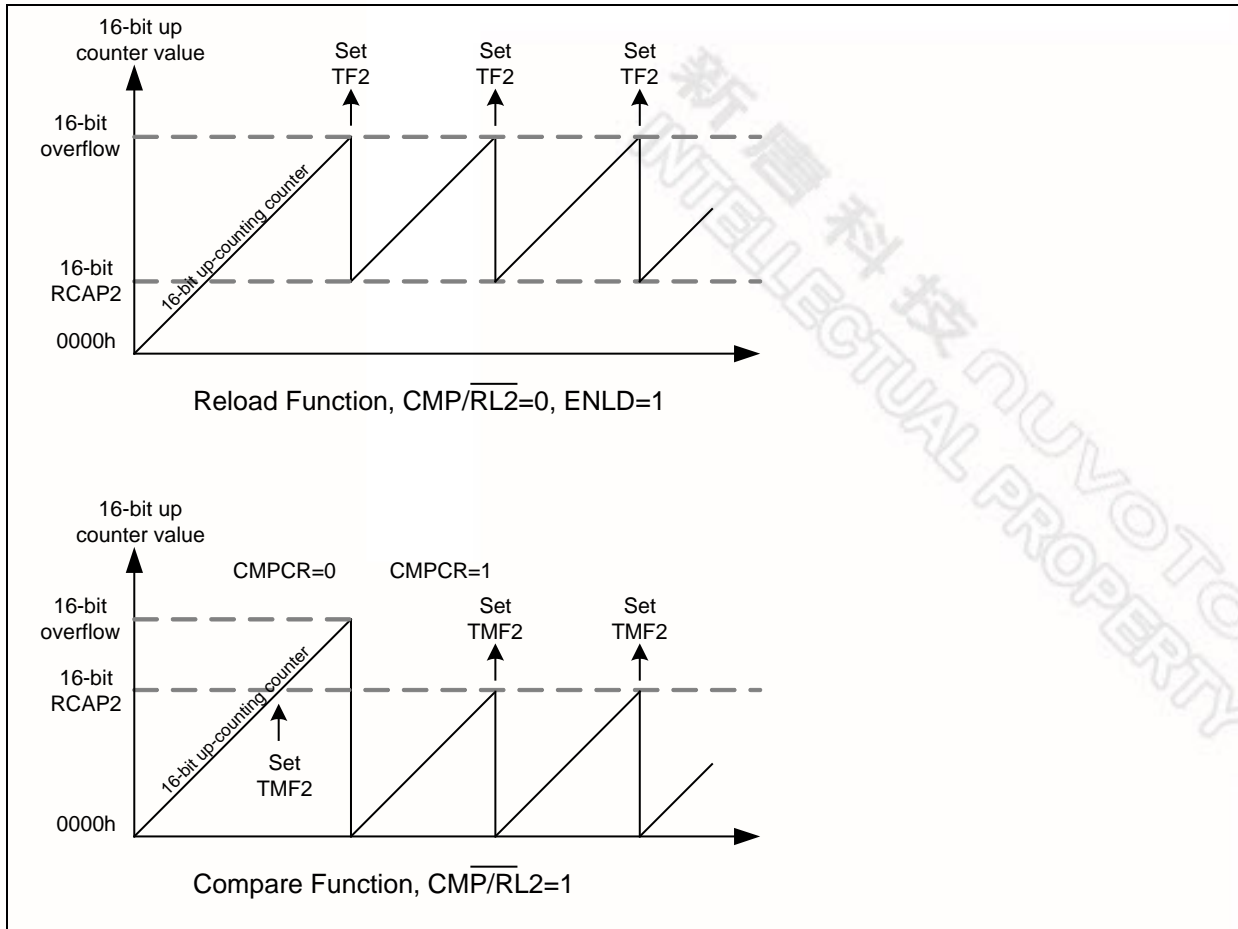

Figure 15-7 Timer 2 - Compare/Reload Function

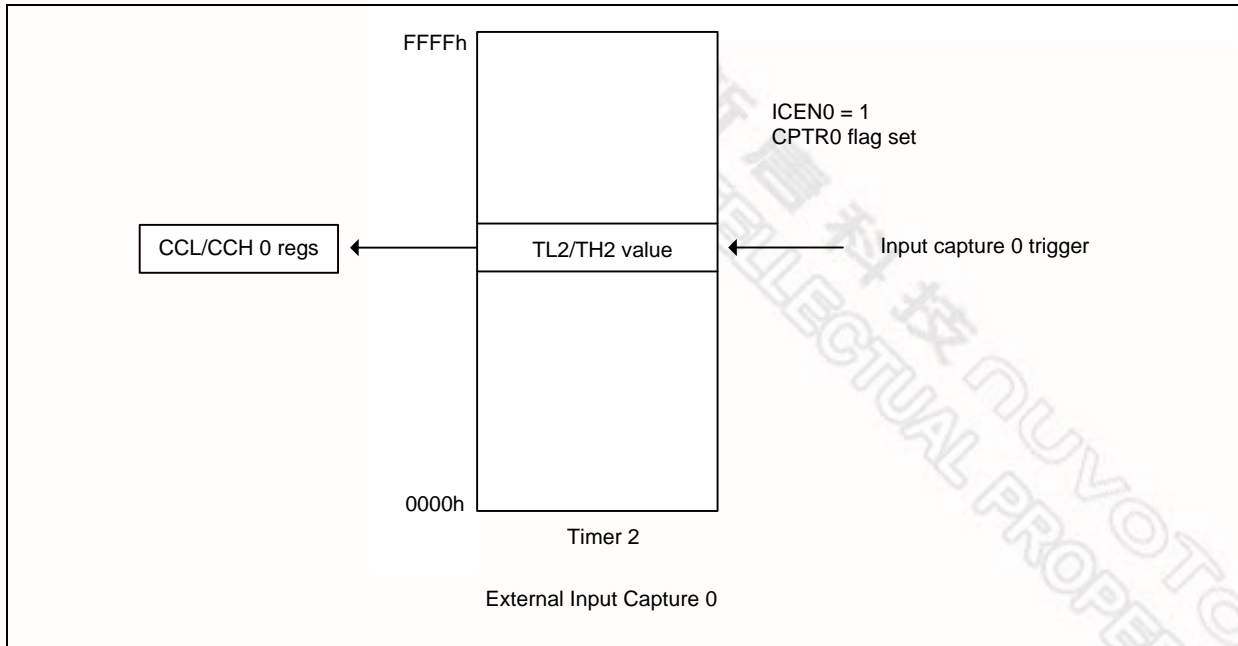

Figure 15-8 Capture module - Input Capture 0 triggers

15.2 Compare Mode

Timer 2 can be configured for compare mode. The compare mode is enabled by setting the CMP/RL2 bit to 1 in the T2CON register. RCAP2 will serve as a compare register. As Timer 2 counting up, upon matching with RCAP2 value, TF2 will be set (which will generate an interrupt request if enable Timer 2 interrupt ET2 is enabled) and the timer reload from 0 and starts counting again.

Setting the CMPCR bit (T2MOD.2), will allow hardware to reset timer 2 automatically after a match has occurred.

15.3 Reload Mode

Timer 2 can be also be configured for reload mode. The reload mode is enabled by clearing the CMP/RL2 bit to 0 in the T2CON register. In this mode, RCAP serves as a reload register. When timer 2 overflows, a reload is generated that causes the contents of the RCAP2L and RCAP2H registers to be reloaded into the TL2 and TH2 registers, if ENLD is set. TF2 flag is set, and interrupt request is generated if enable Timer 2 interrupt ET2 is enabled. However, if ENLD = 0, timer 2 will be reload with 0, and count up again.

Alternatively, other reload source is also possible by the input capture pins by configuring the CCLD.1~0 bits. If the ICENx bit is set, then a trigger of external IC0, IC1 or IC2 pin (respectively) will also cause a reload. This action also sets the CPTF0, CPTF1 or CPTF2 flag bit in SFR CAPCON1, respectively.



16 TIMER3

This device consists of an additional timer; Timer 3. Timer 3 is a 12-bit up counter which supports operation in any one of four possible modes: Timer/counter mode, capture mode, auto-reload mode and compare mode.

SFR T3CON.1~0	T3 mode	T3RST = 0	T3RST = 1
00b	Timer/Counter mode	Timer 3 counts from 000h to FFFh.	
01b	Capture mode	RCAP3L, RCAP3HT3H.7-4 capture content of timer 3. Timer 3 counts from 000h to FFFh.	RCAP3L, RCAP3HT3H.7-4 capture content of timer 3. Timer 3 reset after capture occurs.
10b	Auto-reload mode	RCAP3L, RCAP3HT3H.7-4 serve as reload registers. Timer 3 counts from reload registers content to FFFh.	
11b	Compare mode	RCAP3L, RCAP3HT3H.7-4 serve as compare registers. Timer 3 counts from 000h to FFFh.	RCAP3L, RCAP3HT3H.7-4 serve as compare registers. Timer 3 counts from 000h to compare value.

The following figure shows the timer 3 block diagram.

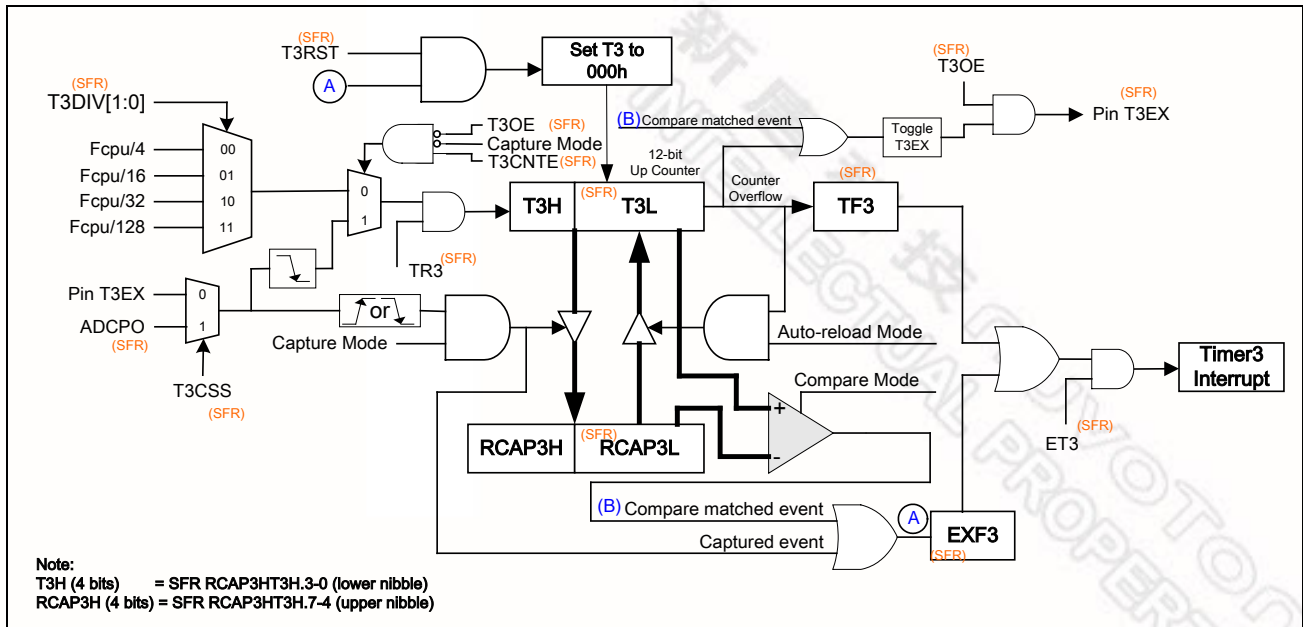

Figure 16-1: Timer 3 block diagram

Note: Timer 3 counter is writable only when TR3 = 0.

The timer clock can be programmed to be of 1/4, 1/16, 1/32 and 1/128 of the Fcpu clock.

16.1 Timer/Counter Mode

Timer 3 has one 8 bits register and 4 bits register forming the 12 bits counting registers. These bits are located at SFR T3L (LSB bits) and RCAP3HT3H.3-0 (MSB bits). The timer can be configured to operate either as timer or as counter counting external input.

The "Timer" or "Counter" function is selected by the T3CNTE bit in the T3CON Special Function Register.

When configured as a "Timer", the timer counts clock cycles. In the "Counter" mode, the register is incremented on the falling edge of the external input pin, T3. The T3 input is sampled in every machine cycle at C4. If the sampled value is high in one machine cycle and low in the next, then a valid high to low transition on the pin is recognized and the count register is incremented.

When enable T3OE, T3 pin is toggled whenever timer 3 overflow (or compare matched occurs).

16.2 Capture Mode

In this mode, each time external pin T3 triggers (either rising or falling edge), the content of timer 3 will be captured/transferred into capture registers, RCAP3L.7-0 and RCAP3HT3H.7-4. This event will cause EXF3 flag bit in SFR T3CON.6 to be set, which will also generate an interrupt if enabled by ET3 bit (EIE2.0). The flag is set by hardware and clear by software. Setting T3RST bit (T3CON.3), will allow hardware to reset timer 3 automatically after the values of timer 3 has been captured. Otherwise, the timer 3 continues counting.

ADC compare result, ADCPO, is another alternative source for capture mode. It is selected by T3CSS bit.

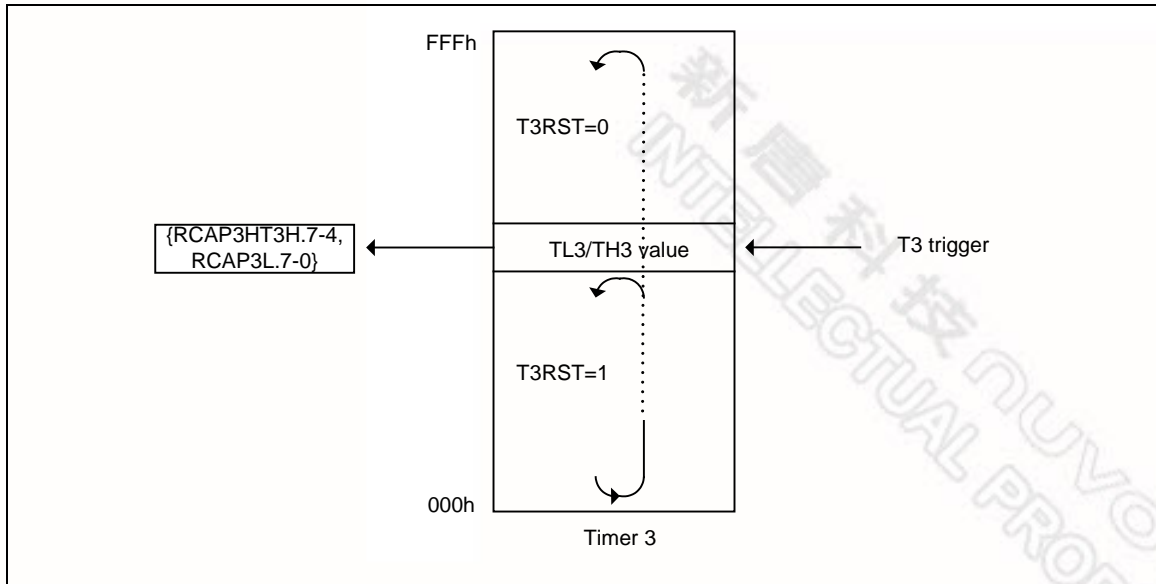

Figure 16-2: Timer 3 – capture function

16.3 Compare Mode

In this mode, RCAP3L and RCAP3HT3H.7-4 serve as compare registers. As timer 3 counting up, upon matching the compare registers, EXF3 flag will also be set. Similarly, an interrupt will be generated if enabled by ET3 bit (EIE2.0). If T3RST = 0, the timer 3 will continue count up, until overflow follow by count up again from zero. Setting T3RST bit, will allow hardware to reset timer 3 automatically after there is compare matched.

When enable T3OE, T3 pin is toggled whenever compare matched occurs (or timer 3 overflows).

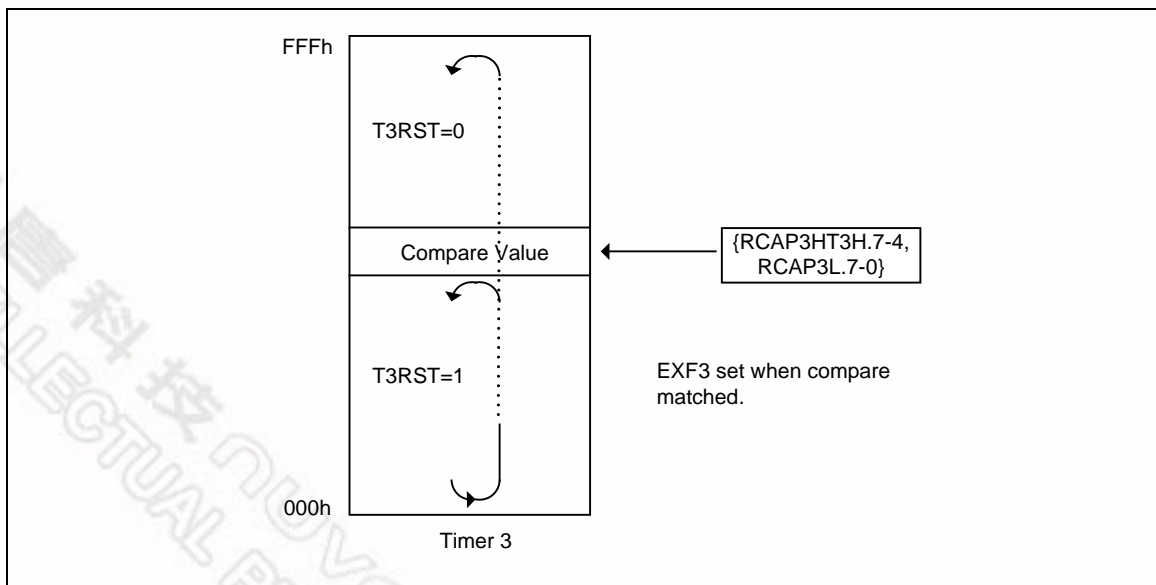

Figure 16-3: Timer 3 – compare function

16.4 Auto-reload Mode

In this mode, RCAP3L and RCAP3HT3H.7-4 serve as reload registers. When timer 3 overflows, a reload is generated that causes the content of RCAP3L and RCAP3HT3H.7-4 reloaded to T3L and RCAP3HT3H.3-0. TF3 flag is set, and interrupt request is generated if ET3 bit is enabled.



17 SERIAL PORT (UART)

Serial port in the N79E875 series is a full duplex port. It provides the user with additional features such as the Frame Error Detection and the Automatic Address Recognition. The serial ports are capable of synchronous as well as asynchronous communication. In Synchronous mode, N79E875 series generate the clock and operates in a half duplex mode. In the asynchronous mode, full duplex operation is available. This means that it can simultaneously transmit and receive data. The transmit register and the receive buffer are both addressed as SBUF Special Function Register. However any write to SBUF will be to the transmit register, while a read from SBUF will be from the receiver buffer register. The serial port can operate in four different modes as described below.

17.1 MODE 0

This mode provides synchronous communication with external devices. In this mode serial data is transmitted and received on the RXD line. TXD is used to transmit the shift clock. The TxD clock is provided whether the device is transmitting or receiving. This mode is therefore a half duplex mode of serial communication. In this mode, 8 bits are transmitted or received per frame. The LSB is Transmitted/Received first. The baud rate is fixed at 1/12 or 1/4 of the oscillator frequency. This Baud Rate is determined by the SM2 bit (SCON.5). When this bit is set to 0, then the serial port runs at 1/12 of the clock. When set to 1, the serial port runs at 1/4 of the clock. This additional facility of programmable baud rate in mode 0 is the only difference between the standard 8051 and N79E875 series.

The functional block diagram is shown below. Data enters and leaves the Serial port on the RxD line. The TxD line is used to output the shift clock. The shift clock is used to shift data into and out of the device. Any instruction that causes a write to SBUF will start the transmission. The shift clock will be activated and data will be shifted out on the RxD pin till all 8 bits are transmitted. If SM2 = 1, then the data on RxD will appear 1 clock period before the falling edge of shift clock on TxD. The clock on TxD then remains low for 2 clock periods, and then goes high again. If SM2 = 0, the data on RxD will appear 3 clock periods before the falling edge of shift clock on TxD. The clock on TxD then remains low for 6 clock periods, and then goes high again. This ensures that at the receiving end the data on RxD line can either be clocked on the rising edge of the shift clock on TxD or latched when the TxD clock is low.

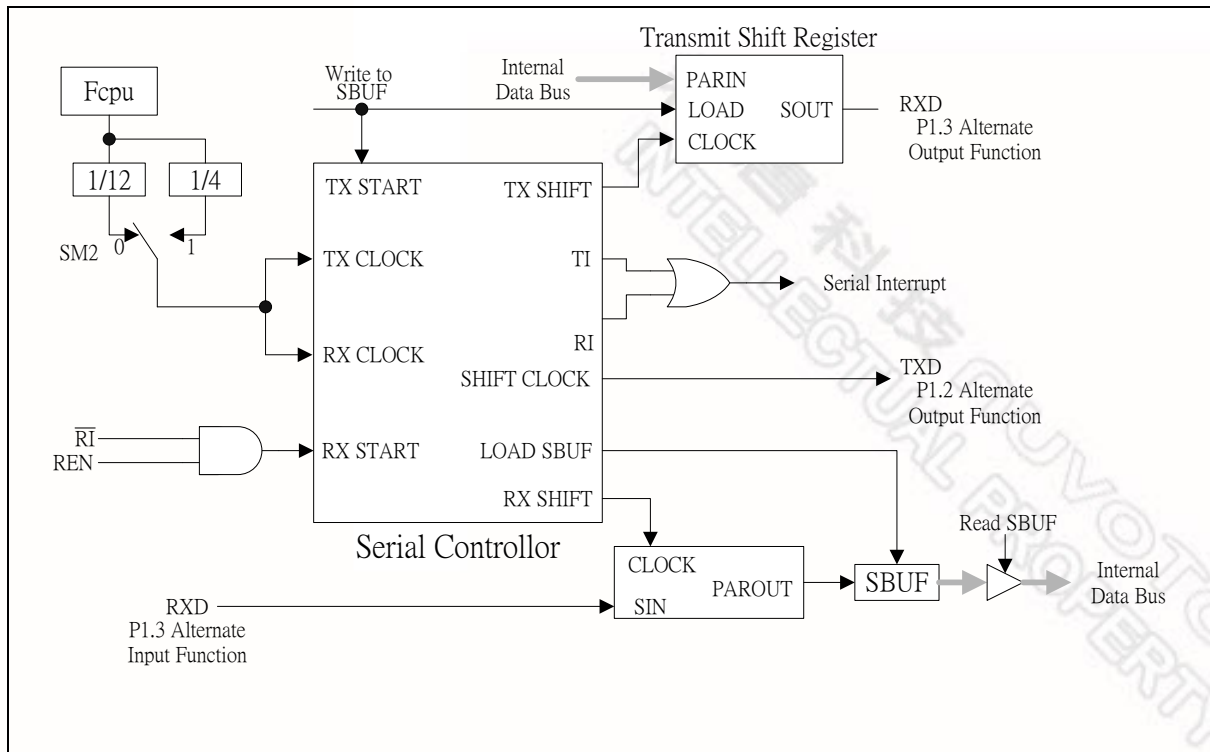

Figure 17-1: Serial Port Mode 0

The TI flag is set high in C1 following the end of transmission of the last bit. The serial port will receive data when REN is 1 and RI is zero. The shift clock (TxD) will be activated and the serial port will latch data on the rising edge of shift clock. The external device should therefore present data on the falling edge on the shift clock. This process continues till all the 8 bits have been received. The RI flag is set in C1 following the last rising edge of the shift clock on TxD. This will stop reception, till the RI is cleared by software.

17.2 MODE 1

In Mode 1, the full duplex asynchronous mode is used. Serial communication frames are made up of 10 bits transmitted on TxD and received on RxD. The 10 bits consist of a start bit (0), 8 data bits (LSB first), and a stop bit (1). On received, the stop bit goes into RB8 in the SFR SCON. The baud rate in this mode is variable. The serial baud can be programmed to be 1/16 or 1/32 of the Timer 1 overflow. Since the Timer 1 can be set to different reload values, a wide variation in baud rates is possible.

Transmission begins with a write to SBUF. The serial data is brought out on to TxD pin at C1 following the first roll-over of divide by 16 counter. The next bit is placed on TxD pin at C1 following the next rollover of the divide by 16 counter. Thus the transmission is synchronized to the divide by 16 counters and not directly to the write to SBUF signal. After all 8 bits of data are transmitted, the stop bit is transmitted. The TI flag is set in the C1 state after the stop bit has been put out on TxD pin. This will be at the 10th rollover of the divide by 16 counters after a write to SBUF.

Reception is enabled only if REN is high. The serial port actually starts the receiving of serial data, with the detection of a falling edge on the RxD pin. The 1-to-0 detector continuously monitors the RxD line, sampling it at the rate of 16 times the selected baud rate. When a falling edge is detected, the divide by 16 counters is immediately reset. This helps to align the bit boundaries with the rollovers of the divide by 16 counters.

The 16 states of the counter effectively divide the bit time into 16 slices. The bit detection is done on a

best of three bases. The bit detector samples the RxD pin, at the 8th, 9th and 10th counter states. By using a majority 2 of 3 voting system, the bit value is selected. This is done to improve the noise rejection feature of the serial port. If the first bit detected after the falling edge of RxD pin is not 0, then this indicates an invalid start bit, and the reception is immediately aborted. The serial port again looks for a falling edge in the RxD line. If a valid start bit is detected, then the rest of the bits are also detected and shifted into the SBUF.

After shifting in 8 data bits, there is one more shift to do, after which the SBUF and RB8 are loaded and RI is set. However certain conditions must be met before the loading and setting of RI can be done.

1. RI must be 0 and
2. Either SM2 = 0, or the received stop bit = 1.

If these conditions are met, then the stop bit goes to RB8, the 8 data bits go into SBUF and RI is set. Otherwise the received frame may be lost. After the middle of the stop bit, the receiver goes back to looking for a 1-to-0 transition on the RxD pin.

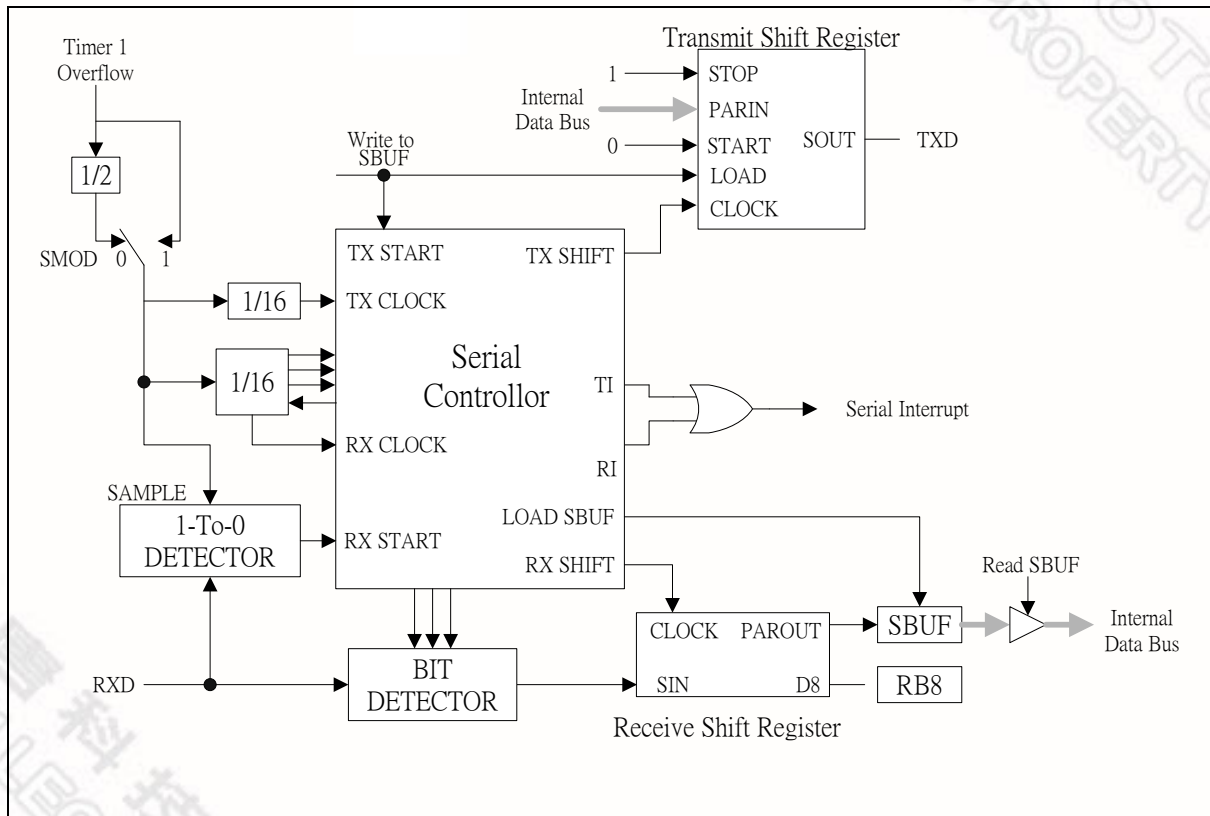

Figure 17-2: Serial Port Mode 1

17.3 MODE 2

This mode uses a total of 11 bits in asynchronous full-duplex communication. The functional description is shown in the figure below. The frame consists of one start bit (0), 8 data bits (LSB first), a programmable 9th bit (TB8) and a stop bit (0). The 9th bit received is put into RB8. The baud rate is programmable to 1/32 or 1/64 of the oscillator frequency, which is determined by the SMOD bit in PCON SFR. Transmission begins with a write to SBUF. The serial data is brought out on to TxD pin at C1 following the first roll-over of the divide by 16 counter. The next bit is placed on TxD pin at C1 following the next rollover of the divide by 16 counter. Thus the transmission is synchronized to the divide by 16 counters, and not directly to the write to SBUF signal. After all 9 bits of data are transmitted, the stop bit is transmitted. The TI flag is set in the C1 state after the stop bit has been put out on TxD pin. This will be at the 11th rollover of the divide by 16 counters after a write to SBUF. Reception is enabled only if REN is high. The serial port actually starts the receiving of serial data, with the detection of a falling edge on the RxD pin. The 1-to-0 detector continuously monitors the RxD line, sampling it at the rate of 16 times the selected baud rate. When a falling edge is detected, the divide by 16 counters is immediately reset. This helps to align the bit boundaries with the rollovers of the divide by 16 counters. The 16 states of the counter effectively divide the bit time into 16 slices. The bit detection is done on a best of three bases. The bit detector samples the RxD pin, at the 8th, 9th and 10th counter states. By using a majority 2 of 3 voting system, the bit value is selected. This is done to improve the noise rejection feature of the serial port.

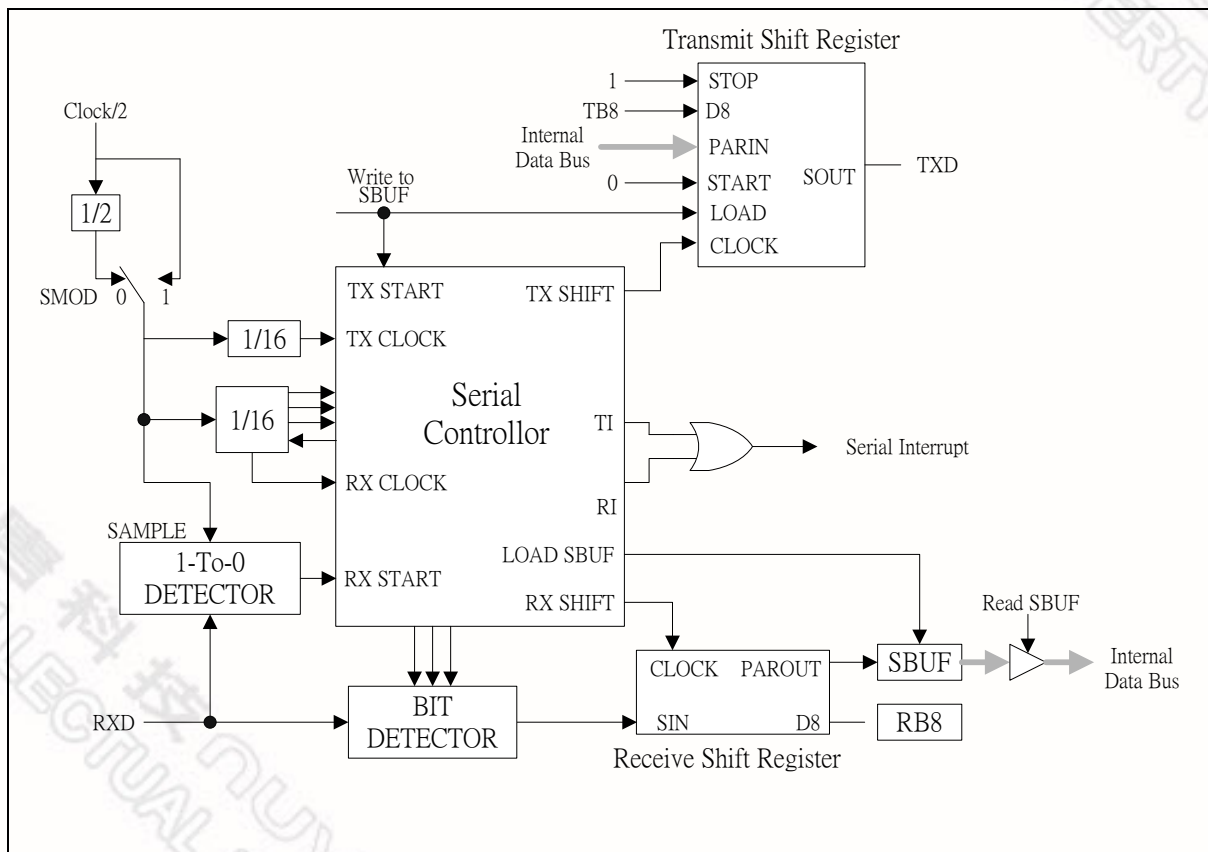

Figure 17-3: Serial Port Mode 2

If the first bit detected after the falling edge of RxD pin, is not 0, then this indicates an invalid start bit, and the reception is immediately aborted. The serial port again looks for a falling edge in the RxD line. If a valid start bit is detected, then the rest of the bits are also detected and shifted into the SBUF.

After shifting in 9 data bits, there is one more shift to do, after which the SBUF and RB8 are loaded and RI is set. However certain conditions must be met before the loading and setting of RI can be done.

1. RI must be 0 and
2. Either SM2 = 0, or the received stop bit = 1.

If these conditions are met, then the stop bit goes to RB8, the 8 data bits go into SBUF and RI is set. Otherwise the received frame may be lost. After the middle of the stop bit, the receiver goes back to looking for a 1-to-0 transition on the RxD pin.

17.4 MODE 3

This mode is similar to Mode 2 in all respects, except that the baud rate is programmable. The user must first initialize the Serial related SFR SCON before any communication can take place. This involves selection of the Mode and baud rate. The Timer 1 should also be initialized if modes 1 and 3 are used. In all four modes, transmission is started by any instruction that uses SBUF as a destination register. Reception is initiated in Mode 0 by the condition RI = 0 and REN = 1. This will generate a clock on the TxD pin and shift in 8 bits on the RxD pin. Reception is initiated in the other modes by the incoming start bit if REN = 1. The external device will start the communication by transmitting the start bit.

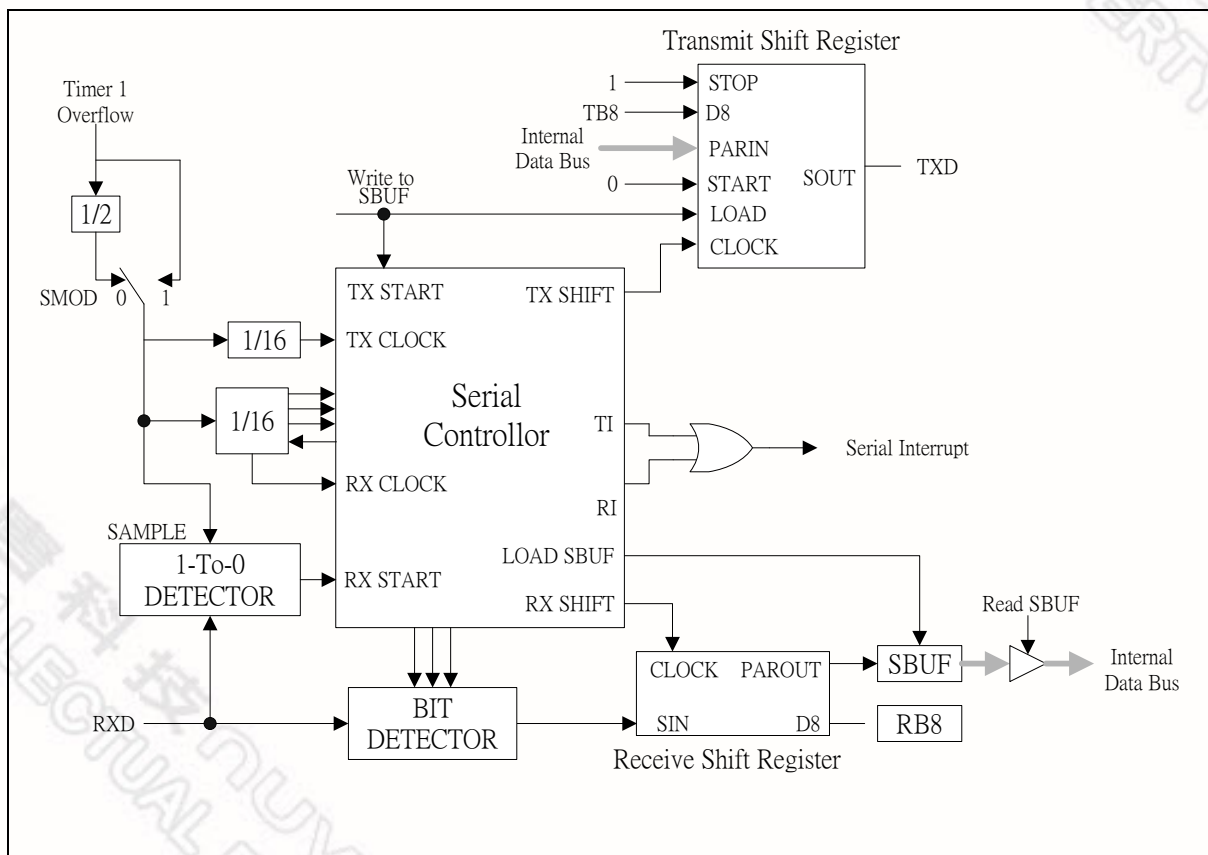

Figure 17-4: Serial Port Mode 3

SM0	SM1	MODE	TYPE	BAUD CLOCK	FRAME SIZE	START BIT	STOP BIT	9TH BIT FUNCTION
0	0	0	Synch.	4 or 12 TCLKS	8 bits	No	No	None
0	1	1	Asynch.	Timer 1	10 bits	1	1	None
1	0	2	Asynch.	32 or 64 TCLKS	11 bits	1	1	0, 1
1	1	3	Asynch.	Timer 1	11 bits	1	1	0, 1

Figure 17-5: Serial Ports Modes

17.5 Framing Error Detection

A Frame Error occurs when a valid stop bit is not detected. This could indicate incorrect serial data communication. Typically the frame error is due to noise and contention on the serial communication line. N79E875 series have the capability to detect such framing errors and set a flag which can be checked by software.

The Frame Error FE bit is located in SCON.7. This bit is normally used as SM0 in the standard 8051 family. However, it serves a dual function and is called SM0/FE. There are actually two separate flags, one for SM0 and the other for FE. The flag that is actually accessed as SCON.7 is determined by SMOD0 (PCON.6) bit. When SMOD0 is set to 1, then the FE flag is indicated in SM0/FE. When SMOD0 is set to 0, then the SM0 flag is indicated in SM0/FE.

The FE bit is set to 1 by hardware but must be cleared by software. Note that SMOD0 must be 1 while reading or writing to FE. If FE is set, then any following frames received without any error will not clear the FE flag. The clearing has to be done by software.

17.6 Multiprocessor Communications

Multiprocessor communications makes use of the 9th data bit in modes 2 and 3. The RI flag is set only if the received byte corresponds to the Given or Broadcast address. This hardware feature eliminates the software overhead required in checking every received address, and greatly simplifies the software programmer task.

In the multiprocessor communication mode, the address bytes are distinguished from the data bytes by transmitting the address with the 9th bit set high. When the master processor wants to transmit a block of data to one of the slaves, it first sends out the address of the targeted slave (or slaves). All the slave processors should have their SM2 bit set high when waiting for an address byte. This ensures that they will be interrupted only by the reception of an address byte. The Automatic address recognition feature ensures that only the addressed slave will be interrupted. The address comparison is done in hardware not software.

The addressed slave clears the SM2 bit, thereby clearing the way to receive data bytes. With SM2 = 0, the slave will be interrupted on the reception of every single complete frame of data. The unaddressed slaves will be unaffected, as they will be still waiting for their address. In Mode 1, the 9th bit is the stop bit, which is 1 in case of a valid frame. If SM2 is 1, then RI is set only if a valid frame is received and the received byte matches the Given or Broadcast address.

The Master processor can selectively communicate with groups of slaves by using the Given Address. All the slaves can be addressed together using the Broadcast Address. The addresses for each slave are defined by the SADDR and SADEN SFRs. The slave address is an 8-bit value specified in the SADDR SFR. The SADEN SFR is actually a mask for the byte value in SADDR. If a bit position in SADEN is 0, then the corresponding bit position in SADDR is don't care. Only those bit positions in SADDR whose corresponding bits in SADEN are 1 are used to obtain the Given Address. This gives



the user flexibility to address multiple slaves without changing the slave address in SADDR.

The following example shows how the user can define the Given Address to address different slaves.

Slave 1:

SADDR 1010 0100

SADEN 1111 1010

Given: 1010 0x0x

Slave 2:

SADDR 1010 0111

SADEN 1111 1001

Given : 1010 0xx1

The Given address for slave 1 and 2 differ in the LSB. For slave 1, it is don't care, while for slave 2 it is 1. Thus to communicate only with slave 1, the master must send an address with LSB = 0 (1010 0000). Similarly the bit 1 position is 0 for slave 1 and don't care for slave 2. Hence to communicate only with slave 2 the master has to transmit an address with bit 1 = 1 (1010 0011). If the master wishes to communicate with both slaves simultaneously, then the address must have bit 0 = 1 and bit 1 = 0. The bit 3 position is don't care for both the slaves. This allows two different addresses to select both slaves (1010 0001 and 1010 0101).

The master can communicate with all the slaves simultaneously with the Broadcast Address. This address is formed from the logical OR of the SADDR and SADEN SFRs. The zeros in the result are defined as don't cares. In most cases the Broadcast Address is FFh. In the previous case, the Broadcast Address is (1111111X) for slave 1 and (11111111) for slave 2.

The SADDR and SADEN SFRs are located at address A9h and B9h respectively. On reset, these two SFRs are initialized to 00h. This results in Given Address and Broadcast Address being set as XXXX XXXb (i.e. all bits don't care). This effectively removes the multiprocessor communications feature, since any selectivity is disabled.

18 I2C SERIAL CONTROL

The I2C bus uses two wires (SDA and SCL) to transfer information between devices connected to the bus. The main features of the bus are:

- Bidirectional data transfer between masters and slaves
- Multi-master bus (no central master)
- Arbitration between simultaneously transmitting masters without corruption of serial data on the bus
- Serial clock synchronization allows devices with different bit rates to communicate via one serial bus
- Serial clock synchronization can be used as a handshake mechanism to suspend and resume serial transfer
- Built-in a 14-bit time-out counter will request the I2C interrupt if the I2C bus hangs up and timer-out counter overflows.
- The I2C port pins, SDA and SCL are permanently in Open-drain type. External pull-up are needed for high output

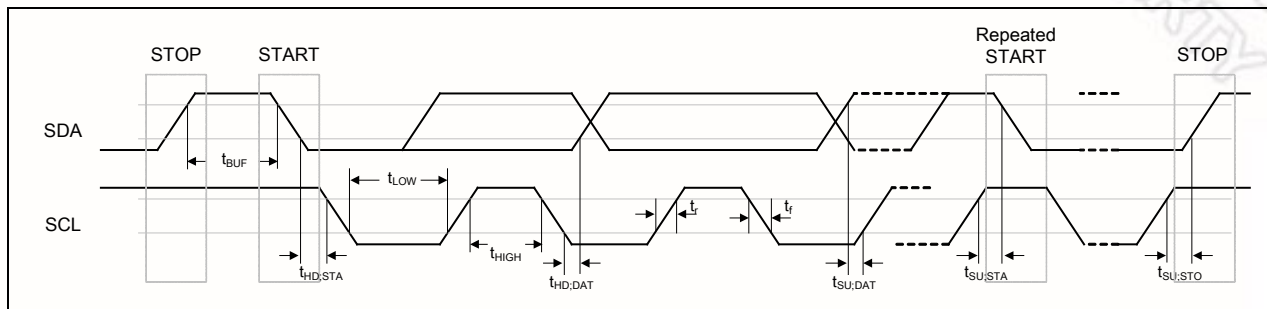

Figure 18-1: I2C Bus Timing

18.1 I2C Port

The device's on-chip I2C logic provides the serial interface that meets the I2C bus standard mode specification. The I2C port handles byte transfers autonomously. To enable this port, the bit ENSI in I2CON should be set to '1'. The I2C H/W interfaces to the I2C bus via two pins: SDA (P1.6, serial data line) and SCL (P1.5, serial clock line). **Pull up resistors are needed on Pin P1.5 and P1.6 for I2C operation as these are open drain pins.** When the I/O pins are used as I2C port, user must set the pins to logic high in advance.

18.2 SFR for I2C Function

The CPU interfaces to the SIO port through the following six special function registers: **I2CON** (control register, C0H), **I2STATUS** (status register, BDH), **I2DAT** (data register, BCH), **I2ADDR** (address registers, C1H), **I2CLK** (clock rate register BEH) and **I2TOC** (Time-out counter register, BFH).

When I2C port is enabled by setting ENSI to high, the internal states will be controlled by I2CON and I2C logic hardware. Once a new status code is generated and stored in I2STATUS, the I2C interrupt flag (SI) will be set automatically. If both EA and EI2C are also in logic high, the I2C interrupt is requested. The 5 most significant bits of I2STATUS stores the internal state code, the lowest 3 bits are always zero and the content keeps stable until SI is cleared by software.

18.2.1 I2C Address Registers, I2ADDR

I2C port is equipped with one slave address register. The contents of the register are irrelevant when I2C is in master mode. In the slave mode, the seven most significant bits must be loaded with the MCU's own slave address. The I2C hardware will react if the contents of I2ADDR are matched with the received slave address.

The I2C ports support the "General Call" function. If the GC bit is set the I2C port1 hardware will respond to General Call address (00H). Clear GC bit to disable general call function.

When GC bit is set, the I2C is in Slave mode, it can be received the general call address by 00H after Master send general call address to I2C bus, then it will follow status of GC mode. If it is in Master mode, the AA bit must be cleared when it will send general call address of 00H to I2C bus.

SYMBOL	DEFINITION	ADDRESS	MSB	BIT ADDRESS, SYMBOL							LSB	RESET
I2ADDR	I2C ADDRESS1	C1H	ADDR.7	ADDR.6	ADDR.5	ADDR.4	ADDR.3	ADDR.2	ADDR.1	GC	xxxx	xxx0B

18.2.2 I2C Data Register, I2DAT

This register contains a byte of serial data to be transmitted or a byte which has just been received. The CPU can read from or write to this 8-bit directly addressable SFR while it is not in the process of shifting a byte. This occurs when SIO is in a defined state and the serial interrupt flag (SI) is set. Data in I2DAT remains stable as long as SI bit is set. While data is being shifted out, data on the bus is simultaneously being shifted in; I2DAT always contains the last data byte present on the bus. Thus, in the event of arbitration lost, the transition from master transmitter to slave receiver is made with the correct data in I2DAT.

I2DAT and the acknowledge bit form a 9-bit shift register, the acknowledge bit is controlled by the SIO hardware and cannot be accessed by the CPU. Serial data is shifted through the acknowledge bit into I2DAT on the rising edges of serial clock pulses on the SCL line. When a byte has been shifted into I2DAT, the serial data is available in I2DAT, and the acknowledge bit (ACK or NACK) is returned by the control logic during the ninth clock pulse. Serial data is shifted out from I2DAT on the falling edges of SCL clock pulses, and is shifted into I2DAT on the rising edges of SCL clock pulses.

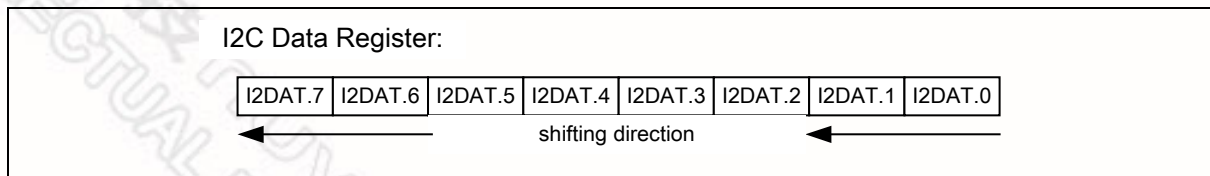

Figure 18-2 I2C Data Shifting Direction

SYMBOL	DEFINITION	ADDRESS	MSB BIT ADDRESS, SYMBOL									LSB	RESET
I2DAT	I2C DATA REGISTER	BCH	I2DAT.7	I2DAT.6	I2DAT.5	I2DAT.4	I2DAT.3	I2DAT.2	I2DAT.1	I2DAT.0		xxxx xxxxB	

18.2.3 I2C Control Register, I2CON

The CPU can read from and write to this 8-bit, directly addressable SFR. Two bits are affected by hardware: the SI bit is set when the I2C hardware requests a serial interrupt, and the STO bit is cleared when a STOP condition is present on the bus. The STO bit is also cleared when ENSI = "0".

- ENSI Set to enable I2C serial function block. When ENS=1 the I2C serial function enables. The port latches of SDA1 and SCL1 must be set to logic high.
- STA I2C START Flag. Setting STA to logic 1 to enter master mode, the I2C hardware sends a START or repeat START condition to bus when the bus is free.
- STO I2C STOP Flag. In master mode, setting STO to transmit a STOP condition to bus then I2C hardware will check the bus condition if a STOP condition is detected this flag will be cleared by hardware automatically. In a slave mode, setting STO resets I2C hardware to the defined "not addressed" slave mode. This means it is NO LONGER in the slave receiver mode to receive data from the master transmit device.
- SI I2C Interrupt Flag. When a new SIO state is present in the I2STATUS register, the SI flag is set by hardware, and if the EA and EI2C bits are both set, the I2C interrupt is requested. SI must be cleared by software.
- AA Assert Acknowledge control bit. When AA=1 prior to address or data received, an acknowledged (low level to SDA) will be returned during the acknowledge clock pulse on the SCL line when 1.) A slave is acknowledging the address sent from master, 2.) The receiver devices are acknowledging the data sent by transmitter. When AA=0 prior to address or data received, a Not acknowledged (high level to SDA) will be returned during the acknowledge clock pulse on the SCL line.

SYMBOL	DEFINITION	ADDRESS	MSB BIT ADDRESS, SYMBOL									LSB	RESET
I2CON	I2C CONTROL REGISTER	C0H	(CF) -	(CE) ENSI	(CD) STA	(CC) STO	(CB) SI	(CA) AA	(C9) -	(C8) -		x000 00xxB	

18.2.4 I2C Status Register, I2STATUS

I2STATUS is an 8-bit read-only register. The three least significant bits are always 0. The five most significant bits contain the status code. There are 26 possible status codes. When I2STATUS contains F8H, no serial interrupt is requested. All other I2STATUS values correspond to defined SIO states. When each of these states is entered, a status interrupt is requested (SI = 1). A valid status code is present in I2STATUS one machine cycle after SI is set by hardware and is still present one machine cycle after SI has been reset by software.

In addition, state 00H stands for a Bus Error. A Bus Error occurs when a START or STOP condition is present at an illegal position in the format frame. Examples of illegal positions are during the serial transfer of an address byte, a data byte or an acknowledge bit. To recover I2C from bus error, STO should be set and SI should be clear to enter not addressed slave mode. Then clear STO to release bus and to wait new communication. I2C bus can not recognize stop condition during this action when bus error occurs.

SYMBOL	DEFINITION	ADDRESS	MSB BIT ADDRESS, SYMBOL								LSB	RESET
I2STATUS	I2C STATUS REGISTER	BDH	B7	B6	B5	B4	B3	B2	B1	B0		1111 1000B

18.2.5 I2C Clock Baud Rate Bits, I2CLK

The data baud rate of I2C is determined by I2CLK register when SIO is in a master mode. It is not important when SIO is in a slave mode. In the slave modes, SIO will automatically synchronize with any clock frequency up to 400 KHz from master I2C device.

The data baud rate of I2C setting is Data Baud Rate of I2C = $F_{cpu} / (4 \times (I2CLK + 1))$. If $F_{cpu} = 16\text{MHz}$, the $I2CLK = 40(28H)$, so data baud rate of I2C = $16\text{MHz} / (4 \times (40 + 1)) = 97.5\text{Kbits/sec}$. The block diagram is as below figure.

SYMBOL	DEFINITION	ADDRESS	MSB	BIT ADDRESS, SYMBOL								LSB	RESET
I2CLK	I2C CLOCK RATE	BEH	I2CLK.7	I2CLK.6	I2CLK.5	I2CLK.4	I2CLK.3	I2CLK.2	I2CLK.1	I2CLK.0	0000	0000B	

18.2.6 I2C Time-out Counter Register, I2TOC

There is a 14-bit time-out counter which can be used to deal with the I2C bus hang-up. If the time-out counter is enabled, the counter starts up counting until it overflows (TIF=1) and requests I2C interrupt from CPU or stops counting by clearing ENTI to 0. When time-out counter is enabled, setting flag SI to high will reset counter and re-start up counting after SI is cleared. If I2C bus hangs up, it causes the I2STATUS and flag SI are not updated for a period, the 14-bit time-out counter may overflow and acknowledge CPU the I2C interrupt. Refer to Figure 18-3 for the 14-bit time-out counter.

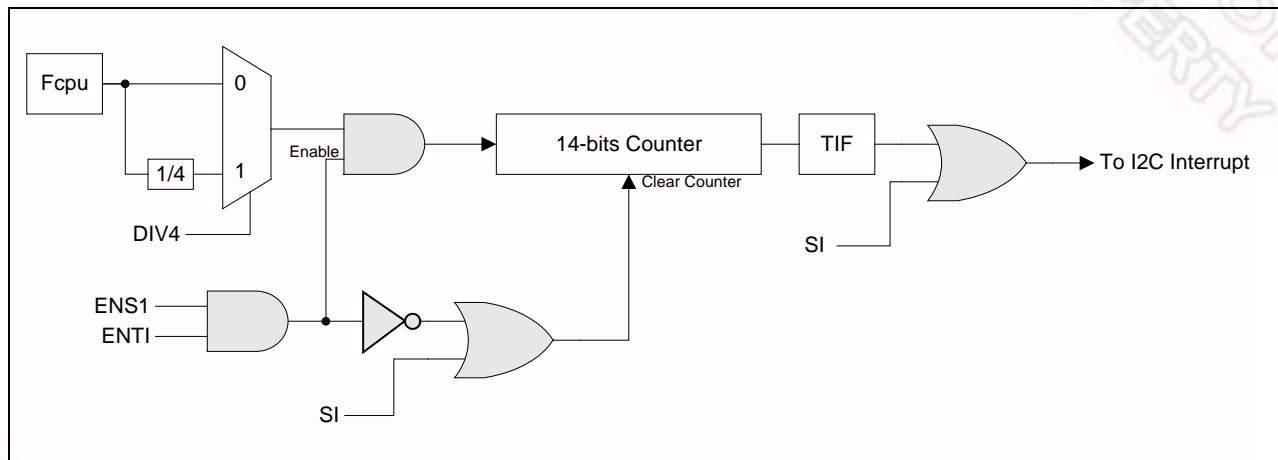

Figure 18-3: I2C Time-out Count Block Diagram

SYMBOL	DEFINITION	ADDRESS	MSB	BIT ADDRESS, SYMBOL								LSB	RESET
I2TOC	I2C TIME-OUT COUNTER REGISTER	BFH	-	-	-	-	-	-	ENTI	DIV4	TIF	0000 0000B	

18.3 Modes of Operation

The on-chip I2C ports support five operation modes, Master transmitter, Master receiver, Slave transmitter, Slave receiver, and GC call.

In a given application, I2C port may operate as a master or as a slave. In the slave mode, the I2C port hardware looks for its own slave address and the general call address. If one of these addresses is detected, and if the slave is willing to receive or transmit data from/to master (by setting the AA bit), acknowledge pulse will be transmitted out on the 9th clock, hence an interrupt is requested on both master and slave devices if interrupt is enabled. When the microcontroller wishes to become the bus master, the hardware waits until the bus is free before the master mode is entered so that a possible slave action is not interrupted. If bus arbitration is lost in the master mode, I2C port switches to the

slave mode immediately and can detect its own slave address in the same serial transfer.

18.3.1 Master Transmitter Mode

Serial data output through SDA while SCL outputs the serial clock. The first byte transmitted contains the slave address of the receiving device (7 bits) and the data direction bit. In this case the data direction bit (R/W) will be logic 0, and it is represented by “W” in the flow diagrams. Thus the first byte transmitted is SLA+W. Serial data is transmitted 8 bits at a time. After each byte is transmitted, an acknowledge bit is received. START and STOP conditions are output to indicate the beginning and the end of a serial transfer.

18.3.2 Master Receiver Mode

In this case the data direction bit (R/W) will be logic 1, and it is represented by “R” in the flow diagrams. Thus the first byte transmitted is SLA+R. Serial data is received via SDA while SCL outputs the serial clock. Serial data is received 8 bits at a time. After each byte is received, an acknowledge bit is transmitted. START and STOP conditions are output to indicate the beginning and end of a serial transfer.

18.3.3 Slave Receiver Mode

Serial data and the serial clock are received through SDA and SCL. After each byte is received, an acknowledge bit is transmitted. START and STOP conditions are recognized as the beginning and end of a serial transfer. Address recognition is performed by hardware after reception of the slave address and direction bit.

18.3.4 Slave Transmitter Mode

The first byte is received and handled as in the slave receiver mode. However, in this mode, the direction bit will indicate that the transfer direction is reversed. Serial data is transmitted via SDA while the serial clock is input through SCL. START and STOP conditions are recognized as the beginning and end of a serial transfer.

18.4 Data Transfer Flow in Five Operating Modes

The five operating modes are: Master/Transmitter, Master/Receiver, Slave/Transmitter, Slave/Receiver and GC Call. Bits STA, STO and AA in I2CON register will determine the next state of the SIO hardware after SI flag is cleared. Upon completion of the new action, a new status code will be updated and the SI flag will be set. If the I2C interrupt control bits (EA and EI2C) are enable, appropriate action or software branch of the new status code can be performed in the Interrupt service routine.

Data transfers in each mode are shown in the following figures.

*** Legend for the following five figures:

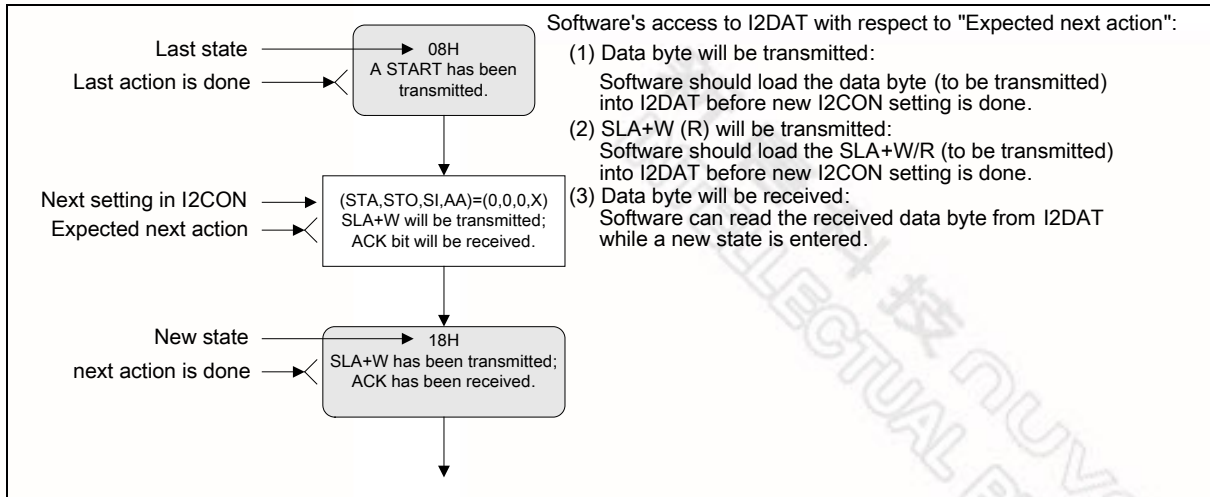

Figure 18-4 Legend for the following four figures

新唐科技 NUVOTON
INTELLECTUAL PROPERTY

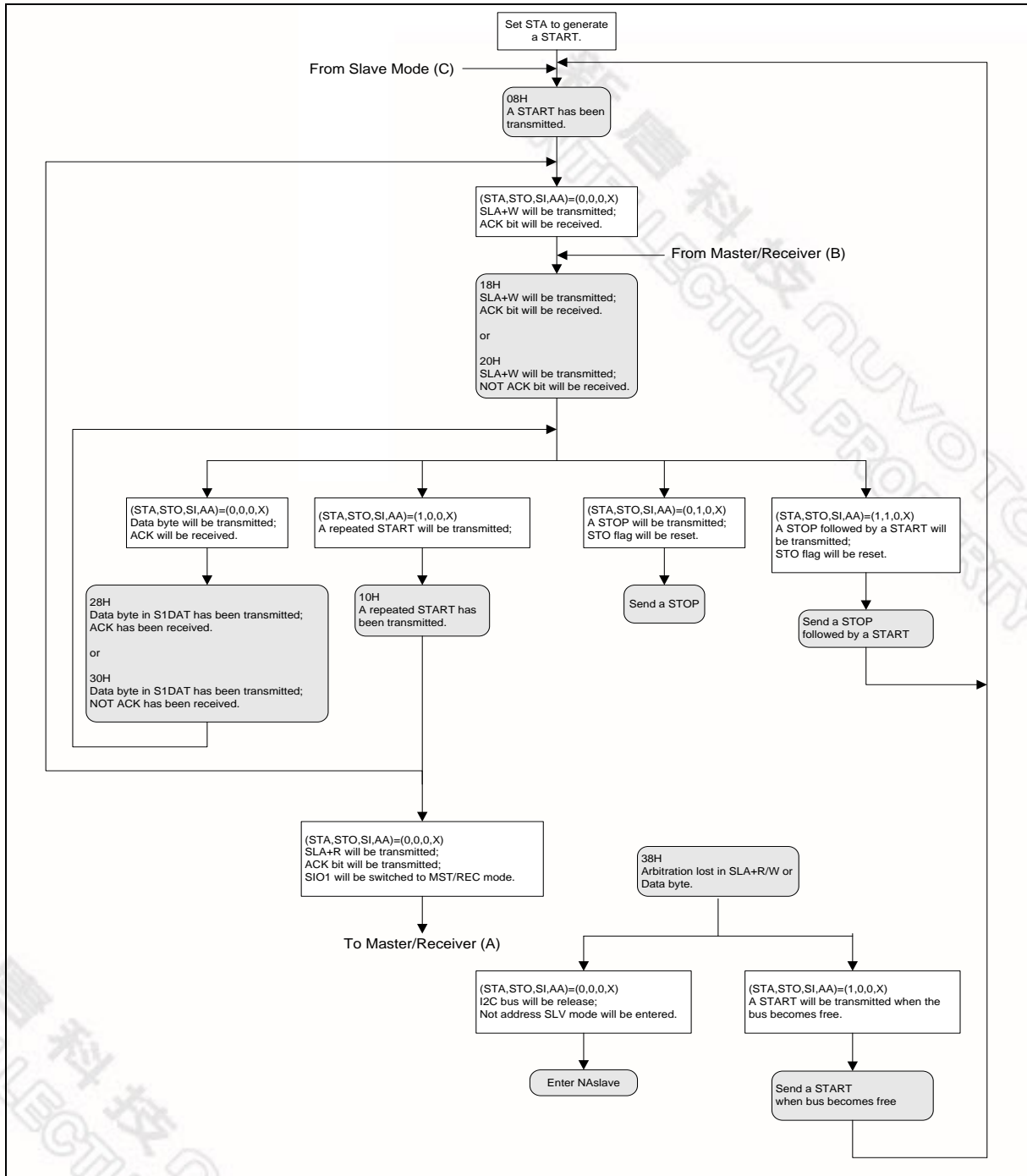

Figure 18-5 Master Transmitter Mode

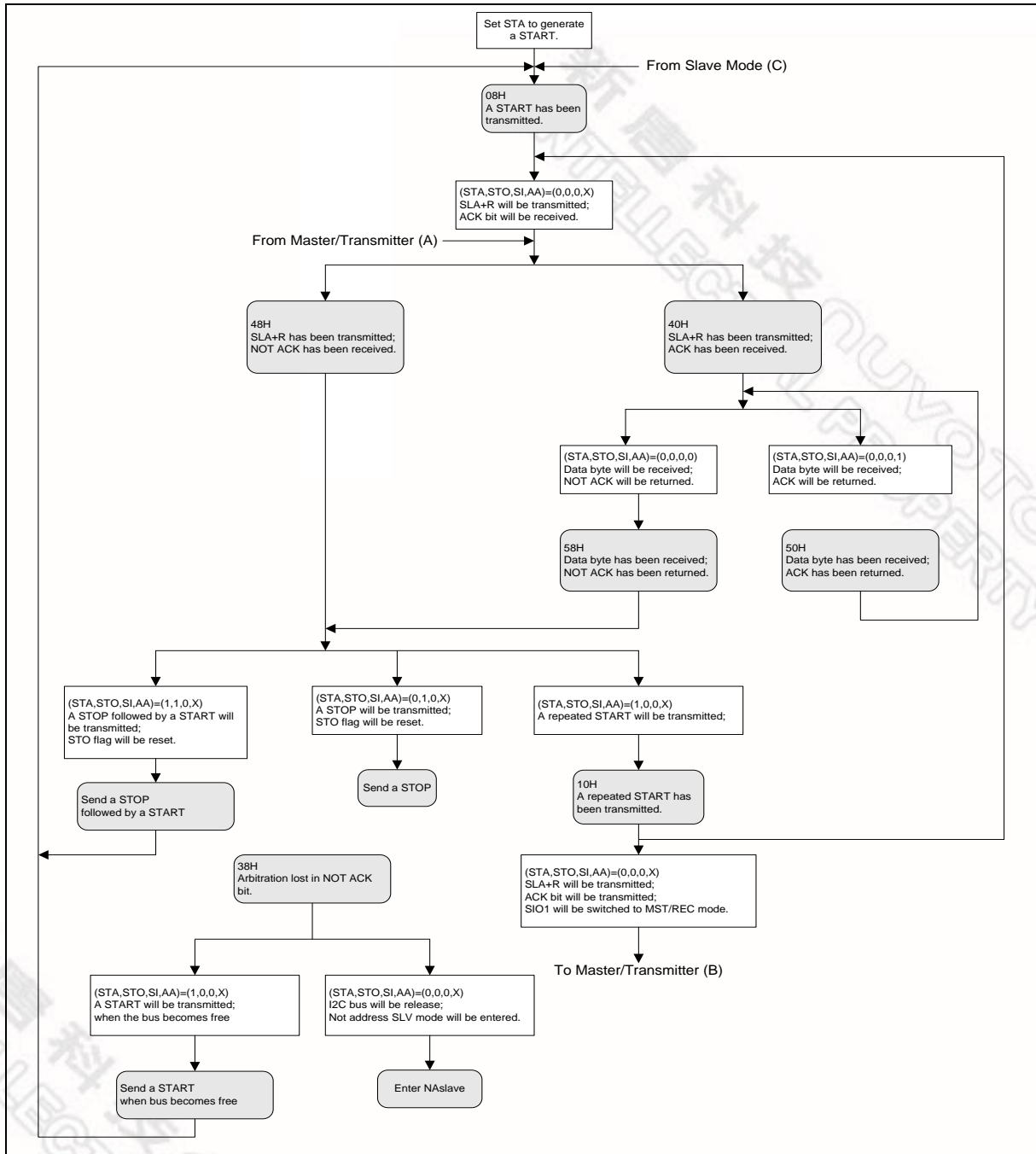

Figure 18-6 Master Receiver Mode

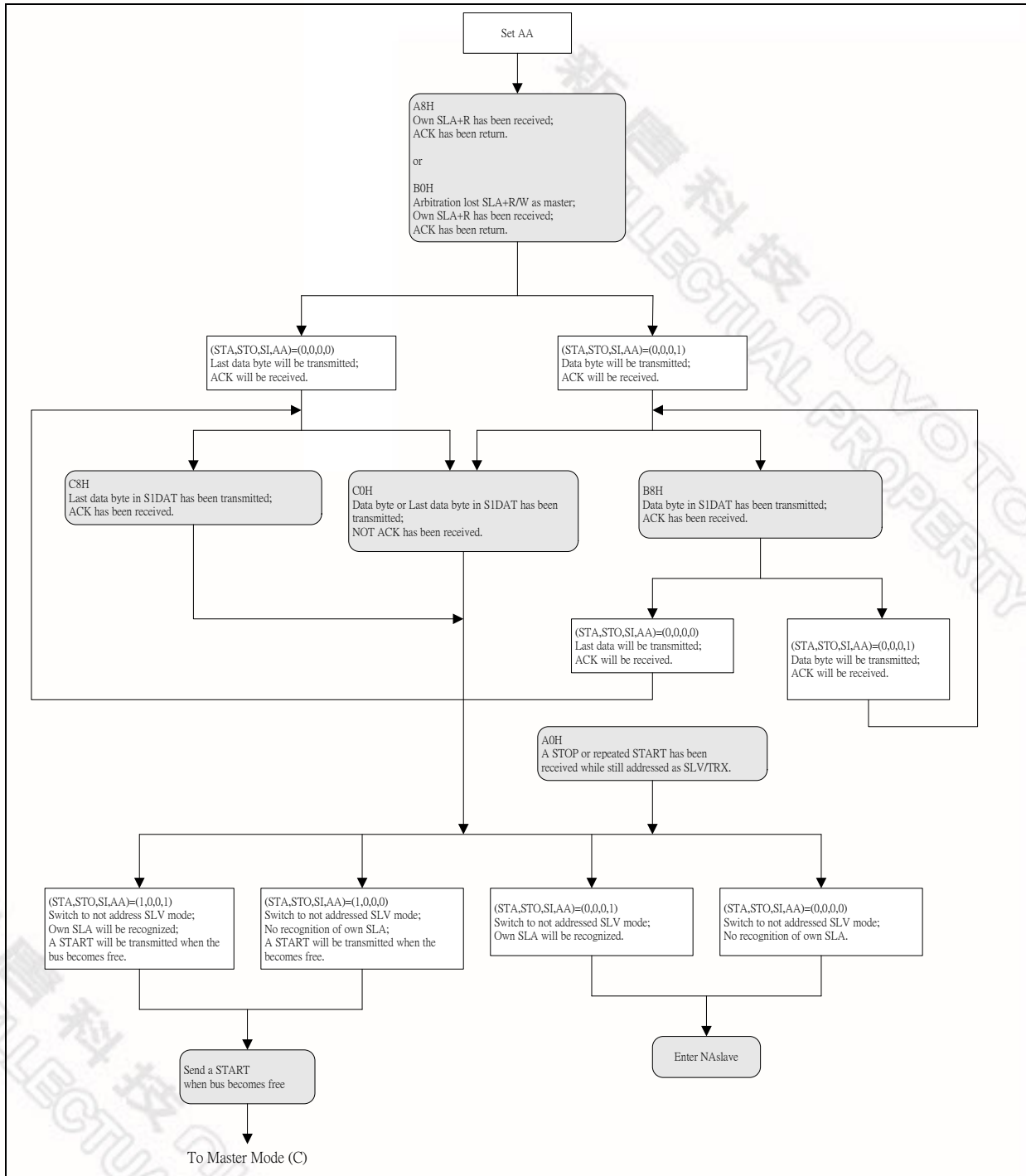

Figure 18-7 Slave Transmitter Mode

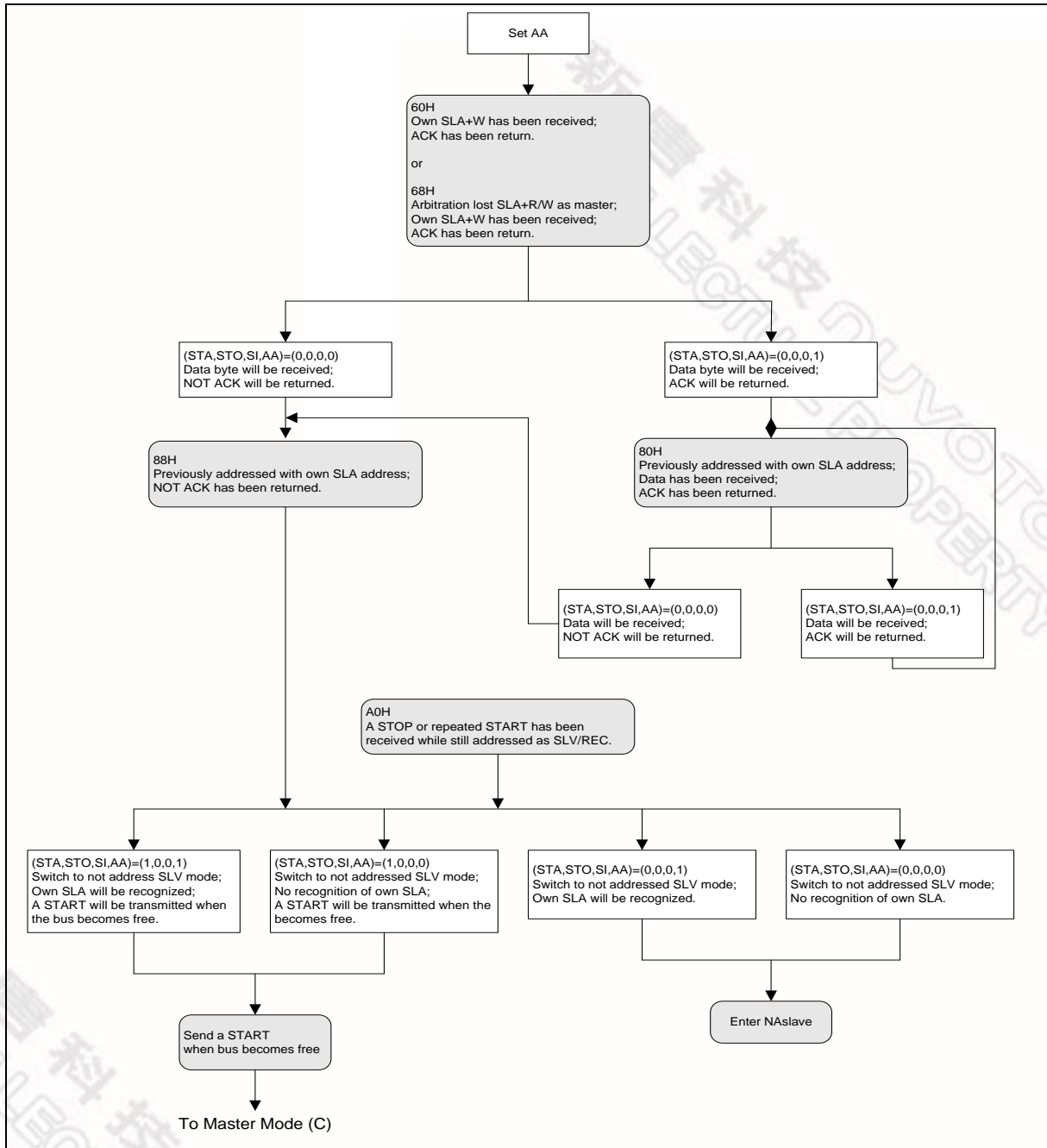

Figure 18-8 Slave Receiver Mode

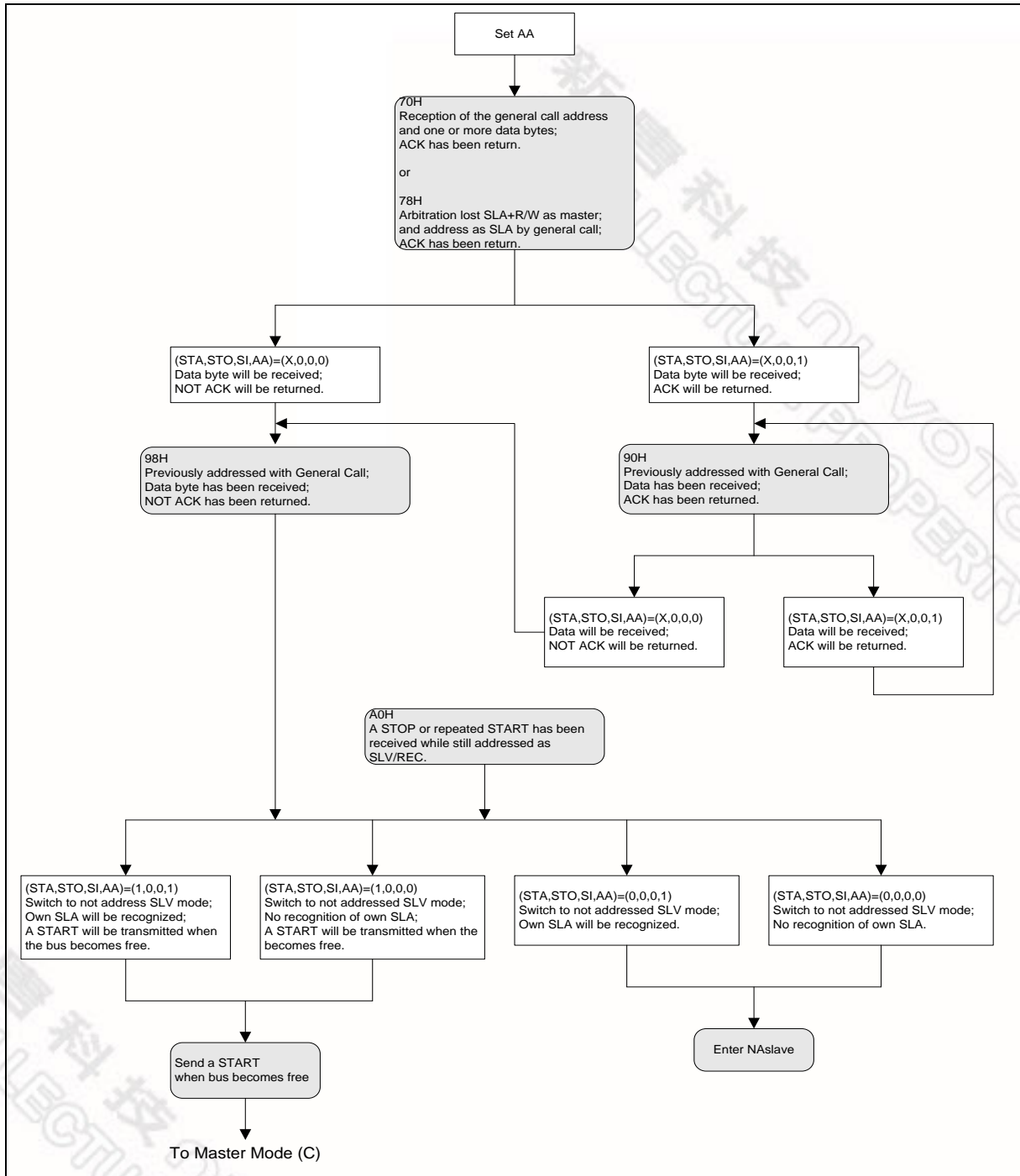

Figure 18-9 GC Mode

19 SERIAL PHERIPHERAL INTERFACE (SPI)

19.1 General descriptions

N79E875 series consist of SPI block to support high speed serial communication. It's capable of supporting data transfer rates of 2.5 Mbit/s, for 40MHz bus frequency. This device's SPI support the following features;

- Master and slave mode.
- Slave select output.
- Programmable serial clock's polarity and phase.
- Receive double buffered data register.
- MSB first(default) or LSB first selectable.
- Write collision detection.
- Transfer complete interrupt.

19.2 Block descriptions

The following figure shows SPI block diagram. It provides an overview of SPI architecture in this device. The main blocks of SPI are SPI register blocks, control logics, baud rate control, and pin control logics;

Shift register and read data buffer. It is single buffered in the transmit direction and double buffered in the receive direction. Transmit data cannot be written to the shifter until the previous transfer is complete. When the SPIF set, user will not be able to write to the shift register. User has to clear the SPIF before writing to the shift register. Receive logics consist of parallel read data buffer so the shifter is free to accept a second data, as the first received data will be transferred to the read data buffer.

SPI Control block. This provide control functions to configure the device for SPI enable, master or slave, clock phase and polarity, MSB/LSB access first selection, and Slave Select output enable.

Baud rate control. This control logics divide CPU clock to 4 different selectable clocks (1/16, 1/32, 1/64 and 1/128).

SPR1	SPR0	Divider	Baud Rate
0	0	16	2.5 Mbit/s
0	1	32	1.25 Mbit/s
1	0	64	625 Kbit/s
1	1	128	312.5 Kbit/s

Table 19-1 SPI Baud Rate Selection (based on 40 MHz Bus Clock)

SPI registers. There are three SPI registers to support its operations, they are;

- SPI control registers (SPCR)
- SPI status registers (SPSR)
- SPI data register (SPDR)

These registers provide control, status, data storage functions and baud rate selection control. Detail bit descriptions are found at SFR section.

Pin control logic. Controls behavior of SPI interface pins.

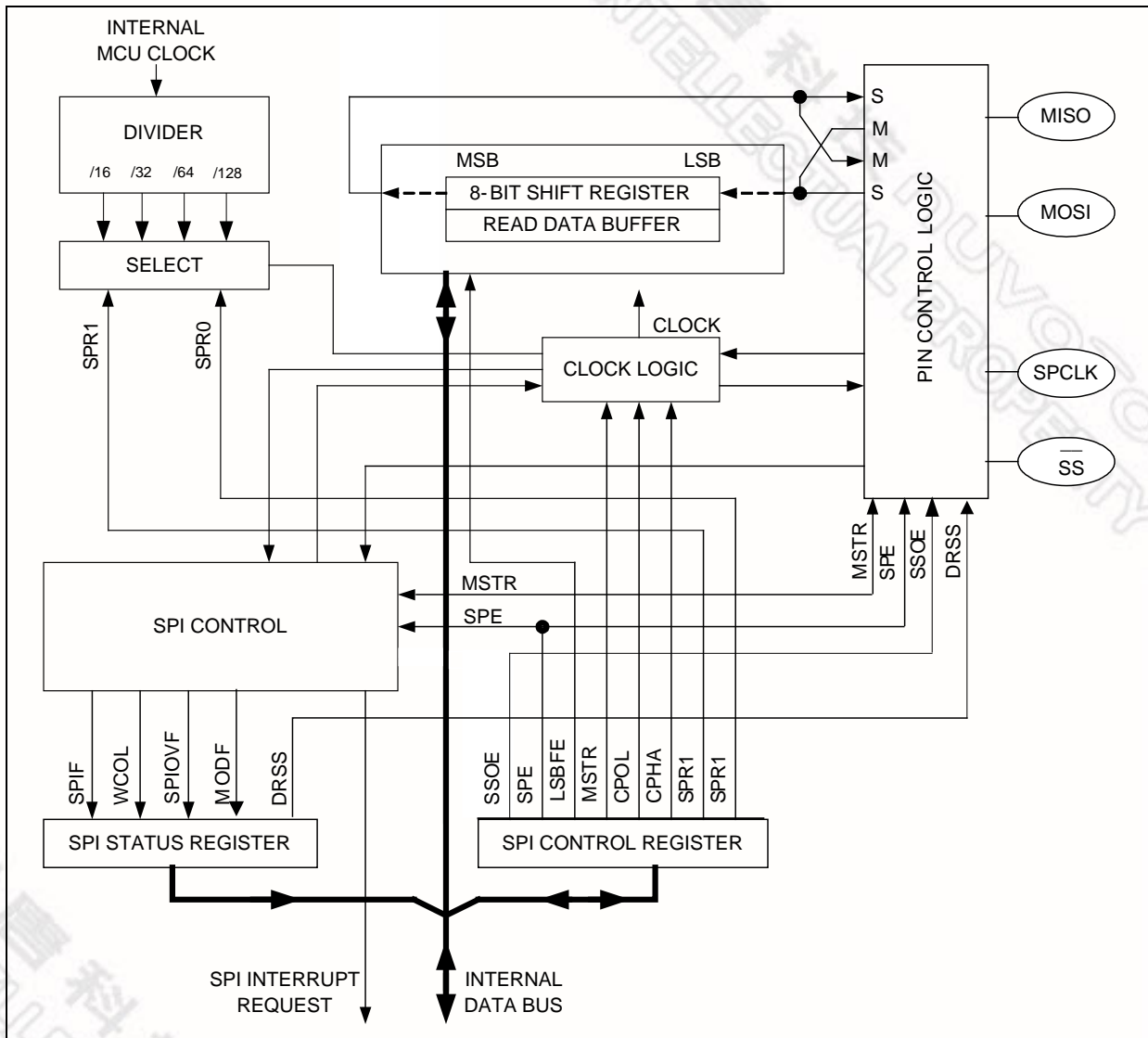

Figure 19-1 SPI block diagram

19.3 Functional descriptions

19.3.1 Master mode

The device can configure the SPI to operate as a master or as a slave, through MSTR bit. When the MSTR bit is set, master mode is selected, when MSTR bit is cleared, slave mode is selected. During master mode, only master SPI device can initiate transmission. A transmission begins by writing to the master SPDR register. The bytes begin shifting out on MOSI pin under the control of SPCLK. The master places data on MOSI line a half-cycle before SPCLK edge that the slave device uses to latch the data bit. The /SS must stay low before data transactions and stay low for the duration of the transactions.

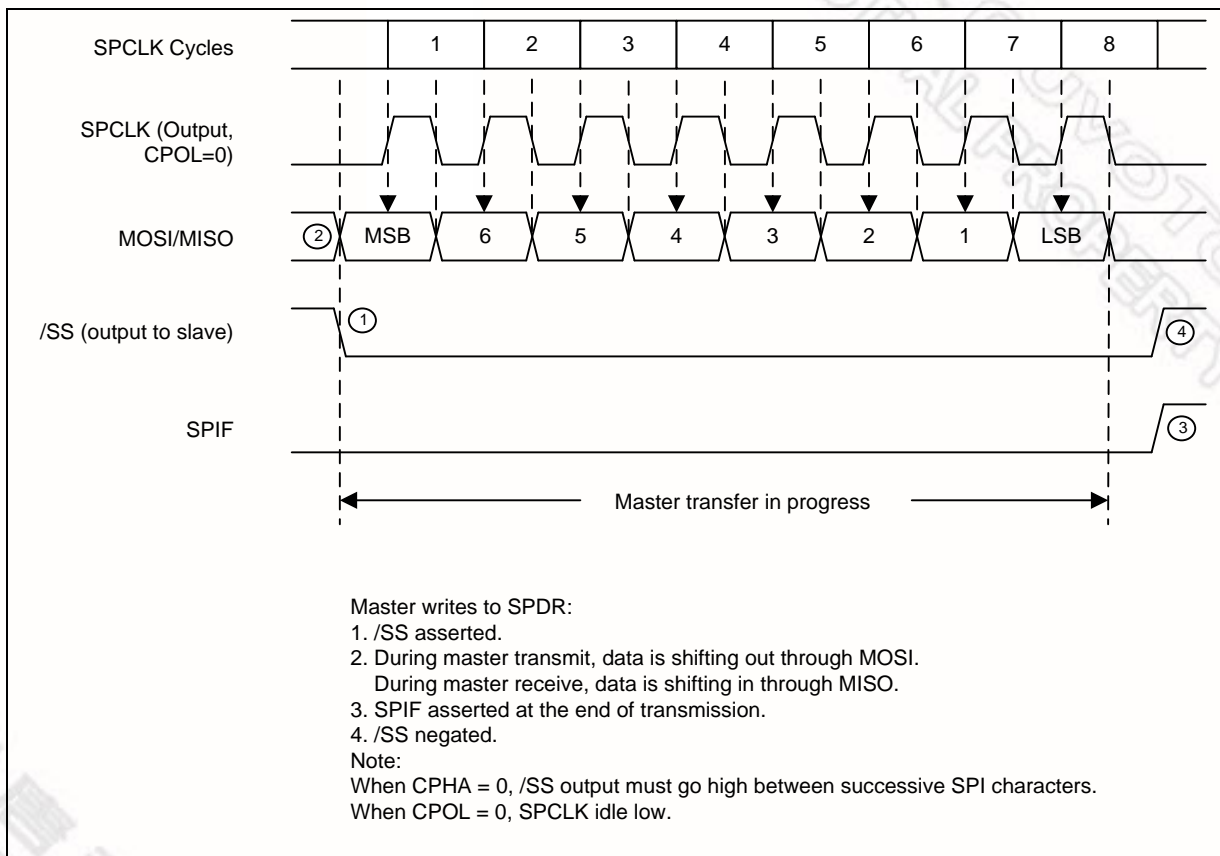

Figure 19-2 Master Mode Transmission (CPOL = 0, CPHA = 0)

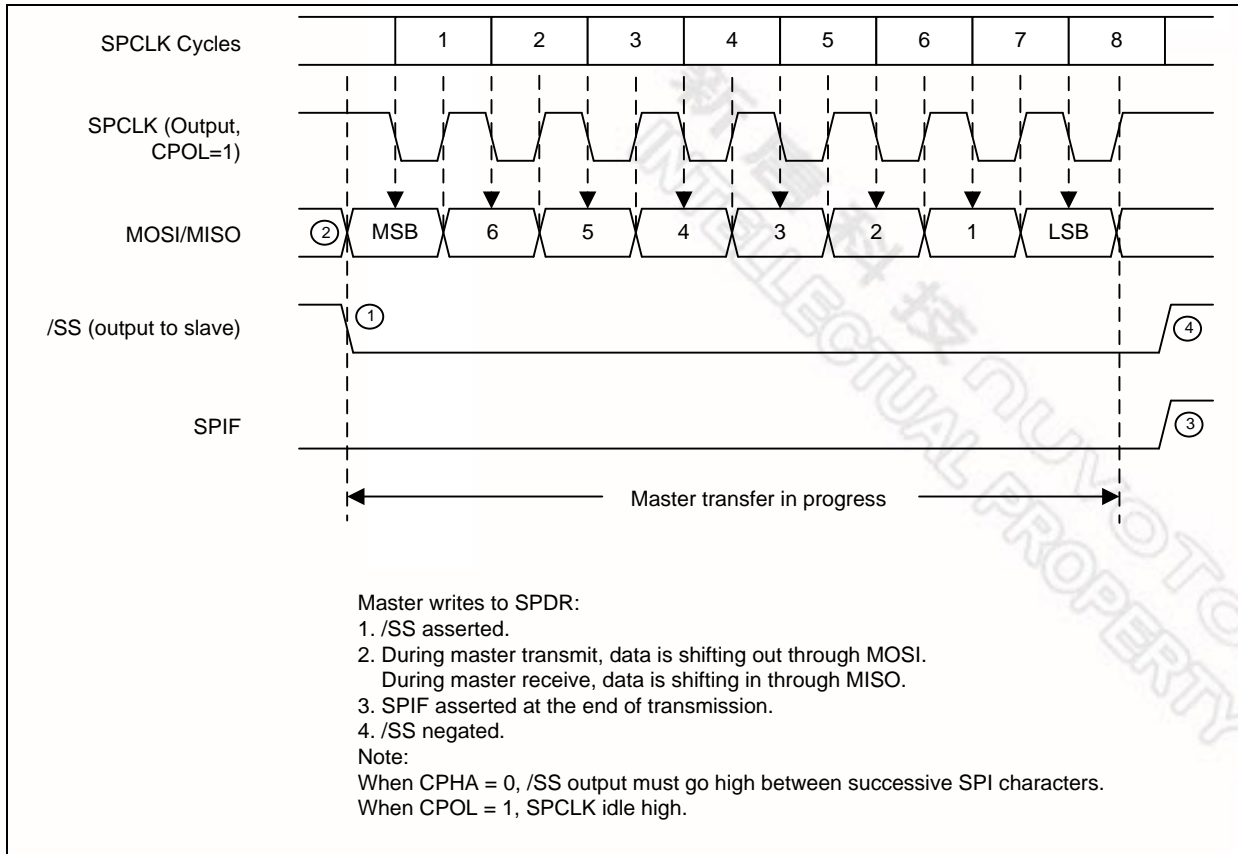

Figure 19-3 Master Mode Transmission (CPOL = 1, CPHA = 0)

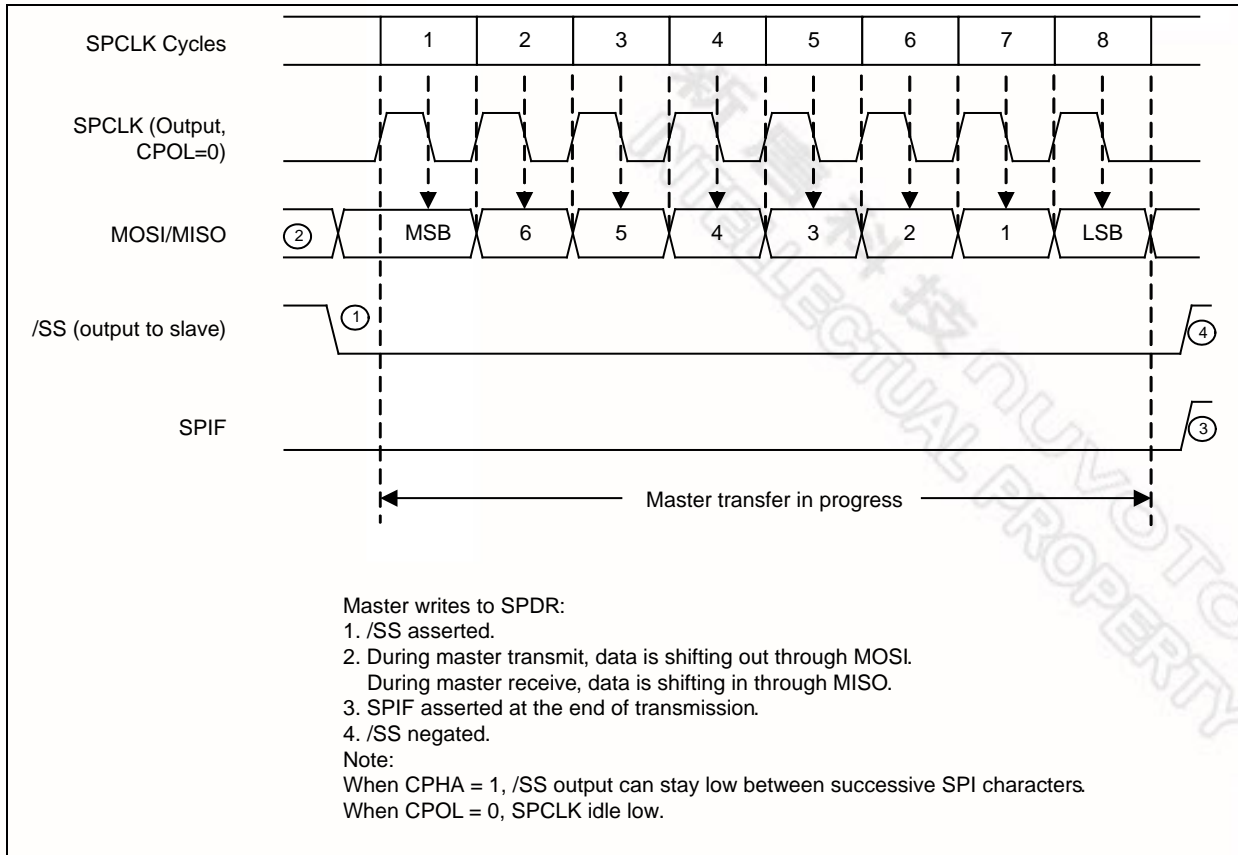

Figure 19-4 Master Mode Transmission (CPOL = 0, CPHA = 1)

新唐科技 NUVOTON
 INTELLECTUAL PROPERTY

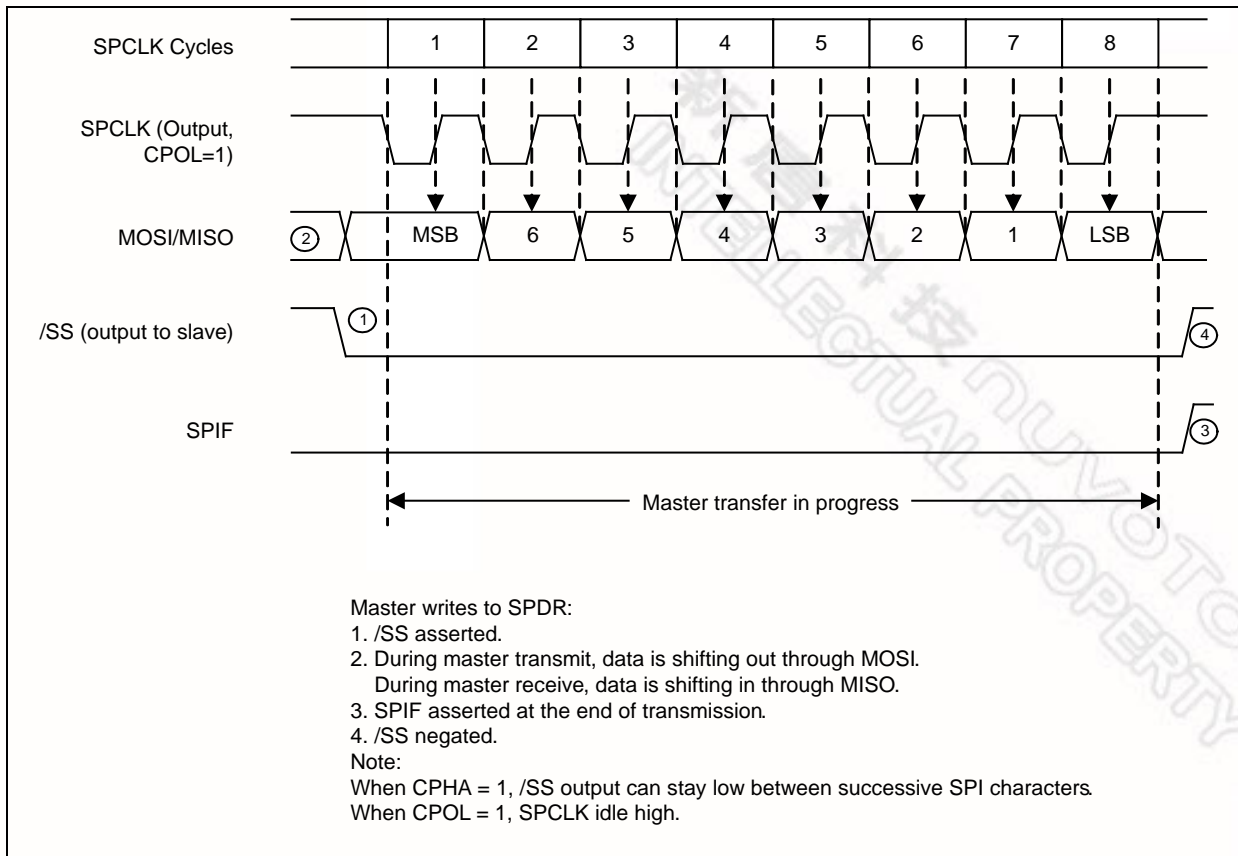

Figure 19-5 Master Mode Transmission (CPOL = 1, CPHA = 1)

19.3.2 Slave Mode

When in slave mode, the SPCLK pin becomes input and it will be clock by another master SPI device. The /SS pin also becomes input. Similarly, before data transmissions occurs, and remain low until the transmission completed. If /SS goes high, the SPI is forced into idle state.

Data flows from master to slave on MOSI pin and flows from slave to master on MISO pin. The SPDR is used when transmitting or receiving data on the serial bus. Only a write to this register initiates transmission or reception of a byte, and this only occurs in the master device. At the completion of transferring a byte of data, the SPIF status bit is set in both the master and slave devices. A read of the SPDR is actually a read of a buffer. To prevent an overrun and the loss of the byte that caused the overrun, the first SPIF must be cleared by the time a second transfer of data from the shift register to the read buffer is initiated.

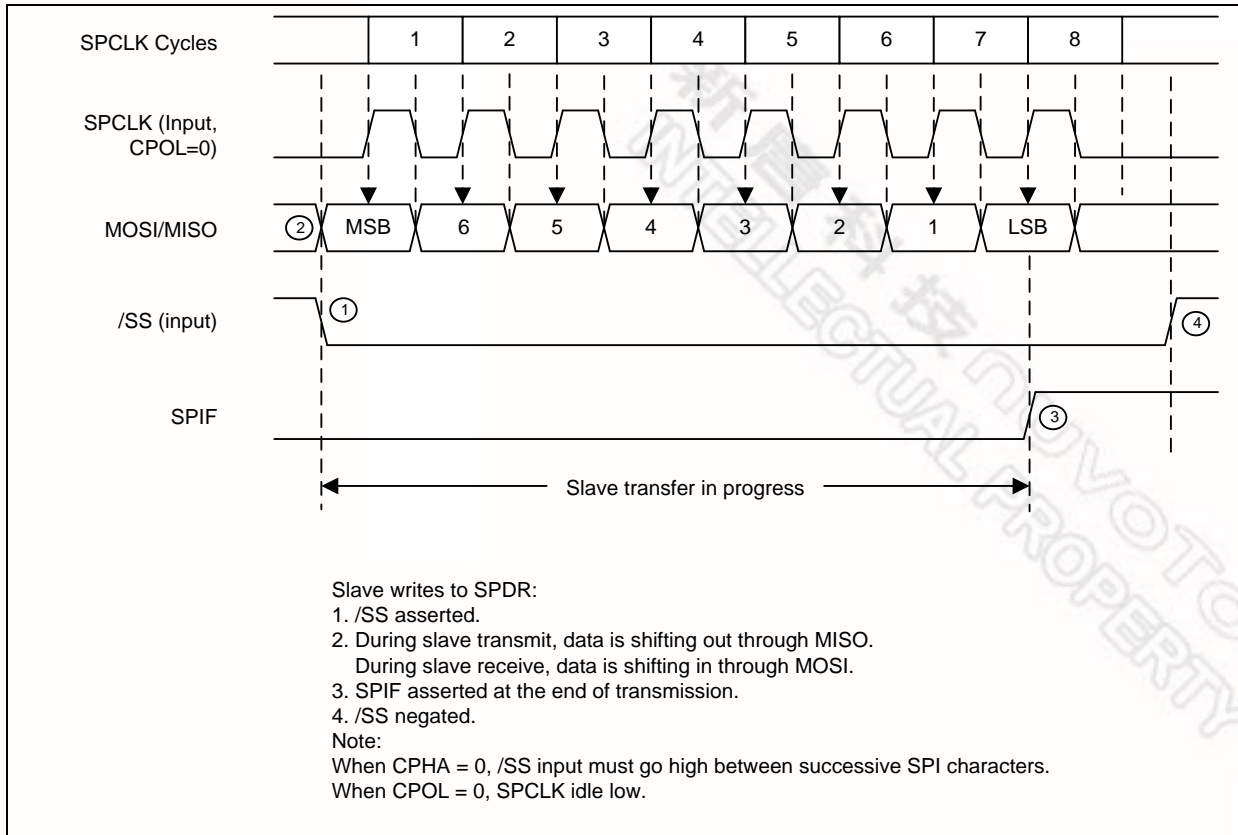

Figure 19-6 Slave Mode Transmission (CPOL = 0, CPHA = 0)

新唐科技 NUVOTON
INTELLECTUAL PROPERTY

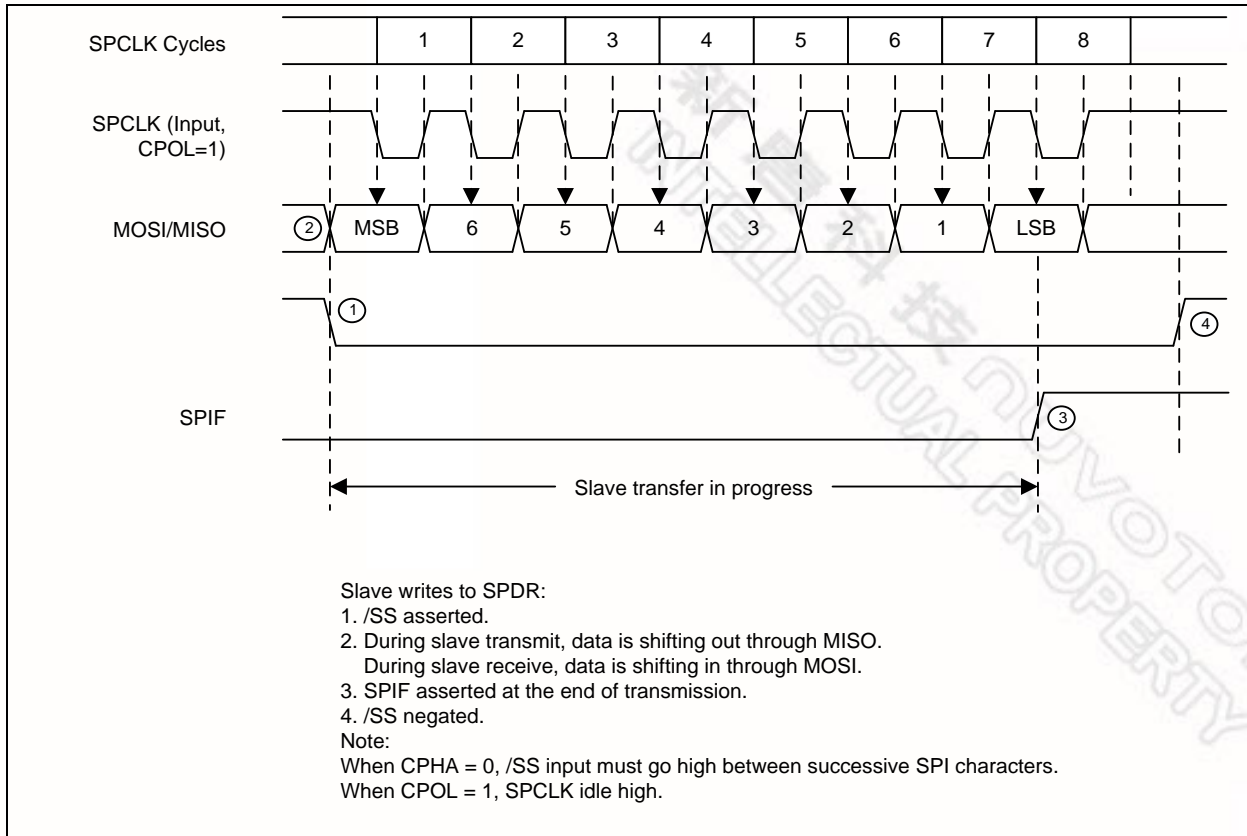

Figure 19-7 Slave Mode Transmission (CPOL = 1, CPHA = 0)

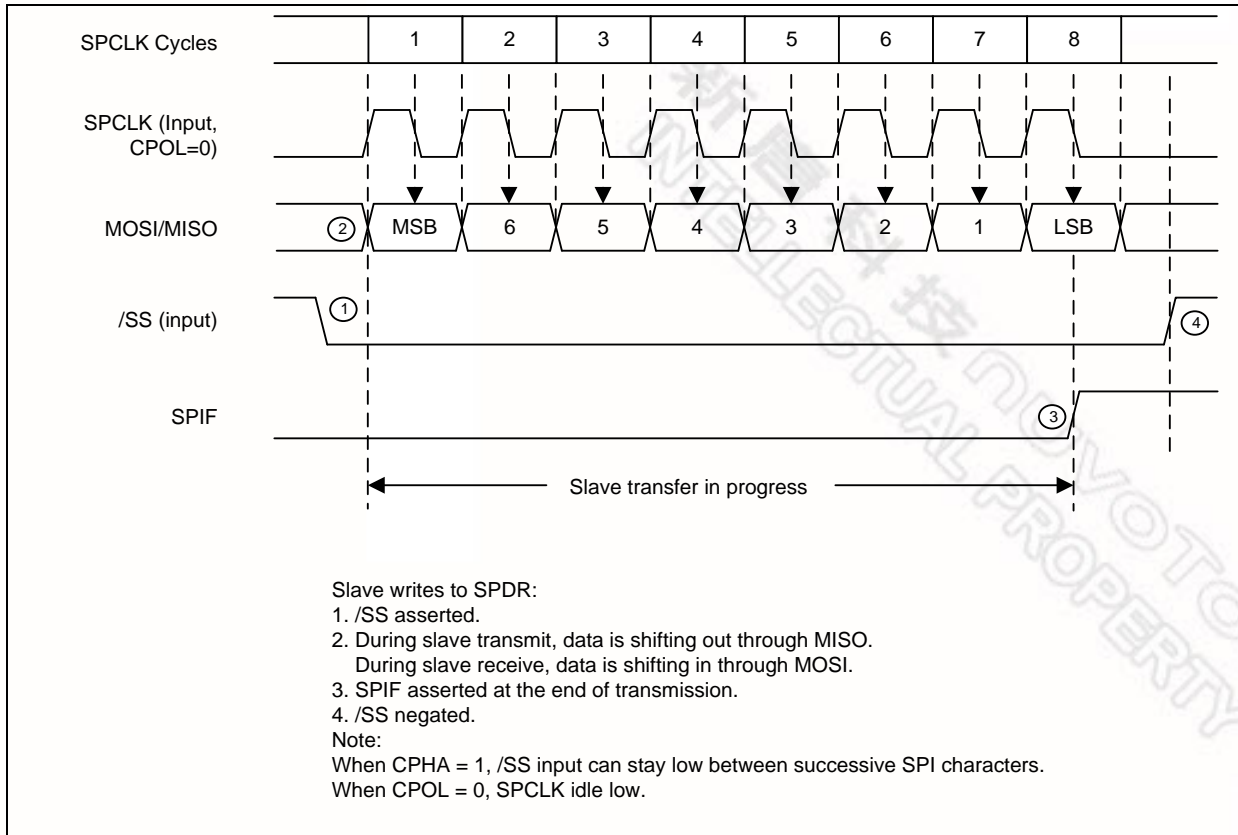

Figure 19-8 Slave Mode Transmission (CPOL = 0, CPHA = 1)

新唐科技 NUVOTON
INTELLECTUAL PROPERTY

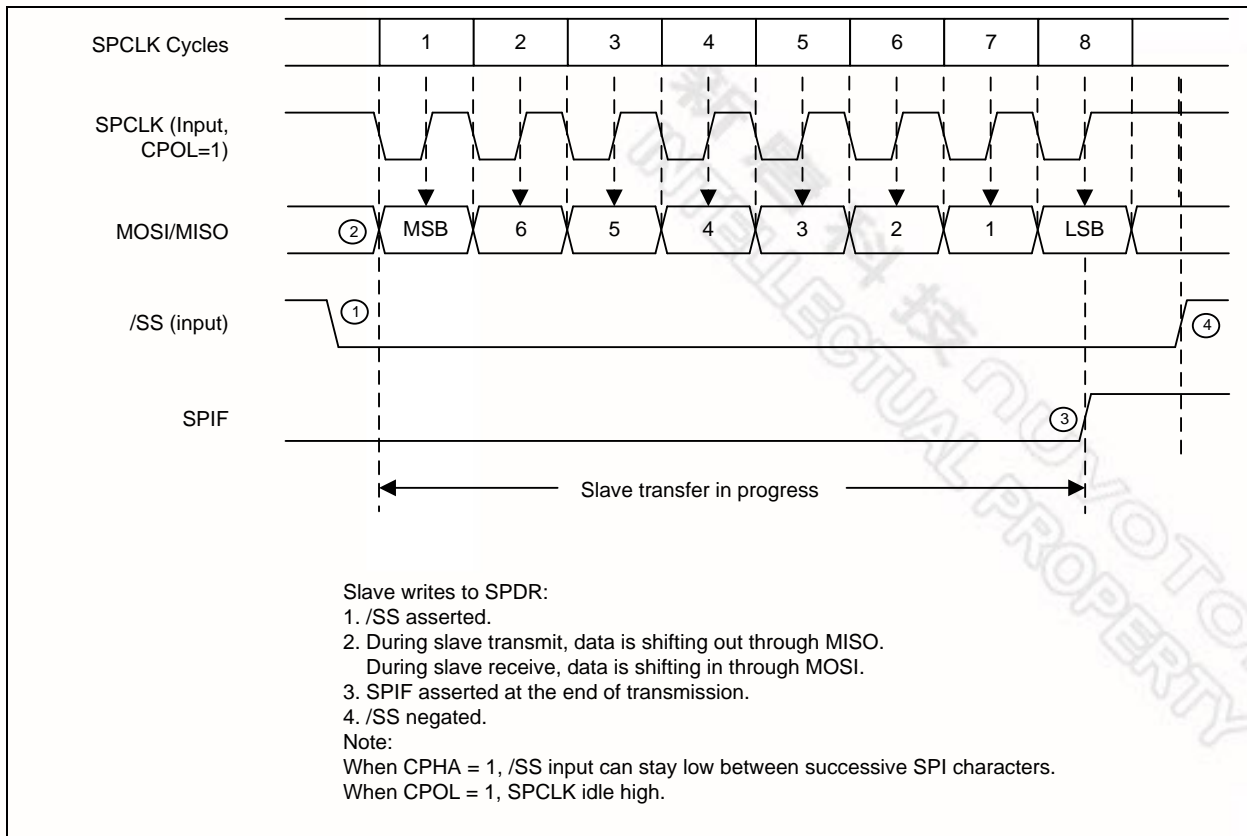

Figure 19-9 Slave Mode Transmission (CPOL = 1, CPHA = 1)

19.3.3 Slave select

The slave select (/SS) input of a slave device must be externally asserted before a master device can exchange data with the slave device. /SS must be low before data transactions and must stay low for the duration of the transaction. The /SS line of the master must be held high.

The other three lines are dedicated to the SPI whenever the serial peripheral interface is on.

The state of the master and slave CPHA bits affects the operation of /SS. CPHA settings should be identical for master and slave. When CPHA = 0, the shift clock is the OR of /SS with SCK. In this clock phase mode, /SS must go high between successive characters in an SPI message. When CPHA = 1, /SS can be left low between successive SPI characters. In cases where there is only one SPI slave MCU, its /SS line can be tied to VSS as long as only CPHA = 1 clock mode is used.

19.3.4 Slave Select output enable

Available in master mode only, the /SS output is enabled with the SSOE bit in the SPCR register. The /SS output pin is connected to the /SS input pin of the slave device. The /SS output automatically goes low for each transmission when selecting external device and it goes high during each idling state to deselect external devices.

DRSS	SSOE	Master Mode	Slave Mode
0	0	/SS input (With Mode Fault). See section SPI I/O mode section for detail.	/SS Input (Not affected by SSOE)

0	1	Reserved	/SS Input (Not affected by SSOE)
1	0	/SS General purpose I/O (No Mode Fault)	/SS Input (Not affected by SSOE)
1	1	/SS output (No Mode Fault)	/SS Input (Not affected by SSOE)

Table 19-2 /SS output

During master mode (with SSOE=DRSS= 0), mode fault will be set if /SS pin is detected low. When mode fault is detected hardware will clear MSTR bit and SPE bit in the meantime it will also generated interrupt request, if ESPI is enabled.

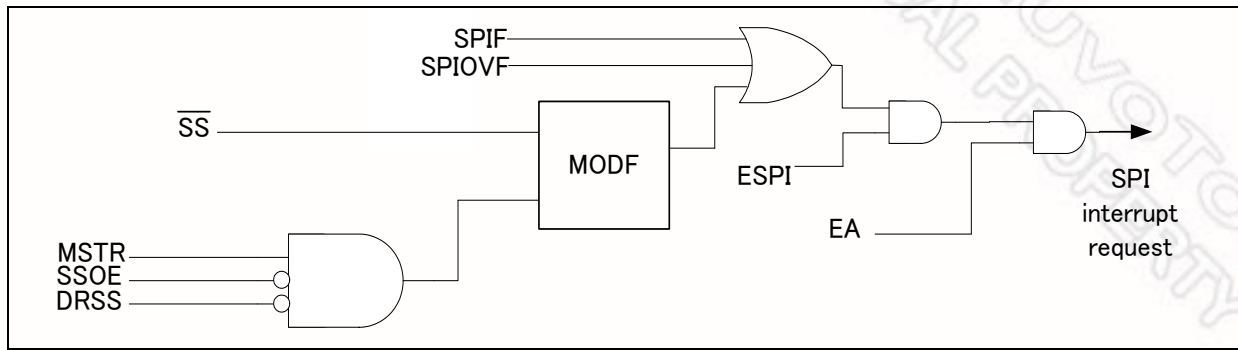

Figure 19-10 SPI interrupt request

19.3.5 SPI I/O pins mode

When SPI is disabled (SPE = 0) the corresponding I/O is following the setting determined by port mode setting (SFR P2M1 & P2M2). When SPI is enabled (SPE = 1) the SPI pins I/O mode follow the below table. For /SS pin it is always at Quasi-bidirectional mode whether it is configured as master or slave.

	MISO	MOSI	CLK	/SS
Master	Input	Output	Output	Output^[1] : DRSS=1,SSOE=1 Input : DRSS=0, SSOE=0
Slave	Output^[2] during /SS = Low Else Input mode	Input	Input	Input

Table 19-3 SPI I/O pins mode

Input = Quasi-bidirectional mode; Output = Push-pull mode

Output^[1] = This output mode in /SS is Quasi-bidirectional output mode. Master needs to detect mode fault during master outputs /SS low.

Output^[2] = In SLAVE mode, MISO is in output mode only during the time of /SS =Low. Otherwise it must keep in input mode (Quasi-bidirectional).

19.3.6 Programmable serial clock's phase and polarity

The clock polarity SPCR.CPOL control bit selects active high or active low SCK clock, and has no significant effect on the transfer format. The clock phase SPCR.CPHA control bit selects one of two different transfer protocols by sampling data on odd numbered SCK edges or on even numbered SCK edges. Thus, both these bits enable selection of four possible clock formats to be used by SPI system.

The clock phase and polarity should be identical for the master SPI device and the communicating slave device.

When CPHA equals 0, the /SS line must be negated and reasserted between each successive serial byte. Also, if the slave writes data to the SPI data register (SPDR) while /SS is low, a write collision error results. When CPHA equals 1, the /SS line can remain low between successive transfers.

When CPHA = 0, data is sample on the first edge of SPCLK and when CPHA = 1 data is sample on the second edge of the SPCLK. Prior to changing CPOL setting, SPE must be disabled first.

19.3.7 Receive double buffered data register

This device is single buffered in the transmit direction and double buffered in the receive direction. This means that new data for transmission cannot be written to the shifter until the previous transfer is complete; however, received data is transferred into a parallel read data buffer so the shifter is free to accept a second serial byte. As long as the first byte is read out of the read data buffer before the next byte is ready to be transferred, no overrun condition occurs.

If overrun occur, SPIOVF is set. Second byte serial data cannot be transferred successfully into the data register during overrun condition and the data register will remains the value of the previous byte. The figure below shows the receive data timing waveform when overrun occur.

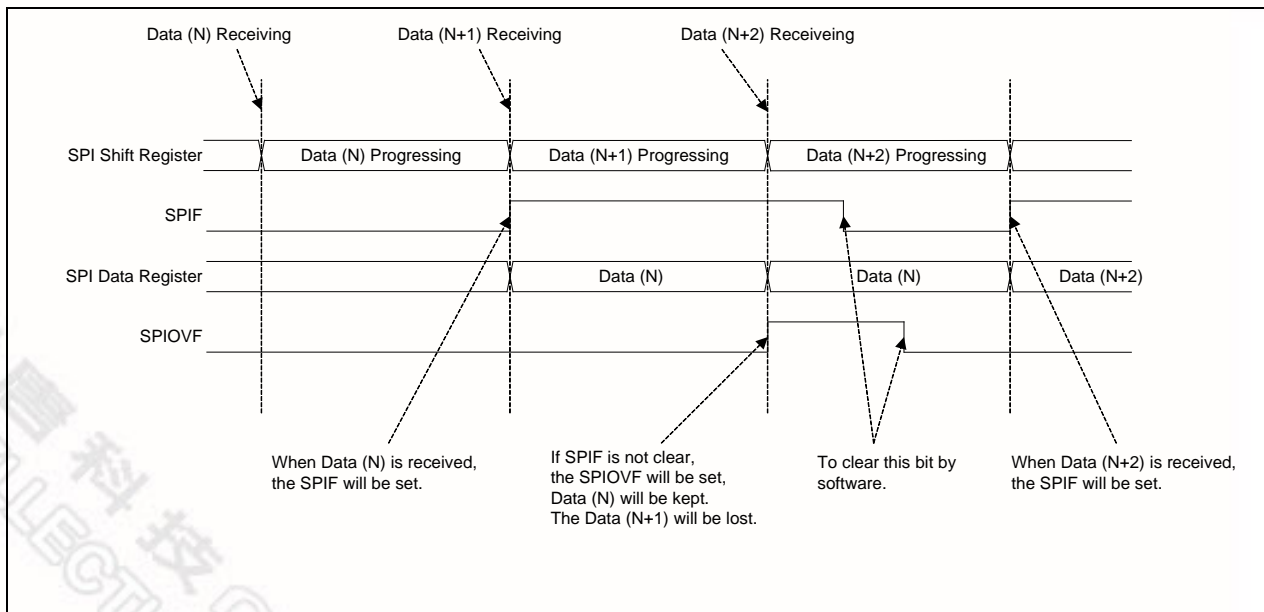

Figure 19-11 SPI receive data timing waveform

19.3.8 LSB first enable

By default, this device transfer the SPI data most significant bit first. This device provides a control bit SPCR.LSBFE to allow support of transfer of SPI data in least significant bit first.

19.3.9 Write Collision detection

Write collision indicates that an attempt was made to write data to the SPDR while a transfer was in progress. SPDR is not double buffered in the transmit direction, any writes to SPDR cause data to be written directly into the SPI shift register. This write corrupts any transfer in progress, a write collision error is generated (WCOL will be set). The transfer continues undisturbed, and the write data that caused the error is not written to the shifter. A write collision is normally a slave error because a slave has no control over when a master initiates a transfer. A master knows when a transfer is in progress, so there is no reason for a master to generate a write-collision error, although the SPI logic can detect write collisions in both master and slave devices.

WCOL flag is clear by software.

19.3.10 Transfer complete interrupt

This device consists of an interrupt flag at SPSR.SPIF. This flag will be set upon completion of data transfer with external device, or when a new data have been received and copied to SPDR. If interrupt is enable (through ESPI located at EIE2.3), the SPI interrupt request will be generated, if global enable is also enabled. SPIF is a software clear interrupt.

19.3.11 Mode Fault

Error arises in a multiple-master system when more than one SPI device simultaneously tries to be a master. This error is called a mode fault.

When the SPI system is configured as a master and the /SS input line goes to active low, a mode fault error has occurred — usually because two devices have attempted to act as master at the same time. In cases where more than one device is concurrently configured as a master, there is a chance of contention between two pin drivers. For push-pull CMOS drivers, this contention can cause permanent damage. The mode fault mechanism attempts to protect the device by disabling the drivers. The MSTR & SPE control bits in the SPCR associated with the SPI are cleared and an interrupt is generated subject to masking by the ESPI control bit.

Other precautions may need to be taken to prevent driver damage. If two devices are made masters at the same time, mode fault does not help protect either one unless one of them selects the other as slave. The amount of damage possible depends on the length of time both devices attempt to act as master.

MODF bit is set automatically by SPI hardware, if the MSTR control bit is set and the slave select input pin becomes 0. This condition is not permitted in normal operation. In the case where /SS is set, it is an output pin rather than being dedicated as the /SS input for the SPI system. In this special case, the mode fault function is inhibited and MODF remains cleared. This flag is cleared by software.

The following figures show the sample hardware connection for multi-master/slave environment, and flow diagram which shows how s/w handles mode fault.

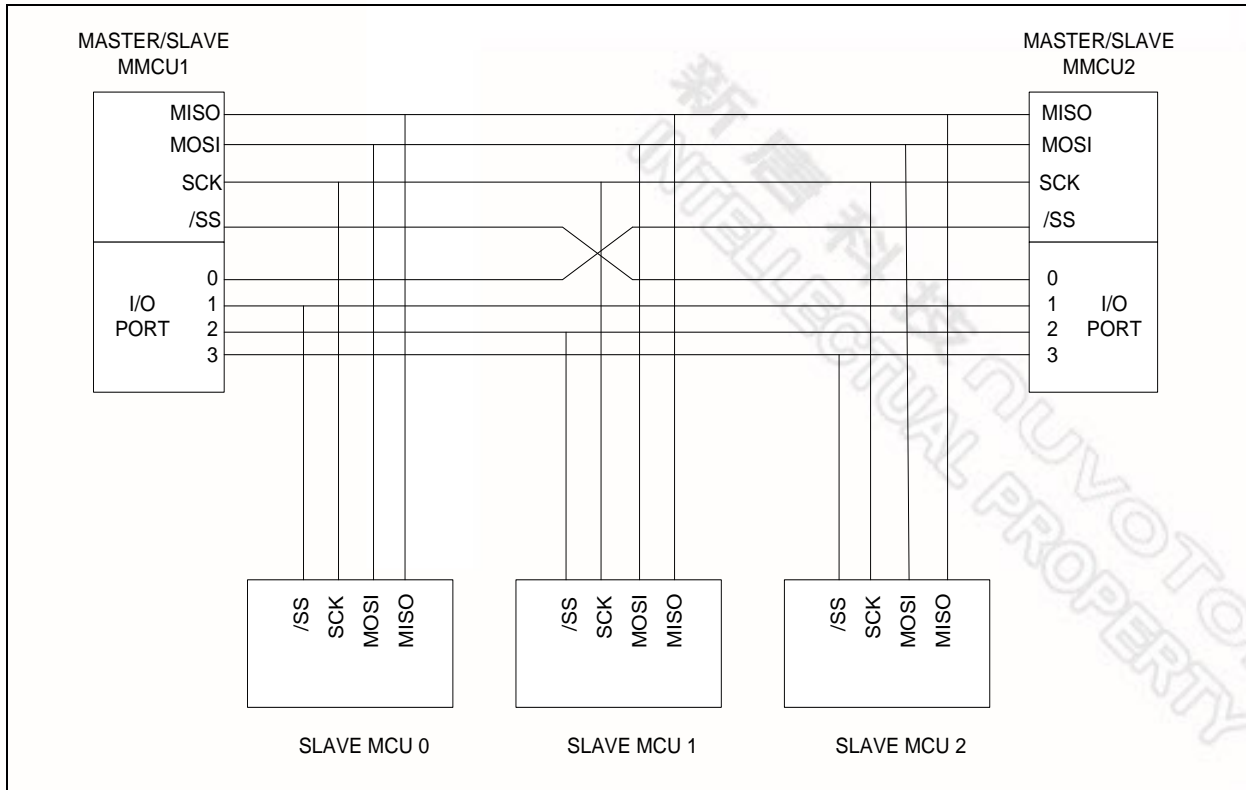

Figure 19-12 SPI multi-master slave environment

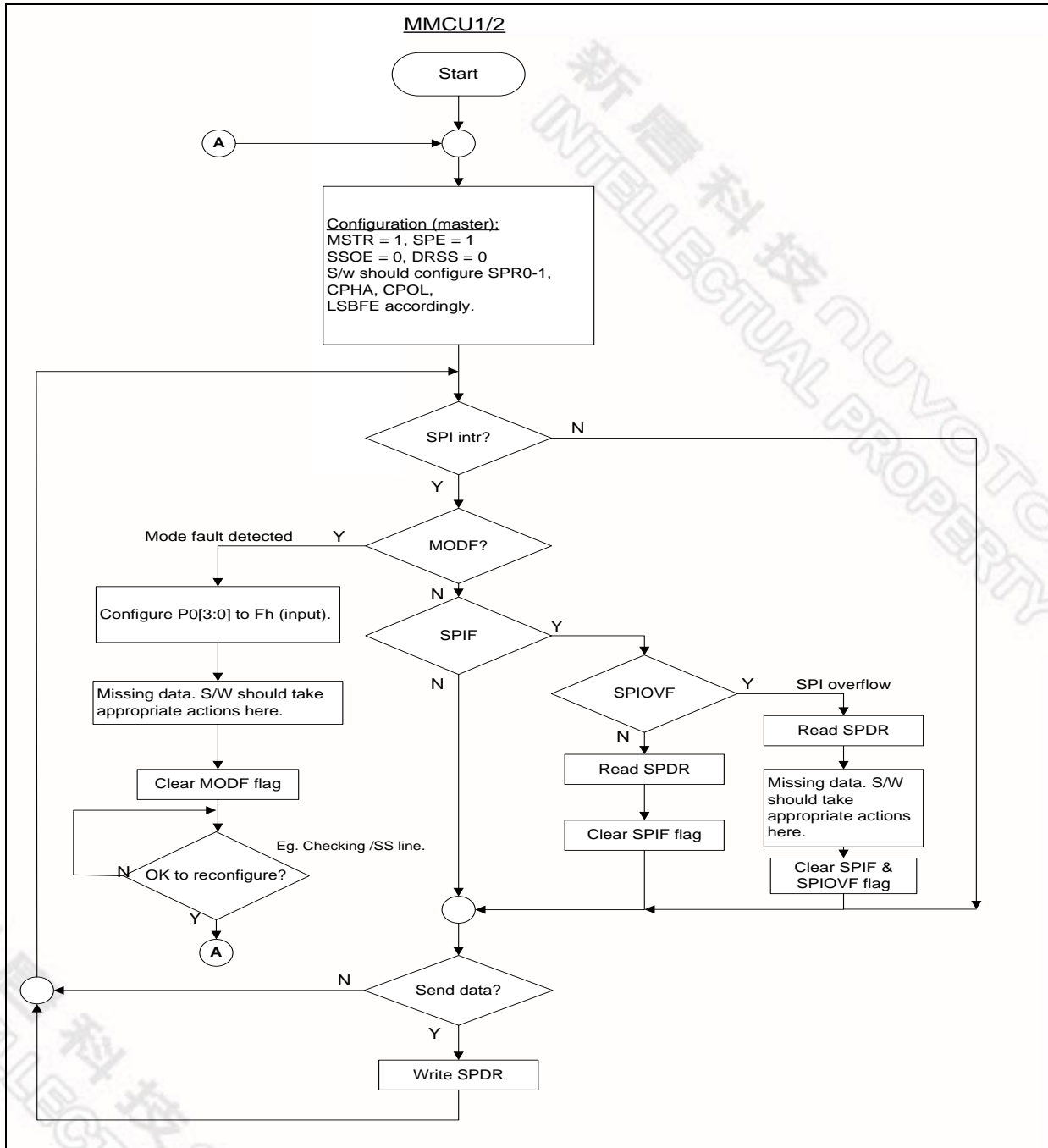

Figure 19-13 SPI multi-master slave s/w flow diagram

20 TIMED ACCESS PROTECTION

In this MCU, some functions are crucial to proper operation of the system like the Watchdog Timer. If left unprotected, errant code may write to the Watchdog control bits resulting in incorrect operation and loss of control. In order to prevent this, it has a protection scheme which controls the write access to critical bits. This protection scheme is done using a timed access.

There registers, PDTC0(AEh), DTCNT(ABh) and WDCON(D8h) have the timed access protection when CPU has a write access to one of the three registers.

In this method, the bits which are to be protected have a timed write enable window. A write is successful only if this window is active, otherwise the write will be discarded. This write enable window is open for 3 machine cycles if certain conditions are met. After 3 machine cycles, this window automatically closes. The window is opened by writing AAh and immediately 55h to the Timed Access (TA) SFR. This SFR is located at address C7h. The suggested code for opening the timed access window is

```

    TA          REG          0C7h          ; Define new register TA, located at 0C7h
                MOV          TA, #0AAh
                MOV          TA, #055h
    
```

When the software writes AAh to the TA SFR, a counter is started. This counter waits for 3 machine cycles looking for a write of 55h to TA. If the second write (55h) occurs within 3 machine cycles of the first write (AAh), then the timed access window is opened. It remains open for 3 machine cycles, during which the user may write to the protected bits. Once the window closes the procedure must be repeated to access the other protected bits.

Examples of Timed Accessing are shown below.

Example 1: Valid access

```

    MOV          TA, #0AAh          ; 3 M/C; Note: M/C = Machine Cycles
    MOV          TA, #055h          ; 3 M/C
    MOV          WDCON, #00h        ; 3 M/C
    
```

Example 2: Valid access

```

    MOV          TA, #0AAh          ; 3 M/C
    MOV          TA, #055h          ; 3 M/C
    NOP                          ; 1 M/C
    SETB         EWRST              ; 2 M/C
    
```

Example 3: Valid access

```

    MOV          TA, #0AAh          ; 3 M/C
    MOV          TA, #055h          ; 3 M/C
    ORL          WDCON, #00000010B ; 3M/C
    
```

Example 4: Invalid access

```

    MOV          TA, #0AAh          ; 3 M/C
    MOV          TA, #055h          ; 3 M/C
    
```



NOP			; 1 M/C
NOP			; 1 M/C
CLR	EWT		; 2 M/C

Example 5: Invalid Access

MOV	TA, #0AAh		; 3 M/C
NOP			; 1 M/C
MOV	TA, #055h		; 3 M/C
SETB	EWT		; 2 M/C

In the first three examples, the writing to the protected bits is done before the 3 machine cycles' window closes. In Example 4, however, the writing to the protected bit occurs after the window has closed, and so there is effectively no change in the status of the protected bit. In Example 5, the second write to TA occurs 4 machine cycles after the first write, therefore the timed access window is not opened at all, and the write to the protected bit fails.

21 KEYBOARD INTERRUPT (KBI)

The N79E875 series provide 8 keyboard interrupt function to detect keypad status which key is acted, and allow a single interrupt to be generated when any key is pressed on a keyboard or keypad connected to specific pins of the N79E875 series, as shown below figure. This interrupt may be used to wake up the CPU from Idle or Power Down modes, after chip is in Power Down or Idle Mode.

Keyboard function is supported through by Port 0. It can allow any or all pins of Port 0 to be enabled to cause this interrupt. Port pins are enabled by the setting of bits of KBI0 ~ KBI7 in the KBI register, as shown below figure. The Keyboard Interrupt Flag, KBF in the AUXR1(A2H).7, is set when any enabled pin is triggered while the KBI interrupt function is active, an interrupt will be generated if it has been enabled. The KBF bit set by hardware and must be cleared by software. In order to determine which key was pressed, the KBI will allow the interrupt service routine to poll port 0.

KBI1~KBI3 support both rising and falling edge detection, and the remaining pins support low level detection only.

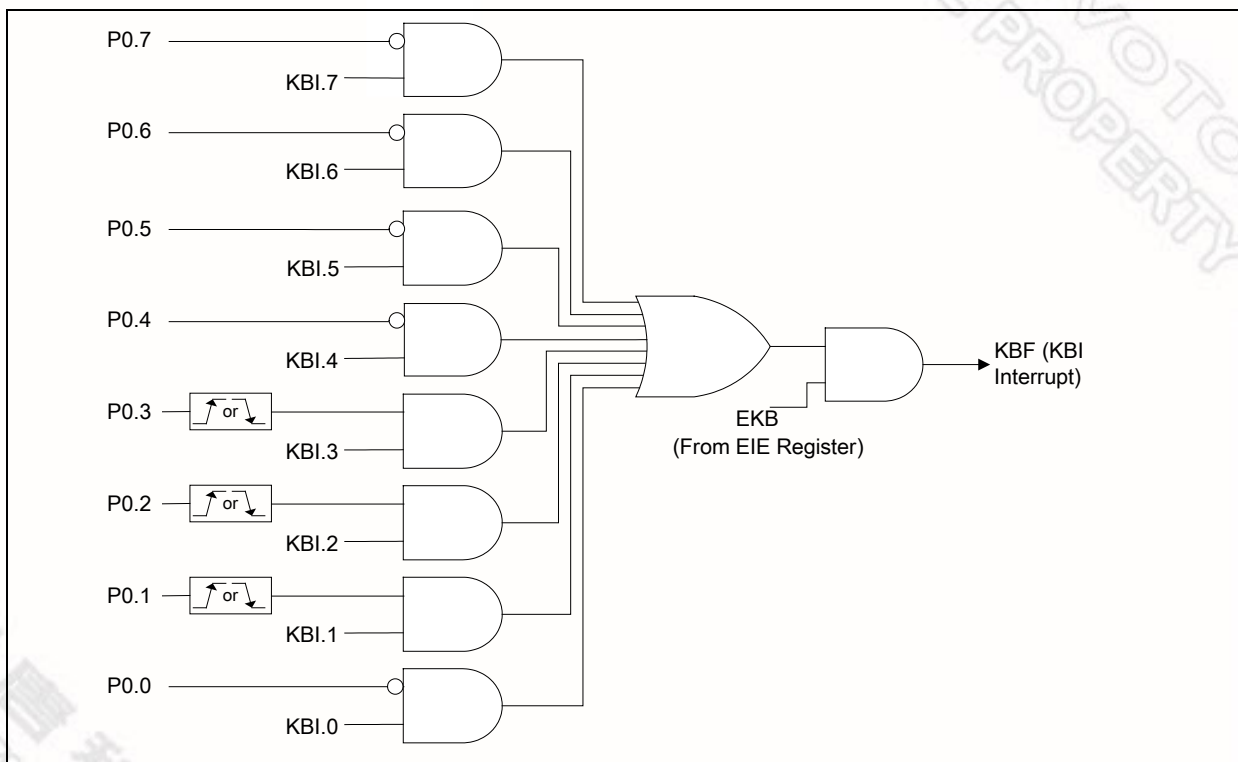

Figure 21-1: KBI inputs

SYMBOL	DEFINITION	ADDRESS	BIT ADDRESS, SYMBOL								LSB	RESET
			MSB									
AUXR1	AUX FUNCTION REGISTER 0	A2H	KBF	BOD	BOI	LPBOD	SRST	ADCEN	RCCLK	BOS	0X00 0000B	
KBI	KEYBOARD INTERRUPT	A1H	KBI.7	KBI.6	KBI.5	KBI.4	KBI.3	KBI.2	KBI.1	KBI.0	0000 0000B	



22 I/O PORT CONFIGURATION

N79E875 series have maximum **four** 8 bits I/O ports; port 0, port 1, port 2, port 3 and **one** partial port 4; P4.0 to P4.3. All pins of I/O ports can be configured to one of four types by software except **P1.4** is only input pin or set to reset pin. When P1.4 is configured reset pin by RPD=0 in the CONFIG0 register, the device can support 33 I/O pins by use Crystal. If used on-chip RC oscillator and the P1.4 is configured input pin, the device can be supported up to 36 I/O pins. The I/O ports configuration setting as below table.

PxM1.y	PxM2.y	Port Input/Output Mode
0	0	Quasi-bidirectional
0	1	Push-Pull
1	0	Input Only (High Impedance)
1	1	Open Drain

Table 22-1: I/O port configuration table

All port pins can be determined to high or low after reset by configure PRHI bit in the CONFIG0 register. After reset, these pins are in quasi-bidirectional mode. The port pin of P1.4 only is a Schmitt trigger input.

Enabled toggle outputs from Timer 0 and Timer 1 by **T0OE and T1OE on AUXR2** register, the output frequency of Timer 0 or Timer 1 is by Timer overflow.

Each I/O port of N79E875 series may be selected to use TTL level inputs or Schmitt inputs by **P(n)S** bit on **PORTS** register; where n is **0, 1, 2, 3 or 4**. When P(n)S is set to 1, Ports are selected Schmitt trigger inputs on Port(n). The **P1.0** (XTAL2) can be configured as clock output when used on-chip RC or external Oscillator is clock source, and the frequency of clock output is divided by 4 on on-chip RC clock or external Oscillator.

P1.5 and **P1.6(/INT0)** that supported I2C are permanent open drain pins.

22.1 Quasi-Bidirectional Output Configuration

The default port output configuration for standard N79E875 series I/O ports is the quasi-bidirectional output that is common on the 80C51 and most of its derivatives. This output type can be used as both an input and output without the need to reconfigure the port. This is possible because when the port outputs a logic high, it is weakly driven, allowing an external device to pull the pin low. When the pin is pulled low, it is driven strongly and able to sink a fairly large current. These features are somewhat similar to an open drain output except that there are three pull-up transistors in the quasi-bidirectional output that serve different purposes. One of these pull-ups, called the “very weak” pull-up, is turned on whenever the port latch for the pin contains a logic 1. The very weak pull-up sources a very small current that will pull the pin high if it is left floating.

A second pull-up, called the “weak” pull-up, is turned on when the port latch for the pin contains a logic 1 and the pin itself is also at a logic 1 level. This pull-up provides the primary source current for a quasi-bidirectional pin that is outputting a 1. If a pin that has a logic 1 on it is pulled low by an external device, the weak pull-up turns off, and only the very weak pull-up remains on. In order to pull the pin low under these conditions, the external device has to sink enough current to overpower the weak pull-up and take the voltage on the port pin below its input threshold.

The third pull-up is referred to as the “strong” pull-up. This pull-up is used to speed up low-to-high transitions on a quasi-bidirectional port pin when the port latch changes from a logic 0 to a logic 1.

When this occurs, the strong pull-up turns on for a brief time, two CPU clocks, in order to pull the port pin high quickly. Then it turns off again. The quasi-bidirectional port configuration is shown as below.

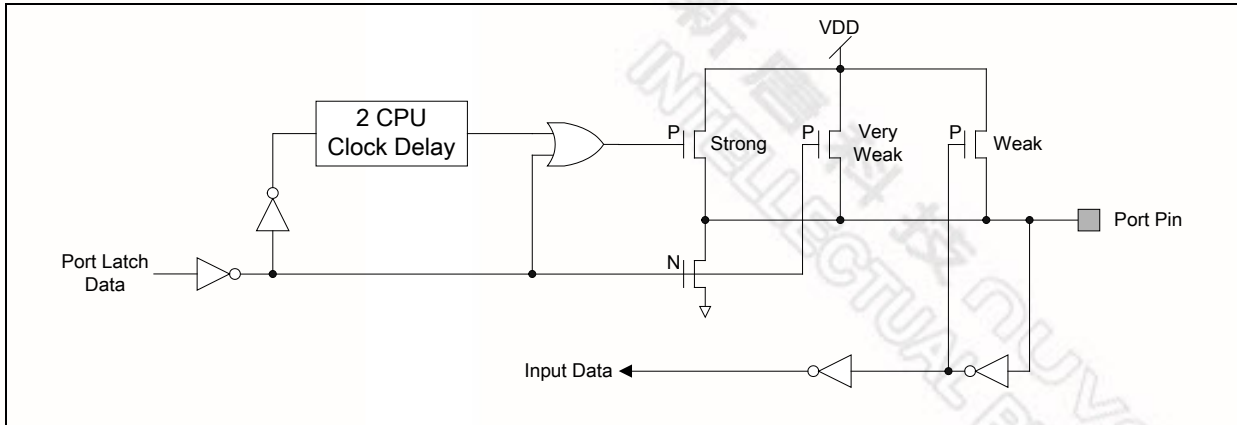

Figure 22-1: Quasi-Bidirectional Output

22.2 Open Drain Output Configuration

The open drain output configuration turns off all pull-ups and only drives the pull-down transistor of the port driver when the port latch contains a logic 0. To be used as a logic output, a port configured in this manner must have an external pull-up, typically a resistor tied to VDD. The pull-down for this mode is the same as for the quasi-bidirectional mode. The open drain port configuration is shown as below.

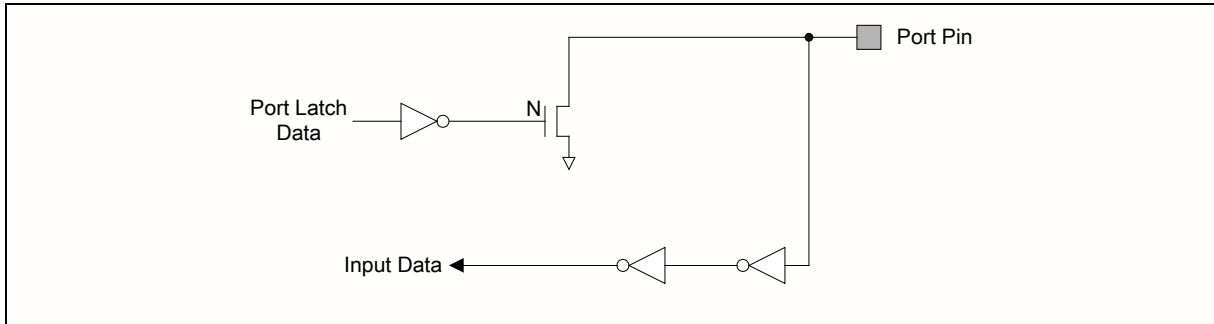

Figure 22-2: Open Drain Output

22.3 Push-Pull Output Configuration

The push-pull output configuration has the same pull-down structure as both the open drain and the quasi-bidirectional output modes, but provides a continuous strong pull-up when the port latch contains a logic 1. The push-pull mode may be used when more source current is needed from a port output. The push-pull port configuration is shown below. One port pin that cannot be configured is P1.4. P1.4 may be used as a Schmitt trigger input if the device has been configured for an internal reset and is not using the external reset input function /RST.

The value of port pins at reset is determined by the PRHI bit in the CONFIG0 register. Ports may be configured to reset high or low as needed for the application. When port pins are driven high at reset, they are in quasi-bidirectional mode and therefore do not source large amounts of current. Every output on the device may potentially be used as a **20mA** sink LED drive output. However, there is a maximum total output current for all ports which must not be exceeded.

All ports pins of the device have slew rate controlled outputs. This is to limit noise generated by quickly switching output signals. The slew rate is factory set to approximately 10 ns rise and fall times. The

PORTS SFR bits can enable Schmitt trigger inputs on each I/O port. The AUXR2 register has bits to enable toggle outputs from Timer 0 and Timer 1, and enable a clock output if either the internal RC oscillator or external clock input is being used. The last two functions are described in the Timer/Counters and Oscillator sections respectively. Each I/O port of this device may be selected to use TTL level inputs or Schmitt inputs with hysteresis. A single configuration bit determines this selection for the entire port. Port pin P1.4 always has a Schmitt trigger input.

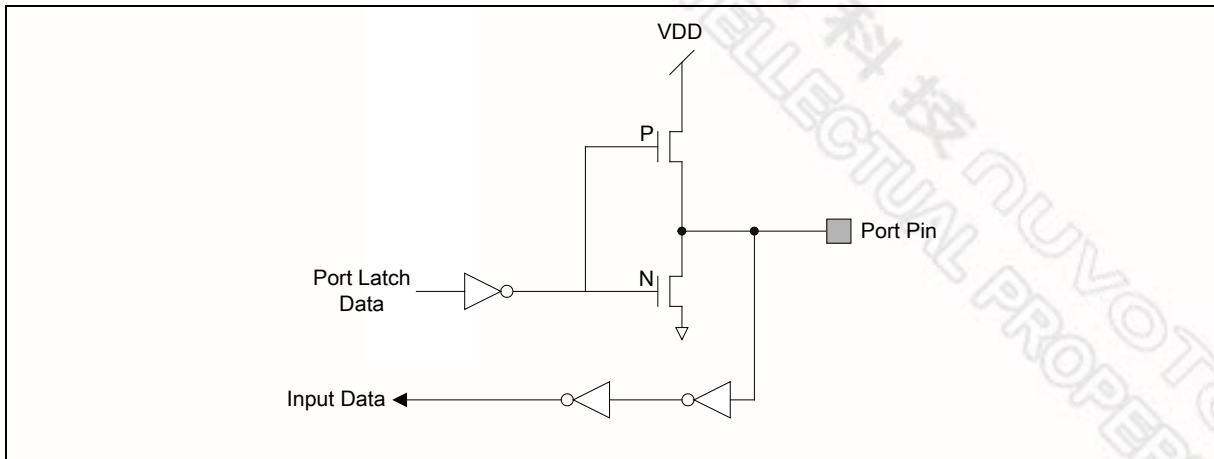

Figure 22-3: Push-Pull Output

22.4 Input Only Configuration

By configure this mode, the ports are only digital input and disable digital output. The N79E875 series can select input pin to Schmitt trigger or TTL level input by PxM1.y and PxM2.y registers.

22.5 SFR of I/O Port Configuration

SYMBOL	DEFINITION	ADDRESS	MSB								BIT ADDRESS, SYMBOL				LSB	RESET
P4M2	PORT 4 OUTPUT MODE 2	FBH	-	-	-	-	-	-	-	-	P4M2.3	P4M2.2	P4M2.1	P4M2.0	XXXX 0000b	
P4M1	PORT 4 OUTPUT MODE 1	FAH	-	-	-	-	-	-	-	-	P4M1.3	P4M1.2	P4M1.1	P4M1.0	XXXX 0000b	
PORTS	PORT SHMITT REGISTER	ECH	-	-	-	-	-	-	-	-	P4S	P3S	P2S	P1S	P0S	XXX0 0000B
P2M2	PORT 2 OUTPUT MODE 2	B6H	P2M2.7	P2M2.6	P2M2.5	P2M2.4	P2M2.3	P2M2.2	P2M2.1	P2M2.0	0000 0000b					
P2M1	PORT 2 OUTPUT MODE 1	B5H	P2M1.7	P2M1.6	P2M1.5	P2M1.4	P2M1.3	P2M1.2	P2M1.1	P2M1.0	0000 0000b					
P1M2	PORT 1 OUTPUT MODE 2	B4H	P1M2.7	-	-	-	-	-	-	-	000X 0000b	P1M2.3	P1M2.2	P1M2.1	P1M2.0	
P1M1	PORT 1 OUTPUT MODE 1	B3H	P1M1.7	-	-	-	-	-	-	-	000X 0000b	P1M1.3	P1M1.2	P1M1.1	P1M1.0	
P0M2	PORT 0 OUTPUT MODE 2	B2H	P0M2.7	P0M2.6	P0M2.5	P0M2.4	P0M2.3	P0M2.2	P0M2.1	P0M2.0	0000 0000b					
P0M1	PORT 0 OUTPUT MODE 1	B1H	P0M1.7	P0M1.6	P0M1.5	P0M1.4	P0M1.3	P0M1.2	P0M1.1	P0M1.0	0000 0000b					
P3M1	PORT 3 OUTPUT MODE 1	9EH	P3M1.7	P3M1.6	P3M1.5	P3M1.4	P3M1.3	P3M1.2	P3M1.1	P3M1.0	0000 0000b					

23 OSCILLATOR

N79E875 series provide three oscillator input options. These are configured at CONFIG register (CONFIG0) that include On-Chip RC Oscillator Option, External Clock Input Option and Crystal Oscillator Input Option. The Crystal Oscillator Input frequency may be supported from 4MHz to 40MHz, and optionally with capacitor or resistor.

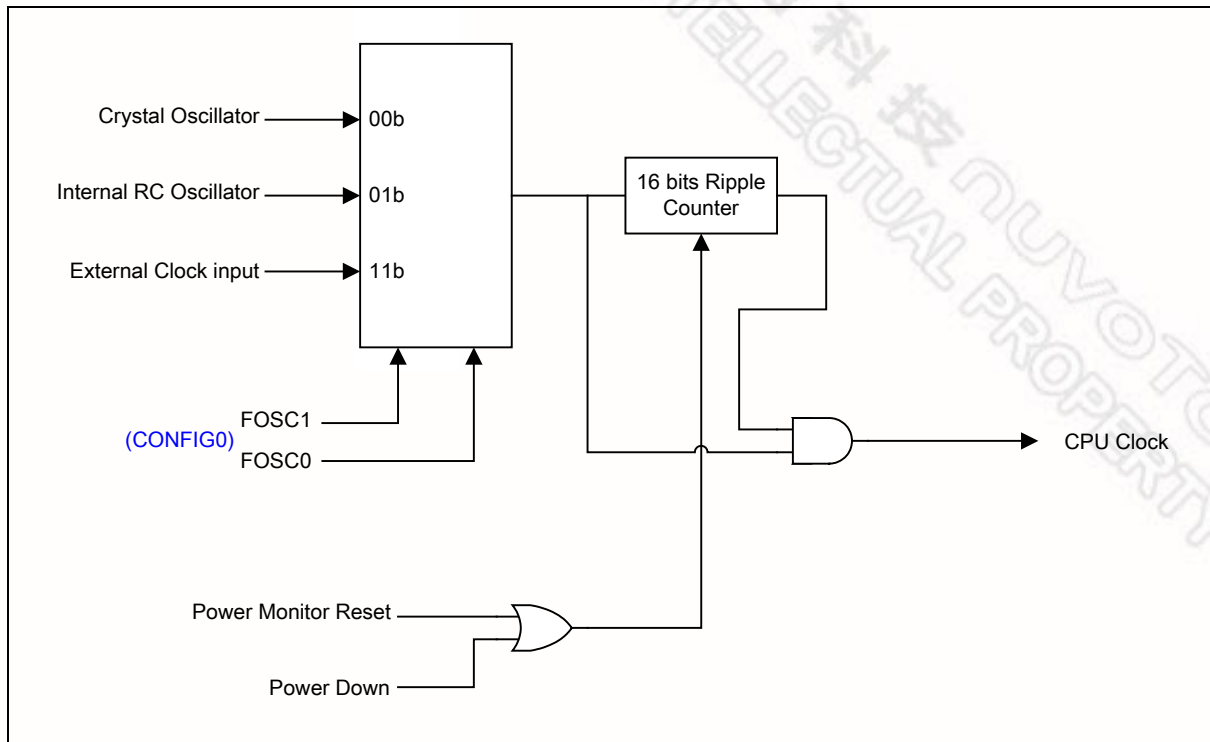

Figure 23-1: Oscillator

23.1 On-Chip RC Oscillator Option

The On-Chip RC Oscillator is programmable to [22.1184MHz/11.0592MHz +/- 2%](#) (selectable by FS1 config bit) frequency to support clock source. When FOSC1, FOSC0 = 01b, the On-Chip RC Oscillator is enabled. A clock output on P1.0 (XTAL2) may be enabled when On-Chip RC oscillator is used.

23.2 External Clock Input Option

The clock source pin (XTAL1) is from External Clock Input by FOSC1, FOSC0 = 11b, and frequency range is form 0Hz up to 40MHz. A clock output on P1.0 (XTAL2) may be enabled when External Clock Input is used.

N79E875 series support a clock output function when either the on-chip RC oscillator or the external clock input options is selected. This allows external devices to synchronize to the device. When enabled, via the ENCLK bit in the AUXR2 register, the clock output appears on the XTAL2/CLKOUT pin whenever the on-chip oscillator is running, including in Idle Mode. The frequency of the [clock output is 1/4 of the CPU clock rate](#). If the clock output is not needed in Idle Mode, it may be turned off prior to entering Idle mode, saving additional power. The clock output may also be enabled when the external clock input option is selected.

24 POWER MONITORING FUNCTION

Power-On Detect and Brownout are two additional power monitoring functions implemented in N79E875 series to prevent incorrect operation during power up and power drop or loss.

24.1 Power On Detect

The Power-On Detect function is a design to detect power up after power voltage reaches to a level where Brownout Detect can work. After power on detect, the POR (PCON.4) will be set to "1" to indicate an initial power up condition. The POR flag will be cleared by software.

24.2 Brownout Detect

The N79E875 has an on-chip Brown-out Detection (BOD) circuit for monitoring the V_{DD} level during operation by comparing it to a fixed trigger level. There are 3 trigger levels of BOD selected by 2 config0 bits BOV[1:0] suited for wide voltage use. The following table shows the brownout voltage levels supported;

BOV bits (CONFIG0.4-3)	Brownout voltage detect level
00	4.5V
01	3.8V
1x	2.6V (default)

Table 24-1: Brownout Voltage Detect Levels

When the Brownout voltage is drop to the select level, the brownout detector will detect and keeps this active until V_{DD} is returns to above brownout Detect voltage. The Brownout Detect block is as follow.

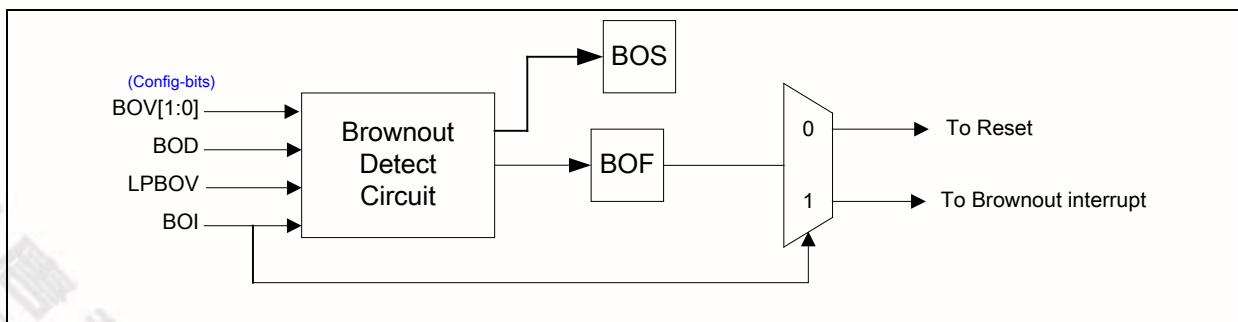

Figure 24-1: Brownout Detect Block

When Brownout Detect is enabled by BOD (AUXR1.6), the BOF (PCON.5) flag will be set that it causes brownout reset or interrupt, and BOF will be cleared by software. If BOI (AUXR1.5) is set to "1", the brownout detect will cause interrupt via the EA (IE.7) and EBO (IE.5) bits is set.

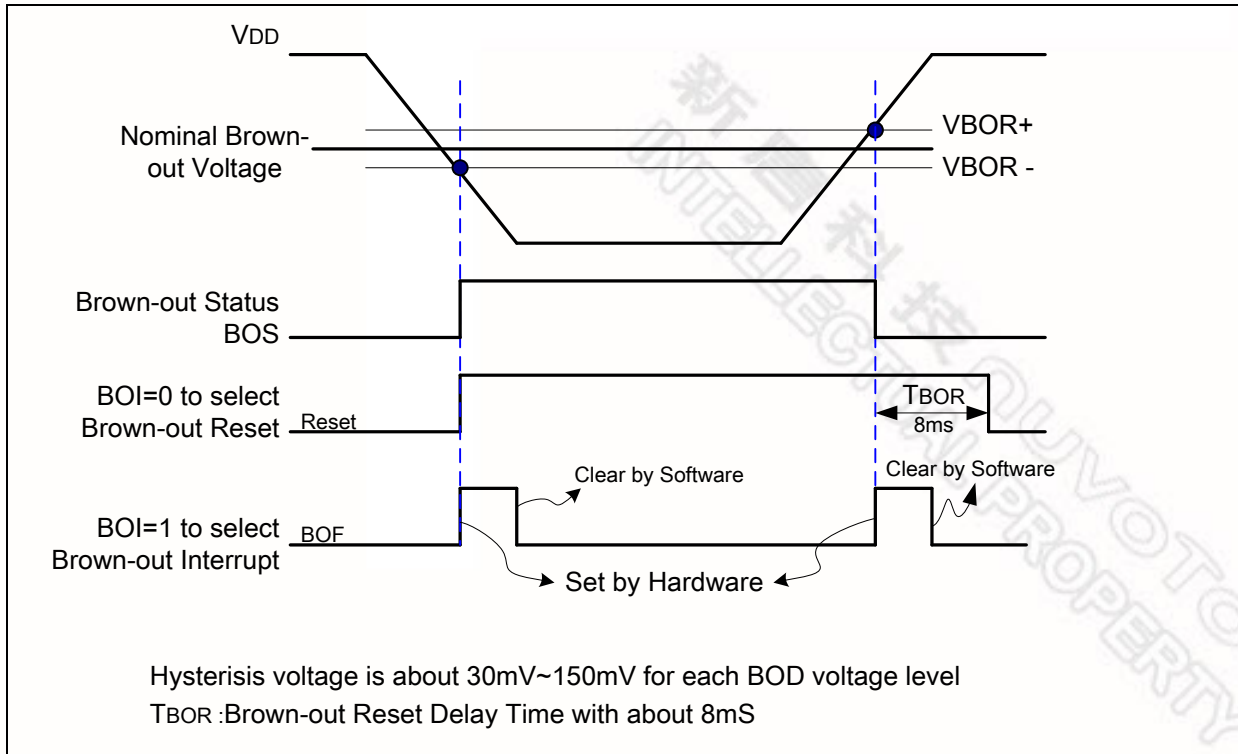

Figure 24-2: Brown-out Voltage Detection

24.3 SFR of Brown-out Detection

SYMBOL	DEFINITION	ADDRESS	MSB	BIT ADDRESS, SYMBOL							LSB	RESET
AUXR1	AUX FUNCTION REGISTER 1	A2H	KBF	BOD	BOI	LPBOD	SRST	ADCEN	RCCLK	BOS	0X00 0000B	
PCON	POWER CONTROL	87H	SMOD	SMOD0	BOF	POR	GF1	GF0	PD	IDL	00XX 0000B	

25 PULSE-WIDTH-MODULATED (PWM) OUTPUTS

In SA8218, the build-in PWM function is specially designed for driving motor control applications. Using the PWM and timer2/input capture module with proper control flow by software can drive 3-phase Brushless DC motor, 3-phase AC induction motor and DC motor.

25.1 PWM Features

The PWM block supports the features as below;

- Four independent 12-bit PWM duty control units with maximum 8 port pins:
 - 4 independent PWM output: PWM0, PWM2, PWM4 and PWM6
 - 3 complementary PWM pairs, with each pin in a pair mutually complement to each other and capable of programmable dead-time insertion: (PWM0,PWM1), (PWM2,PWM3) and (PWM4,PWM5)
 - 3 synchronous PWM pairs, with each pin in a pair in-phase: (PWM0,PWM1), (PWM2,PWM3) and (PWM4,PWM5)
- Group control bit: PWM2 and PWM4 are synchronized with PWM0
- Support Edge aligned mode and Center aligned mode.
- Programmable dead-time insertion between complementary paired PWMs.
- Each pin of from PWM0 to PWM5 has independent polarity setting control.
- Mask output control for Electrically Commutated Motor operation.
- Tri-state output at reset.
- Hardware brake protections.
- Support 2 independent interrupts.
 - Interrupt is synchronously requested at PWM frequency when up/down counter comparison matched (edge aligned mode) or underflow (center aligned mode).
 - Interrupt is requested when external brake pins asserted
- The PWM signals before polarity control stage are defined in the view of positive logic. The PWM ports is active high or active low are controlled by polarity control register.
- High Source/Sink current.

After CPU reset the internal output of the each PWM channels depends on the polarity setting. The interval between successive outputs is controlled by a 12-bit up/down counter which uses the oscillator frequency with configurable internal clock pre-scalar as its input. The PWM counter clock has the frequency as the clock source $F_{PWM} = F_{CPU}/\text{Pre-scalar}$. The Figure 25-1 is the block diagram for PWM.

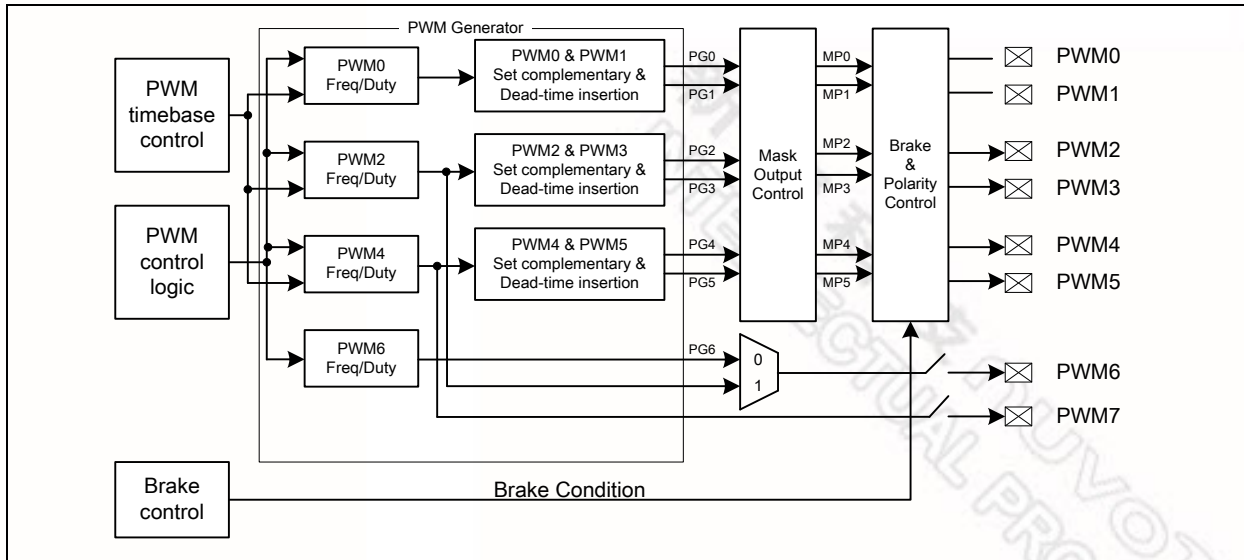

Figure 25-1: PWM Block Diagram

新唐科技 NUVOTON
INTELLECTUAL PROPERTY

25.2 PWM Operation

The following diagram shows PWM time-base generator.

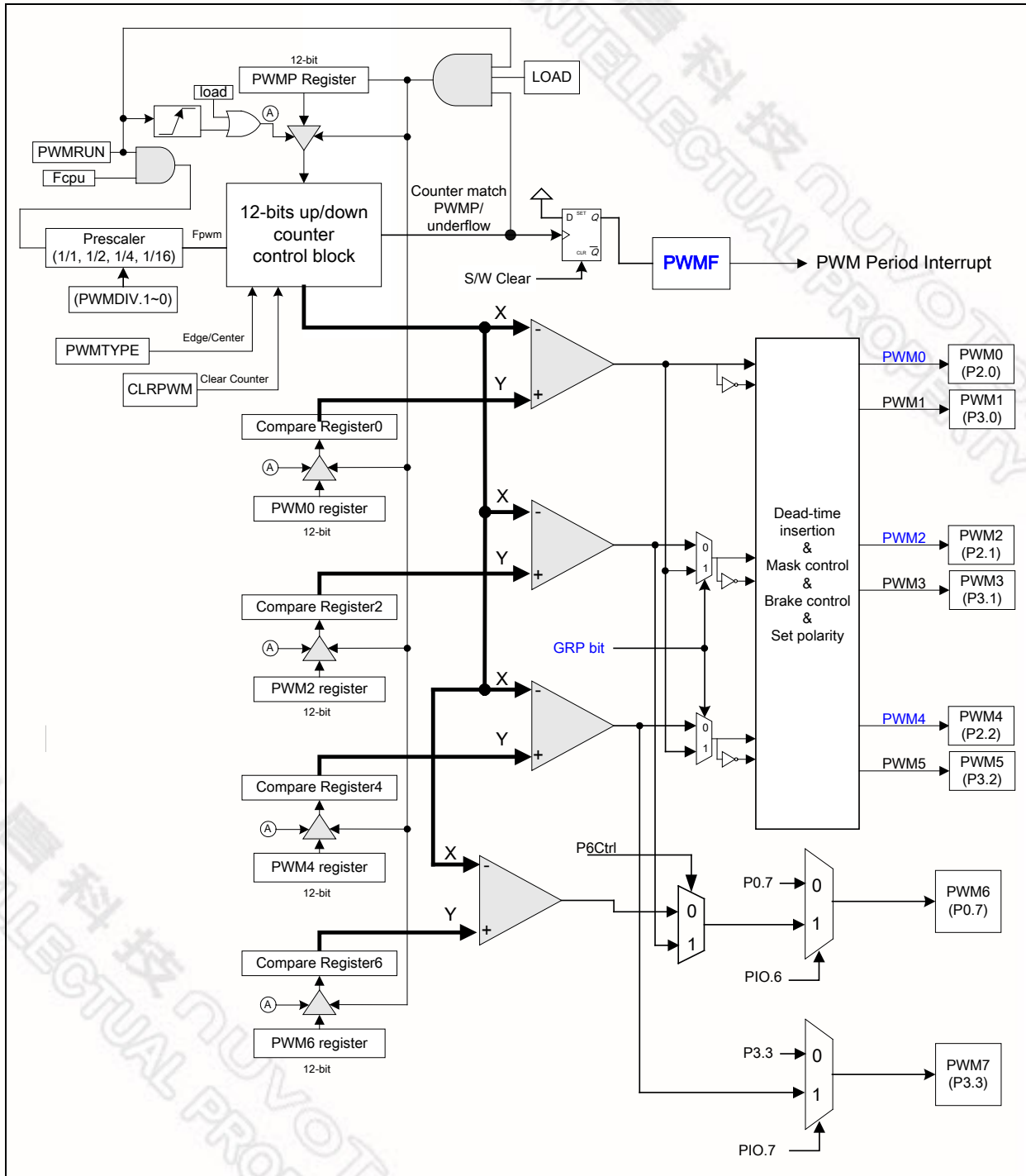

Figure 25-2: PWM Time-base Generator

The overall functioning of the PWM module is controlled by the contents of the PWMCON1, PWMB and PWMCON3 registers. The operation of most of the control bits is straightforward. PWMCON1.7 (PWMRUN) allows the PWM to be either in the run or idle state. The transfer of the data from the PWMP register to 12-bit counter will occur on the rising edge of PWMCON1.7 (PWMRUN) or during PWMRUN with PWMCON1.6 (load) and counter match/underflow occur. The transfer of the data from the PWMn registers to the compare registers is controlled by the PWMCON1.6 (load) (with condition that PWMRUN=1 and match/underflow occurs).

Notes:

- A compare value greater than the counter reloaded value resulted in the PWM output being permanently high. In addition there are two special cases. If compare register is set to 000H, the PWMn output will stay at low, and if compare register is set to FFFH, the PWMn output will stuck at high until there is a change in the compare register. [n = 0-3].
- During ICP mode, PWM pins will be tri-stated. PWM operation will be stop. When exit from ICP mode, the PWM pins will follow the last SFR port values.

The PWMP register fact that writes are not into the Counter register that controls the counter; rather they are into a holding register. The transfer of data from this holding register, into the register which contains the actual reload value, occurs when the following conditions are met; Load = 1, PWMRUN = 1 and PWM match/underflow. The width of each PWM output pulse is determined by the value in the appropriate compare register. Each PWM register pair of (**PWMPH,PWMP L**), (**PWM0H,PWM0L**), (**PWM2H,PWM2L**), (**PWM4H,PWM4L**) and (**PWM6H, PWM6L**), in the format of 12-bit width by combining 4 LSB of high byte register and 8 bits of low byte register, decides the PWM period and each channel's duty cycle.

Please take note that duty registers PWM0~6 and period registers PWMP are double-buffered registers used to set the duty cycle and counting period for the PWM time base respectively. For the 1st buffer it is accessible by user while the 2nd buffer holds the actual compare value used in the present period. Load bit must be set to 1 to enable the value to be loaded in to the 2nd buffer register when counter underflow/match.

25.2.1 PWM Operation Mode

This device supports 2 operation modes: Edge-aligned and Centre-aligned mode.

The following equations show the formula for period and duty for each pwm operation mode:

Edge aligned:

$$\text{Period} = (\text{PWMP} + 1) * \text{CPU clock period/pre-scalar}$$

$$\text{Duty} = \text{duty} * \text{CPU clock period /pre-scalar}$$

Centre aligned:

$$\text{Period} = (\text{PWMP} * 2) * \text{CPU clock period/pre-scalar}$$

$$\text{Duty} = (\text{duty} * 2 - 1) * \text{CPU clock period/pre-scalar}$$

Note: "duty" refers to PWM0/2/4/6 register value.

25.2.2 Edge aligned PWM (up-counter)

In Edge-aligned PWM Output mode, the 12 bits counter will starts counting from 0 to match with the value of the duty cycle PWM0 (old), when this happen it will toggle the PWM0 generator output to low. The counter will continue counting to match with the value of the period register PWMP (old), at this moment, it toggles the PWM0 generator output to high and new PWM0 (new) and PWMP(new) are updated with Load=1 and request the PWM interrupt if PWM interrupt is enabled(EIE1.6=1).

Figure 25-3, Figure 25-4 and Figure 25-5 depict the Edge-aligned PWM timing and operation flow.

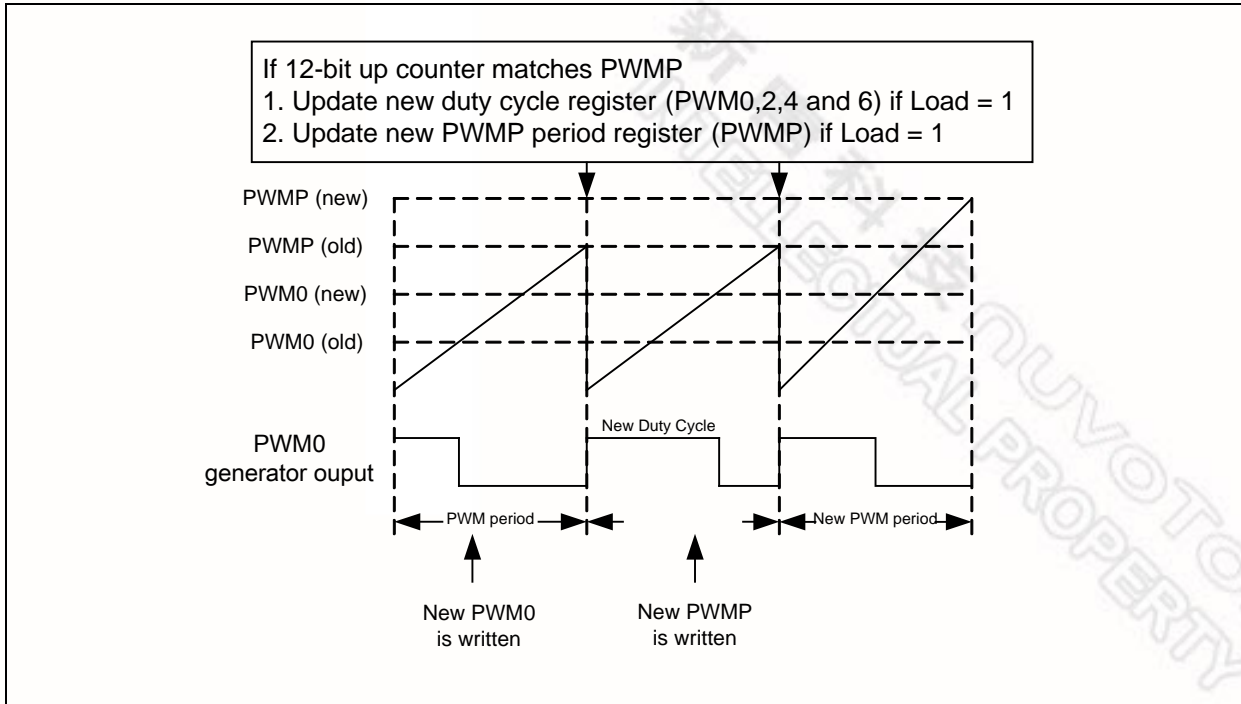

Figure 25-3: Edge-Aligned PWM

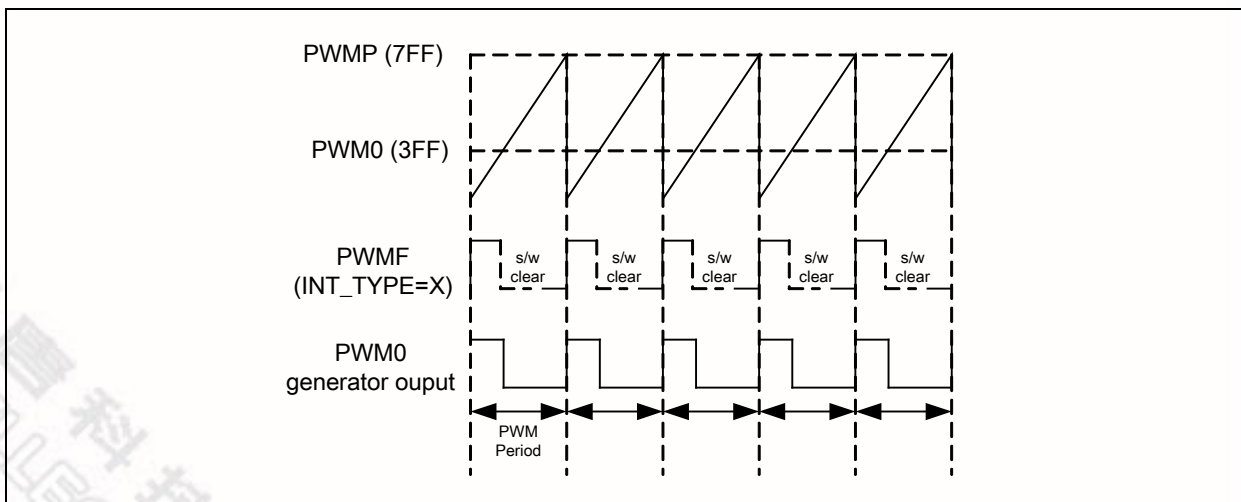

Figure 25-4: PWM0 Edge Aligned Waveform Output

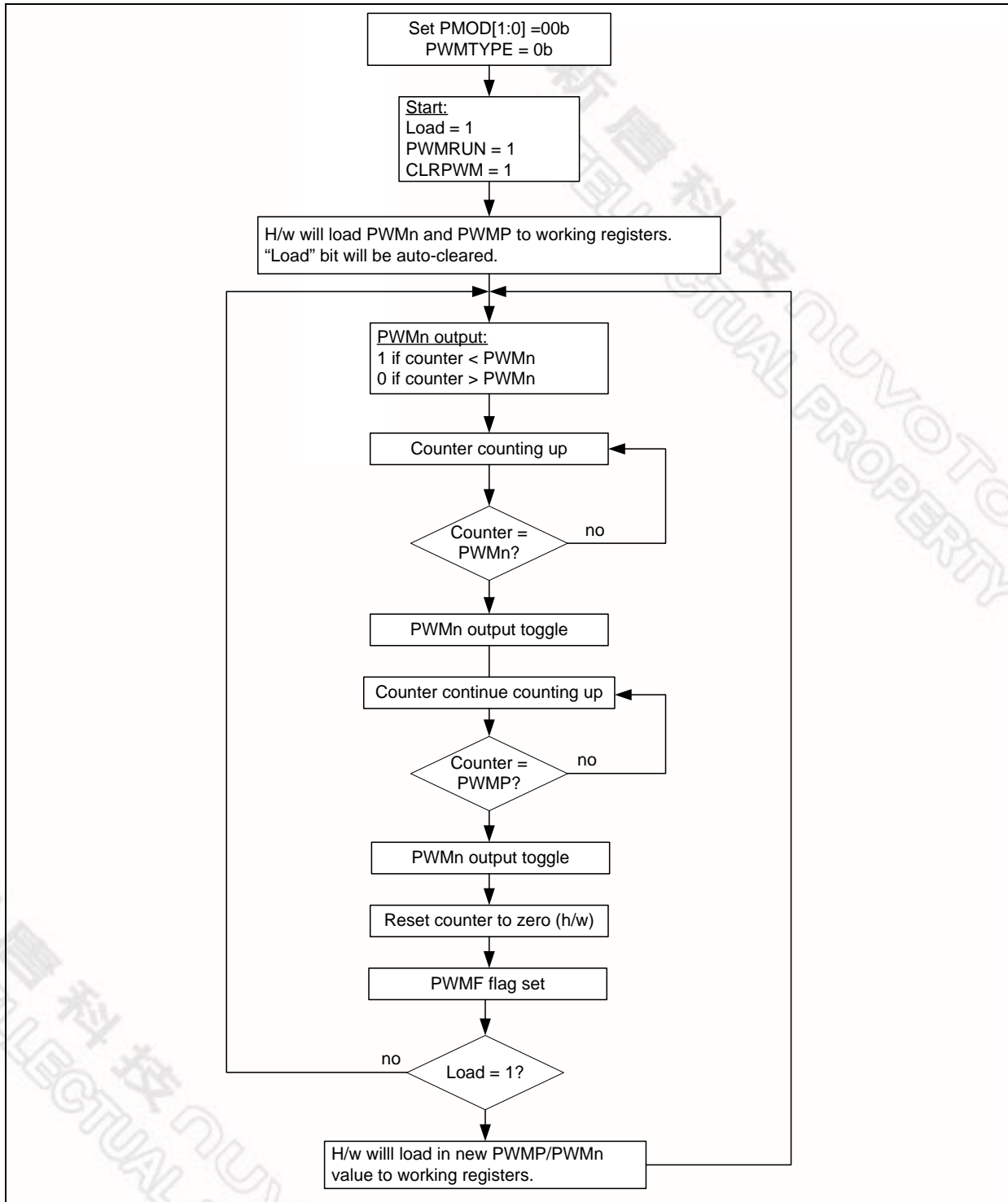

Figure 25-5: Edge-Aligned Flow Diagram

25.2.3 Center Aligned PWM (up/down counter)

The Center-aligned PWM signals are produced by the module when the PWM time base is configured in an Up/Down Counting mode. The counter will start counting-up from 0 to match the value of PWM0 (old), this will cause the toggling of the PWM0 generator output to low. The counter will continue counting to match with the PWMP (old). Upon reaching this states counter is configured automatically to down counting, when counter matches the PWM0 (old) value again the PWM0 generator output toggles to high. Once the counter underflows it will update the PWM period register PWMP(new) and duty cycle register PWM0(new) with Load = 1.

In Center-aligned mode, the PWM interrupt is requested at down-counter underflow if INT_TYPE (PWMCON3.0)=0 or at up-counter matching with PWMP if INT_TYPE(PWMCON3.0)=1.

Figure 25-6, Figure 25-7 and Figure 25-8 depict the Center-aligned PWM timing and operation flow.

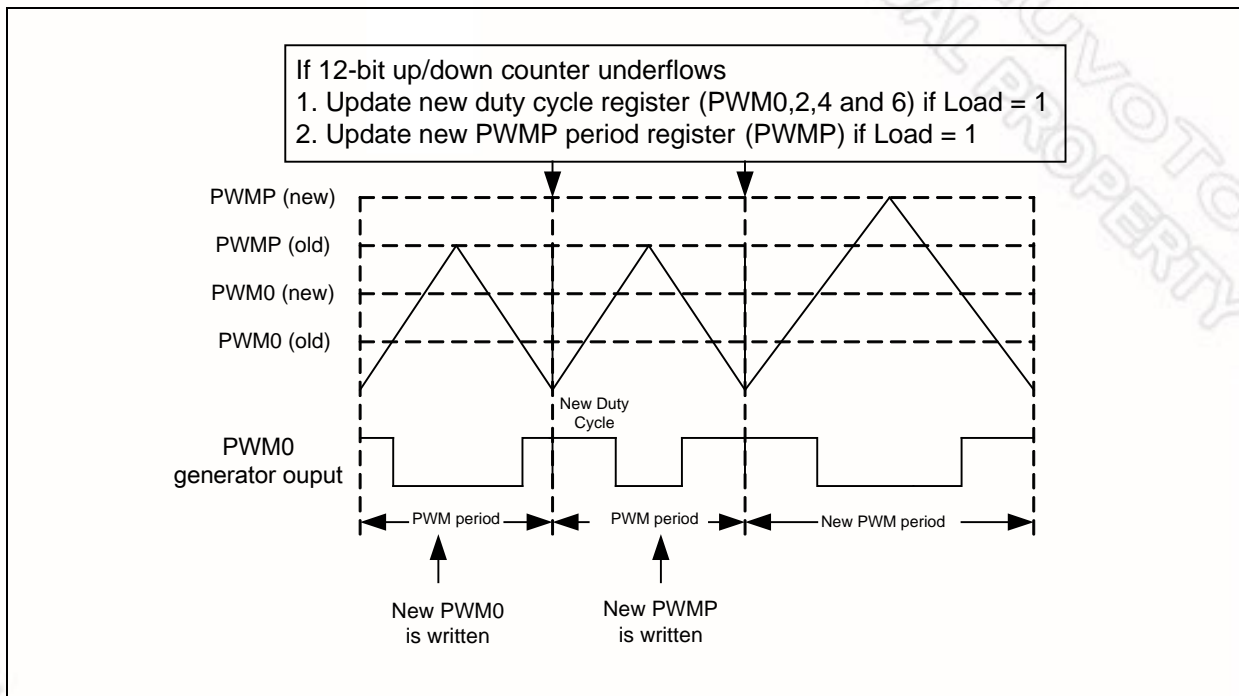

Figure 25-6: Center-Aligned Mode

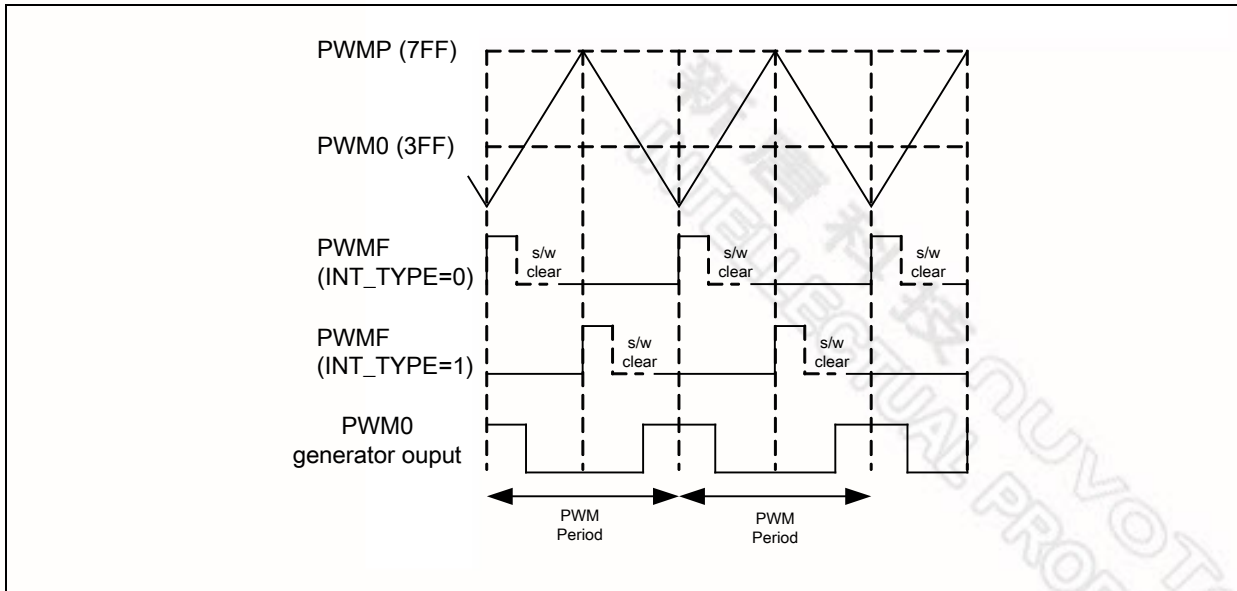

Figure 25-7: PWM0 Center Aligned Waveform Output

新唐科技 NUVOTON
INTELLECTUAL PROPERTY

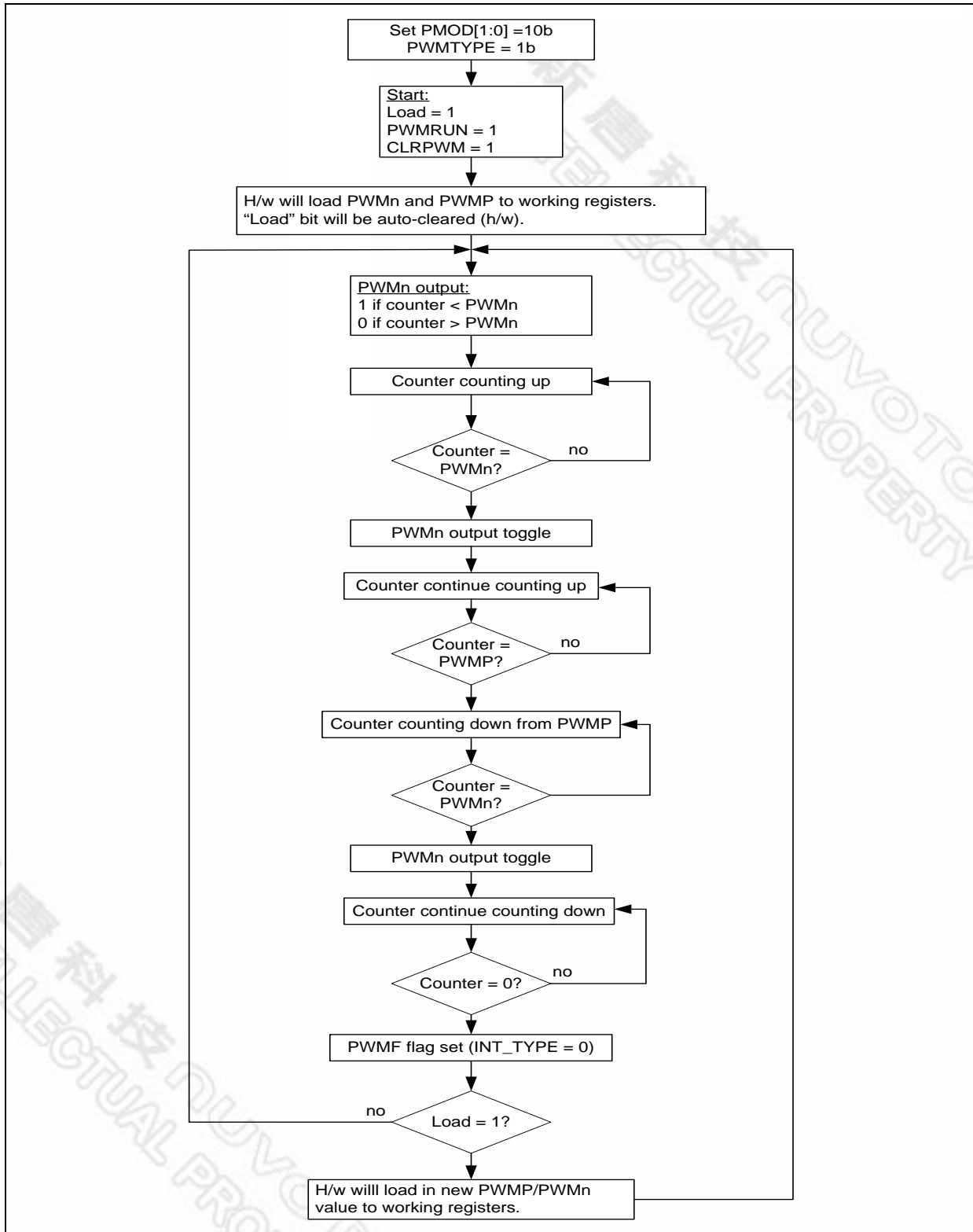

Figure 25-8: Center-aligned Flow Diagram (INT_TYPE = 0)

25.3 PWM Brake Function

This device supported 2 external brake pins; BKP0 and BKP1 pins. Both brake pins have each a 4-degree digital filter that is user controllable through BK_nFILT.1-0 bits (n=0,1). The Brake function is controlled by the contents of the SFR PWMCON1-4 registers.

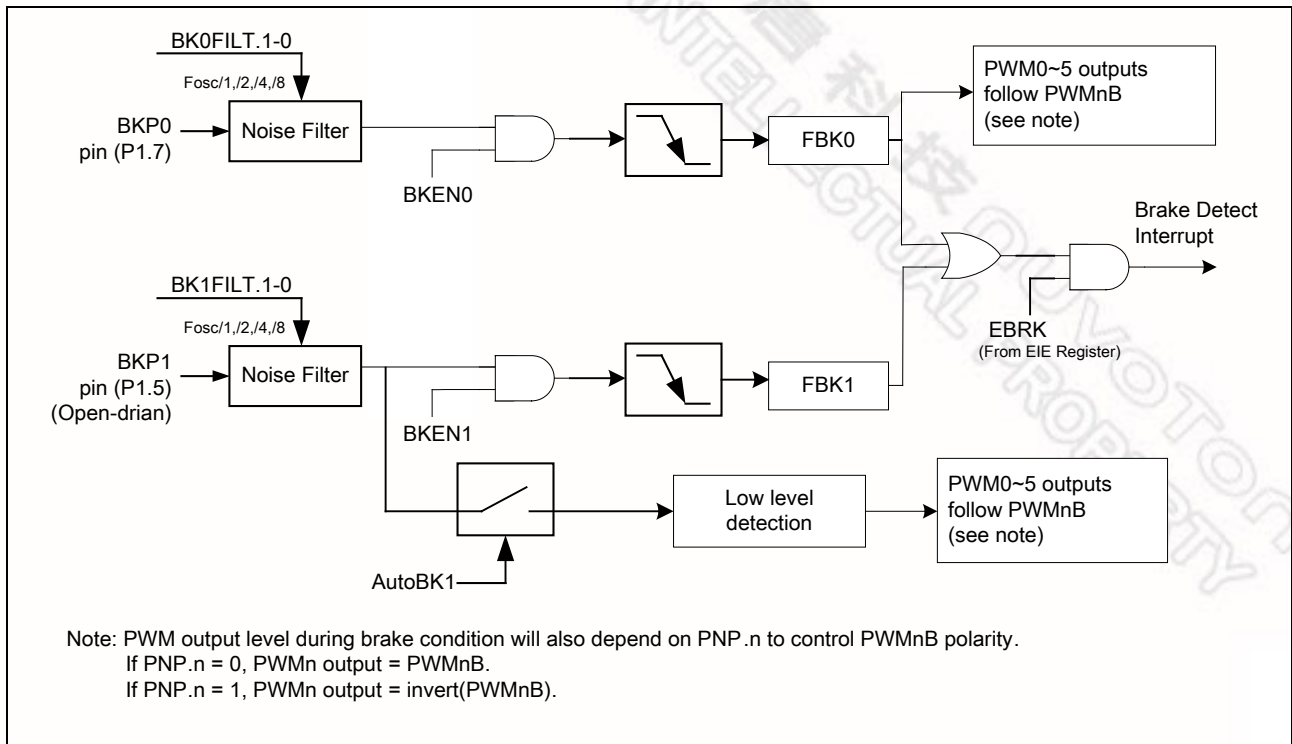

Figure 25-9: PWM Brake Function

The following table summaries the effect of each brake pins; the Figure 25-10 and Figure 25-11 illustrate the brake signals vs PWM operation.

Brake Pin	Brake trigger condition	Actions
BKP0	A falling edge at BKP0	<ol style="list-style-type: none"> 1. FBK0 flag set by H/W; but cleared by S/W. 2. PWM0~5 outputs follow PWMnB bits. PNP bits are also able to control the polarity of PWMnB. If PNP.n=0, PWMn pin output = PWMnB. If PNP.n=1, PWMn pin output = invert(PWMnB). 3. H/W sets PWMRUN=0 to stop PWM generator. 4. PWM0~5 pin outputs does not resume on release of BKP0 pin. PWM0~5 will remain in PWMnB state after the s/w clearing of FBK0 flag, if user keep PWMRUN = 0. If user re-enabled PWMRUN, the brake state will be release on next PWM cycle/period.
BKP1	A falling edge at BKP1; Low level state	<ol style="list-style-type: none"> 1. FBK1 flag set by the falling edge at BKP1; but cleared by S/W. 2. If AUTOBK1=1 and BKP1 detected as low level,

		<p>PWM0~5 pin outputs follow PWMnB bits. Otherwise, PWM0~5 will continue follow PWM generators' output. In both situations, PNP bits are also able to control port polarity.</p> <ol style="list-style-type: none"> 3. PWMRUN bit remain asserted to keep PWM generators running. 4. PWM0~5 resume if BKP1 pin state returns to high state. PWM0~5 will resume on start of next PWM cycle/period.
--	--	---

Note that user require to enable brake enable bits, BKENn, in order for the above to be effective.

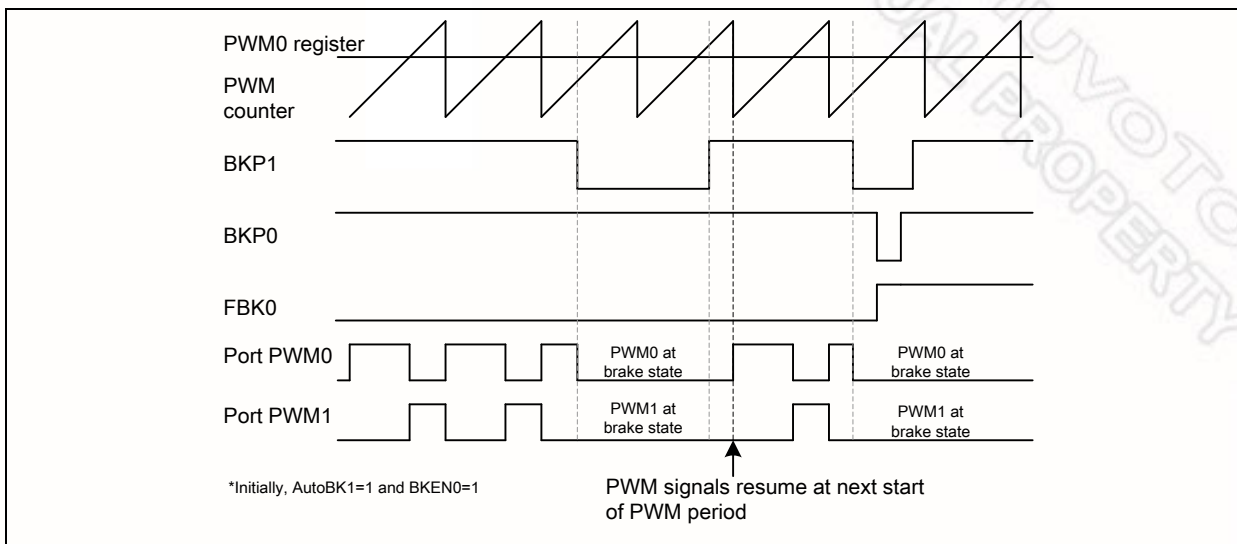

Figure 25-10: PWM brake condition (edge aligned mode)

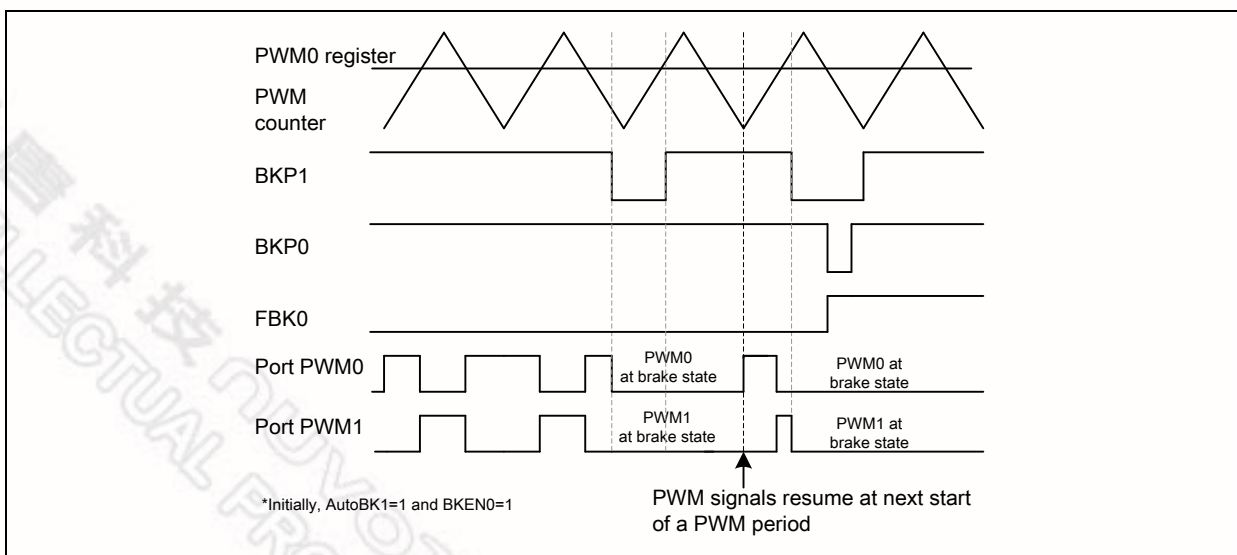

Figure 25-11: PWM brake condition (centre aligned mode)

Since the both brake conditions being asserted will automatically cause FBKn flag will be set, the user

program can poll these brake flag bits or enable PWM's brake interrupt to determine which condition causes a brake to occur.

25.4 PWM Output Driving Control

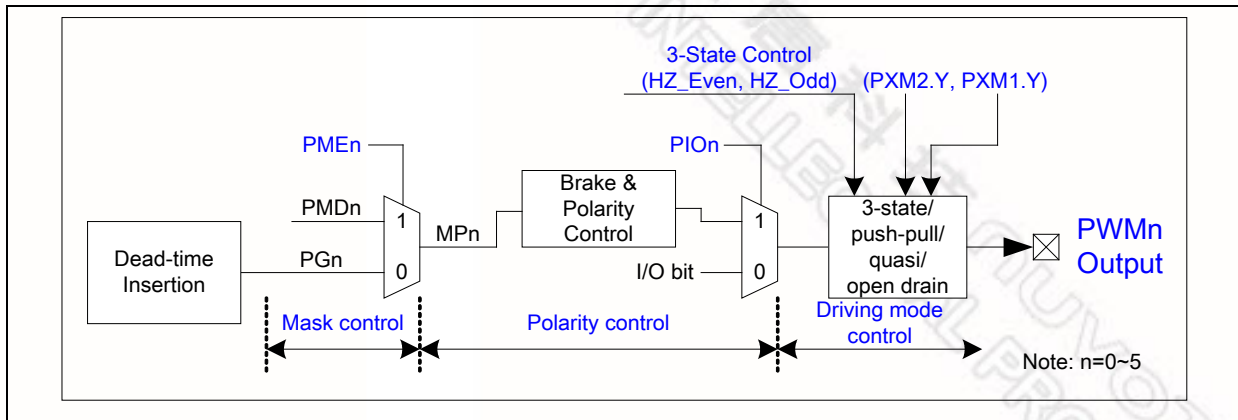

Figure 25-12: PWM Output Driving Control

The driving type of PWM output ports can be initialized as Tri-state type or other type dependent with SFR PxMy setting after any reset. As show in the above diagram, PWM output structures are controllable through option bits (config1.0-1), SFR (PWMCON3.HZ_Even,HZ_Odd) bits and SFR PxMy mode registers.

HZ_Even/HZ_Odd (SFR PWMCON3 BITS)	PWM Output Drive mode
0	Depend on PxMy SFR.
1	Driving mode = Hi-Z.

Note: SFR bits for HZ_Even and HZ_Odd are latched from config1.0 and config1.1, respectively, during all reset.

25.5 PWM modes

This powerful PWM unit supports Independent mode which may be applied to DC and BLDC motor system, Complementary mode with dead-time insertion which may be used in the application of AC induction motor and synchronous motor, Synchronous mode that makes both pins of each pair are in phase. Besides, the Group mode, forces the PWM0, PWM2 and PWM4 synchronous with PWM0 generator, may simplify updating duty control in DC and BLDC motor applications.

25.5.1 Independent mode

Independent mode is enabled when PMOD.1-0 = 00b.

On default, the PWM is operating in independent mode, with four PWM even channels outputs: PWM0, PWM2, PWM4 and PWM6. Each channel is running off its own duty-cycle generator module.

PWM6 can be user controllable to output from PWM2 generator if P6CTRL = 1.

PWM7 is taking output from PWM4 generator.

25.5.2 Complementary mode

Complementary mode is enabled when $PMOD.1-0 = 01b$.

In this module there are three duty-cycle generators utilized for complementary mode, with total of three PWM output pair pins in this module. The total six PWM outputs are grouped into output pairs of even and odd numbered outputs. In complimentary modes, the internal odd PWM signal PGx , refer to Figure 25-1, must always be the complement of the corresponding even PWM signal. For example, $PG1$ will be the complement of $PG0$. $PG3$ will be the complement of $PG2$ and $PG5$ will be the complement of $PG4$. The time base for the PWM module is provided by its own 12-bit timer, which also incorporates selectable pre-scaler options.

25.5.2.1 Dead-Time Insertion

The dead time generator inserts an “off” period called “dead time” between the turnings off of one pin to the turning on of the complementary pin of the paired pins. This is to prevent damage to the power switching devices that will be connected to the PWM output pins. The complementary output pair mode has an 8-bit counter used to produce the dead time insertion. The complementary outputs are delayed until the timer counts down to zero.

The dead-time can be calculated from the following formula:

$$\text{Dead-time} = F_{\text{CPU}} * (\text{DTCNT}.[7:0]+1).$$

The timing diagram below indicates the dead time insertion for one pair of PWM signals.

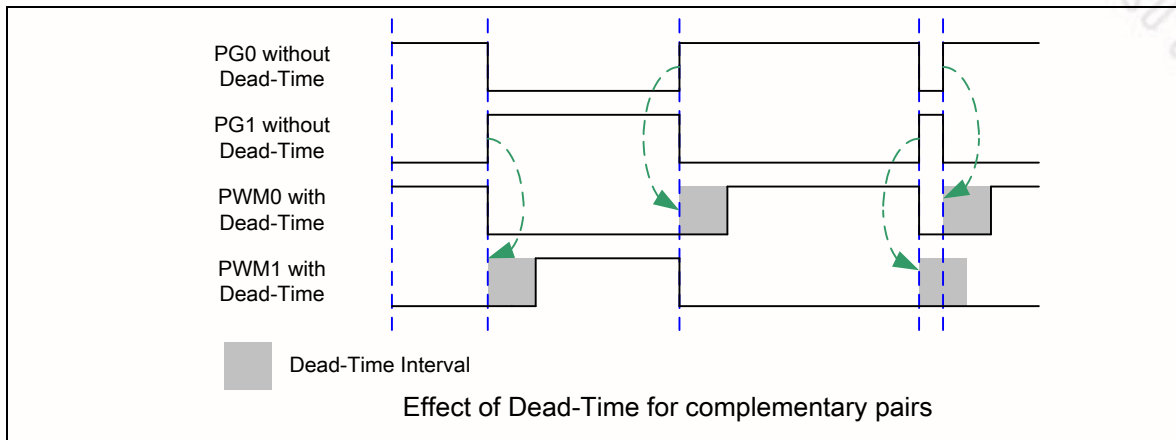

Figure 25-13: Dead-Time Insertion

$PDTC0$ and $DTCNT$ have time access protection in writing access. In Power inverter application, a dead time insertion avoids the upper and lower switches of the half bridge from being active at the same time. Hence the dead time control is crucial to proper operation of a system. Some amount of time must be provided between turning off of one PWM output in a complementary pair and turning on the other transistor as the power output devices cannot switch instantaneously.

25.5.3 Synchronous mode

Synchronous mode is enabled when $PMOD.1-0 = 10b$.

In the synchronization mode the PWM pair signals from PWM Generator are in-phase.

$PG1=PG0$, $PG3=PG2$ and $PG5=PG4$.

25.5.4 Group mode

Group mode is enabled when $PMOD.1-0 = 11b$.

This device support Group Mode control. This control allows all even PWM channels output to be duty controllable by PWM0 duty register.

If GRP = 1, both (PG2, PG3) and (PG4, PG5) pairs will follow (PG0, PG1), which imply;

PG4 = PG2 = PG0;

PG5 = PG3 = PG1 = invert (PG0) if Complementary mode is enabled (PMOD.1-0=01b)

25.6 Polarity Control

Each PWM port of from PWM0 to PWM5 has independent polarity control to configure the polarity of active state of PWM output. At default, the PWM output is active high. This implies the PWM OFF state is low and ON state is high. This is controllable through SFR PNP on each individual PWM channel.

The following diagram show the initial state before PWM starts with different polarity settings.

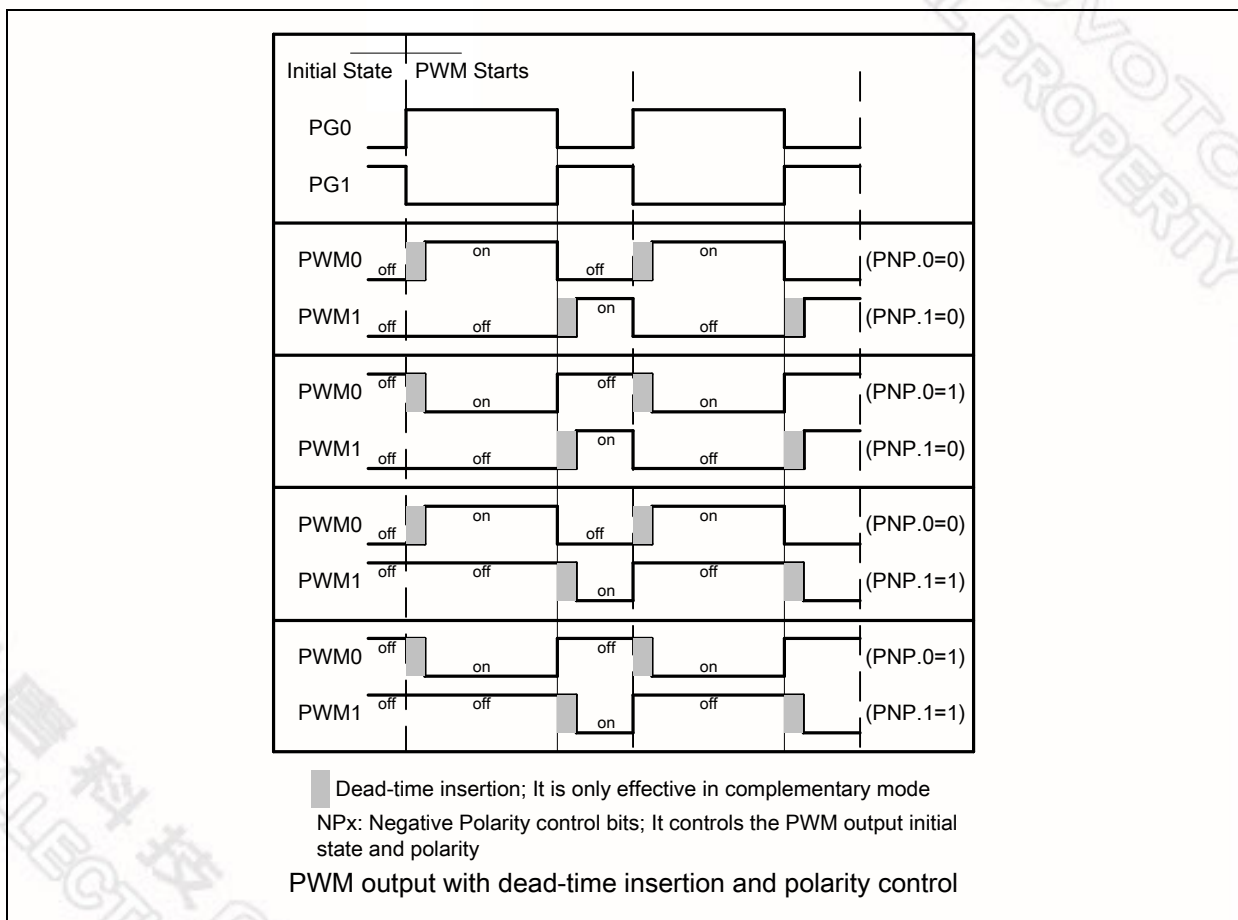

Figure 25-14: Initial state and polarity control with rising edge dead time insertion

25.7 PWM Mask Output

Each of the PWM output channels can be manually overridden by using the appropriate bits in the SFR PME and PMD registers to drive the PWM I/O pins to specified logic states independent of the duty cycle comparison units. The PWM mask bits are useful when controlling various types of Electrically Commutated Motor (ECM) like a BLDC motor. The PMD register contains six bits, PMD[5:0] determine which PWM I/O pins will be overridden. On reset PMD is 00H.

The PME register contains six bits, PME[5:0] determine the state of the PWM I/O pins when a particular output is masked via the PMD bits. On reset PME is 00H. The PME[5:0] bits are active-high. When the PME[5:0] bits are set, the corresponding PMD[5:0] bit will have effect on the PWM channel. When one of the PME bits is sets, the output on the corresponding PWM I/O pin will be determined by the state of the PMD bit and polarity control bit.

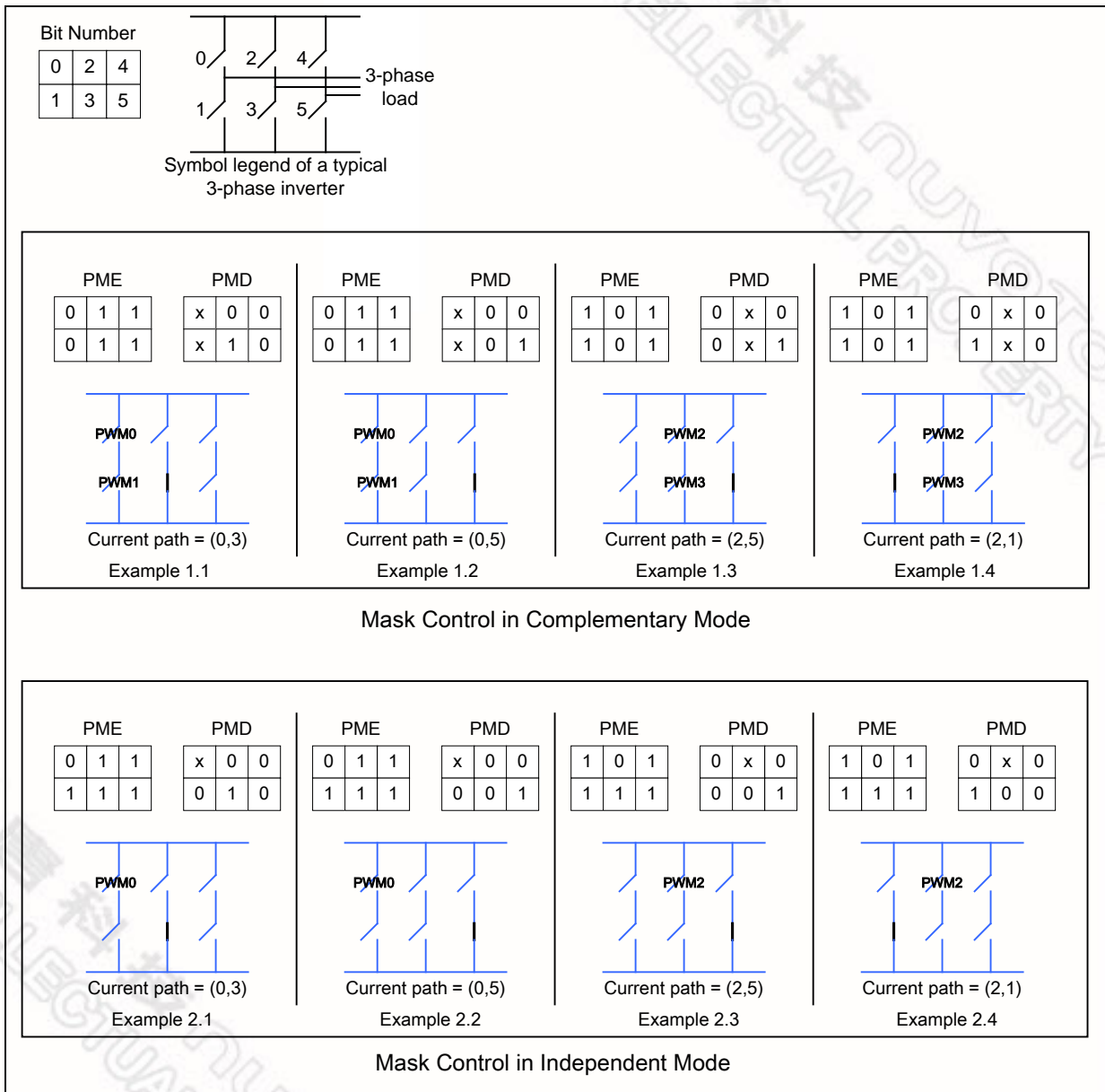

Figure 25-15 Illustration of Mask Control

Figure above shows example of how PWM mask control can be used for the override feature.

In example 1.1; PME[5:0] = 11 1100b, PMD[5:0] = 0010xxb (complementary mode)

- PWM channels 2-5 are masked from pwm frequency/duty generators.
 - PWM channels 2-5 outputs are determined by state of PMD bits.
 - PWM channels 0 and 1 follow pwm generator.
- Switch 0 (On/Off) : Control by PWM0 (pwm0 frequency/duty generator).
- Switch 1 (On/Off) : Control by PWM1 (inverted of PWM0, complementary mode).
- Switch 2 (Off) : PMD.2 = 0.
- Switch 3 (On) : PMD.3 = 1.
- Switch 4 (Off) : PMD.4 = 0.
- Switch 5 (Off) : PMD.5 = 0.

In example 1.3; PME[5:0] = 11 0011b, PMD[5:0] = 10xx00b (complementary mode)

- PWM channels 0, 1, 4 and 5 are masked from pwm frequency/duty generators.
 - PWM channels 0, 1, 4 and 5 outputs are determined by state of PMD bits.
 - PWM channels 2 and 3 follow pwm generator.
- Switch 0 (Off) : PMD.0 = 0.
- Switch 1 (Off) : PMD.1 = 0.
- Switch 2 (On/Off) : Control by PWM2 (pwm2 frequency/duty generator).
- Switch 3 (On/Off) : Control by PWM3 (inverted of PWM2, complementary mode).
- Switch 4 (Off) : PMD.4 = 0.
- Switch 5 (On) : PMD.5 = 1.

In example 2.1; PME[5:0] = 11 1110b, PMD[5:0] = 00100xb (independent mode)

- PWM channels 1-5 are masked from pwm frequency/duty generators.
 - PWM channels 1-5 outputs are determined by state of PMD bits.
 - PWM channel 0 follow pwm generator.
- Switch 0 (On/Off) : Control by PWM0 (pwm0 frequency/duty generator).
- Switch 1 (Off) : PMD.1 = 0.
- Switch 2 (Off) : PMD.2 = 0.
- Switch 3 (On) : PMD.3 = 1.
- Switch 4 (Off) : PMD.4 = 0.
- Switch 5 (Off) : PMD.5 = 0.

In example 2.3; PME[5:0] = 11 1011b, PMD[5:0] = 100x00b (independent mode)

- PWM channels 0,1,3,4 and 5 are masked from pwm frequency/duty generators.
 - PWM channels 0,1,3,4 and 5 outputs are determined by state of PMD bits.
 - PWM channel 2 follow pwm generator.
- Switch 0 (Off) : PMD.0 = 0.
- Switch 1 (Off) : PMD.1 = 0.
- Switch 2 (On/Off) : Control by PWM2 (pwm2 frequency/duty generator).



Switch 3 (Off) : PMD.3 = 0.
Switch 4 (Off) : PMD.4 = 0.
Switch 5 (On) : PMD.5 = 1.

新唐科技 NUVOTON
INTELLECTUAL PROPERTY

新唐科技 NUVOTON
INTELLECTUAL PROPERTY

Preliminary N79E875 Data Sheet



25.8 SFR of PWM Unit

SYMBOL	DEFINITION	ADDRESS	BIT ADDRESS, SYMBOL								RESET
PWM6H	PWM 6 HIGH BITS REGISTER	FEH		-			PWM6.11	WM6.10	PWM6.9	PWM6.8	XXXX 0000b
PWM6L	PWM 6 LOW BITS REGISTER	FDH	PWM6.7	PWM6.6	PWM6.5	PWM6.4	PWM6.3	PWM6.2	PWM6.1	PWM6.0	0000 0000b
PWMCON4	PWM CONTROL REGISTER 4	FCH	BK1FILT.1	BK1FILT.0	BK0FILT.1	BK0FILT.0	AUTOBK1	-	BKEN1	BKEN0	0000 0X00b
PMD	PWM MASK DATA REGISTER	EEH	-	-	PMD.5	PMD.4	PMD.3	PMD.2	PMD.1	PMD.0	XX00 0000b
PME	PWM MASK ENABLE REGISTER	EDH	-	-	PME.5	PME.4	PME.3	PME.2	PME.1	PME.0	XX00 0000b
PWMB	PWM BRAKE OUTPUT	DFH	-	-	PWM5B	PWM4B	PWM3B	PWM2B	PWM1B	PWM0B	XX00 0000b
PWM2L	PWM 2 LOW BITS REGISTER	DDH	PWM2.7	PWM2.6	PWM2.5	PWM2.4	PWM2.3	PWM2.2	PWM2.1	PWM2.0	0000 0000b
PWMCON1	PWM CONTROL REGISTER 1	DCH	PWMRUN	LOAD	PWMF	CLRPWM	FBK1	FBK0	PMOD.1	PMOD.0	0000 0000b
PWM0L	PWM 0 LOW BITS REGISTER	DAH	PWM0.7	PWM0.6	PWM0.5	PWM0.4	PWM0.3	PWM0.2	PWM0.1	PWM0.0	0000 0000b
PWMP	PWM COUNTER LOW REGISTER	D9H	PWMP0.7	PWMP0.6	PWMP0.5	PWMP0.4	PWMP0.3	PWMP0.2	PWMP0.1	PWMP0.0	0000 0000b
PWMCON3	PWM CONTROL REGISTER 3	D7H	HZ_Even	HZ_Odd	GRP	PWMTYPE	-	-	P6CTRL	INT_TYPER	XX00 XX00b
PWM2H	PWM 2 HIGH BITS REGISTER	D5H	-	-	-	-	PWM2.11	PWM2.10	PWM2.9	PWM2.8	XXXX 0000b
PWM0H	PWM 0 HIGH BITS REGISTER	D2H	-	-	-	-	PWM0.11	PWM0.10	PWM0.9	PWM0.8	XXXX 0000b
PWMPH	PWM COUNTER HIGH REGISTER	D1H	-	-	-	-	PWMP.11	PWMP.10	PWMP.9	PWMP.8	XXXX 0000b
PNP	PWM NEGATIVE POLARITY	C3H	-	-	PNP.5	PNP.4	PNP.3	PNP.2	PNP.1	PNP.0	XX00 0000b
P3	PORT 3	B0H	(B7) P3.7 OPN	(B6) P3.6 OPP	(B5) P3.5	(B4) P3.4	(B3) P3.3 PWM7	(B2) P3.2 PWM5	(B1) P3.1 PWM3	(B0) P3.0 PWM1	1111 1111b ⁽¹⁾ 0000 0000b
PDTC0	PWM DEAD TIME CONTROL 0 REGISTER	AEH	-	-	-	-	-	DTENB4	DTENB2	DTENB0	XXXX X000b
DTCNT	PWM DEAD TIME COUNTER REGISTER	ABH	DTCNT.7	DTCNT.6	DTCNT.5	DTCNT.4	DTCNT.3	DTCNT.2	DTCNT.1	DTCNT.0	0000 0000b
P2	PORT 2	A0H	(A7) P2.7 T1	(A6) P2.6 IC2 MOSI	(A5) P2.5 IC1 MISO	(A4) P2.4 IC0 /SS	(A3) P2.3 T3 SCLK	(A2) P2.2 PWM4	(A1) P2.1 PWM2 CP10	(A0) P2.0 PWM0 CP20	1111 1111b ⁽¹⁾ 0000 0000b
PIO	PWM IO REGISTER	9BH	PIO.7	PIO.6	PIO.5	PIO.4	PIO.3	PIO.2	PIO.1	PIO.0	0000 0000b
PWM4H	PWM 4 HIGH BITS REGISTER	97H	-	-	-	-	PWM4.11	PWM4.10	PWM4.9	PWM4.8	XXXX 0000b
PWM4L	PWM 4 LOW BITS REGISTER	96H	PWM4.7	PWM4.6	PWM4.5	PWM4.4	PWM4.3	PWM4.2	PWM4.1	PWM4.0	0000 0000b

Note:

1. If config0.PRHI=1, the initial value is FfH at reset. If config0.PRHI=0, the initial value is 00h at reset

26 ANALOG-TO-DIGITAL CONVERTER (ADC)

N79E875 series support a 10-bit analog-to-digital converter (ADC) which contains a DAC which converts the contents of a successive approximation register to a voltage (V_{DAC}) which is compared to the analog input voltage (V_{in}). The output of the comparator is fed to the successive approximation control logic which controls the successive approximation register. This is illustrated in the figure below.

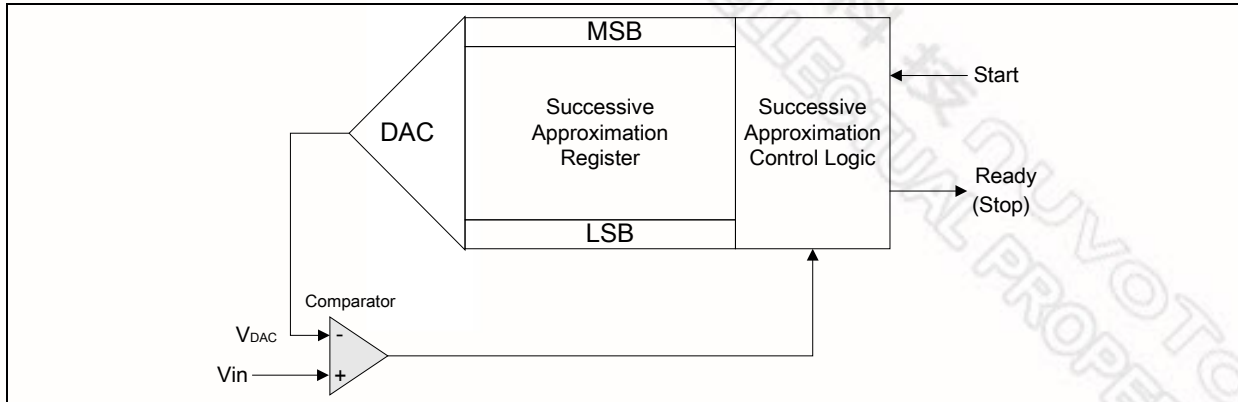

Figure 26-1: Successive Approximation ADC

26.1 Operation of ADC

26.1.1 Normal Operation of ADC

A conversion can be initiated by software only or by either hardware or software. The software only start mode is selected when control bit ADCCON.5 (ADCEX)=0. A conversion is then started by setting control bit ADCCON.3 (ADCS). The hardware or software start mode is selected when ADCEX =1, and a conversion may be started by setting ADCS as above or by applying a rising edge to external pin STADC(P1.7) or by a trigger signal synchronous with PWM unit. When a conversion is started by applying a rising edge, a low level must be applied to STADC for at least one machine cycle followed by a high level for at least one machine cycle. When ADCCON.5 (ADCEX) is set by external pin to start ADC conversion, after N79E875 series have entered idle mode, STADC/P1.7 can start ADC conversion at least 1 machine cycle.

The end of the 10-bit conversion is flagged by control bit ADCCON.4 (ADCI). The upper 8 bits of the result are held in special function register ADCH, and the two remaining bits are held in ADCCON.7 (ADC.1) and ADCCON.6 (ADC.0). The user may ignore the two least significant bits in ADCCON and use the ADC as an 8-bit converter (8 upper bits in ADCH). In any event, the total actual conversion time is **34 ADC clock cycles**. ADCI flag is set at end of ADC conversion. ADCS will be hardware cleared when ADCI is set.

Control bits ADCCON.0, ADCCON.1 and ADCCON.2 are used to control an analog multiplexer which selects one of eight analog channels. An ADC conversion in progress is unaffected by an external or software ADC start. The result of a completed conversion remains unaffected provided ADCI = logic 1.

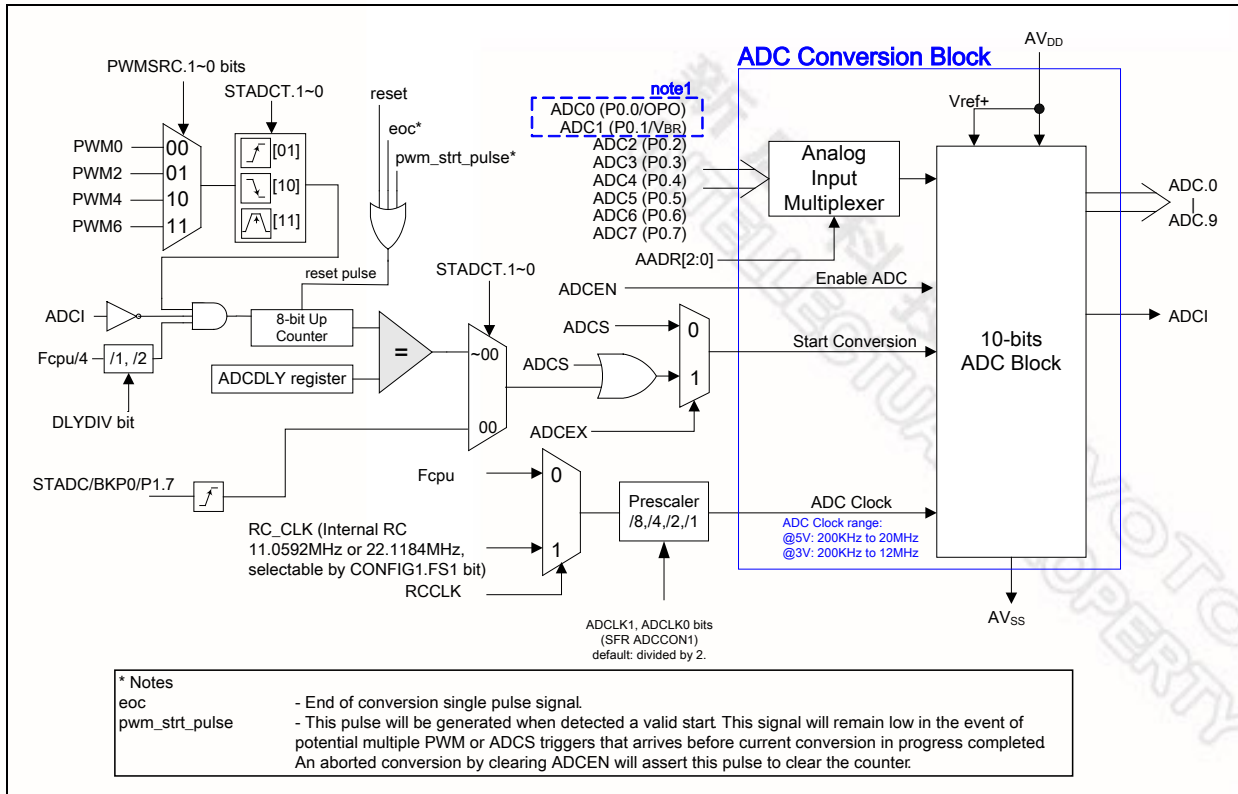

Figure 26-2: ADC Block Diagram

Note:

- The ADC0 alternative input source will come from OP Amplifier output when AUXR2.ENOP bit is enabled. See section OP Amplifier for detail. User is recommended to set SFR PADIDS.0 to disable digital input when enable ENOP. See Figure 26-3 for ADC0 and ADC1 source selection.
- The ADC1 alternative input source will come from Brownout Reference Voltage, V_{BR} . It can be selected through AUXR2.ADC1SEL bit. Refer to Figure 28-1: Comparators block diagram for the detail.

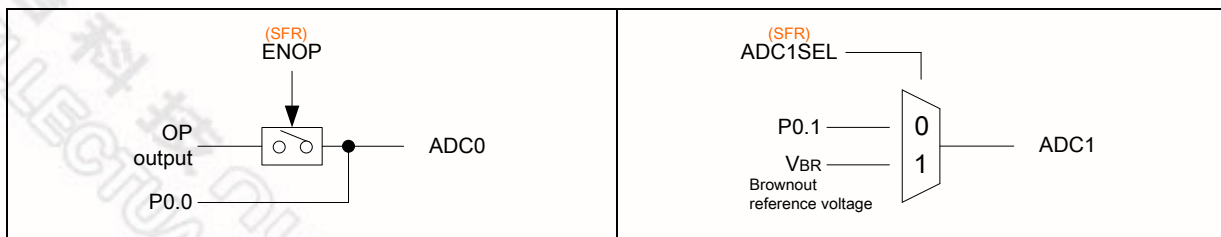

Figure 26-3: ADC0 and ADC1 source selections.

26.1.2 ADC Start Synchronous with PWM

Besides software start and external pin STADC (P1.7) to start ADC conversion, this device has new feature to allow PWM **even channels** to trigger the ADC start. User may configure any one of the PWM as well as trigger types; rising, falling PWM edge or central point of PWM (centre-aligned mode only) to trigger ADC start. The device also allow user to configure the amount of delay prior to ADC start after hardware detected the PWM edge. See SFR ADCCON1 and ADCDLY for bits descriptions. Figure below shows the programmable delay time for PWM-triggered ADC start conversion. For PWM trigger ADC start conversion in centre align mode, ADC start conversion point will be at the same, regardless of which pwm channel is selected.

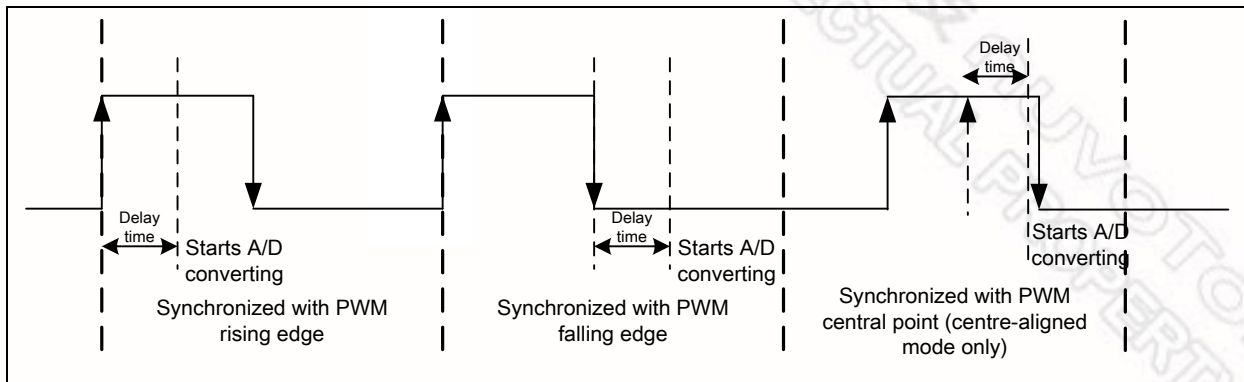

Figure 26-4: PWM-triggered ADC start

26.1.3 ADC Converting in Power-down and Idle Mode

When ADC is operating a conversion, the noise induced by CPU clock effects the ADC resolution. N79E875 series allows ADC converting in Power-down and Idle modes to minimize the noise from CPU. Software may enable ADC Interrupt in advanced then set ADCS=1 to start converting and follow setting PD=1(PCON.1) or IDL=1(PCON.0) to force CPU entering power-down or idle mode. When the conversion is completed, hardware requests ADC interrupt and release CPU from power-down or idle mode. Note that due to CPU clock stops in power-down mode, software must set RCCLK=1 to select ADC clock is from internal RC oscillator before CPU enter power-down mode.

26.2 ADC Resolution and Analog Supply:

The ADC circuit has its own supply pins (AVDD and AVSS) and one pins (Vref+) connected to each end of the DAC's resistance-ladder that the AVDD and Vref+ are connected to VDD and AVSS is connected to VSS. The ladder has 1023 equally spaced taps, separated by a resistance of "R". The first tap is located 0.5xR above AVss, and the last tap is located 0.5xR below Vref+. This gives a total ladder resistance of 1024xR. This structure ensures that the DAC is monotonic and results in a symmetrical quantization error.

For input voltages between AVss and [(Vref+) + 1/2 LSB], the 10-bit result of an A/D conversion will be 0000000000B = 000H. For input voltages between [(Vref+) - 3/2 LSB] and Vref+, the result of a conversion will be 1111111111B = 3FFH. Vref+ and AVSS may be between AVDD + 0.2V and AVSS - 0.2 V. Vref+ should be positive with respect to AVSS, and the input voltage (Vin) should be between Vref+ and AVSS.

The result can always be calculated from the following formula:

$$\text{Result} = 1024 \times \frac{V_{in}}{V_{ref+}} \quad \text{or} \quad \text{Result} = 1024 \times \frac{V_{in}}{V_{DD}}$$

26.3 ADC Continuous Mode

If ADC continuous mode is enabled, a repeated conversion of the selected channel will be performed until ADCCM or ADCS bit is cleared and the new 10-bit result will overwrite the old data. Unlike the normal ADC function ADCS is cleared automatically at the end of a conversion, in this mode, ADCS keeps high till software clear it or ADCCM is cleared and the last conversion is completed. Figure below explains the behavior of the ADC continuous mode.

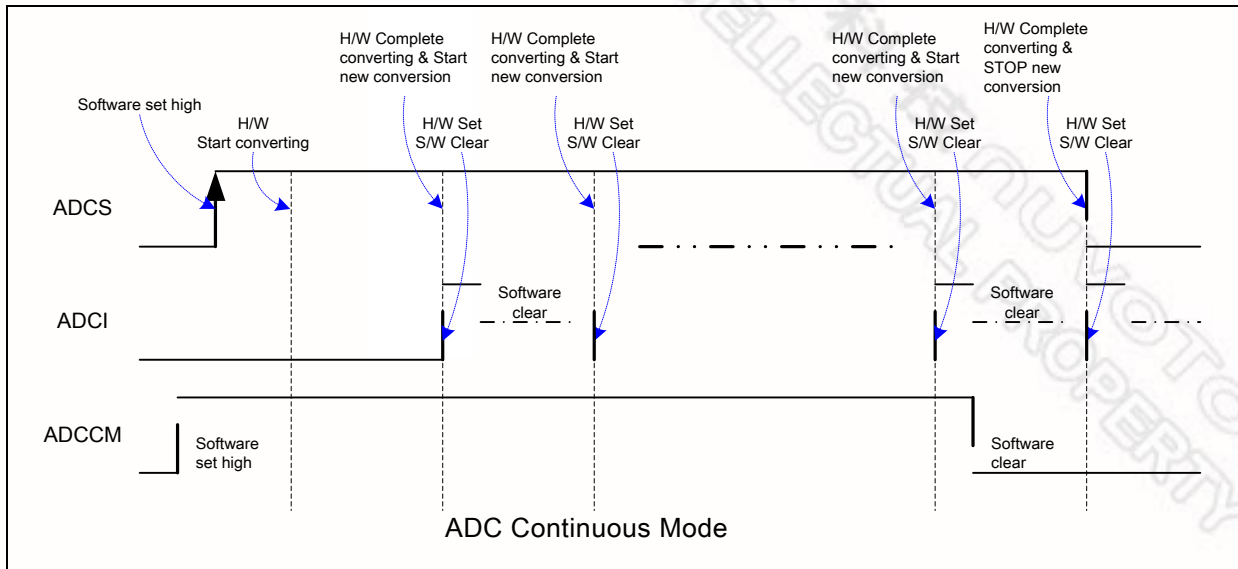

Figure 26-5: ADC Continuous Mode

26.4 ADC Compare Function

N79E875 ADC provides the compare function that compares the 10-bit ADC result and an arbitrary 10-bit reference data. The compare result places in ADCPO bit. When the new conversion result makes ADCPO bit change state, the ADCPI flag is set by H/W and an ADC interrupt is requested if EADCP bit is set in advanced. The block diagram of ADC compare function is shown in the following figure.

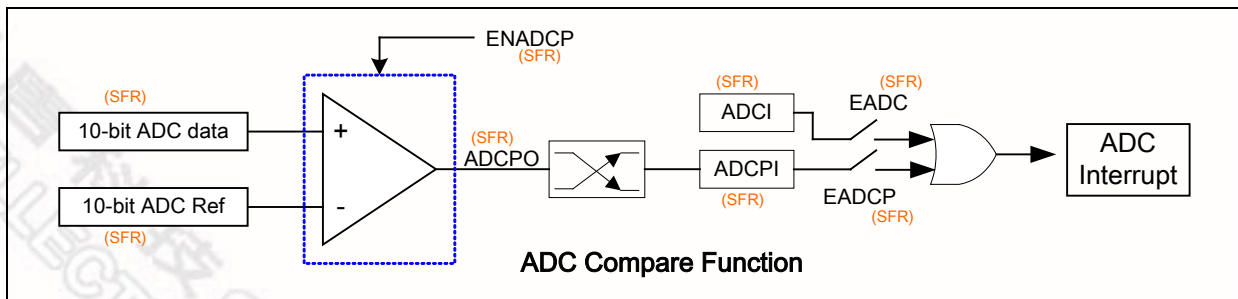

Figure 26-6: ADC Compare Function



The 10-bit reference data ADCR.9-0 bits (located at SFR ADCRH.7-0 and ADCRL.7-6) are writable only when ENADCP = 0. User will have to take of potential false trigger when changing the reference data. The following is the recommended procedure note when using ADC Compare function.

1. Disable ADC compare function (ENADCP=0).
2. Disable ADC compare function interrupt (EADCP=0).
3. Update 10-bit ADC Ref registers.
4. Clear ADCPI flag (this is to avoid unwanted compare trigger due to new reference data).
5. Enable ADC compare function (ENADCP=1).
6. Enable compare function interrupt (EADCP=1).
7. Start next ADC conversion.

27 OP AMPLIFIER

This device integrated an operational amplifier. It can be enabled through SFR OPCON.ENOP bit. User can measure the output of the operational amplifier as the operation amplifier output to the integrated analog digital convert channel 0, where digital result can be taken.

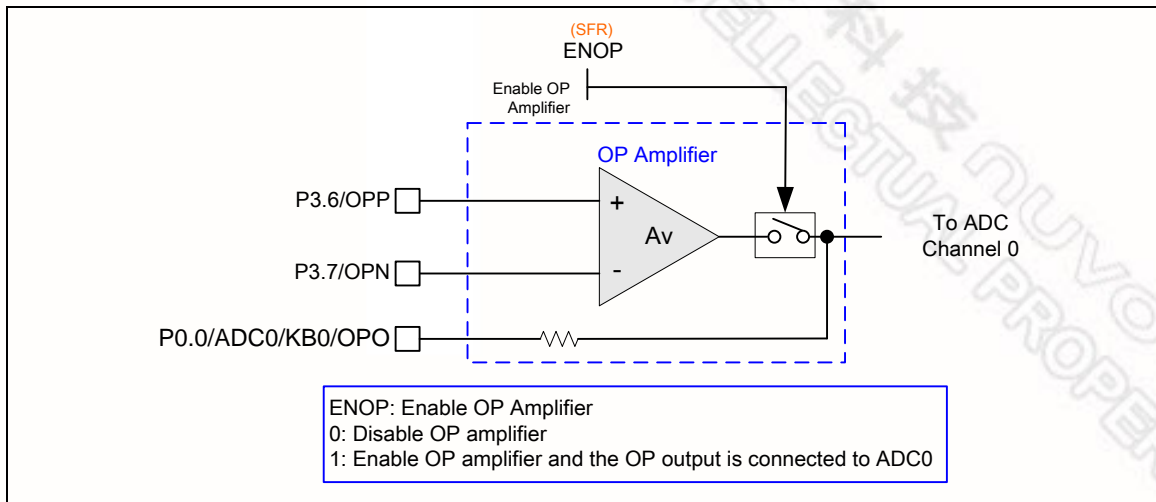

Figure 27-1: Operation Amplifier block diagram

Note:

- User is required to set AUXR2.POPDIDS bit to disable digital input at P3.6 (OPP) and P3.7 (OPN) pins, when using OP Amplifier.
- The ADC0 alternative input source will come from OP Amplifier output when AUXR2.ENOP bit is enabled. User is recommended to set SFR PADIDS.0 to disable digital input when enable ENOP.

28 ANALOG COMPARATORS

This device is also provided with two comparators. The comparators can be used in a number of different configurations. The comparator output is a logical one when positive input greater than negative input, otherwise the output is a zero. Each comparator can be configured to cause to an interrupt when the comparator output value changes. The block diagram is as below.

The inputs are CPnP and CPnN, and outputs CPnO (n = 1 or 2). User may select the internal reference voltage by enable SFR CMPn.CNn bit. The typical value of internal brownout reference voltage (V_{BR}) is about 1.16V +/- 10%.

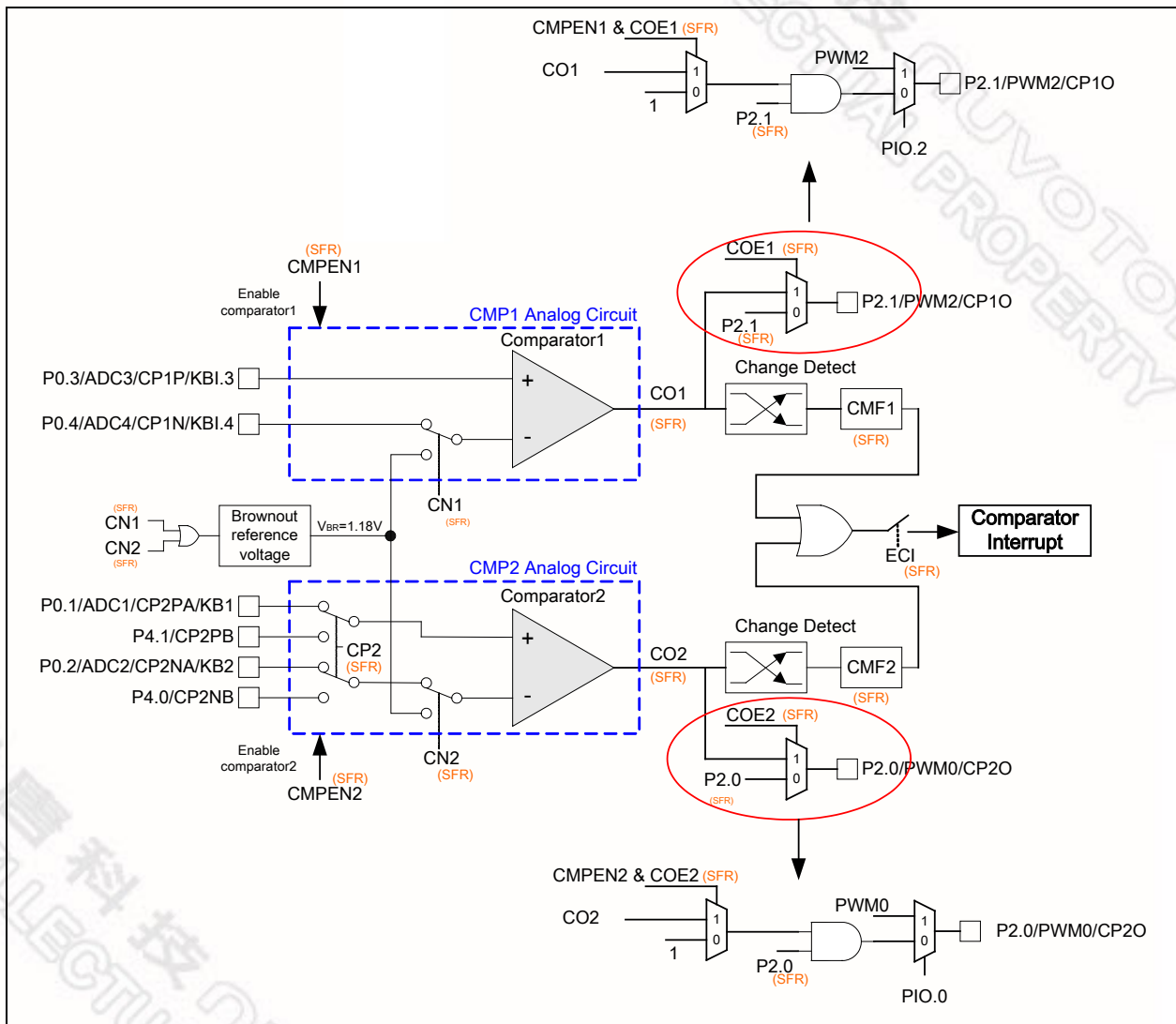

Figure 28-1: Comparators block diagram

Note: When using the both comparators, user should set SFR PADIDS.1-2, PADIDS.3-4 or AUXR2.4-5 bits accordingly to disable digital input at the comparators' input pins.

Both comparators have hysteresis function that is controllable through HYSEN1 and HYSEN2 bits.

29 ICP (IN-CIRCUIT PROGRAM) FLASH PROGRAM

The ICP(In-Circuit-Program) mode is another approach to access the Flash EPROM. There are only 3 pins needed to perform the ICP function. One is mode input, shared with /RST pin, which is up to 11 volt in ICP working period. One is clock input, shared with P0.5, which accepts serial clock from external device. Another is data I/O pin, shared with P0.4, that an external ICP program tool shifts in/out data via P0.4 synchronized with clock(P0.5) to access the Flash EPROM of N79E875 series. User may refer to <http://www.manley.com.cn/english/index.asp> for ICP Program Tool.

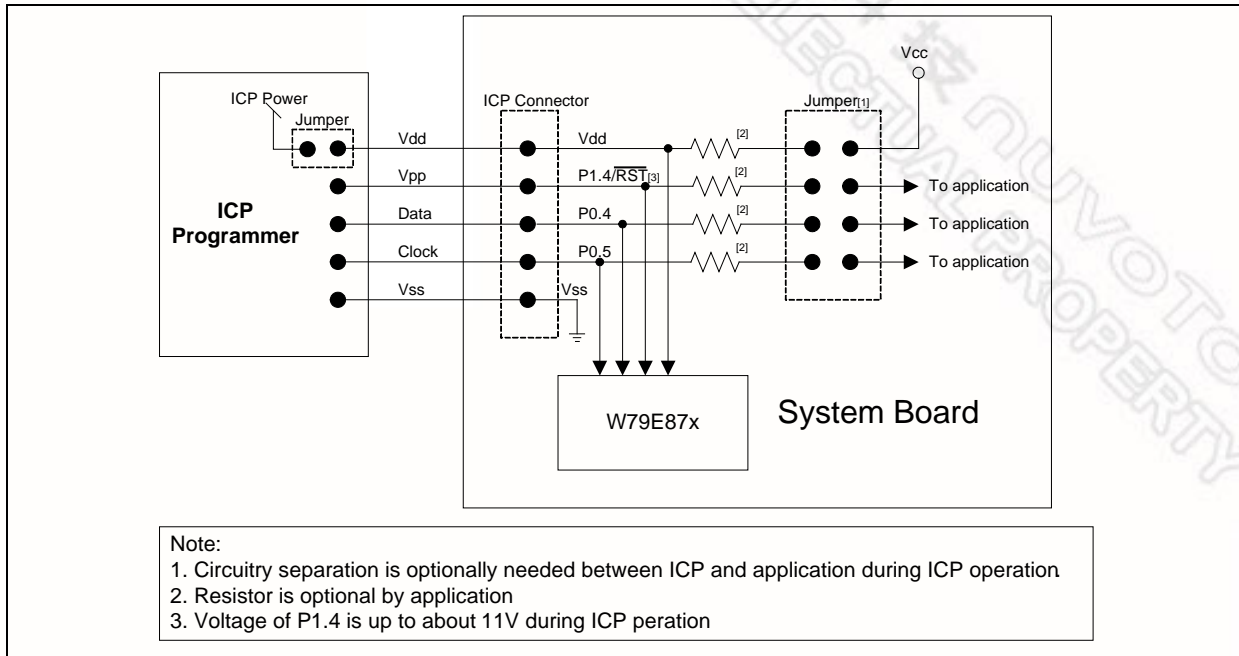

Notes:

- When using ICP to upgrade code, the P1.4, P0.4 and P0.5 must be taken within design system board.
- After program finished by ICP, to suggest system power must be off and remove ICP connector then power on.
- It is recommended that user performs erase function and programming configure bits continuously without any interruption.
- During ICP mode, all PWM pins will be tri-stated.



30 CONFIG BITS

The N79E875 series has two CONFIG bits (CONFIG0 located at FB00h, CONFIG1 located at FB01h) that must be defined at power up and can not be set the program after start of execution. Those features are configured through the use of two flash EPROM bytes, and the flash EPROM can be programmed and verified repeatedly. Until the code inside the Flash EPROM is confirmed OK, the code can be protected. The protection of flash EPROM (CONFIG1) and those operations on it are described below. The data of these bytes may be read by the MOVX instruction at the addresses.

30.1 CONFIG0

CONFIG0

Bit: 7 6 5 4 3 2 1 0

WDTCK	RPD	PRHI	CBOV1	CBOV0	BPFR	Fosc1	Fosc0
-------	-----	------	-------	-------	------	-------	-------

BIT	NAME	FUNCTION
7	WDTCK	Clock source of Watchdog Timer select bit: 0: The internal 500KHz RC oscillator clock is for Watchdog Timer clock used. 1: The uC clock is for Watchdog Timer clock used.
6	RPD	Reset Pin Disable bit: 0: Enable Reset function of Pin 1.4. 1: Disable Reset function of Pin 1.4, and it to be used as an input port pin.
5	PRHI	Port Reset High or Low bit: 0: Port reset to low state. 1: Port reset to high state.
4-3	CBOV.1-0	Brownout Voltage Select bits: 00: Brownout detect voltage is 4.5V. 01: Brownout detect voltage is 3.8V. 1x: Brownout detect voltage is 2.6V (default).
2	BPFR	Bypass Clock Filter of Crystal Oscillator bit: 0: Disable Clock Filter. 1: Enable Clock Filter. (default)



1-0	Fosc1-0	CPU Oscillator Type Select bits		
		FOSC1	FOSC0	OSC SOURCE
		0	0	4MHz ~ 40MHz crystal
		0	1	Internal RC Oscillator, 22.1184MHz/11.0592MHz
		1	0	Reserved
1	1	External Oscillator in XTAL1		



30.2 CONFIG1

CONFIG1

Bit: 7 6 5 4 3 2 1 0

C7	C6	FS1	-	SCF	-	PWM_Even	PWM_Odd
----	----	-----	---	-----	---	----------	---------

BIT	NAME	FUNCTION
7	C7	16K-Byte AP Flash EPROM Lock bit: 0: The 16K-byte embedded AP Flash EPROM and Config registers are protected from reading through any programming tool. 1: The 16-byte embedded AP Flash and Config registers are not locked that can be read by external programming tool.
6	C6	128-Byte Data Flash Lock bit: 0: The 128-byte Data Flash is protected from reading through any programming tool. 1: The 128-byte Data Flash is not locked that can be read by external programming tool. Refer to the below table for more detail.
5	FS1	Internal Oscillator 22.1184MHz/11.0592MHz select bit 0: Internal OSC frequency is 11.0592MHz. 1: Internal OSC frequency is 22.1184MHz.(default)
4	Reserved	Reserved bit and must be kept high.
3	SCF	Select Crystal Frequency: This bit is used to adjust the oscillation circuit to meet the external crystal frequency. 0: For external crystal frequency < 24MHz. 1: For external crystal frequency > 24MHz.
2	Reserved	Reserved bit and must be kept high.
1	PWM_Even	PWM Even channels driving mode select bit 1: The driving mode of even PWM pins is forced to Hi-Z mode all the time. 0: The driving mode of even PWM pins is controlled by output mode register (PxMy). This bit is latched to SFR PWMCON3.HZ_Even after all reset.

0	PWM_Odd	<p>PWM Odd channels driving mode select bit</p> <p>1: The driving mode of odd PWM pins is forced to Hi-Z mode all the time.</p> <p>0: The driving mode of odd PWM pins is controlled by output mode register (PxMy).</p> <p>This bit is latched to SFR PWMCON3.HZ_Odd after all reset.</p>
---	---------	--

Lock bits control list:

Bit 7	Bit 6	Function Description
1	1	Both security of 16K-byte AP Flash and 128-byte Data Flash are not locked. They can be erased, programmed or read by Writer, ICP or JTAG mode.
0	1	<p>The 16K-byte AP Flash is locked but 128-byte Data Flash is not locked.</p> <p><u>16K-byte AP Flash:</u></p> <ul style="list-style-type: none"> It can't be read by Writer, ICP or JTAG mode. <p><u>128-byte Data Flash:</u></p> <ul style="list-style-type: none"> It can still support program or read by Writer, ICP or JTAG mode. Bank erase of this data area is supported in ICP.
1	0	Not supported.
0	0	Both security of 16K-byte AP Flash and 128-byte Data Flash are locked. They can't be read by Writer, ICP or JTAG mode.



31 ELECTRICAL CHARACTERISTICS

31.1 Absolute Maximum Ratings

SYMBOL	PARAMETER	MIN	MAX	UNIT
DC Power Supply	VDD-VSS	-0.3	+7.0	V
Input Voltage	VIN	VSS-0.3	VDD+0.3	V
Oscillator Frequency	1/t _{CLCL}	0	40	MHz
Operating Temperature	TA	-40	+85	°C
Storage Temperature	TST	-55	+150	°C
Maximum Current into V _{DD}		-	120	mA
Maximum Current out of V _{SS}			120	mA
Maximum Current sunk by a I/O pin			35	mA
Maximum Current sourced by a I/O pin			35	mA
Maximum Current sunk by total I/O pins			100	mA
Maximum Current sourced by total I/O pins			100	mA

Note: Exposure to conditions beyond those listed under absolute maximum ratings may adversely affects the lift and reliability of the device.

31.2 DC Electrical Characteristics

(TA = -40~85°C, unless otherwise specified.)

PARAMETER	SYM.	SPECIFICATION				TEST CONDITIONS
		MIN.	TYP.	MAX.	UNIT	
Operating Voltage	V _{DD}	2.4		5.5	V	V _{DD} = 4.5V ~ 5.5V up to 40MHz V _{DD} = 3.0V ~ 5.5V up to 24MHz V _{DD} = 2.4V ~ 5.5V up to 8MHz
		3.0	-	5.5		Program and erase Data Flash.
Operating Current	I _{DD1}	15		22	mA	V _{DD} = 5.0V @ 40MHz, No load, /RST = V _{SS}
				7.5	mA	V _{DD} = 3.0V @ 24MHz, No load, /RST = V _{SS}
	I _{DD2}			40	mA	V _{DD} = 5.0V @ 40MHz, No load, /RST = V _{DD} , Run NOP
				12	mA	V _{DD} = 3.0V @ 24MHz, No load, /RST = V _{DD} , Run NOP
Idle Current	I _{IDLE}			22	mA	V _{DD} = 5.5V, 40MHz, no load
				7	mA	V _{DD} = 3.0V, 24MHz, no load
Power Down Current	I _{PWDN}		1	10	μA	V _{DD} = 5.5V, no load @ Disable BOV function
			1	10	μA	V _{DD} = 3.0V, no load @ Disable BOV function
			130		μA	V _{DD} = 5.0V, no load, 25°C With BOV function LPBOD=0
			80		μA	V _{DD} = 5.0V, no load, 25°C With BOV function LPBOD=1
Input Current P0, P1, P2, P3, P4	I _{IN1}	-50	-	+15	μA	V _{DD} = 5.5V, V _{IN} = 0V or V _{IN} = V _{DD}
Input Current P1.4(/RST pin) ^[1]	I _{IN2}	-55	-45	-30	μA	V _{DD} = 5.5V, V _{IN} = 0.45V
Input Leakage Current P0, P1, P2 (Open Drain), P3, P4	I _{LK}	-2	-	+2	μA	V _{DD} = 5.5V, 0 < V _{IN} < V _{DD}
Logic 1 to 0 Transition Current P0, P1, P2, P3, P4	I _{TL} ^[3]	-500	-	-200	μA	V _{DD} = 5.5V, V _{IN} < 2.0V
Input Low Voltage P0, P1, P2, P3, P4 (TTL input)	V _{IL1}	0	-	1.0	V	V _{DD} = 4.5V
		0	-	0.6		V _{DD} = 2.4V
Input High Voltage P0, P1, P2, P3, P4 (TTL input)	V _{IH1}	2.2	-	V _{DD} + 0.2	V	V _{DD} = 5.5V
		1.5	-	V _{DD} + 0.2		V _{DD} = 3.0V
Input Low Voltage XTAL1 ^[2]	V _{IL3}	0	-	0.8	V	V _{DD} = 4.5V
		0	-	0.4		V _{DD} = 3.0V
Input High Voltage XTAL1 ^[2]	V _{IH3}	3.5	-	V _{DD} + 0.2	V	V _{DD} = 5.5V
		2.4	-	V _{DD} + 0.2		V _{DD} = 3.0V
Negative going threshold (Schmitt input), /RST	V _{ILS}	-0.5	-	0.3V _{DD}	V	

Preliminary N79E875 Data Sheet



Positive going threshold (Schmitt input), /RST	V_{IHS}	$0.7V_{DD}$	-	$V_{DD}+0.5$	V	
Hysteresis voltage	V_{HY}		$0.2V_{DD}$		V	
Source Current P0, P1, P2, P3, P4 (Quasi-bidirectional Mode)	I_{SR11}	-150	-210	-360	μA	$V_{DD} = 4.5V, V_S = 2.4V$
	I_{SR12}	-35	-40	-60	μA	$V_{DD} = 2.7V, V_S = 2.2V$
	I_{SR12}	-18	-27	-40	μA	$V_{DD} = 2.4V, V_S = 2.0V$
Source Current P0, P1, P2, P3, P4 (Push-pull Mode)	I_{SR21}	12	16	20	mA	$V_{DD} = 4.5V, V_S = 3.0V$
	I_{SR22}	6	8	10	mA	$V_{DD} = 2.7V, V_S = 2.2V$
	I_{SR22}	2.5	3.5	4.5	mA	$V_{DD} = 2.4V, V_S = 2.0V$
Sink Current P0, P1, P2, P3, P4 (Quasi-bidirectional and Push-pull Mode)	I_{SK1}	18	25	32	mA	$V_{DD} = 4.5V, V_S = 0.45V$
	I_{SK1}	15	20	25	mA	$V_{DD} = 2.7V, V_S = 0.45V$
	I_{SK1}	13	17	21	mA	$V_{DD} = 2.4V, V_S = 0.45V$
Brownout voltage with BOV[1:0] = 0xb	$V_{BO2.5}$	2.40	2.5	2.60	V	
Brownout voltage with BOV[1:0] = 10b	$V_{BO3.8}$	3.60	3.75	3.90	V	
Brownout voltage with BOV[1:0] = 11b	$V_{BO4.5}$	4.30	4.5	4.70	V	
Hysteresis range of BOD voltage	V_{Bh}	50	-	140	mV	$V_{DD} = 2.4V \sim 5.5V$

Notes:

1. /RST pin is a Schmitt trigger input.
2. XTAL1 is a CMOS input.
3. Pins of P0, P1, P2, P3 and P4 can source a transition current when they are being externally driven from 1 to 0. The transition current reaches its maximum value when V_{in} approximates to 2V.

31.3 ADC Converter DC Electrical Characteristics

($V_{DD}-V_{SS} = 3.3-5V$, $T_A = -40-85^{\circ}C$, ADC clock=12MHz, AV_{DD} is independent¹, unless otherwise specified.)

PARAMETER	SYMBOL	SPECIFICATION				TEST CONDITIONS
		MIN.	TYP.	MAX.	UNIT	
Analog input	AV_{in}	$AV_{SS}-0.2$		$AV_{DD}+0.2$	V	
ADC clock	ADCCLK	200KHz	-	20MHz	Hz	$V_{DD} = 5.0V.$
				12MHz		$V_{DD} = 3.3V.$
ADC Current consumption (ADC enable)	I_{ADC}		3.0		mA	$V_{DD}=5.0V$ ADCCLK=11.059Mhz ADC input=GND
	I_{ADC}		2.2		mA	$V_{DD}=3.3V$ ADCCLK=11.059Mhz ADC input=GND
Conversion time	t_c		$34t_{ADC}^2$		us	
Differential non-linearity	DNL	-1	-	+1	LSB	
Integral non-linearity	INL	-2	-	+2	LSB	
Offset error	Ofe	-0.5	-	+3.0	LSB	
Gain error	Ge	-0.6	-	+0.1	%	
Absolute voltage error	Ae	-4	-	+4	LSB	$V_{DD} = 5.0V.$
		-5		+5		$V_{DD} = 3.3V.$

Notes:

1. AV_{DD} needs clear power*, power noise is smaller than 0.5LSB for test condition of resolution. Suggest don't connect AV_{DD} to DV_{DD} directly without any isolation device

*clear power :

For test 8-bit resolution of 10bit-SARADC, power noise need smaller than 2LSB of ADC.

If AV_{DD} is 5V, power noise need small than 9.5mV.

2. t_{ADC} : The period time of ADC input clock.



31.4 OP Amplifier Electrical Characteristics

($V_{DD}-V_{SS} = 3.0-5V$, $T_A = -40-85^{\circ}C$, $F_{cpu} = 16MHz$, unless otherwise specified.)

PARAMETERS	SPECIFICATION			UNIT	CONDITIONS
	MIN.	TYP.	MAX.		
Temperature	-40	25	85	$^{\circ}C$	
V_{DD}	2.4	-	5.5	V	
OP power current	-	-	2	mA	$V_{DD}=5V$, $T=85^{\circ}C$
Input offset voltage	-	-	± 20	mV	
Input offset average drift	-	-	1	$\mu V/^{\circ}C$	
Output swing	0.1	-	$V_{DD}-0.1$	V	
Input common mode range	0.1	-	$V_{DD}-1.2$	V	
DC gain	-	80	-	dB	
Unity gain freq.	4	-	5.5	MHz	$V_{DD}=5V$
Phase margin	50°		-	$^{\circ}$	
PSRR+	-	90	-	dB	$V_{DD}=5V$
CMRR	-	90	-	dB	$V_{DD}=5V$
Slew rate+	-	6.0	7.5	V/us	$V_{DD}=5V$
Slew rate-	-	6.0	7.5	V/us	$V_{DD}=5V$
Wake up time	-	-	20	us	

31.5 Comparator Electrical Characteristics

($V_{DD}-V_{SS} = 3.0-5V$, $T_A = -40-85^{\circ}C$, $F_{cpu} = 16MHz$, unless otherwise specified.)

PARAMETERS	SPECIFICATION			UNIT	CONDITIONS
	MIN.	TYP.	MAX.		
Temperature	-40	25	85	$^{\circ}C$	
V_{DD}	2.4	3	5.5	V	
Power current	-	20	40	μA	
Output swing	0.1	-	$V_{DD}-0.1$	V	
Input common mode range(V_{CM})	0.1	-	$V_{DD}-1.3$	V	
DC gain	-	70	-	dB	Design guarantee
Propagation delay	-	200	-	ns	@ $V_{CM}=1V$ & $V_{DIFF}=0.1V$
Comparison voltage	10	20	-	mV	20mV@ $V_{CM}=1V$ 50mV@ $V_{CM}=0.1V$ 50mV@ $V_{CM}=V_{DD}-1.3$ @10mV for non-hysteresis
Hysteresis	-	± 20	± 35	mV	@ $V_{CM}=0.5V \sim V_{DD}-1.3V$
Wake up time	-	-	2	μs	@ $C_{INP}=0.9V$ & $C_{INN}=1V$
Brownout reference voltage ^[1] (V_{BR})	1.13 1.11	1.16 1.14	1.20 1.18	V	$V_{DD} = 5.0V$. $V_{DD} = 3.0V$.

Notes:

1. Value is guideline only and not tested.



31.6 AC Electrical Characteristics

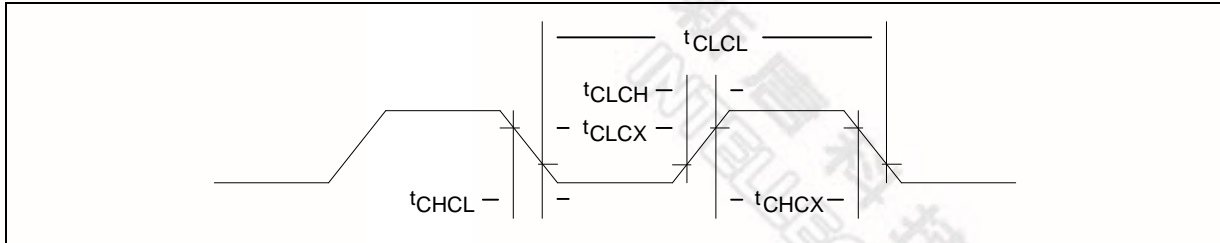

Note: Duty cycle is 50%.

31.6.1 External Clock Characteristics

PARAMETER	SYMBOL	MIN.	TYP.	MAX.	UNITS	NOTES
Clock High Time	t_{CHCX}	12.5	-	-	nS	
Clock Low Time	t_{CLCX}	12.5	-	-	nS	
Clock Rise Time	t_{CLCH}	-	-	10	nS	
Clock Fall Time	t_{CHCL}	-	-	10	nS	

31.6.2 Supplied Voltage-Frequency

Supplied Voltage V_{DD}	Operating CPU Clock			UNIT
	MIN.	TYP.	MAX.	
$V_{DD} = 4.5V \sim 5.5V$			40	MHz
$V_{DD} = 3.0V \sim 5.5V$			24	MHz
$V_{DD} = 2.4V \sim 5.5V$			8	MHz

31.6.3 Internal RC Oscillator Characteristics

($V_{DD} - V_{SS} = 2.4 - 5V$, $T_A = -40 - 85^\circ C$.)

Parameter	Specification (reference)				Test Conditions
	Min.	Typ.	Max.	Unit	
Fosc of N79E875 On-chip RC oscillator without calibration. Nominal value of Fosc is about 22MHz/11MHz.	-25		25	%	$V_{DD} = 2.4V \sim 5.5V$, $T_A = -40^\circ C \sim 85^\circ C$
Fosc of N79E875R On-chip RC oscillator with calibration ^{1,2} Nominal value of Fosc is 22.1184MHz/11.0592MHz	-2		2	%	$V_{DD} = 3.3V$, $T_A = 25^\circ C$
	-5		5	%	$V_{DD} = 2.7V \sim 5.5V$, $T_A = -20 \sim 85^\circ C$
	-8		8	%	$V_{DD} = 2.7V \sim 5.5V$, $T_A = -40 \sim 85^\circ C$
Wakeup time		256		clk	

Note:

1. These values are for design guidance only and are not tested.

31.6.4 Typical Crystal Application Circuits

CRYSTAL	C1	C2	R
>24MHz	5p~15p	5p~15p	1.8k~2.2k
4MHz ~ 24 MHz	without	without	without

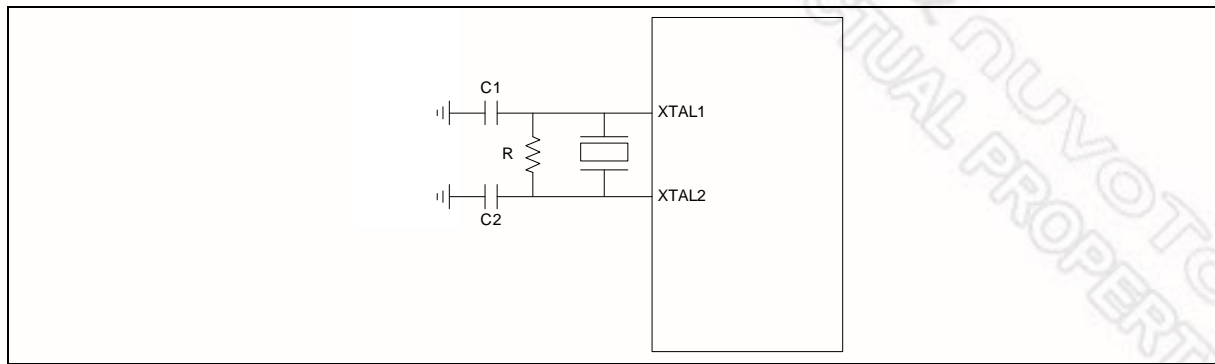
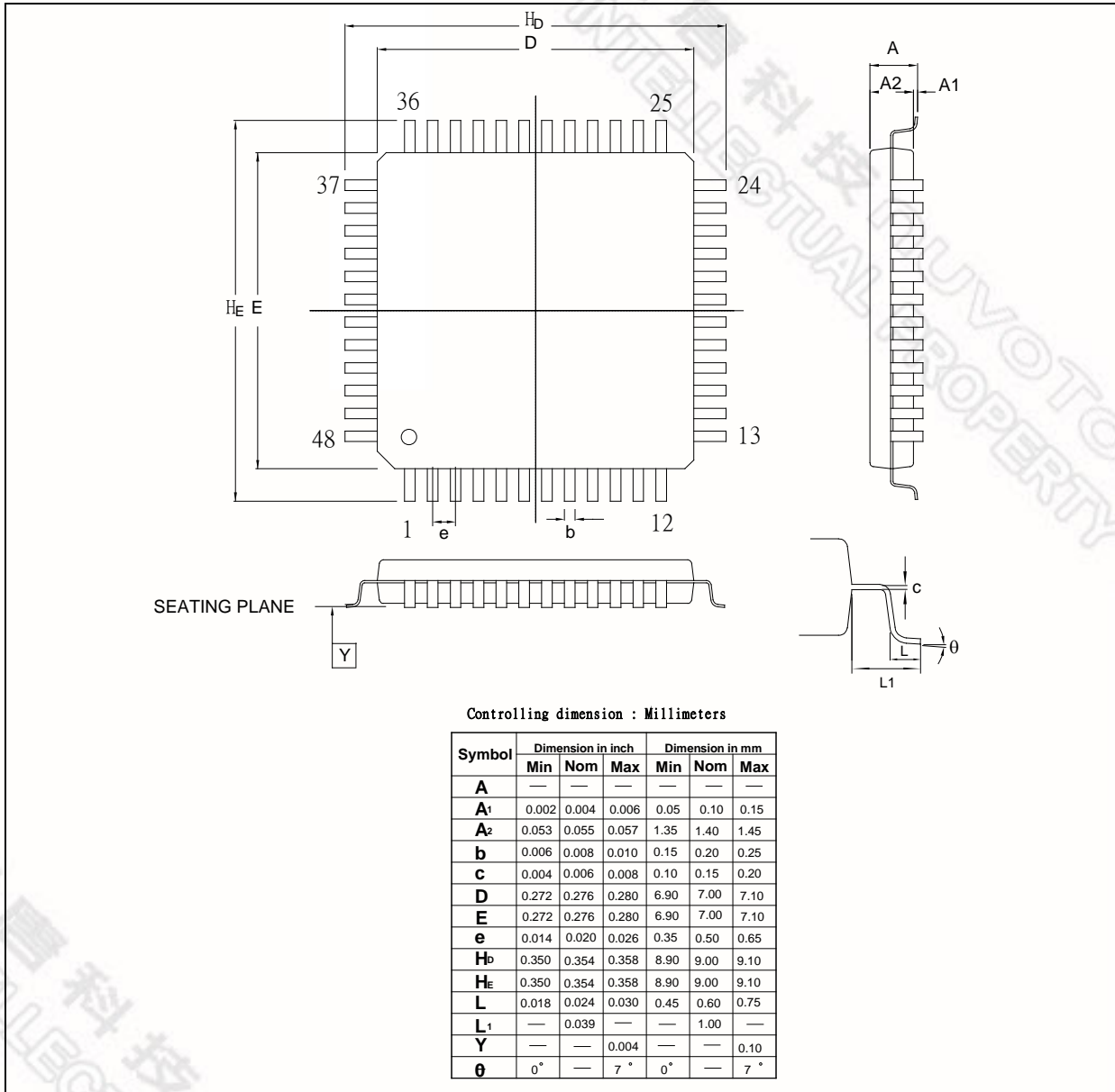

Figure 31-1 Typical Crystal Application Circuit

32 PACKAGE DIMENSIONS

32.1 48L LQFP (7x7x1.4mm footprint 2.0mm)



33 REVISION HISTORY

VERSION	DATE	PAGE/ CHAP.	DESCRIPTION
A01	December 30, 2008	-	Initial Issued
A02	April 13, 2009	All	a. Remove N79M8xx, 874 & 873 series and change 125°C to 85°C.
		All	b. Revise typos in the document.
		Ch7	c. Rename PDTC1(ABh) to DTCNT
		101	d. Revise typo in Figure 15-2. (Change P4S to P2S)
		Ch7	e. Remove "BOD = inverse (CBOD) config bit"

Important Notice

Nuvoton Products are neither intended nor warranted for usage in systems or equipment, any malfunction or failure of which may cause loss of human life, bodily injury or severe property damage. Such applications are deemed, "Insecure Usage".

Insecure usage includes, but is not limited to: equipment for surgical implementation, atomic energy control instruments, airplane or spaceship instruments, the control or operation of dynamic, brake or safety systems designed for vehicular use, traffic signal instruments, all types of safety devices, and other applications intended to support or sustain life.

All Insecure Usage shall be made at customer's risk, and in the event that third parties lay claims to Nuvoton as a result of customer's Insecure Usage, customer shall indemnify the damages and liabilities thus incurred by Nuvoton.

Please note that all data and specifications are subject to change without notice.
All the trademarks of products and companies mentioned in this datasheet belong to their respective owners.