

Philips Components-Signetics

Document No.	853-0837
ECN No.	95099
Date of Issue	November 10, 1988
Status	Product Specification
Memory Products	

82LHS191

16K-bit TTL bipolar PROM

DESCRIPTION

The 82LHS191 is field programmable, meaning that custom patterns are immediately available by following the Signetics Generic II fusing procedure. The 82LHS191 is supplied with all outputs at a logical High. Outputs are programmed to a logic Low level at any specified address by fusing the vertical junction matrix.

This device includes on-chip decoding and 3 Chip Enable inputs for ease of memory expansion. It features 3-State outputs for optimization of word expansion in bused organizations.

Ordering information can be found on the following page.

The 82LHS191 devices are also processed to military requirements for operation over the military temperature range. For specifications and ordering information consult the Signetics Military Data Book.

FEATURES

- Address access time: 35ns max
- Power dissipation: 32μW/bit typ
- Input loading: -250μA max
- Three Chip Enable Inputs
- On-chip address decoding
- No separate fusing pins
- Unprogrammed outputs are High level
- Fully TTL compatible
- Outputs: 3-State

APPLICATIONS

- Prototyping/volume production
- Sequential controllers
- Microprogramming
- Hardwired algorithms
- Control store
- Random logic
- Code conversion

BLOCK DIAGRAM

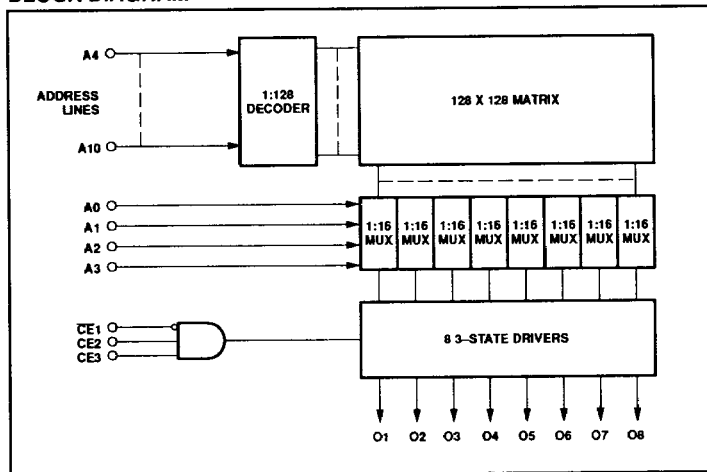

PIN CONFIGURATIONS

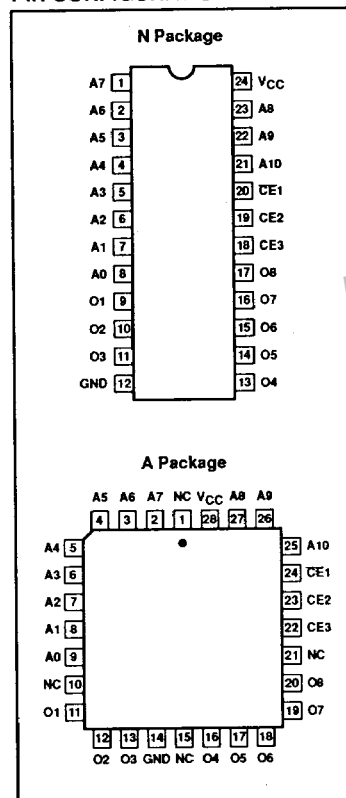

16K-bit TTL bipolar PROM (2048 × 8)**82LHS191****ORDERING INFORMATION**

PACKAGE DESCRIPTION	ORDER CODE
24-pin Plastic Dual-In-Line 600mil-wide	N82LHS191 N
24-pin Plastic Dual-In-Line 300mil-wide	N82LHS191 N3
28-pin Plastic Leaded Chip Carrier 450mil-square	N82LHS191 A

ABSOLUTE MAXIMUM RATINGS

SYMBOL	PARAMETER	RATING	UNIT
V_{CC}	Supply voltage	+7	V_{DC}
V_{IN}	Input voltage	+5.5	V_{DC}
V_O	Output voltage Off-State	+5.5	V_{DC}
T_{amb}	Operating temperature range	0 to +75	°C
T_{stg}	Storage temperature range	-65 to +150	°C

DC ELECTRICAL CHARACTERISTICS0°C ≤ T_{amb} ≤ +75°C, 4.75V ≤ V_{CC} ≤ 5.25V

SYMBOL	PARAMETER	TEST CONDITIONS ^{1,2}	LIMITS			UNIT
			Min	Typ ⁴	Max	
Input voltage						
V_{IL}	Low ³	$I_{IN} = -18mA$	2.0		0.8	V
V_{IH}	High ³					
V_{IC}	Clamp					
Output voltage						
V_{OL}	Low	$CE_1 = \text{Low}, CE_{2,3} = \text{High}$ $I_{OUT} = 16mA$ $I_{OUT} = -2mA$	2.4		0.5	V
V_{OH}	High					
Input current						
I_{IL}	Low	$V_{IN} = 0.45V$ $V_{IN} = 5.25V$			-250	μA
I_{IH}	High					
Output current						
I_{OZ}	Hi-Z state	$CE_1 = \text{High}, CE_{2,3} = \text{Low}, V_{OUT} = 0.5V$ $CE_1 = \text{High}, CE_{2,3} = \text{Low}, V_{OUT} = 5.25V$ $CE_1 = \text{Low}, CE_{2,3} = \text{High}, V_{OUT} = 0V$	-15		-40	μA
I_{OS}	Short circuit ³					
Supply current⁵						
I_{CC}		$V_{CC} = 5.25V$		100	110	mA
Capacitance						
C_{IN}	Input	$CE_1 = \text{High}, CE_{2,3} = \text{Low}$ $V_{CC} = 5.0V$ $V_{IN} = 2.0V$ $V_{OUT} = 2.0V$			5	pF
C_{OUT}	Output					
					8	pF

NOTES:

1. Positive current is defined as into the terminal referenced.
2. All voltages with respect to network ground.
3. Duration of short circuit should not exceed 1 second.
4. Typical values are at $V_{CC} = 5V$, $T_A = +25^\circ C$.
5. Measured with all inputs grounded and all outputs open.

www.DataSheet4U.com

16K-bit TTL bipolar PROM (2048 × 8)

82LHS191

AC ELECTRICAL CHARACTERISTICS

 $R_1 = 270\Omega$, $R_2 = 600\Omega$, $C_L = 30\text{pF}$, $0^\circ\text{C} \leq T_A \leq +75^\circ\text{C}$, $4.75\text{V} \leq V_{CC} \leq 5.25\text{V}$

SYMBOL	PARAMETER	TO	FROM	LIMITS			UNIT
				Min	Typ ¹	Max	
Access time²							
t_{AA}		Output	Address		30	35	ns
t_{CE}		Output	Chip Enable		15	20	ns
Disable time³							
t_{CD}		Output	Chip Disable		15	20	ns

NOTES:

- Typical values are at $V_{CC} = 5\text{V}$, $T_A = +25^\circ\text{C}$.
- Tested at an address cycle time of $1\mu\text{s}$.
- Measured at a delta of 0.5V from Logic Level with $R_1 = 750\Omega$, $R_2 = 750\Omega$, $C_L = 5\text{pF}$.

TEST LOAD CIRCUITS

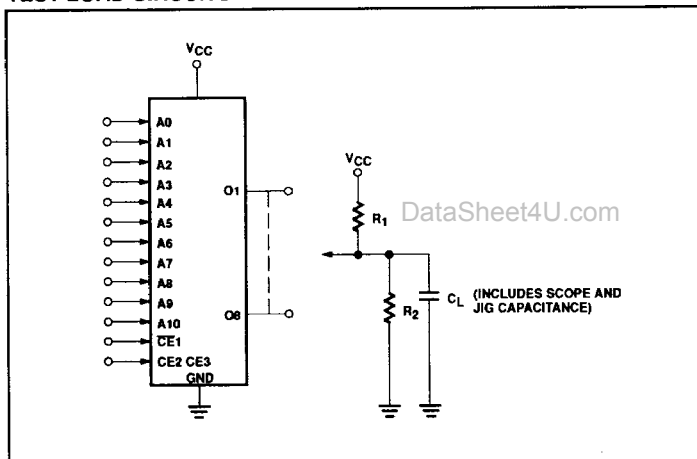

VOLTAGE WAVEFORMS

