

To : _____

Specification of FUJITSU TFT-LCD module

NA19026-C081

Approval
Date :
By :

This Product is designed, developed and manufactured as contemplated for general use, including without limitation, general office use, personal use, household use, and ordinary industrial use, but is not designed, developed and manufactured as contemplated for use accompanying fatal risks or dangers that, unless extremely high safety is secured, could lead directly to death, personal injury, severe physical damage or other loss (hereinafter "High Safety Required Use"), including without limitation, nuclear reaction control in nuclear facility, aircraft flight control, air traffic control, mass transport control, medical life support system, missile launch control in weapon system. If customer's product possibly falls under the category of High Safety Required Use, please consult with our sales representatives in charge before such use. In addition, FDTC shall not be liable against the customer and/or any third party for any claims or damages arising in connection with the High Safety Required Use of the Product without permission.

Specification No. : Tech Bes LCD-00223

Issue Date : Oct. 15, 2003

Issued by :

F. Yamada

F. Yamada

Director

Design Dept.

LCD Products Div.

FUJITSU DISPLAY TECHNOLOGIES CORPORATION

【NA19026-C081】

TABLE OF CONTENTS

A	1.APPLICATIONS.....	2
	2.PRODUCT NAME AND MODEL NAME	
	2-1.Product Name	2
	2-2.Model Name	2
	3.OVERVIEW	2
	4.CONFIGURATION.....	2
B	5.MECHANICAL SPECIFICATIONS	3
	6.ABSOLUTE MAXIMUM RATINGS	4
	7.RECOMMENDED OPERATING CONDITIONS.....	4
	8.ELECTRICAL SPECIFICATIONS	5
	9.OPTICAL SPECIFICATIONS.....	7
	10.INTERFACE SPECIFICATIONS	
	10-1.Signal descriptions	11
	10-2.Color Data Assignment	14
C	10-3.Input Signal Timing	15
	10-4.Correspondence between Data and Display Position	17
	10-5.Power Supply Sequence	17
	11.BACKLIGHT SPECIFICATIONS	
	11-1.Pin Configuration for Backlight.....	18
	11-2.CCFL	18
	11-3.Life.....	18
	11-4.Lamp Assembly Set (for Replacement)	18
D	12.APPEARANCE SPECIFICATIONS	19
	13.ENVIRONMENTAL SPECIFICATIONS	20
	14.INDICATIONS	21
	15.PACKAGING	21
	16.PRECAUTIONS	26
	17.PRECAUTIONS FOR USE.....	29
	18.MISCELLANEOUS.....	29

DOCUMENT CONTROL SECTION

DATE

						NA19026-C081		
						Tech Bes LCD-00223		CUST.
02	20031015	SEKIDO	TAKAHASHI	YAMADA	add P19			
EDIT	DATE	DESIG.	CHECK	APPR.	DESCRIPTION	FUJITSU DISPLAY TECHNOLOGIES CORPORATION		1 /
DESIG.	20030926	Sekido	CHECK	Takahashi	APPR.	Yamada		

【NA19026-C081】

1. APPLICATIONS

This specification is applied to the 17.0 in. XGA-WIDE supported TFT-LCD module.

2. PRODUCT NAME AND MODEL NAME

2-1. Product Name : LCD Module

2-2. Model Name : NA19026-C081

3. OVERVIEW

This LCD module has a TFT active matrix type liquid crystal panel 1280×768 pixels, and diagonal size of 43cm (17.0-inch). This module supports 1280×768 XGA-WIDE mode (Non-interlace).

This LCD has a XGA-WIDE-capable 1ch-LVDS interface and can display 16 million colors. By timing control signal, images are displayed on the screen at given value under specified timing.

Control signals to this LCD module are ENAB (Data enable signal), DCLK signal and RGB data signal. Data signal is transmitted with single port. (8 bit for each R, G, B)

The power supply of this LCD module is +5V DC.

4. CONFIGURATION

This LCD module consists of a color TFT-LCD panel that mounted with TFT driver ICs, a cold-cathode fluorescent tube back-light, a LVDS interface PCB, a structure and a bezel. And these components are integrated in a LCD module.

Cold-cathode fluorescent tube and lamp holder are replaceable.

Fig.4-1 shows a block diagram of this LCD module.

DOCUMENT CONTROL SECTION
DATE

						NA19026-C081		
						Tech Bes LCD-00223		CUST.
EDIT	DATE	DESIG.	CHECK	APPR.	DESCRIPTION		FUJITSU DISPLAY TECHNOLOGIES CORPORATION	
DESIG.			CHECK		APPR.		2 /	

【NA19026-C081】

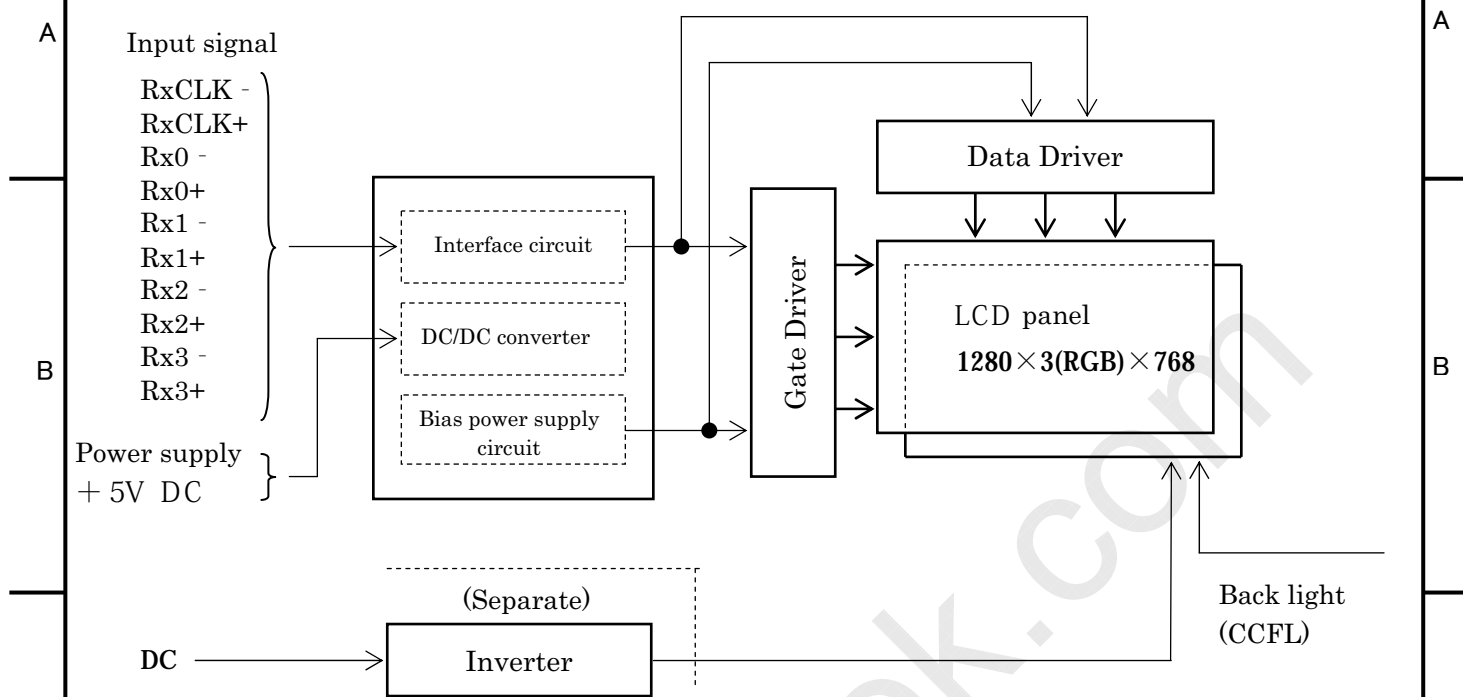

Figure 4-1. Block Diagram

5. MECHANICAL SPECIFICATIONS

Table 5-1 shows the mechanical specifications of this LCD module.

Table 5-1. Mechanical Specifications

Item	Specifications	Unit	Remark
Dimensions	413.8×263.5×18.4(TYP.)	mm	Edge type backlight is used. (φ2.6 CCFL×4) Outward Appearance is shown at page 32 and 33.
Display Resolution	(1280×3) ×768	—	
Display Dot Area	369.6×221.76	mm	
Dot Pitch	(0.09625×3) ×0.28875	mm	
Aspect Ratio	1 : 1	—	
Weight	2,000 max	g	
FG-SG	Short circuit	—	

DOCUMENT CONTROL SECTION

						NA19026-C081	
						Tech Bes LCD-00223	
						CUST.	
EDIT	DATE	DESIG.	CHECK	APPR.	DESCRIPTION	FUJITSU DISPLAY TECHNOLOGIES CORPORATION	
						3 /	

【NA19026-C081】

6. ABSOLUTE MAXIMUM RATINGS

Table 6-1 shows the absolute maximum rating of this LCD module.

Table 6-1. Absolute Maximum Ratings

Item	Symbol	MIN.	TYP.	MAX.	Unit
Supply Voltage	V _{CC}	-0.3	—	6.0	V
Input Voltage	V _{IN}	-0.3	—	V _{CC} +0.3	V

7. RECOMMENDED OPERATING CONDITIONS

Table 7-1 shows the recommended operating conditions of this LCD module.

Table 7-1. Recommended Operating Conditions

Item	Symbol	MIN.	TYP.	MAX.	Unit
Supply Voltage	V _{CC}	4.75	5.0	5.25	V
Ripple Voltage (V _{CC})	V _{RP}	—	—	100	mVp-p

DOCUMENT CONTROL SECTION

						NA19026-C081	
						Tech Bes LCD-00223	
						CUST.	
EDIT	DATE	DESIG.	CHECK	APPR.	DESCRIPTION	FUJITSU DISPLAY TECHNOLOGIES CORPORATION	
DESIG.			CHECK		APPR.	4 /	

【NA19026-C081】

8. ELECTRICAL SPECIFICATIONS

Table 8-1 shows the electrical specifications of this LCD module.

Table 8-1. Electrical Specifications

Item	Symbol	Condition	MIN.	TYP.	MAX.	Unit	Remark
Supply Current	I _{CC}	V _{CC} =+5.0±0.25V V _{SS} =0V	—	680	900	mA	*1
“H” Level Logic Input Voltage	V _{IH}	DCLK=32.498MHz	0.7× V _{CC}	—	V _{CC} + 0.3	V	*2
“L” Level Logic Input Voltage	V _{IL}		GND	—	0.3× V _{CC}	V	*2
CCFL Turn on Voltage	V _S	f _L =50kHz, T _a =25°C	—	1230	1600	V _{rms}	
		f _L =50kHz, T _a =0°C	—	—	1600		
Lighting Voltage	V _L	f _L =50kHz I _L =10.5mA	590	630	670	V _{rms}	*4
Lighting Frequency	f	V _L =630V _{rms}	40	50	60	kHz	
Tube Current	I	f _L =50kHz V _L =630V _{rms}	9.5	10.5	11.0	mArms	*4

(*1) Typical current value is measured when gray scale (vertical 256 levels) is displayed at V_{CC}=5.0V.

Maximum current value is measured when stripes with respect to each RGB dot are displayed at V_{CC}=5.0V.

Without rush current.

(*2) Timing control circuit input voltage

(*3) Backlight specifications are valid when using a suitable inverter such as the “FLCV-15” of FDTC.

(*4) Tube current (I_L) shows the value of the current and voltage that is consumed at one lamp. (4 tubes/unit)

This LCD module has 4 lamps. Each 2 lamps are placed at upper and lower side of the display.

2 lamps are connected in parallel. Each low voltage terminals (GND side) are bound into 1 line cable.

(See 11-1. Pin configuration for backlight)

DOCUMENT CONTROL SECTION

DATE

						NA19026-C081	
						Tech Bes LCD-00223	
						CUST.	
EDIT	DATE	DESIG.	CHECK	APPR.	DESCRIPTION		FUJITSU DISPLAY TECHNOLOGIES CORPORATION
DESIG.			CHECK		APPR.		5 /

【NA19026-C081】

Note 1) Measurement Circuit

Based on Fig.8-1.

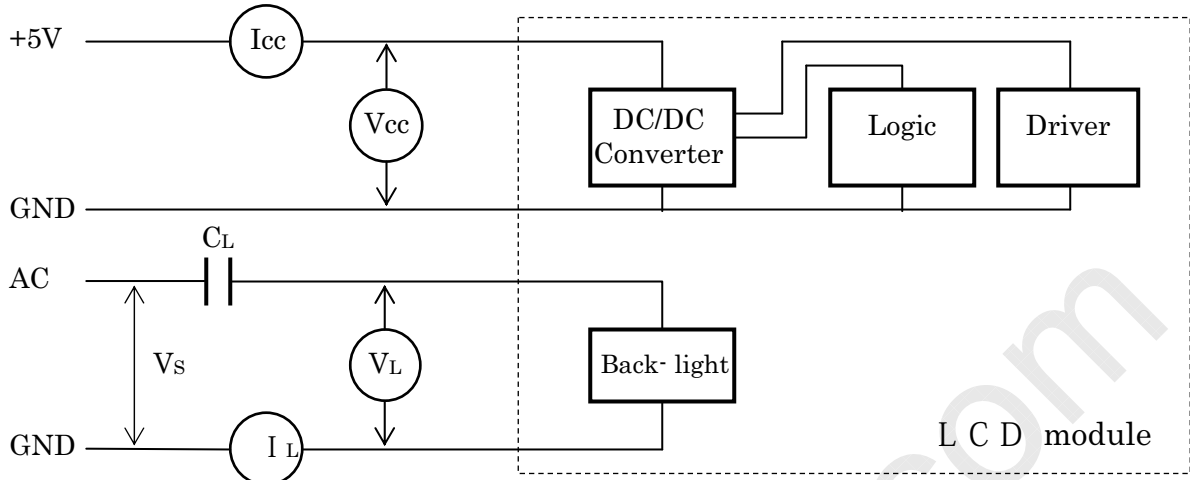

Fig.8-1. Measurement Circuit

Note 2) Equivalent Circuit

Based on Fig.8-2 (a), (b).

Input signals(LVDS-1ch)

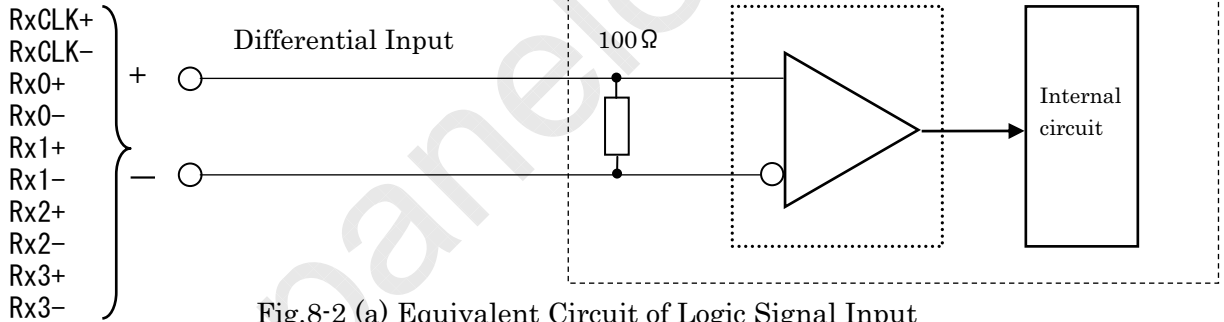

Fig.8-2 (a) Equivalent Circuit of Logic Signal Input

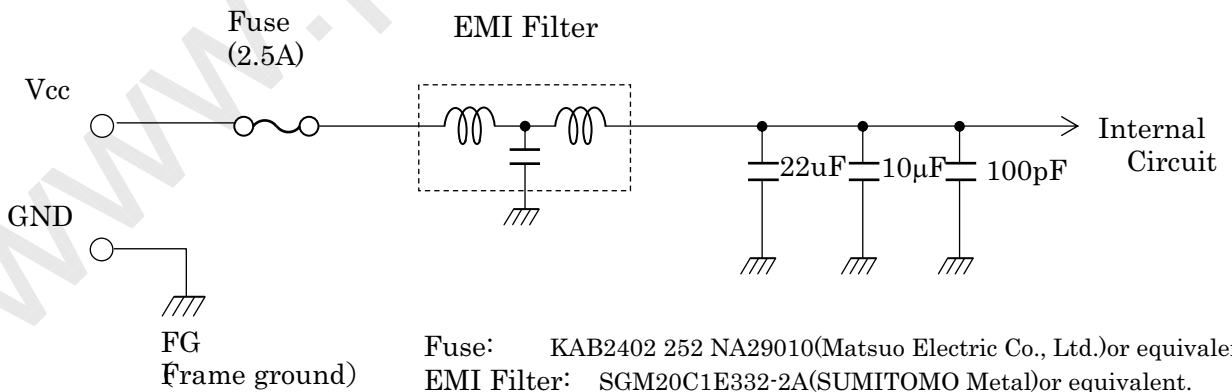

Fig.8-2 (b) Equivalent Circuit of Power Supply

DOCUMENT CONTROL SECTION

DATE

						NA19026-C081	
						Tech Bes LCD-00223	
						CUST.	
EDIT	DATE	DESIG.	CHECK	APPR.	DESCRIPTION	FUJITSU DISPLAY TECHNOLOGIES CORPORATION	
DESIG.			CHECK		APPR.	6 /	

【NA19026-C081】

9. OPTICAL SPECIFICATIONS

Table 9-1 shows the optical specifications of this LCD module.

Table 9-1. Optical Specifications

Ta=25°C

Item	Symbol	Condition	Specifications			Unit	Remark			
			MIN.	TYP.	MAX.		Note			
Visual Angle	Horizontal	$\theta_{L,R}$	CR \geq 10	$\theta_{U,D}=0^\circ$	85	—	—	deg	(1)(2)	
	Vertical	$\theta_{U,D}$		$\theta_{L,R}=0^\circ$	85	—	—	deg	(3)(5)(6)	
Contrast Ratio	CR	$\theta_{L,R,U,D}=0^\circ$			350	600	—	—	White/Black (1)(2)(3)(5)	
Response Time(ON) (B→W)	t_{on}	$\theta_{L,R,U,D}=0^\circ$	Ta=25°C		—	15	30	ms	(1)(4)	
			Ta=0°C		—	50	100	ms	(5)	
Response Time(OFF) (W→B)	t_{off}	$\theta_{L,R,U,D}=0^\circ$	Ta=25°C		—	10	25	ms		
			Ta=0°C		—	50	100	ms		
Brightness	I	$\theta_{L,R,U,D}=0^\circ$ V _{CC} =5V, I _L =10.5mA (at maximum brightness)			350	450	—	cd/m ²	White *1 (1)(5)	
Brightness Uniformity	ΔI				75	—	—	%	(1)(5)(7)	
Chromaticity	W		X			0.283	0.313	0.343	—	(1)(5)
			Y			0.299	0.329	0.359	—	
	R G B		(x, y)	Red	0.65, 0.34 Typ.					
			Green	0.30, 0.59 Typ.						
			Blue	0.15, 0.14 Typ.						
γ -curve	γ				2.4 Typ.					
LCD Panel Type					TFT Color					
Display Mode					Normally Black VA					
Wide Viewing Angle Technology					MVA-Premium					
Optimum Viewing Angle					— (symmetry)				(6)	
Display Color					16 million (each 6-bit+2-bit FRC)					
Color of non-display area					Black					
Surface Treatment					—					

(*1) Specified value is measured in 20~30 minutes after lighting on (LCD module single).
 A required value may not be achieved on condition that LCD module is built in the cabinet because of its radiation.
 All items without “Brightness Uniformity” are measured at the center of display board.

(Note1) • CS-1000 (MINOLTA Co., Ltd.) , BM-5A(Topcon) or equivalent luminance colorimeter should be used for the measurement.
 Field=2°, L=500mm
 •The specified value of viewing angle, contrast, brightness, brightness uniformity and chromaticity are under the dark room condition (1lux or less).

DOCUMENT CONTROL SECTION

DATE

					NA19026-C081				
					Tech Bes LCD-00223				
					CUST.				
EDIT	DATE	DESIG.	CHECK	APPR.	DESCRIPTION				
					FUJITSU DISPLAY TECHNOLOGIES CORPORATION				
					7 /				

Note 1) Definition of Viewing Angle (1)

Based on Fig.9-2.

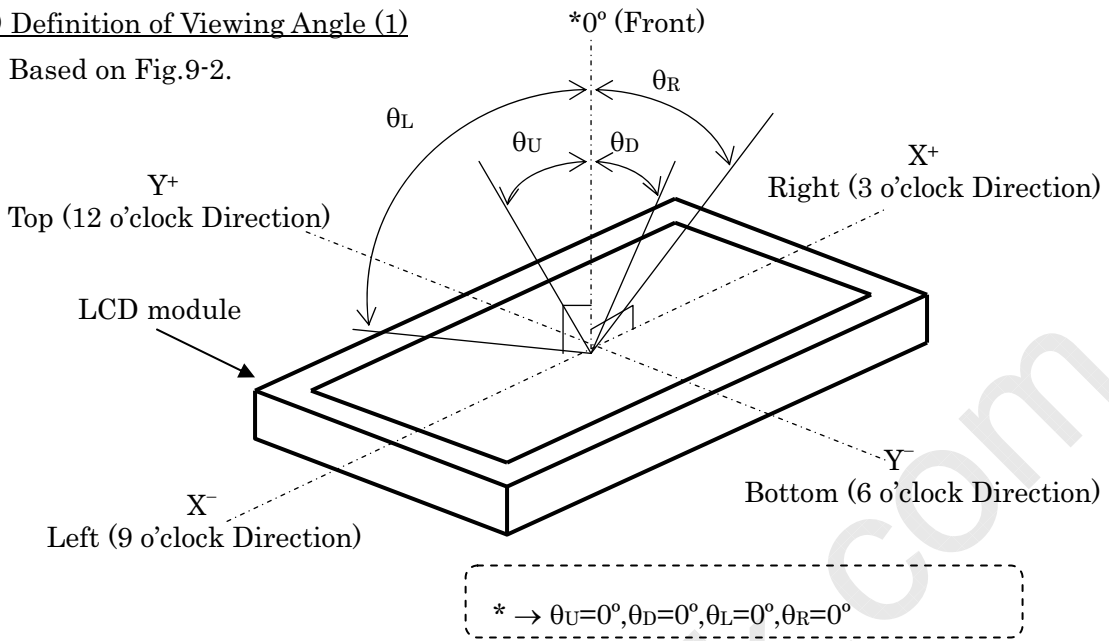

Fig.9-2. Definition of Viewing Angle (1)

Note 2) Definition of Viewing Angle (2)

Based on Fig.9-3.

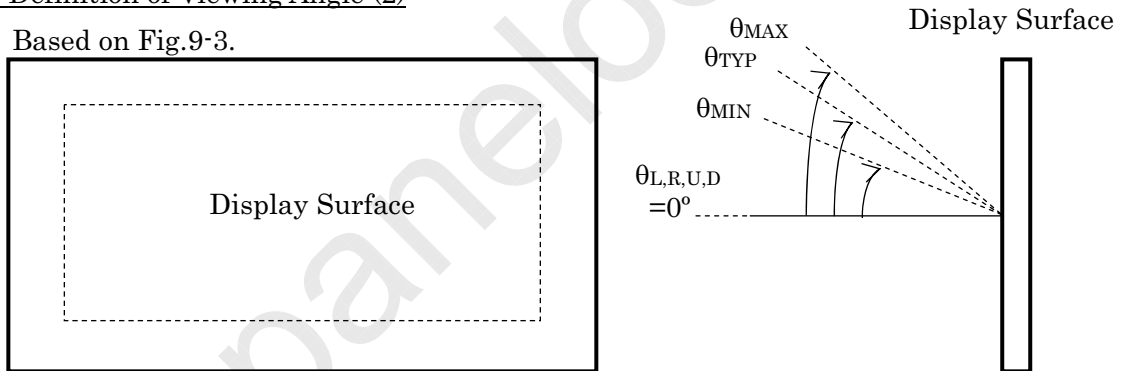

Fig.9-3. Definition of Viewing Angle (2)

Note 3) Definition of Contrast Ratio (CR)

Determined by Formula (1) based on Fig.9-4. Voltage-Brightness Characteristics.

$$= \frac{L_W \text{ (Brightness at white)}}{L_B \text{ (Brightness at black)}} \quad \text{----- (1)}$$

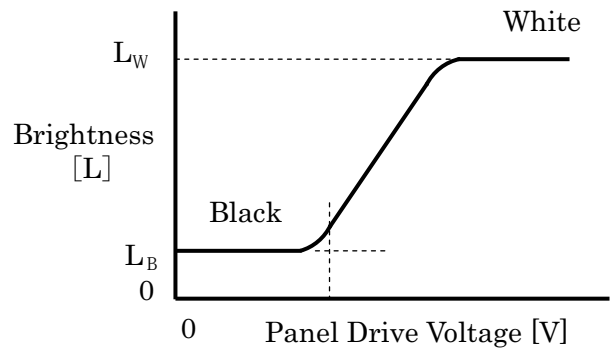

Fig.9-4. Voltage-Brightness Characteristics

DOCUMENT CONTROL SECTION
DATE

						NA19026-C081	
						Tech Bes LCD-00223	
						CUST.	
EDIT	DATE	DESIG.	CHECK	APPR.	DESCRIPTION	FUJITSU DISPLAY TECHNOLOGIES CORPORATION	
DESIG.			CHECK		APPR.	8 /	

Note 4) Definition of Response Time

Based on Fig.9-5.

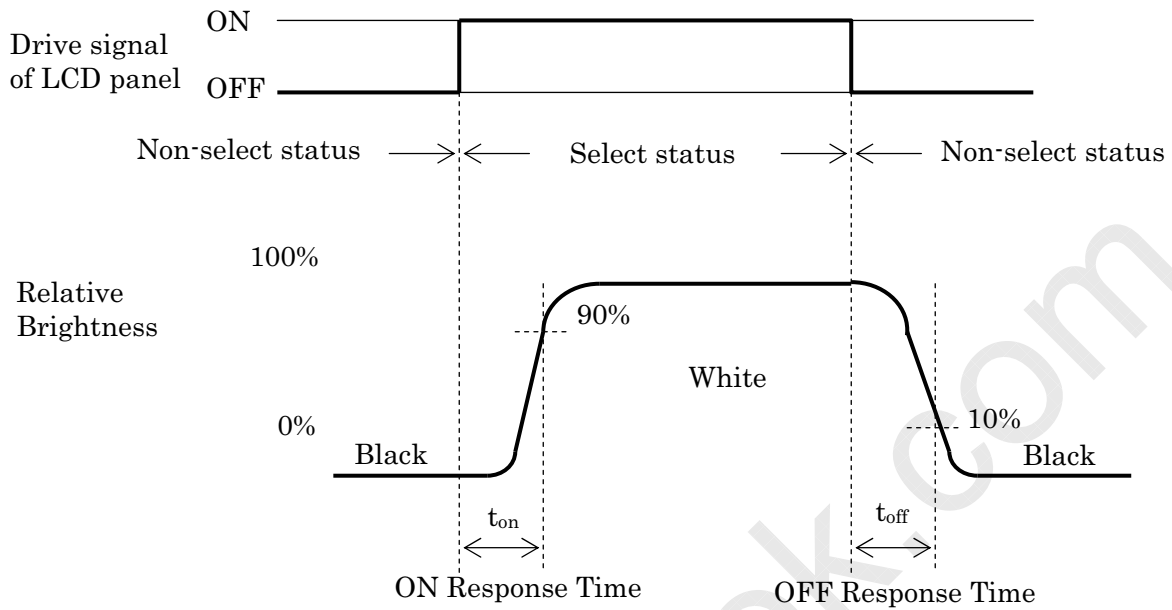

Fig.9-5. Definition of Response Time

Note 5) Contrast Ratio and Response Measurement System

Based on Fig.9-6.

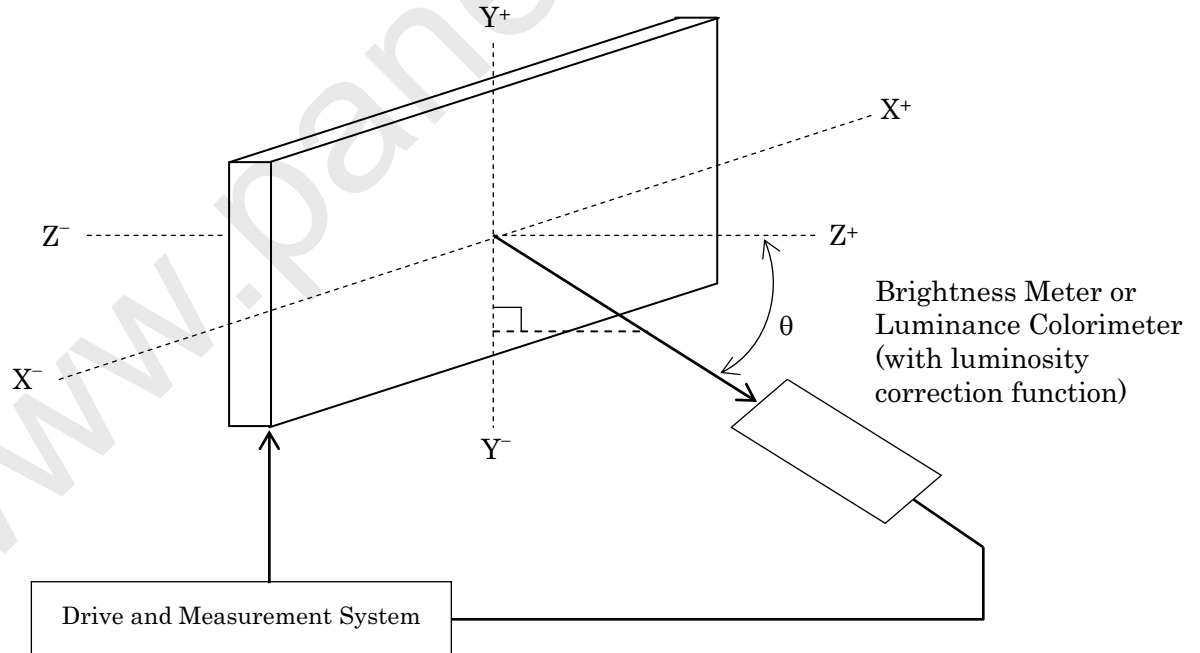

Fig.9-6. Contrast Ratio and Response Time Measurement System

DOCUMENT CONTROL SECTION
DATE

						NA19026-C081	
						Tech Bes LCD-00223	
						CUST.	
EDIT	DATE	DESIG.	CHECK	APPR.	DESCRIPTION	FUJITSU DISPLAY TECHNOLOGIES CORPORATION	9 /
DESIG.			CHECK		APPR.		

Note 6) Definition of Optimum Viewing Angle

Based on Fig.9-7.

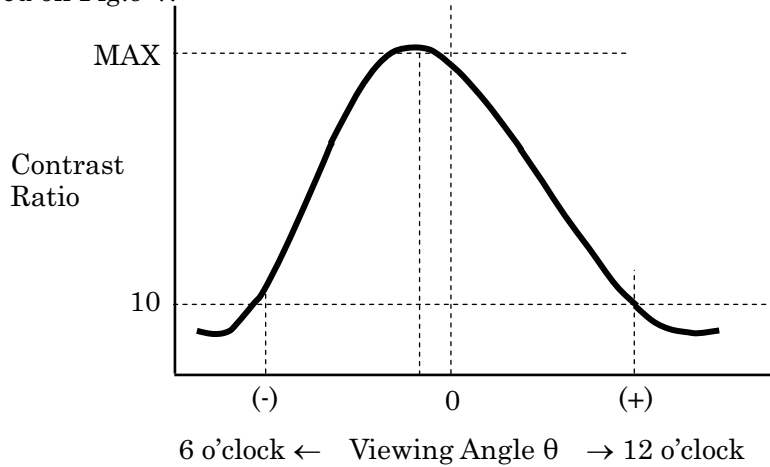

Fig.9-7. Definition of Viewing Angle

Note 7) Definition of Brightness Uniformity

Brightness uniformity is defined by the following formula.

Brightness (I1~I9) are measured at the following 9 points (① ~ ⑨) on the display area shown in Fig.9-8.

$$\text{Brightness Uniformity } (\Delta L) = \frac{|\text{Min. In}|}{|\text{Max. In}|} \times 100 (\%), n=1 \text{ to } 9$$

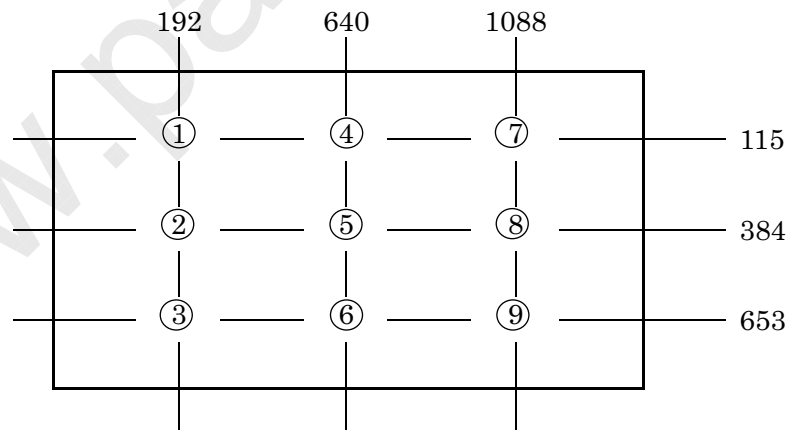

Note) Each measurement point (① ~ ⑨) defines the center spot of Brightness Meter view. The tolerance of measurement position is $\pm 3\text{mm}$.

Fig.9-8. Measurement Points

DOCUMENT CONTROL SECTION

DATE

						NA19026-C081	
						Tech Bes LCD-00223	
						CUST.	
EDIT	DATE	DESIG.	CHECK	APPR.	DESCRIPTION	FUJITSU DISPLAY TECHNOLOGIES CORPORATION	
DESIG.			CHECK		APPR.	10/	

10. INTERFACE SPECIFICATIONS

10-1-1. Signal descriptions

Table 10-1 shows the description and configuration of Interface signals (CN1).

Table 10-1-1. Interface signals (CN1)

Pin No.	Symbol	I/O	Function
1	VDD	—	+5V Power suply
2	VDD	—	+5V Power suply
3	GND	—	Ground
4	GND	—	Ground
5	RX0-	I	LVDS Receiver Signal(-)
6	RX0+	I	LVDS Receiver Signal(+)
7	GND	—	Ground
8	RX1-	I	LVDS Receiver Signal(-)
9	RX1+	I	LVDS Receiver Signal(+)
10	GND	—	Ground
11	RX2-	I	LVDS Receiver Signal(-)
12	RX2+	I	LVDS Receiver Signal(+)
13	GND	—	Ground
14	RXCLK-	I	LVDS Receiver Clock Signal(-)
15	RXCLK+	I	LVDS Receiver Clock Signal(+)
16	GND	—	Ground
17	RX3-	I	LVDS Receiver Signal(-)
18	RX3+	I	LVDS Receiver Signal(+)
19	GND	—	Ground
20	Data Mapping Select Input	I	Low : table 10-1-2 Open or Hi : table 10-1-3

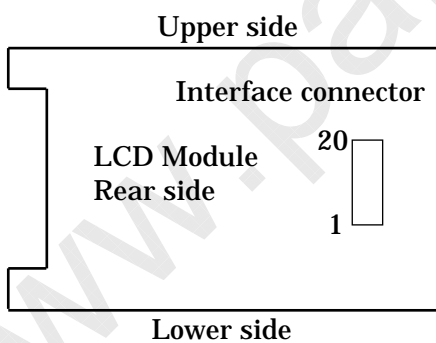

Connector : D14H-20P-1.25H(HIROSE)

User's connector : DF14-20S-1.25 (HIROSE)

Note)When using a interface connector other than the recommended one, a defect in the initial stage or a problem concerning long term reliabiling may occur.

DOCUMENT CONTROL SECTION

DATE

						NA19026-C081	
						Tech Bes LCD-00223	
						CUST.	
EDIT	DATE	DESIG.	CHECK	APPR.	DESCRIPTION	FUJITSU DISPLAY TECHNOLOGIES CORPORATION	
DESIG.			CHECK		APPR.	11 /	

【NA19026-C081】

10-1-2. LVDS Data Mapping 1

Table 10-1-2 shows the LVDS data mapping 1.(DataMappingSelectInput = Low)

Table 10-1-2. LVDS Data Mapping 1

Transmitter (DS90CF385)		Symbol	Interface connector			Receiver (DS90CF386)		LCD Control input
Pin	INPUT		System side	Pin	LCD module	Pin	OUTPUT	
51	TxIN0	R0	TxOUT0- TxOUT0+	5 6	RX0- RX0+	27	RxOUT0	IR0
52	TxIN1	R1				29	RxOUT1	IR1
54	TxIN2	R2				30	RxOUT2	IR2
55	TxIN3	R3				32	RxOUT3	IR3
56	TxIN4	R4				33	RxOUT4	IR4
2	TxIN5	R7	TxOUT3- TxOUT3+	17 18	RX3- RX3+	34	RxOUT5	IR7
3	TxIN6	R5	TxOUT0- TxOUT0+	5 6	RX0- RX0+	35	RxOUT6	IR5
4	TxIN7	G0				37	RxOUT7	IG0
6	TxIN8	G1	TxOUT1- TxOUT1+	8 9	RX1- RX1+	38	RxOUT8	IG1
7	TxIN9	G2	39			RxOUT9	IG2	
8	TxIN10	G6	TxOUT3- TxOUT3+	17 18	RX3- RX3+	41	RxOUT10	IG6
10	TxIN11	G7				42	RxOUT11	IG7
11	TxIN12	G3	TxOUT1- TxOUT1+	8 9	RX1- RX1+	43	RxOUT12	IG3
12	TxIN13	G4				45	RxOUT13	IG4
14	TxIN14	G5				46	RxOUT14	IG5
15	TxIN15	B0	TxOUT3- TxOUT3+	17 18	RX3- RX3+	47	RxOUT15	IB0
16	TxIN16	B6				49	RxOUT16	IB6
18	TxIN17	B7	50	RxOUT17	IB7			
19	TxIN18	B1	TxOUT1- TxOUT1+	8 9	RX1- RX1+	51	RxOUT18	IB1
20	TxIN19	B2	TxOUT2- TxOUT2+	11 12	RX2- RX2+	53	RxOUT19	IB2
22	TxIN20	B3				54	RxOUT20	IB3
23	TxIN21	B4				55	RxOUT21	IB4
24	TxIN22	B5				1	RxOUT22	IB5
25	TxIN23	RESERVED	TxOUT3- TxOUT3+	17 18	RX3- RX3+	2	RxOUT23	Not use
27	TxIN24	RESERVED	TxOUT2- TxOUT2+	11 12	RX2- RX2+	3	RxOUT24	Not use
28	TxIN25	RESERVED				5	RxOUT25	Not use
30	TxIN26	ENAB				6	RxOUT26	ENAB
50	TxIN27	R6	TxOUT3- TxOUT3+	17 18	RX3- RX3+	7	RxOUT27	IR6
31	TxCLKIN	DCLK	TxCLKOUT-	14	RXCLK-	26	RxCLKOUT	DCLK
			TxCLKOUT+	15	RXCLK+			

DOCUMENT CONTROL SECTION

DATE

						NA19026-C081	
						Tech Bes LCD-00223	
						CUST.	
EDIT	DATE	DESIG.	CHECK	APPR.	DESCRIPTION	FUJITSU DISPLAY TECHNOLOGIES CORPORATION	
DESIG.			CHECK	APPR.		12/	

【NA19026-C081】

10-1-3. LVDS Data Mapping 2

Table 10-1-3 shows the LVDS data mapping 2.(DataMappingSelectInput = Open or Hi)

Table 10-1-3. LVDS Data Mapping 2

Transmitter (DS90CF385)		Symbol	Interface connector			Receiver (DS90CF386)		LCD Control input
Pin	INPUT		System side	Pin	LCD module	Pin	OUTPUT	
51	TxIN0	R2	TxOUT0- TxOUT0+	5 6	RX0- RX0+	27	RxOUT0	IR2
52	TxIN1	R3				29	RxOUT1	IR3
54	TxIN2	R4				30	RxOUT2	IR4
55	TxIN3	R5				32	RxOUT3	IR5
56	TxIN4	R6				33	RxOUT4	IR6
2	TxIN5	R1	TxOUT3- TxOUT3+	17 18	RX3- RX3+	34	RxOUT5	IR1
3	TxIN6	R7	TxOUT0- TxOUT0+	5 6	RX0- RX0+	35	RxOUT6	IR7
4	TxIN7	G2				37	RxOUT7	IG2
6	TxIN8	G3	TxOUT1- TxOUT1+	8 9	RX1- RX1+	38	RxOUT8	IG3
7	TxIN9	G4				39	RxOUT9	IG4
8	TxIN10	G0	TxOUT3- TxOUT3+	17 18	RX3- RX3+	41	RxOUT10	IG0
10	TxIN11	G1				42	RxOUT11	IG1
11	TxIN12	G5	TxOUT1- TxOUT1+	8 9	RX1- RX1+	43	RxOUT12	IG5
12	TxIN13	G6				45	RxOUT13	IG6
14	TxIN14	G7				46	RxOUT14	IG7
15	TxIN15	B2				47	RxOUT15	IB2
16	TxIN16	B0	TxOUT3- TxOUT3+	17 18	RX3- RX3+	49	RxOUT16	IB0
18	TxIN17	B1				50	RxOUT17	IB1
19	TxIN18	B3	TxOUT1- TxOUT1+	8 9	RX1- RX1+	51	RxOUT18	IB3
20	TxIN19	B4	TxOUT2- TxOUT2+	11 12	RX2- RX2+	53	RxOUT19	IB4
22	TxIN20	B5				54	RxOUT20	IB5
23	TxIN21	B6				55	RxOUT21	IB6
24	TxIN22	B7				1	RxOUT22	IB7
25	TxIN23	RESERVED	TxOUT3- TxOUT3+	17 18	RX3- RX3+	2	RxOUT23	Not use
27	TxIN24	RESERVED	TxOUT2- TxOUT2+	11 12	RX2- RX2+	3	RxOUT24	Not use
28	TxIN25	RESERVED				5	RxOUT25	Not use
30	TxIN26	ENAB				6	RxOUT26	ENAB
50	TxIN27	RO	TxOUT3- TxOUT3+	17 18	RX3- RX3+	7	RxOUT27	IRO
31	TxCLKIN	DCLK	TxCLKOUT- TxCLKOUT+	14 15	RXCLK- RXCLK+	26	RxCLKOUT	DCLK

DOCUMENT CONTROL SECTION

DATE

						NA19026-C081		
						Tech Bes LCD-00223		CUST.
EDIT	DATE	DESIG.	CHECK	APPR.	DESCRIPTION	FUJITSU DISPLAY TECHNOLOGIES CORPORATION		13/
DESIG.			CHECK	APPR.				

【NA19026-C081】

10-2. Color Data Assignment

Table 10-2 shows the color data assignment.

Table 10-2. Color Data Assignment

Color and Brightness		Input data (0 : Low level, 1 : High level)																							
		R7	R6	R5	R4	R3	R2	R1	R0	G7	G6	G5	G4	G3	G2	G1	G0	B7	B6	B5	B4	B3	B2	B1	B0
Basic Color	Black	0	0	0	0	0	0	0	0	0	0	0	0	0	0	0	0	0	0	0	0	0	0	0	0
	Blue	0	0	0	0	0	0	0	0	0	0	0	0	0	0	0	0	1	1	1	1	1	1	1	1
	Green	0	0	0	0	0	0	0	0	0	1	1	1	1	1	1	1	0	0	0	0	0	0	0	0
	Cyan	0	0	0	0	0	0	0	0	0	1	1	1	1	1	1	1	1	1	1	1	1	1	1	1
	Red	1	1	1	1	1	1	1	1	1	0	0	0	0	0	0	0	0	0	0	0	0	0	0	0
	Magenta	1	1	1	1	1	1	1	1	1	0	0	0	0	0	0	0	0	1	1	1	1	1	1	1
	Yellow	1	1	1	1	1	1	1	1	1	1	1	1	1	1	1	1	0	0	0	0	0	0	0	0
	White	1	1	1	1	1	1	1	1	1	1	1	1	1	1	1	1	1	1	1	1	1	1	1	1
Red	Black	0	0	0	0	0	0	0	0	0	0	0	0	0	0	0	0	0	0	0	0	0	0	0	
	↑	1	0	0	0	0	0	0	0	0	0	0	0	0	0	0	0	0	0	0	0	0	0	0	
	Darker	2	0	0	0	0	0	0	1	0	0	0	0	0	0	0	0	0	0	0	0	0	0	0	
	↑	...	:	:	:	:	:	:	:	:	:	:	:	:	:	:	:	:	:	:	:	:	:	:	
	↓	...	:	:	:	:	:	:	:	:	:	:	:	:	:	:	:	:	:	:	:	:	:	:	
	Brighter	253	:	:	:	:	:	:	:	:	:	:	:	:	:	:	:	:	:	:	:	:	:	:	
	↓	254	1	1	1	1	1	1	0	1	0	0	0	0	0	0	0	0	0	0	0	0	0	0	
Red	255	1	1	1	1	1	1	1	0	0	0	0	0	0	0	0	0	0	0	0	0	0	0		
Green	Black	0	0	0	0	0	0	0	0	0	0	0	0	0	0	0	0	0	0	0	0	0	0	0	
	↑	1	0	0	0	0	0	0	0	0	0	0	0	0	0	0	1	0	0	0	0	0	0	0	
	Darker	2	0	0	0	0	0	0	0	0	0	0	0	0	0	0	0	0	0	0	0	0	0	0	
	↑	...	:	:	:	:	:	:	:	:	:	:	:	:	:	:	:	:	:	:	:	:	:	:	
	↓	...	:	:	:	:	:	:	:	:	:	:	:	:	:	:	:	:	:	:	:	:	:	:	
	Brighter	253	:	:	:	:	:	:	:	:	:	:	:	:	:	:	:	:	:	:	:	:	:	:	
	↓	254	0	0	0	0	0	0	0	0	1	1	1	1	1	1	0	1	0	0	0	0	0	0	
Green	255	0	0	0	0	0	0	0	0	1	1	1	1	1	1	1	0	0	0	0	0	0	0		
Blue	Black	0	0	0	0	0	0	0	0	0	0	0	0	0	0	0	0	0	0	0	0	0	0	0	
	↑	1	0	0	0	0	0	0	0	0	0	0	0	0	0	0	0	0	0	0	0	0	0	1	
	Darker	2	0	0	0	0	0	0	0	0	0	0	0	0	0	0	0	0	0	0	0	0	0	1	
	↑	...	:	:	:	:	:	:	:	:	:	:	:	:	:	:	:	:	:	:	:	:	:	:	
	↓	...	:	:	:	:	:	:	:	:	:	:	:	:	:	:	:	:	:	:	:	:	:	:	
	Brighter	253	:	:	:	:	:	:	:	:	:	:	:	:	:	:	:	:	:	:	:	:	:	:	
	↓	254	0	0	0	0	0	0	0	0	0	0	0	0	0	0	0	0	1	1	1	1	1	0	1
Blue	255	0	0	0	0	0	0	0	0	0	0	0	0	0	0	0	0	1	1	1	1	1	1	0	
		0	0	0	0	0	0	0	0	0	0	0	0	0	0	0	0	1	1	1	1	1	1	1	

Note.1) Definition of gray scale : Color (n) ---"n" indicates gray scale level.
The gray scale is brighter as the number is larger.

Note.2) Data; 1: High, 0: Low

Note.3) By inputting 8-bit data signal for each red, green and blue, this module can display 256 gray scale independently for each color.
Therefore, the module is able to display 16 million colors. Color data are 24 lines.

DOCUMENT CONTROL SECTION

DATE

						NA19026-C081						
						Tech Bes LCD-00223						
						CUST.						
EDIT	DATE	DESIG.	CHECK	APPR.	DESCRIPTION	FUJITSU DISPLAY TECHNOLOGIES CORPORATION						14/
DESIG.			CHECK		APPR.							

【NA19026-C081】

10-3. Input Signal Timing

Table 10-3 and Fig.10-3 shows the input signal timing.

Table 10-3. Timing Characteristics (T=0~50°C, Vcc=5±0.25V)

Item		Symbol	Min.	Typ.	Max.	Unit	Remark		
DCLK signal (Clock)	Period	Tc	12.195	15.382	20.000	ns	fc=1/Tc *1		
	Frequency	fc	50.00	65.01	82.00	MHz			
	Duty	Tch/Tc	45	50	55	%			
	High time	TclkH	5.0	—	—	ns			
	Low time	TclkL	5.0	—	—	ns			
	Rise time	Tclkr	—	—	5.0	ns			
	Fall time	Tclkf	—	—	5.0	ns			
DCLK-Data Timing	Setup time	Tset	4	—	—	ns			
	Hold time	Thold	4	—	—	ns			
Data-ENAB timing	Horizontal	Period	Th	1310	1344	1688	DCLK	*2,3	
		Frequency	fh	35.0	48.3	75.0	kHz		
		Display period	Thd	1280	1280	1280	DCLK		
	Vertical	Period	Tv	776	806	806	Th		16.67ms
		Frequency	1/Tv	50	60	75	Hz		WXGA mode
		Display period	Tvd	768	768	768	Th		*2,3
Data-ENAB timing		Tdn	0	0	0	DCLK	*4		

- *1) DCLK signal input must be valid while power supply is applied.
- *2) Display position is specified by the ENAB signal only.
 - Horizontal display position is specified by the rise of ENAB signal. The data which is latched by the falling edge of 1st DCLK right after the rise of ENAB, is displayed on the left edge of the screen.
 - Vertical display position is specified by the rise of ENAB after a “Low” level period equivalent to eight times of horizontal period. The 1st data corresponding to one horizontal line after the rise of ENAB is displayed at the top line of screen.
- *3) If a period of ENAB “High” is less than 1280 DCLK or less than 768 lines, the rest of the screen displays black.
- *4) The display position does not fit to the screen if a period of ENAB “High” and the effective data period do not synchronize with each other.
- *5) The specifications of all are not provided individually.
It is necessary that all of those specifications are satisfied at the same time.
- *6)The display quality is guaranteed by the Typ timing.

DOCUMENT CONTROL SECTION

DATE

						NA19026-C081	
						Tech Bes LCD-00223	
						CUST.	
EDIT	DATE	DESIG.	CHECK	APPR.	DESCRIPTION	FUJITSU DISPLAY TECHNOLOGIES CORPORATION	
DESIG.			CHECK	APPR.		15 /	

【NA19026-C081】

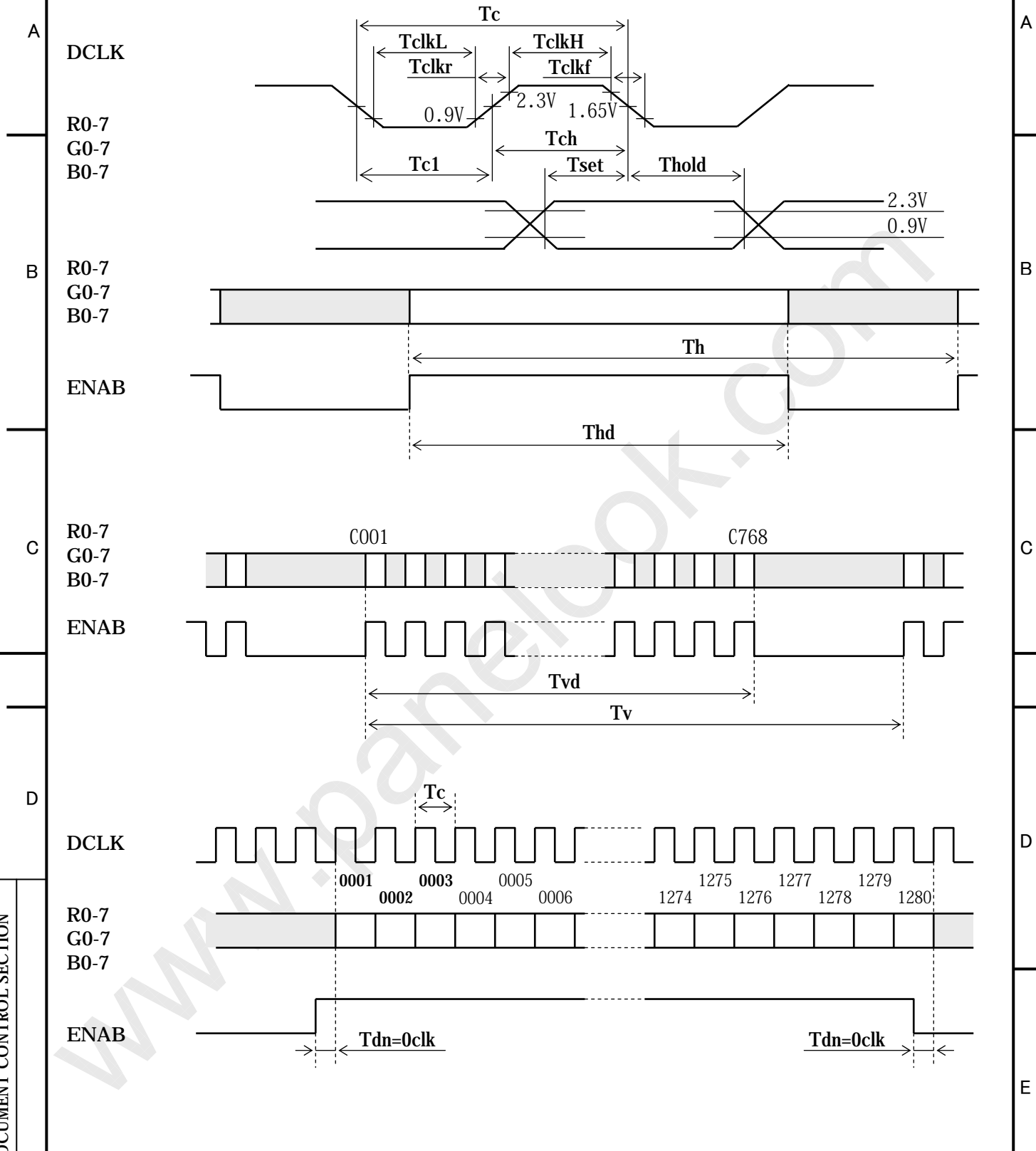

Fig.10-3.Input Signal Timing Chart

DOCUMENT CONTROL SECTION

						NA19026-C081	
						Tech Bes LCD-00223	
						CUST.	
EDIT	DATE	DESIG.	CHECK	APPR.	DESCRIPTION		FUJITSU DISPLAY TECHNOLOGIES CORPORATION
DESIG.			CHECK		APPR.		16/

10-4. Correspondence between Data and Display Position

Fig.10-4 shows the Correspondence between Data and Display Position.

S0001 S0002 S0003 S0004 S0005 S0006 S0007 S0008 ----- S3839 S3840											
C001	R 0001	G 0001	B 0001	R 0002	G 0002	B 0002	R 0003	G 0003		G 1280	B 1280
C768	R 0001	G 0001	B 0001	R 0002	G 0002	B 0002	R 0003	G 0003		G 1280	B 1280

Fig.10-4. Correspondence Data and Display Position

10-5. Power Supply Sequence

The sequence of input signals and On/Off of the power supply of this LCD module should be in the specification shown in Fig.10-5 to prevent latch-up of the driver ICs and DC driving of the LCD panel.

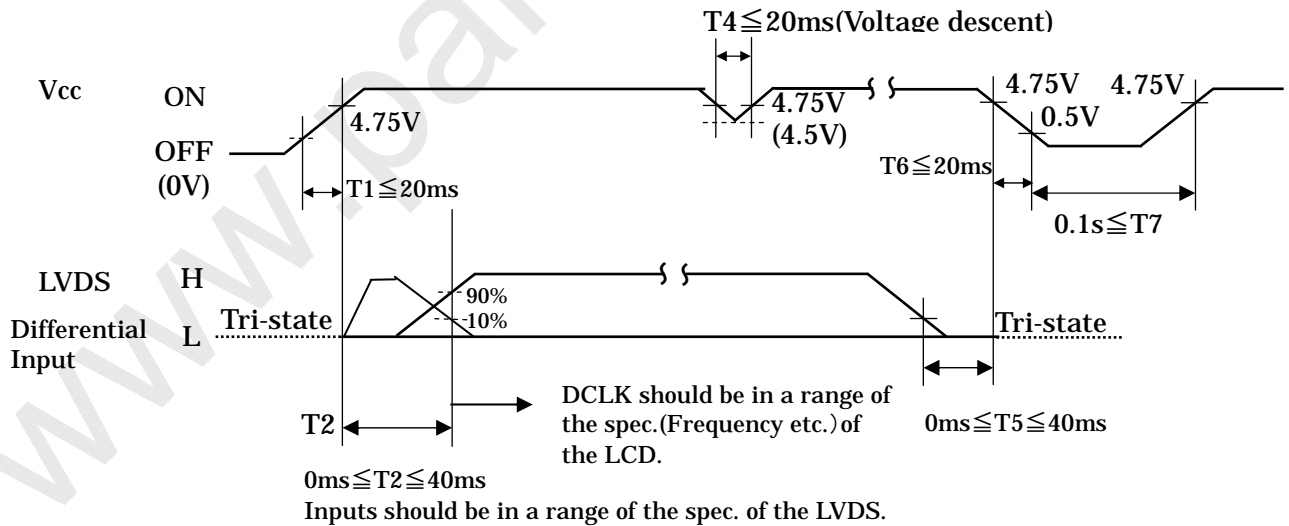

Fig.10-5. Power Supply Sequence

DOCUMENT CONTROL SECTION

DATE

						NA19026-C081	
						Tech Bes LCD-00223	
						CUST.	
EDIT	DATE	DESIG.	CHECK	APPR.	DESCRIPTION	FUJITSU DISPLAY TECHNOLOGIES CORPORATION	
DESIG.			CHECK	APPR.		17/	

【NA19026-C081】

11. BACKLIGHT SPECIFICATIONS

11-1. Pin Configuration for Backlight

Table 11-1(a) and 11-1(b) shows the description and pin assignment of the connectors (CN-A and B) for the Backlight of this LCD module.

Table 11-1(a) Pin Assignment of CN-A

Table 11-1(b) Pin Assignment of CN-B

Pin No.	Signal	Function	Cable color
1	VL1	Power supply for CCFL 1	Red
2	VL2	Power supply for CCFL 2	Red
3	NC	—	—
4	GND	Ground (for VL1, 2)	White

Pin No.	Signal	Function	Cable color
1	VL3	Power supply for CCFL 3	Red
2	VL4	Power supply for CCFL 4	Red
3	NC	—	—
4	GND	Ground (for VL3, 4)	White

Connector : Housing : BHR-04VS-1
 : Contact : SBH-001T-P0.5
 User's Connector : Post with base : SM04(4.0)B-BHS-1-TB
 Supplier : Japan Solderless Terminal Trading Company LTD. (J.S.T.)

11-2. CCFL

Supplier : SANKEN ELECTRIC CO., LTD Part No. SD26E3850E8350B3113000

11-3. Life

The life of the backlight is a minimum of 25,000 hours at the following conditions.

(1) Working conditions

- ① Ambient temperature : 25±5°C
- ② Tube current(I_L) : (10.5mA or less)

(2) Definition of life

- ① Brightness becomes 50% or below 50% of the minimum brightness value shown in Table 9-1.
- ② The lamp cannot be lit by the breakdown voltage of 1600Vrms.
- ③ Lamp is flashing.

11-4. Lamp Assembly set (for replacement)

Lamp Assembly set (with charge) is prepared for maintenance.
 This set consists of an upper lamp assembly and a lower lamp assembly.

Type number : FLCL-21

DOCUMENT CONTROL SECTION

						NA19026-C081	
						Tech Bes LCD-00223	
						CUST.	
EDIT	DATE	DESIG.	CHECK	APPR.	DESCRIPTION	FUJITSU DISPLAY TECHNOLOGIES CORPORATION	
DESIG.			CHECK		APPR.	18/	

【NA19026-C081】

12. APPEARANCE SPECIFICATIONS

12-1 Appearance

No.	Item	Judgment method and standard	
1	Bright spot (high and Low)	≤ 8 dots (Note 1)	
2	Bright spot connection (high and low)	2 dots connection ≤ 2 pair 3 dots connection ≤ 1 pair (Note 1)	
3	Total of bright spot	≤ 8 dots	
4	Dark spot	≤ 10 dots (Note 2)	
5	Dark spot connection	2 dots connection ≤ 3 pair 3 dots connection ≤ 1 pair (Note 2)	
6	Total of dark spot	≤ 10 dots (Note 2)	
7	Total of dot defect	≤ 18 dots	
8	Distance of dot defect	≥ 2 mm	
9	Black / white spot	$D \leq 0.3$	Ignore
		$0.3 < D \leq 0.6$	$N \leq 5$
		$0.6 < D \leq 0.9$	$N \leq 2$ (Distance ≥ 100 mm)
		$0.9 < D$	0
10	Mura	Ignore	

D:Average diameter [mm], W:Width [mm], L:Length [mm], S=(bright spot size)/(dot size)

DOCUMENT CONTROL SECTION

DATE

						NA19026-C081	
						Tech Bes LCD-00223	
						CUST.	
EDIT	DATE	DESIG.	CHECK	APPR.	DESCRIPTION	FUJITSU DISPLAY TECHNOLOGIES CORPORATION	
DESIG.			CHECK		APPR.	19/	

【NA19026-C081】

13. ENVIRONMENTAL SPECIFICATIONS

Table 12-1 shows the environmental specifications.

Table 12-1. Environmental Specifications

Item	Condition		Remark
Temperature	Operation	0~57°C (Note1)	Temperature on surface of LCD panel (display area.)
	Storage	-20~60°C	
Humidity	Operation	20~85%RH	Maximum wet-bulb temperature should not exceed 29°C. No condensation.
	Storage	5~85%RH	
Vibration	Non-operation	10~500Hz, 1 cycle/20minute, 2G, 1.5mm max, 2hour each X, Y and Z directions	For single module without package.(Note2)
Shock	Non-operation	30G, 6ms, 1time each ±X, ±Y and ±Z directions.	

Note1: Temperature on surface of LCD panel should be under 57°C.

Note2: Table 12-2 and Fig. 12-1 show the shock resistance standard when module is packaged.

Table 12-2. Shock Resistance Standard when Module is Packaged

Dropping location	Dropping height	Count
A ~ J	60cm	1 time

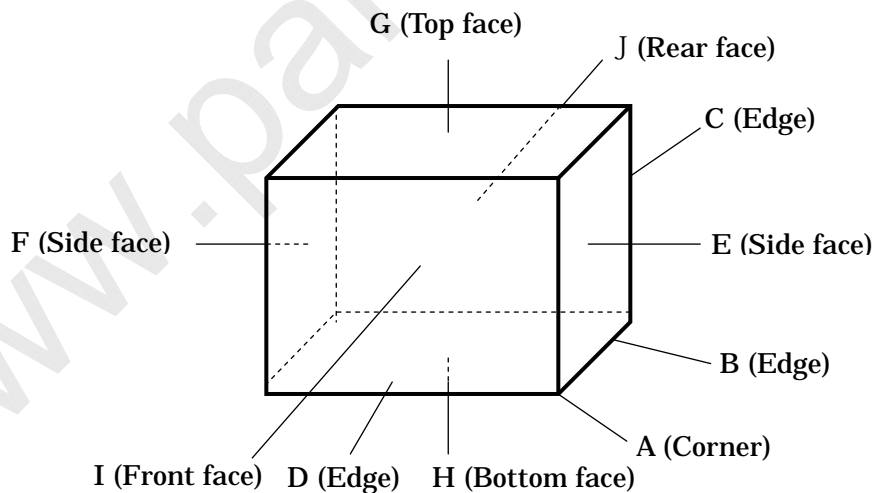

Fig.12-1. Direction to apply shock to package

DOCUMENT CONTROL SECTION

DATE

						NA19026-C081	
						Tech Bes LCD-00223	
						CUST.	
EDIT	DATE	DESIG.	CHECK	APPR.	DESCRIPTION	FUJITSU DISPLAY TECHNOLOGIES CORPORATION	
DESIG.			CHECK		APPR.	20/	

【NA19026-C081】

14. INDICATIONS

This module has the following indications.

- (1) Product name : LCD unit
- (2) Model number : NA19026-C081
- (3) Manufacturing number : 3 Y 0 0 0 0 1

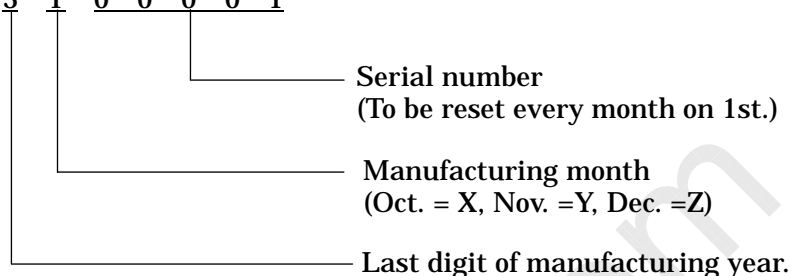

- (4) Caution when changing cold-cathode tubes and disposal method of them. (See Fig. 14-1)

・ WHEN CHANGING COLD CATHODE FLUORESCENT LAMPS, FOLLOW OPERATING SPECIFICATIONS. ESPECIALLY BE CAREFUL ABOUT THE LAMP'S SIDE-EDGE.
 ・ 蛍光管の交換は作業仕様書に従って行って下さい。特に蛍光管ホルダ側面のエッジに気をつけて下さい。
 ・ THIS TFT COLOR LCD CONTAINS COLD CATHODE FLUORESCENT LAMPS. PLEASE FOLLOW LOCAL ORDINANCES OR REGULATIONS FOR ITS DISPOSAL.
 ・ 当該液晶ディスプレイユニットには蛍光管が組み込まれていますので、地方自治体の条例または規則に従って廃棄して下さい。

Fig.14-1



Fig.14-2 Product label (example)

15. PACKAGING

Separately specified in packaging specifications.

15-1. Packaging specifications

- (1) 5 LCD modules / 1 package.
- (2) Weight: approximately 13kg / 1 package.
- (3) Outline dimensions : 348mm(W) × 328(D) × 490mm(H)

15-2. Packaging method

Fig.15-2 (a),(b),(c),(d) show the packing method.

DOCUMENT CONTROL SECTION

						NA19026-C081	
						Tech Bes LCD-00223	
						CUST.	
EDIT	DATE	DESIG.	CHECK	APPR.	DESCRIPTION		FUJITSU DISPLAY TECHNOLOGIES CORPORATION
							21/

【NA19026-C081】

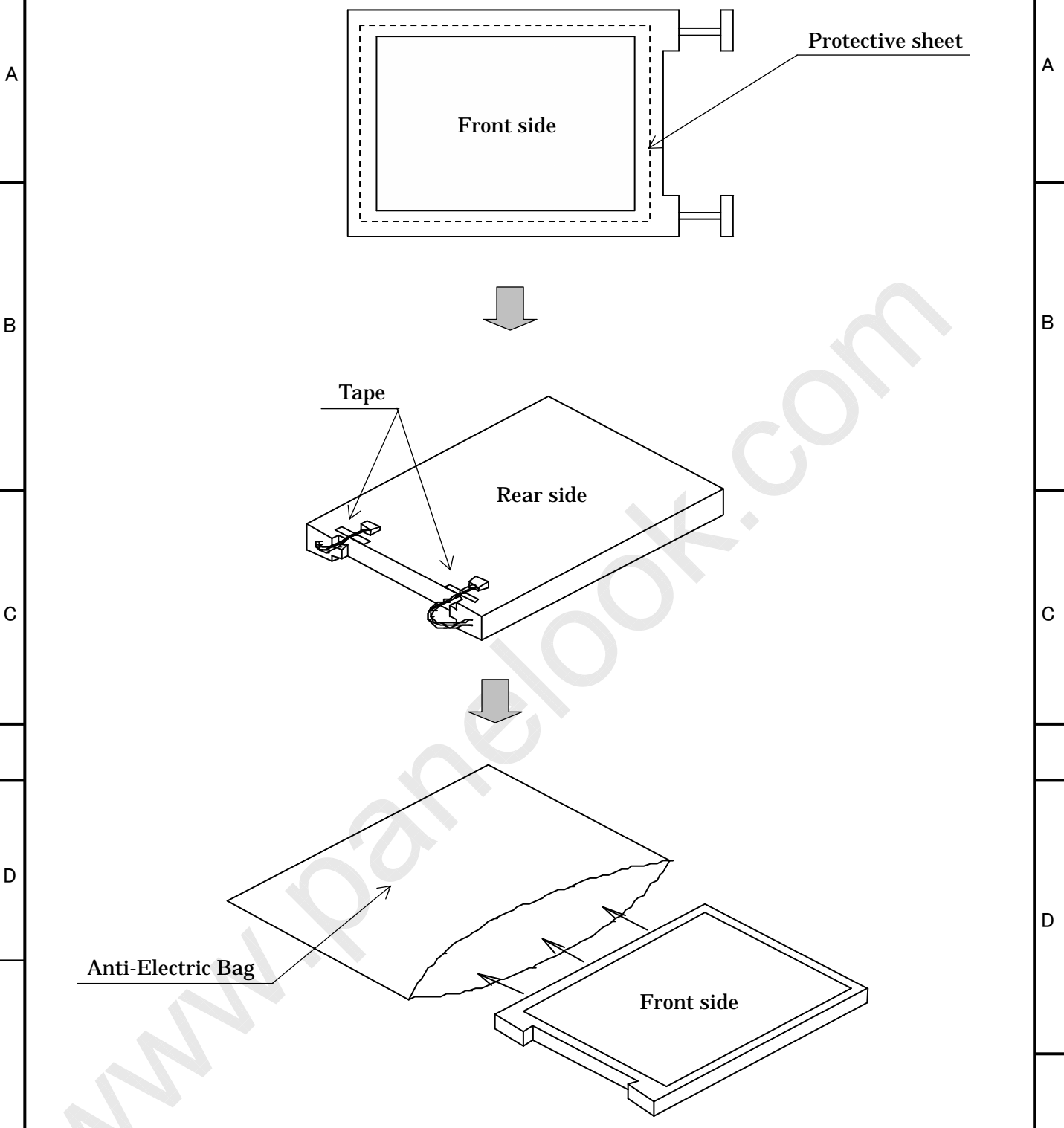

Fig.15-2(a) Packaging Method

DOCUMENT CONTROL SECTION

DATE

						NA19026-C081	
						Tech Bes LCD-00223	
						CUST.	
EDIT	DATE	DESIG.	CHECK	APPR.	DESCRIPTION	FUJITSU DISPLAY TECHNOLOGIES CORPORATION	
DESIG.			CHECK	APPR.		22/	

【NA19026-C081】

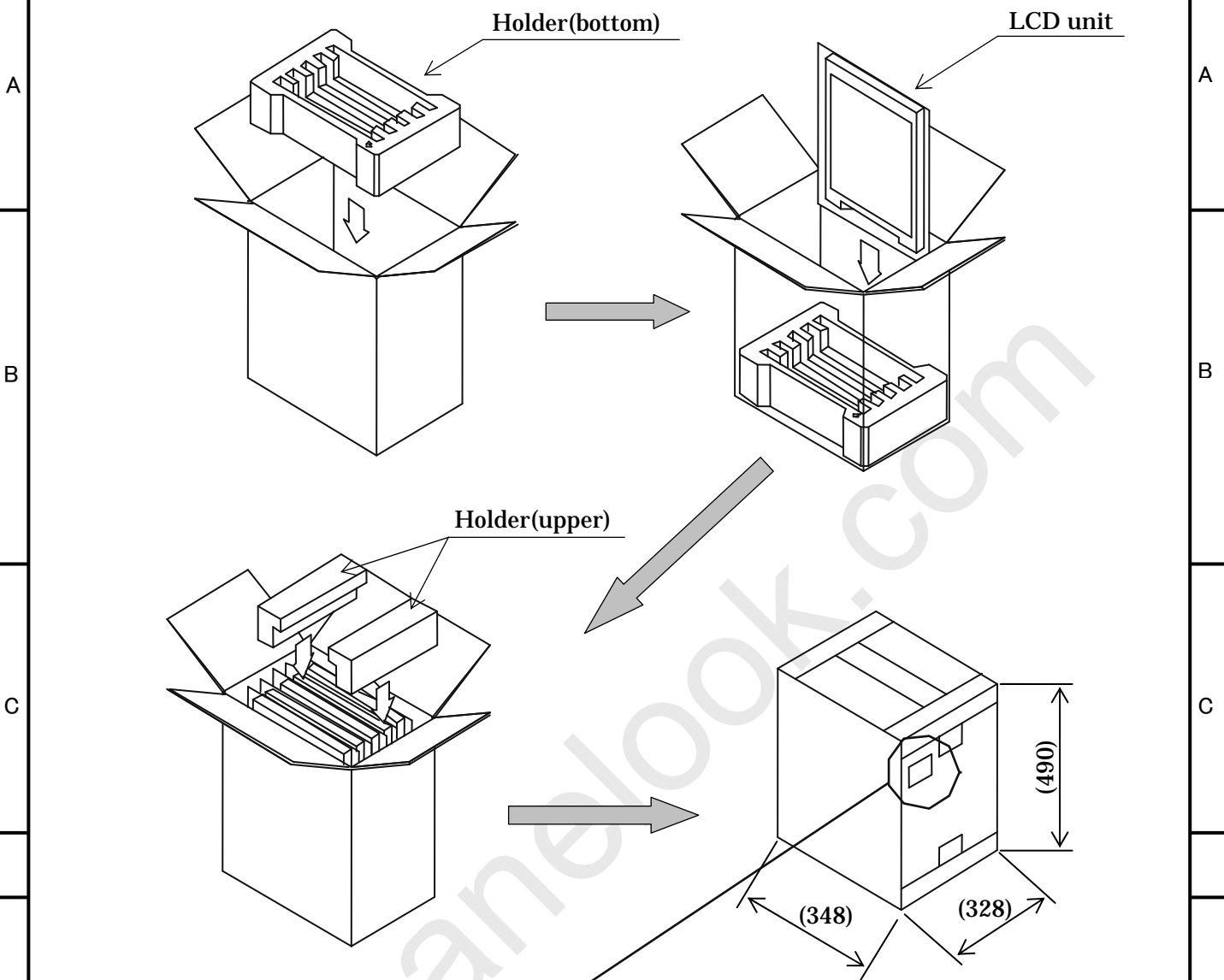

Label(example)

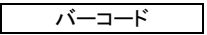
型 格 (TYPE)	NA19026-C081	数 量 (QTY.)	5
图 番 (DRWG. NO.)	9X00001	版 数 (REV. NO.)	01A
	9X00002		
	9X00003		
	9X00004		
	9X00005		
		MADE IN JAPAN	

- Taping
Upper : H or I method
Bottom : H method
- Upper and bottom holders should be anti-electrostatic type.

Fig.15-2(b) Packaging Method

DOCUMENT CONTROL SECTION

						NA19026-C081	
						Tech Bes LCD-00223	
						CUST.	
EDIT	DATE	DESIG.	CHECK	APPR.	DESCRIPTION		FUJITSU DISPLAY TECHNOLOGIES CORPORATION
DESIG.			CHECK		APPR.		23/

【NA19026-C081】

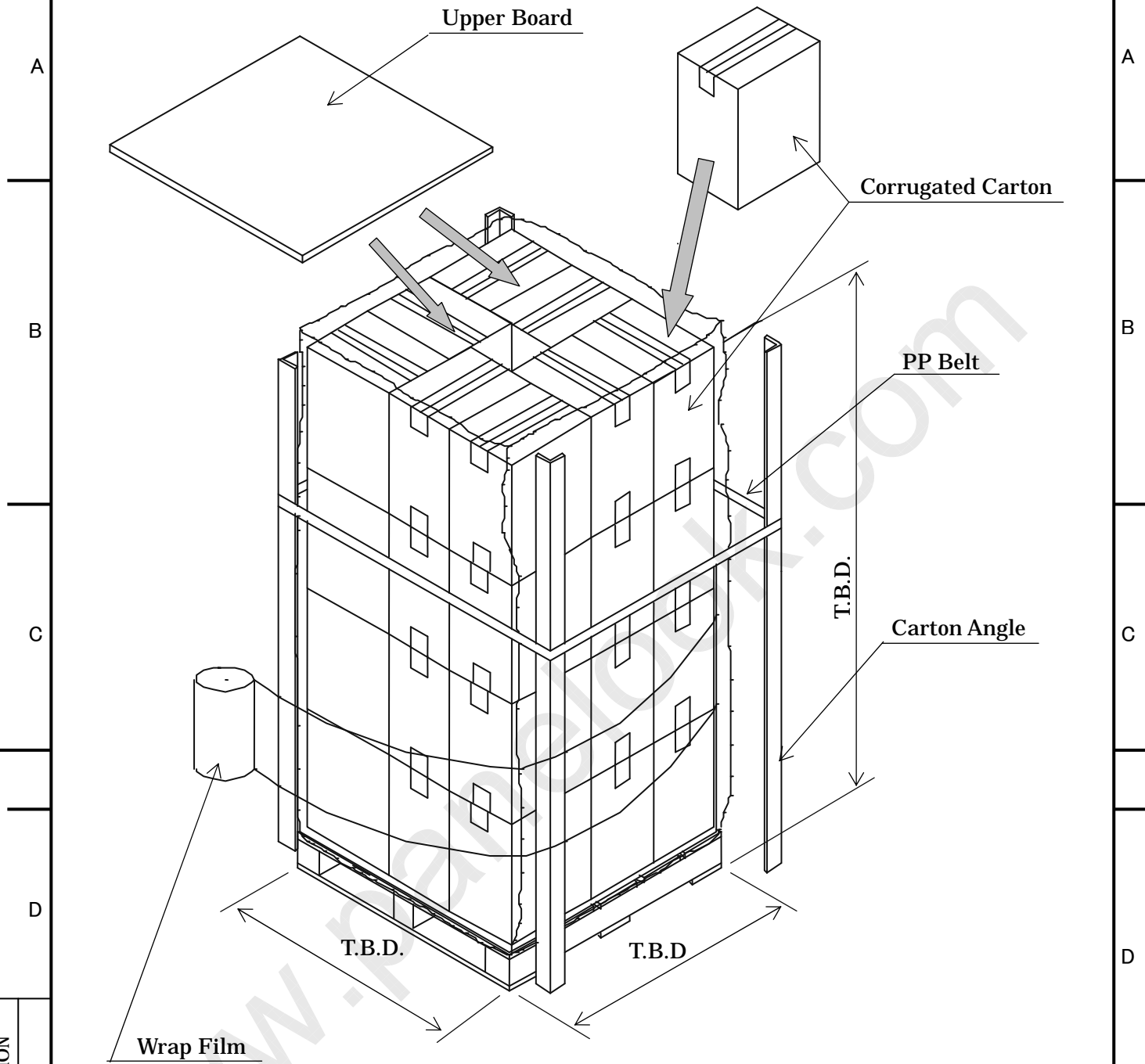
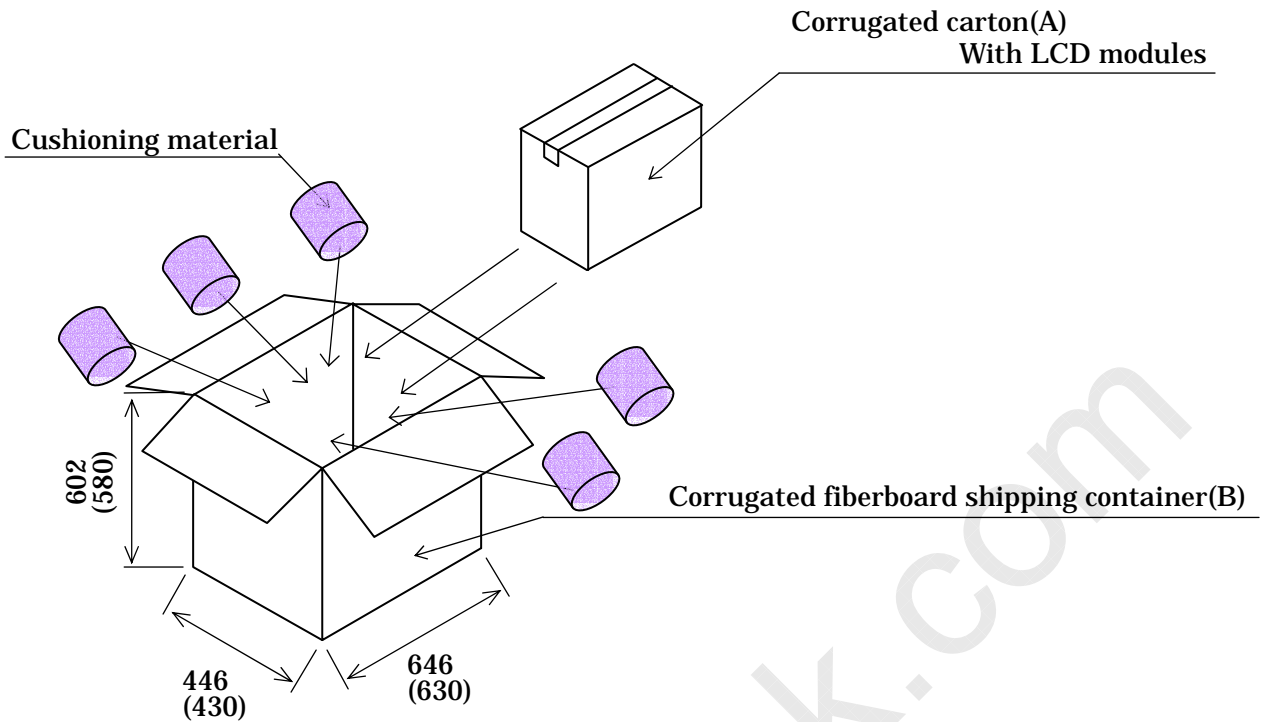

Fig.15-2(c) Packaging Method

DOCUMENT CONTROL SECTION
DATE

						NA19026-C081		
						Tech Bes LCD-00223		CUST.
EDIT	DATE	DESIG.	CHECK	APPR.	DESCRIPTION		FUJITSU DISPLAY TECHNOLOGIES CORPORATION	24/
			CHECK			APPR.		

【NA19026-C081】



Note 1) The carton (A) should be placed in the middle of the container(B) with enough cushioning materials.

Figure.15-2(d) Packaging Method

DOCUMENT CONTROL SECTION
DATE

						NA19026-C081		
						Tech Bes LCD-00223		CUST.
EDIT	DATE	DESIG.	CHECK	APPR.	DESCRIPTION		FUJITSU DISPLAY TECHNOLOGIES CORPORATION	25/
					DESIG.	CHECK	APPR.	

【NA19026-C081】

16.PRECAUTIONS

Adhere to the following precautions to properly use this LCD module.

(1) Fail safe design

LCD module has an inherent chance of failure. Customers must protect against injury, damage or loss from such failures by incorporating safety design measures into your facility and equipment such as redundancy, fire protection, and prevention of over-current levels and other abnormal operating conditions.

(2) Handling of LCD panel

① Do not apply any strong mechanical shock to the LCD panel.

Since the LCD panel is made of glass, excessive shock may damage the panel or cause a malfunction.

② Do not press hard on the LCD panel surface. (Max 2.0kg/cm²)

In the LCD panel, the gap between two glass plates is kept precisely and uniformly to maintain display's characteristics and reliability. If this panel is pressed hard, the following troubles occurs.

- (a) Ununiformity of color
- (b) Orientation of liquid crystal becomes disordered

Problem (a) returns to normal after a while. Problem (b) returns to normal if power is shut off once then turned on again.

However these operations should be avoided to insure reliability.

③ Do not scratch the polarizer film on the LCD panel surface.

- Do not press or rub the display surface with a hard tool, pincet, etc.
- For handling, use cotton or conductive gloves so that the display surface is not stained.
- For If the display surface is stained by dust or dirt, clean it as follows with a soft cloth (deer skin, etc.)

[Dust] Wipe off with a soft cloth. (do not rub.)

[Dirt] Wipe off lightly with a soft cloth after soaking in the clear water and squeezing hard out of water drops. Only if the dirt is hardly wiped off, use isopropyl alcohol or ethanol.

Be careful not to splash the water or the solvent and water penetrated between the polarizer and the LCD panel.

Do not use solvents such as ketone (acetone, etc.) and aromatics (xylene, toluene, etc.)

- If saliva or water drops are left for long time, it may deform partial deformation or discolored. Wipe off immediately in the same way as for dirt.
- Do not allow oil to adhere to the module, since the cleaning of oil is difficult.

④ Do not place or contact objects on the display surface for a long period of time.

That's because this may make some parts of the LCD module distorted and the display quality may decline.

DOCUMENT CONTROL SECTION

DATE

						NA19026-C081	
						Tech Bes LCD-00223	
						CUST.	
EDIT	DATE	DESIG.	CHECK	APPR.	DESCRIPTION		FUJITSU DISPLAY TECHNOLOGIES CORPORATION
DESIG.			CHECK		APPR.		26/

【NA19026-C081】

(3) Handling of LCD module

- ① **Do not pull the cold-cathode tube cable strongly.**
If the cable is pulled with the load of 2kg or more, the cable may be damaged or reliability may decrease.
- ② **Assemble the module into user's system in a dust free environment.**
If conductive foreign matter adheres to the module, failures may occur.
- ③ **Take anti-static measures for assembling the module.**
Since the LCD module contains CMOS-ICs, the following considerations are necessary.
 - For assembling the module, operator should be grounded and wear cotton or conductive gloves.
 - Floor of work area and work table to assemble the LCD module should be covered with electrostatic shielding in order to discharge static electricity via an earth wire.
 - If necessary, ground operation tools (soldering iron, radio pliers, pincet, etc.).
 - Do not take the module out of the conductive bag until the time when the module is assembled.
 - Assemble the module under low humidity (50%RH or less).
- ④ **Do not pull the connecting cable on the rear face of the LCD module strongly.**
- ⑤ **Do not disassemble or remodel the LCD module.**
If this LCD module is disassembled or remodeled, it may have some trouble, or the display quality and reliability may not be assured.

(4) Precautions for operating the LCD module

- ① **Adhere to the specified power supply sequence.**
If not followed, the CMOS-IC may cause a latch-up, or the DC voltage may be applied the liquid crystal, and a failure or serious deterioration in display quality may occur.
- ② **Do not operate the LCD module when condensation is present.**
If the LCD module is operated when condensation is on the terminals of the LCD panel, the terminals cause electrochemical reaction, and may reach disconnection. Condensation easily occurs especially when the module is moved from a cold environment to a warm environment.
- ③ **Trouble that occurs when the LCD module is used at not recommended temperature.**
 - Operation at high temperature(>60°C) :Display colors shift to blue.
 - Storage at high temperature(>60°C) :The polarizer film deteriorates and contrast decreases.
 - Operation at low temperature(<0°C) :The response speed decreases considerably.
 - Storage at low temperature (<-20°C) :The liquid crystal may solidify and become damaged.
- ④ **Always input the control signals at the correct timing.**
If control signals (DCLK, or ENAB) are not input, or if the timing is out of the specified timing, DC voltage may be applied to the liquid crystal and, as a result, cause image sticking or deterioration of contrast.

DOCUMENT CONTROL SECTION

						NA19026-C081	
						Tech Bes LCD-00223	
						CUST.	
EDIT	DATE	DESIG.	CHECK	APPR.	DESCRIPTION		FUJITSU DISPLAY TECHNOLOGIES CORPORATION
DESIG.			CHECK		APPR.		27/

【NA19026-C081】

(5) Precautions on designing module mounting

- ① **Do not press the display surface and bottom face of the LCD module.**
Display quality or reliability may be deteriorated if the installation of the LCD module is inappropriate and, as a result, excessive pressure is applied to the surface of LCD screen. Brightness uniformity or the reliability of CCFL may decrease if the pressure is applied to the backlight module.
- ② **Consider the module mounting design, so that twisting and bending do not occur to the LCD module.**
Excessive twisting and bending may damage display quality and reliability.
- ③ **The power cable length between the LCD module and inverter should not be extended.**
Otherwise the backlight may not light or flickering may occur.
- ④ **Do not make the power cable of the backlight clung to a metal plate, etc.**
Backlight frequency current for backlight driving may leak to the metal and desired brightness may not be assured.
- ⑤ **When Mounting LCD module with M4 screw(x4) should be screw up under 5.75kgf-cm torque.**

(6) Storage method

- ① **Do not store the LCD module in an atmosphere of organic solvent or corrosive gas.**
In an organic solvent atmosphere, the polarizer film discolors and display quality deteriorates.
In a corrosive gas environment, various problems may occur.
- ② **Store the LCD module in a Fujitsu package.**
At storing, Fujitsu packages can be stacked up to 4 boxes.
The LCD module is in an anti-static bag. Keep the module in that status.
- ③ **It is recommended that the storage environment should be humidity controlled, cool and dark.**
Recommended storage environment
 - Place :Dark (avoid direct sunlight)
 - Temperature : 10~35°C
 - Humidity : 50~60%RH
 Note) If the module is left in an environment of 60°C or more for a long period of time, optical characteristics may deteriorate.

(7) Storage method

- ① **If the LCD panel is damaged, do not inhale or allow the liquid crystal to enter the mouth**
If the liquid crystal contacts the body or cloths, wash it off with soap immediately. Follow precautions for regular electronic components.
- ② **Solder flux on the printed circuit board is harmless to the quality and reliability of LCD module.**
Fujitsu is practicing non-wash technology on module assembly process.

DOCUMENT CONTROL SECTION

						NA19026-C081	
						Tech Bes LCD-00223	
						CUST.	
EDIT	DATE	DESIG.	CHECK	APPR.	DESCRIPTION		
DESIG.			CHECK		FUJITSU DISPLAY TECHNOLOGIES CORPORATION		
						28/	

【NA19026-C081】

17. PRECAUTIONS FOR USE

This Product is designed, developed and manufactured as contemplated for general use, including without limitation, general office use, personal use, household use, and ordinary industrial use, but is not designed, developed and manufactured as contemplated for use accompanying fatal risks or dangers that, unless extremely high safety is secured, could lead directly to death, personal injury, severe physical damage or other loss (hereinafter "High Safety Required Use"), including without limitation, nuclear reaction control in nuclear facility, aircraft flight control, air traffic control, mass transport control, medical life support system, missile launch control in weapon system. If customer's product possibly falls under the category of High Safety Required Use, please consult with our sales representatives in charge before such use. In addition, FDTC shall not be liable against the customer and/or any third party for any claims or damages arising in connection with the High Safety Required Use of the Product without permission.

18. MISCELLANEOUS

Specifications of the TFT-LCD panel and other components used in the LCD module are subject to change. Both parties shall discuss together before change.
 If any doubt is raised in the content of the specifications, both parties shall discuss and make best effort for the agreement.

DOCUMENT CONTROL SECTION
DATE

						NA19026-C081		
						Tech Bes LCD-00223		CUST.
EDIT	DATE	DESIG.	CHECK	APPR.	DESCRIPTION		FUJITSU DISPLAY TECHNOLOGIES CORPORATION	29/
					DESIG.	CHECK	APPR.	

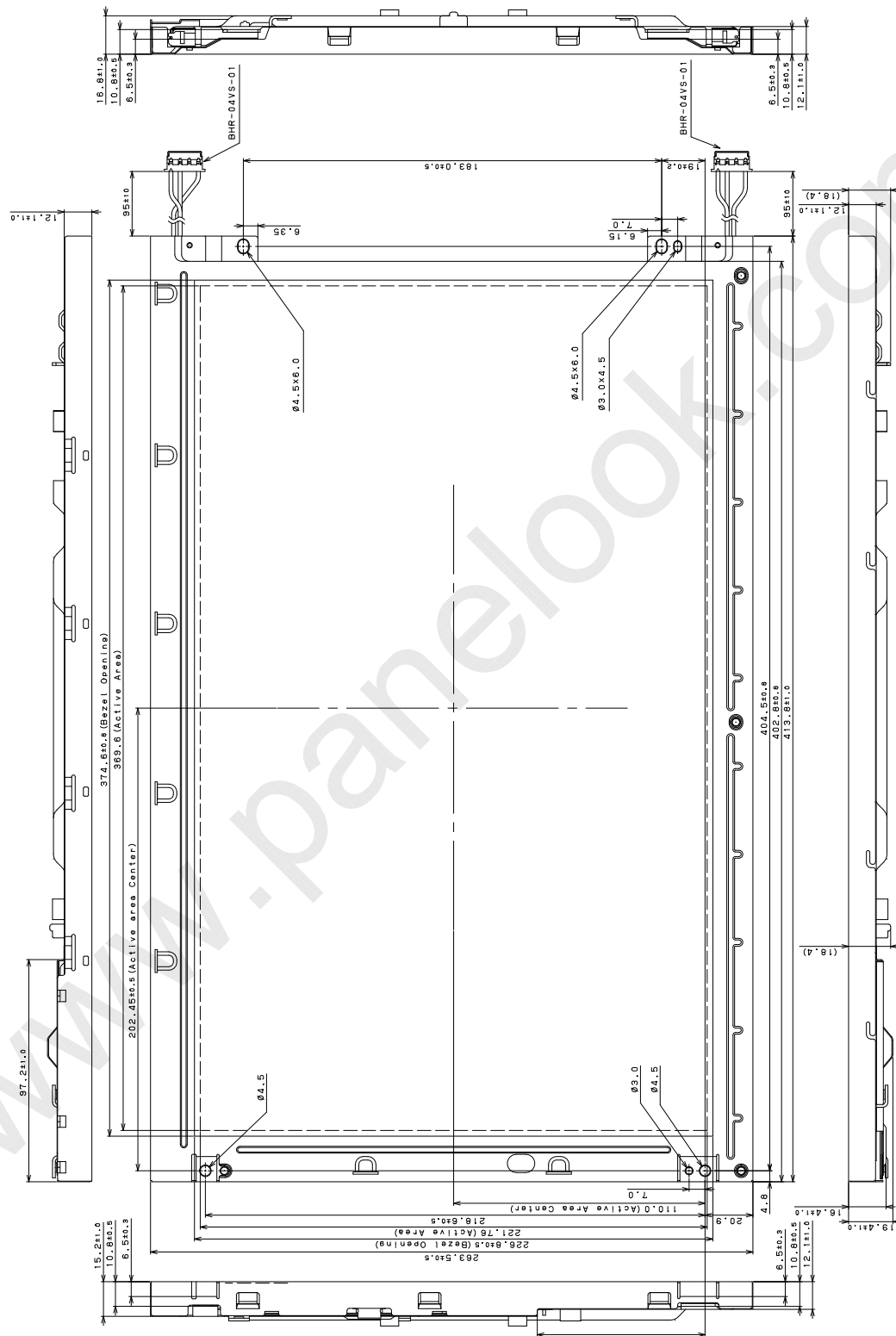

Front View

DATE	NO.	REV.	DESCRIPTION	DATE	NO.	REV.	DESCRIPTION

TITLE: NAI19026-C081
DRAWING: Tech Res LCD-0823
DRAWING NO: 30 /
DATE: 2019.08.23
DESIGNER: CHEN
CHECKER: CHEN
APPROVER: CHEN

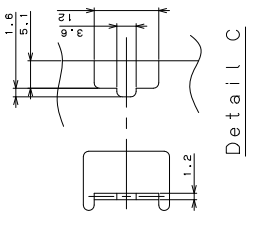
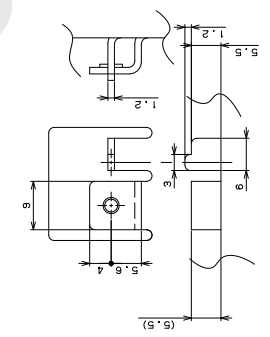
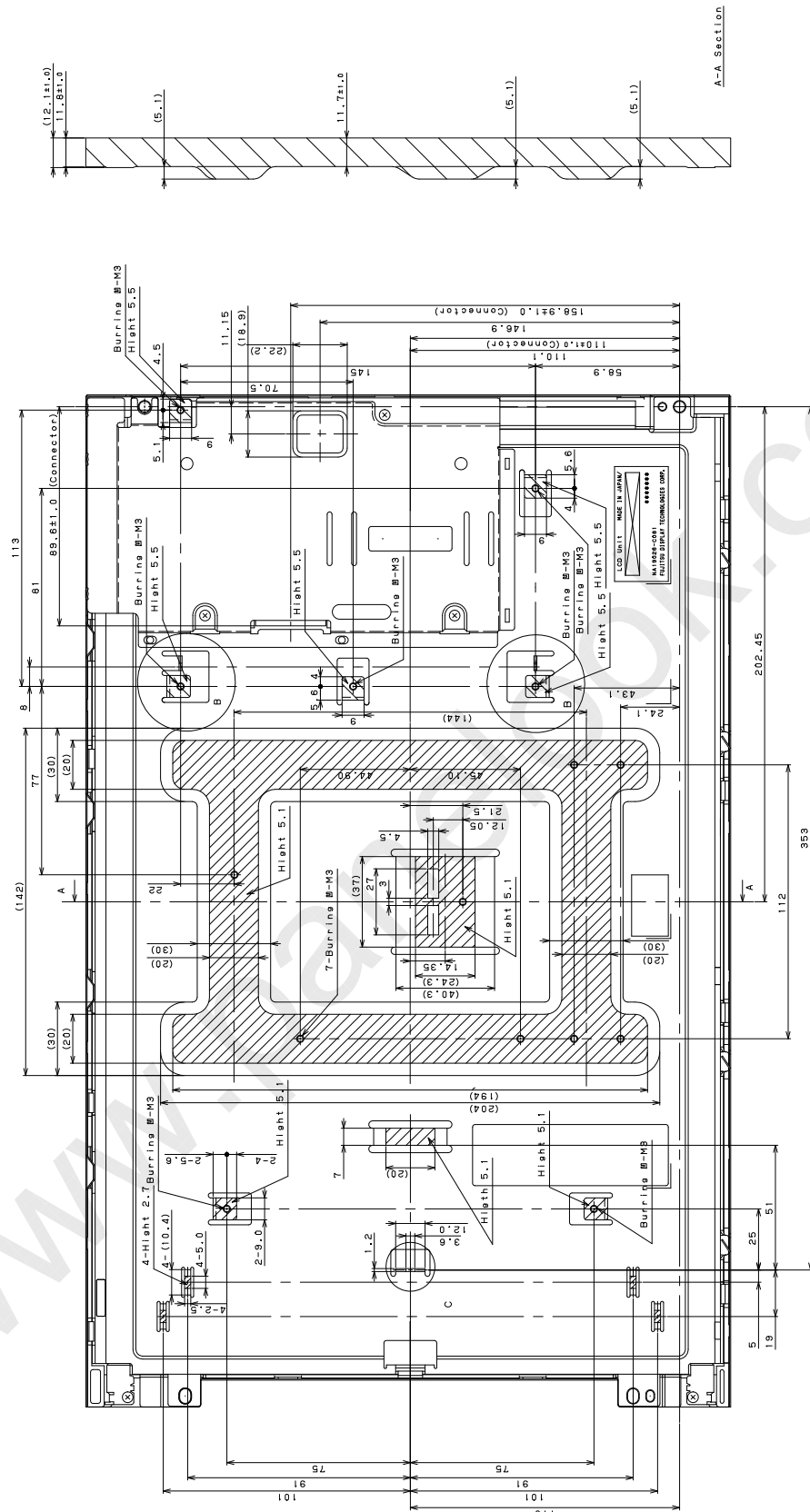

A-A Section

TITLE		NAI9026-C081	
DATE	REV.	DESCRIPTION	APP.
11/31/01	1	INITIAL DESIGN	YJH
12/11/01	2	REVISION	YJH
01/11/02	3	REVISION	YJH
02/11/02	4	REVISION	YJH
03/11/02	5	REVISION	YJH
04/11/02	6	REVISION	YJH
05/11/02	7	REVISION	YJH
06/11/02	8	REVISION	YJH
07/11/02	9	REVISION	YJH
08/11/02	10	REVISION	YJH
09/11/02	11	REVISION	YJH
10/11/02	12	REVISION	YJH
11/11/02	13	REVISION	YJH
12/11/02	14	REVISION	YJH
01/11/03	15	REVISION	YJH