

NAND512xxA2D

512-Mbit, 528-byte/264-word page,
1.8 V/3 V, SLC NAND flash memories

Features

- High density SLC NAND flash memories
 - 512 Mbit memory array
 - Cost effective solutions for mass storage applications
- NAND interface
 - x8 or x16 bus width
 - Multiplexed address/data
- Supply voltage: 1.8 V, 3 V
- Page size
 - x8 device: (512 + 16 spare) bytes
 - x16 device: (256 + 8 spare) words
- Block size
 - x8 device: (16 K + 512 spare) bytes
 - x16 device: (8 K + 256 spare) words
- Page read/program
 - Random access:
12 μs (3 V)/15 μs (1.8 V) (max)
 - Sequential access:
30 ns (3 V)/50 ns (1.8 V) (min)
 - Page program time: 200 μs (typ)
- Copy back program mode
- Fast block erase: 1.5 ms (typ)
- Status register
- Electronic signature
- Chip Enable 'don't care'
- Hardware data protection: program/erase locked during power transitions
- Security features
 - OTP area

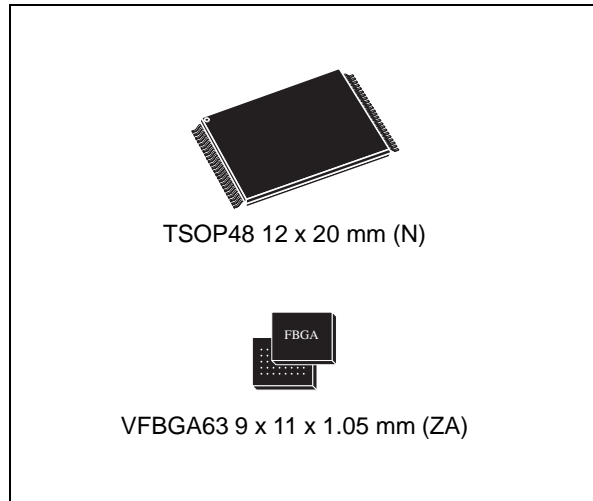

- Serial number (unique ID)
- Data integrity
 - 100,000 program/erase cycles (with ECC)
 - 10 years data retention
- RoHS compliant packages
- Development tools
 - Error correction code models
 - Bad blocks management and wear leveling algorithms
 - Hardware simulation models

Table 1. Device summary

NAND512xxA2D
NAND512R3A2D
NAND512R4A2D
NAND512W3A2D
NAND512W4A2D

Contents

- 1 Description 6**
- 2 Memory array organization 11**
- 3 Signals description 13**
 - 3.1 Inputs/outputs (I/O0-I/O7) 13
 - 3.2 Inputs/outputs (I/O8-I/O15) 13
 - 3.3 Address Latch Enable (AL) 13
 - 3.4 Command Latch Enable (CL) 13
 - 3.5 Chip Enable (\bar{E}) 13
 - 3.6 Read Enable (\bar{R}) 14
 - 3.7 Write Enable (\bar{W}) 14
 - 3.8 Write Protect (\bar{WP}) 14
 - 3.9 Ready/Busy (\bar{RB}) 14
 - 3.10 V_{DD} supply voltage 14
 - 3.11 V_{SS} ground 15
- 4 Bus operations 16**
 - 4.1 Command input 16
 - 4.2 Address input 16
 - 4.3 Data input 16
 - 4.4 Data output 16
 - 4.5 Write protect 17
 - 4.6 Standby 17
- 5 Command set 19**
- 6 Device operations 20**
 - 6.1 Pointer operations 20
 - 6.2 Read memory array 21
 - 6.2.1 Random read 21
 - 6.2.2 Page read 22
 - 6.2.3 Sequential row read 22

6.3	Page program	24
6.4	Copy back program	25
6.5	Block erase	26
6.6	Reset	26
6.7	Read status register	27
6.7.1	Write protection bit (SR7)	27
6.7.2	P/E/R controller bit (SR6)	27
6.7.3	Error bit (SR0)	27
6.7.4	SR5, SR4, SR3, SR2 and SR1 are reserved	27
6.8	Read electronic signature	28
7	Software algorithms	29
7.1	Bad block management	29
7.2	NAND flash memory failure modes	29
7.3	Garbage collection	31
7.4	Wear-leveling algorithm	31
7.5	Error correction code	31
8	Program and erase times and endurance cycles	32
9	Maximum ratings	32
10	DC and AC parameters	33
10.1	Ready/Busy signal electrical characteristics	44
10.2	Data protection	46
11	Package mechanical	47
12	Ordering information	50
13	Revision history	51

List of tables

Table 1.	Device summary	1
Table 2.	Product description	7
Table 3.	Signals names	8
Table 4.	Valid blocks.	11
Table 5.	Bus operations	17
Table 6.	Address insertion, x8 devices	17
Table 7.	Address insertion, x16 devices	17
Table 8.	Address definition	18
Table 9.	Commands	19
Table 10.	Copy back program addresses	25
Table 11.	Status register bits	27
Table 12.	Electronic signature	28
Table 13.	NAND flash failure modes	30
Table 14.	Program, erase times and program erase endurance cycles	32
Table 15.	Absolute maximum ratings	32
Table 16.	Operating and AC measurement conditions.	33
Table 17.	Capacitance	33
Table 18.	DC characteristics, 1.8 V devices	34
Table 19.	DC characteristics, 3 V devices	35
Table 20.	AC characteristics for command, address, data input	35
Table 21.	AC characteristics for operations	36
Table 22.	TSOP48 - 48 lead plastic thin small outline, 12 x 20 mm, package mechanical data.	47
Table 23.	VFBGA63 9 x 11 x 1.05 mm - 6 x 8 +15, 0.80 mm pitch, package mechanical data	49
Table 24.	Ordering information scheme	50
Table 25.	Document revision history	51

List of figures

Figure 1. Logic diagram 7

Figure 2. Logic block diagram 8

Figure 3. TSOP48 connections - x8 devices 9

Figure 4. VFBGA63 connections - x8 devices (top view through package). 10

Figure 5. Memory array organization 12

Figure 6. Pointer operations 20

Figure 7. Pointer operations for programming 21

Figure 8. Read (A,B,C) operations 22

Figure 9. Sequential row read operations 23

Figure 10. Sequential row read block diagrams 23

Figure 11. Read block diagrams 23

Figure 12. Page program operation 24

Figure 13. Copy back operation 25

Figure 14. Block erase operation 26

Figure 15. Bad block management flowchart 30

Figure 16. Garbage collection 31

Figure 17. Equivalent testing circuit for AC characteristics measurement 34

Figure 18. Command Latch AC waveforms 37

Figure 19. Address Latch AC waveforms 37

Figure 20. Data Input Latch AC waveforms 38

Figure 21. Sequential data output after read AC waveforms 38

Figure 22. Read status register AC waveforms 39

Figure 23. Read electronic signature AC waveforms 39

Figure 24. Page read A/ read B operation AC waveforms 40

Figure 25. Read C operation, one page AC waveforms 41

Figure 26. Page program AC waveforms 42

Figure 27. Block erase AC waveforms 43

Figure 28. Reset AC waveforms 43

Figure 29. Program/erase enable waveforms 44

Figure 30. Program/erase disable waveforms 44

Figure 31. Ready/Busy AC waveform 45

Figure 32. Ready/Busy load circuit 45

Figure 33. Resistor value versus waveform timings for Ready/Busy signal 46

Figure 34. Data protection 46

Figure 35. TSOP48 - 48 lead plastic thin small outline, 12 x 20 mm, package outline 47

Figure 36. VFBGA63 9 x 11 x 1.05 mm - 6 x 8 +15, 0.80 mm pitch, package outline 48

1 Description

The NAND flash 528-byte/264-word page is a family of non-volatile flash memories that uses the single level cell (SLC) NAND technology. It is referred to as the small page family. The NAND512xxA2D devices have a density of 512 Mbits. They operate with either a 1.8 V or 3 V voltage supply. The size of a page is either 528 bytes (512 + 16 spare) or 264 words (256 + 8 spare) depending on whether the device has a x8 or x16 bus width.

The address lines are multiplexed with the data input/output signals on a multiplexed x8 or x16 input/output bus. This interface reduces the pin count and makes it possible to migrate to other densities without changing the footprint.

To extend the lifetime of NAND flash devices it is mandatory to implement an error correction code (ECC). The use of ECC correction allows to achieve up to 100,000 program/erase cycles for each block. A write protect pin is available to give a hardware protection against program and erase operations.

The devices feature an open-drain ready/busy output that can be used to identify if the program/erase/read (P/E/R) controller is currently active. The use of an open-drain output allows the ready/busy pins from several memories to be connected to a single pull-up resistor.

A Copy Back command is available to optimize the management of defective blocks. When a page program operation fails, the data can be programmed in another page without having to resend the data to be programmed.

The NAND512xxA2D devices are available in the TSOP48 (12 x 20 mm) and VFBGA63 (9 x 11 x 1.05 mm) packages.

The NAND512xxA2D devices are available in two different versions:

- No option (Chip Enable 'care', sequential row read enabled): the sequential row read feature allows to download up to all the pages in a block with one read command and addressing only the first page to read
- With Chip Enable 'don't care' feature. This enables the sharing of the bus between more active memories that are simultaneously active as Chip Enable transitions during latency do not stop read operations. Program and erase operations are not interrupted by Chip Enable transitions.

and come with two security features:

- OTP (one time programmable) area, which is a restricted access area where sensitive data/code can be stored permanently. The access sequence and further details about this feature are subject to an NDA (non disclosure agreement)
- Serial number (unique identifier), which enables each device to be uniquely identified. It is subject to an NDA and is, therefore, not described in the datasheet.

For more details about these security features, contact your nearest Numonyx sales office.

For information on how to order these options refer to [Table 24: Ordering information scheme](#). Devices are shipped from the factory with block 0 always valid and the memory content bits, in valid blocks, erased to '1'.

[Table 2: Product description](#) lists the part numbers and other information for all the devices in the family.

Table 2. Product description

Reference	Part number	Density	Bus width	Page size	Block size	Memory array	Operating voltage	Timings				Package
								Random access Max	Sequential access Min	Page program Typ	Block erase Typ	
NAND512xxA2D	NAND512R3A2D	512 Mbits	x8	512+16 bytes	16K+512 bytes	32 pages x 4096 blocks	1.7 to 1.95 V	15 μ s	50 ns	200 μ s	2 ms	TSOP48 VFBGA63
	2.7 to 3.6 V						12 μ s	30 ns				
	x16		256+8 words	8K+256 words	1.7 to 1.95 V		15 μ s	50 ns				
					2.7 to 3.6 V		12 μ s	30 ns				

Figure 1. Logic diagram

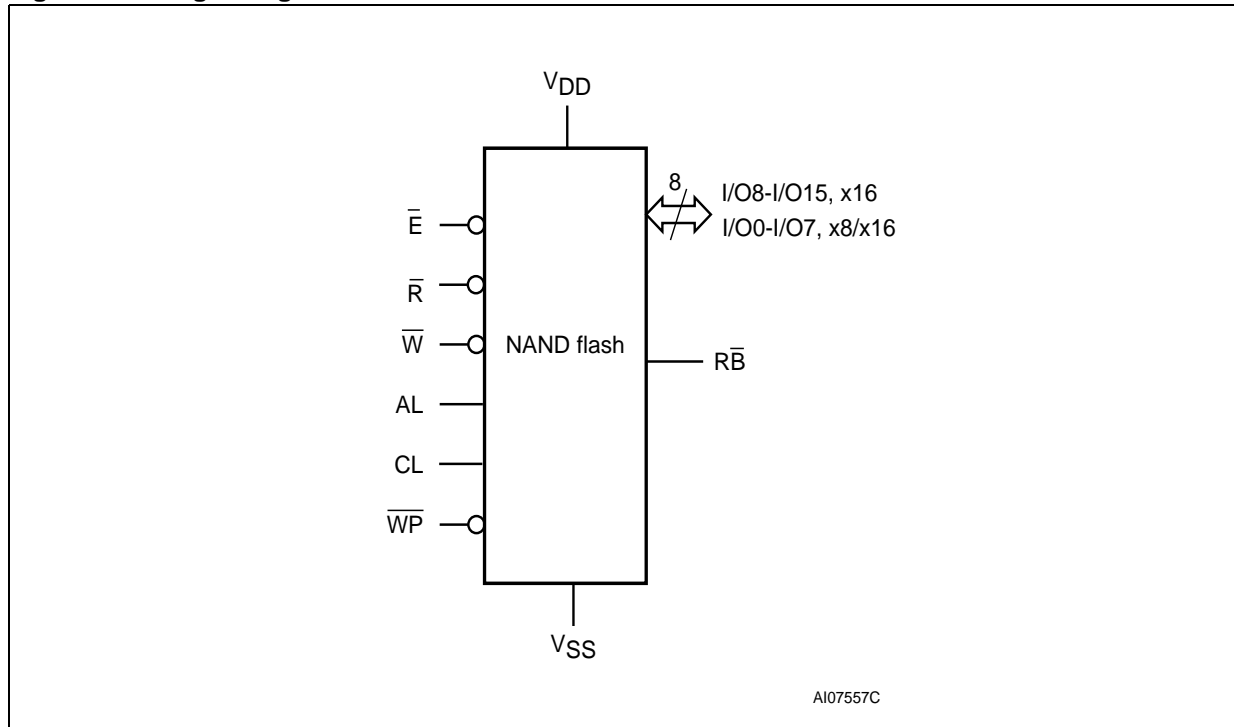

Table 3. Signals names

Signal	Function	Direction
I/O8-I/O15	Data input/outputs for x16 devices	I/O
I/O0-I/O7	Data inputs/outputs, address inputs, or command inputs for x8 and x16 devices	I/O
AL	Address Latch Enable	Input
CL	Command Latch Enable	Input
\bar{E}	Chip Enable	Input
\bar{R}	Read Enable	Input
\bar{RB}	Ready/Busy (open-drain output)	Output
\bar{W}	Write Enable	Input
\bar{WP}	Write Protect	Input
V _{DD}	Supply voltage	Power supply
V _{SS}	Ground	Ground
NC	Not connected internally	–
DU	Do not use	–

Figure 2. Logic block diagram

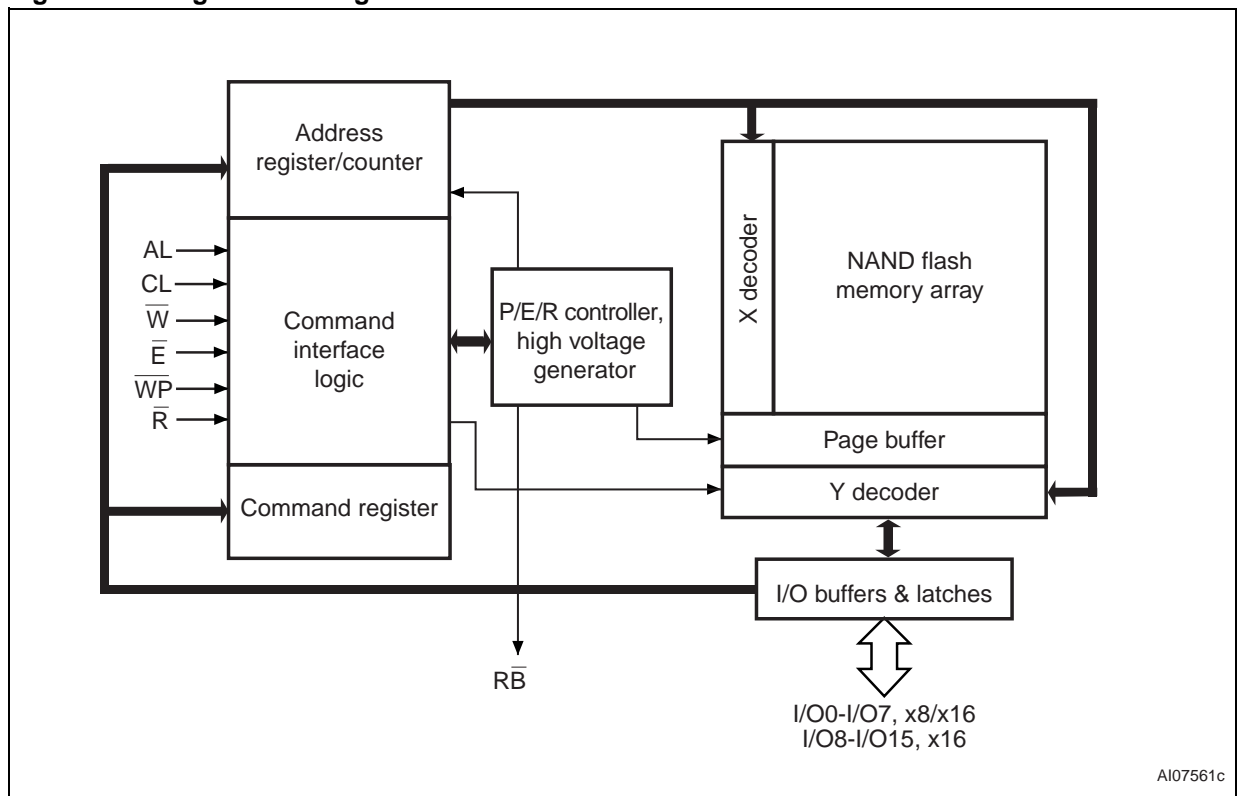

Figure 3. TSOP48 connections - x8 devices

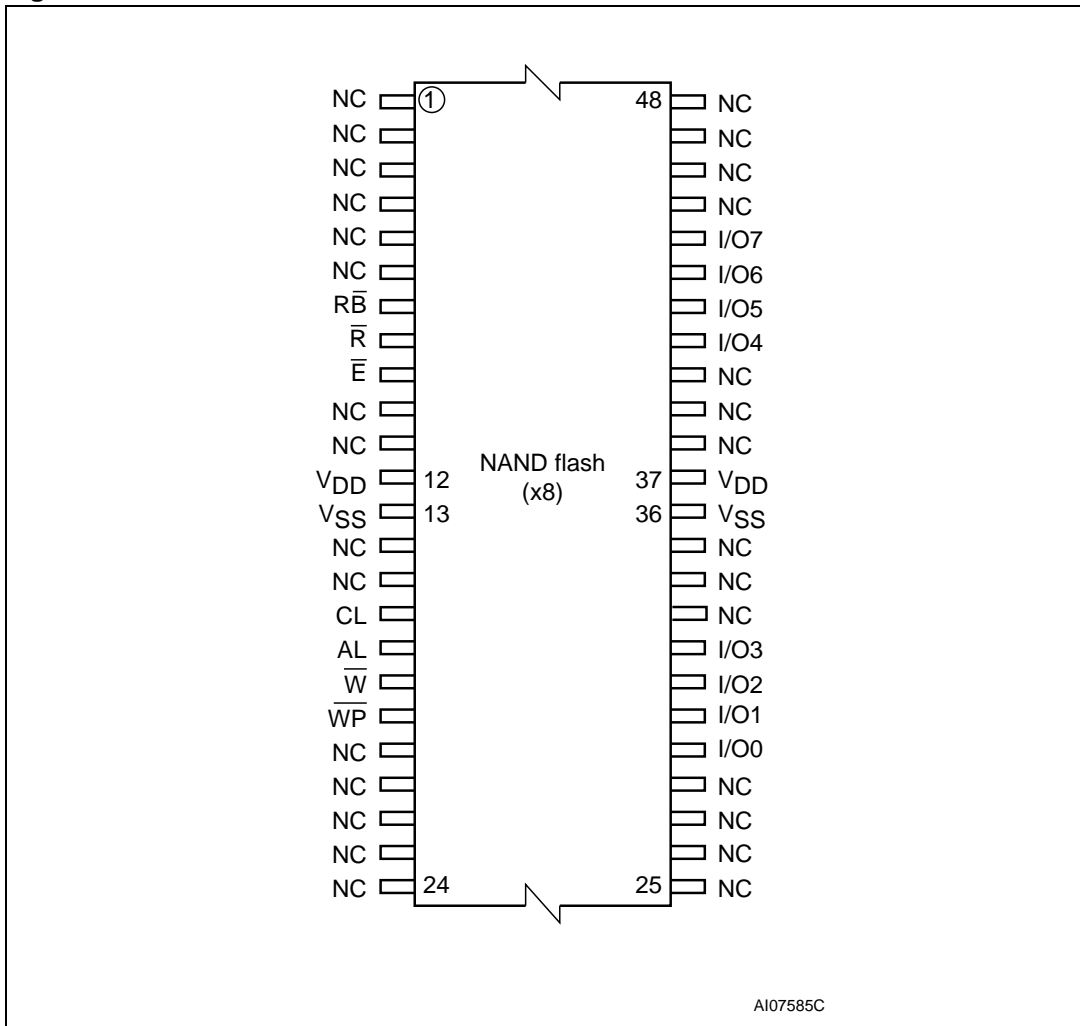
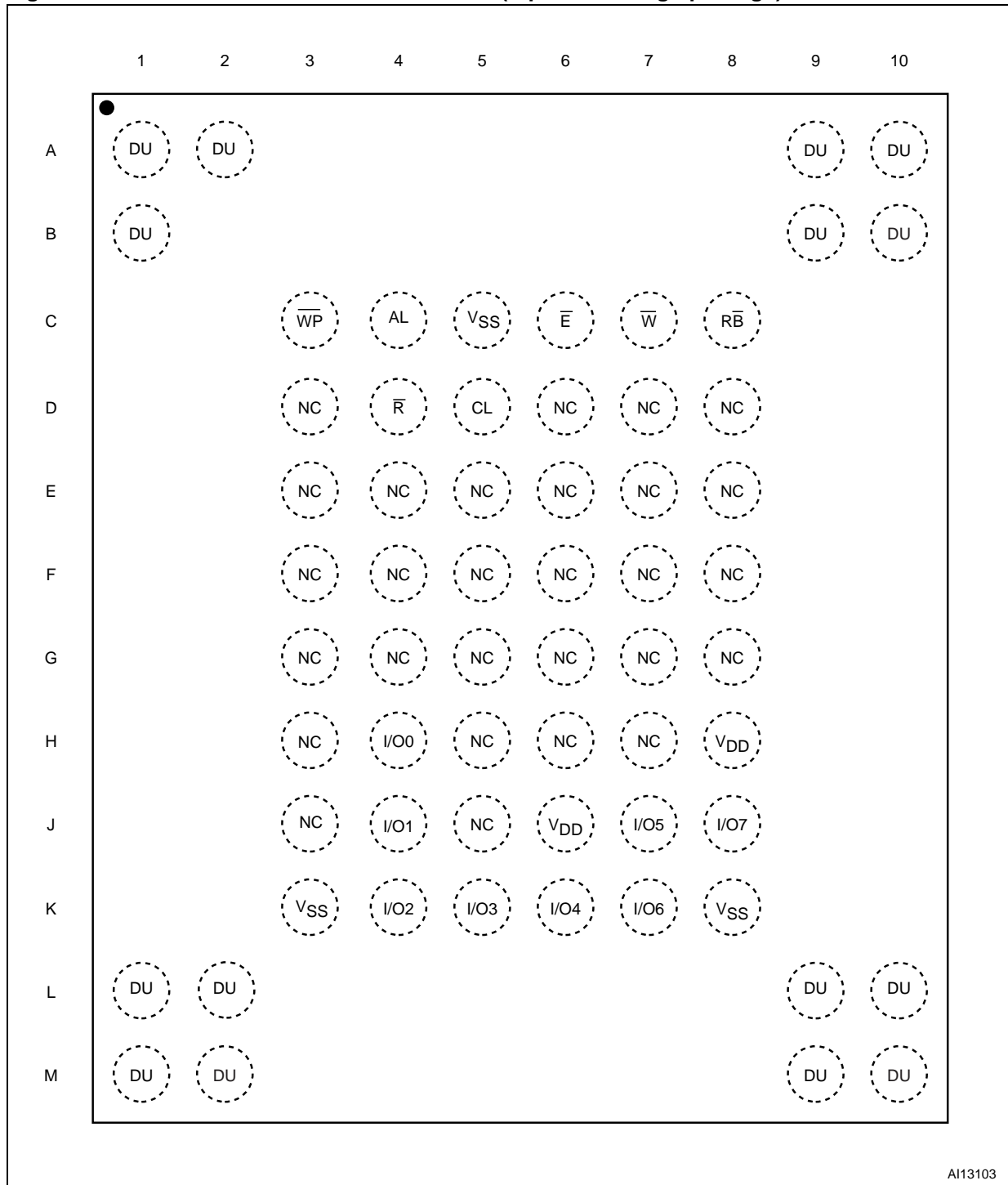

Figure 4. VFBGA63 connections - x8 devices (top view through package)



AI13103

2 Memory array organization

The memory array is made up of NAND structures where 16 cells are connected in series.

The memory array is organized in blocks where each block contains 32 pages. The array is split into two areas, the main area and the spare area. The main area of the array is used to store data whereas the spare area is typically used to store error correction codes, software flags or bad block identification.

In x8 devices the pages are split into a main area with two half pages of 256 bytes each and a spare area of 16 bytes. In the x16 devices the pages are split into a 256-word main area and an 8-word spare area. Refer to [Figure 5: Memory array organization](#).

Bad blocks

The NAND flash 528-byte/264-word page devices may contain bad blocks, that is blocks that contain one or more invalid bits whose reliability is not guaranteed. Additional bad blocks may develop during the lifetime of the device.

The bad block information is written prior to shipping (refer to [Section 7.1: Bad block management](#) for more details).

[Table 4](#) shows the minimum number of valid blocks in each device. The values shown include both the bad blocks that are present when the device is shipped and the bad blocks that could develop later on.

These blocks need to be managed using bad blocks management, block replacement or error correction codes (refer to [Section 7: Software algorithms](#)).

Table 4. Valid blocks

Density of device	Min	Max
512 Mbits	4016	4096

Figure 5. Memory array organization

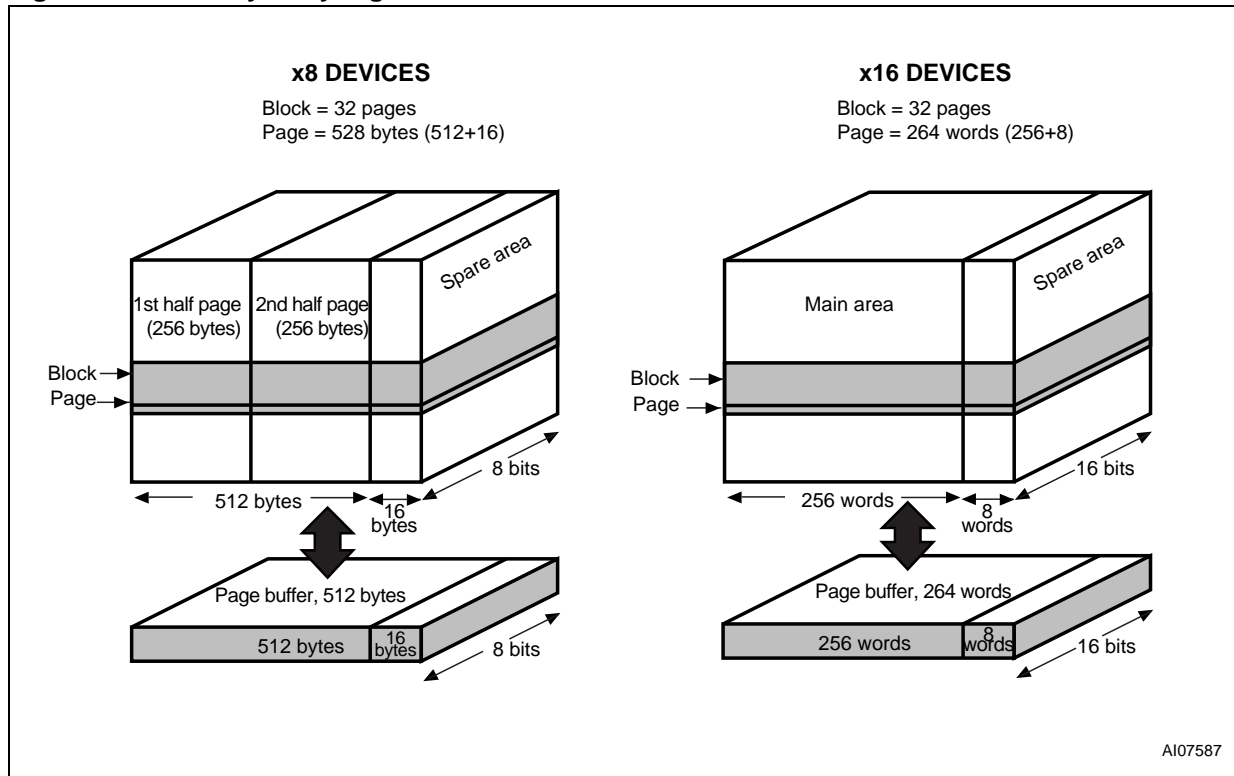

3 Signals description

See [Figure 1: Logic diagram](#), and [Table 3: Signals names](#), for a brief overview of the signals connected to this device.

3.1 Inputs/outputs (I/O0-I/O7)

Inputs/outputs 0 to 7 are used to input the selected address, output the data during a read operation or input a command or data during a write operation. The inputs are latched on the rising edge of Write Enable. I/O0-I/O7 are left floating when the device is deselected or the outputs are disabled.

3.2 Inputs/outputs (I/O8-I/O15)

Inputs/outputs 8 to 15 are only available in x16 devices. They are used to output the data during a read operation or input data during a write operation. Command and address inputs only require I/O0 to I/O7.

The inputs are latched on the rising edge of Write Enable. I/O8-I/O15 are left floating when the device is deselected or the outputs are disabled.

3.3 Address Latch Enable (AL)

The Address Latch Enable activates the latching of the address inputs in the command interface. When AL is High, the inputs are latched on the rising edge of Write Enable.

3.4 Command Latch Enable (CL)

The Command Latch Enable activates the latching of the command inputs in the command interface. When CL is High, the inputs are latched on the rising edge of Write Enable.

3.5 Chip Enable (\bar{E})

The Chip Enable input activates the memory control logic, input buffers, decoders and read circuitry. When Chip Enable is Low, V_{IL} , the device is selected.

If Chip Enable goes High (V_{IH}) while the device is busy programming or erasing, the device remains selected and does not go into standby mode.

While the device is busy reading:

- the Chip Enable input should be held Low during the whole busy time (t_{BLBH1}) for devices that do not feature the Chip Enable don't care option. Otherwise, the read operation in progress is interrupted and the device goes into standby mode.
- for devices that feature the Chip Enable don't care option, the Chip Enable going High during the busy time (t_{BLBH1}) will not interrupt the read operation and the device will not go into standby mode.

3.6 Read Enable (\overline{R})

The Read Enable, \overline{R} , controls the sequential data output during read operations. Data is valid t_{RLQV} after the falling edge of \overline{R} . The falling edge of \overline{R} also increments the internal column address counter by one.

3.7 Write Enable (\overline{W})

The Write Enable input, \overline{W} , controls writing to the command interface, input address and data latches. Both addresses and data are latched on the rising edge of Write Enable.

During power-up and power-down a recovery time of 10 μ s (min) is required before the command interface is ready to accept a command. It is recommended to keep Write Enable High during the recovery time.

3.8 Write Protect (\overline{WP})

The Write Protect pin is an input that gives a hardware protection against unwanted program or erase operations. When Write Protect is Low, V_{IL} , the device does not accept any program or erase operations.

It is recommended to keep the Write Protect pin Low, V_{IL} , during power-up and power-down.

3.9 Ready/Busy (\overline{RB})

The Ready/Busy output, \overline{RB} , is an open-drain output that can be used to identify if the P/E/R controller is currently active.

When Ready/Busy is Low, V_{OL} , a read, program or erase operation is in progress. When the operation completes Ready/Busy goes High, V_{OH} .

The use of an open-drain output allows the Ready/Busy pins from several memories to be connected to a single pull-up resistor. A Low will then indicate that one, or more, of the memories is busy.

During power-up and power-down a recovery time of 10 μ s (min) is required before the command interface is ready to accept a command. During the recovery time the \overline{RB} signal is Low, V_{OL} .

Refer to the [Section 10.1: Ready/Busy signal electrical characteristics](#) for details on how to calculate the value of the pull-up resistor.

3.10 V_{DD} supply voltage

V_{DD} provides the power supply to the internal core of the memory device. It is the main power supply for all operations (read, program and erase).

An internal voltage detector disables all functions whenever V_{DD} is below the V_{LKO} threshold (see [Figure 34: Data protection](#)) to protect the device from any involuntary program/erase operations during power-transitions.

Each device in a system should have V_{DD} decoupled with a 0.1 μ F capacitor. The PCB track widths should be sufficient to carry the required program and erase currents

3.11 V_{SS} ground

Ground, V_{SS} , is the reference for the power supply. It must be connected to the system ground.

4 Bus operations

There are six standard bus operations that control the memory. Each of these is described in this section, see [Table 5: Bus operations](#), for a summary.

4.1 Command input

Command input bus operations are used to give commands to the memory. Command are accepted when Chip Enable is Low, Command Latch Enable is High, Address Latch Enable is Low and Read Enable is High. They are latched on the rising edge of the Write Enable signal.

Only I/O0 to I/O7 are used to input commands.

See [Figure 18](#) and [Table 20](#) for details of the timings requirements.

4.2 Address input

Address input bus operations are used to input the memory address. Four bus cycles are required to input the addresses for the 512-Mbit devices (refer to [Table 6](#) and [Table 7](#), Address Insertion).

The addresses are accepted when Chip Enable is Low, Address Latch Enable is High, Command Latch Enable is Low and Read Enable is High. They are latched on the rising edge of the Write Enable signal. Only I/O0 to I/O7 are used to input addresses.

See [Figure 19](#) and [Table 20](#) for details of the timings requirements.

4.3 Data input

Data input bus operations are used to input the data to be programmed.

Data is accepted only when Chip Enable is Low, Address Latch Enable is Low, Command Latch Enable is Low and Read Enable is High. The data is latched on the rising edge of the Write Enable signal. The data is input sequentially using the Write Enable signal.

See [Figure 20](#), [Table 20](#), and [Table 21](#) for details of the timings requirements.

4.4 Data output

Data Output bus operations are used to read: the data in the memory array, the status register, the electronic signature and the serial number.

Data is output when Chip Enable is Low, Write Enable is High, Address Latch Enable is Low, and Command Latch Enable is Low.

The data is output sequentially using the Read Enable signal.

See [Figure 21](#) and [Table 21](#) for details of the timings requirements.

4.5 Write protect

Write protect bus operations are used to protect the memory against program or erase operations. When the Write Protect signal is Low the device will not accept program or erase operations and so the contents of the memory array cannot be altered. The Write Protect signal is not latched by Write Enable to ensure protection even during power-up.

4.6 Standby

When Chip Enable is High the memory enters standby mode, the device is deselected, outputs are disabled and power consumption is reduced.

Table 5. Bus operations

Bus operation	\bar{E}	AL	CL	\bar{R}	\bar{W}	\bar{WP}	I/O0 - I/O7	I/O8 - I/O15 ⁽¹⁾
Command input	V _{IL}	V _{IL}	V _{IH}	V _{IH}	Rising	X ⁽²⁾	Command	X
Address input	V _{IL}	V _{IH}	V _{IL}	V _{IH}	Rising	X	Address	X
Data input	V _{IL}	V _{IL}	V _{IL}	V _{IH}	Rising	X	Data input	Data input
Data output	V _{IL}	V _{IL}	V _{IL}	Falling	V _{IH}	X	Data output	Data output
Write protect	X	X	X	X	X	V _{IL}	X	X
Standby	V _{IH}	X	X	X	X	X	X	X

1. Only for x16 devices.
2. \bar{WP} must be V_{IH} when issuing a program or erase command.

Table 6. Address insertion, x8 devices⁽¹⁾⁽²⁾

Bus cycle	I/O7	I/O6	I/O5	I/O4	I/O3	I/O2	I/O1	I/O0
1 st	A7	A6	A5	A4	A3	A2	A1	A0
2 nd	A16	A15	A14	A13	A12	A11	A10	A9
3 rd	A24	A23	A22	A21	A20	A19	A18	A17
4 th	V _{IL}	V _{IL}	V _{IL}	V _{IL}	V _{IL}	V _{IL}	V _{IL}	A25

1. A8 is set Low or High by the 00h or 01h command, see [Section 6.1: Pointer operations](#).
2. Any additional address input cycle is ignored.

Table 7. Address insertion, x16 devices⁽¹⁾⁽²⁾

Bus cycle	I/O8- I/O15	I/O7	I/O6	I/O5	I/O4	I/O3	I/O2	I/O1	I/O0
1 st	X	A7	A6	A5	A4	A3	A2	A1	A0
2 nd	X	A16	A15	A14	A13	A12	A11	A10	A9
3 rd	X	A24	A23	A22	A21	A20	A19	A18	A17
4 th	X	V _{IL}	V _{IL}	V _{IL}	V _{IL}	V _{IL}	V _{IL}	V _{IL}	A25

1. A8 is don't care in x16 devices.
2. Any additional address input cycle is ignored.

Table 8. Address definition

NAND512xxA2D	
Address	Definition
A0 - A7	Column address
A9 - A25	Page address
A9 - A13	Address in block
A14 - A25	Block address
A8	A8 is set Low or High by the 00h or 01h command, and is don't care in x16 devices
A25	Plane address

5 Command set

All bus write operations to the device are interpreted by the command interface. The commands are input on I/O0-I/O7 and are latched on the rising edge of Write Enable when the Command Latch Enable signal is High. Device operations are selected by writing specific commands to the command register. The two-step command sequences for program and erase operations are imposed to maximize data security.

The commands are summarized in [Table 9](#).

Table 9. Commands

Command	Bus write operations ⁽¹⁾⁽²⁾			Command accepted during busy
	1 st cycle	2 nd cycle	3 rd cycle	
Read A	00h	–	–	
Read B ⁽³⁾	01h	–	–	
Read C	50h	–	–	
Read Electronic Signature	90h	–	–	
Read Status Register	70h	–	–	Yes
Page Program	80h	10h	–	
Copy Back Program	00h	8Ah	(10h) ⁽⁴⁾	
Block Erase	60h	D0h	–	
Reset	FFh	–	–	Yes

1. The bus cycles are only shown for issuing the codes. The cycles required to input the addresses or input/output data are not shown.
2. Any undefined command sequence is ignored by the device.
3. The Read B command (code 01h) is not used in x16 devices.
4. The Program Confirm command (code 10h) is no more necessary for NAND512xxA2D devices. It is optional and has been maintained for backward compatibility.

6 Device operations

6.1 Pointer operations

As the NAND flash memories contain two different areas for x16 devices and three different areas for x8 devices (see [Figure 6](#)) the read command codes (00h, 01h, 50h) are used to act as pointers to the different areas of the memory array (they select the most significant column address).

The Read A and Read B commands act as pointers to the main memory area. Their use depends on the bus width of the device.

- In x16 devices the Read A command (00h) sets the pointer to area A (the whole of the main area) that is words 0 to 255.
- In x8 devices the Read A command (00h) sets the pointer to area A (the first half of the main area) that is bytes 0 to 255, and the Read B command (01h) sets the pointer to area B (the second half of the main area) that is bytes 256 to 511.

In both the x8 and x16 devices the Read C command (50h), acts as a pointer to area C (the spare memory area) that is bytes 512 to 527 or words 256 to 263.

Once the Read A and Read C commands have been issued the pointer remains in the respective areas until another pointer code is issued. However, the Read B command is effective for only one operation, once an operation has been executed in area B the pointer returns automatically to area A.

The pointer operations can also be used before a program operation, that is the appropriate code (00h, 01h or 50h) can be issued before the program command 80h is issued (see [Figure 7](#)).

Figure 6. Pointer operations

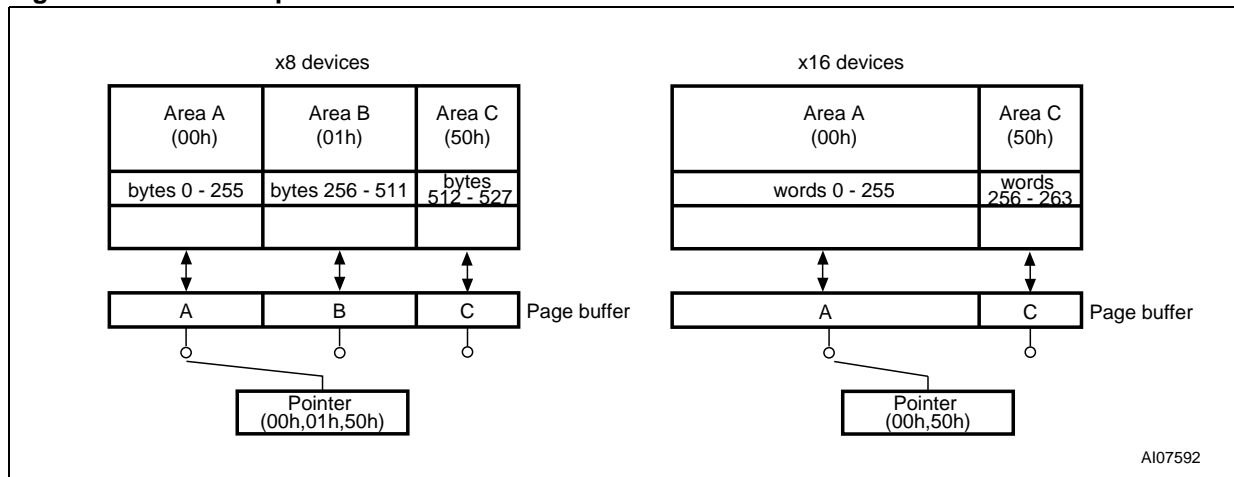
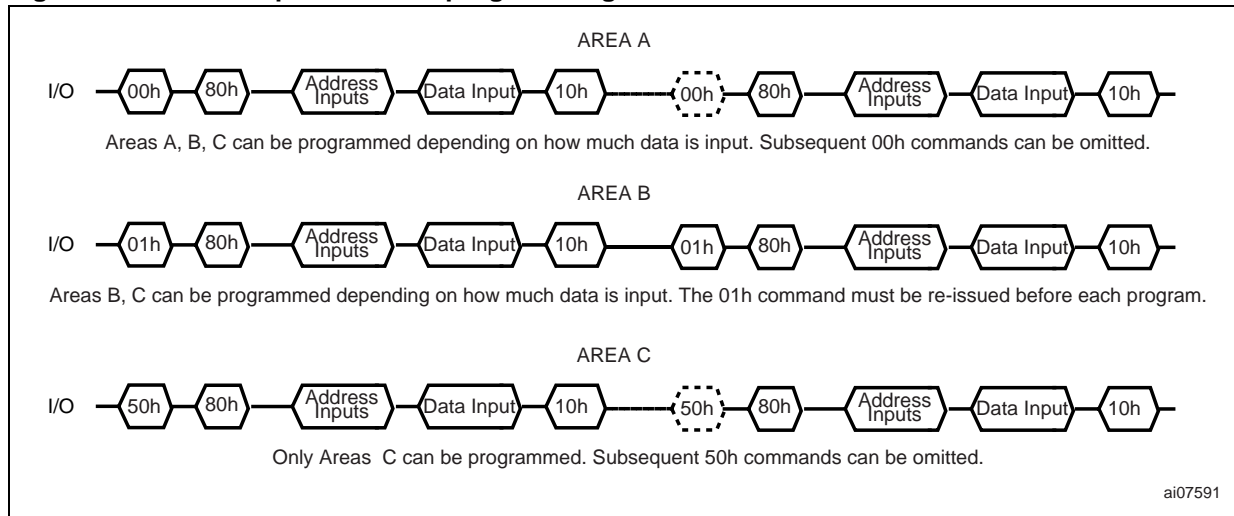

Figure 7. Pointer operations for programming



6.2 Read memory array

Each operation to read the memory area starts with a pointer operation as shown in the [Section 6.1: Pointer operations](#). Once the area (main or spare) has been selected using the Read A, Read B or Read C commands, four bus cycles are required to input the address (refer to [Table 6](#) and [Table 7](#)) of the data to be read.

The device defaults to read A mode after power-up or a reset operation.

When reading the spare area addresses:

- A0 to A3 (x8 devices)
- A0 to A2 (x16 devices)

are used to set the start address of the spare area while addresses:

- A4 to A7 (x8 devices)
- A3 to A7 (x16 devices)

are ignored.

Once the Read A or Read C commands have been issued they do not need to be reissued for subsequent read operations as the pointer remains in the respective area. However, the Read B command is effective for only one operation, once an operation has been executed in area B the pointer returns automatically to area A and so another Read B command is required to start another read operation in area B.

Once a Read command is issued two types of operations are available: random read and page read.

6.2.1 Random read

Each time the command is issued the first read is random read.

6.2.2 Page read

After the random read access the page data is transferred to the page buffer in a time of t_{WHBH} (refer to [Table 21](#) for value). Once the transfer is complete the Ready/Busy signal goes High. The data can then be read out sequentially (from selected column address to last column address) by pulsing the Read Enable signal.

Figure 8. Read (A,B,C) operations

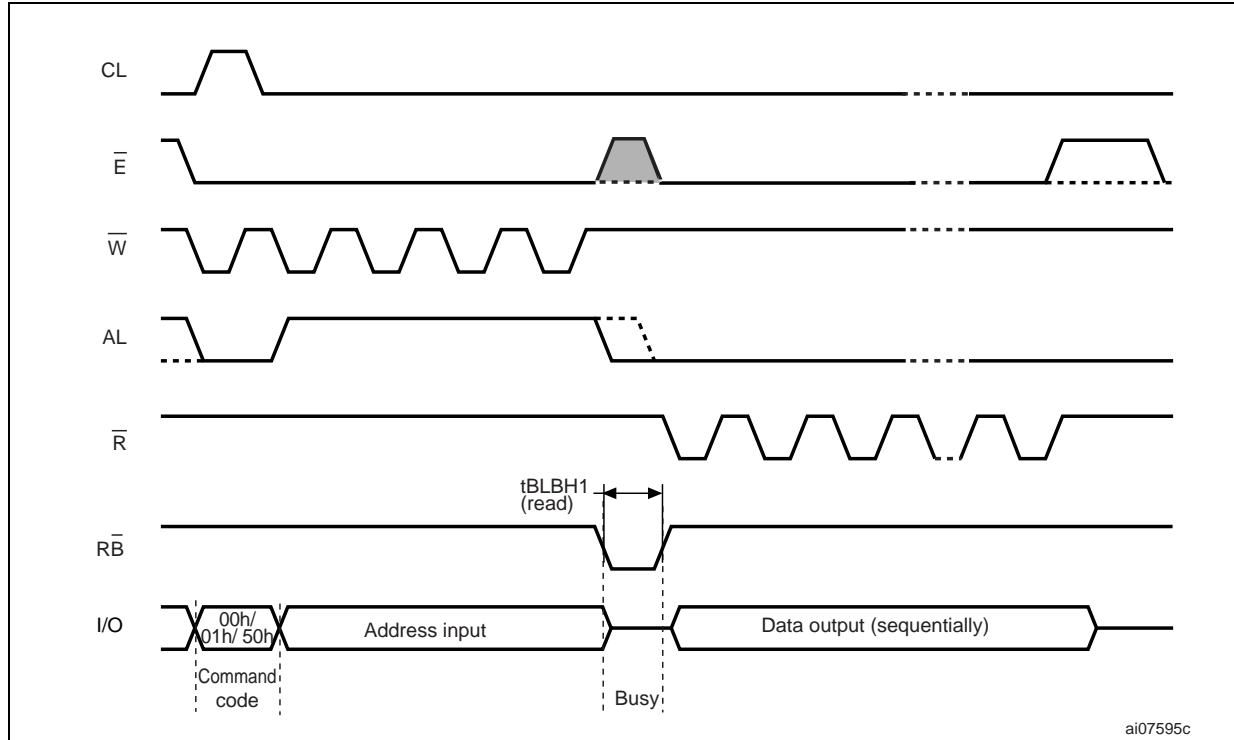

6.2.3 Sequential row read

After the data in last column of the page is output, if the Read Enable signal is pulsed and Chip Enable remains Low, then the next page is automatically loaded into the page buffer and the read operation continues. A sequential row read operation can only be used to read within a block. If the block changes a new read command must be issued. Refer to [Figure 9: Sequential row read operations](#) and [Figure 10: Sequential row read block diagrams](#) for details about sequential row read operations. To terminate a sequential row read operation, set to High the Chip Enable signal for more than t_{EHEL} . Sequential row read is not available when the Chip Enable don't care option is enabled.

Figure 9. Sequential row read operations

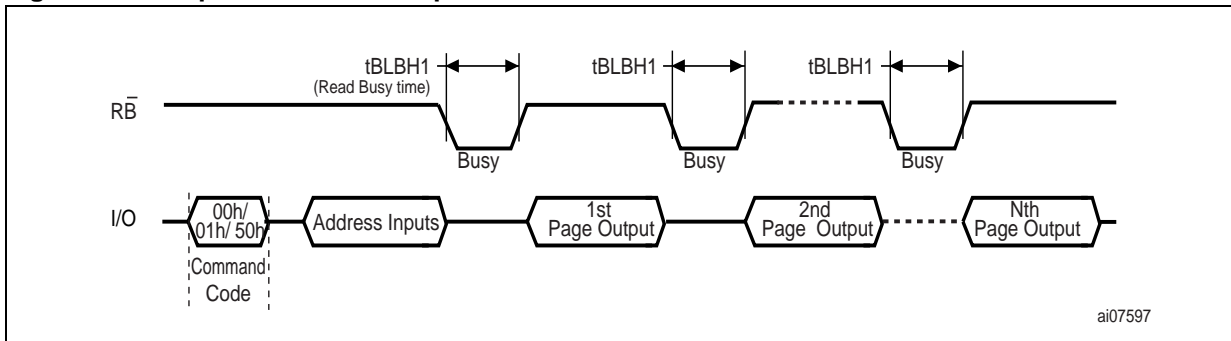

Figure 10. Sequential row read block diagrams

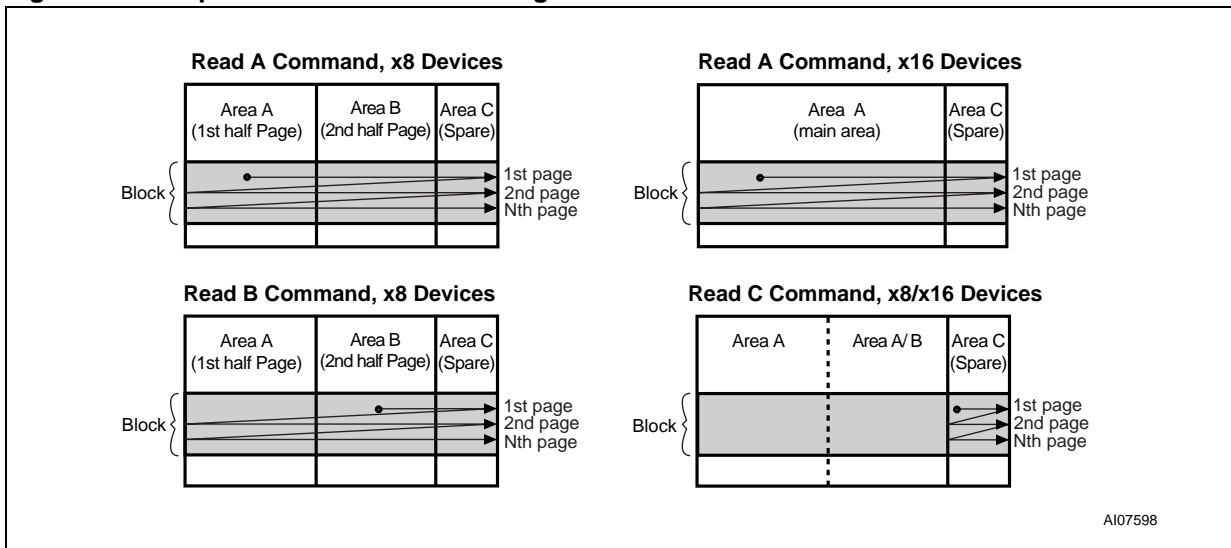
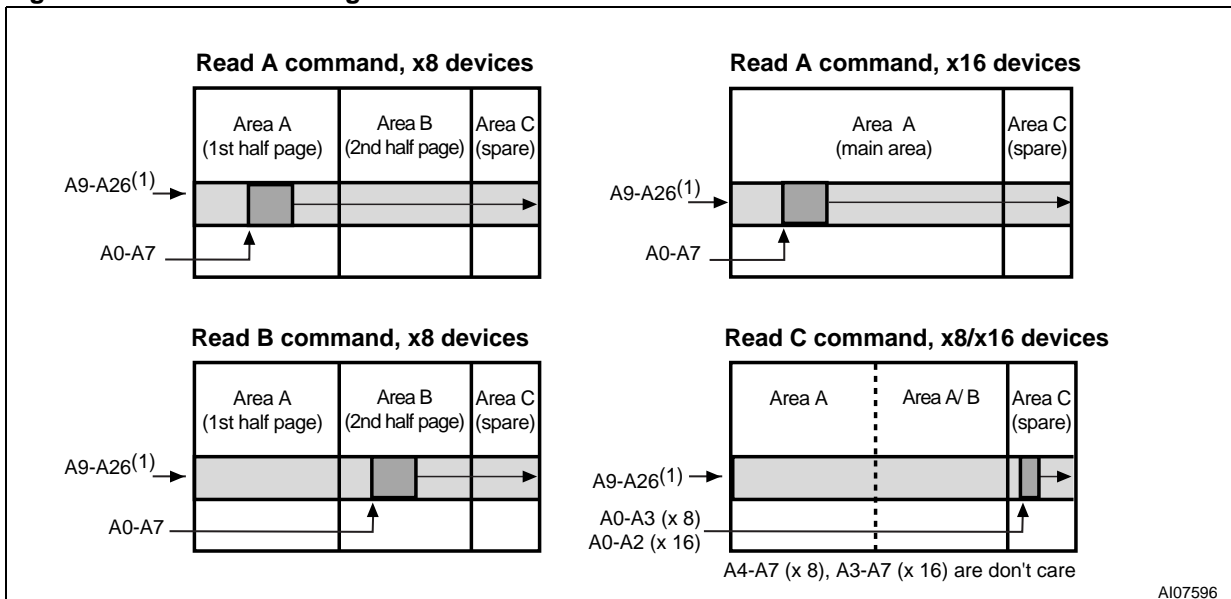

Figure 11. Read block diagrams



1. Highest address depends on device density.

6.3 Page program

The page program operation is the standard operation to program data to the memory array.

The main area of the memory array is programmed by page, however partial page programming is allowed where any number of bytes (1 to 528) or words (1 to 264) can be programmed.

The maximum number of consecutive partial page program operations allowed in the same page is three. After exceeding this a Block Erase command must be issued before any further program operations can take place in that page.

Before starting a page program operation a pointer operation can be performed to point to the area to be programmed. Refer to the [Section 6.1: Pointer operations](#) and [Figure 7](#) for details.

Each page program operation consists of five steps (see [Figure 12](#)):

1. One bus cycle is required to setup the Page Program command
2. Four bus cycles are then required to input the program address (refer to [Table 6](#) and [Table 7](#))
3. The data is then input (up to 528 bytes/264 words) and loaded into the page buffer
4. One bus cycle is required to issue the confirm command to start the P/E/R controller
5. The P/E/R controller then programs the data into the array.

Once the program operation has started the status register can be read using the Read Status Register command. During program operations the status register only flags errors for bits set to '1' that have not been successfully programmed to '0'.

During the program operation, only the Read Status Register and Reset commands are accepted, all other commands are ignored.

Once the program operation has completed the P/E/R controller bit SR6 is set to '1' and the Ready/Busy signal goes High.

The device remains in read status register mode until another valid command is written to the command interface.

Figure 12. Page program operation

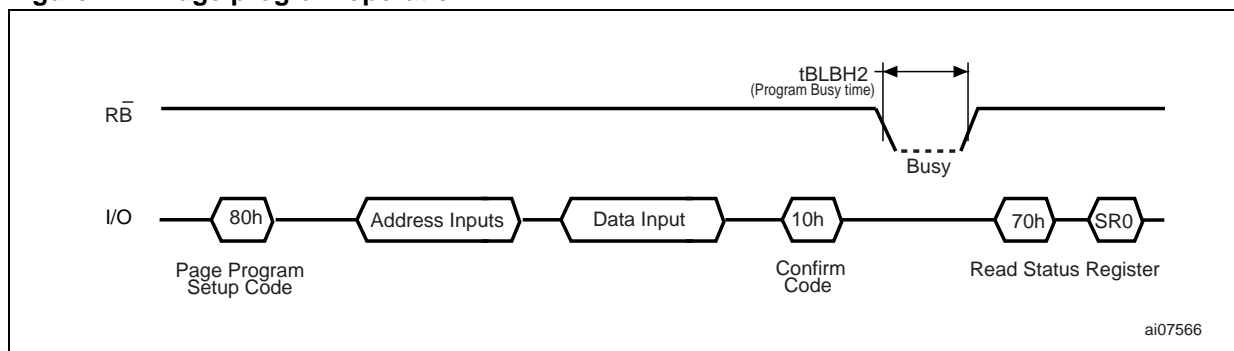

1. Before starting a page program operation a pointer operation can be performed. Refer to [Section 6.1: Pointer operations](#) for details.

6.4 Copy back program

The copy back program operation is used to copy the data stored in one page and reprogram it in another page.

The copy back program operation does not require external memory and so the operation is faster and more efficient because the reading and loading cycles are not required. The operation is particularly useful when a portion of a block is updated and the rest of the block needs to be copied to the newly assigned block.

If the copy back program operation fails an error is signalled in the status register. However as the standard external ECC cannot be used with the copy back operation bit error due to charge loss cannot be detected. For this reason it is recommended to limit the number of copy back operations on the same data and or to improve the performance of the ECC.

The copy back program operation requires three steps:

1. The source page must be read using the Read A command (one bus write cycle to setup the command and then 4 bus write cycles to input the source page address). This operation copies all 264 words/528 bytes from the page into the page buffer
2. When the device returns to the ready state (Ready/Busy High), the second bus write cycle of the command is given with the 4 bus cycles to input the target page address. Refer to [Table 10](#) for the addresses that must be the same for the source and target pages
3. The Program Confirm command (code 10h) is no more necessary on NAND512xxA2D devices. It is optional and has been maintained for backward compatibility.

After a copy back program operation, a partial-page program is not allowed in the target page until the block has been erased.

See [Figure 13](#) for an example of the copy back operation.

Table 10. Copy back program addresses

Density	Same address for source and target pages
512 Mbits	A25

Figure 13. Copy back operation

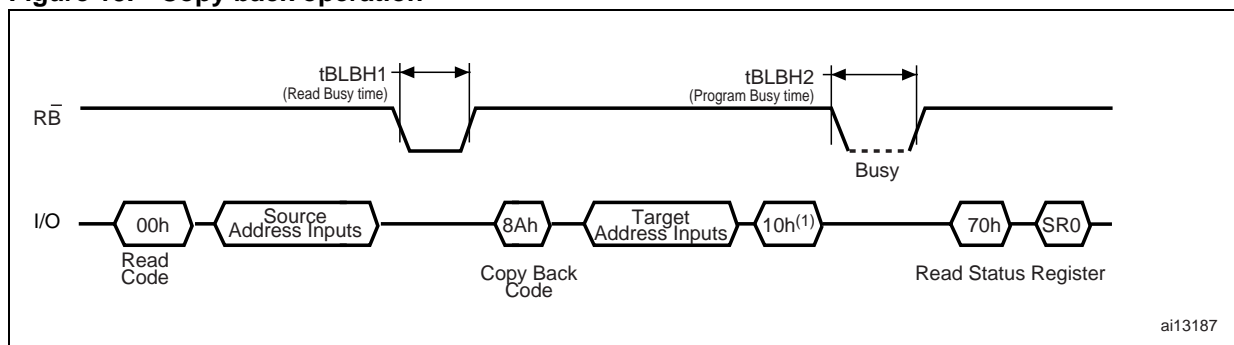

1. The Program Confirm command (code 10h) is no more necessary on NAND512xxA2D devices. It is optional and has been maintained for backward compatibility.

6.5 Block erase

Erase operations are done one block at a time. An erase operation sets all of the bits in the addressed block to '1'. All previous data in the block is lost.

An erase operation consists of three steps (refer to [Figure 14](#)):

1. One bus cycle is required to setup the Block Erase command
2. Only three bus cycles are required to input the block address. The first cycle (A0 to A7) is not required as only addresses A14 to A25 are valid, A9 to A13 are ignored. In the last address cycle I/O2 to I/O7 must be set to V_{IL} .
3. One bus cycle is required to issue the confirm command to start the P/E/R controller.

Once the erase operation has completed the status register can be checked for errors.

Figure 14. Block erase operation

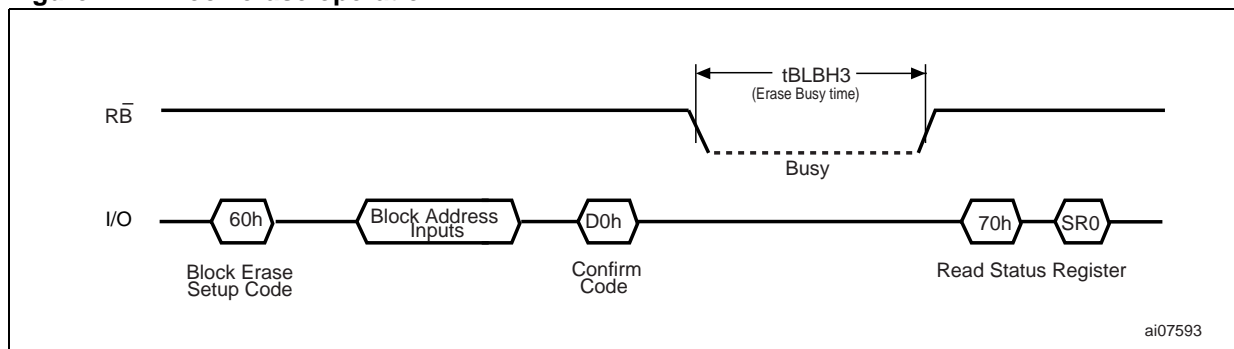

6.6 Reset

The Reset command is used to reset the command interface and status register. If the Reset command is issued during any operation, the operation will be aborted. If it was a program or erase operation that was aborted, the contents of the memory locations being modified will no longer be valid as the data will be partially programmed or erased.

If the device has already been reset then the new Reset command will not be accepted.

The Ready/Busy signal goes Low for t_{BLBH4} after the Reset command is issued. The value of t_{BLBH4} depends on the operation that the device was performing when the command was issued, refer to [Table 21](#) for the values.

6.7 Read status register

The device contains a status register which provides information on the current or previous program or erase operation. The various bits in the status register convey information and errors on the operation.

The status register is read by issuing the Read Status Register command. The status register information is present on the output data bus (I/O0-I/O7) on the falling edge of Chip Enable or Read Enable, whichever occurs last. When several memories are connected in a system, the use of Chip Enable and Read Enable signals allows the system to poll each device separately, even when the Ready/Busy pins are common-wired. It is not necessary to toggle the Chip Enable or Read Enable signals to update the contents of the status register.

After the Read Status Register command has been issued, the device remains in read status register mode until another command is issued. Therefore if a Read Status Register command is issued during a random read cycle a new read command must be issued to continue with a page read.

The status register bits are summarized in [Table 11: Status register bits](#). Refer to [Table 11](#) in conjunction with the following text descriptions.

6.7.1 Write protection bit (SR7)

The write protection bit can be used to identify if the device is protected or not. If the write protection bit is set to '1' the device is not protected and program or erase operations are allowed. If the write protection bit is set to '0' the device is protected and program or erase operations are not allowed.

6.7.2 P/E/R controller bit (SR6)

The program/erase/read controller bit indicates whether the P/E/R controller is active or inactive. When the P/E/R controller bit is set to '0', the P/E/R controller is active (device is busy); when the bit is set to '1', the P/E/R controller is inactive (device is ready).

6.7.3 Error bit (SR0)

The error bit is used to identify if any errors have been detected by the P/E/R controller. The error bit is set to '1' when a program or erase operation has failed to write the correct data to the memory. If the error bit is set to '0' the operation has completed successfully.

6.7.4 SR5, SR4, SR3, SR2 and SR1 are reserved

Table 11. Status register bits

Bit	Name	Logic level	Definition
SR7	Write protection	'1'	Not protected
		'0'	Protected
SR6	Program/ erase/ read controller	'1'	P/E/R C inactive, device ready
		'0'	P/E/R C active, device busy
SR5, SR4, SR3, SR2, SR1	Reserved	Don't care	

Table 11. Status register bits (continued)

Bit	Name	Logic level	Definition
SR0	Generic error	'1'	Error – operation failed
		'0'	No error – operation successful

6.8 Read electronic signature

The device contains a manufacturer code and device code. To read these codes two steps are required:

1. first use one bus write cycle to issue the Read Electronic Signature command (90h), followed by an address input of 00h
2. then perform two bus read operations – the first reads the manufacturer code and the second, the device code. Further bus read operations are ignored.

Refer to [Table 12: Electronic signature](#), for information on the addresses.

Table 12. Electronic signature

Root part number	Manufacturer code	Device code
NAND512R3A2D	20h	36h
NAND512W3A2D		76h
NAND512R4A2D	0020h	0046h
NAND512W4A2D		0056h

7 Software algorithms

This section gives information on the software algorithms that Numonyx recommends to implement to manage the bad blocks and extend the lifetime of the NAND device.

NAND flash memories are programmed and erased by Fowler-Nordheim tunneling using a high voltage. Exposing the device to a high voltage for extended periods can cause the oxide layer to be damaged. For this reason, the number of program and erase cycles is limited (see [Table 14: Program, erase times and program erase endurance cycles](#) for value) and it is recommended to implement garbage collection, a wear-leveling algorithm and an error correction code, to extend the number of program and erase cycles and increase the data retention.

To help integrate a NAND memory into an application Numonyx can provide a full range of software solutions: file system, sector management, drivers, and code management.

Contact the nearest Numonyx sales office or visit www.numonyx.com for more details.

7.1 Bad block management

Devices with bad blocks have the same quality level and the same AC and DC characteristics as devices where all the blocks are valid. A bad block does not affect the performance of valid blocks because it is isolated from the bit line and common source line by a select transistor.

The devices are supplied with all the locations inside valid blocks erased (FFh). The bad block information is written prior to shipping. Any block, where the 6th byte (x8 device)/1st word (x16 device) in the spare area of the 1st page, does not contain FFh is a bad block.

The bad block information must be read before any erase is attempted as the bad block information may be erased. For the system to be able to recognize the bad blocks based on the original information it is recommended to create a bad block table following the flowchart shown in [Figure 15](#).

7.2 NAND flash memory failure modes

Over the lifetime of the device additional bad blocks may develop.

To implement a highly reliable system, all the possible failure modes must be considered:

- Program/erase failure: in this case the block has to be replaced by copying the data to a valid block. These additional bad blocks can be identified as attempts to program or erase them will give errors in the status register.
As the failure of a page program operation does not affect the data in other pages in the same block, the block can be replaced by re-programming the current data and copying the rest of the replaced block to an available valid block. The Copy Back Program command can be used to copy the data to a valid block. See [Section 6.4: Copy back program](#) for more details
- Read failure: in this case, ECC correction must be implemented. To efficiently use the memory space, it is mandatory to recover single-bit errors, which occur during read operations, by using ECC without replacing the whole block.

Refer to [Table 13](#) for the procedure to follow if an error occurs during an operation.

Table 13. NAND flash failure modes

Operation	Procedure
Erase	Block replacement
Program	Block replacement
Read	ECC

Figure 15. Bad block management flowchart

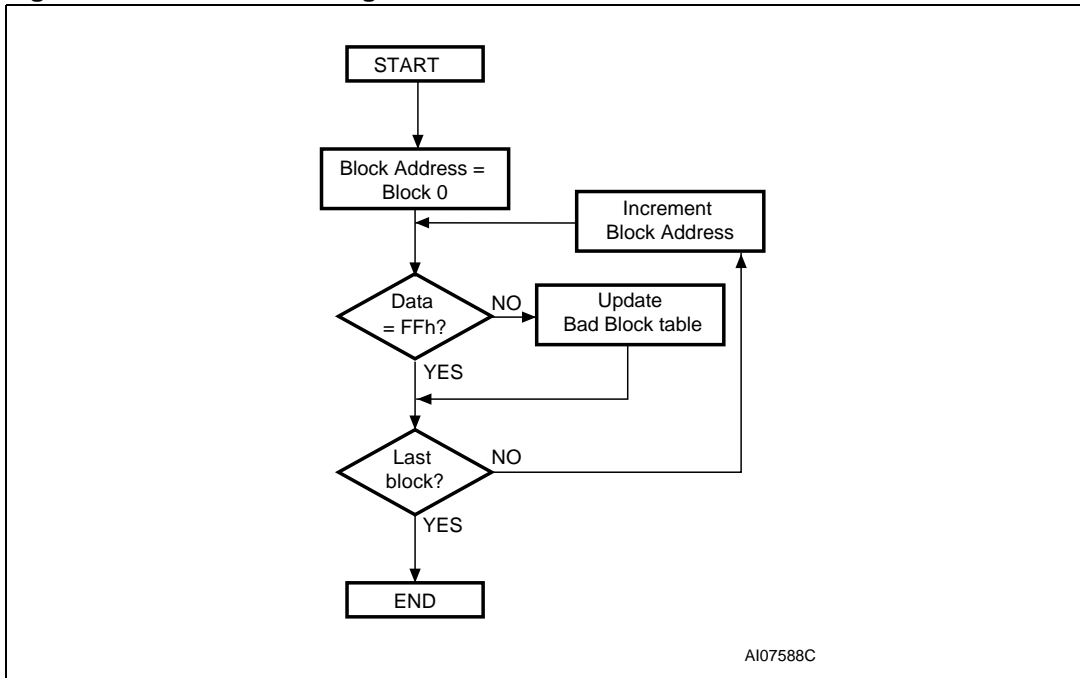

7.3 Garbage collection

When a data page needs to be modified, it is faster to write to the first available page, and the previous page is marked as invalid. After several updates it is necessary to remove invalid pages to free some memory space.

To free this memory space and allow further program operations it is recommended to implement a garbage collection algorithm. In a garbage collection software the valid pages are copied into a free area and the block containing the invalid pages is erased (see [Figure 16](#)).

Figure 16. Garbage collection

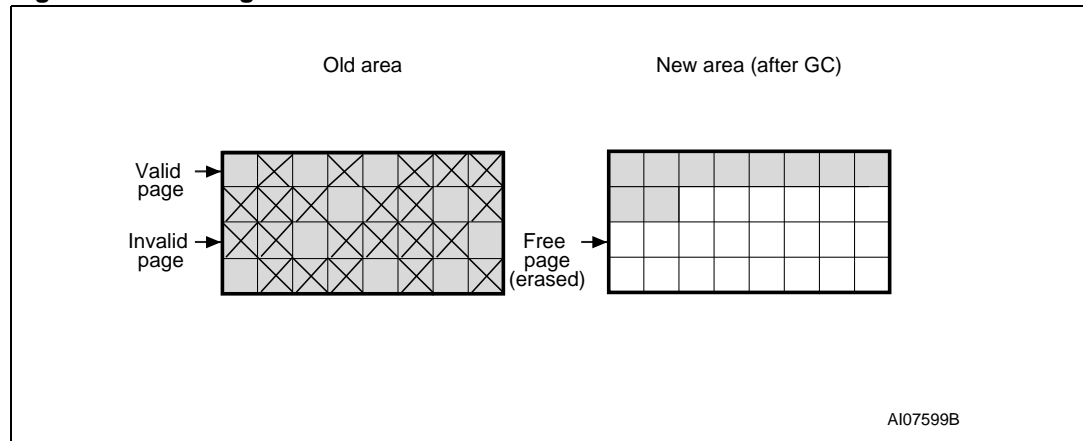

7.4 Wear-leveling algorithm

For write-intensive applications, it is recommended to implement a wear-leveling algorithm to monitor and spread the number of write cycles per block.

In memories that do not use a wear-leveling algorithm not all blocks get used at the same rate.

The wear-leveling algorithm ensures that equal use is made of all the available write cycles for each block. There are two wear-leveling levels:

- First level wear-leveling, new data is programmed to the free blocks that have had the fewest write cycles
- Second level wear-leveling, long-lived data is copied to another block so that the original block can be used for more frequently-changed data.

The second level wear-leveling is triggered when the difference between the maximum and the minimum number of write cycles per block reaches a specific threshold.

7.5 Error correction code

An error correction code (ECC) must be implemented in the NAND flash memories to identify and correct errors in the data.

In this family of devices is required the implementation of an ECC algorithm able to correct 1 bit and to detect 2 bits for every 512 bytes. All the memory array must be covered by ECC, including the spare area, when in this area sensible data are stored.

8 Program and erase times and endurance cycles

The program and erase times and the number of program/erase cycles per block are shown in [Table 14](#).

Table 14. Program, erase times and program erase endurance cycles

Parameters	NAND flash			Unit
	Min	Typ	Max	
Page program time		200	700	µs
Block erase time		1.5	3	ms
Program/erase cycles per block (with ECC)	100,000			cycles
Data retention	10			years

9 Maximum ratings

Stressing the device above the ratings listed in [Table 15: Absolute maximum ratings](#), may cause permanent damage to the device. These are stress ratings only and operation of the device at these or any other conditions above those indicated in the operating sections of this specification is not implied. Exposure to absolute maximum rating conditions for extended periods may affect device reliability.

Table 15. Absolute maximum ratings

Symbol	Parameter	Value		Unit	
		Min	Max		
T _{BIAS}	Temperature under bias	- 50	125	°C	
T _{STG}	Storage temperature	- 65	150	°C	
T _{LEAD}	Lead temperature during soldering		260	°C	
V _{IO} ⁽¹⁾	Input or output voltage	1.8 V devices	- 0.6	2.7	V
		3 V devices	- 0.6	4.6	V
V _{DD}	Supply voltage	1.8 V devices	- 0.6	2.7	V
		3 V devices	- 0.6	4.6	V

1. Minimum Voltage may undershoot to -2 V for less than 20 ns during transitions on input and I/O pins. Maximum voltage may overshoot to V_{DD} + 2 V for less than 20 ns during transitions on I/O pins.

10 DC and AC parameters

This section summarizes the operating and measurement conditions, and the DC and AC characteristics of the device. The parameters in the DC and AC characteristics tables that follow, are derived from tests performed under the measurement conditions summarized in [Table 16: Operating and AC measurement conditions](#). Designers should check that the operating conditions in their circuit match the measurement conditions when relying on the quoted parameters.

Table 16. Operating and AC measurement conditions

Parameter		NAND flash		Units
		Min	Max	
Supply voltage (V_{DD})	1.8 V devices	1.7	1.95	V
	3 V devices	2.7	3.6	V
Ambient temperature (T_A)	Grade 6	-40	85	°C
Load capacitance (C_L) (1 TTL GATE and C_L)	1.8 V devices	30		pF
	3 V devices	50		pF
Input pulses voltages	1.8 V devices	0	V_{DD}	V
	3 V devices	0.4	2.4	V
Input and output timing ref. voltages	1.8 V devices	0.9		V
	3 V devices	1.5		V
Input rise and fall times		5		ns
Output circuit resistors, R_{ref}		8.35		k Ω

Table 17. Capacitance⁽¹⁾⁽²⁾

Symbol	Parameter	Test condition	Typ	Max	Unit
C_{IN}	Input capacitance	$V_{IN} = 0\text{ V}$		10	pF
$C_{I/O}$	Input/output capacitance	$V_{IL} = 0\text{ V}$		10	pF

1. $T_A = 25\text{ °C}$, $f = 1\text{ MHz}$. C_{IN} and $C_{I/O}$ are not 100% tested.
2. Input/output capacitances double on stacked devices.

Table 18. DC characteristics, 1.8 V devices⁽¹⁾

Symbol	Parameter	Test conditions	Min	Typ	Max	Unit
I_{DD1}	Operating current	Sequential read $\bar{E}=V_{IL}, I_{OUT}=0\text{ mA}$	-	8	15	mA
I_{DD2}		Program	-	8	15	mA
I_{DD3}		Erase	-	-	8	15
I_{DD5}	Standby current (CMOS)	$\bar{E}=V_{DD}-0.2,$ $\overline{WP}=0/V_{DD}$	-	10	50	μA
I_{LI}	Input leakage current	$V_{IN}=0\text{ to }V_{DDmax}$	-	-	± 10	μA
I_{LO}	Output leakage current	$V_{OUT}=0\text{ to }V_{DDmax}$	-	-	± 10	μA
V_{IH}	Input high voltage	-	$0.8 \times V_{DD}$	-	$V_{DD} + 0.3$	V
V_{IL}	Input low voltage	-	-0.3	-	$0.2 \times V_{DD}$	V
V_{OH}	Output high voltage level	$I_{OH} = -100\ \mu\text{A}$	$V_{DD}-0.1$	-	-	V
V_{OL}	Output low voltage level	$I_{OL} = 100\ \mu\text{A}$	-	-	0.1	V
$I_{OL} (\overline{RB})$	Output low current (\overline{RB})	$V_{OL} = 0.1\text{ V}$	3	4		mA
V_{LKO}	V_{DD} supply voltage (erase and program lockout)	-	-	1.1	-	V

1. Leakage currents double on stacked devices.

Figure 17. Equivalent testing circuit for AC characteristics measurement

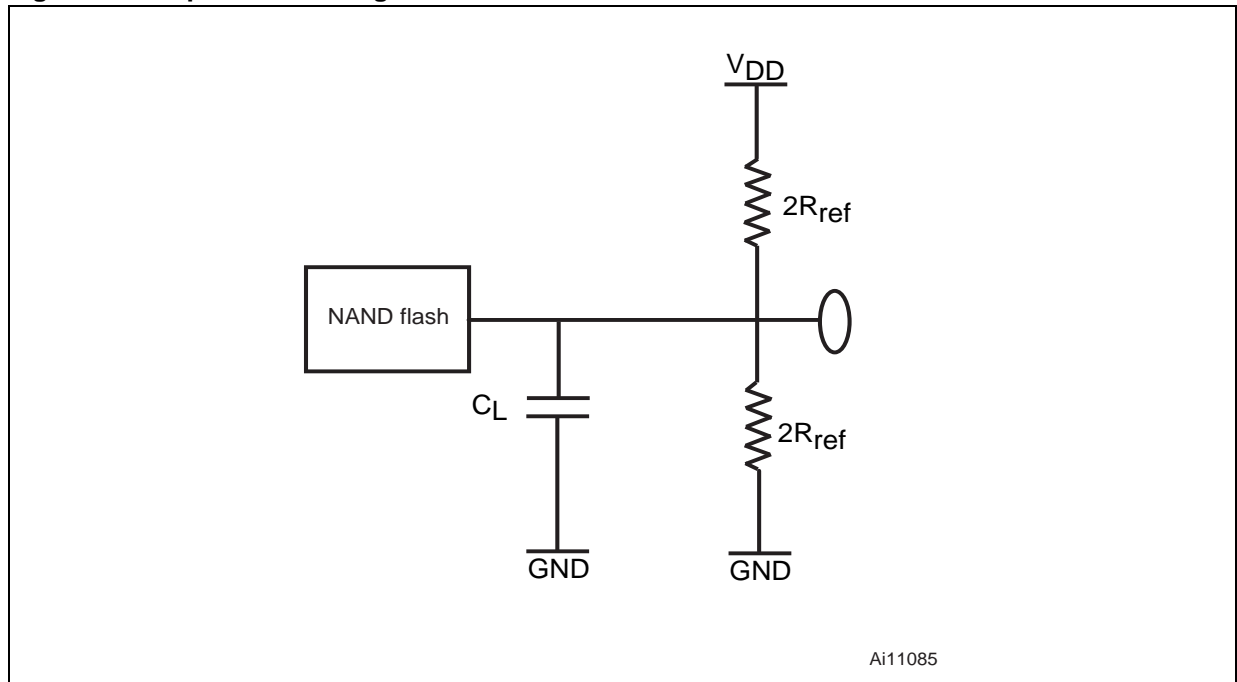

Table 19. DC characteristics, 3 V devices⁽¹⁾

Symbol	Parameter	Test conditions	Min	Typ	Max	Unit	
I _{DD1}	Operating current	Sequential read	t_{RLRL} minimum $\bar{E} = V_{IL}, I_{OUT} = 0$ mA	–	15	30	mA
I _{DD2}		Program	–	–	15	30	mA
I _{DD3}		Erase	–	–	15	30	mA
I _{DD4}	Standby current (TTL),	$\bar{E} = V_{IH}, \bar{WP} = 0V/V_{DD}$	–	–	1	mA	
I _{DD5}	Standby current (CMOS)	$\bar{E} = V_{DD} - 0.2, \bar{WP} = 0V/V_{DD}$	–	10	50	µA	
I _{LI}	Input leakage current	$V_{IN} = 0$ to V_{DDmax}	–	–	±10	µA	
I _{LO}	Output leakage current	$V_{OUT} = 0$ to V_{DDmax}	–	–	±10	µA	
V _{IH}	Input high voltage	–	$0.8 \times V_{DD}$	–	$V_{DD} + 0.3$	V	
V _{IL}	Input low voltage	–	–0.3	–	$0.2 \times V_{DD}$	V	
V _{OH}	Output high voltage level	$I_{OH} = -400$ µA	2.4	–	–	V	
V _{OL}	Output low voltage level	$I_{OL} = 2.1$ mA	–	–	0.4	V	
I _{OL} (R \bar{B})	Output low current (R \bar{B})	$V_{OL} = 0.4$ V	8	10	–	mA	
V _{LKO}	V _{DD} supply voltage (erase and program lockout)	–	–	1.8	–	V	

1. Leakage currents double on stacked devices.

Table 20. AC characteristics for command, address, data input

Symbol	Alt. symbol	Parameter			1.8 V devices	3 V devices	Unit
t _{ALLWH}	t _{ALS}	Address Latch Low to Write Enable High	AL setup time	Min	25	15	ns
t _{ALHWH}		Address Latch High to Write Enable High					
t _{CLHWH}	t _{CLS}	Command Latch High to Write Enable High	CL setup time	Min	25	15	ns
t _{CLLWH}		Command Latch Low to Write Enable High					
t _{DVWH}	t _{DS}	Data Valid to Write Enable High	Data setup time	Min	20	15	ns
t _{ELWH}	t _{CS}	Chip Enable Low to Write Enable High	\bar{E} setup time	Min	30	20	ns
t _{WHALH}	t _{ALH}	Write Enable High to Address Latch High	AL hold time	Min	10	5	ns
t _{WHALL}		Write Enable High to Address Latch Low					
t _{WHCLH}	t _{CLH}	Write Enable High to Command Latch High	CL hold time	Min	10	5	ns
t _{WHCLL}		Write Enable High to Command Latch Low					
t _{WHDX}	t _{DH}	Write Enable High to Data Transition	Data hold time	Min	10	5	ns
t _{WHEH}	t _{CH}	Write Enable High to Chip Enable High	\bar{E} hold time	Min	10	5	ns
t _{WHWL}	t _{WH}	Write Enable High to Write Enable Low	\bar{W} High hold time	Min	15	10	ns
t _{WLWH}	t _{WP}	Write Enable Low to Write Enable High	\bar{W} pulse width	Min	25	15	ns
t _{WLWL}	t _{WC}	Write Enable Low to Write Enable Low	Write cycle time	Min	45	30	ns

Table 21. AC characteristics for operations

Symbol	Alt. symbol	Parameter			1.8 V devices	3 V devices	Unit	
t_{ALLRL1}	t_{AR}	Address Latch Low to Read Enable Low	Read electronic signature	Min	10	10	ns	
t_{ALLRL2}			Read cycle	Min	10	10	ns	
t_{BHRL}	t_{RR}	Ready/Busy High to Read Enable Low			Min	20	20	ns
t_{BLBH1}		Ready/Busy Low to Ready/Busy High	Read busy time	Max	15	12	μ s	
t_{BLBH2}	t_{PROG}		Program busy time	Max	500	500	μ s	
t_{BLBH3}	t_{BERS}		Erase busy time	Max	3	3	ms	
t_{BLBH4}	t_{RST}		Reset busy time, during ready	Max	5	5	μ s	
		Reset busy time, during read	Max	5	5	μ s		
		Reset busy time, during program	Max	10	10	μ s		
		Reset busy time, during erase	Max	500	500	μ s		
t_{CLLRL}	t_{CLR}	Command Latch Low to Read Enable Low			Min	10	10	ns
t_{DZRL}	t_{IR}	Data Hi-Z to Read Enable Low			Min	0	0	ns
t_{EHQZ}	t_{CHZ}	Chip Enable High to Output Hi-Z			Max	20	20	ns
t_{ELQV}	t_{CEA}	Chip Enable Low to Output Valid			Max	45	35	ns
t_{RHRL}	t_{REH}	Read Enable High to Read Enable Low	Read Enable High hold time	Min	15	10	ns	
t_{RHQZ}	t_{RHZ}	Read Enable High to Output Hi-Z			Max	30	30	ns
t_{EHQX}	T_{OH}	Chip Enable High or Read Enable High to Output Hold			Min	10	10	ns
t_{RHQX}								
t_{RLRH}	t_{RP}	Read Enable Low to Read Enable High	Read Enable pulse width	Min	25	15	ns	
t_{RLRL}	t_{RC}	Read Enable Low to Read Enable Low	Read cycle time	Min	50	30	ns	
t_{RLQV}	t_{REA}	Read Enable Low to Output Valid	Read Enable access time	Max	30	18	ns	
			Read ES access time ⁽¹⁾					
t_{WHBH}	t_R	Write Enable High to Ready/Busy High	Read busy time	Max	15	12	μ s	
t_{WHBL}	t_{WB}	Write Enable High to Ready/Busy Low			Max	100	100	ns
t_{WHRL}	t_{WHR}	Write Enable High to Read Enable Low			Min	60	60	ns
t_{VHWH} t_{VLWH} ⁽²⁾	t_{WW}	Write protection time			Min	100	100	ns

1. ES = electronic signature.

2. During a program/erase enable operation, t_{VHWH} is the delay from \overline{WP} High to \overline{W} High. During a program/erase disable operation, t_{VLWH} is the delay from \overline{WP} Low to \overline{W} High.

Figure 18. Command Latch AC waveforms

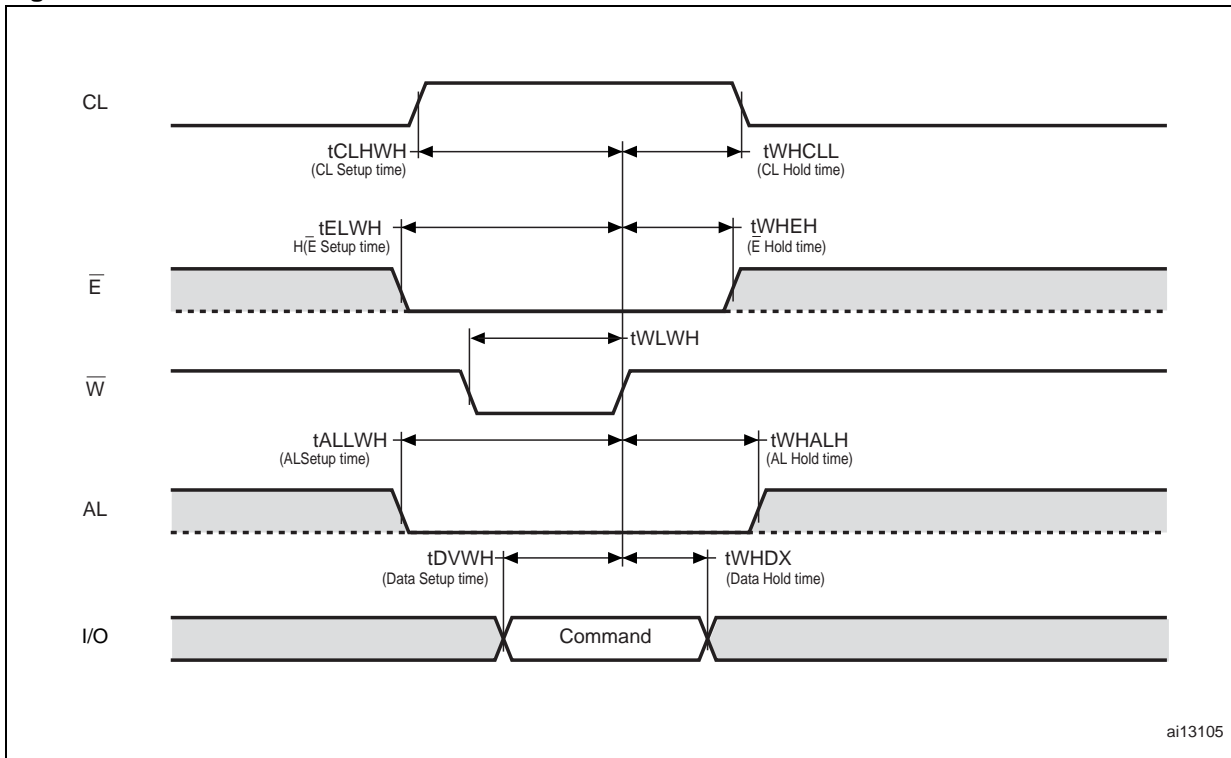

Figure 19. Address Latch AC waveforms

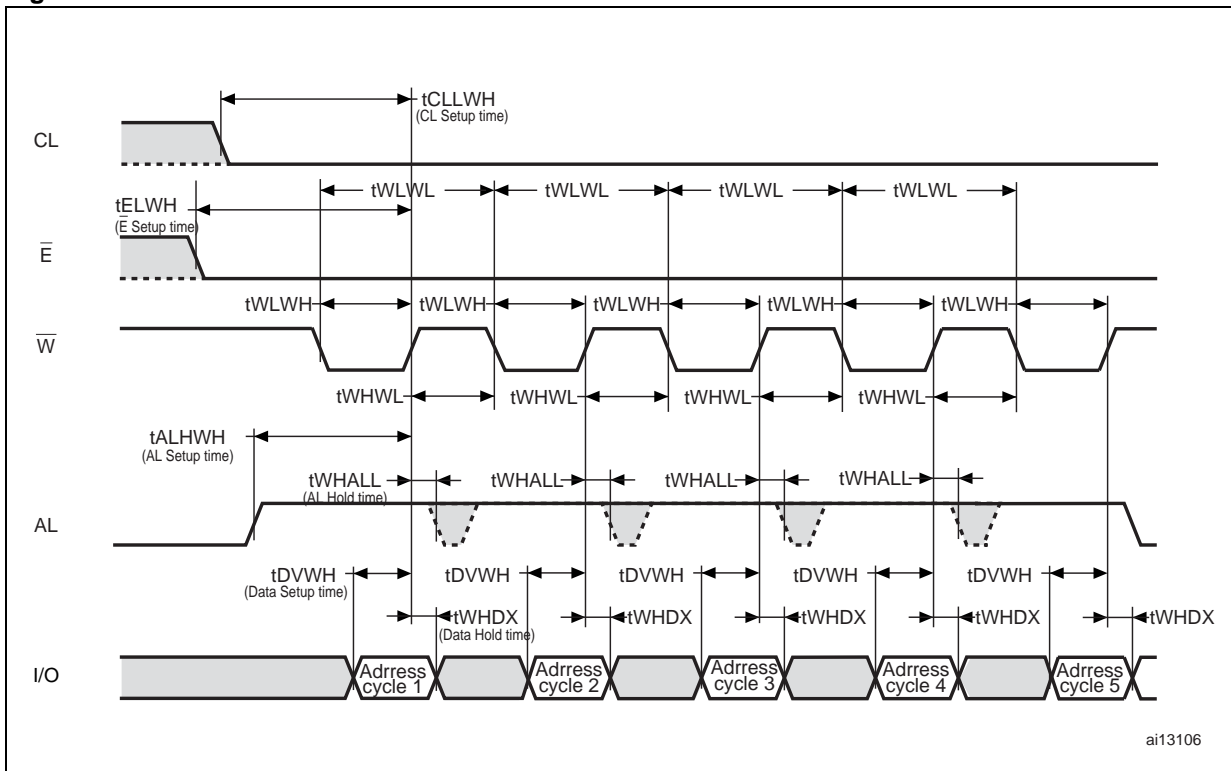
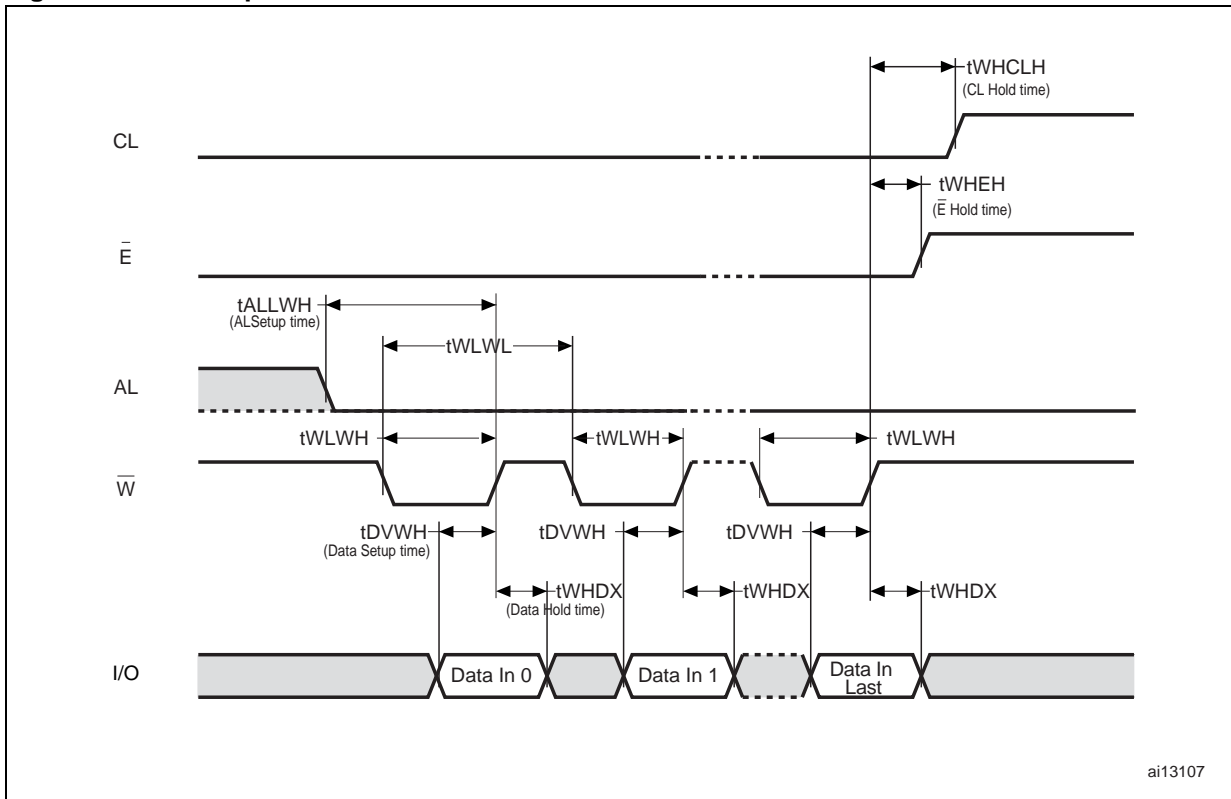
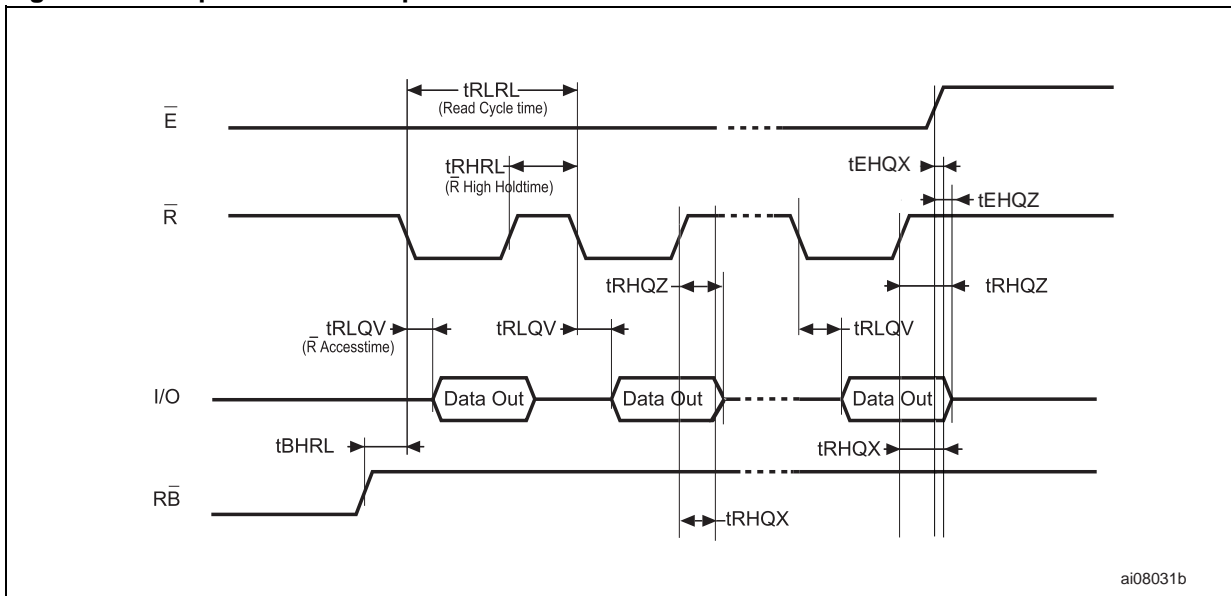

Figure 20. Data Input Latch AC waveforms



ai13107

Figure 21. Sequential data output after read AC waveforms



ai08031b

1. CL = Low, AL = Low, W-bar = High.

Figure 22. Read status register AC waveforms

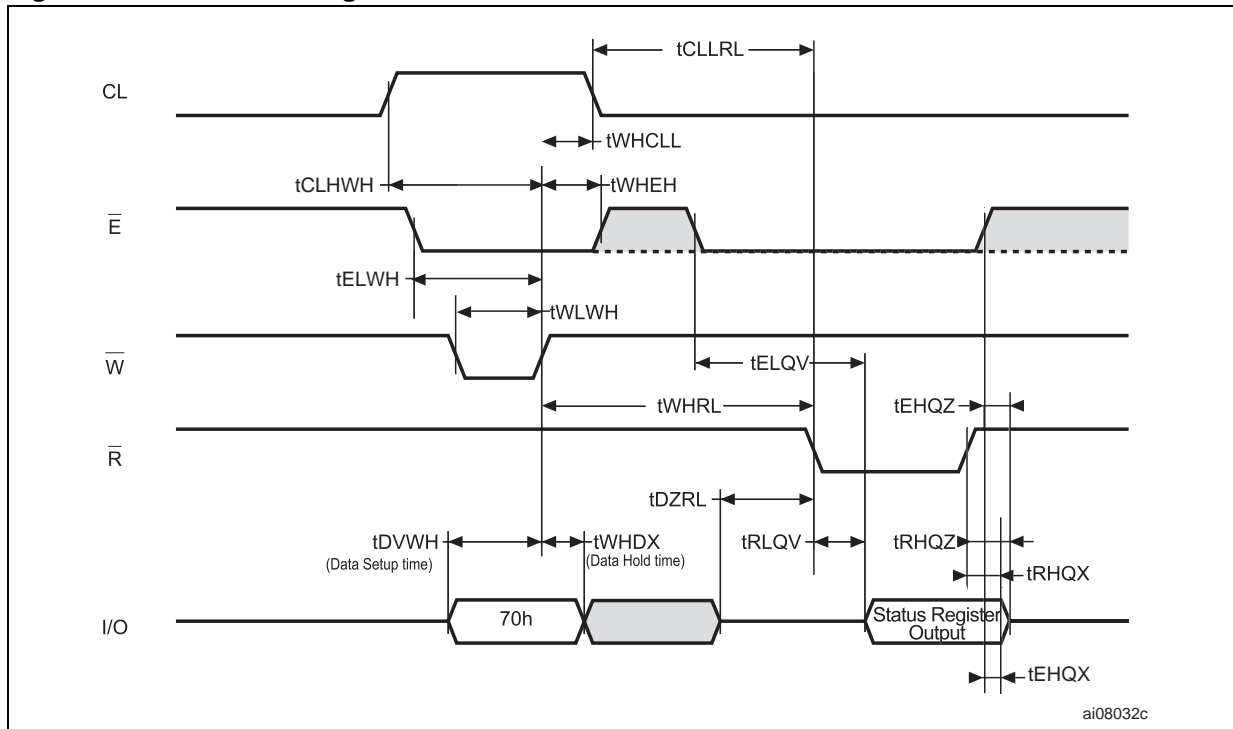
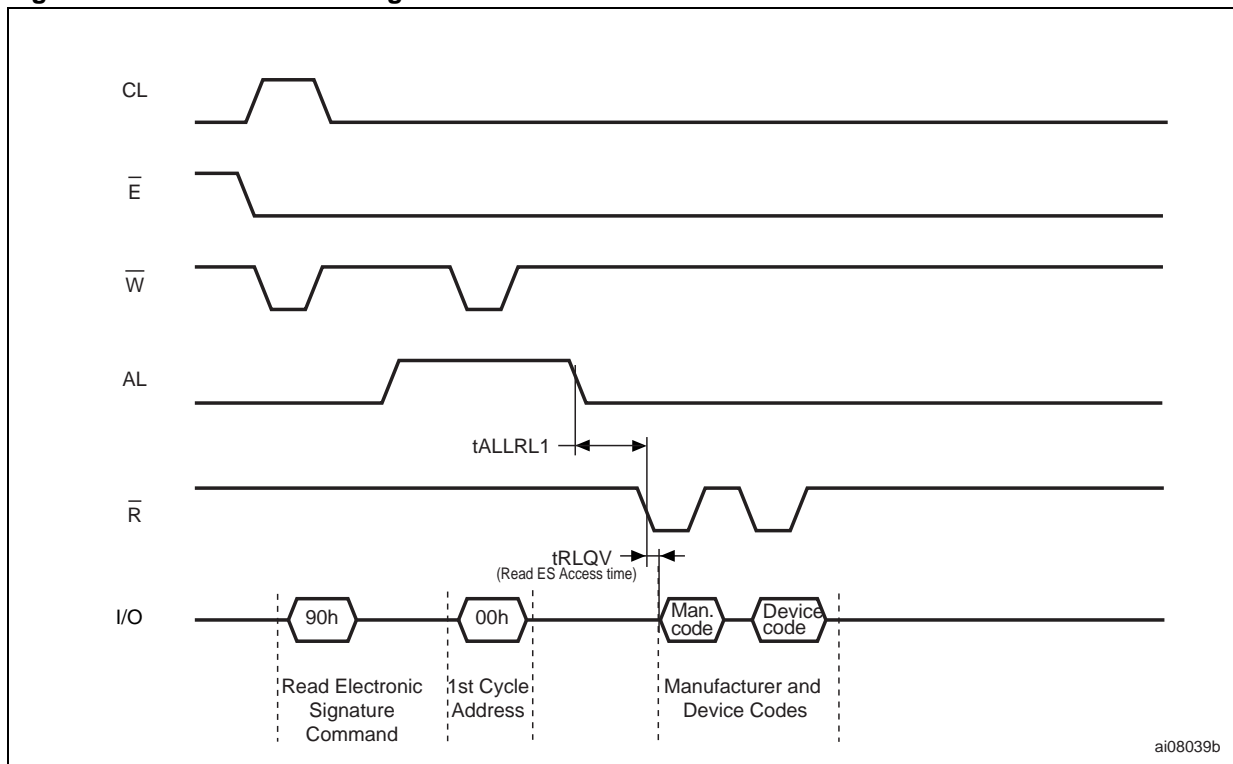

Figure 23. Read electronic signature AC waveforms



1. Refer to [Table 12](#) for the values of the manufacturer and device codes.

Figure 24. Page read A/ read B operation AC waveforms

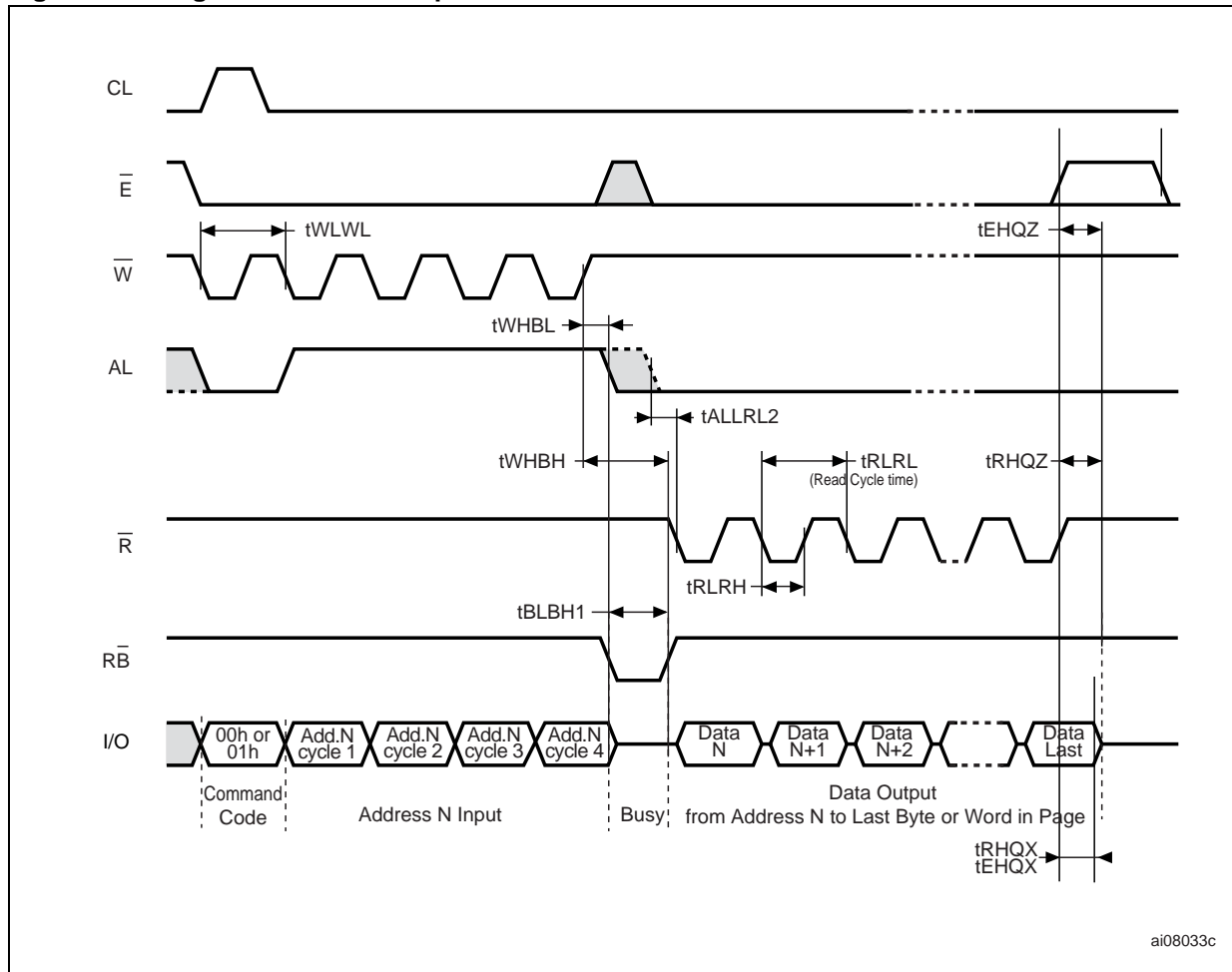
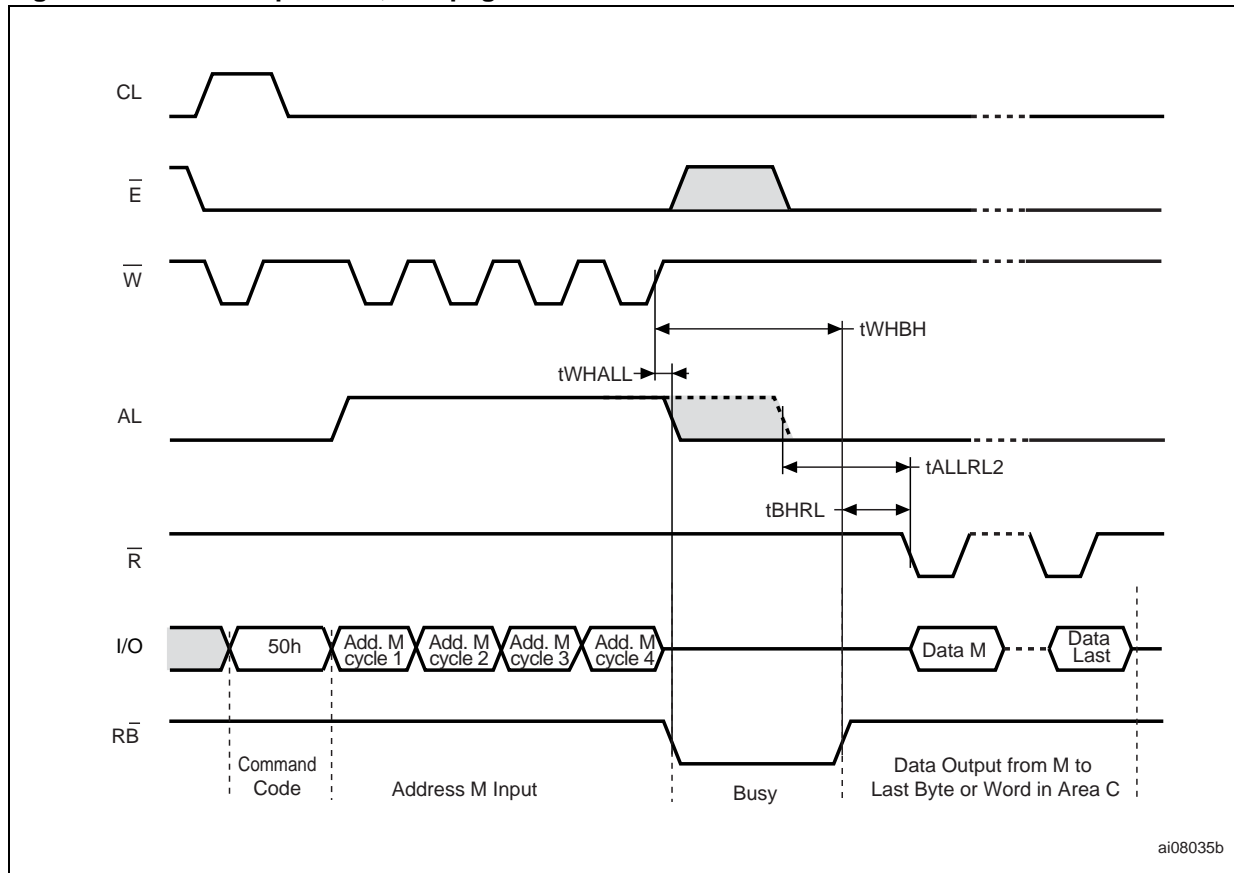

Figure 25. Read C operation, one page AC waveforms



1. A0-A7 is the address in the spare memory area, where A0-A3 are valid and A4-A7 are don't care.

Figure 26. Page program AC waveforms

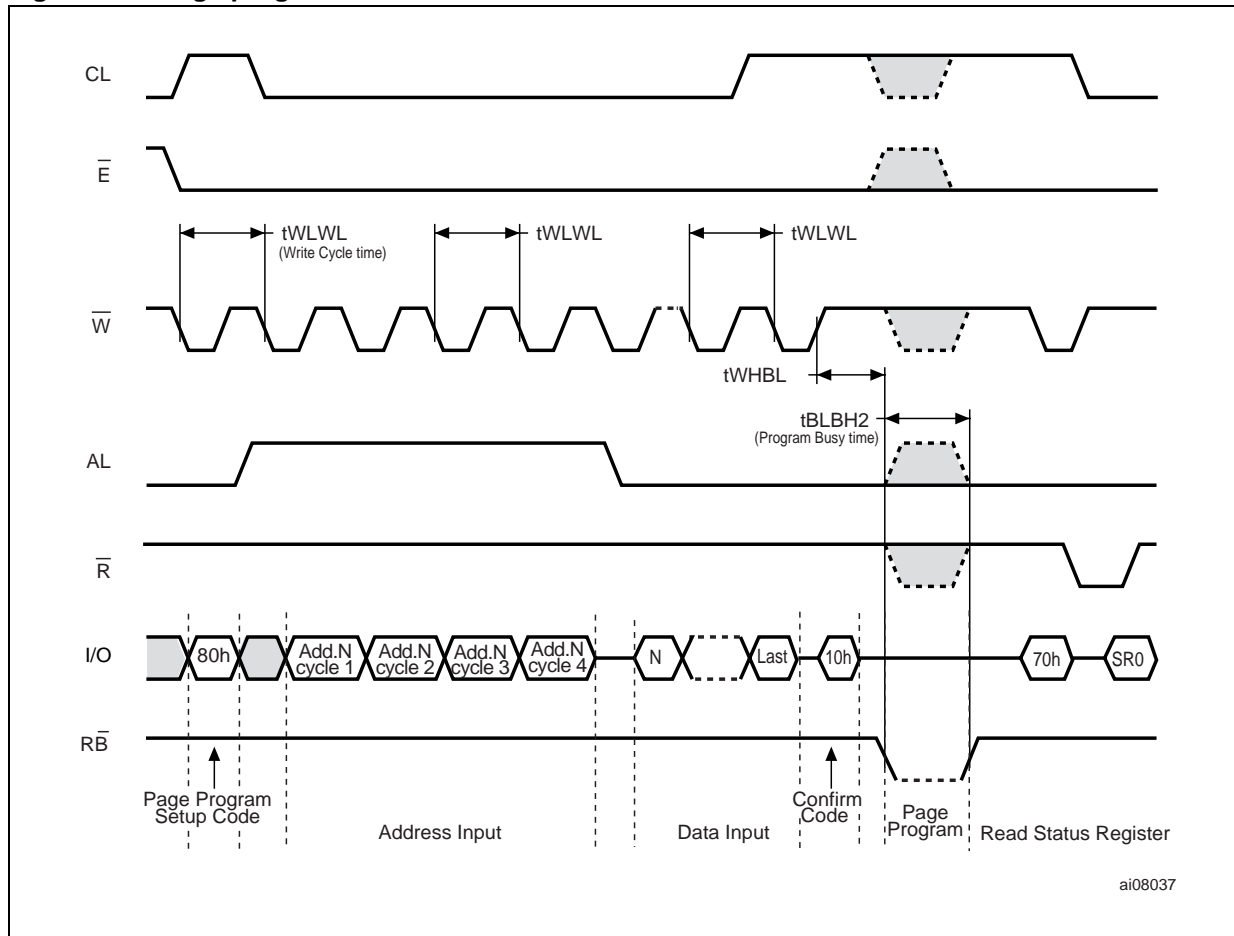

Figure 27. Block erase AC waveforms

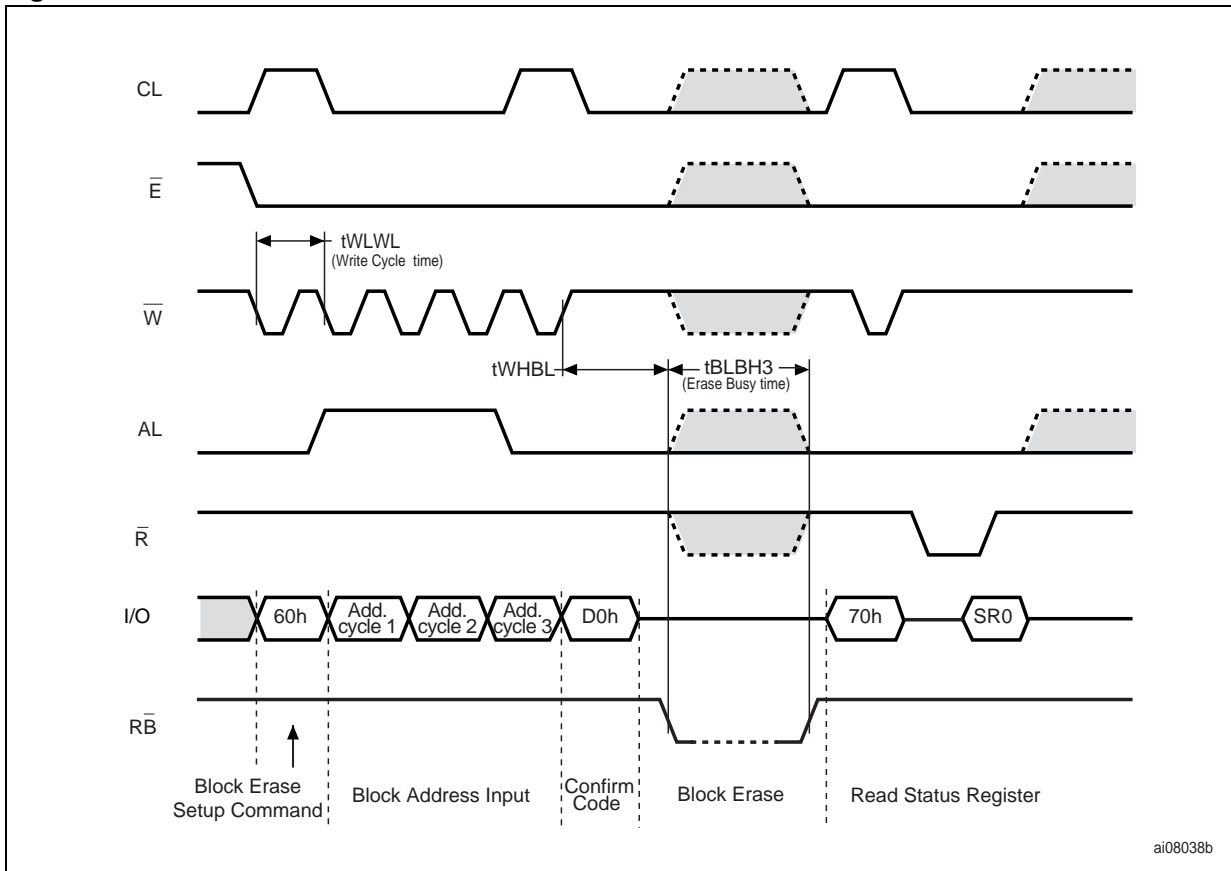

Figure 28. Reset AC waveforms

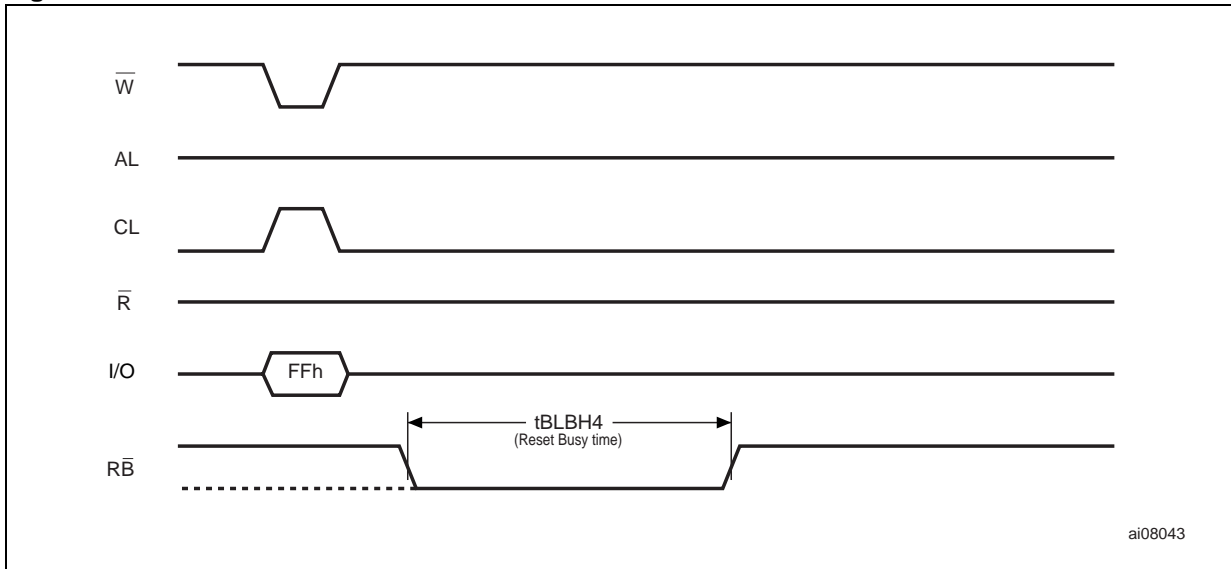

Figure 29. Program/erase enable waveforms

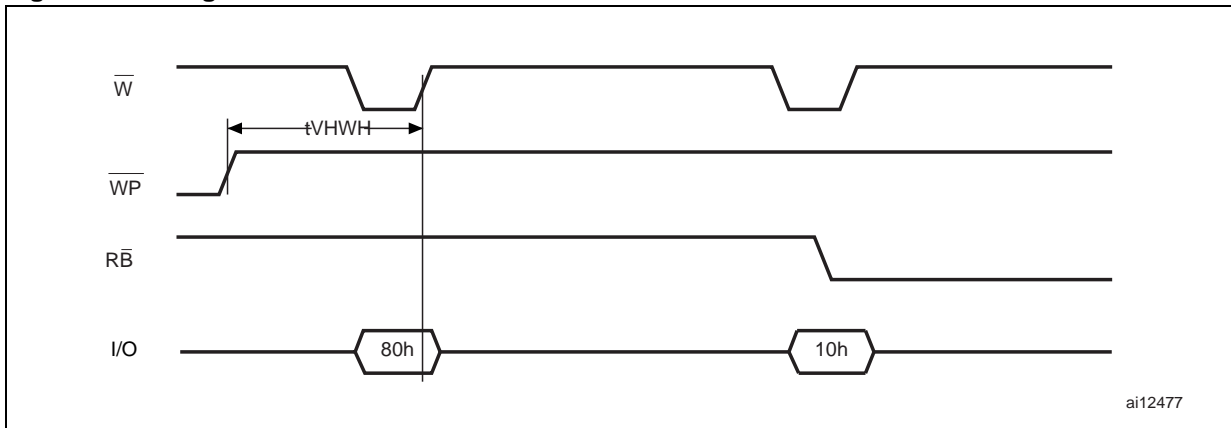
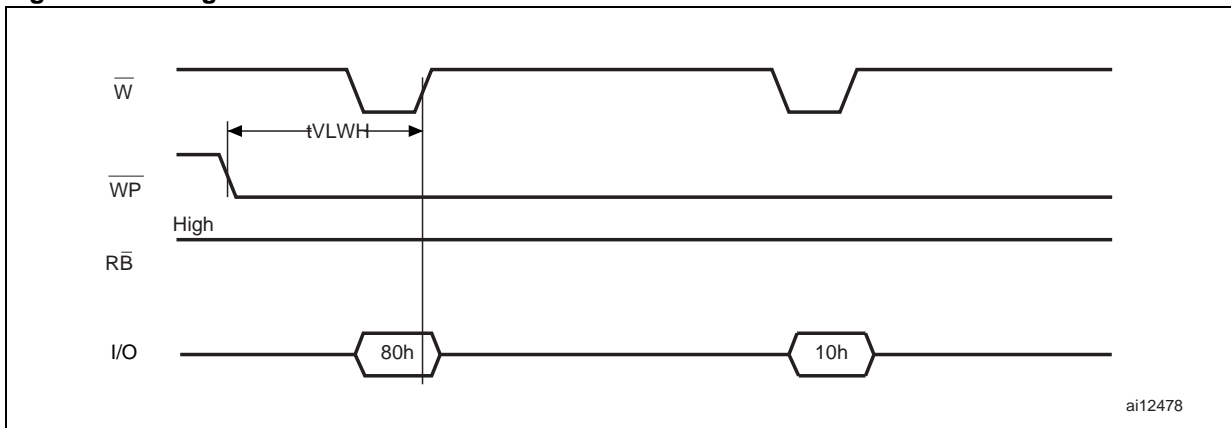

Figure 30. Program/erase disable waveforms



10.1 Ready/Busy signal electrical characteristics

Figure 31, Figure 32 and Figure 33 show the electrical characteristics for the Ready/Busy signal. The value required for the resistor R_P can be calculated using the following equation:

$$R_{Pmin} = \frac{(V_{DDmax} - V_{OLmax})}{I_{OL} + I_L}$$

So,

$$R_{Pmin(1.8V)} = \frac{1.85V}{3mA + I_L}$$

$$R_{Pmin(3V)} = \frac{3.2V}{8mA + I_L}$$

where I_L is the sum of the input currents of all the devices tied to the Ready/Busy signal. R_P max is determined by the maximum value of t_p .

Figure 31. Ready/Busy AC waveform

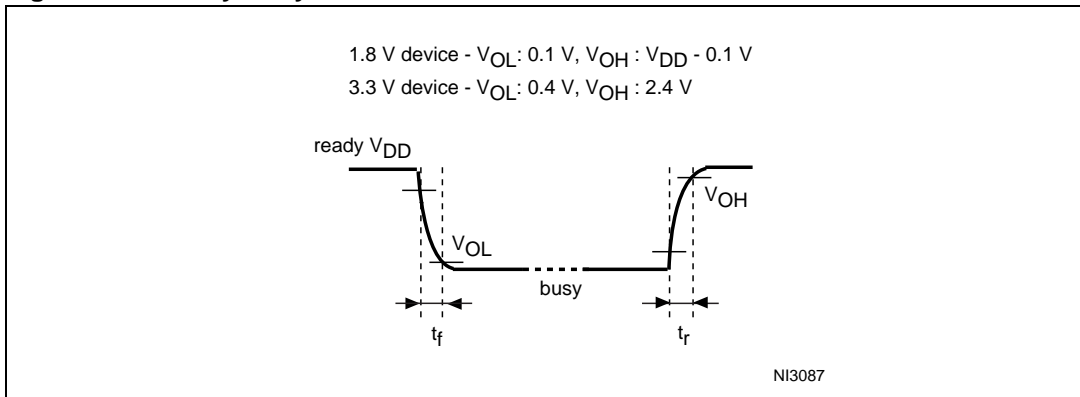

Figure 32. Ready/Busy load circuit

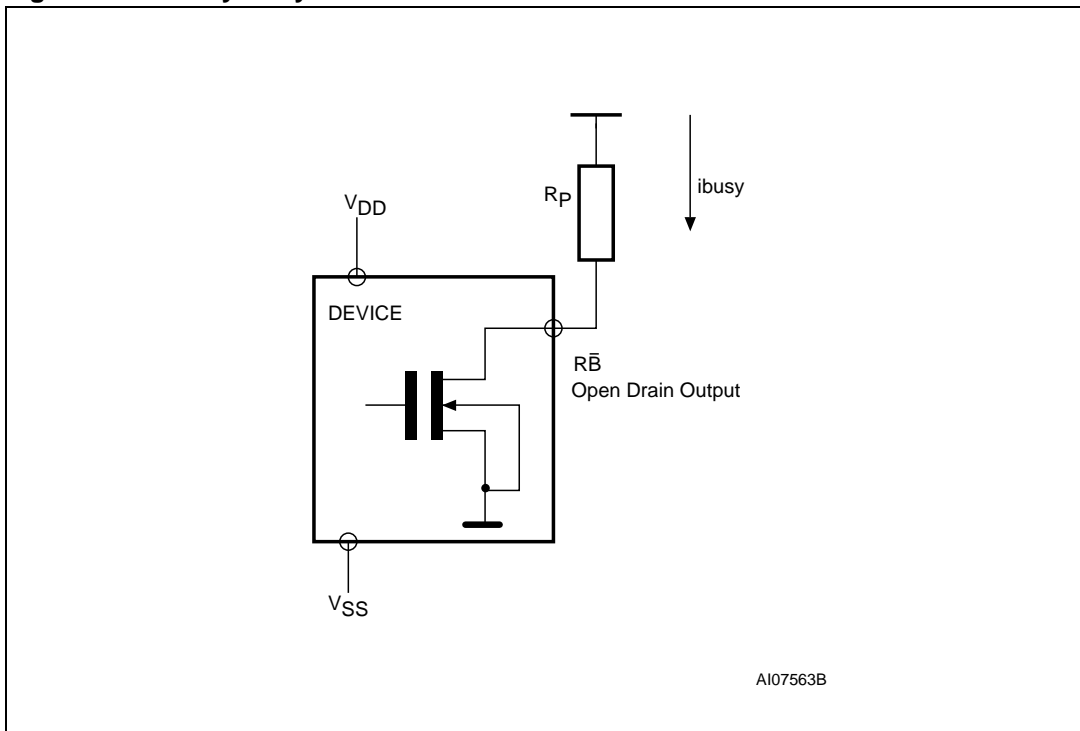
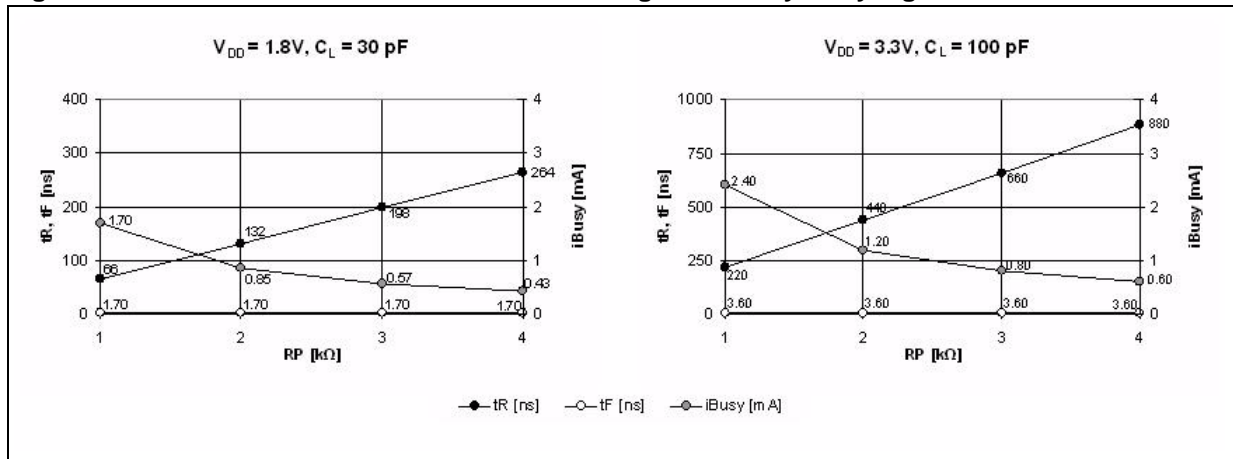

Figure 33. Resistor value versus waveform timings for Ready/Busy signal



1. T = 25 °C.

10.2 Data protection

The Numonyx NAND device is designed to guarantee data protection during power transitions.

A V_{DD} detection circuit disables all NAND operations, if V_{DD} is below the V_{LKO} threshold.

In the V_{DD} range from V_{LKO} to the lower limit of nominal range, the \overline{WP} pin should be kept Low (V_{IL}) to guarantee hardware protection during power transitions as shown in the figure below (Figure 34).

Figure 34. Data protection

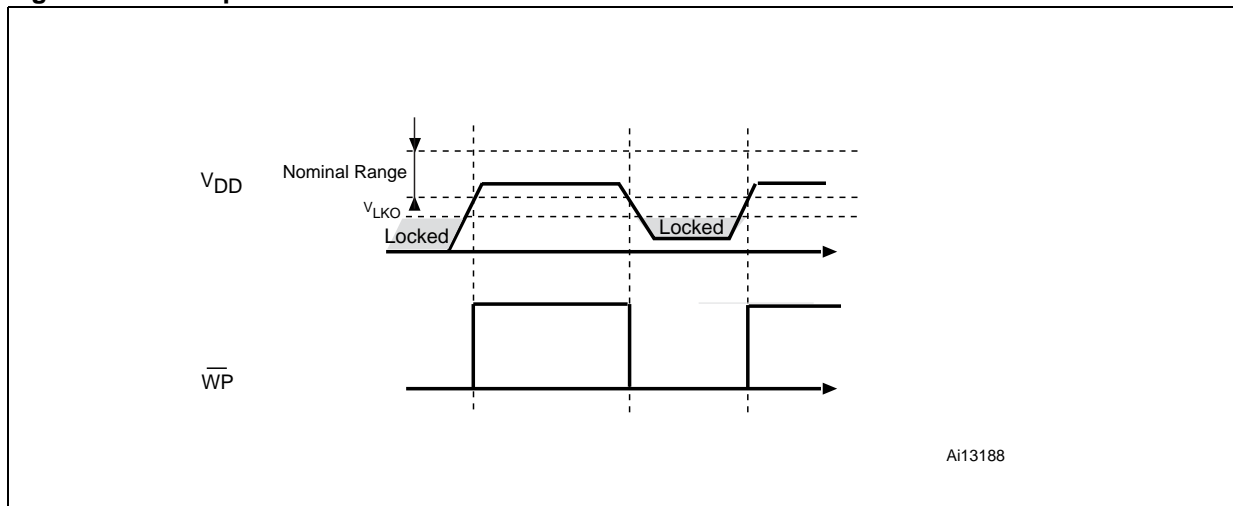

11 Package mechanical

To meet environmental requirements, Numonyx offers these devices in RoHS compliant packages, which have a lead-free second-level interconnect. The category of second-level interconnect is marked on the package and on the inner box label, in compliance with JEDEC Standard JESD97. The maximum ratings related to soldering conditions are also marked on the inner box label.

RoHS compliant specifications are available at www.numonyx.com.

Figure 35. TSOP48 - 48 lead plastic thin small outline, 12 x 20 mm, package outline

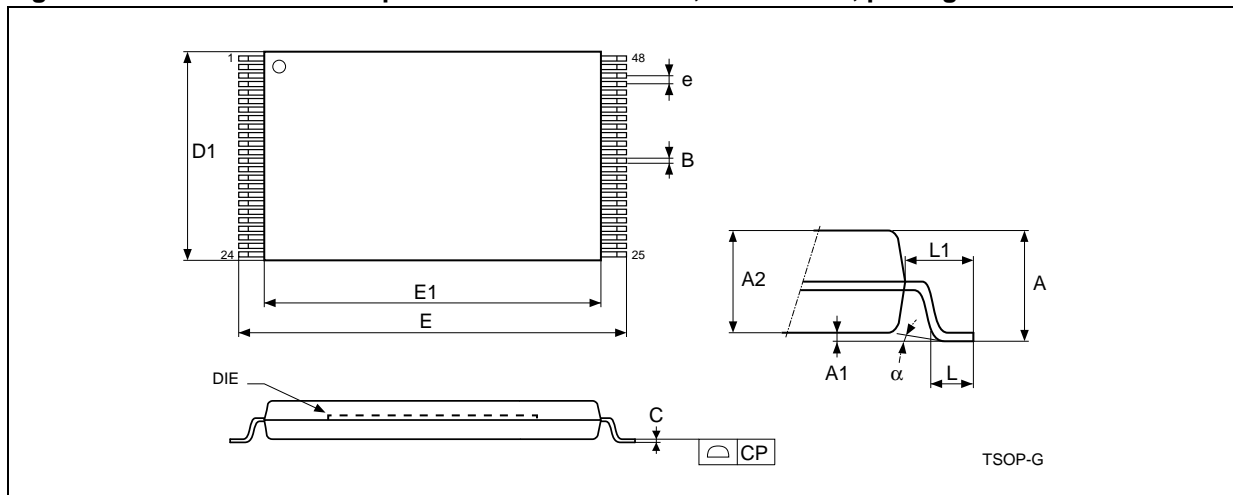

1. Drawing is not to scale.

Table 22. TSOP48 - 48 lead plastic thin small outline, 12 x 20 mm, package mechanical data

Symbol	millimeters			inches		
	Typ	Min	Max	Typ	Min	Max
A			1.20			0.047
A1	0.10	0.05	0.15	0.004	0.002	0.006
A2	1.00	0.95	1.05	0.039	0.037	0.041
B	0.22	0.17	0.27	0.009	0.007	0.011
C		0.10	0.21		0.004	0.008
CP			0.08			0.003
D1	12.00	11.90	12.10	0.472	0.468	0.476
E	20.00	19.80	20.20	0.787	0.779	0.795
E1	18.40	18.30	18.50	0.724	0.720	0.728
e	0.50	–	–	0.020	–	–
L	0.60	0.50	0.70	0.024	0.020	0.028
L1	0.80			0.031		
α	3°	0°	5°	3°	0°	5°

Figure 36. VFBGA63 9 x 11 x 1.05 mm - 6 x 8 +15, 0.80 mm pitch, package outline

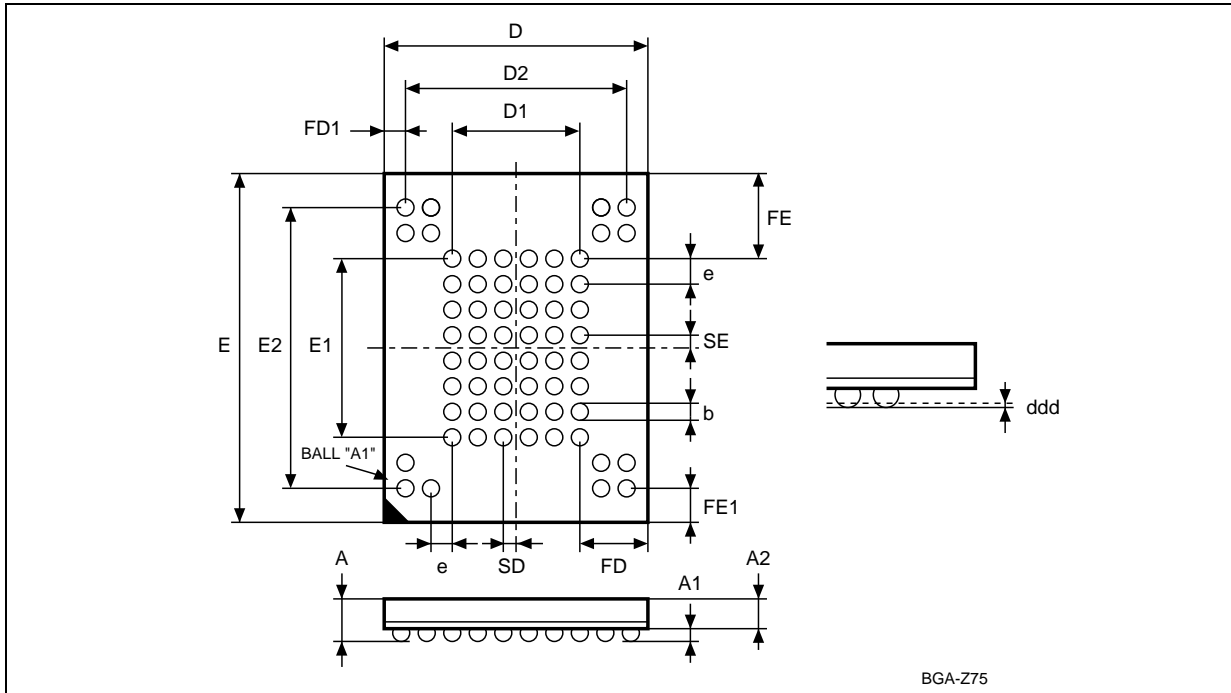

1. Drawing is not to scale.

Table 23. VFBGA63 9 x 11 x 1.05 mm - 6 x 8 +15, 0.80 mm pitch, package mechanical data

Symbol	millimeters			inches		
	Typ	Min	Max	Typ	Min	Max
A			1.05			0.041
A1		0.25			0.010	
A2	0.65			0.026		
b	0.45	0.40	0.50	0.018	0.016	0.020
D	9.00	8.90	9.10	0.354	0.350	0.358
D1	4.00			0.157		
D2	7.20			0.283		
ddd			0.10			0.004
E	11.00	10.90	11.10	0.433	0.429	0.437
E1	5.60			0.220		
E2	8.80			0.346		
e	0.80			0.031		
FD	2.50			0.098		
FD1	0.90			0.035		
FE	2.70			0.106		
FE1	1.10			0.043		
SD	0.40			0.016		
SE	0.40			0.016		

12 Ordering information

Table 24. Ordering information scheme

Example: NAND512W3A

	2	D	N	6	E
Device type NAND = NAND flash memory					
Density 512 = 512 Mbits					
Operating voltage R = $V_{DD} = 1.7$ to 1.95 V W = $V_{DD} = 2.7$ to 3.6 V					
Bus width 3 = x8 4 = x16					
Family identifier A = 528-byte/ 264-word page					
Device options 0 = no option (Chip Enable 'care'; sequential row read enabled) 2 = Chip Enable don't care enabled					
Product version D = fourth version					
Package N = TSOP48 12 x 20 mm ZA = VFBGA63 9 x 11 x 1.05 mm					
Temperature range 6 = -40 to 85 °C					
Option E = RoHS compliant package, standard packing F = RoHS compliant package, tape & reel packing					

Note: Not all combinations are necessarily available. For a list of available devices or for further information on any aspect of these products, please contact your nearest Numonyx sales office.

13 Revision history

Table 25. Document revision history

Date	Revision	Changes
06-Nov-2008	1	Initial release.
10-Feb-2009	2	Document status promoted from target specification to preliminary data. Added root part numbers throughout the document. Modified Figure 31: Ready/Busy AC waveform and Figure 33: Resistor value versus waveform timings for Ready/Busy signal . Removed Figure 17: Error detection. References to ECOPACK removed and replaced by information on RoHS compliance throughout the document.
27-Apr-2009	3	Removed information about the VFBGA55 package and added information about the VFBGA63 package throughout the document.
26-May-2009	4	Re-added information about VFBGA55 package throughout the document and modified dimension A2 of the VFBGA63 package in Table 23: VFBGA63 9 x 11 x 1.05 mm - 6 x 8 +15, 0.80 mm pitch, package mechanical data .
09-Jun-2009	5	Document status promoted from preliminary data to full datasheet.
10-Jul-2009	6	Removed information about the VFBGA55 package throughout the document.
25-Nov-2009	7	Modified: typical and maximum values of I_{DD1} , I_{DD2} and I_{DD3} in Table 18: DC characteristics, 1.8 V devices , t_{CS} minimum value for 1.8 devices in Table 20: AC characteristics for command, address, data input , and maximum value for t_{PROG} in Table 21: AC characteristics for operations .
13-May-2010	8	Removed all the references to 1-Gbit devices.
02-Jul-2010	9	Added Document ID number. Removed sentence : "An ECC model is available in VHDL or Verilog. Contact the nearest Numonyx sales office for more details" from section 7.5. Remove the paragraph 7.6 Hardware simulation models

Please Read Carefully:

INFORMATION IN THIS DOCUMENT IS PROVIDED IN CONNECTION WITH NUMONYX™ PRODUCTS. NO LICENSE, EXPRESS OR IMPLIED, BY ESTOPPEL OR OTHERWISE, TO ANY INTELLECTUAL PROPERTY RIGHTS IS GRANTED BY THIS DOCUMENT. EXCEPT AS PROVIDED IN NUMONYX'S TERMS AND CONDITIONS OF SALE FOR SUCH PRODUCTS, NUMONYX ASSUMES NO LIABILITY WHATSOEVER, AND NUMONYX DISCLAIMS ANY EXPRESS OR IMPLIED WARRANTY, RELATING TO SALE AND/OR USE OF NUMONYX PRODUCTS INCLUDING LIABILITY OR WARRANTIES RELATING TO FITNESS FOR A PARTICULAR PURPOSE, MERCHANTABILITY, OR INFRINGEMENT OF ANY PATENT, COPYRIGHT OR OTHER INTELLECTUAL PROPERTY RIGHT.

Numonyx products are not intended for use in medical, life saving, life sustaining, critical control or safety systems, or in nuclear facility applications.

Numonyx may make changes to specifications and product descriptions at any time, without notice.

Numonyx, B.V. may have patents or pending patent applications, trademarks, copyrights, or other intellectual property rights that relate to the presented subject matter. The furnishing of documents and other materials and information does not provide any license, express or implied, by estoppel or otherwise, to any such patents, trademarks, copyrights, or other intellectual property rights.

Designers must not rely on the absence or characteristics of any features or instructions marked "reserved" or "undefined." Numonyx reserves these for future definition and shall have no responsibility whatsoever for conflicts or incompatibilities arising from future changes to them.

Contact your local Numonyx sales office or your distributor to obtain the latest specifications and before placing your product order.

Copies of documents which have an order number and are referenced in this document, or other Numonyx literature may be obtained by visiting Numonyx's website at <http://www.numonyx.com>.

Numonyx StrataFlash is a trademark or registered trademark of Numonyx or its subsidiaries in the United States and other countries.

*Other names and brands may be claimed as the property of others.

Copyright © 2010, Numonyx B.V. All Rights Reserved.