

NAS 1368

FLIP GROMMET

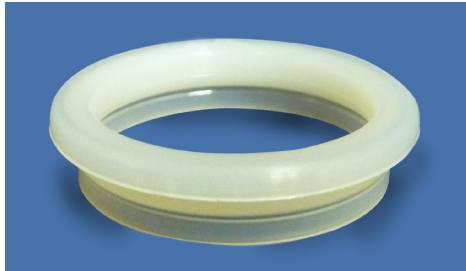

Material:
Nylon 6/6 PER L-P-410
Self-extinguishing without fillers

Color:
Natural

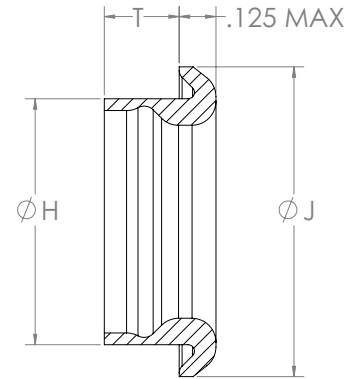
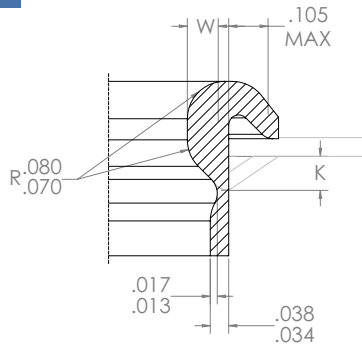
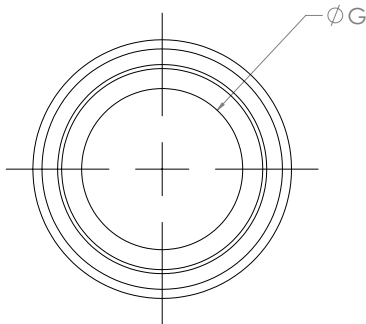

Dash Number	G Dia. Nom.	Structure Hole Dia (Ref) +.010 / -.005	W ±.003	H Dia.		J Dia. ±.005	K Approx.	T Length ±.005								Nom. Wt. # / 1000				
				Min	Max			Length Code												
								A	B	C	D	F	H	K	L					
3	.188	.313	.058	.302	.308	.505	.100										1.1			
4	.250	.375		.364	.370	.567												1.3		
6	.375	.500		.489	.495	.692												1.8		
8	.500	.625		.610	.620	.815		.235	.295	.360	.420	---	---	---	---			2.2		
10	.625	.781	.083	.766	.776	.971												3.0		
12	.750	.906		.891	.901	1.096												3.6		
14	.875	1.031		1.016	1.026	1.221												4.3		
16	1.000	1.188		.104	1.173	1.183		1.378	.120	.275	.335	.400	.460	---	---	---	---		5.7	
18	1.125	1.313			1.298	1.308		1.503												6.4
20	1.250	1.438			1.423	1.433		1.628												7.2
22	1.375	1.563	1.538		1.558	1.748												7.7		
24	1.500	1.688	1.663		1.683	1.873	---	---		---	---	.275	.335	.400	.460			8.3		
28	1.750	1.938	1.913		1.933	2.123												9.7		
32	2.000	2.188	2.163		2.183	2.373												10.7		

Nominal Structure Thickness (Ref.)							
-3 To -18				-20 To -32			
A	B	C	D	F	H	K	L
.025 TO .080	.081 TO .140	.141 TO .200	.201 TO .250	.025 TO .040	.041 TO .091	.092 TO .160	.161 TO .220

