

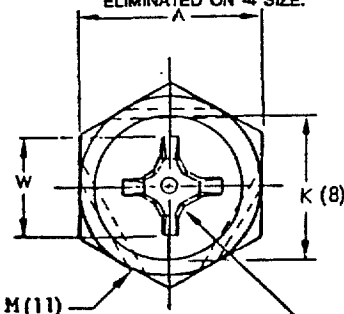

FED SUP CLASS
5305

HEAD MARKING: NAS1801-04, -06, -08, AND 3; MATERIAL CODE (Δ) AND MANUFACTURERS SYMBOL
NAS1801-4, -5 AND -6; BASIC NO., DIAMETER DASH NO., AND MANUFACTURER'S SYMBOL EXCEPT LETTERS "NAS" MAY BE ELIMINATED ON 4 SIZE.



(2) CRUCIFORM RECESS PER MS9006 (6)

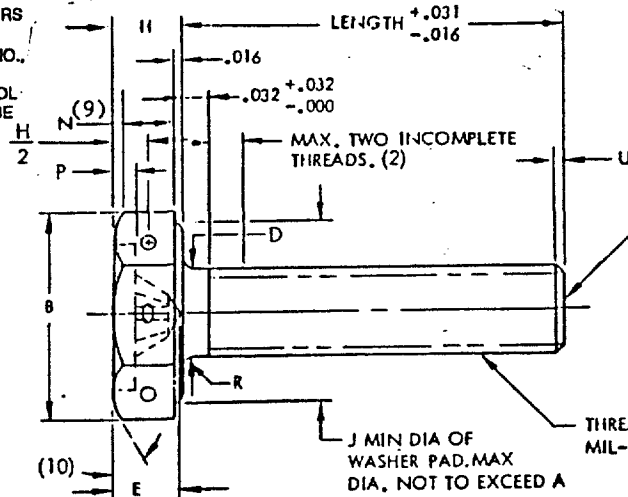

POINT SHALL BE FLAT AND CHAMFERED. CHAMFER PLUS INCOMPLETE THREAD NOT TO EXCEED TWO PITCHES.

THREADS PER MIL-S-8879

FIRST DASH NO	THREAD SIZE	A HEX	B MIN (9)	D DIA	H	J DIA MIN (1)	K (8) REF	M DIA +.010 -.000	N MIN (9)	P (8) REF	R	U REF	W	(5) PEN ETACHION	RECESS SIZE
04	.1120-40 UNJC-3A	.189 .181	.207	.112 .094	.060 .049	.156	.153		.017	.008	.015 .005	.031	.102 .089	.056 .040	1
06	.1380-32 UNJC-3A	.251 .243	.277	.138 .115	.093 .080	.210	.210		.042	.012	.015 .005	.039	.154 .141	.075 .052	2
08	.1640-32 UNJC-3A	.251 .243	.277	.164 .141	.110 .096	.210	.210		.053	.018	.015 .005	.039	.169 .156	.090 .067	2
3	.1900-32 UNJF-3A	.314 .305	.348	.190 .167	.120 .105	.272	.270	.046	.059	.020	.020 .010	.039	.184 .171	.105 .082	2
4	.2500-28 UNJF-3A	.376 .367	.410	.250 .224	.140 .125	.335		.046	.073		.020 .010	.045	.247 .234	.118 .095	3
5	.3125-24 UNJF-3A	.439 .429	.480	.312 .282	.171 .156	.398		.070	.102		.020 .010	.052	.317 .304	.148 .126	4
6	.3750-24 UNJF-3A	.502 .492	.552	.375 .345	.203 .188	.460		.070	.131		.025 .015	.052	.342 .329	.173 .151	4

(2) MATERIAL: ALLOY STEEL 4340 (UNS G43400) PER MIL-S-5000, 8740 (UNS G87400) PER MIL-S-6049 OR AMS6322.
HEAT TREAT: 160 to 180 KSI tensile strength.
FINISH: Cadmium plate per QQ-P-416, type II, class 2.
CODE: First dash number indicates diameter; second dash number indicates length in .0625 inch increments. No letter after first dash number indicates undrilled head. Letter "D" after first dash number indicates drilled head (-3 thru -6 sizes only).
EXAMPLE OF PART NUMBERS: NAS1801-4-16 .2500-28 UNJF-3A screw, one inch long.
NAS1801-04-17 .1120-40 UNJC-3A screw, .750 inch long.
NAS1801-4D16 .2500-28 UNJF-3A screw, one inch long, drilled head.

- NOTES: (1) Concentricity: "J" diameter to thread pitch diameter within .005 TIR.
(2) Complete thread length for screws longer than 2 inches shall be 1.75 inches minimum.
(3) Surface texture per ANSVASME B46.1. Head to shank fillet, thread flanks and thread root 32; bearing surface of head 63; other surfaces 125.
(4) Dimensions in inches to be met after plating. Unless otherwise specified, tolerances: ±.010 angles ±1°
(5) Gaging of the CRUCIFORM recess shall be in accordance with MS9006, gage penetration noted above. Gage penetration from surface "P" on optional head per note (8).
(6) Orientation of recess slots to hex is optional.
(7) Screws shall be free from burrs and slivers.
(8) Circular indentation defined by dimensions "P" and "K" optional for sizes 04, 06, 08 and 3 only. Indentation not allowable for sizes 4, 5 and 6.
(9) "N min" to be measured at "B min".
(10) Head chamfer angle optional, not to exceed 30° maximum.
(11) Drill "M" dia. (three holes) within .010 of center of Hex flat when specified by part number.

PROCUREMENT SPECIFICATION: MIL-B-87114, except as noted. Cold working of head to shank fillet radius, thread rolling after heat treat, wrench torque testing not required. Requirements for sizes .164 and smaller shall be in accordance with NAS4002. Packaging per NAS4002.

CUSTODIAN NATIONAL AEROSPACE STANDARDS COMMITTEE



PROCUREMENT SPECIFICATION NOTED

(2) TITLE
SCREW, HEX HEAD, CRUCIFORM RECESS, FULL THREAD, ALLOY STEEL, 160,000 PSI TENSILE

CLASSIFICATION
STANDARD PART
NAS1801

USE OF OR RELIANCE UPON THIS DOCUMENT OR ANY NATIONAL AEROSPACE STANDARD IS ENTIRELY VOLUNTARY. AIA DOES NOT QUALIFY SUPPLIERS OR CERTIFY CONFORMANCE OF ITEMS PROCURED UNDER NATIONAL AEROSPACE STANDARDS. AIA MAKES NO REPRESENTATION OR CLAIM RESPECTING (1) THE SUITABILITY OF ITEMS FOR ANY PARTICULAR APPLICATION, OR (2) THE EXISTENCE OF OR APPLICABILITY THERETO OF PATENT OR TRADEMARK RIGHTS.

AEROSPACE INDUSTRIES ASSOCIATION OF AMERICA, INC.
1250 EYE STREET, N.W.
WASHINGTON, D.C. 20005

THIS DRAWING SUPERSEDES ALL ANTECEDENT STANDARD DRAWINGS FOR THE SAME PRODUCT AND SHALL BECOME EFFECTIVE NO LATER THAN SIX MONTHS FROM THE LAST DATE OF APPROVAL SHOWN HEREON.

APPROVAL DATE MARCH 1977 REVISION (1) 4 APRIL 1984 (2) 15 APRIL 1994