



Aerospace Industries Association

**NATIONAL AEROSPACE STANDARD**  
 ©COPYRIGHT 1999 AEROSPACE INDUSTRIES ASSOCIATION OF AMERICA INC. ALL RIGHTS RESERVED

FED SUP CLASS  
5325

AEROSPACE INDUSTRIES ASSOCIATION OF AMERICA, INC.  
WASHINGTON, D.C. 20005

THIS DRAWING SUPERSEDES ALL ANTECEDENT STANDARD DRAWINGS FOR THE SAME PRODUCT AND SHALL BECOME EFFECTIVE NO LATER THAN SIX MONTHS FROM THE LAST DATE OF APPROVAL SHOWN HEREON.

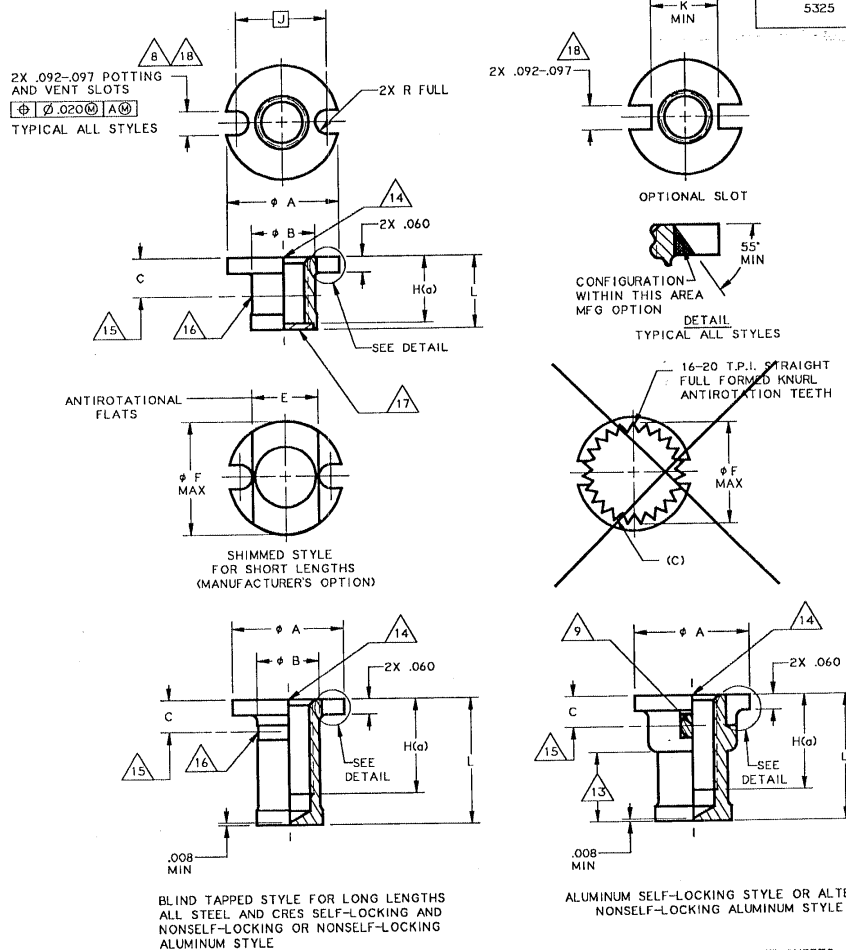

(B) COMPLETELY REVISED

LIST OF CURRENT SHEETS

NO.	REV.
1	8
2	6
3	1

CUSTODIAN: NATIONAL AEROSPACE STANDARDS COMMITTEE

PROCUREMENT SPECIFICATION  
NONE

TITLE  
INSERT, MOLDED IN, BLIND THREADED, SELF-LOCKING, NONSELF-LOCKING, LIGHTWEIGHT, SANDWICH PANEL

THIRD ANGLE PROJECTION  
 CLASSIFICATION PART STANDARD  
**NAS1836**  
 SHEET 1 OF 3

USE OF OR RELIANCE UPON THIS DOCUMENT OR ANY NATIONAL AEROSPACE STANDARD IS ENTIRELY VOLUNTARY. AIA DOES NOT QUALIFY SUPPLIERS OR CERTIFY CONFORMANCE OF ITEMS PROCURED UNDER NATIONAL AEROSPACE STANDARDS. AIA MAKES NO REPRESENTATION OR CLAIM RESPECTING (1) THE SUITABILITY OF ITEMS FOR ANY PARTICULAR APPLICATION, OR (2) THE EXISTENCE OF OR APPLICABILITY THERETO OF PATENT OR TRADEMARK RIGHTS.

APPROVAL DATE June 1970 REVISION (B) 18 June 1999



NATIONAL AEROSPACE STANDARD

©COPYRIGHT 1999 AEROSPACE INDUSTRIES ASSOCIATION OF AMERICA INC. ALL RIGHTS RESERVED

TABLE I

FIRST DASH NO	THREAD CLASS 3B MINOR DIA [-A-]	φ A + .000 - .010	φ B	C	E	φ F MAX	H(a)	J BASIC	K MIN	L(b) MIN	INSTALLATION HOLE SIZE
-06	.1380-32UNJC	.451	.250	.12	.260	.45	.187	.358	.251	.217	.452-.457
-08	.1640-32UNJC	.451	.250	.12	.260	.45	.187	.358	.251	.217	.452-.457
-3	.1900-32UNJF	.451	.250	.12	.260	.45	.187	.358	.251	.217	.452-.457
-4	.2500-28UNJF	.498	.300	.14	.312	.49	.250	.405	.298	.279	.499-.504

- (a) MINIMUM THREAD "H" IN SHORT LENGTHS. MINIMUM THREAD "H" WHERE LENGTH PERMITS SHALL BE 2X DIAMETER OF THREAD.
- (b) MINIMUM LENGTH WHICH MAY BE SPECIFIED.
- ~~(c) BOTTOM FLANGE ANTIROTATION CONFIGURATION OPTIONAL. SEE NOTE 12.~~

MATERIAL: CARBON STEEL PER ASTM A108, ASTM A576, OR MATERIAL COMPOSITION PER FED-STD-66, ULTIMATE TENSILE STRENGTH 85 KSI MINIMUM.  
 AL ALLOY, GRADE 2024 (UNS A92024), TEMPER T4 OR T351 PER QQ-A-225/6.  
 CORROSION RESISTANT STEEL, TYPE 303 (UNS S30300) PER ASTM A582.  
 NONMETALLIC LOCKING ELEMENT - POLYAMIDE PER FED SPEC L-P-410.

FINISH: CARBON STEEL - CADMIUM PLATE PER QQ-P-416, TYPE II, CLASS 2.  
 AL ALLOY - ANODIZE PER MIL-A-8625, TYPE I, CLASS OPTIONAL.  
 CRES - PASSIVATE PER QQ-P-35, TYPE II; SILVER PLATE PER AMS2410 OR AMS2411, OR CADMIUM PLATE PER QQ-P-416, TYPE II, CLASS 2.

SOLID FILM LUBRICANT PER AS5272 TYPE I, APPLIED TO THREADS ONLY.  
 CODING: NO LETTER AFTER BASIC NUMBER INDICATES CARBON STEEL, CADMIUM PLATED.  
 SUFFIX A TO BASIC NUMBER INDICATES AL ALLOY, ANODIZED.  
 SUFFIX C TO BASIC NUMBER INDICATES CRES, PASSIVATED.  
 FIRST DASH NUMBER INDICATES NOMINAL THREAD SIZE, SEE TABLE I  
 SUFFIX N TO FIRST DASH NUMBER INDICATES NONSELF-LOCKING.  
 SECOND DASH NUMBER INDICATES LENGTH IN .031 INCREMENTS; ALWAYS USE TWO DIGIT DASH NUMBER. (SEE NOTE 6)  
 NO LETTER AFTER SECOND DASH NUMBER FOR CRES INDICATES PASSIVATE ONLY.  
 SEE NOTE 5.  
 SUFFIX M TO SECOND DASH NUMBER INDICATES SOLID FILM LUBRICANT.  
 SEE NOTE 5.  
 SUFFIX P TO SECOND DASH NUMBER INDICATES CADMIUM PLATE ON CRES INSERT.  
 SEE NOTE 5.  
 SUFFIX S TO SECOND DASH NUMBER INDICATES SILVER PLATE ON CRES INSERT.  
 SEE NOTE 5.

AEROSPACE INDUSTRIES ASSOCIATION OF AMERICA, INC.  
 1550 EYE STREET, N.W.  
 WASHINGTON, D.C. 20005

THIS DRAWING SUPERSEDES ALL ANTECEDENT STANDARD DRAWINGS OF THE SAME TITLE AND DATE OF APPROVAL SHOWN HEREON FROM SIX MONTHS FROM THE LAST DATE OF APPROVAL.

APPROVAL DATE June 1970 REVISION (6) 18 June 1999

NAS1836

SHEET 2

(6) COMPLETELY REVISED

USE OF OR RELIANCE UPON THIS DOCUMENT OR ANY NATIONAL AEROSPACE STANDARD IS ENTIRELY VOLUNTARY. AIA DOES NOT QUALIFY SUPPLIERS OR CERTIFY CONFORMANCE OF ITEMS PROCURED UNDER NATIONAL AEROSPACE STANDARDS. AIA MAKES NO REPRESENTATION OR CLAIM RESPECTING (1) THE SUITABILITY OF ITEMS FOR ANY PARTICULAR APPLICATION, OR (2) THE EXISTENCE OF OR APPLICABILITY THERETO OF PATENT OR TRADEMARK RIGHTS.



Aerospace  
Industries  
Association

NATIONAL AEROSPACE STANDARD

©COPYRIGHT 1999 AEROSPACE INDUSTRIES ASSOCIATION OF AMERICA INC. ALL RIGHTS RESERVED

AEROSPACE INDUSTRIES ASSOCIATION OF AMERICA, INC.  
1250 EYE STREET, N.W.  
WASHINGTON, DC 20005

EXAMPLE OF PART NUMBER

- NAS1836-3-08M .1900-32UNJF-3B THREAD, CARBON STEEL, CADMIUM PLATED  
WITH SOLID FILM LUBRICANT, .248 LONG, SELF-LOCKING.
- NAS1836A3N09 .1900-32UNJF-3B THREAD, AL ALLOY, ANODIZED,  
.279 LONG, NONSELF-LOCKING.
- NAS1836C08-10S .1640-32UNJC-3B THREAD, CRES, SILVER PLATED  
.310 LONG, SELF-LOCKING.
- NAS1836C08-10P .1640-32UNJC-3B THREAD, CRES, CADMIUM PLATED  
.310 LONG, SELF-LOCKING.
- NAS1836C4N12 .2500-28UNJF-3B THREAD, CRES, PASSIVATED,  
.372 LONG, NONSELF-LOCKING.

NOTES:

1. THREADS PER MIL-S-8879.
2. LOCKING TORQUE PER MIL-DTL-25027 EXCEPT SELF-LOCKING, CORROSION RESISTANT STEEL INSERT WITHOUT PLATING OR LUBRICANT WILL BE TESTED USING A SILVER PLATED BOLT OR SCREW.
3. TOLERANCES UNLESS OTHERWISE SPECIFIED:  
.XXX - ±.010  
.XX - ±.02
4. AN ADHESIVE-BACKED INSTALLATION TAB NAS1837 (ALUMINUM OR PLASTIC) SHALL BE FURNISHED WITH EACH INSERT.  
NOTE WHEN TAB MATERIAL PREFERENCE IS DESIRED, PROCURING ACTIVITY SHALL SPECIFY.
5. PLATING OR SOLID FILM LUBRICANT IS RECOMMENDED ON SELF-LOCKING CRES INSERTS.
6. SELECT A LENGTH WHICH WILL ALLOW A MINIMUM .040 CLEARANCE BETWEEN BOTTOM OF INSERT AND INSIDE SURFACE OF BOTTOM SKIN.
7. MAXIMUM BOLT ENGAGEMENT SHOULD NOT EXCEED "L" MINUS .060.
8. BURRS CAUSED BY MACHINING POTTING HOLES OR SLOTS PERMISSIBLE UNDER FLANGE.
9. NONMETALLIC THREAD LOCK WHEN APPLICABLE.  
LOCATE PELLETS NO CLOSER THAN 10' FROM EDGE OF EITHER POTTING HOLE OR SLOT.
10. DIMENSIONING AND TOLERANCING PER ANSI Y14.5M-1982.
11. DIMENSIONS IN INCHES UNLESS OTHERWISE NOTED.
- ~~12. PARTS MANUFACTURED WITH OPTIONAL FLANGE CONFIGURATION, KNURLED ANTIROTATION TEETH, MAY BE FURNISHED FROM SUPPLIERS STOCK UNTIL JULY 31, 1995.~~
13. EXTERNAL CONFIGURATION OPTIONAL IN THIS AREA FOR SHORT LENGTHS THROUGH .375.
14. MINIMUM "GO" THREAD GAGE PENETRATION SHALL BE ONE HALF REVOLUTION BEFORE LUBRICATION. MINIMUM BOLT THREAD PENETRATION SHALL BE THREE QUARTER REVOLUTION AFTER LUBRICATION.
15. CENTERLINE OF THREAD LOCK WHEN APPLICABLE.
16. SHANK DEFORMED IN THIS AREA TO PROVIDE THREAD LOCK WHEN APPLICABLE.
17. SHIM TO PROVIDE MAXIMUM THREAD ON SHORT LENGTH INSERT IF NECESSARY.
18. POTTING AND VENT HOLES OR SLOTS (MANUFACTURER'S OPTION).
19. ALL DIAMETERS SHALL BE WITHIN .010 CIRCULAR RUNOUT TO DATUM A.
20. DIMENSIONAL LIMITS APPLY AFTER PLATING, AND PRIOR TO SOLID FILM LUBE.

7 COMPLETELY REVISED

NAS1836 SHEET 3

THIS DRAWING SUPERSEDES ALL PREVIOUS STANDARD DRAWINGS FOR THIS PART NUMBER. THE DATE OF APPROVAL SHOWN HEREIN IS SIX MONTHS FROM THE LAST DATE OF APPROVAL.

APPROVAL DATE June 1960 REVISION 1 18 June 1999

USE OF OR RELIANCE UPON THIS DOCUMENT OR ANY NATIONAL AEROSPACE STANDARD IS ENTIRELY VOLUNTARY. AIA DOES NOT QUALIFY SUPPLIERS OR CERTIFY CONFORMANCE OF ITEMS PROCURED UNDER NATIONAL AEROSPACE STANDARDS. AIA MAKES NO REPRESENTATION OR CLAIM RESPECTING (1) THE SUITABILITY OF ITEMS FOR ANY PARTICULAR APPLICATION, OR (2) THE EXISTENCE OF OR APPLICABILITY THERETO OF PATENT OR TRADEMARK RIGHTS.