

Primax™

Synonymous with function and performance, enter the Primax, the new era of high intensity illumination in LED. With its high flux output and high luminous intensity, Primax transcends today LED lightings technology and how we perceive it. The small package outline (3.5 x 3.5 x 1.2 mm) and high intensity make it an ideal choice for backlighting, signage, exterior automotive lighting and decorative lighting.

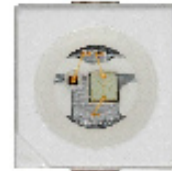

Features:

- > Super high brightness surface mount LED
- > 120° viewing angle.
- > Compact package outline (LxW) of 3.5 x 3.5 mm.
- > Ultra low height profile - 1.2mm.
- > Low thermal resistance.
- > Compatible to IR reflow soldering.
- > Environmental friendly; RoHS compliance.

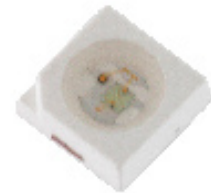

Applications:

- > Lighting: garden light, architecture lighting, general lighting. etc
- > Backlighting (TFT LCD display), flash light, architectural lighting.



Optical Characteristics at Tj=25°C

Part Ordering Number	Color	Viewing Angle°	Luminous Flux @ IF = 150mA (lm)			Intensity @ IF = 150mA (cd)
			Min.	Typ.	Max.	Typ.
NAB-FSG-HJ-1	Blue	120	4.9	6.0	8.2	2.2
NAT-FSG-NP-1	True Green	120	18.1	22.0	30.6	8.1

NOTE

1. Luminous flux is measured with an accuracy of ± 11%.
2. Wavelength binning is carried for all units as per the wavelength-binning table. Only one wavelength group is allowed for each reel.

Electrical Characteristics at Tj=25°C

Part Number	Vf @ If = 150 mA		
	Min. (V)	Typ. (V)	Max. (V)
NAB-FSG	3.0	3.4	3.9
NAT-FSG	3.0	3.4	3.9

Forward Voltages are tested using a current pulse of 1 ms and has an accuracy of ± 0.1 V.

Absolute Maximum Ratings

	Maximum Value	Unit
DC forward current	180	mA
Peak pulse current (tp<=10ms, Duty cycle=0.10)	350	mA
Reverse voltage	Not designed for reverse bias	V
ESD threshold (HBM)	2000	V
LED junction temperature	125	°C
Operating temperature	-40 ... +100	°C
Storage temperature	-40 ... +100	°C

Wavelength Grouping at Tj=25°C

Color	Group	Wavelength distribution (nm)
NAT; True Green	Full	520 - 535
	A	520 - 525
	B	525 - 530
	C	530 - 535
NAB; Blue	Full	460 - 470
	A	460 - 465
	B	465 - 470

Dominant wavelength is measured with an accuracy of ± 1 nm at a drive current of 150mA

Luminous Flux at Tj=25°C

Brightness Group	Luminous Flux (lm)
H2	4.90...5.50
H3	5.50...6.30
J2	6.30...7.15
J3	7.15...8.20
N2	18.1...20.6
N3	20.6...23.5
P2	23.5...26.8
P3	26.8...30.6

Luminous flux is measured with an accuracy of ± 11%.

Relative Intensity Vs Forward Current

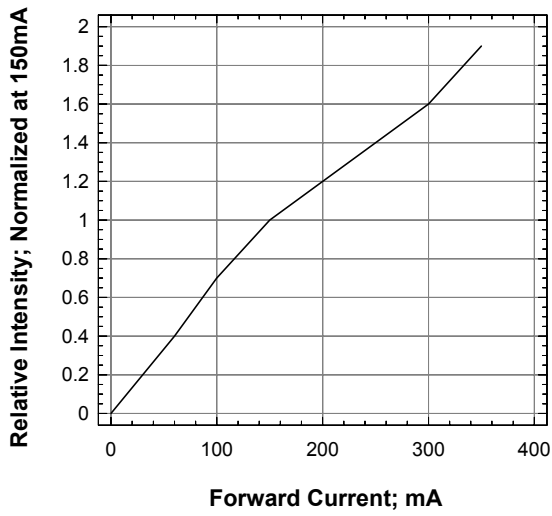

Forward Current vs Forward Voltage

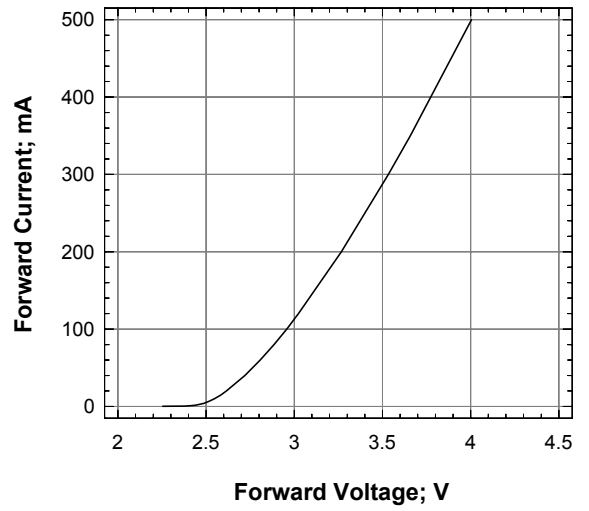

Relative Intensity Vs Wavelength

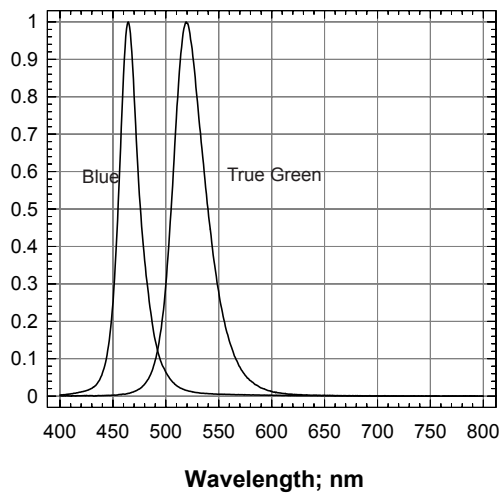

Forward Current Vs Ambient Temperature

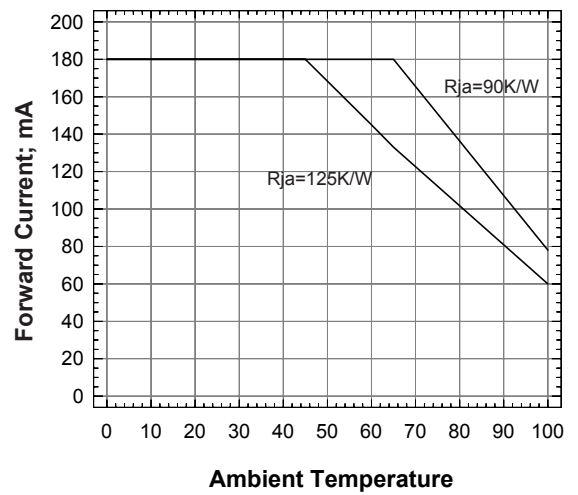

Radiation Pattern

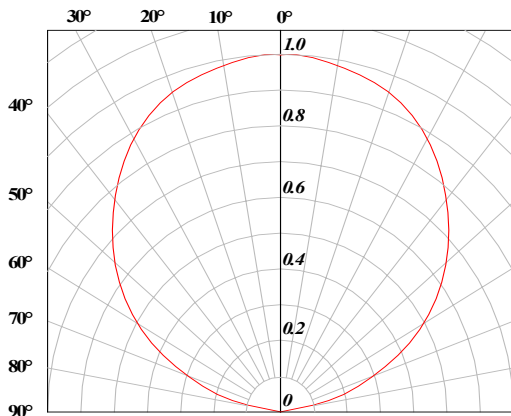

Primax™ • 150 InGaN : NAX-FSG Package Outlines

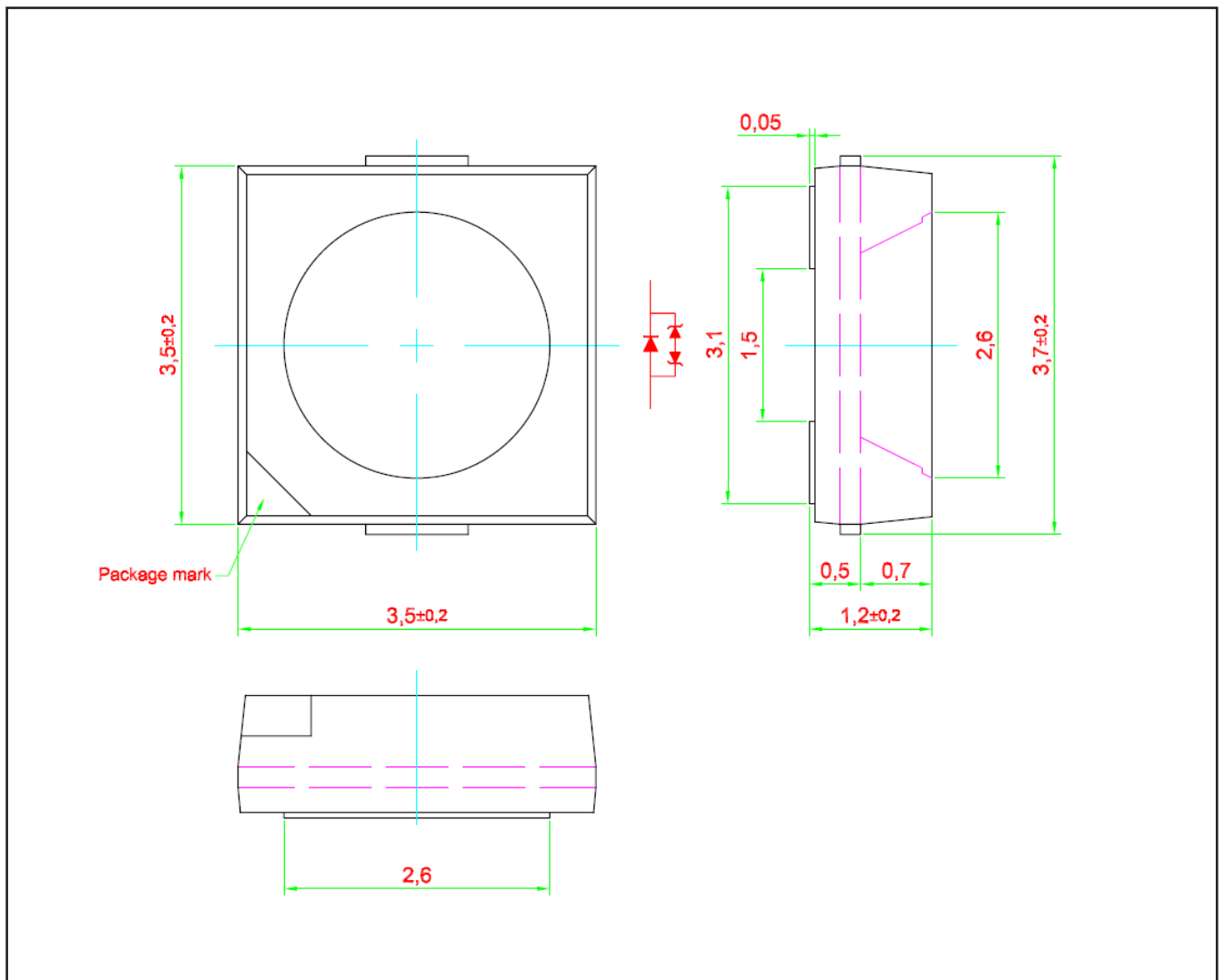

Material

Material	
Lead-frame	Cu Alloy With Ag Plating
Package	High Temperature Resistant Plastic, PPA
Encapsulant	Silicone Resin
Soldering Leads	Sn-Sn Plating

Note: This product is Pb free

Recommended Solder Pad

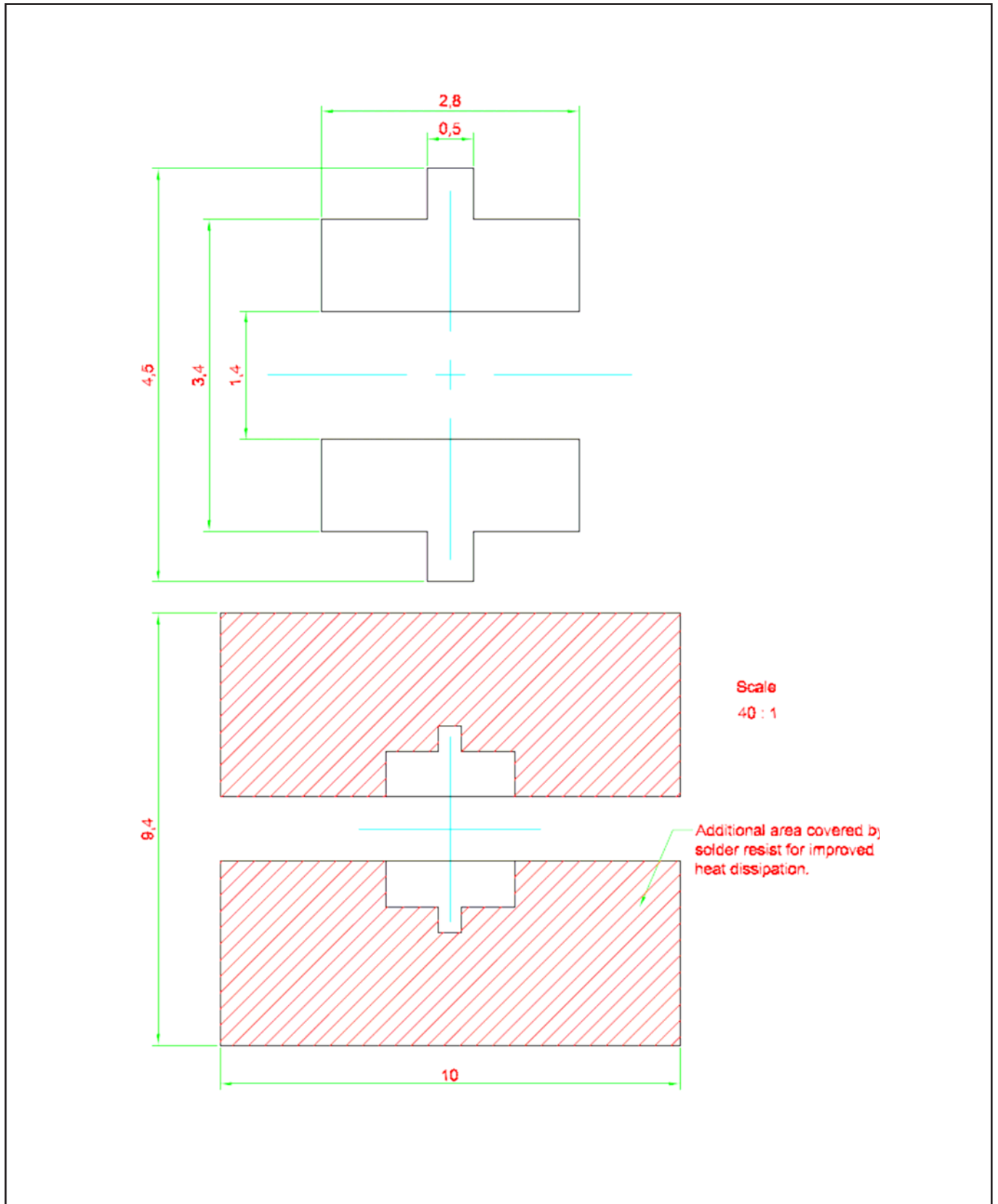

Taping and orientation

- Reels come in quantity of 1000 units.
- Reel diameter is 180 mm.

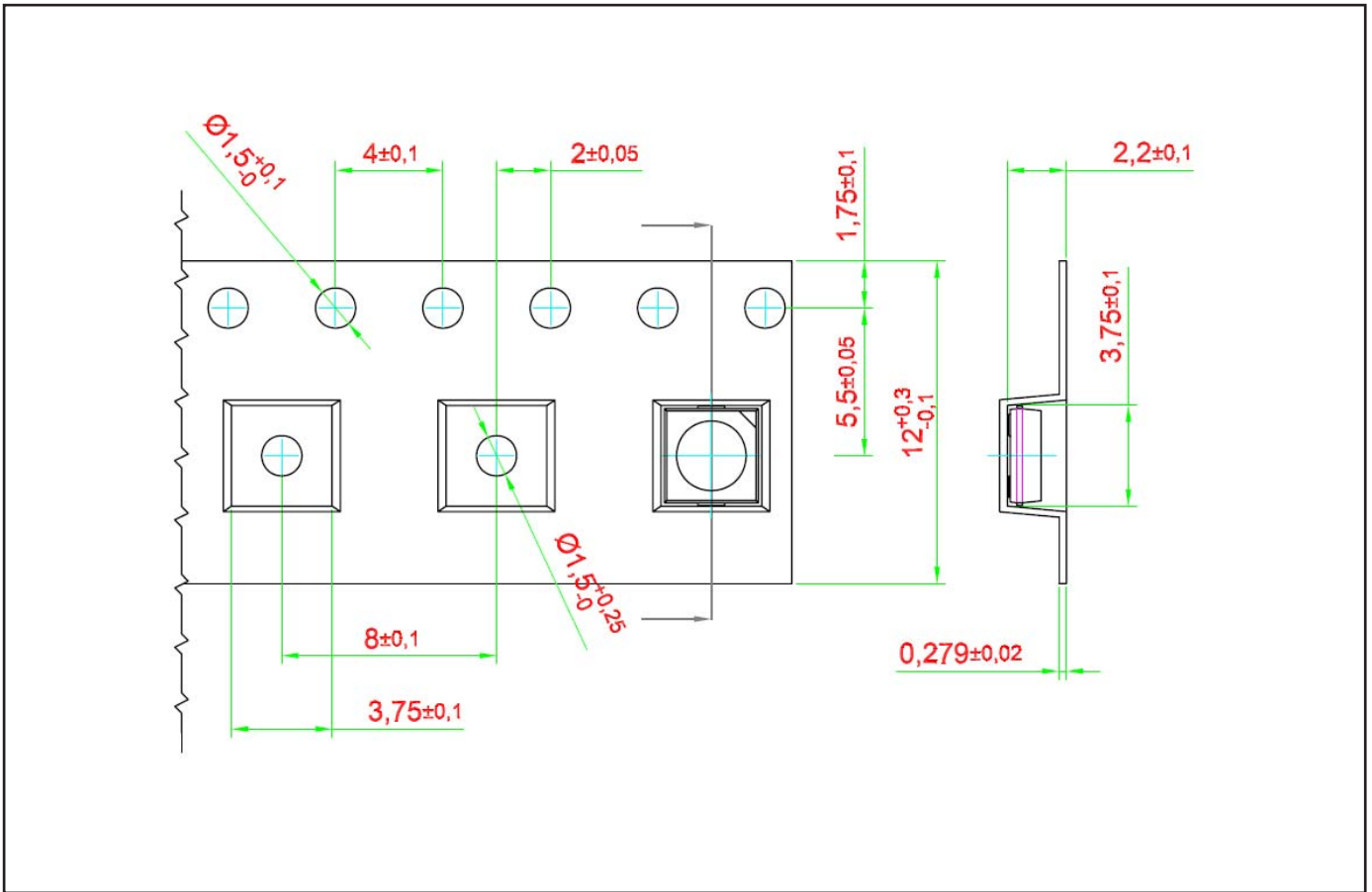

Packaging Specification

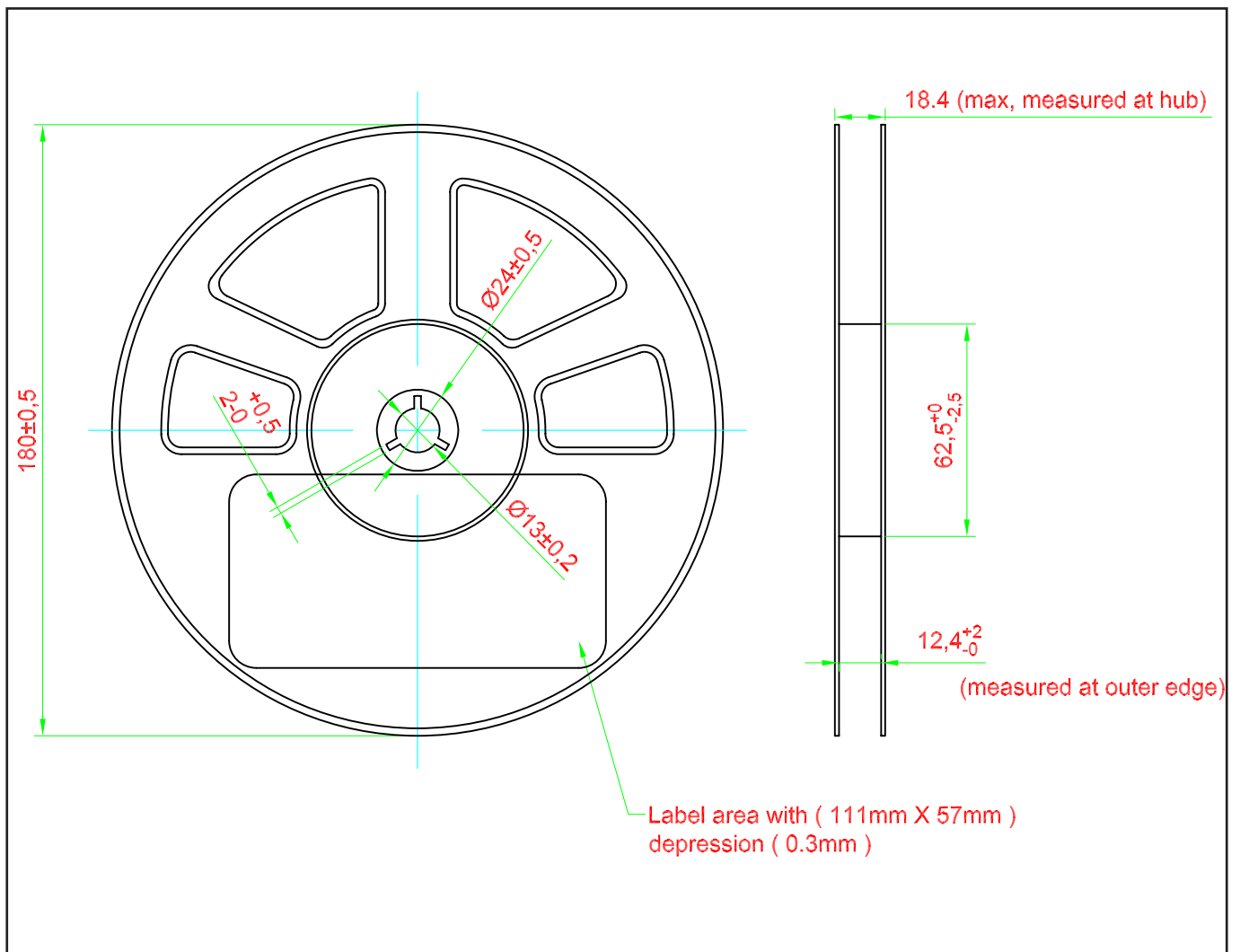

Packaging Specification

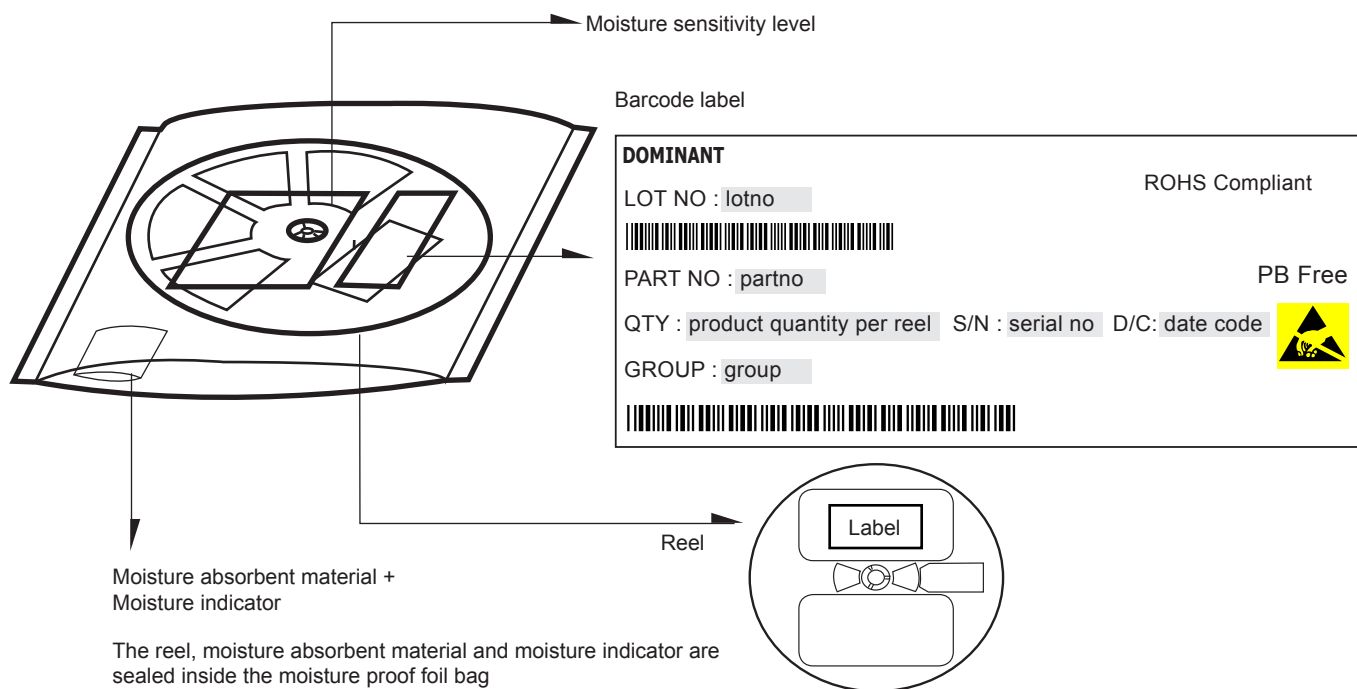

	Average 1pc Primax	1 completed bag (1000pcs)
Weight (gram)	0.041	160 ± 10

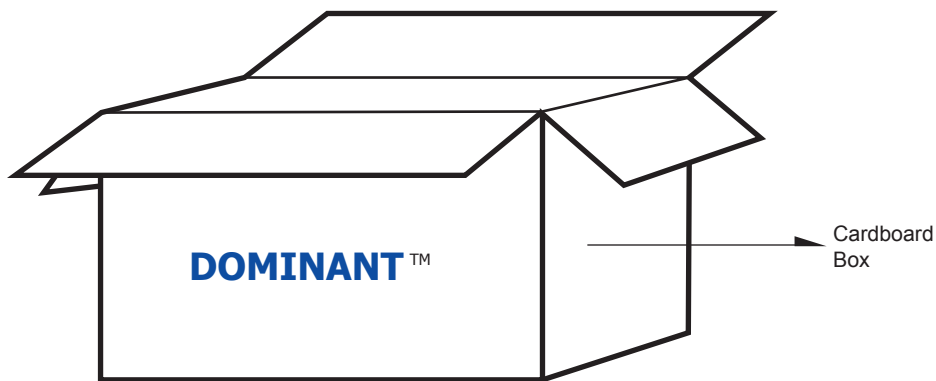

For Primax™

Cardboard Box Size	Dimensions (mm)	Empty Box Weight (kg)	Reel / Box	Quantity / Box (pcs)
Small	300 x 250 x 250	0.58	15 reels MAX	15,000 MAX
Large	416 x 516 x 476	1.74	96 reels MAX	192,000 MAX

Recommended Sn-Pb IR-Reflow Soldering Profile

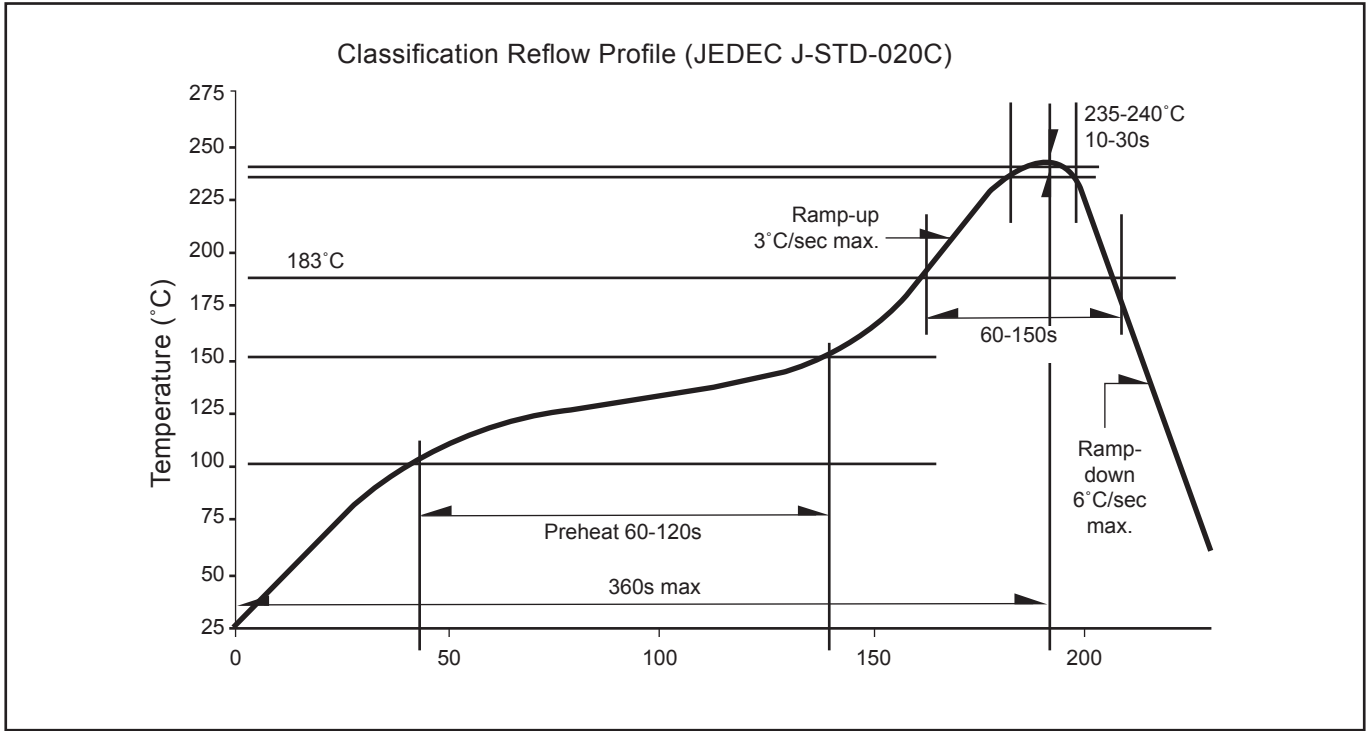

Recommended Pb-free Soldering Profile

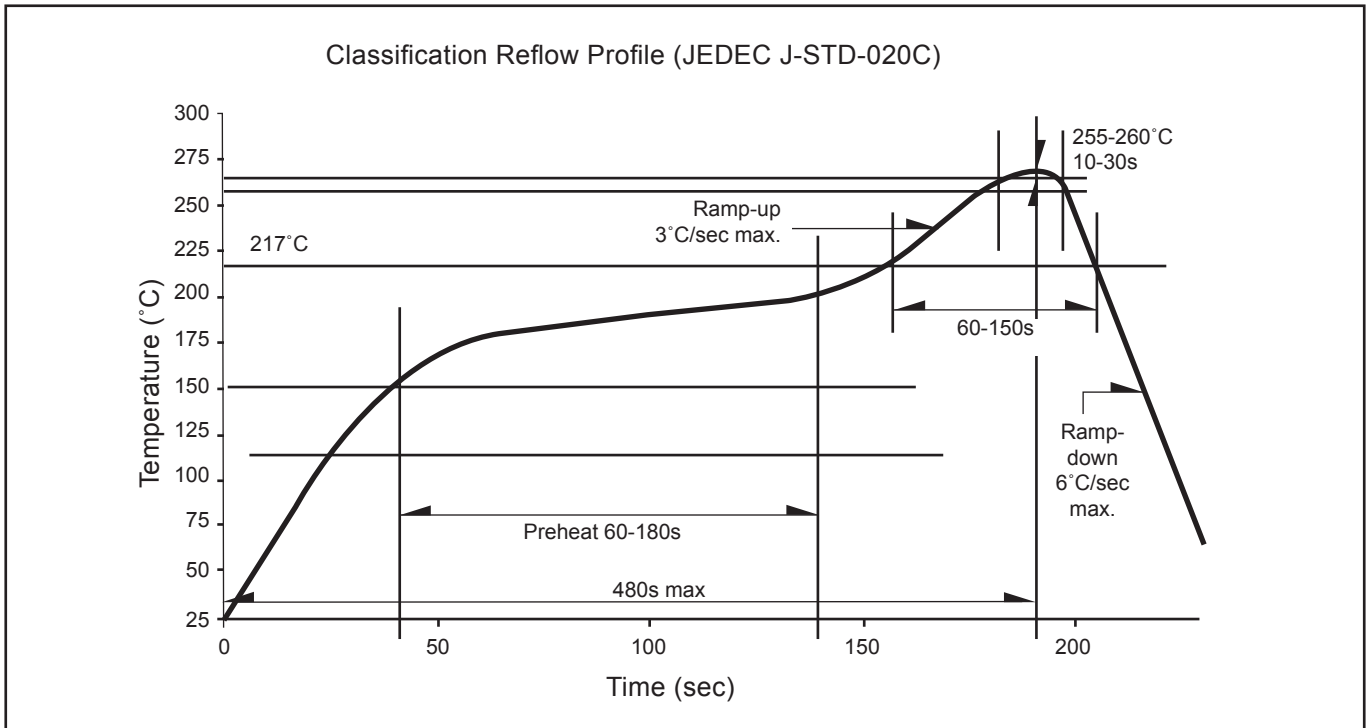

Revision History

Page	Subjects	Date of Modification
-	Initial Release	24 Jun 2011

NOTE

All the information contained in this document is considered to be reliable at the time of publishing. However, DOMINANT Opto Technologies does not assume any liability arising out of the application or use of any product described herein.

DOMINANT Opto Technologies reserves the right to make changes to any products in order to improve reliability, function or design.

DOMINANT Opto Technologies products are not authorized for use as critical components in life support devices or systems without the express written approval from the Managing Director of DOMINANT Opto Technologies.

About Us

DOMINANT Opto Technologies is a dynamic Malaysian Corporation that is among the world's leading SMT LED Manufacturers. An excellence – driven organization, it offers a comprehensive product range for diverse industries and applications. Featuring an internationally certified quality assurance acclaim, DOMINANT's extra bright LEDs are perfectly suited for various lighting applications in the automotive, consumer and communications as well as industrial sectors. With extensive industry experience and relentless pursuit of innovation, DOMINANT's state-of-art manufacturing, research and testing capabilities have become a trusted and reliable brand across the globe. More information about DOMINANT Opto Technologies can be found on the Internet at <http://www.dominant-semi.com>.

Please contact us for more information:

Head Quarter

DOMINANT Opto Technologies Sdn. Bhd.
Lot 6, Batu Berendam, FTZ Phase III, 75350 Melaka, Malaysia
Tel: (606) 283 3566 Fax: (606) 283 0566
E-mail: sales@dominant-semi.com

DOMINANT Opto Technologies Sdn. Bhd. Shanghai Representative Office

Rm 1007, DaZhong Building, No. 1515 Zhong Shan (W) Rd, Shanghai, China 200235
Tel: +86 21 6428 6428 Fax: +86 21 6428 6880
E-mail: sales_china@dominant-semi.com

DOMINANT Korea Sales Office

DOMINANT Semiconductors Korea Inc.
RM 211 SUNTEAK CITY APT. 513-15 Sangdaewon-dong, Jungwon-gu, Seongnam-si, Gyeonggi-do, 462-725, Korea
Tel: +82-31-701-5203 Fax: +82-31-701-5204
E-mail: sales_korea@dominant-semi.com

DOMINANT U.S.A Sales Office

25 Rockaway Road, 08833 Lebanon, New Jersey, USA
Tel: (908) 439-9930 Cell: (908) 343-5810 Fax: (908) 439-9929
E-mail: don.wendel@dominant-semi.com

DOMINANT Europe Sales Office

DOMINANT Semiconductors Europe GmbH
Raiffeisenstr. 38, 74906 Bad Rappenau Germany
Tel: +49 (0) 7264-89010-10 / +49 (0) 7264-89010-11 Cell: +49 173-6907370 / +49 173-6907751
Fax: +49 (0) 7264-89010-29
E-mail: gerd.wachno@dominant-semi.eu; hartmut.wettengl@dominant-semi.eu

DOMINANT India Sales Office

C-11, Vasanth Business Centre #86, TTK Road, Alwarpet Chennai - 600 018, INDIA
Tel: 91-44-42030616 / 516 Cell: 91-9444920537 Fax: 91-9444920616
E-mail: pravat.behera@dominant-semi.com

