

Surface Mount Aluminum Electrolytic Capacitors NAZU Series

FEATURES

- CYLINDRICAL V-CHIP CONSTRUCTION FOR SURFACE MOUNTING
 - LOW IMPEDANCE AT 100KHz
 - EXTENDED LOAD LIFE (3,000 @ +105°C)
 - DESIGNED FOR 260°C REFLOW SOLDERING
 - **MEETS THE REQUIREMENTS OF AEC-Q200***
- *Contact NIC for supporting test data

SAC Alloy Compatible
230°C ~ 260°C

RoHS Compliant
includes all homogeneous materials



*See Part Number System for Details

CHARACTERISTICS

Rated Voltage Rating	6.3 ~ 50Vdc						
Rated Capacitance Range	10 ~ 330μF						
Operating Temp. Range	-40 ~ +105°C						
Capacitance Tolerance	±20% (M)						
Max. Leakage Current After 2 Minutes @ 20°C	0.01CV or 3μA whichever is greater						
Tan δ @ 120Hz/20°C	W.V. (Vdc)	6.3	10	16	25	35	50
	S.V. (Vdc)	8.0	13	20	32	44	63
	Tan δ	0.28	0.24	0.22	0.16	0.13	0.12
Low Temperature Stability Impedance Ratio @ 120Hz	W.V. (Vdc)	6.3	10	16	25	35	50
	Z-25°C/Z+20°C	432222					
Load Life Test @ 105°C at Rated Working Voltage 3,000 hrs	Z-40°C/Z+20°C	10	75333				
	Capacitance Change	Within ±30% of initial measured value					
Leakage Current	Tan δ	Less than ±300% of the specified maximum value					
	Leakage Current	Less than the specified maximum value					

LOW ESR COMPONENT
LIQUID ELECTROLYTE
For Performance Data see www.LowESR.com

STANDARD VALUES AND CASE SIZES (mm)

Cap (μF)	Code	Working Voltage (Vdc)					
		6.3	10	16	25	35	50
10	100	----				5x6.3	6.3x6.3
22	220	-	-	5x6.3	5x6.3	6.3x6.3	6.3x6.3
33	330	-	5x6.3	-	6.3x6.3	-	6.3x8
47	470	5x6.3	-	6.3x6.3	6.3x6.3	6.3x8	-
100	101	6.3x6.3	-	6.3x6.3	6.3x8	-	-
150	151	-	6.3x6.3	6.3x8	-	-	-
220	221	6.3x8	-	6.3x8	-	-	-
330	331	6.3x8	-	-	-	-	-

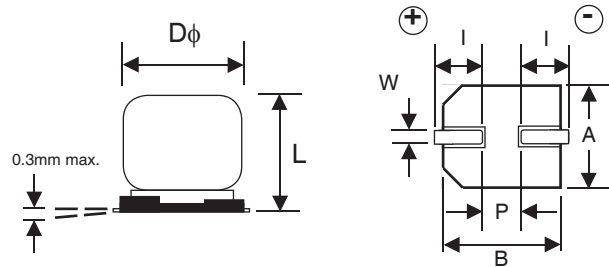

PART NUMBER SYSTEM

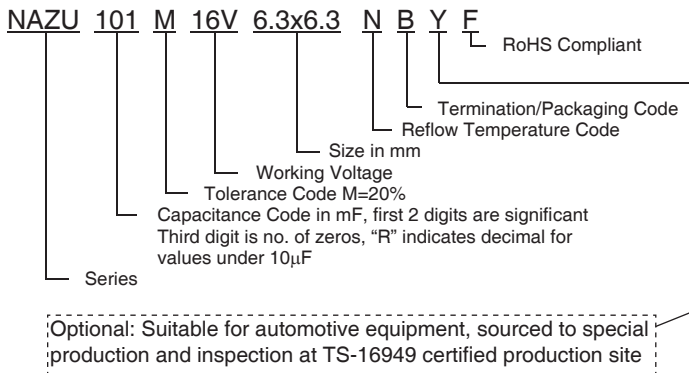

PEAK REFLOW TEMPERATURE CODES

Code	Peak Reflow Temperature
N	260°C

TERMINATION FINISH & PACKAGING OPTIONS CODES

Code	Finish & Reel Size
B	Sn-Bi Finish & 13" Reel
LB	Sn-Bi Finish & 15" Reel
S	100% Sn Finish & 13" Reel
LS	100% Sn Finish & 15" Reel

DIMENSIONS (mm) AND REEL QUANTITIES

Case Size	φD±0.5	L max.	A±0.2	B±0.2	I±0.3	W	P±0.3	Qty/Reel
5x6.3	5.0	6.3	5.3	5.3	2.2	0.5~0.8	1.4	800
6.3x6.3	6.3	6.3	6.6	6.6	2.5	0.5~0.8	2.2	800
6.3x8	6.3	8.0	6.6	6.6	2.5	0.5~0.8	2.2	500

PRECAUTIONS

Please review the notes on correct use, safety and precautions found on pages T10 & T11 of NIC's Electrolytic Capacitor catalog.
Also found at www.niccomp.com/precautions
If in doubt or uncertainty, please review your specific application - process details with NIC's technical support personnel: tpmg@niccomp.com



Surface Mount Aluminum Electrolytic Capacitors NAZU Series

STANDARD VALUES, CASE SIZES AND SPECIFICATIONS

NIC Part Number	Cap. (μF)	W.V. (Vdc)	Dissipation Factor (Tan δ)	Max. Impedance (Ω) +20°C, 100KHz	Max. Ripple Current (mA) +105°C, 100KHz	Load Life Hours @ +105°C
NAZU470M6.3V5X6.3NBF	47	6.3	0.28	1.30	95	3,000
NAZU101M6.3V6.3X6.3NBF	100		0.28	0.70	140	3,000
NAZU221M6.3V6.3X8NBF	220		0.28	0.60	230	3,000
NAZU331M6.3V6.3X8NBF	330		0.28	0.60	230	3,000
NAZU330M10V5X6.3NBF	33	10	0.24	1.30	95	3,000
NAZU151M10V6.3X6.3NBF	150		0.24	0.70	140	3,000
NAZU220M16V5X6.3NBF	22	16	0.22	1.30	95	3,000
NAZU470M16V6.3X6.3NBF	47		0.22	0.70	140	3,000
NAZU101M16V6.3X6.3NBF	100		0.22	0.70	140	3,000
NAZU151M16V6.3X8NBF	150		0.22	0.60	230	3,000
NAZU221M16V6.3X8NBF	220		0.22	0.60	230	3,000
NAZU220M25V5X6.3NBF	22	25	0.16	1.30	95	3,000
NAZU330M25V6.3X6.3NBF	33		0.16	0.70	140	3,000
NAZU470M25V6.3X6.3NBF	47		0.16	0.70	140	3,000
NAZU101M25V6.3X8NBF	100		0.16	0.60	230	3,000
NAZU100M35V5X6.3NBF	10	35	0.13	1.30	95	3,000
NAZU220M35V6.3X6.3NBF	22		0.13	0.70	140	3,000
NAZU470M35V6.3X8NBF	47		0.13	0.60	230	3,000
NAZU100M50V6.3X6.3NBF	10	50	0.12	2.00	70	3,000
NAZU220M50V6.3X6.3NBF	22		0.12	2.00	70	3,000
NAZU330M50V6.3X8NBF	33		0.12	1.35	100	3,000

For Automotive Equipment, see part number system

RIPPLE CURRENT FREQUENCY CORRECTION FACTORS

Frequency	100Hz	1KHz	10KHz	100KHz
10 ~ 33μF	0.60	0.75	0.95	1.00
47 ~ 330μF	0.75	0.85	0.95	1.00

PEAK REFLOW TEMPERATURE AND DURATION

Diameter	Time above 200°C	Time above 230°C	Peak Temperature 5 seconds
5 ~ 6.3mm φ	80 sec. max.	40 sec. max.	260°C

Capacitors can withstand two times reflow at the above conditions. Second reflow shall be at least one hour after natural cool to room temperature.

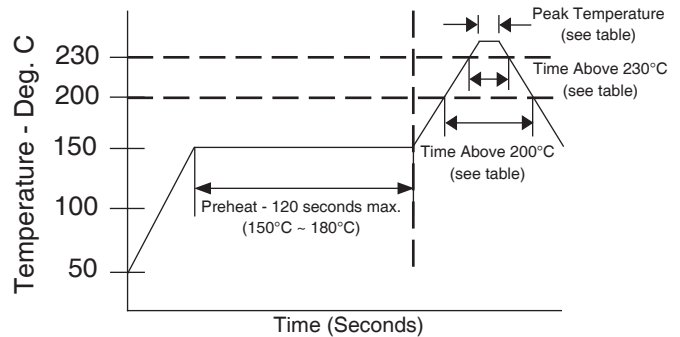

RECOMMENDED LAND PATTERN DIMENSIONS (mm)

Case Size	a	b	c
5x6.3	1.4	3.0	1.8
6x3x6.3 6.3x8	2.1	3.5	1.8

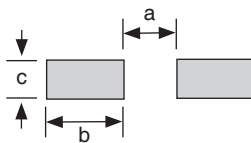

Review & Compare Reflow Soldering Heat Limits
V-chip SMT Aluminum Electrolytic Capacitors
www.niccomp.com/RSL

