

NB3V60113G

1.8 V Programmable OmniClock Generator

with Single Ended (LVCMOS) and Differential (LVDS/HCSL) Outputs

The NB3V60113G, which is a member of the OmniClock family, is a one-time programmable (OTP), low power PLL-based clock generator that supports any output frequency from 8 kHz to 200 MHz. The device accepts fundamental mode parallel resonant crystal or a single ended (LVCMOS) reference clock as input. It generates either three single ended (LVCMOS) outputs, or one single ended output and one differential (LVDS/HCSL) output. The output signals can be modulated using the spread spectrum feature of the PLL (programmable spread spectrum type, deviation and rate) for applications demanding low electromagnetic interference (EMI). Using the PLL bypass mode, it is possible to get a copy of the input clock on any or all of the outputs. The device can be powered down using the Power Down pin (PD#). It is possible to program the internal input crystal load capacitance and the output drive current provided by the device. The device also has automatic gain control (crystal power limiting) circuitry which avoids the device overdriving the external crystal.

Features

- Member of the OmniClock Family of Programmable Clock Generators
- Operating Power Supply: 1.8 V \pm 0.1 V
- I/O Standards
 - ◆ Inputs: LVCMOS, Fundamental Mode Crystal
 - ◆ Outputs: LVCMOS
 - ◆ Outputs: LVDS and HCSL
- 3 Programmable Single Ended (LVCMOS) Outputs from 8 kHz to 200 MHz
- 1 Programmable Differential Clock Output up to 200 MHz
- Input Frequency Range
 - ◆ Crystal: 3 MHz to 50 MHz
 - ◆ Reference Clock: 3 MHz to 200 MHz
- Configurable Spread Spectrum Frequency Modulation Parameters (Type, Deviation, Rate)
- Programmable Internal Crystal Load Capacitors
- Programmable Output Drive Current for Single Ended Outputs



ON Semiconductor®

www.onsemi.com



WDFN8
CASE 511AT

MARKING DIAGRAM

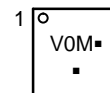

V0 = Specific Device Code
M = Date Code
▪ = Pb-Free Device

(Note: Microdot may be in either location)

ORDERING INFORMATION

See detailed ordering and shipping information on page 19 of this data sheet.

- Power Saving mode through Power Down Pin
- Programmable PLL Bypass Mode
- Programmable Output Inversion
- Programming and Evaluation Kit for Field Programming and Quick Evaluation
- Temperature Range -40°C to 85°C
- Packaged in 8-Pin WDFN
- These are Pb-Free Devices

Typical Applications

- eBooks and Media Players
- Smart Wearables, Portable Medical and Industrial Equipment
- Set Top Boxes, Printers, Digital Cameras and Camcorders

NB3V60113G

BLOCK DIAGRAM

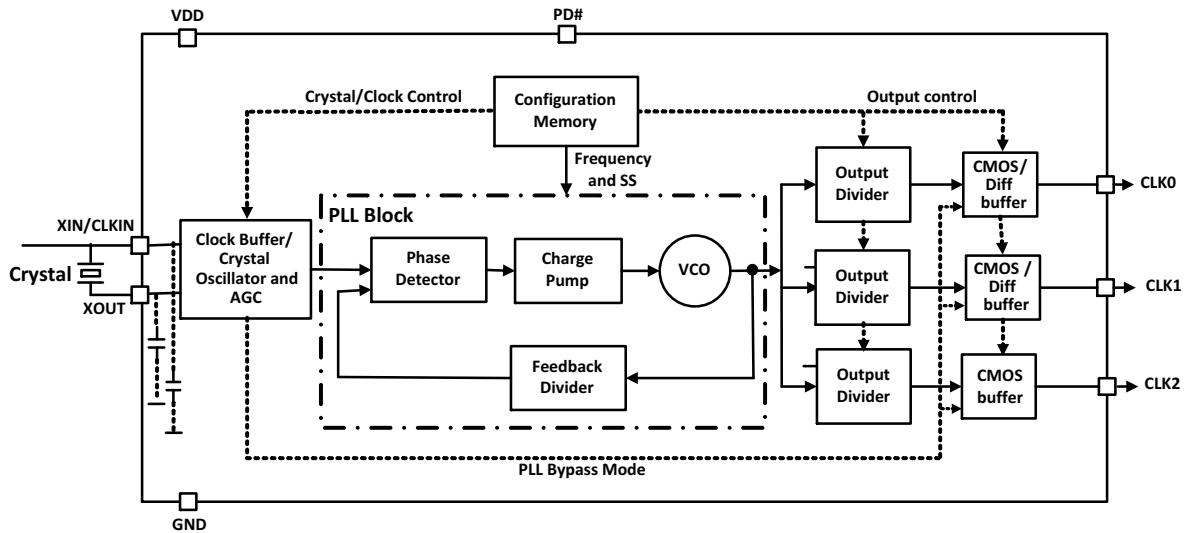

Notes:

1. CLK0 and CLK1 can be configured to be one of LVDS or HCSL output, or two single-ended LVCMOS outputs.
2. Dotted lines are the programmable control signals to internal IC blocks.
3. PD# has internal pull down resistor.

Figure 1. Simplified Block Diagram

PIN FUNCTION DESCRIPTION

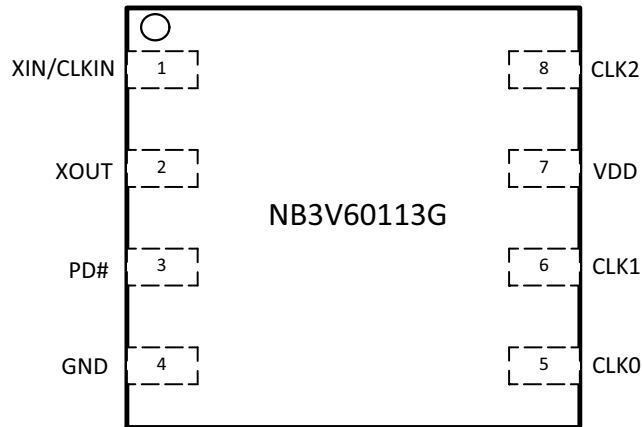

Figure 2. Pin Connections (Top View) – WDFN8

NB3V60113G

Table 1. PIN DESCRIPTION

Pin No.	Pin Name	Pin Type	Description
1	XIN/CLKIN	Input	3 MHz to 50 MHz crystal input connection or an external single-ended reference input clock between 3 MHz and 200 MHz
2	XOUT	Output	Crystal output. Float this pin when external reference clock is connected at XIN
3	PD#	Input	Asynchronous LVCMOS input. Active Low Master Reset to disable the device and set outputs Low. Internal pull-down resistor. This pin needs to be pulled High for normal operation of the chip.
4	GND	Ground	Power supply ground
5	CLK0	SE/DIFF output	Supports 8 kHz to 200 MHz Single-Ended (LVCMOS) signals or Differential (LVDS/HCSL) signals. Using PLL Bypass mode, the output can also be a copy of the input clock. The single ended output will be LOW and differential outputs will be complementary LOW/HIGH until the PLL has locked and the frequency has stabilized.
6	CLK1	SE/DIFF output	Supports 8 kHz to 200 MHz Single-Ended (LVCMOS) signals or Differential (LVDS/HCSL) signals. Using PLL Bypass mode, the output can also be a copy of the input clock. The single ended output will be LOW and differential outputs will be complementary LOW/HIGH until the PLL has locked and the frequency has stabilized.
7	VDD	Power	1.8 V power supply
8	CLK2	SE output	Supports 8 kHz to 200 MHz Single-Ended (LVCMOS) signals. Using PLL Bypass mode, the output can also be a copy of the input clock. The output will be LOW until the PLL has locked and the frequency has stabilized.

Table 2. POWER DOWN FUNCTION TABLE

PD#	Function
0	Device Powered Down
1	Device Powered Up

TYPICAL CRYSTAL PARAMETERS

Crystal: Fundamental Mode Parallel Resonant
 Frequency: 3 MHz to 50 MHz

Table 3. MAX CRYSTAL LOAD CAPACITORS RECOMMENDATION

Crystal Frequency Range	Max Cap Value
3 MHz – 30 MHz	20 pF
30 MHz – 50 MHz	10 pF

Shunt Capacitance (C0): 7 pF (Max)

Equivalent Series Resistance (ESR): 150 Ω (Max)

NB3V60113G

FUNCTIONAL DESCRIPTION

The NB3V60113G is a 1.8 V programmable, single ended / differential clock generator, designed to meet the clock requirements for consumer and portable markets. It has a small package size and it requires low power during operation and while in standby. This device provides the

ability to configure a number of parameters as detailed in the following section. The One-Time Programmable memory allows programming and storing of one configuration in the memory space.

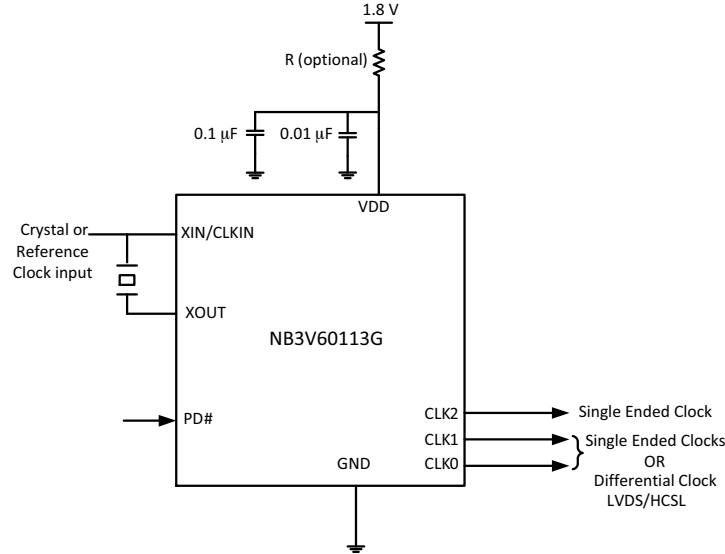

Figure 3. Power Supply Noise Suppression

Power Supply

Device Supply

The NB3V60113G is designed to work with a 1.8 V VDD power supply. For VDD operation of 3.3 V/2.5 V, refer to NB3H60113G datasheet. In order to suppress power supply noise it is recommended to connect decoupling capacitors of 0.1 μF and 0.01 μF close to the VDD pin as shown in Figure 3.

Clock Input

Input Frequency

The clock input block can be programmed to use a fundamental mode crystal from 3 MHz to 50 MHz or a single ended reference clock source from 3 MHz to 200 MHz. When using output frequency modulation for EMI reduction, for optimal performance, it is recommended to use crystals with frequency more than 6.75 MHz as input. Crystals with ESR values of up to 150 Ω are supported. When using a crystal input, it is important to set crystal load capacitor values correctly to achieve good performance.

Programmable Crystal Load Capacitors

The provision of internal programmable crystal load capacitors eliminates the necessity of external load capacitors for standard crystals. The internal load capacitor can be programmed to any value between 4.36 pF and

20.39 pF with a step size of 0.05 pF. Refer to Table 3 for recommended maximum load capacitor values for stable operation. There are three modes of loading the crystal – with internal chip capacitors only, with external capacitors only or with the both internal and external capacitors. Check with the crystal vendor’s load capacitance specification for setting of the internal load capacitors. The minimum value of 4.36 pF internal load capacitor need to be considered while selecting external capacitor value. These will be bypassed when using an external reference clock.

Automatic Gain Control (AGC)

The Automatic Gain Control (AGC) feature adjusts the gain to the input clock based on its signal strength to maintain a good quality input clock signal level. This feature takes care of low clock swings fed from external reference clocks and ensures proper device operation. It also enables maximum compatibility with crystals from different manufacturers, processes, quality and performance. AGC also takes care of the power dissipation in the crystal; avoids over driving the crystal and thus extending the crystal life. In order to calculate the AGC gain accurately and avoid increasing the jitter on the output clocks, the user needs to provide crystal load capacitance as well as other crystal parameters like ESR and shunt capacitance (C0).

NB3V60113G

Programmable Clock Outputs

Output Type and Frequency

The NB3V60113G provides three independent single ended LVC MOS outputs, or one single ended LVC MOS output and one LVDS/HCSL differential output. The device supports any single ended output or differential output frequency from 8 kHz up to 200 MHz with or without

frequency modulation. It should be noted that certain combinations of output frequencies and spread spectrum configurations may not be recommended for optimal and stable operation.

For differential clocking, CLK0 and CLK1 can be configured as LVDS or HCSL. Refer to the Application Schematic in Figure 4.

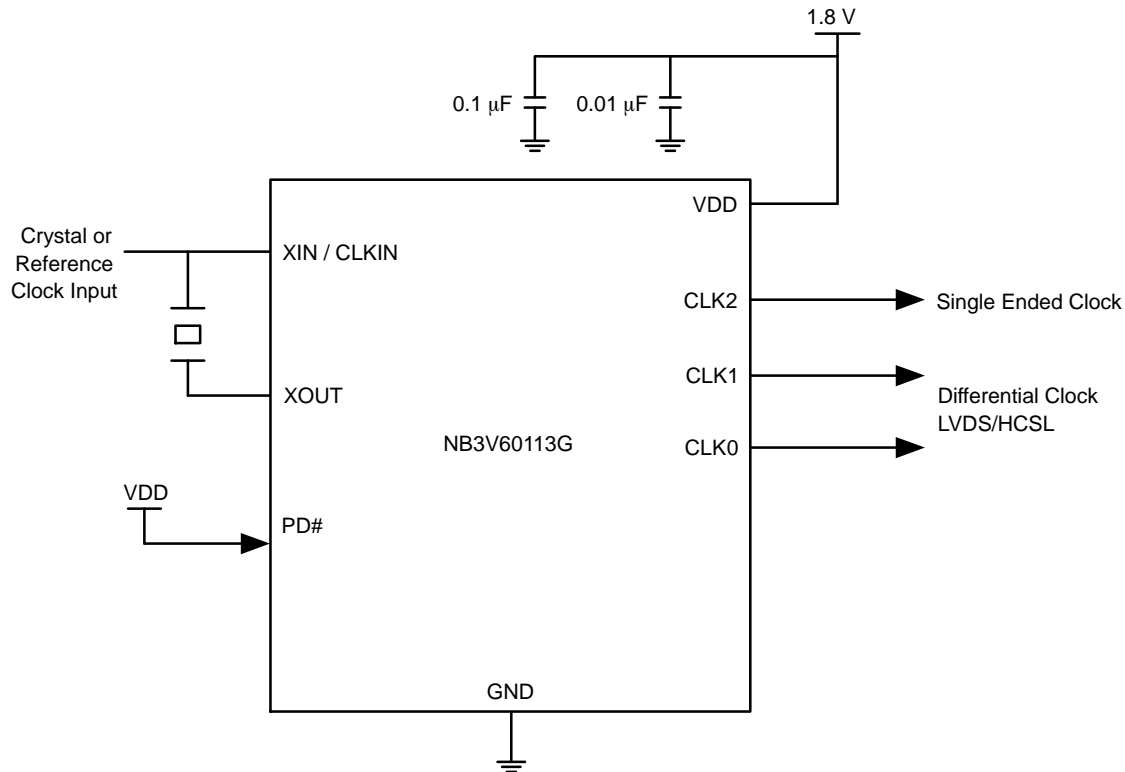

Figure 4. Application Setup for Differential Output Configuration

Programmable Output Drive

The drive strength or output current of each of the LVC MOS clock outputs is programmable. For V_{DD} of 1.8 V four distinct levels of LVC MOS output drive strengths can be selected as mentioned in the DC Electrical Characteristics. This feature provides further load drive and signal conditioning as per the application requirement.

PLL BYPASS Mode

PLL Bypass mode can be used to buffer the input clock on any of the outputs or all of the outputs. Any of the clock outputs can be programmed to generate a copy of the input clock.

Output Inversion

All output clocks of the NB3V60113G can be phase inverted relative to each other. This feature can also be used in conjunction with the PLL Bypass mode.

Spread Spectrum Frequency Modulation

Spread spectrum is a technique using frequency modulation to achieve lower peak electromagnetic interference (EMI). It is an elegant solution compared to techniques of filtering and shielding. The NB3V60113G modulates the output of its PLL in order to “spread” the bandwidth of the synthesized clock, decreasing the peak amplitude at the center frequency and at the frequency’s harmonics. This results in significantly lower system EMI compared to the typical narrow band signal produced by oscillators and most clock generators. Lowering EMI by increasing a signal’s bandwidth is called ‘spread spectrum modulation’.

NB3V60113G

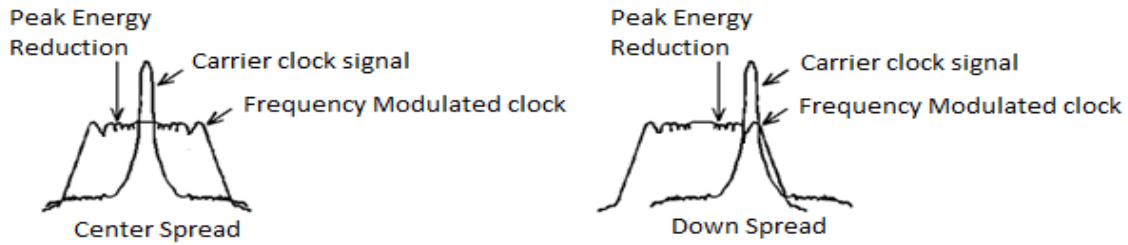

Figure 5. Frequency Modulation or Spread Spectrum Clock for EMI Reduction

The outputs of the NB3V60113G can be programmed to have either center spread from $\pm 0.125\%$ to $\pm 3\%$ or down spread from -0.25% to -4% . The programmable step size for spread spectrum deviation is 0.125% for center spread and 0.25% for down spread respectively. Additionally, the frequency modulation rate is also programmable. Frequency modulation from 30 kHz to 130 kHz can be selected. Spread spectrum, when on, applies to all the outputs of the device but not to output clocks that use the PLL bypass feature. There exists a tradeoff between the input clock frequency and the desired spread spectrum profile. For certain combinations of input frequency and modulation rate, the device operation could be unstable and should be avoided. For spread spectrum applications, the following limits are recommended:

$$F_{in} (\text{Min}) = 6.75 \text{ MHz}$$

$$F_{\text{mod}} (\text{range}) = 30 \text{ kHz to } 130 \text{ kHz}$$

$$F_{\text{mod}} (\text{Max}) = F_{in} / 225$$

For any input frequency selected, above limits must be observed for a good spread spectrum profile.

For example, the minimum recommended reference frequency for a modulation rate of 30 kHz would be $30 \text{ kHz} * 225 = 6.75 \text{ MHz}$. For 27 MHz, the maximum recommended modulation rate would be $27 \text{ MHz} / 225 = 120 \text{ kHz}$.

Control Inputs

Power Down

Power saving mode can be activated through the power down PD# input pin. This input is an LVCMOS active Low Master Reset that disables the device and sets outputs Low. By default it has an internal pull-down resistor. The chip functions are disabled by default and when PD# pin is pulled high the chip functions are activated.

Configuration Space

NB3V60113G has one Configuration. Table 4 shows an example of device configuration.

Table 4. EXAMPLE CONFIGURATION

Input Frequency	Output Frequency	VDD	SS%	SS Mod Rate	Output Drive	Output Inversion	Output Enable	PLL Bypass	Notes
24 MHz	CLK0 = 33 MHz CLK1 = 12 MHz CLK2 = 24 MHz	1.8 V	-0.5%	100 kHz	CLK0 = 8 mA CLK1 = 4 mA CLK2 = 2 mA	CLK0 = N CLK1 = N CLK2 = Y	CLK0 = Y CLK1 = Y CLK2 = Y	CLK0 = N CLK1 = N CLK2 = Y	CLK2 Ref clk

Default Device State

The NB3V60113G parts shipped from ON Semiconductor are blank, with no inputs/outputs programmed. These need to be programmed by the field sales or distribution or by the user themselves before they can be used. Programmable clock software downloadable from the ON Semiconductor

website can be used along with the programming kit to achieve this purpose. For mass production, parts can be programmed with a customer qualified configuration and sourced from ON Semiconductor as a dash part number (Eg. NB3V60113G-01).

Table 5. ATTRIBUTES

Characteristic	Value
ESD Protection Human Body Model	2 kV
Internal Input Default State Pull up/ down Resistor	50 kΩ
Moisture Sensitivity, Indefinite Time Out of Dry Pack (Note 1)	MSL1
Flammability Rating Oxygen Index: 28 to 34	UL 94 V-0 @ 0.125 in
Transistor Count	130 k
Meets or exceeds JEDEC Spec EIA/JESD78 IC Latchup Test	

1. For additional information, see Application Note AND8003/D.

Table 6. ABSOLUTE MAXIMUM RATING (Note 2)

Symbol	Parameter	Rating	Unit
V _{DD}	Positive power supply with respect to Ground	-0.5 to +4.6	V
V _I	Input Voltage with respect to chip ground	-0.5 to V _{DD} + 0.5	V
T _A	Operating Ambient Temperature Range (Industrial Grade)	-40 to +85	°C
T _{STG}	Storage temperature	-65 to +150	°C
T _{SOL}	Max. Soldering Temperature (10 sec)	265	°C
θ _{JA}	Thermal Resistance (Junction-to-ambient) (Note 3)	0 lfpm 500 lfpm	°C/W °C/W
θ _{JC}	Thermal Resistance (Junction-to-case)	35 to 40	°C/W
T _J	Junction temperature	125	°C

Stresses exceeding those listed in the Maximum Ratings table may damage the device. If any of these limits are exceeded, device functionality should not be assumed, damage may occur and reliability may be affected.

- Maximum ratings applied to the device are individual stress limit values (not normal operating conditions) and not valid simultaneously. If stress limits are exceeded device functional operation is not implied, damage may occur and reliability may be affected.
- JEDEC standard multilayer board – 2S2P (2 signal, 2 power). ESD51.7 type board. Back side Copper heat spreader area 100 sq mm, 2 oz (0.070 mm) copper thickness.

Table 7. RECOMMENDED OPERATION CONDITIONS

Symbol	Parameter	Condition	Min	Typ	Max	Unit
V _{DD}	Core Power Supply Voltage	1.8 V operation	1.7	1.8	1.9	V
CL	Clock output load capacitance for LVC MOS clock	f _{out} < 100 MHz f _{out} ≥ 100 MHz			15 5	pF pF
f _{clk} in	Crystal Input Frequency Reference Clock Frequency	Fundamental Crystal Single ended clock Input	3 3		50 200	MHz
C _X	XIN / XOUT pin stray Capacitance	Note 4		4.5		pF
C _{XL}	Crystal Load Capacitance			10		pF
ESR	Crystal ESR				150	Ω

Functional operation above the stresses listed in the Recommended Operating Ranges is not implied. Extended exposure to stresses beyond the Recommended Operating Ranges limits may affect device reliability.

- The XIN / XOUT pin stray capacitance needs to be subtracted from crystal load capacitance (along with PCB and trace capacitance) while selecting appropriate load for the crystal in order to get minimum ppm error.

NB3V60113G

Table 8. DC ELECTRICAL CHARACTERISTICS ($V_{DD} = 1.8 \text{ V} \pm 0.1 \text{ V}$; $GND = 0 \text{ V}$, $T_A = -40^\circ\text{C}$ to 85°C , Notes 5, 14)

Symbol	Parameter	Condition	Min	Typ	Max	Unit
$I_{DD_1.8V}$	Power Supply current for core	Configuration Dependent. $V_{DD} = 1.8 \text{ V}$, $T_A = 25^\circ\text{C}$, XIN/CLKIN = 25 MHz (XTAL), CLK[0:2] = 100 MHz, 8 mA output drive		13		mA
I_{PD}	Power Down Supply Current	PD# is Low to make all outputs OFF			20	μA
V_{IH}	Input HIGH Voltage	Pin XIN	$0.65 V_{DD}$		V_{DD}	V
		Pin PD#	$0.85 V_{DD}$		V_{DD}	
V_{IL}	Input LOW Voltage	Pin XIN	0		$0.35 V_{DD}$	V
		Pin PD#	0		$0.15 V_{DD}$	
Z_o	Nominal Output Impedance	Configuration Dependent. 8 mA drive		22		Ω
$R_{PUP/PD}$	Internal Pull up/ Pull down resistor	$V_{DD} = 1.8 \text{ V}$		150		k Ω
Cprog	Programmable Internal Crystal Load Capacitance	Configuration Dependent	4.36		20.39	pF
	Programmable Internal Crystal Load Capacitance Resolution			0.05		pF
Cin	Input Capacitance	Pin PD#		4	6	pF

LVC MOS OUTPUTS

V_{OH}	Output HIGH Voltage	$V_{DD} = 1.8 \text{ V}$	$I_{OH} = 8 \text{ mA}$ $I_{OH} = 4 \text{ mA}$ $I_{OH} = 2 \text{ mA}$ $I_{OH} = 1 \text{ mA}$	$0.75 \cdot V_{DD}$			V
V_{OL}	Output LOW Voltage	$V_{DD} = 1.8 \text{ V}$	$I_{OL} = 8 \text{ mA}$ $I_{OL} = 4 \text{ mA}$ $I_{OL} = 2 \text{ mA}$ $I_{OL} = 1 \text{ mA}$			$0.25 \cdot V_{DD}$	V
$I_{DD_LVC MOS}$	LVC MOS Output Supply Current	Configuration Dependent. $T_A = 25^\circ\text{C}$, CLK[0:2] = f _{out} in PLL bypass mode Measured on $V_{DD} = 1.8 \text{ V}$ f _{out} = 33.33 MHz, C _L = 5 pF f _{out} = 100 MHz, C _L = 5 pF f _{out} = 200 MHz, C _L = 5 pF			3 6.5 12		mA

HCSL OUTPUTS (Note 6)

V_{OH_HCSL}	Output HIGH Voltage (Note 7)	$V_{DD} = 1.8 \text{ V}$		700			mV
V_{OL_HCSL}	Output Low Voltage (Note 7)	$V_{DD} = 1.8 \text{ V}$		0			mV
V_{CROSS}	Crossing Point Voltage (Notes 8 and 9)	$V_{DD} = 1.8 \text{ V}$		250	350	450	mV
Delta V_{cross}	Change in Magnitude of V_{cross} for HCSL Output (Notes 8 and 10)	$V_{DD} = 1.8 \text{ V}$				150	mV
I_{DD_HCSL}	Measured on $V_{DD} = 1.8 \text{ V}$ with	f _{out} = 100 MHz, C _L = 2 pF f _{out} = 200 MHz, C _L = 2 pF			22		mA

NB3V60113G

Table 8. DC ELECTRICAL CHARACTERISTICS ($V_{DD} = 1.8 \text{ V} \pm 0.1 \text{ V}$; $GND = 0 \text{ V}$, $T_A = -40^\circ\text{C}$ to 85°C , Notes 5, 14)

Symbol	Parameter	Condition	Min	Typ	Max	Unit
LVDS OUTPUTS (Notes 8 and 11)						
V_{OD_LVDS}	Differential Output Voltage		250		450	mV
ΔV_{OD_LVDS}	Change in Magnitude of VOD for Complementary Output States		0		25	mV
V_{OS_LVDS}	Offset Voltage			1200		mV
ΔV_{OS_LVDS}	Change in Magnitude of VOS for Complementary Output States		0		25	mV
V_{OH_LVDS}	Output HIGH Voltage (Note 12)	$V_{DD} = 1.8 \text{ V}$		1425	1600	mV
V_{OL_LVDS}	Output LOW Voltage (Note 13)	$V_{DD} = 1.8 \text{ V}$	900	1075		mV
I_{DD_LVDS}		$f_{out} = 100 \text{ MHz}$ $f_{out} = 200 \text{ MHz}$		14		mA

NOTE: Device will meet the specifications after thermal equilibrium has been established when mounted in a test socket or printed circuit board with maintained transverse airflow greater than 500 lfm.

Product parametric performance is indicated in the Electrical Characteristics for the listed test conditions, unless otherwise noted. Product performance may not be indicated by the Electrical Characteristics if operated under different conditions.

5. Measurement taken with single ended clock outputs terminated with test load capacitance of 5 pF and 15 pF and differential clock terminated with test load of 2 pF. See Figures 7, 8 and 11.
6. Measurement taken with outputs terminated with $R_S = 0 \Omega$, $R_L = 50 \Omega$, with test load capacitance of 2 pF. See Figure 8. Guaranteed by characterization.
7. Measurement taken from single-ended waveform.
8. Measured at crossing point where the instantaneous voltage value of the rising edge of CLKx+ equals the falling edge of CLKx-.
9. Refers to the total variation from the lowest crossing point to the highest, regardless of which edge is crossing. Refers to all crossing points for this measurement.
10. Defined as the total variation of all crossing voltage of rising CLKx+ and falling CLKx-. This is maximum allowed variance in the VCROSS for any particular system.
11. LVDS outputs require 100 Ω receiver termination resistor between differential pair. See Figure 9.
12. $V_{OHmax} = V_{OSmax} + 1/2 V_{ODmax}$.
13. $V_{OLmax} = V_{OSmin} - 1/2 V_{ODmax}$.
14. Parameter guaranteed by design verification not tested in production.

NB3V60113G

Table 9. AC ELECTRICAL CHARACTERISTICS

($V_{DD} = 1.8\text{ V} \pm 0.1\text{ V}$, $GND = 0\text{ V}$, $T_A = -40^\circ\text{C}$ to 85°C , Notes 15, 16 and 19)

Symbol	Parameter	Conditions	Min	Typ	Max	Unit
f_{out}	Single Ended Output Frequency		0.008		200	MHz
f_{MOD}	Spread Spectrum Modulation Rate	$f_{clk} \geq 6.75\text{ MHz}$	30		130	kHz
SS	Percent Spread Spectrum (deviation from nominal frequency)	Down Spread	0		-4	%
		Center Spread	0		± 3	%
SSstep	Percent Spread Spectrum change step size	Down Spread step size		0.25		%
		Center Spread step size		0.125		%
SS _{RED}	Spectral Reduction, 3rd harmonic	@SS=-0.5%, $f_{out} = 100\text{ MHz}$, $f_{clk} = 25\text{ MHz}$ crystal, RES BW at 30 kHz, All Output Types		-10		dB
t_{PU}	Stabilization time from Power-up	$V_{DD} = 1.8\text{ V}$ with Frequency Modulation		3.0		ms
t_{PD}	Stabilization time from Power Down	Time from falling edge on PD# pin to tri-stated outputs (Asynchronous)		3.0		ms
Eppm	Synthesis Error	Configuration Dependent		0		ppm

SINGLE ENDED OUTPUTS ($V_{DD} = 1.8\text{ V} \pm 0.1\text{ V}$; $T_A = -40^\circ\text{C}$ to 85°C , Notes 15, 16 and 19)

$t_{JITTER-1.8\text{ V}}$	Period Jitter Peak-to-Peak	Configuration Dependent. 25 MHz xtal input, $f_{out} = 100\text{ MHz}$, SS off (Notes 17, 19 and 21, see Figure 12)		100		ps
	Cycle-Cycle Peak Jitter	Configuration Dependent. 25 MHz xtal input, $f_{out} = 100\text{ MHz}$, SS off (Notes 17, 19 and 21, see Figure 12)		100		ps
$t_r / t_f 1.8\text{ V}$	Rise/Fall Time	Measured between 20% to 80% with 15 pF load, $f_{out} = 100\text{ MHz}$, $V_{DD} = V_{DDO} = 1.8\text{ V}$, Max Drive Min Drive		1 2		ns
t_{DC}	Output Clock Duty Cycle	$V_{DD} = 1.8\text{ V}$; Duty Cycle of Ref clock is 50%				%
		PLL Clock Reference Clock	45 40	50 50	55 60	

DIFFERENTIAL OUTPUT (CLK1, CLK0) ($V_{DD} = 1.8\text{ V} \pm 0.1\text{ V}$; $T_A = -40^\circ\text{C}$ to 85°C , Notes 15, 19 and 20)

$t_{JITTER-1.8\text{ V}}$	Period Jitter Peak-to-Peak	Configuration Dependent. 25 MHz xtal input, $f_{out} = 100\text{ MHz}$, SS off, CLK = OFF (Notes 18, 19, and 21, see Figure 12)		100		ps
	Cycle-Cycle Peak to Peak Jitter	Configuration Dependent. 25 MHz xtal input, $f_{out} = 100\text{ MHz}$, SS off, CLK2 = OFF (Notes 18, 19, and 21, see Figure 12)		100		ps
$t_r 1.8\text{ V}$	Rise Time	Measured between 20% to 80% $V_{DD} = 1.8\text{ V}$ HCSL LVDS	175		700	ps
$t_f 1.8\text{ V}$	Fall Time	Measured between 20% to 80% $V_{DD} = 1.8\text{ V}$ HCSL LVDS	175		700	ps

NB3V60113G

Table 9. AC ELECTRICAL CHARACTERISTICS

($V_{DD} = 1.8\text{ V} \pm 0.1\text{ V}$, $GND = 0\text{ V}$, $T_A = -40^\circ\text{C}$ to 85°C , Notes 15, 16 and 19)

Symbol	Parameter	Conditions	Min	Typ	Max	Unit
DIFFERENTIAL OUTPUT (CLK1, CLK0) ($V_{DD} = 1.8\text{ V} \pm 0.1\text{ V}$; $T_A = -40^\circ\text{C}$ to 85°C , Notes 15, 19 and 20)						
t_{DC}	Output Clock Duty Cycle	$V_{DD} = 1.8\text{ V}$; Duty Cycle of Ref clock is 50%				%
		PLL Clock	45	50	55	
		Reference Clock	40	50	60	

NOTE: Device will meet the specifications after thermal equilibrium has been established when mounted in a test socket or printed circuit board with maintained transverse airflow greater than 500 lfm.

Product parametric performance is indicated in the Electrical Characteristics for the listed test conditions, unless otherwise noted. Product performance may not be indicated by the Electrical Characteristics if operated under different conditions.

15. Parameter guaranteed by design verification not tested in production.

16. Measurement taken from single ended clock terminated with test load capacitance of 5 pF and 15 pF and differential clock terminated with test load of 2 pF. See Figures 6, 7 and 10.

17. Measurement taken from single-ended waveform

18. Measurement taken from differential waveform

19. AC performance parameters like jitter change based on the output frequency, spread selection, power supply and loading conditions of the output. For application specific AC performance parameters, please contact ON Semiconductor.

20. Measured at $f_{out} = 100\text{ MHz}$, No Frequency Modulation, $f_{clkin} = 25\text{ MHz}$ fundamental mode crystal and output termination as described in Parameter Measurement Test Circuits

21. Period jitter Sampled with 10000 cycles, Cycle-cycle jitter sampled with 1000 cycles. Jitter measurement may vary. Actual jitter is dependent on Input jitter and edge rate, number of active outputs, inputs and output frequencies, supply voltage, temperature, and output load.

NB3V60113G

SCHEMATIC FOR OUTPUT TERMINATION

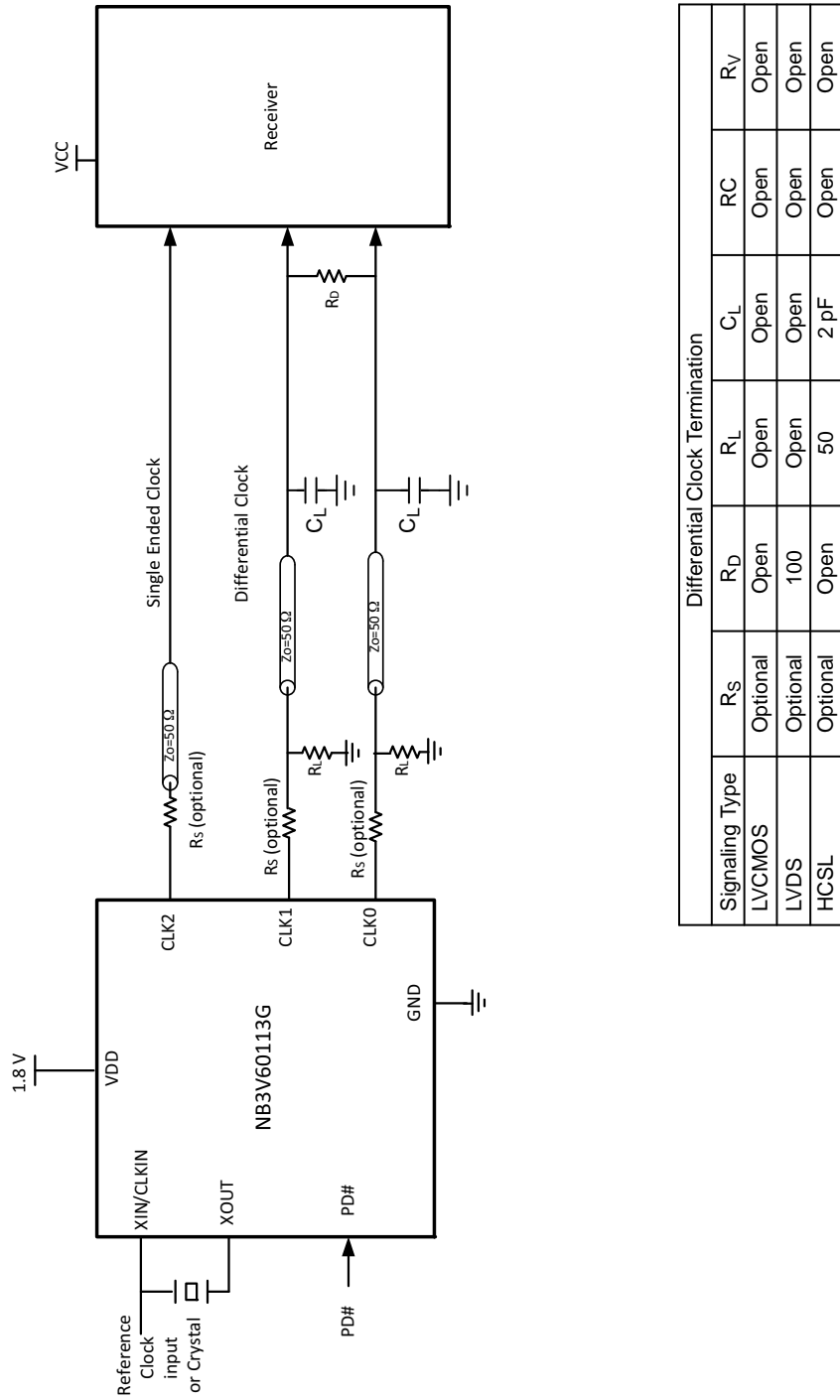

22. Receiver VCC must be at same supply potential as VDD for differential clock outputs.
 23. All resistor values are in ohms.

Figure 6. Typical Termination for Single-Ended and Differential Signaling Device Load

PARAMETER MEASUREMENT TEST CIRCUITS

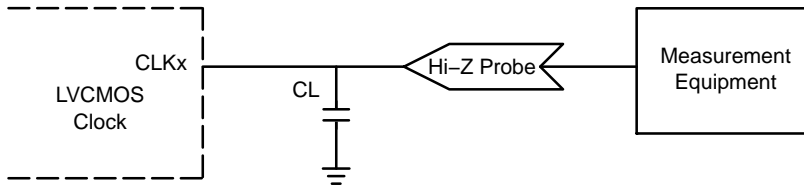

Figure 7. LVC MOS Parameter Measurement

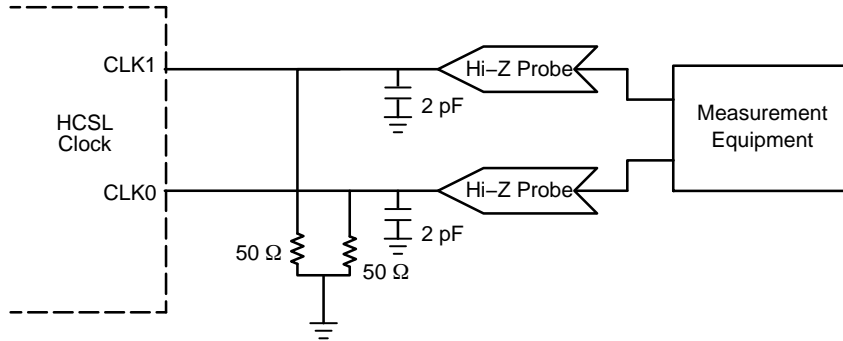

Figure 8. HCSL Parameter Measurement

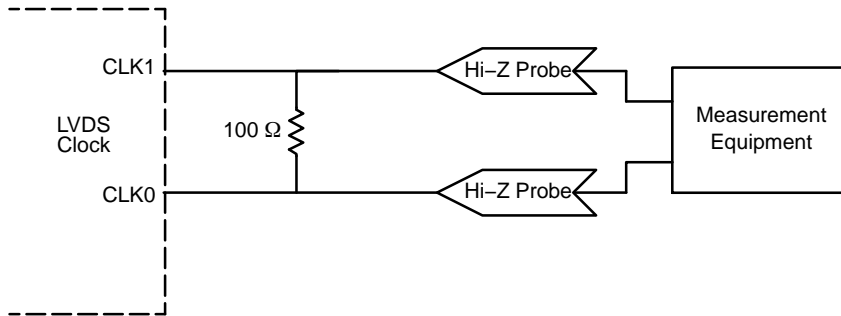

Figure 9. LVDS Parameter Measurement

TIMING MEASUREMENT DEFINITIONS

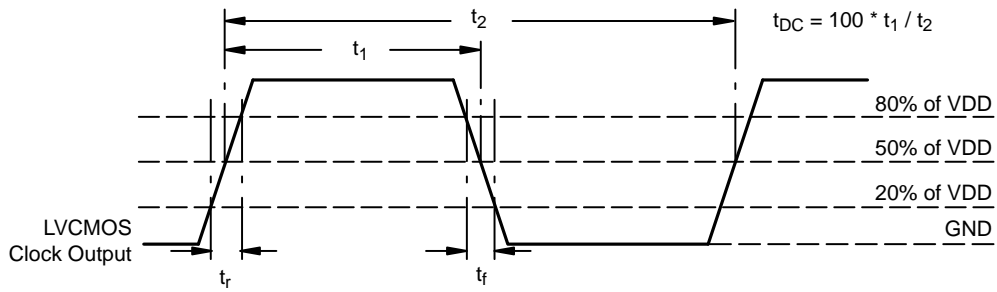

Figure 10. LVC MOS Measurement for AC Parameters

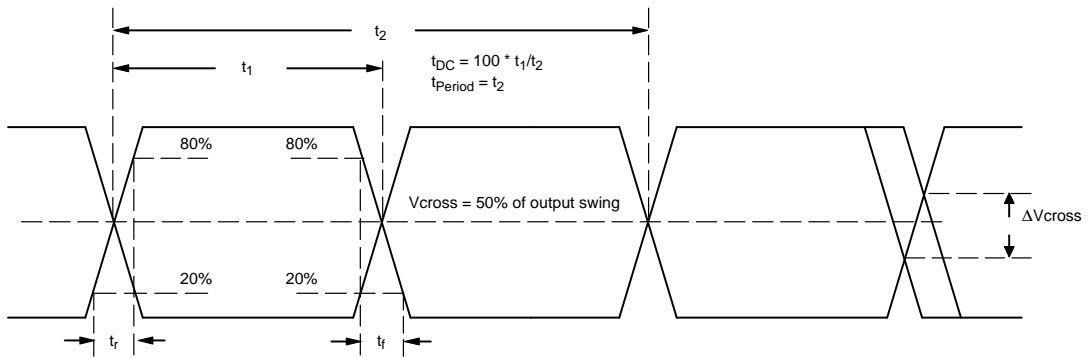

Figure 11. Differential Measurement for AC Parameters

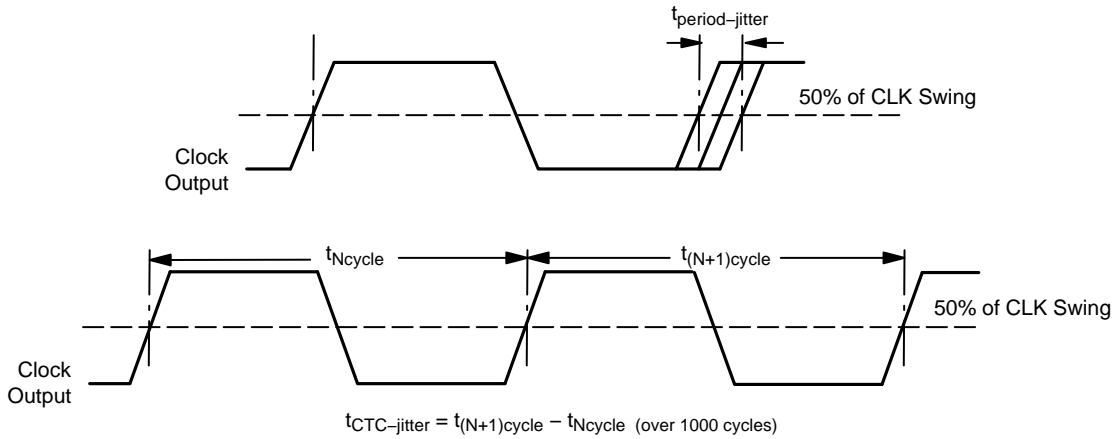

Figure 12. Period and Cycle-Cycle Jitter Measurement

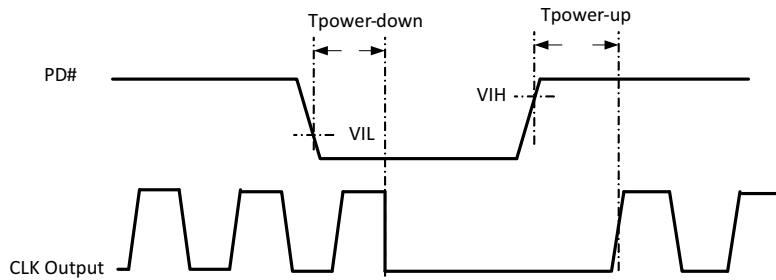

Figure 13. Output Enable/ Disable and Power Down Functions

APPLICATION GUIDELINES

Crystal Input Interface

Figure 14 shows the NB3V60113G device crystal oscillator interface using a typical parallel resonant fundamental mode crystal. A parallel crystal with loading capacitance $C_L = 18 \text{ pF}$ would use $C1 = 32 \text{ pF}$ and $C2 = 32 \text{ pF}$ as nominal values, assuming 4 pF of stray capacitance per line.

$$C_L = (C1 + C_{\text{stray}})/2; C1 = C2$$

The frequency accuracy and duty cycle skew can be fine-tuned by adjusting the C1 and C2 values. For example, increasing the C1 and C2 values will reduce the operational frequency. Note R1 is optional and may be 0Ω .

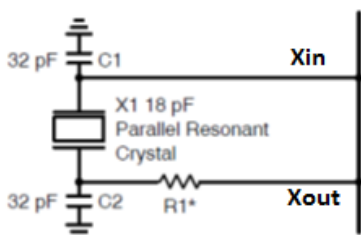

Figure 14. Crystal Interface Loading

Output Interface and Terminations

The NB3V60113G consists of a unique Multi Standard Output Driver to support LVCMOS, LVDS and HCSL standards. Termination techniques required for each of these standards are different to ensure proper functionality. The required termination changes must be considered and taken care of by the system designer.

LVCMOS Interface

LVCMOS output swings rail-to-rail up to V_{DD} supply and can drive up to 15 pF load at higher drive strengths. The output buffer's drive is programmable up to four steps, though the drive current will depend on the step setting as well as the V_{DD} supply voltage. (See Figure 15 and Table 10). Drive strength must be configured high for driving higher loads. The slew rate of the clock signal increases with higher output current drive for the same load. The software lets the user choose the load drive current value per LVCMOS output based on the V_{DD} supply selected.

Table 10. LVCMOS DRIVE LEVEL SETTINGS

VDD Supply	Load Current Setting 3 Max Load Current	Load Current Setting 2	Load Current Setting 1	Load Current Setting 0 Min Load Current
1.8 V	8 mA	4 mA	2 mA	1 mA

The load current consists of the static current component (varies with drive) and dynamic current component. For any supply voltage, the dynamic load current range per LVCMOS output can be approximated by formula –

$$I_{DD} = f_{\text{out}} * C_{\text{load}} * V_{DD}$$

C_{load} includes the load capacitor connected to the output, the pin capacitor posed by the output pin (typically 5 pF) and

the cap load posed by the receiver input pin. $C_{\text{load}} = (C_L + C_{\text{pin}} + C_{\text{in}})$

An optional series resistor R_s can be connected at the output for impedance matching, to limit the overshoots and ringings.

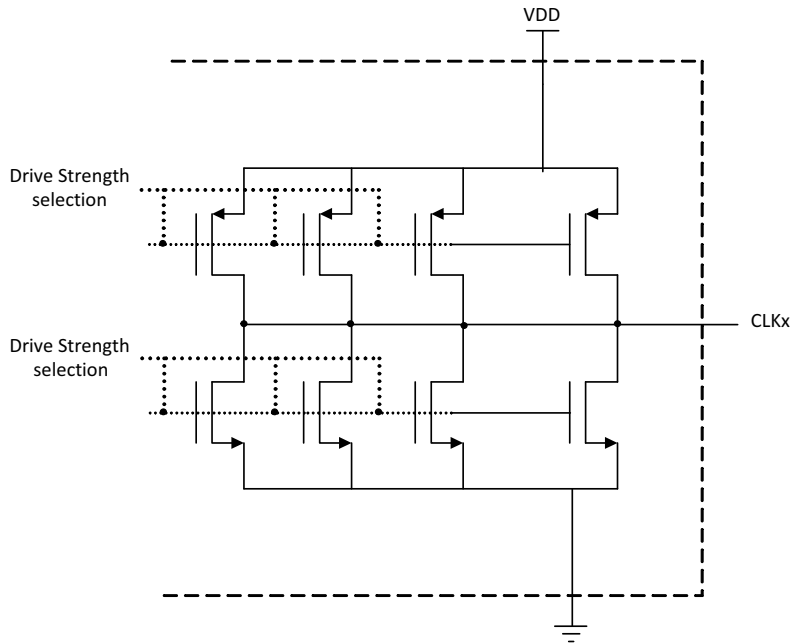

Figure 15. Simplified LVCMOS Output Structure

LVDS Interface

Differential signaling like LVDS has inherent advantage of common mode noise rejection and low noise emission, and thus a popular choice clock distribution in systems. TIA/EIA-644 or LVDS is a standard differential, point-to-point bus topology that supports fast switching speeds and has benefit of low power consumption. The driver consists of a low swing differential with constant current of 3.5 mA through the differential pair, and generates switching output voltage across a 100 Ω terminating resistor (externally connected or internal to the receiver). Power dissipation in LVDS standard $((3.5 \text{ mA})^2 \times 100 \text{ } \Omega = 1.2 \text{ mW})$ is thus much lower than other differential signalling standards.

A fan-out LVDS buffer (like ON Semiconductor’s NB6N1xS and NB6L1xS) can be used as an extension to provide clock signal to multiple LVDS receivers to drive multiple point-to-point links to receiving node.

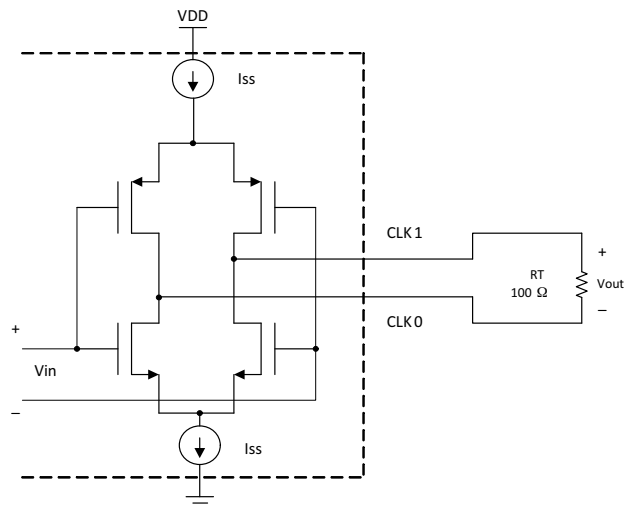

Figure 16. Simplified LVDS Output Structure with Termination

HCSL Termination

HCSL is a differential signaling standard commonly used in PCIe systems. The HCSL driver is typical 14.5 mA switched current open source output that needs a 50 Ω termination resistor to ground near the source, and generates 725 mV of signal swing. A series resistor (10 Ω to 33 Ω) is

optionally used to achieve impedance matching by limiting overshoot and ringing due to the rapid rise of current from the output driver. The open source driver has high internal impedance, thus a series resistor up to 33 Ω does not affect the signal integrity. This resistor can be avoided for low V_{DD} supply of operation, unless impedance matching requires it.

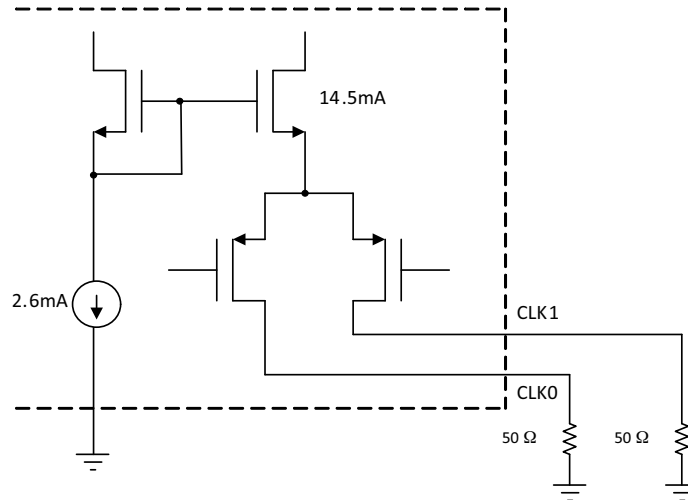

Figure 17. Simplified HCSL Output Structure with Termination

Field Programming Kit and Software

The NB3V60113G can be programmed by the user using the ‘Clock Cruiser Programmable Clock Kit’. This device uses the 8L daughter card on the hardware kit. To design a new clock, ‘Clock Cruiser Software’ is required to be installed from the ON Semiconductor website. The user manuals for the hardware kit Clock Cruiser Programmable Clock Kit and Clock Cruiser Software can be found following the link www.onsemi.com.

Recommendation for Clock Performance

Clock performance is specified in terms of Jitter in time the domain and Phase noise in frequency domain. Details and measurement techniques of Cycle-cycle jitter, period jitter, TIE jitter and Phase Noise are explained in application note AND8459/D.

In order to have a good clock signal integrity for minimum data errors, it is necessary to reduce the signal reflections. Reflection coefficient can be zero only when the source impedance equals the load impedance. Reflections are based on signal transition time (slew rate) and due to impedance mismatch. Impedance matching with proper termination is required to reduce the signal reflections. The amplitude of overshoots is due to the difference in impedance and can be minimized by adding a series resistor (R_s) near the output pin. Greater the difference in impedance, greater is the amplitude of the overshoots and subsequent ripples. The ripple frequency is dependant on the signal travel time from the receiver to the source. Shorter traces results in higher ripple frequency, as the trace gets longer the travel time increases, reducing the ripple frequency. The ripple

frequency is independent of signal frequency, and only depends on the trace length and the propagation delay. For eg. On an FR4 PCB with approximately 150 ps/ inch of propagation rate, on a 2 inch trace, the ripple frequency = 1 / (150 ps * 2 inch * 5) = 666.6 MHz; [5 = number of times the signal travels, 1 trip to receiver plus 2 additional round trips]

PCB traces should be terminated when trace length $tr/f / (2 * t_{prate})$; tr/f = rise/ fall time of signal, t_{prate} = propagation rate of trace.

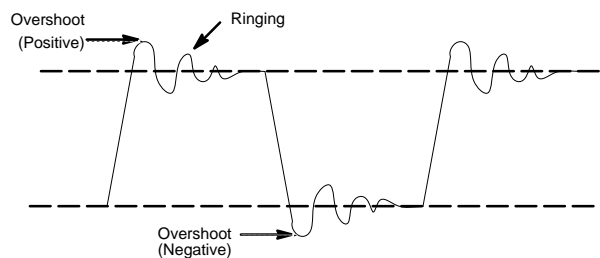

Figure 18. Signal Reflection Components

PCB Design Recommendation

For a clean clock signal waveform it is necessary to have a clean power supply for the device. The device must be isolated from system power supply noise. A 0.1 μF and a 2.2 μF decoupling capacitor should be mounted on the component side of the board as close to the VDD pin as possible. No vias should be used between the decoupling capacitor and VDD pin. The PCB trace to VDD pin and the

NB3V60113G

ground via should be kept thicker and as short as possible. All the VDD pins should have decoupling capacitors.

Stacked power and ground planes on the PCB should be large. Signal traces should be on the top layer with minimum vias and discontinuities and should not cross the reference planes. The termination components must be placed near the source or the receiver. In an optimum layout all components are on the same side of the board, minimizing vias through other signal layers.

Device Applications

The NB3V60113G is targeted mainly for the Consumer market segment and can be used as per the examples below.

Clock Generator

Consumer applications like a Set top Box, have multiple sub-systems and standard interfaces and require multiple reference clock sources at various locations in the system. This part can function as a clock generating IC for such applications generating a reference clock for interfaces like USB, Ethernet, Audio/Video, ADSL, PCI etc.

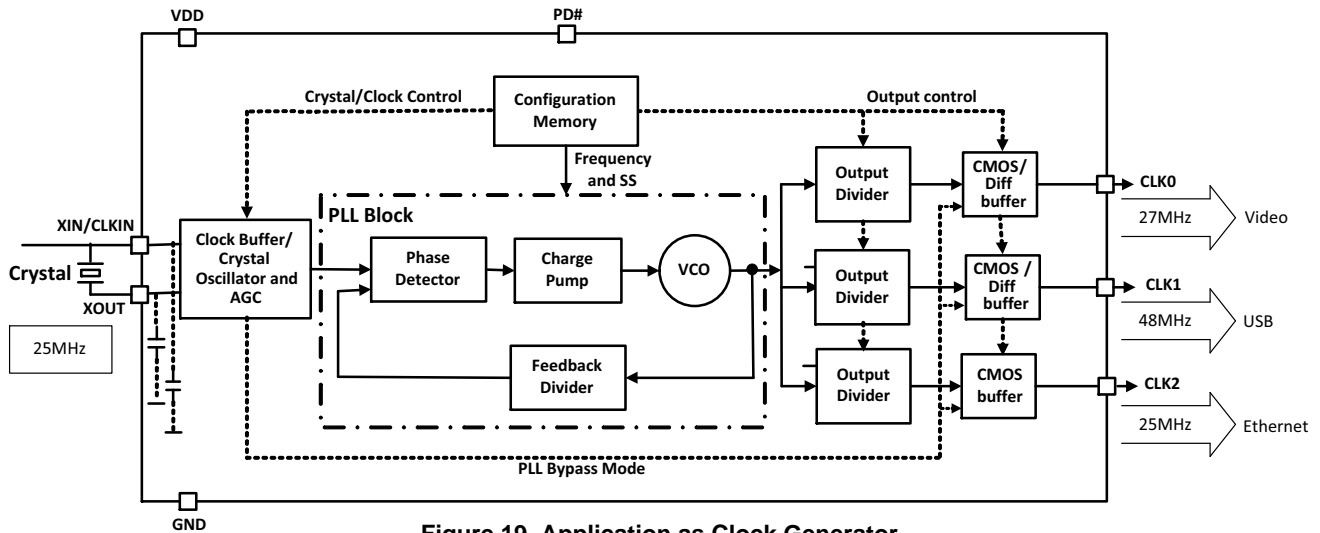

Figure 19. Application as Clock Generator

Buffer and Logic/Level Translator

The NB3V60113G is useful as a simple CMOS Buffer in PLL bypass mode. One or more outputs can use the PLL Bypass mode to generate the buffered outputs. If the PLL is configured to use spread spectrum, all outputs using PLL Bypass feature will not be subjected to the spread spectrum.

The device can be simultaneously used as logic translator for converting the LVCMOS input clock to HCSL or LVDS.

For instance this device can be used in applications like an LCD monitor, for converting the LVCMOS input clock to LVDS output.

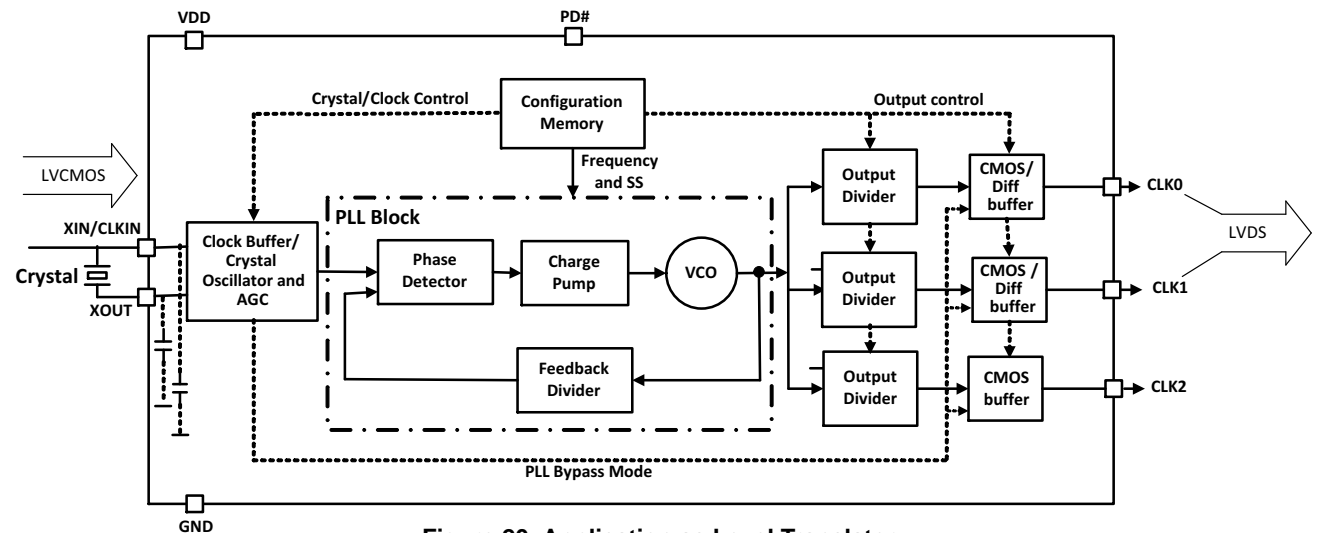

Figure 20. Application as Level Translator

NOTE: LVCMOS signal level cannot be translated to a higher level of LVCMOS voltage.

NB3V60113G

EMI Attenuator

Spread spectrum through frequency modulation technique enables the reduction of the EMI radiated from the high frequency clock signals by spreading the spectral energy to the nearby frequencies. While using frequency modulation, the same selection is applied to all the PLL

clock outputs (not bypass outputs) even if they are at different frequencies. In Figure 21, CLK0 uses the PLL and hence is subjected to the spread spectrum modulation while CLK1 and CLK2 use the PLL Bypass mode and hence are not subjected to the spread spectrum modulation.

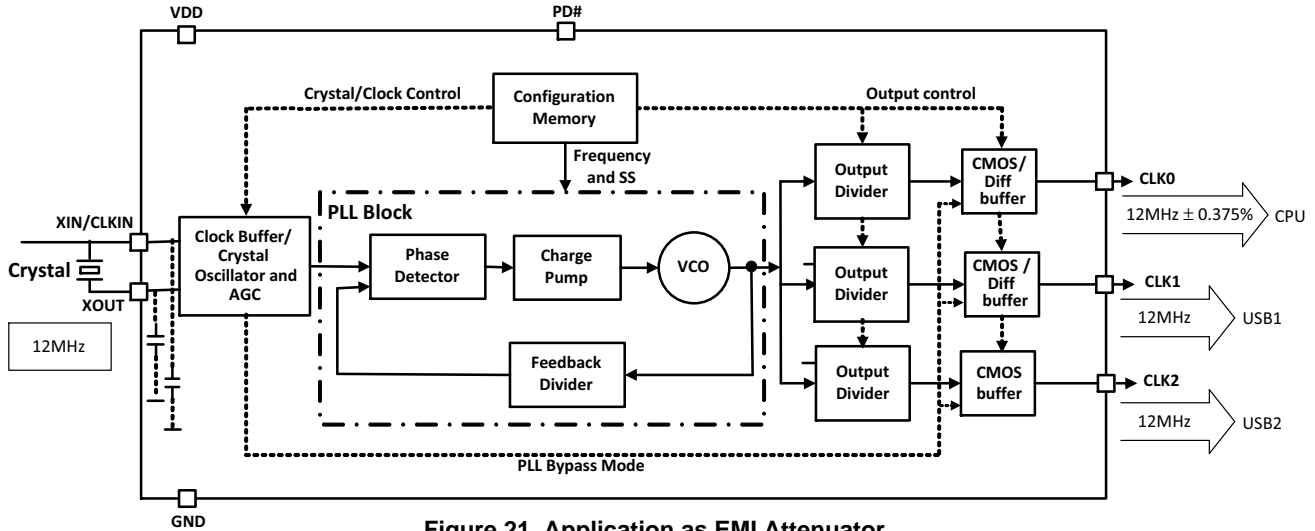

Figure 21. Application as EMI Attenuator

ORDERING INFORMATION

Device	Type	Package	Shipping†
NB3V60113G00MTR2G	Blank Device	DFN-8 (Pb-Free)	3000 / Tape & Reel
NB3V60113GxxMTR2G	Factory Pre-Programmed Device	DFN-8 (Pb-Free)	3000 / Tape & Reel

†For information on tape and reel specifications, including part orientation and tape sizes, please refer to our Tape and Reel Packaging Specifications Brochure, BRD8011/D.

NB3V60113G

PACKAGE DIMENSIONS

WDFN8 2x2, 0.5P
CASE 511AT
ISSUE O

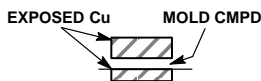
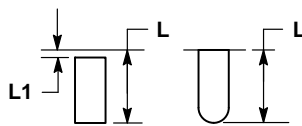
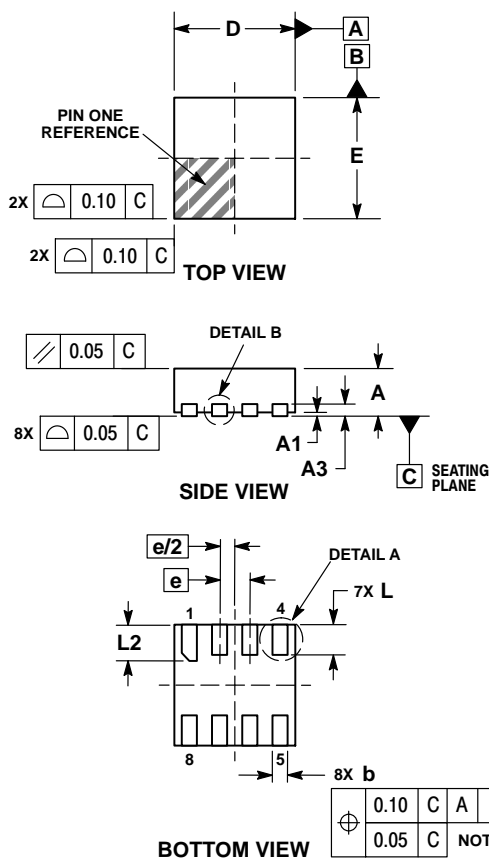

NOTES:

1. DIMENSIONING AND TOLERANCING PER ASME Y14.5M, 1994.
2. CONTROLLING DIMENSION: MILLIMETERS.
3. DIMENSION b APPLIES TO PLATED TERMINAL AND IS MEASURED BETWEEN 0.15 AND 0.30 MM FROM TERMINAL TIP.

DIM	MILLIMETERS	
	MIN	MAX
A	0.70	0.80
A1	0.00	0.05
A3	0.20	REF
b	0.20	0.30
D	2.00 BSC	
E	2.00 BSC	
e	0.50 BSC	
L	0.40	0.60
L1	---	0.15
L2	0.50	0.70

RECOMMENDED SOLDERING FOOTPRINT*

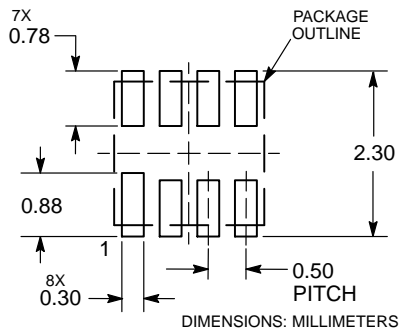

*For additional information on our Pb-Free strategy and soldering details, please download the ON Semiconductor Soldering and Mounting Techniques Reference Manual, SOLDERRM/D.

ON Semiconductor and the are registered trademarks of Semiconductor Components Industries, LLC (SCILLC) or its subsidiaries in the United States and/or other countries. SCILLC owns the rights to a number of patents, trademarks, copyrights, trade secrets, and other intellectual property. A listing of SCILLC's product/patent coverage may be accessed at www.onsemi.com/site/pdf/Patent-Marking.pdf. SCILLC reserves the right to make changes without further notice to any products herein. SCILLC makes no warranty, representation or guarantee regarding the suitability of its products for any particular purpose, nor does SCILLC assume any liability arising out of the application or use of any product or circuit, and specifically disclaims any and all liability, including without limitation special, consequential or incidental damages. "Typical" parameters which may be provided in SCILLC data sheets and/or specifications can and do vary in different applications and actual performance may vary over time. All operating parameters, including "Typicals" must be validated for each customer application by customer's technical experts. SCILLC does not convey any license under its patent rights nor the rights of others. SCILLC products are not designed, intended, or authorized for use as components in systems intended for surgical implant into the body, or other applications intended to support or sustain life, or for any other application in which the failure of the SCILLC product could create a situation where personal injury or death may occur. Should Buyer purchase or use SCILLC products for any such unintended or unauthorized application, Buyer shall indemnify and hold SCILLC and its officers, employees, subsidiaries, affiliates, and distributors harmless against all claims, costs, damages, and expenses, and reasonable attorney fees arising out of, directly or indirectly, any claim of personal injury or death associated with such unintended or unauthorized use, even if such claim alleges that SCILLC was negligent regarding the design or manufacture of the part. SCILLC is an Equal Opportunity/Affirmative Action Employer. This literature is subject to all applicable copyright laws and is not for resale in any manner.

PUBLICATION ORDERING INFORMATION

LITERATURE FULFILLMENT:
Literature Distribution Center for ON Semiconductor
19521 E. 32nd Pkwy, Aurora, Colorado 80011 USA
Phone: 303-675-2175 or 800-344-3860 Toll Free USA/Canada
Fax: 303-675-2176 or 800-344-3867 Toll Free USA/Canada
Email: orderlit@onsemi.com

N. American Technical Support: 800-282-9855 Toll Free USA/Canada
Europe, Middle East and Africa Technical Support:
Phone: 421 33 790 2910
Japan Customer Focus Center
Phone: 81-3-5817-1050

ON Semiconductor Website: www.onsemi.com
Order Literature: <http://www.onsemi.com/orderlit>

For additional information, please contact your local Sales Representative