

NB7HQ14M

2.5V 7GHz / 10Gbps Differential Input to 1.8V / 2.5V 1:4 CML Clock / Data Fanout Buffer w/ Selectable Input Equalizer

Multi-Level Inputs w/ Internal Termination

Description

The NB7HQ14M is a high performance differential 1:4 CML fanout buffer with a selectable Equalizer receiver. When placed in series with a Clock /Data path operating up to 7 GHz or 10 Gb/s, respectively, the NB7HQ14M inputs will compensate the degraded signal transmitted across a FR4 PCB backplane or cable interconnect and output four identical CML copies of the input signal. Therefore, the serial data rate is increased by reducing Inter-Symbol Interference (ISI) caused by losses in copper interconnect or long cables. The Equalizer ENable pin (EQEN) allows the IN/ \overline{IN} inputs to either flow through or bypass the Equalizer section. Control of the Equalizer function is realized by setting EQEN; When EQEN is set Low, the IN/ \overline{IN} inputs bypass the Equalizer. When EQEN is set High, the IN/ \overline{IN} inputs flow through the Equalizer. The default state at start-up is LOW. As such, NB7HQ14M is ideal for SONET, GigE, Fiber Channel, Backplane and other Clock/Data distribution applications.

The differential inputs incorporate internal 50 Ω termination resistors that are accessed through the VT pin. This feature allows the NB7HQ14M to accept various logic level standards, such as LVPECL, CML or LVDS. The outputs have the flexibility of being powered by either a 2.5 V or 1.8 V supply. The 1:4 fanout design was optimized for low output skew applications.

The NB7HQ14M is a member of the GigaComm™ family of high performance clock products.

Features

- Input Data Rate > 10 Gb/s
- Input Clock Frequency > 7 GHz
- 150 ps Typical Propagation Delay
- 35 ps Typical Rise and Fall Times
- < 15 ps Maximum Output Skew
- < 0.8 ps Maximum RMS Clock Jitter
- < 10 ps pp of Data Dependent Jitter
- Differential CML Outputs, 400 mV Peak-to-Peak, Typical
- Selectable Input Equalization
- Operating Range: $V_{CC} = 2.375 \text{ V}$ to 2.625 V , $V_{CCO} = 1.71 \text{ V}$ to 2.625 V
- Internal Input Termination Resistors, 50 Ω
- -40°C to $+85^\circ\text{C}$ Ambient Operating Temperature
- These are Pb-Free Devices



ON Semiconductor®

<http://onsemi.com>

MARKING DIAGRAM*

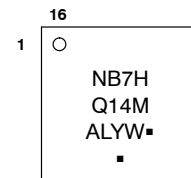

A	= Assembly Location
L	= Wafer Lot
Y	= Year
W	= Work Week
▪	= Pb-Free Package

(Note: Microdot may be in either location)

*For additional marking information, refer to Application Note AND8002/D.

SIMPLIFIED BLOCK DIAGRAM

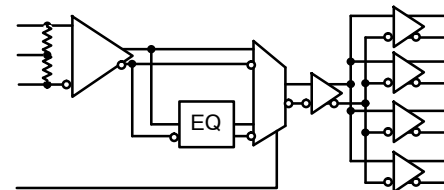

ORDERING INFORMATION

See detailed ordering and shipping information in the package dimensions section on page 9 of this data sheet.

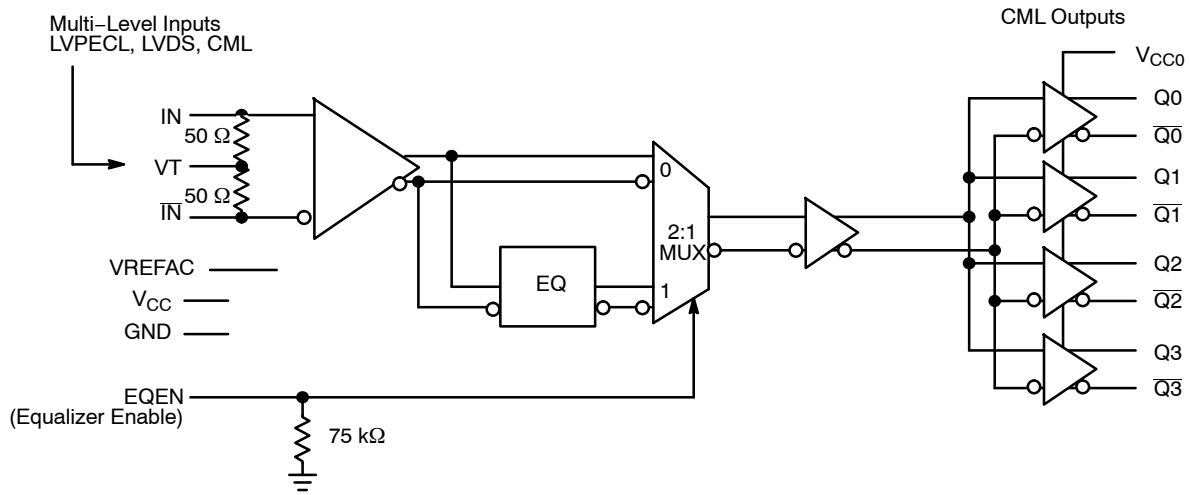

Figure 1. Detailed Block Diagram of NB7HQ14M

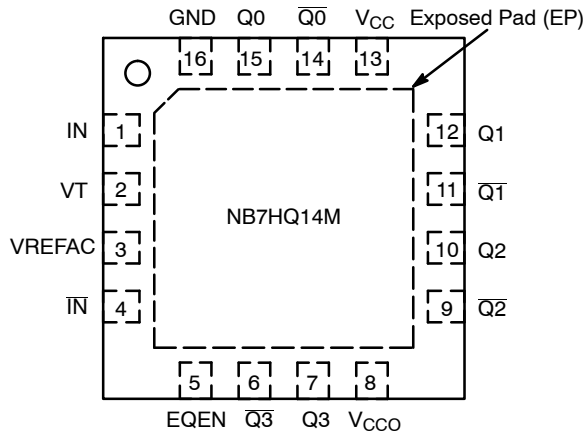

Table 1. EQUALIZER ENABLE FUNCTION

EQEN	Function
0	IN / \overline{IN} Inputs By-pass the Equalizer section
1	Inputs flow through the Equalizer

Figure 2. QFN-16 Pinout (Top View)

Table 2. PIN DESCRIPTION

Pin	Name	I/O	Description
1	IN	LVPECL, CML, LVDS Input	Non-inverted Differential Input. Note 1.
2	VT		Internal 100 Ω Center-tapped Termination Pin for IN / \overline{IN}
3	VREFAC		Output Voltage Reference for Capacitor-Coupled Inputs, only
4	\overline{IN}	LVPECL, CML, LVDS Input	Inverted Differential Input. Note 1.
5	EQEN	LVC MOS Input	Equalizer Enable Input; pin will default LOW when left open (has internal pull-down resistor)
6	$\overline{Q3}$	CML Output	Inverted Differential Output. Typically Terminated with 50 Ω Resistor to V_{CC} .
7	Q3	CML Output	Non-inverted Differential Output. Typically Terminated with 50 Ω Resistor to V_{CC} .
8	VCCO	-	1.8 V or 2.5 V Positive Supply Voltage for the Q_n / \overline{Q}_n CML Outputs
9	$\overline{Q2}$	CML Output	Inverted Differential Output. Typically Terminated with 50 Ω Resistor to V_{CC} .
10	Q2	CML Output	Non-inverted Differential Output. Typically Terminated with 50 Ω Resistor to V_{CC} .
11	$\overline{Q1}$	CML Output	Inverted Differential Output. Typically Terminated with 50 Ω Resistor to V_{CC} .
12	Q1	CML Output	Non-inverted Differential Output. Typically Terminated with 50 Ω Resistor to V_{CC} .
13	VCC	-	2.5 V Positive Supply Voltage for the core
14	$\overline{Q0}$	CML Output	Inverted Differential Output. Typically Terminated with 50 Ω Resistor to V_{CC} .
15	Q0	CML Output	Non-inverted Differential Output. Typically Terminated with 50 Ω Resistor to V_{CC} .
16	GND	-	Negative Supply Voltage
-	EP	-	The Exposed Pad (EP) on the QFN-16 package bottom is thermally connected to the die for improved heat transfer out of package. The exposed pad must be attached to a heat-sinking conduit. The pad is electrically connected to the die, and must be electrically and thermally connected to GND on the PC board.

1. In the differential configuration when the input termination pin (VT) is connected to a common termination voltage or left open, and if no signal is applied on IN / \overline{IN} input, then, the device will be susceptible to self-oscillation.
2. All VCC, VCCO and GND pins must be externally connected to a power supply for proper operation.

Table 3. ATTRIBUTES

Characteristics		Value
ESD Protection	Human Body Model Machine Model	> 2 kV > 200V
R_{PD} – EQEN Input Pulldown Resistor		75 k Ω
Moisture Sensitivity (Note 3)	16-QFN	Level 1
Flammability Rating	Oxygen Index: 28 to 34	UL 94 V-0 @ 0.125 in
Transistor Count		290
Meets or exceeds JEDEC Spec EIA/JESD78 IC Latchup Test		

3. For additional information, see Application Note AND8003/D.

Table 4. MAXIMUM RATINGS

Symbol	Parameter	Condition 1	Condition 2	Rating	Unit
V_{CC}	Positive Power Supply – Core	GND = 0 V		3.0	V
V_{CCO}	Positive Power Supply – Outputs	GND = 0 V		3.0	V
V_{IO}	Positive Input/Output Voltage	GND = 0 V		-0.5 to $V_{CC} + 0.5$	V
V_{INPP}	Differential Input Voltage $ I_N - \bar{I}_N $			1.89	V
I_{IN}	Input Current Through R_T (50 Ω Resistor)			± 40	mA
I_{OUT}	Output Current Through R_T (50 Ω Resistor)			± 40	mA
$I_{VFREFAC}$	VREFAC Sink/Source Current			± 1.5	mA
T_A	Operating Temperature Range	16 QFN		-40 to +85	$^{\circ}\text{C}$
T_{stg}	Storage Temperature Range			-65 to +150	$^{\circ}\text{C}$
θ_{JA}	Thermal Resistance (Junction-to-Ambient) (Note 4)	0 lfpm 500 lfpm	16 QFN 16 QFN	42 35	$^{\circ}\text{C}/\text{W}$ $^{\circ}\text{C}/\text{W}$
θ_{JC}	Thermal Resistance (Junction-to-Case) (Note 4)		16 QFN	4	$^{\circ}\text{C}/\text{W}$
T_{sol}	Wave Solder Pb-Free			265	$^{\circ}\text{C}$

Stresses exceeding Maximum Ratings may damage the device. Maximum Ratings are stress ratings only. Functional operation above the Recommended Operating Conditions is not implied. Extended exposure to stresses above the Recommended Operating Conditions may affect device reliability.

4. JEDEC standard multilayer board – 2S2P (2 signal, 2 power) with 8 filled thermal vias under exposed pad.

Table 5. DC CHARACTERISTICS, MULTI-LEVEL INPUTS $V_{CC} = 2.375\text{ V to }2.625\text{ V}$; $V_{CCO} = 1.71\text{ V to }2.625\text{ V}$; $GND = 0\text{ V}$;
 $T_A = -40^\circ\text{C to }85^\circ\text{C}$ (Note 5)

Symbol	Characteristic	Min	Typ	Max	Unit	
POWER SUPPLY / CURRENT						
V_{CC} V_{CCO}	Power Supply Voltage	$V_{CC} = 2.5\text{ V}$ $V_{CCO} = 2.5\text{ V}$ $V_{CCO} = 1.8\text{ V}$	2.375 2.375 1.71	2.5 2.5 1.8	2.625 2.625 1.89	V
I_{CC} I_{CCO}	Power Supply Current for V_{CC} (Inputs and Outputs Open) Power Supply Current for V_{CCO} (Inputs and Outputs Open)			95 65	135 85	mA

CML OUTPUTS (Note 6)

V_{OH}	Output HIGH Voltage	$V_{CCO} = 2.5\text{ V}$ $V_{CCO} = 1.8\text{ V}$	$V_{CCO} - 30$ 2470 1770	$V_{CCO} - 10$ 2490 1790	V_{CCO} 2500 1800	mV
V_{OL}	Output LOW Voltage	$V_{CCO} = 2.5\text{ V}$ $V_{CCO} = 1.8\text{ V}$	$V_{CCO} - 550$ 1950 1250	$V_{CCO} - 400$ 2100 1400	$V_{CCO} - 300$ 2200 1500	mV

DIFFERENTIAL INPUT DRIVEN SINGLE-ENDED (see Figure 5 & 7) (Note 7)

V_{IH}	Single-ended Input HIGH Voltage	$V_{th} + 100$		V_{CC}	mV
V_{IL}	Single-ended Input LOW Voltage	GND		$V_{th} - 100$	mV
V_{th}	Input Threshold Reference Voltage Range (Note 8)	1100		$V_{CC} - 100$	mV
V_{ISE}	Single-ended Input Voltage Amplitude ($V_{IH} - V_{IL}$)	200		2800	mV

VREFAC

V_{REFAC}	Output Reference Voltage @100 μA for capacitor-coupled inputs, only	$V_{CC} - 1325$	$V_{CC} - 1125$	$V_{CC} - 925$	mV
-------------	--	-----------------	-----------------	----------------	----

DIFFERENTIAL INPUTS DRIVEN DIFFERENTIALLY (see Figure 6 & 8) (Note 9)

V_{IHD}	Differential Input HIGH Voltage	1200		V_{CC}	mV
V_{ILD}	Differential Input LOW Voltage	0		$V_{IHD} - 100$	mV
V_{ID}	Differential Input Voltage ($V_{IHD} - V_{ILD}$)	100		1200	mV
V_{CMR}	Input Common Mode Range (Differential Configuration) (Note 10) (Figure 9)	1050		$V_{CC} - 50$	mV
I_{IH}	Input HIGH Current I_N / \bar{I}_N , (VT Open)	-150		150	μA
I_{IL}	Input LOW Current I_N / \bar{I}_N , (VT Open)	-150		150	μA

CONTROL INPUTS (EQEN)

V_{IH}	Input HIGH Voltage for Control Pins	$V_{CC} \times 0.65$		V_{CC}	V
V_{IL}	Input LOW Voltage for Control Pins	GND		$V_{CC} \times 0.35$	V
I_{IH}	Input HIGH Current	-150		150	μA
I_{IL}	Input LOW Current	-150		150	μA

TERMINATION RESISTORS

R_{TIN}	Internal Input Termination Resistor	45	50	55	Ω
R_{TOUT}	Internal Output Termination Resistor	45	50	55	Ω

NOTE: Device will meet the specifications after thermal equilibrium has been established when mounted in a test socket or printed circuit board with maintained transverse airflow greater than 500 lpm. Electrical parameters are guaranteed only over the declared operating temperature range. Functional operation of the device exceeding these conditions is not implied. Device specification limit values are applied individually under normal operating conditions and not valid simultaneously.

5. Input parameters vary 1:1 with V_{CC} . Output parameters vary 1:1 with V_{CCO} .

6. CML outputs loaded with $50\ \Omega$ to V_{CCO} for proper operation.

7. V_{th} , V_{IH} , V_{IL} , and V_{ISE} parameters must be complied with simultaneously.

8. V_{th} is applied to the complementary input when operating in single-ended mode.

9. V_{IHD} , V_{ILD} , V_{ID} and V_{CMR} parameters must be complied with simultaneously.

10. V_{CMR} min varies 1:1 with GND, V_{CMR} max varies 1:1 with V_{CC} . The V_{CMR} range is referenced to the crosspoint side of the differential input signal.

Table 6. AC CHARACTERISTICS $V_{CC} = 2.375\text{ V to }2.625\text{ V}$; $V_{CCO} = 1.71\text{ V to }2.625\text{ V}$; $GND = 0\text{ V}$; $T_A = -40^\circ\text{C to }85^\circ\text{C}$ (Note 11)

Symbol	Characteristic	Min	Typ	Max	Unit
f_{MAX}	Maximum Input Clock Frequency; $V_{OUT} \geq 200\text{ mV}$	7	10		GHz
$f_{DATAMAX}$	Maximum Operating Data Rate (PRBS23)	10	12		Gbps
V_{OUTPP}	Output Voltage Amplitude, EQEN = 0 or 1 (Note 15) $f_{in} \leq 7\text{ GHz}$ (See Figure 10)	200	400		mV
t_{PLH} , t_{PHL}	Propagation Delay IN to Q	120	170	225	ps
t_{SKEW}	Duty Cycle Skew (Note 12) Output – Output Within Device Skew Device to Device Skew		3	15 15 50	ps
t_{DC}	Output Clock Duty Cycle (Reference Duty Cycle = 50%) $f_{in} \leq 7\text{ GHz}$	40	50	60	%
Φ_N	Phase Noise, $f_{in} = 1\text{ GHz}$ 10 kHz 100 kHz 1 MHz 10 MHz 20 MHz 40 MHz		-135 -137 -149 -150 -150 -151		dBc
$t_{J\Phi N}$	Integrated Phase Jitter $f_{in} = 1\text{ GHz}$, 12 kHz – 20 MHz Offset (RMS)		50		fs
t_{JITTER}	RMS Random Clock Jitter (Note 13) $f_{in} \leq 7\text{ GHz}$ Peak-to-Peak Data Dependent Jitter (Note 14) $f_{in} \leq 10\text{ Gb/s}$ EQEN = 0 ($\leq 3''\text{ FR4}$) EQEN = 1 ($12''\text{ FR4}$)		0.2	0.8 10 10	ps rms ps pk-pk ps pk-pk
V_{INPP}	Input Voltage Swing/Sensitivity (Differential Configuration) (Note 15)	100		1200	mV
t_r t_f	Output Rise/Fall Times @ 1.0 GHz (20% – 80%) Q_x, \bar{Q}_x	15	30	45	ps

NOTE: Device will meet the specifications after thermal equilibrium has been established when mounted in a test socket or printed circuit board with maintained transverse airflow greater than 500 lpm. Electrical parameters are guaranteed only over the declared operating temperature range. Functional operation of the device exceeding these conditions is not implied. Device specification limit values are applied individually under normal operating conditions and not valid simultaneously.

- 11. Measured by forcing V_{INPP} 400mV from a 50% duty cycle clock source. All loading with an external $R_L = 50\ \Omega$ to V_{CCO} . Input edge rates 40 ps (20% – 80%).
- 12. Skew is measured between outputs under identical transitions and conditions @ 0.5 GHz. Duty cycle skew is measured between differential outputs using the deviations of the sum of T_{pw-} and T_{pw+} @ 0.5 GHz.
- 13. Additive RMS jitter with 50% duty cycle clock signal.
- 14. Additive peak-to-peak data dependent jitter with input NRZ data at PRBS23.
- 15. Input and output voltage swings are single-ended measurements operating in a differential mode.

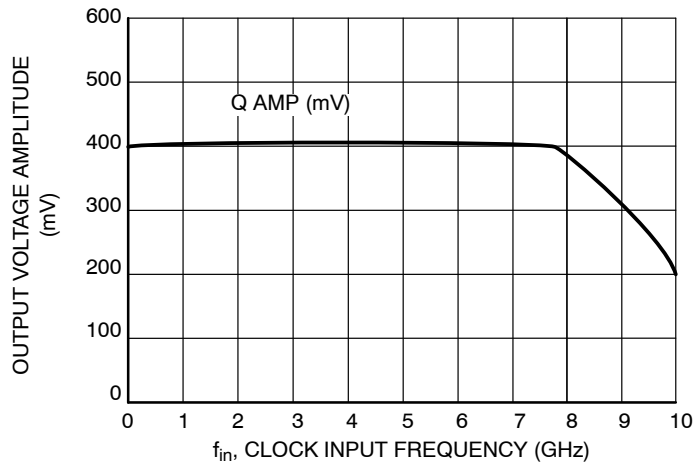

Figure 3. CLOCK Output Voltage Amplitude (V_{OUTPP}) vs. Input Frequency (f_{in}) at Ambient Temperature (Typical)

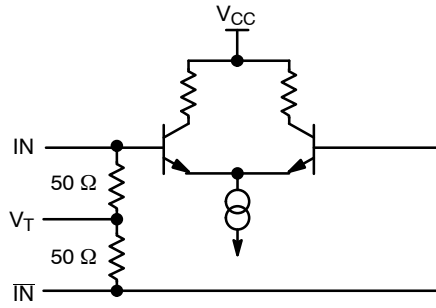

Figure 4. Input Structure

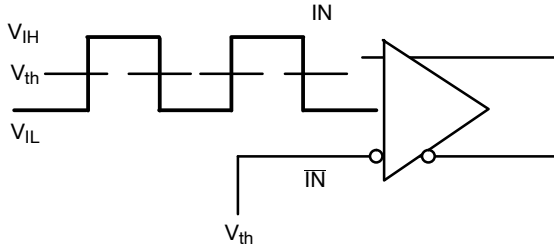

Figure 5. Differential Input Driven Single-Ended

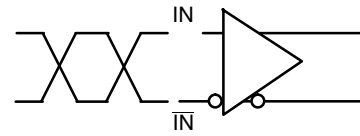

Figure 6. Differential Inputs Driven Differentially

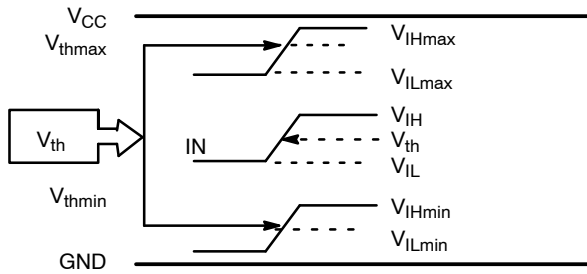

Figure 7. V_{th} Diagram

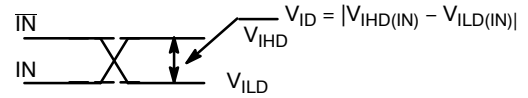

Figure 8. Differential Inputs Driven Differentially

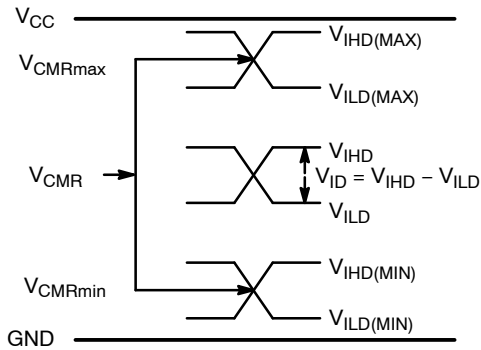

Figure 9. V_{CMR} Diagram

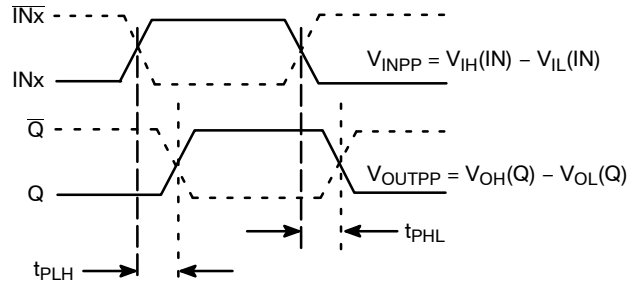

Figure 10. AC Reference Measurement

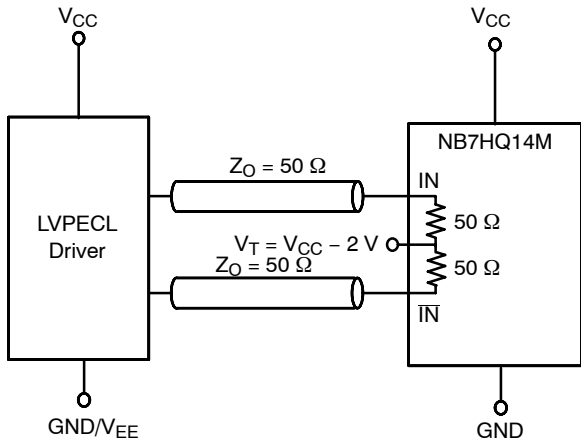

Figure 11. LVPECL Interface

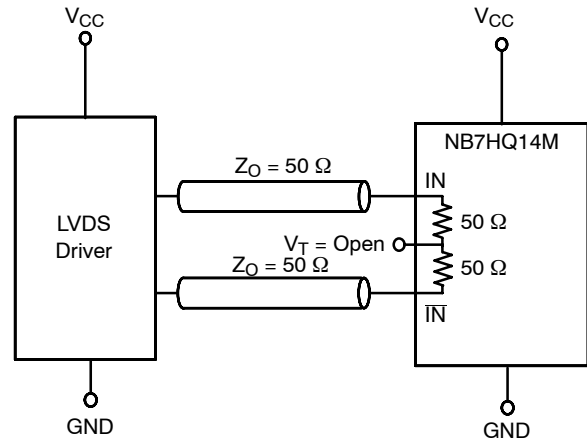

Figure 12. LVDS Interface

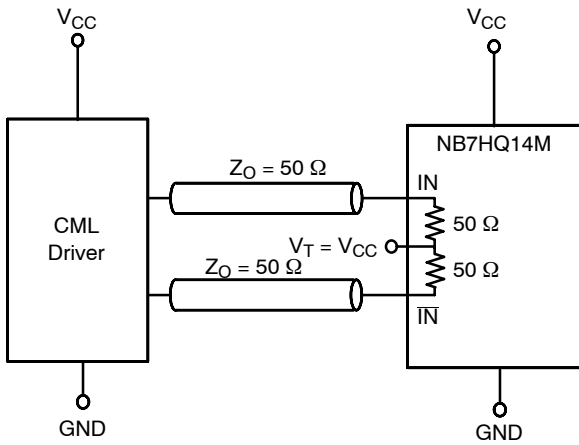

Figure 13. Standard 50 Ω Load CML Interface

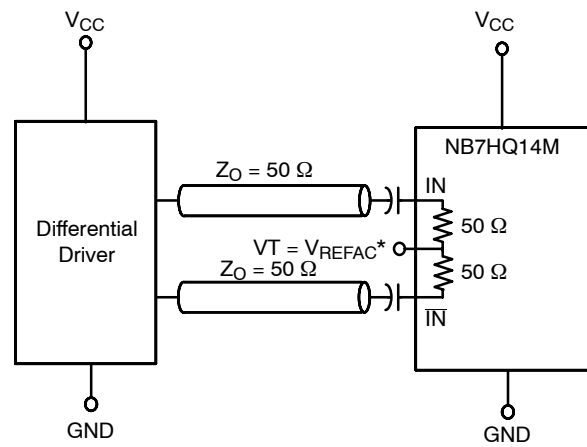

Figure 14. Capacitor-Coupled Differential Interface
(V_T Connected to V_{REFAC})

* V_{REFAC} bypassed to ground with a 0.01 μ F capacitor

www.DataSheet4U.com

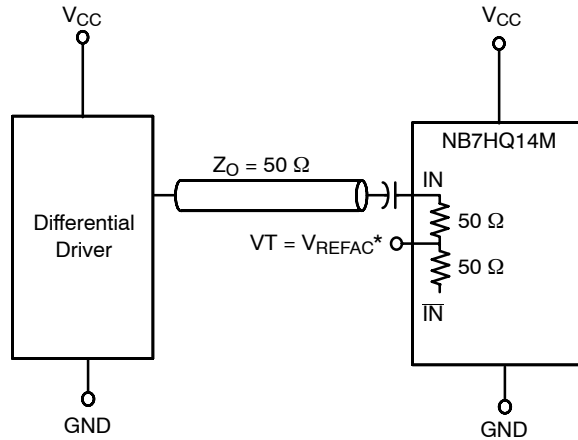

Figure 15. Capacitor-Coupled Single-Ended Interface
(V_T Connected to V_{REFAC})

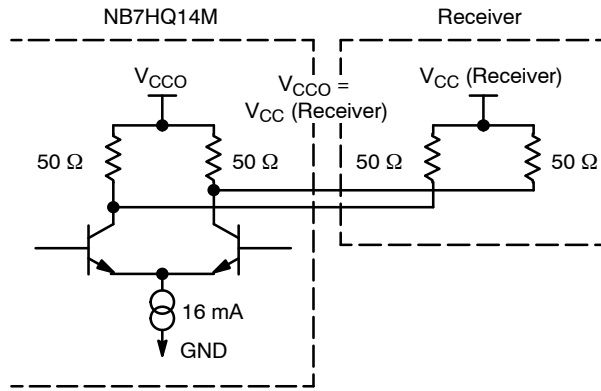

Figure 16. Typical CML Output Structure and Termination

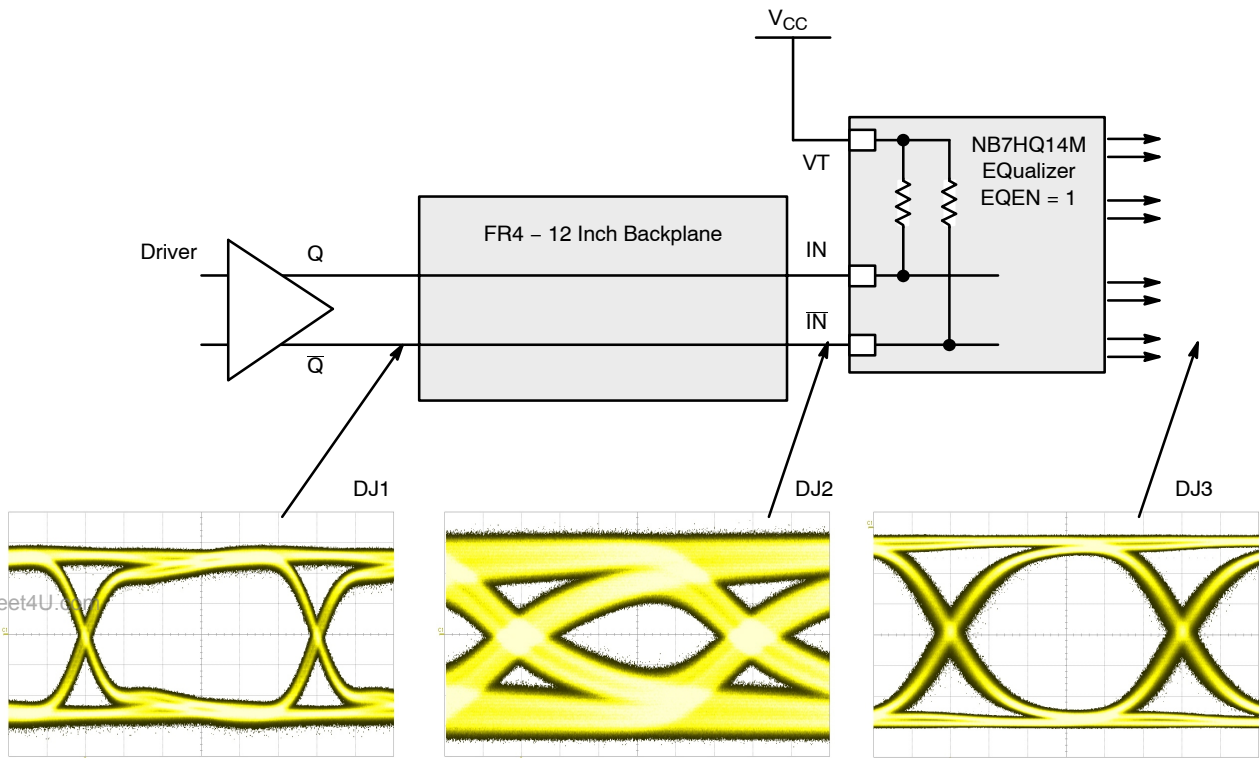

Figure 17. Typical NB7HQ14M Equalizer Application and Interconnect with PRBS23 pattern at 6.5 Gbps, EQEN = 1

ORDERING INFORMATION

Device	Package	Shipping [†]
NB7HQ14MMNG	QFN-16 (Pb-Free)	123 Units / Rail
NB7HQ14MMNHTBG	QFN-16 (Pb-Free)	100 / Tape & Reel
NB7HQ14MMNTXG	QFN-16 (Pb-Free)	3000 / Tape & Reel

[†]For information on tape and reel specifications, including part orientation and tape sizes, please refer to our Tape and Reel Packaging Specifications Brochure, BRD8011/D.

PACKAGE DIMENSIONS

16 PIN QFN
CASE 485G-01
ISSUE D

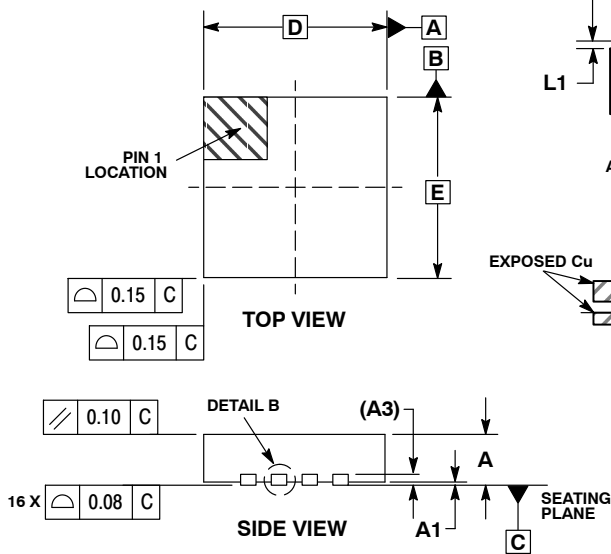

- NOTES:
1. DIMENSIONING AND TOLERANCING PER ASME Y14.5M, 1994.
 2. CONTROLLING DIMENSION: MILLIMETERS.
 3. DIMENSION b APPLIES TO PLATED TERMINAL AND IS MEASURED BETWEEN 0.25 AND 0.30 MM FROM TERMINAL.
 4. COPLANARITY APPLIES TO THE EXPOSED PAD AS WELL AS THE TERMINALS.
 5. L_{max} CONDITION CAN NOT VIOLATE 0.2 MM MINIMUM SPACING BETWEEN LEAD TIP AND FLAG

DIM	MILLIMETERS	
	MIN	MAX
A	0.80	1.00
A1	0.00	0.05
A3	0.20 REF	
b	0.18	0.30
D	3.00 BSC	
D2	1.65	1.85
E	3.00 BSC	
E2	1.65	1.85
e	0.50 BSC	
K	0.18 TYP	
L	0.30	0.50
L1	0.00	0.15

SOLDERING FOOTPRINT*

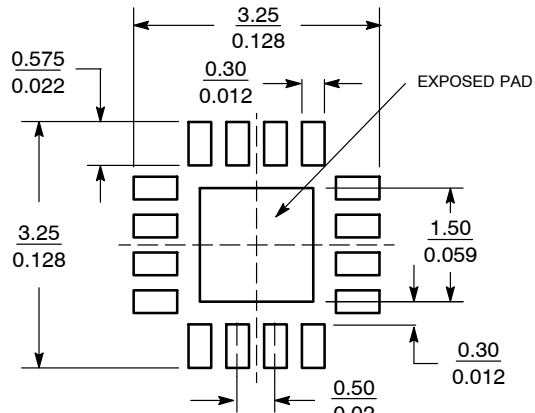
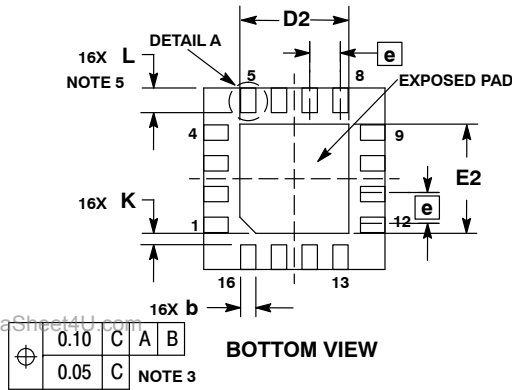

SCALE 10:1 (mm/inches)

*For additional information on our Pb-Free strategy and soldering details, please download the ON Semiconductor Soldering and Mounting Techniques Reference Manual, SOLDERRM/D.

GigaComm is a trademark of Semiconductor Components Industries, LLC (SCILLC).

ON Semiconductor and are registered trademarks of Semiconductor Components Industries, LLC (SCILLC). SCILLC reserves the right to make changes without further notice to any products herein. SCILLC makes no warranty, representation or guarantee regarding the suitability of its products for any particular purpose, nor does SCILLC assume any liability arising out of the application or use of any product or circuit, and specifically disclaims any and all liability, including without limitation special, consequential or incidental damages. "Typical" parameters which may be provided in SCILLC data sheets and/or specifications can and do vary in different applications and actual performance may vary over time. All operating parameters, including "Typicals" must be validated for each customer application by customer's technical experts. SCILLC does not convey any license under its patent rights nor the rights of others. SCILLC products are not designed, intended, or authorized for use as components in systems intended for surgical implant into the body, or other applications intended to support or sustain life, or for any other application in which the failure of the SCILLC product could create a situation where personal injury or death may occur. Should Buyer purchase or use SCILLC products for any such unintended or unauthorized application, Buyer shall indemnify and hold SCILLC and its officers, employees, subsidiaries, affiliates, and distributors harmless against all claims, costs, damages, and expenses, and reasonable attorney fees arising out of, directly or indirectly, any claim of personal injury or death associated with such unintended or unauthorized use, even if such claim alleges that SCILLC was negligent regarding the design or manufacture of the part. SCILLC is an Equal Opportunity/Affirmative Action Employer. This literature is subject to all applicable copyright laws and is not for resale in any manner.

PUBLICATION ORDERING INFORMATION

LITERATURE FULFILLMENT:
Literature Distribution Center for ON Semiconductor
P.O. Box 5163, Denver, Colorado 80217 USA
Phone: 303-675-2175 or 800-344-3860 Toll Free USA/Canada
Fax: 303-675-2176 or 800-344-3867 Toll Free USA/Canada
Email: orderlit@onsemi.com

N. American Technical Support: 800-282-9855 Toll Free USA/Canada
Europe, Middle East and Africa Technical Support:
Phone: 421 33 790 2910
Japan Customer Focus Center
Phone: 81-3-5773-3850

ON Semiconductor Website: www.onsemi.com
Order Literature: http://www.onsemi.com/orderlit
For additional information, please contact your local Sales Representative