

# NBXDBA009

## 3.3 V, 75 MHz / 150 MHz LVPECL Clock Oscillator

The NBXDBA009 dual frequency crystal oscillator (XO) is designed to meet today's requirements for 3.3 V LVPECL clock generation applications. The device uses a high Q fundamental crystal and Phase Lock Loop (PLL) multiplier to provide selectable 75 MHz or 150 MHz, ultra low jitter and phase noise LVPECL differential output.

This device is a member of ON Semiconductor's PureEdge™ clock family that provides accurate and precision clock solutions.

Available in 5 mm x 7 mm SMD (CLCC) package on 16 mm tape and reel in quantities of 1000.

### Features

- LVPECL Differential Output
- Uses High Q Fundamental Mode Crystal and PLL Multiplier
- Ultra Low Jitter and Phase Noise – 0.4 ps (12 kHz – 20 MHz)
- Selectable Output Frequency – 75 MHz (default) / 150 MHz
- Hermetically Sealed Ceramic SMD Package
- RoHS Compliant
- Operating Range 3.3 V  $\pm 10\%$
- Total Frequency Stability –  $\pm 50$  PPM
- This is a Pb-Free Device

### Applications

- SAS Gen2
- Serial ATA

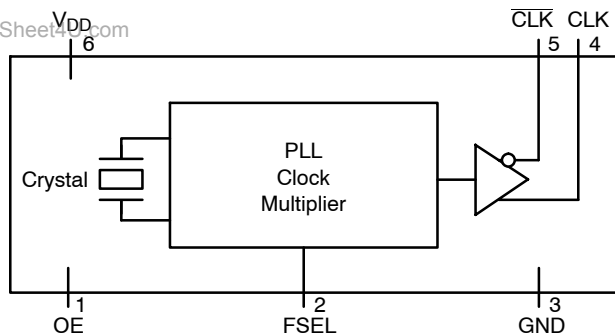
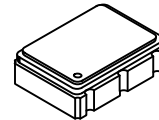

Figure 1. Simplified Logic Diagram



ON Semiconductor®

<http://onsemi.com>



6 PIN CLCC  
LN SUFFIX  
CASE 848AB

### MARKING DIAGRAM

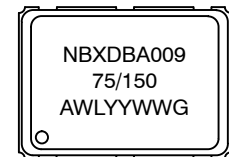

NBXDBA009 = NBXDBA009 ( $\pm 50$  PPM)  
75/150 = Output Frequency (MHz)  
A = Assembly Location  
WL = Wafer Lot  
YY = Year  
WW = Work Week  
G = Pb-Free Package

### ORDERING INFORMATION

Device	Package	Shipping†
NBXDBA009LN1TAG	CLCC-6 (Pb-Free)	1000/ Tape & Reel
NBXDBA009LNHTAG	CLCC-6 (Pb-Free)	100/ Tape & Reel

†For information on tape and reel specifications, including part orientation and tape sizes, please refer to our Tape and Reel Packaging Specification Brochure, BRD8011/D.

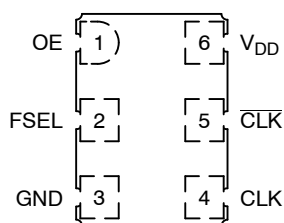

Figure 2. Pin Connections (Top View)

Table 1. PIN DESCRIPTION

Pin No.	Symbol	I/O	Description
1	OE	LVTTTL/LVCMOS Control Input	Output Enable Pin. When left floating pin defaults to logic HIGH and output is active. See OE pin description Table 2.
2	FSEL	LVTTTL/LVCMOS Control Input	Output Frequency Select Pin. Pin will default to logic HIGH when left open. See Output Frequency Select pin description Table 3.
3	GND	Power Supply	Ground 0 V
4	CLK	LVPECL Output	Non-Inverted Clock Output. Typically loaded with 50 Ω receiver termination resistor to $V_{TT} = V_{DD} - 2 V$ .
5	$\overline{CLK}$	LVPECL Output	Inverted Clock Output. Typically loaded with 50 Ω receiver termination resistor to $V_{TT} = V_{DD} - 2 V$ .
6	V <sub>DD</sub>	Power Supply	Positive power supply voltage. Voltage should not exceed 3.3 V ±10%.

Table 2. OUTPUT ENABLE TRI-STATE FUNCTION

OE Pin	Output Pins
Open	Active
HIGH Level	Active
LOW Level	High Z

Table 3. OUTPUT FREQUENCY SELECT

FSEL Pin	Output Frequency (MHz)
Open (pin will float high)	75
HIGH Level	75
LOW Level	150

Table 4. ATTRIBUTES

Characteristic	Value
Input Default State Resistor	170 kΩ
ESD Protection	Human Body Model Machine Model 2 kV 200 V
Meets or Exceeds JEDEC Standard EIA/JESD78 IC Latchup Test	

1. For additional Moisture Sensitivity information, refer to Application Note AND8003/D.

Table 5. MAXIMUM RATINGS

Symbol	Parameter	Condition 1	Condition 2	Rating	Units
V <sub>DD</sub>	Positive Power Supply	GND = 0 V		4.6	V
I <sub>out</sub>	LVPECL Output Current	Continuous Surge		25 50	mA
T <sub>A</sub>	Operating Temperature Range			-40 to +85	°C
T <sub>stg</sub>	Storage Temperature Range			-55 to +120	°C
T <sub>sol</sub>	Wave Solder	See Figure 6		260	°C

Stresses exceeding Maximum Ratings may damage the device. Maximum Ratings are stress ratings only. Functional operation above the Recommended Operating Conditions is not implied. Extended exposure to stresses above the Recommended Operating Conditions may affect device reliability.

**Table 6. DC CHARACTERISTICS** ( $V_{DD} = 3.3\text{ V} \pm 10\%$ ,  $GND = 0\text{ V}$ ,  $T_A = -40^\circ\text{C}$  to  $+85^\circ\text{C}$ ) (Note 2)

Symbol	Characteristic	Conditions	Min.	Typ.	Max.	Units
$I_{DD}$	Power Supply Current			79	100	mA
$V_{IH}$	OE and FSEL Input HIGH Voltage		2000		$V_{DD}$	mV
$V_{IL}$	OE and FSEL Input LOW Voltage		$GND - 300$		800	mV
$I_{IH}$	Input HIGH Current	OE	-100		+100	$\mu\text{A}$
		FSEL	-100		+100	
$I_{IL}$	Input LOW Current	OE	-100		+100	$\mu\text{A}$
		FSEL	-100		+100	
$V_{OH}$	Output HIGH Voltage	$V_{DD} = 3.3\text{ V}$	$V_{DD}-1195$ 2105		$V_{DD}-945$ 2355	mV
$V_{OL}$	Output LOW Voltage	$V_{DD} = 3.3\text{ V}$	$V_{DD}-1945$ 1355		$V_{DD}-1600$ 1700	mV
$V_{OUTPP}$	Output Voltage Amplitude			660		mV

NOTE: Device will meet the specifications after thermal equilibrium has been established when mounted in a test socket or printed circuit board with maintained transverse airflow greater than 500 lfpm. Electrical parameters are guaranteed only over the declared operating temperature range. Functional operation of the device exceeding these conditions is not implied. Device specification limit values are applied individually under normal operating conditions and not valid simultaneously.

2. Measurement taken with outputs terminated with 50 ohm to  $V_{DD}-2\text{ V}$ . See Figure 5.

**Table 7. AC CHARACTERISTICS** ( $V_{DD} = 3.3\text{ V} \pm 10\%$ ,  $GND = 0\text{ V}$ ,  $T_A = -40^\circ\text{C}$  to  $+85^\circ\text{C}$ ) (Note 3)

Symbol	Characteristic	Conditions	Min.	Typ.	Max.	Units
$f_{CLKOUT}$	Output Clock Frequency	FSEL = HIGH		75		MHz
		FSEL = LOW		150		
$\Delta f$	Frequency Stability – NBXDBA009	(Note 4)			$\pm 50$	ppm
$\Phi_{NOISE}$	Phase-Noise Performance $f_{CLKout} = 75\text{ MHz}/150\text{ MHz}$ (See Figures 3 and 4)	100 Hz of Carrier		-108/-102		dBc/Hz
		1 kHz of Carrier		-122/-116		dBc/Hz
		10 kHz of Carrier		-129/-122		dBc/Hz
		100 kHz of Carrier		-129/-122		dBc/Hz
		1 MHz of Carrier		-137/-131		dBc/Hz
		10 MHz of Carrier		-161/-158		dBc/Hz
$t_{jit}(\Phi)$	RMS Phase Jitter	12 kHz to 20 MHz		0.4	0.9	ps
$t_{jitter}$	Cycle to Cycle, RMS	1000 Cycles		2.3	8	ps
	Cycle to Cycle, Peak-to-Peak	1000 Cycles		13	30	ps
	Period, RMS	10,000 Cycles		1.3	4	ps
	Period, Peak-to-Peak	10,000 Cycles		8.7	20	ps
$t_{OE/OD}$	Output Enable/Disable Time				200	ns
$t_{DUTY\_CYCLE}$	Output Clock Duty Cycle (Measured at Cross Point)		48	50	52	%
$t_R$	Output Rise Time (20% and 80%)			250	400	ps
$t_F$	Output Fall Time (80% and 20%)			250	400	ps
$t_{start}$	Start-up Time			1	5	ms
	Aging	1 <sup>st</sup> Year			3	ppm
		Every Year After 1 <sup>st</sup>			1	ppm

NOTE: Device will meet the specifications after thermal equilibrium has been established when mounted in a test socket or printed circuit board with maintained transverse airflow greater than 500 lfpm. Electrical parameters are guaranteed only over the declared operating temperature range. Functional operation of the device exceeding these conditions is not implied. Device specification limit values are applied individually under normal operating conditions and not valid simultaneously.

3. Measurement taken with outputs terminated with 50 ohm to  $V_{DD}-2\text{ V}$ . See Figure 5.

4. Parameter guarantees 10 years of aging. Includes initial stability at 25°C, shock, vibration, and first year aging.

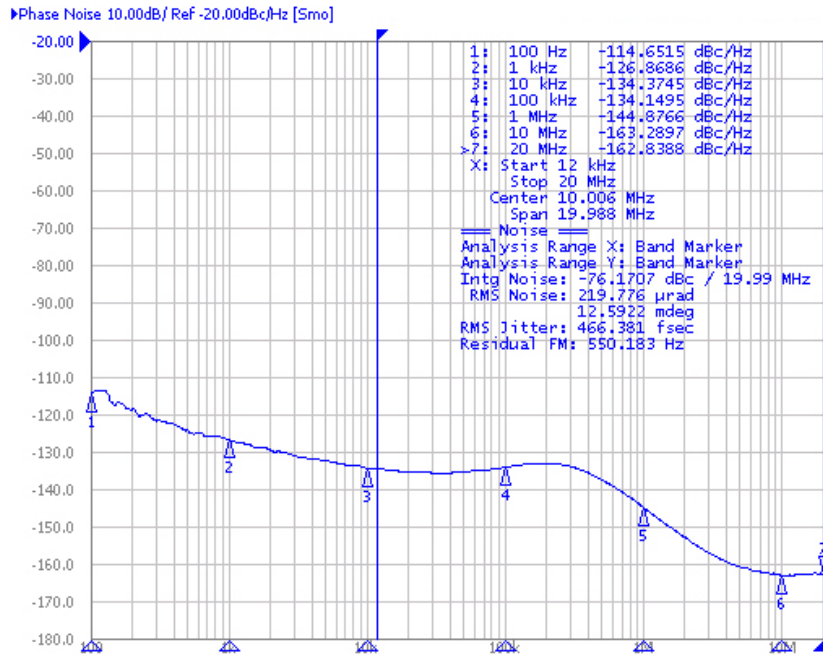

Figure 3. Typical Phase Noise Plot at 75 MHz

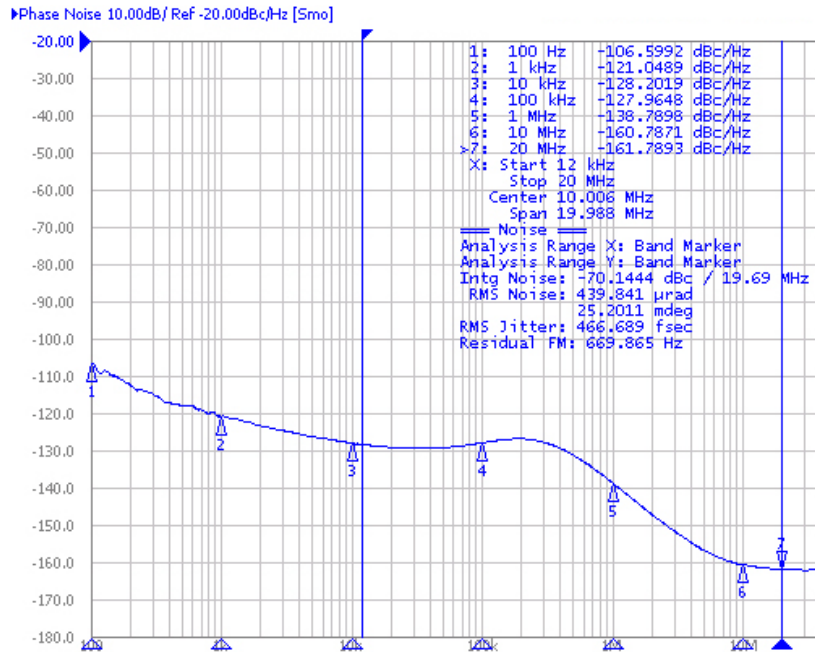

Figure 4. Typical Phase Noise Plot at 150 MHz

Table 8. RELIABILITY COMPLIANCE

Parameter	Standard	Method
Shock	Mechanical	MIL-STD-833, Method 2002, Condition B
Solderability	Mechanical	MIL-STD-833, Method 2003
Vibration	Mechanical	MIL-STD-833, Method 2007, Condition A
Solvent Resistance	Mechanical	MIL-STD-202, Method 215
Thermal Shock	Environment	MIL-STD-833, Method 1011, Condition A
Moisture Level Sensitivity	Environment	MSL1 260°C per IPC/JEDEC J-STD-020D

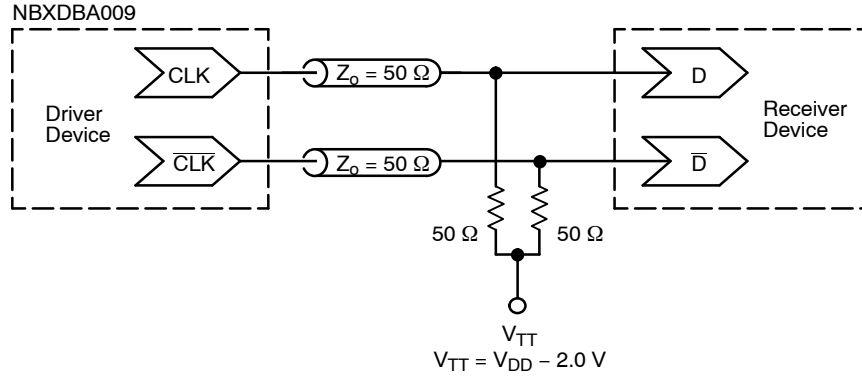

Figure 5. Typical Termination for Output Driver and Device Evaluation (See Application Note AND8020/D – Termination of ECL Logic Devices.)

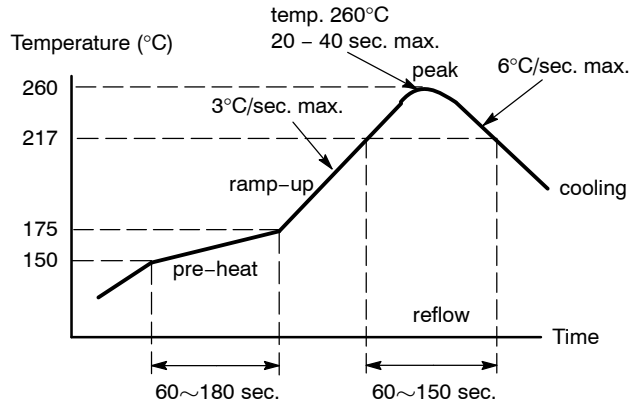
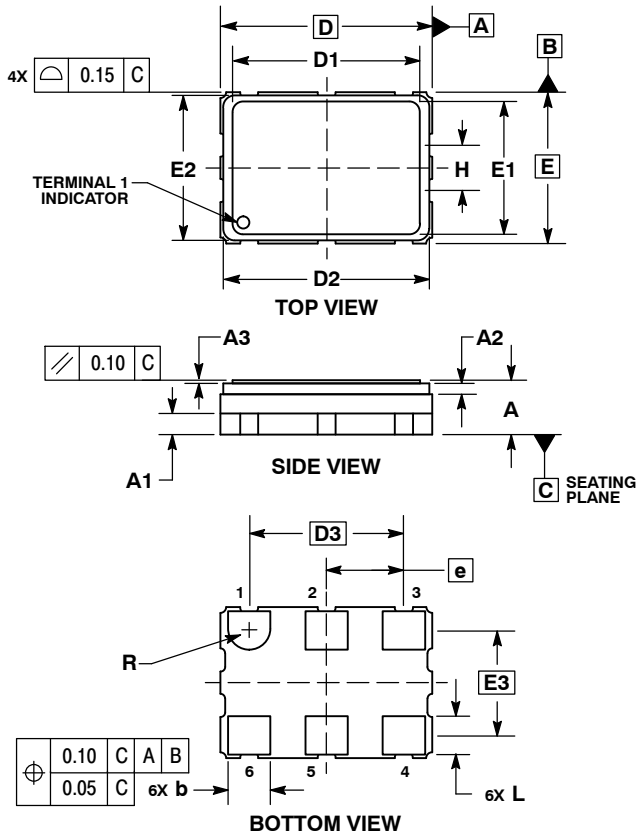

Figure 6. Recommended Reflow Soldering Profile

PACKAGE DIMENSIONS

6 PIN CLCC, 7x5, 2.54P  
CASE 848AB-01  
ISSUE C



NOTES:  
1. DIMENSIONING AND TOLERANCING PER ASME Y14.5M, 1994.  
2. CONTROLLING DIMENSION: MILLIMETERS.

DIM	MILLIMETERS		
	MIN	NOM	MAX
A	1.70	1.80	1.90
A1	0.70 REF		
A2	0.36 REF		
A3	0.08	0.10	0.12
b	1.30	1.40	1.50
D	7.00 BSC		
D1	6.17	6.20	6.23
D2	6.66	6.81	6.96
D3	5.08 BSC		
E	5.00 BSC		
E1	4.37	4.40	4.43
E2	4.65	4.80	4.95
E3	3.49 BSC		
e	2.54 BSC		
H	1.80 REF		
L	1.17	1.27	1.37
R	0.70 REF		

SOLDERING FOOTPRINT\*

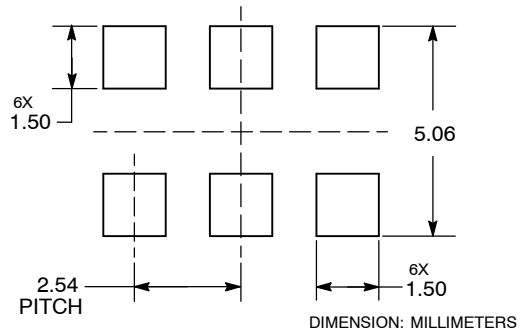

\*For additional information on our Pb-Free strategy and soldering details, please download the ON Semiconductor Soldering and Mounting Techniques Reference Manual, SOLDERRM/D.

PureEdge is a trademark of Semiconductor Components Industries, LLC (SCILLC).

ON Semiconductor and are registered trademarks of Semiconductor Components Industries, LLC (SCILLC). SCILLC reserves the right to make changes without further notice to any products herein. SCILLC makes no warranty, representation or guarantee regarding the suitability of its products for any particular purpose, nor does SCILLC assume any liability arising out of the application or use of any product or circuit, and specifically disclaims any and all liability, including without limitation special, consequential or incidental damages. "Typical" parameters which may be provided in SCILLC data sheets and/or specifications can and do vary in different applications and actual performance may vary over time. All operating parameters, including "Typicals" must be validated for each customer application by customer's technical experts. SCILLC does not convey any license under its patent rights nor the rights of others. SCILLC products are not designed, intended, or authorized for use as components in systems intended for surgical implant into the body, or other applications intended to support or sustain life, or for any other application in which the failure of the SCILLC product could create a situation where personal injury or death may occur. Should Buyer purchase or use SCILLC products for any such unintended or unauthorized application, Buyer shall indemnify and hold SCILLC and its officers, employees, subsidiaries, affiliates, and distributors harmless against all claims, costs, damages, and expenses, and reasonable attorney fees arising out of, directly or indirectly, any claim of personal injury or death associated with such unintended or unauthorized use, even if such claim alleges that SCILLC was negligent regarding the design or manufacture of the part. SCILLC is an Equal Opportunity/Affirmative Action Employer. This literature is subject to all applicable copyright laws and is not for resale in any manner.

PUBLICATION ORDERING INFORMATION

**LITERATURE FULFILLMENT:**  
Literature Distribution Center for ON Semiconductor  
P.O. Box 5163, Denver, Colorado 80217 USA  
Phone: 303-675-2175 or 800-344-3860 Toll Free USA/Canada  
Fax: 303-675-2176 or 800-344-3867 Toll Free USA/Canada  
Email: orderlit@onsemi.com

**N. American Technical Support:** 800-282-9855 Toll Free USA/Canada  
**Europe, Middle East and Africa Technical Support:**  
Phone: 421 33 790 2910  
**Japan Customer Focus Center**  
Phone: 81-3-5773-3850

**ON Semiconductor Website:** www.onsemi.com  
**Order Literature:** http://www.onsemi.com/orderlit

For additional information, please contact your local Sales Representative