

# HP NC550SFP Dual Port 10GbE Server Adapter User Guide



Part Number 599736-001  
February 2010 (First Edition)

© Copyright 2010 Hewlett-Packard Development Company, L.P.

The information contained herein is subject to change without notice. The only warranties for HP products and services are set forth in the express warranty statements accompanying such products and services. Nothing herein should be construed as constituting an additional warranty. HP shall not be liable for technical or editorial errors or omissions contained herein.

### **Intended audience**

This document is for the person who installs, administers, and troubleshoots servers and storage systems. HP assumes you are qualified in the servicing of computer equipment and trained in recognizing hazards in products with hazardous energy levels.

---

# Contents

Technician notes .....	4
Warnings, cautions, and notes .....	4
Downloading files .....	5
HP contact information.....	5
Introduction .....	6
Overview .....	6
LED indicators.....	6
Installing an adapter .....	8
Installation overview .....	8
Preventing electrostatic discharge .....	8
Installing an adapter in a server.....	9
Installing a low profile bracket.....	9
Connecting the network cable .....	10
Specifications.....	11
Cable specifications .....	11
General specifications .....	11
Compliance.....	11
Power and environmental specifications .....	12
Regulatory compliance notices .....	13
Regulatory compliance identification numbers .....	13
Federal Communications Commission notice.....	13
European Union regulatory notice.....	13
Canadian notice .....	14
Korean class A notice .....	14
Japanese class A notice .....	14
Disposal of waste equipment by users in private households in the European Union.....	14
Electrostatic discharge.....	15
Preventing electrostatic discharge .....	15
Grounding methods to prevent electrostatic discharge.....	15
Acronyms and abbreviations.....	16
Index.....	17

---

# Technician notes

## Warnings, cautions, and notes

---

 **WARNING:** Only authorized technicians trained by HP should attempt to repair this equipment. All troubleshooting and repair procedures are detailed to allow only subassembly/module-level repair. Because of the complexity of the individual boards and subassemblies, no one should attempt to make repairs at the component level or to make modifications to any printed wiring board. Improper repairs can create a safety hazard.

---

 **WARNING:** To reduce the risk of electric shock, personal injury, and damage to the equipment:

- Do not attempt to service any parts of the equipment other than those specified in the following procedure. Any other activities may require that you shut down the server and remove the power cord.
- Installation and maintenance of this product must be performed by individuals who are knowledgeable about the procedures, precautions and hazards associated with the product.

---

 **WARNING:** To reduce the risk of electric shock or damage to the equipment:

- Do not disable the power cord grounding plug. The grounding plug is an important safety feature.
- Plug the power cord into a grounded (earthed) electrical outlet that is easily accessible at all times.
- Unplug the power cord from the power supply to disconnect power to the equipment.
- Do not route the power cord where it can be walked on or pinched by items placed against it. Pay particular attention to the plug, electrical outlet, and the point where the cord extends from the server.

---



This symbol indicates the presence of a hot surface or hot component. If this surface is contacted, the potential for injury exists.

**WARNING:** To reduce the risk of injury from a hot component, allow the surface to cool before touching.

---

 **CAUTION:** To properly ventilate the system, you must provide at least 7.6 cm (3.0 in) of clearance at the front and back of the server.

---

 **CAUTION:** The server is designed to be electrically grounded (earthed). To ensure proper operation, plug the AC power cord into a properly grounded AC outlet only.

---

**NOTE:** Any indications of component replacement or printed wiring board modifications may void any warranty.

---

# Downloading files

1. Go to the HP website (<http://www.hp.com/#Support>).
2. Select **Download drivers and software (and firmware)**.
3. Type the adapter name in the **For product** box and then click **Go**. For example, type NC550SFP.
4. Download the drivers, firmware, or documentation as needed.

# HP contact information

For the name of the nearest HP authorized reseller:

- See the Contact HP worldwide (in English) webpage (<http://welcome.hp.com/country/us/en/wwcontact.html>).

For HP technical support:

- In the United States, for contact options see the Contact HP United States webpage ([http://welcome.hp.com/country/us/en/contact\\_us.html](http://welcome.hp.com/country/us/en/contact_us.html)). To contact HP by phone:
  - Call 1-800-HP-INVENT (1-800-474-6836). This service is available 24 hours a day, 7 days a week. For continuous quality improvement, calls may be recorded or monitored.
  - If you have purchased a Care Pack (service upgrade), call 1-800-633-3600. For more information about Care Packs, refer to the HP website (<http://www.hp.com/hps>).
- In other locations, see the Contact HP worldwide (in English) webpage (<http://welcome.hp.com/country/us/en/wwcontact.html>).

# Introduction

## Overview

The HP NC550SFP Dual Port 10GbE Server Adapter is a dual port PCI Express (PCIe) 10 Gigabit ProLiant Ethernet adapter. The network connection is made through two 10Gbps Ethernet SFP+ ports.

In addition to standard HP network server adapter features, the NC550SFP is capable of supporting teaming for load balancing and failover, TCP checksum and segmentation (LSO) offload capability, VLAN tagging, jumbo frames, IPv6, and other features. The NC550SFP can be installed in either standard or low profile slots.

## LED indicators

The NC550SFP adapter has two ports with LED indicators for Link (L) and Activity (A) for each port. Standard-height bracket is shown below with the SFP+ ports and LED indicators.

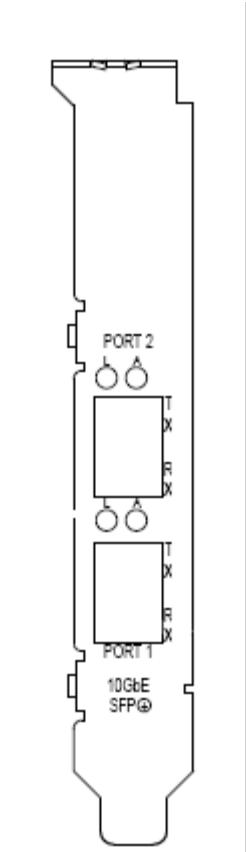

The NC550SFP 10 Gigabit Server Adapter LED indicators operate as described in the following table.

<b>LED indicator</b>	<b>Status</b>	<b>Description</b>
<b>Act.</b>	Off	Indicates no network activity on the link.
	Flashing (Green)	Indicates network activity on the link. The adapter is sending or receiving network data at up to 10Gbps.
<b>Link</b>	Off	No link to the adapter is established. The adapter is not receiving power or the cable connection is faulty.
	On (Yellow)	Link to the adapter is established. The adapter is receiving power and the cable connection is good.

---

# Installing an adapter

## Installation overview

This section describes installation precautions, how to install the adapter, and how to connect the network cable.



**WARNING:** To reduce the risk of personal injury or damage to the equipment, consult the safety information and user documentation provided with the server before attempting the installation.

Many servers are capable of providing energy levels that are considered hazardous and are intended to be serviced only by qualified personnel who have been trained to deal with these hazards. Do not remove enclosures or attempt to bypass any interlocks that may be provided for the purpose of removing these hazardous conditions.



**WARNING:** Installation of this adapter should be performed by individuals who are both qualified in the servicing of computer equipment, and trained in the hazards associated with products capable of producing hazardous energy levels.

This adapter is intended to be installed in Certified (UL or CSA) ITE equipment having instructions for adding and removing user installed components such as PCI, PCI-X, and PCI Express devices. Refer to the equipment instructions to verify that it is suitable for user installed components and that it has the power capacity to support all of the installed components.

---

**NOTE:** Before removing the cover of your server, refer to the HP documentation for the proper methods for installing a PCI Express card and avoiding electric shock hazards.

---

## Preventing electrostatic discharge

To prevent damaging the system, be aware of the precautions you need to follow when setting up the system or handling parts. A discharge of static electricity from a finger or other conductor may damage system boards or other static-sensitive devices. This type of damage may reduce the life expectancy of the device.

To prevent electrostatic damage:

- Avoid hand contact by transporting and storing products in static-safe containers.
- Keep electrostatic-sensitive parts in their containers until they arrive at static-free workstations.
- Place parts on a grounded surface before removing them from their containers.
- Avoid touching pins, leads, or circuitry.
- Always be properly grounded when touching a static-sensitive component or assembly.



# Installing an adapter in a server

See the HP ProLiant server documentation for additional information on how to safely install a PCI Express card in the server.

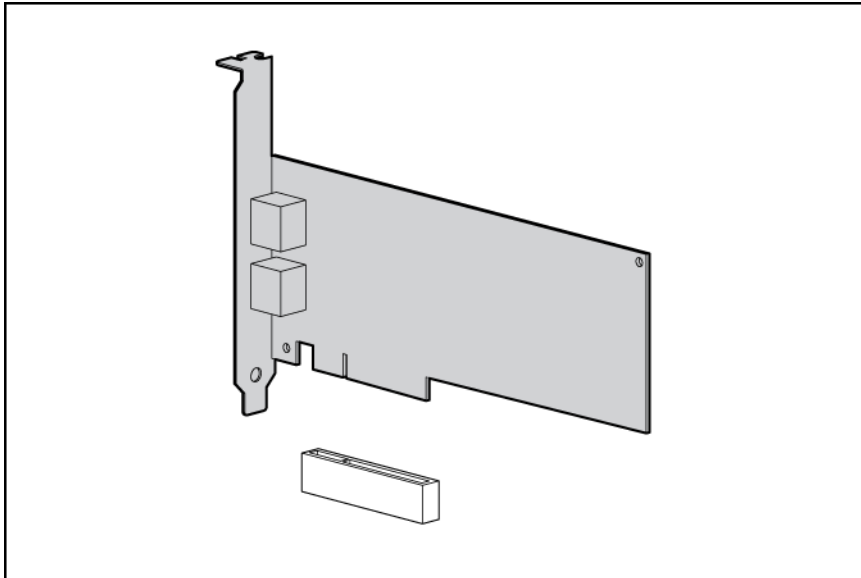

**⚠ CAUTION:** If the server is not PCI Hot Plug compliant, power it down and unplug the power cord from the power outlet before removing the server access panel. Failure to do so may damage the adapter or server.

1. Power down the server.
2. Remove the power cord and server access panel.

**⚠ WARNING:** To reduce the risk of personal injury from a hot component, allow the surface of the option card to cool before touching it.

**⚠ WARNING:** To reduce the risk of personal injury from hot surfaces, allow the drives and the internal system components to cool before touching them.

3. Identify the PCI Express option slot in which the adapter is to be installed. If a low profile option slot is to be used, install the low profile bracket onto the adapter.
4. Remove the cover bracket from the PCI Express slot.
5. Firmly seat the adapter in the PCI Express slot and secure the adapter bracket.

**NOTE:** For 1U type servers you may need to replace the standard profile bracket with a low profile bracket. See [Installing a low profile bracket](#).

6. Replace the access panel and plug in the power cord.

## Installing a low profile bracket

You may have to install a low profile bracket prior to the product installation. The low profile bracket replaces the existing standard profile bracket shipped on the product.

1. Using a correctly sized Phillips head screwdriver, carefully remove the two board lock screws located above and below the SFP+ connectors.
2. Remove the standard profile bracket and place the low profile bracket over the connectors. Be careful not to damage the connectors or bend the low profile bracket.
3. Reinstall the two Phillips screws.

## Connecting the network cable

The NC550SFP has two SFP+ ports. These ports support either of the following:

- Direct Attached Copper (DAC) cables
- Optical Modules to be used with fiber optic cables

See Cable specifications (on page 11) for the maximum cable length supported.

To connect the NC550SFP to the network, complete the following steps:

1. Orient the SFP+ optical module or DAC cable so that the Gold Fingers on the edge of the circuit board is located closest to the option card circuit board.
2. Install the SFP+ optical module or DAC cable all the way into the SFP+ socket until it clicks into place and is securely latched.
3. If an optical module is used, remove the protective cover and connect the fiber optic cable.

# Specifications

## Cable specifications

SFP+ module type	Cable Connector Type	Wavelength (nm), type of cable	Core Size (microns, $\mu\text{m}$ )	Cable grade	Minimum modal bandwidth (MHz-km)	Maximum Cable Length (meters)
10GBASE-SR (short range) Optical Module	LC	850, Multi-Mode Fiber (MMF)	62.5	("FDDI")	160	26
			62.5	OM1	200	33
			50		400	66
			50	OM2	500	82
			50	OM3	2000	300
10GBASE-CR with Direct Attached Copper (DAC) cable	SFP+	N/A, Twin Axial Copper	24 to 28 AWG, depending on length and manufacturer	N/A	N/A	7

## General specifications

General specifications	Value
Controller	ServerEngines BE4210 (BladeEngine2)
Data rate	10Gbps, full-duplex
PCI bus	8 Lane (x8) PCI Express Gen 2, compatible with x4 and x8 bus widths
Connectors	2 SFP+
Dimensions (LxW)	6.6 x 2.7 inches (16.765 cm x 6.89 cm) without bracket

## Compliance

Compliance	Standard
IEEE	IEEE802.3x, IEEE802.3ad, IEEE802.1p, IEEE802.1q, IEEE802.3az, IEEE802.3ae, IEEE802.3ap, IEEE802.1qau
Safety	UL Mark (US and Canada) EN 60950

<b>Compliance</b>	<b>Standard</b>
Other	PCIe v2.0 RoHS 6 of 6 IPv4, IPv6 CE Microsoft WHQL (Windows Hardware Quality Labs) Server Design Guide version 3.0 (SDG 3.0) SFF-8431- 10 Gigabit Small Form Factor Pluggable Module "SFP+" SNMP IPv4/IPv6 TCP, UDP checksum Offload IPv4/IPv6 TCP, Large Send Offload IPv4/IPv6 TCP, Large Receive Offload Receive-Side Scaling Jumbo Frames up to 9000 Bytes

## Power and environmental specifications

<b>Power and environmental specifications</b>	<b>Value</b>
Operating	Temperature 0° to 55° C (32° to 131° F) Humidity 10 to 90% relative humidity, non-condensing.
Non-operating	Temperature -40 to 70 °C (-40 to 158 °F) Humidity 5 to 95% relative humidity, non-condensing.
Power	15 Watts typical, 18 Watts maximum

---

# Regulatory compliance notices

## Regulatory compliance identification numbers

For the purpose of regulatory compliance certifications and identification, this product has been assigned a unique regulatory model number. The regulatory model number can be found on the product nameplate label, along with all required approval markings and information. When requesting compliance information for this product, always refer to this regulatory model number. The regulatory model number is not the marketing name or model number of the product.

## Federal Communications Commission notice

This equipment has been tested and found to comply with the limits for a Class A digital device, pursuant to Part 15 of the FCC Rules. These limits are designed to provide reasonable protection against harmful interference when the equipment is operated in a commercial environment. This equipment generates, uses, and can radiate radio frequency energy and, if not installed and used in accordance with the instructions, may cause harmful interference to radio communications. Operation of this equipment in a residential area is likely to cause harmful interference, in which case the user will be required to correct the interference at personal expense.

## European Union regulatory notice

This product complies with the following EU Directives:

- Low Voltage Directive 2006/95/EC
- EMC Directive 2004/108/EC

Compliance with these directives implies conformity to applicable harmonized European standards (European Norms) which are listed on the EU Declaration of Conformity issued by Hewlett-Packard for this product or product family.

This compliance is indicated by the following conformity marking placed on the product:



This marking is valid for non-Telecom products and EU harmonized Telecom products (e.g. Bluetooth).



This marking is valid for EU non-harmonized Telecom products.

\*Notified body number (used only if applicable—refer to the product label)

Hewlett-Packard GmbH, HQ-TRE, Herrenberger Strasse 140, 71034 Boeblingen, Germany

The official EU CE declaration of conformity for this device can be found on the HP website (<http://www.hp.com/go/certificates>).

## Canadian notice

This Class A digital apparatus meets all requirements of the Canadian Interference-Causing Equipment Regulations.

Cet appareil numérique de la classe A respecte toutes les exigences du Règlement sur le matériel brouilleur du Canada.

## Korean class A notice

A급 기기 (업무용 방송통신기기)	이 기기는 업무용(A급)으로 전자파적합등록을 한 기기이오니 판매자 또는 사용자는 이 점을 주의하시기 바라며, 가정 외의 지역에서 사용하는 것을 목적으로 합니다.
-----------------------	---

## Japanese class A notice

この装置は、クラスA情報技術装置です。この装置を家庭環境で使用すると電波妨害を引き起こすことがあります。この場合には使用者が適切な対策を講ずるよう要求されることがあります。	VCCI-A
--	--------

## Disposal of waste equipment by users in private households in the European Union



This symbol on the product or on its packaging indicates that this product must not be disposed of with your other household waste. Instead, it is your responsibility to dispose of your waste equipment by handing it over to a designated collection point for the recycling of waste electrical and electronic equipment. The separate collection and recycling of your waste equipment at the time of disposal will help to conserve natural resources and ensure that it is recycled in a manner that protects human health and the environment. For more information about where you can drop off your waste equipment for recycling, please contact your local city office, your household waste disposal service or the shop where you purchased the product.

---

# Electrostatic discharge

## Preventing electrostatic discharge

To prevent damaging the system, be aware of the precautions you need to follow when setting up the system or handling parts. A discharge of static electricity from a finger or other conductor may damage system boards or other static-sensitive devices. This type of damage may reduce the life expectancy of the device.

To prevent electrostatic damage:

- Avoid hand contact by transporting and storing products in static-safe containers.
- Keep electrostatic-sensitive parts in their containers until they arrive at static-free workstations.
- Place parts on a grounded surface before removing them from their containers.
- Avoid touching pins, leads, or circuitry.
- Always be properly grounded when touching a static-sensitive component or assembly.

## Grounding methods to prevent electrostatic discharge

Several methods are used for grounding. Use one or more of the following methods when handling or installing electrostatic-sensitive parts:

- Use a wrist strap connected by a ground cord to a grounded workstation or computer chassis. Wrist straps are flexible straps with a minimum of 1 megohm  $\pm 10$  percent resistance in the ground cords. To provide proper ground, wear the strap snug against the skin.
- Use heel straps, toe straps, or boot straps at standing workstations. Wear the straps on both feet when standing on conductive floors or dissipating floor mats.
- Use conductive field service tools.
- Use a portable field service kit with a folding static-dissipating work mat.

If you do not have any of the suggested equipment for proper grounding, have an authorized reseller install the part.

For more information on static electricity or assistance with product installation, contact an authorized reseller.

---

# Acronyms and abbreviations

## CSA

Canadian Standards Association

## DMA

direct memory access

## IEEE

Institute of Electrical and Electronics Engineers

## iSCSI

Internet Small Computer System Interface

## PCI Express

Peripheral Component Interconnect Express

## SFP

small form-factor pluggable



---

# Index

## A

adapter LEDs 6  
adapters 6

## B

bracket, low profile 9

## C

cables, networking 10  
compliance 11, 12, 13  
contact information 5

## D

disposal, waste 14  
downloading files 5

## E

electrostatic discharge 8, 15  
environmental specifications 12

## G

grounding methods 15

## L

LC connector 10  
LEDs 6  
low profile bracket 9

## P

PCI (peripheral component interface) 8  
power specifications 12

## R

regulatory compliance notices 13, 14

## S

specifications 11, 12  
standards 13

## T

technical notes 4

## V

ventilation 4

## W

warnings 4