

NC7SZ373 TinyLogic® UHS D-Type Latch with 3-STATE Output

General Description

The NC7SZ373 is a single positive edge-triggered D-type CMOS Latch with 3-STATE output from Fairchild's Ultra High Speed Series of TinyLogic® in the space saving SC70 6-lead package. The device is fabricated with advanced CMOS technology to achieve ultra high speed with high output drive while maintaining low static power dissipation over a very broad V_{CC} operating range. The device is specified to operate over the 1.65V to 5.5V range. The inputs and output are high impedance when V_{CC} is 0V. Inputs tolerate voltages up to 7V independent of V_{CC} operating voltage. The latch appears transparent to the data when Latch Enable (LE) is HIGH. When LE is LOW, the data that meets the setup time is latched. The output tolerates voltages above V_{CC} in the 3-STATE condition.

Features

- Space saving SC70 6-lead package
- Ultra small MicroPak™ leadless package
- Ultra High Speed; t_{PD} 2.6 ns Typ into 50 pF at 5V V_{CC}
- High Output Drive; ± 24 mA at 3V V_{CC}
- Broad V_{CC} Operating Range; 1.65V to 5.5V
- Matches the performance of LCX when operated at 3.3V V_{CC}
- Power down high impedance inputs/output
- Overvoltage tolerant inputs facilitate 5V to 3V translation
- Patented noise/EMI reduction circuitry implemented

Ordering Code:

Order Number	Package Number	Product Code Top Mark	Package Description	Supplied As
NC7SZ373P6X	MAA06A	Z73	6-Lead SC70, EIAJ SC88, 1.25mm Wide	3k Units on Tape and Reel
NC7SZ373L6X	MAC06A	D4	6-Lead MicroPak, 1.0mm Wide	5k Units on Tape and Reel

TinyLogic® is a registered trademark of Fairchild Semiconductor Corporation.
MicroPak™ is a trademark of Fairchild Semiconductor Corporation.

NC7SZ373 TinyLogic® UHS D-Type Latch with 3-STATE Output

Logic Symbol

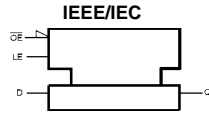

Pin Descriptions

Pin Names	Description
D	Data Input
LE	Latch Enable Input
\overline{OE}	Output Enable Input
Q	Latch Output

Function Table

Inputs			Output
LE	D	\overline{OE}	Q
H	L	L	L
H	H	L	H
L	X	L	Q_{n-1}
X	X	H	Z

H = HIGH Logic Level X = Immaterial
 L = LOW Logic Level Z = HIGH Impedance
 Q_{n-1} = Previous state prior to HIGH-to-LOW transition of latch enable

Connection Diagrams

Pin Assignments for SC70

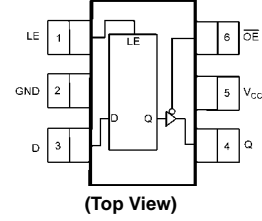

Pin One Orientation Diagram

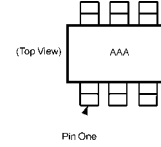

AAA = Product Code Top Mark - see ordering code
Note: Orientation of Top Mark determines Pin One location. Read the top product code mark left to right, Pin One is the lower left pin.(see diagram).

Pad Assignments for MicroPak

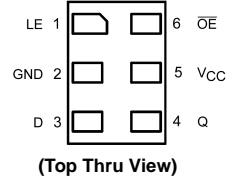

Absolute Maximum Ratings (Note 1)			Recommended Operating Conditions (Note 2)		
Supply Voltage (V_{CC})	-0.5V to +7.0V		Power Supply	Operating (V_{CC})	1.65V to 5.5V
DC Input Voltage (V_{IN})	-0.5V to +7.0V		Data Retention		1.5V to 5.5V
DC Output Voltage (V_{OUT})	-0.5V to +7.0V		Input Voltage (V_{IN})		0V to 5.5V
DC Input Diode Current (I_{IK})			Output Voltage (V_{OUT})	Active State	0V to V_{CC}
$V_{IN} < 0V$	-50 mA		3-STATE		0V to 5.5V
DC Output Diode Current (I_{OK})			Input Rise and Fall Time (t_r, t_f)	$V_{CC} = 1.8V, 2.5V \pm 0.2V$	0 to 20 ns/V
$V_{OUT} < 0V$	-50 mA			$V_{CC} = 3.3V \pm 0.3V$	0 to 10 ns/V
DC Output (I_{OUT}) Source/Sink Current	± 50 mA			$V_{CC} = 5.5V \pm 0.5V$	0 to 5 ns/V
DC V_{CC}/GND Current (I_{CC}/I_{GND})	± 50 mA		Operating Temperature (T_A)		-40°C to +85°C
Storage Temperature Range (T_{STG})	-65°C to +150°C		Thermal Resistance (θ_{JA})		350° C/W
Junction Temperature under Bias (T_J)	150°C				
Junction Lead Temperature (T_L)					
(Soldering, 10 seconds)	260°C				
Power Dissipation (P_D) @+85°C	180 mW				

Note 1: The "Absolute Maximum Ratings": are those values beyond which the safety of the device cannot be guaranteed. The device should not be operated at these limits. The parametric values defined in the Electrical Characteristics tables are not guaranteed at the absolute maximum ratings. The "Recommended Operating Conditions" table will define the conditions for actual device operation.

Note 2: Unused inputs must be held HIGH or LOW. They may not float.

DC Electrical Characteristics

Symbol	Parameter	V_{CC} (V)	$T_A = +25^\circ C$			$T_A = -40^\circ C$ to $+85^\circ C$		Unit	Conditions	
			Min	Typ	Max	Min	Max			
V_{IH}	HIGH Level Control	1.65 to 1.95	0.75 V_{CC}			0.75 V_{CC}		V		
	Input Voltage	2.3 to 5.5	0.7 V_{CC}			0.7 V_{CC}				
V_{IL}	LOW Level Control	1.65 to 1.95	0.25 V_{CC}			0.25 V_{CC}		V		
	Input Voltage	2.3 to 5.5	0.3 V_{CC}			0.3 V_{CC}				
V_{OH}	HIGH Level Control	1.65	1.55	1.65	1.55		V	$V_{IN} = V_{IH}$	$I_{OH} = -100 \mu A$	
		1.8	1.7	1.8	1.7					
		2.3	2.2	2.3	2.2					
		3.0	2.9	3.0	2.9					
		4.5	4.4	4.5	4.4					
	Output Voltage	1.65	1.24	1.52	1.29			$I_{OH} = -4$ mA $I_{OH} = -8$ mA $I_{OH} = -16$ mA $I_{OH} = -24$ mA $I_{OH} = -32$ mA		
		2.3	1.9	2.15	1.9					
		3.0	2.4	2.8	2.4					
		3.0	2.3	2.68	2.3					
		4.5	3.8	4.2	3.8					
V_{OL}	LOW Level Control	1.65	0.0			0.0		V	$V_{IN} = V_{IL}$	$I_{OL} = 100 \mu A$
		1.8	0.0			0.1				
		2.3	0.0			0.1				
		3.0	0.0			0.1				
		4.5	0.0			0.1				
	Output Voltage	1.65	0.08			0.24			$I_{OL} = 4$ mA $I_{OL} = 8$ mA $I_{OL} = 16$ mA $I_{OL} = 24$ mA $I_{OL} = 32$ mA	
		2.3	0.10			0.3				
		3.0	0.15			0.4				
		3.0	0.22			0.55				
		4.5	0.22			0.55				
I_{IN}	Input Leakage Current	0 to 5.5	± 0.1			± 1.0		μA	$0 \leq V_{IN} \leq 5.5V$	
I_{OZ}	3-STATE Output Leakage	1.65 to 5.5	± 0.5			± 5.0		μA	$V_{IN} = V_{IL}$ or V_{IH} $0 \leq V_{OUT} \leq 5.5V$	
I_{OFF}	Power-Off Leakage Current	0.0	1.0			10		μA	V_{IN} or $V_{OUT} = 5.5V$	
I_{CC}	Quiescent Supply Current	1.65 to 5.5	1.0			10		μA	$V_{IN} = 5.5V, GND$	

AC Electrical Characteristics										
Symbol	Parameter	V _{CC} (V)	T _A = +25°C			T _A = -40°C to +85°C		Units	Conditions	Figure Number
			Min	Typ	Max	Min	Max			
t _{PLH} t _{PHL}	Propagation Delay D to Q	1.65	2.0	9.0	15.0	2.0	16.0	ns	C _L = 15 pF R _D = 1 MΩ S ₁ = Open	Figures 1, 3
		1.8	2.0	6.1	10.0	2.0	10.5			
		2.5 ± 0.2	1.5	3.6	6.5	1.6	6.8			
		3.3 ± 0.3	1.0	2.7	4.6	1.2	5.0			
		5.0 ± 0.5	1.0	2.0	3.4	1.0	3.7			
		3.3 ± 0.3	1.5	3.3	5.5	1.5	6.2			
		5.0 ± 0.5	1.0	2.6	4.3	1.3	4.8		C _L = 50 pF R _D = 500Ω, S ₁ = Open	Figures 1, 3
t _{PLH} t _{PHL}	Propagation Delay LE to Q	1.65	2.0	9.0	1.45	2.0	15.0	ns	C _L = 15 pF R _D = 1 MΩ S ₁ = Open	Figures 1, 3
		1.8	2.0	6.0	9.6	2.0	10.0			
		2.5 ± 0.2	1.8	3.5	6.1	1.5	6.6			
		3.3 ± 0.3	1.3	2.6	4.4	1.0	4.8			
		5.0 ± 0.5	1.0	2.0	3.2	0.8	3.5			
		3.3 ± 0.3	1.5	3.3	5.3	1.5	6.2			
		5.0 ± 0.5	1.3	2.6	4.2	1.2	4.6		C _L = 50 pF R _D = 500Ω, S ₁ = Open	Figures 1, 4
t _{PZL} t _{PZH}	Output Enable Time	1.65	2.0	9.0	13.5	2.0	14.6	ns	C _L = 50 pF, V _I = 2x V _{CC} R _U , R _D = 500Ω S ₁ = GND for t _{PZH} S ₁ = V _I for t _{PZL}	Figures 1, 4
		1.8	2.0	6.0	9.0	2.0	9.5			
		2.5 ± 0.2	2.0	3.7	6.0	1.8	6.6			
		3.3 ± 0.3	1.5	2.8	5.0	1.4	5.3			
		5.0 ± 0.5	1.0	2.2	3.7	1.0	3.9			
t _{PLZ} t _{PHZ}	Output Disable Time	1.65	2.0	7.7	12.0	2.0	13.0	ns	C _L = 50 pF, V _I = 2x V _{CC} R _U , R _D = 500Ω S ₁ = GND for t _{PHZ} S ₁ = V _I for t _{PLZ}	Figures 1, 4
		1.8	2.0	5.1	8.0	2.0	8.5			
		2.5 ± 0.2	2.0	3.5	6.0	1.8	6.3			
		3.3 ± 0.3	1.5	2.8	4.5	1.4	4.7			
		5.0 ± 0.5	1.0	2.3	3.7	1.0	3.9			
t _S	Setup Time, D to LE	2.5 ± 0.2				2.0		ns	C _L = 50 pF R _D = 500 Ω, S ₁ = Open	Figures 1, 5
		3.3 ± 0.3				1.5				
		5.0 ± 0.5				1.5				
t _H	Hold Time, D to LE	2.5 ± 0.2				1.5		ns	C _L = 50 pF R _D = 500 Ω, S ₁ = Open	Figures 1, 5
		3.3 ± 0.3				1.5				
		5.0 ± 0.5				1.5				
t _W	Pulse Width, LE	2.5 ± 0.2				3.0		ns	C _L = 50 pF R _D = 500 Ω, S ₁ = Open	Figures 1, 5
		3.3 ± 0.3				3.0				
		5.0 ± 0.5				3.0				

Capacitance (Note 3)

Symbol	Parameter	Typ	Max	Units	Conditions
C _{IN}	Input Capacitance	3		pF	V _{CC} = Open, V _{IN} = 0V or V _{CC}
C _{OUT}	Output Capacitance	4		pF	V _{CC} = 3.3V, V _{IN} = 0V or V _{CC}
C _{PD}	Power Dissipation Capacitance (Note 4)	14 17		pF	V _{CC} = 3.3V V _{CC} = 5.0V

Note 3: T_A = +25C, f = 1 MHz.

Note 4: C_{PD} is defined as the value of the internal equivalent capacitance which is derived from dynamic operating current consumption (I_{CCD}) at no output loading and operating at 50% duty cycle. (See Figure 2) C_{PD} is related to I_{CCD} dynamic operating current by the expression:
I_{CCD} = (C_{PD})(V_{CC})(f_{IN}) + (I_{CC}Static).

AC Loading and Waveforms

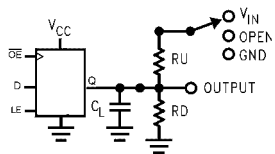

C_L includes load and stray capacitance
 Input PRR = 1.0 MHz, $t_w = 500$ ns

FIGURE 1. AC Test Circuit

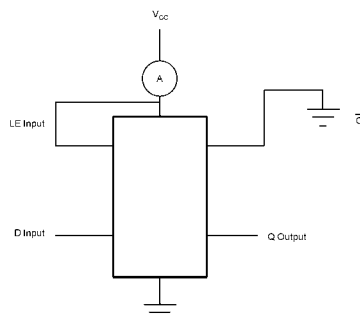

D Input = AC Waveform; $t_r = t_f = 1.8$ ns;
 D Input PRR = 10 MHz; Duty Cycle = 50%

FIGURE 2. I_{CCD} Test Circuit

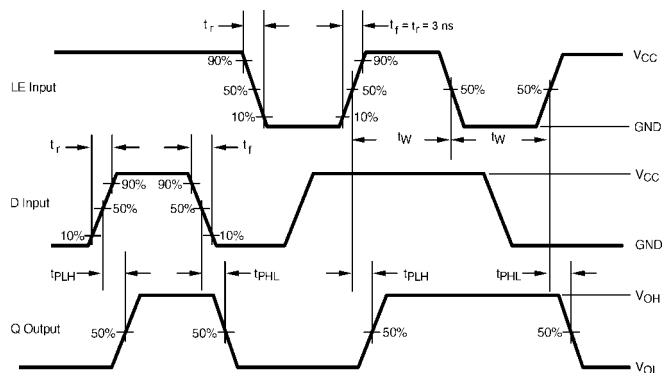

FIGURE 3. AC Waveforms

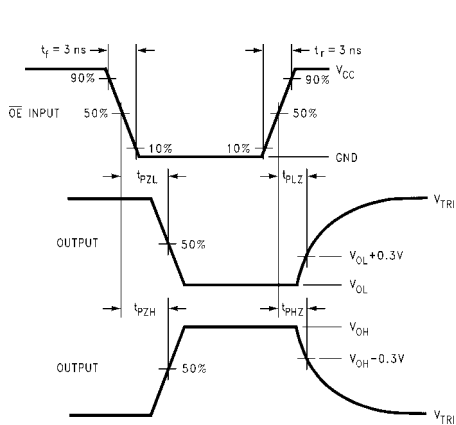

FIGURE 4. AC Waveforms

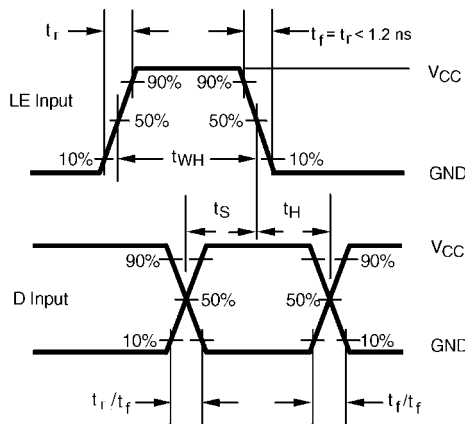

FIGURE 5. AC Waveforms

Tape and Reel Specification

TAPE FORMAT for SC70

Package Designator	Tape Section	Number Cavities	Cavity Status	Cover Tape Status
P6X	Leader (Start End)	125 (typ)	Empty	Sealed
	Carrier	3000	Filled	Sealed
	Trailer (Hub End)	75 (typ)	Empty	Sealed

TAPE DIMENSIONS inches (millimeters)

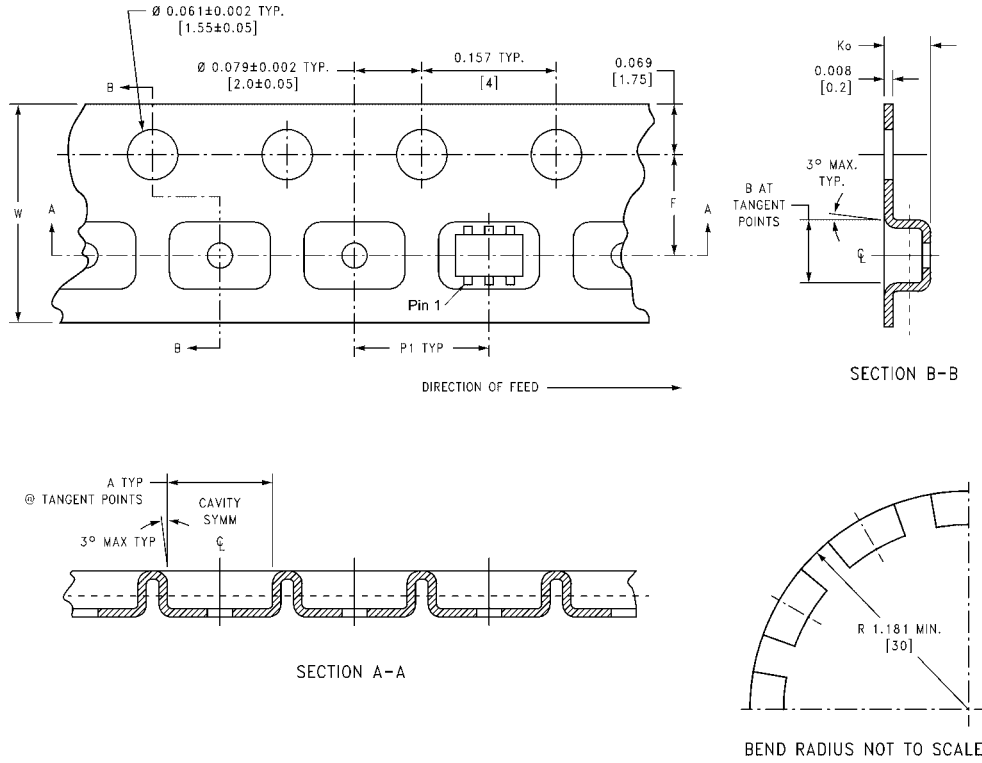

Package	Tape Size	DIM A	DIM B	DIM F	DIM K ₀	DIM P1	DIM W
SC70-6	8 mm	0.093 (2.35)	0.096 (2.45)	0.138 ± 0.004 (3.5 ± 0.10)	0.053 ± 0.004 (1.35 ± 0.10)	0.157 (4)	0.315 ± 0.004 (8 ± 0.1)

Tape and Reel Specification (Continued)

TAPE FORMAT for MicroPak

Package Designator	Tape Section	Number Cavities	Cavity Status	Cover Tape Status
L6X	Leader (Start End)	125 (typ)	Empty	Sealed
	Carrier	3000	Filled	Sealed
	Trailer (Hub End)	75 (typ)	Empty	Sealed

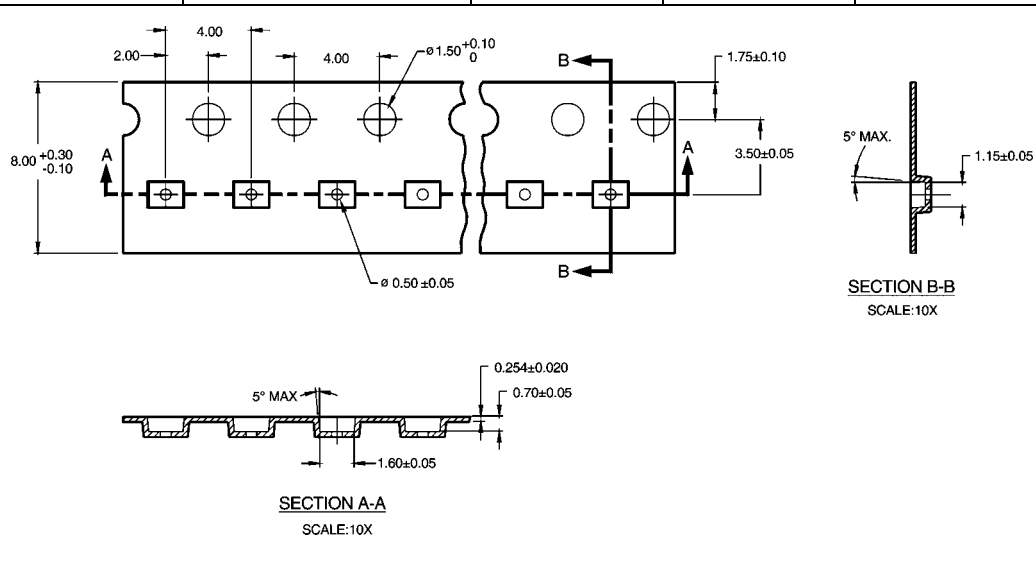

REEL DIMENSIONS inches (millimeters)

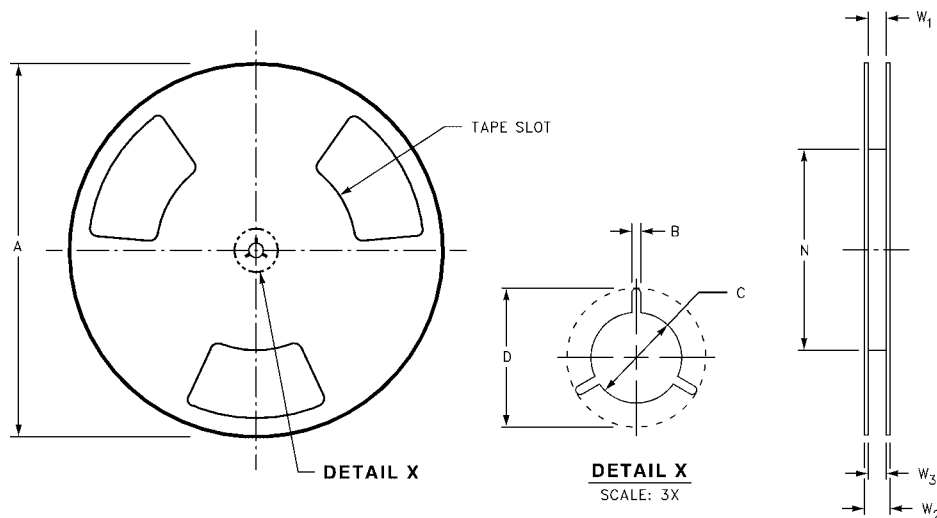

Tape Size	A	B	C	D	N	W1	W2	W3
8 mm	7.0 (177.8)	0.059 (1.50)	0.512 (13.00)	0.795 (20.20)	2.165 (55.00)	0.331 + 0.059/-0.000 (8.40 + 1.50/-0.00)	0.567 (14.40)	W1 + 0.078/-0.039 (W1 + 2.00/-1.00)

NC7SZ373

Physical Dimensions inches (millimeters) unless otherwise noted

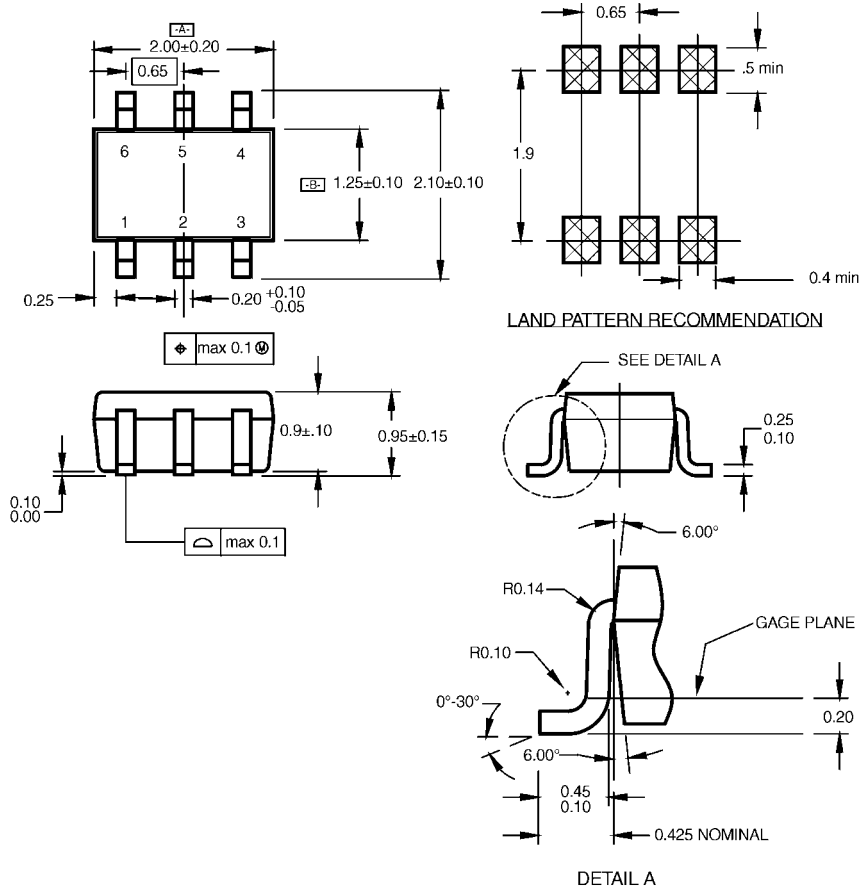

NOTES:

- A. CONFORMS TO EIAJ REGISTERED OUTLINE DRAWING SC88.
- B. DIMENSIONS DO NOT INCLUDE BURRS OR MOLD FLASH.
- C. DIMENSIONS ARE IN MILLIMETERS.

MAA06ARevC

**6-Lead SC70, EIAJ SC88, 1.25mm Wide
Package Number MAA06A**

Physical Dimensions inches (millimeters) unless otherwise noted (Continued)

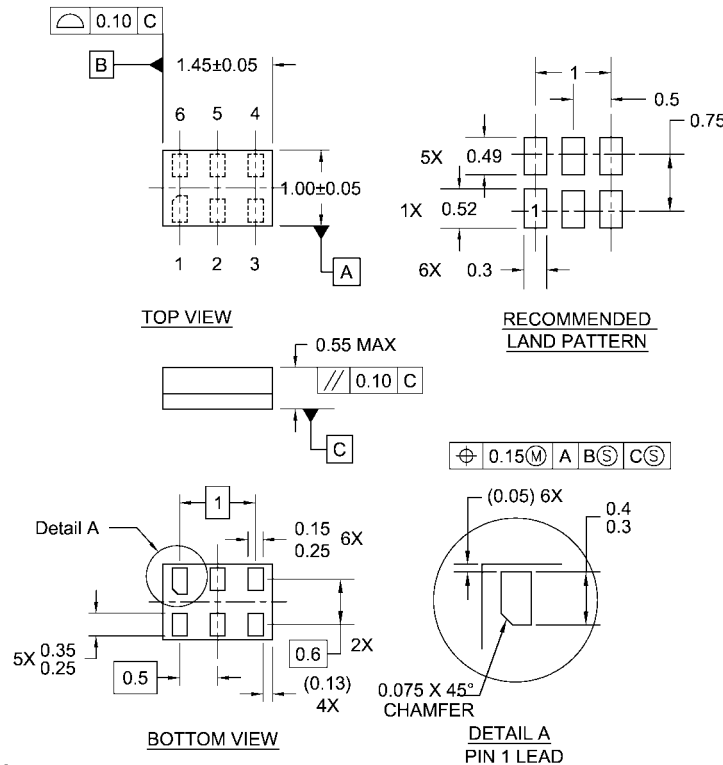

- Notes:
1. JEDEC PACKAGE REGISTRATION IS ANTICIPATED
 2. DIMENSIONS ARE IN MILLIMETERS
 3. DRAWING CONFORMS TO ASME Y14.5M-1994

MAC06ARevB

**6-Lead MicroPak, 1.0mm Wide
Package Number MAC06A**

Fairchild does not assume any responsibility for use of any circuitry described, no circuit patent licenses are implied and Fairchild reserves the right at any time without notice to change said circuitry and specifications.

LIFE SUPPORT POLICY

FAIRCHILD'S PRODUCTS ARE NOT AUTHORIZED FOR USE AS CRITICAL COMPONENTS IN LIFE SUPPORT DEVICES OR SYSTEMS WITHOUT THE EXPRESS WRITTEN APPROVAL OF THE PRESIDENT OF FAIRCHILD SEMICONDUCTOR CORPORATION. As used herein:

1. Life support devices or systems are devices or systems which, (a) are intended for surgical implant into the body, or (b) support or sustain life, and (c) whose failure to perform when properly used in accordance with instructions for use provided in the labeling, can be reasonably expected to result in a significant injury to the user.
2. A critical component in any component of a life support device or system whose failure to perform can be reasonably expected to cause the failure of the life support device or system, or to affect its safety or effectiveness.

www.fairchildsemi.com