

For LCD/PDP Monitor (PC, DVI, Video) Interface Controller
For 1280x768, 1366x768, 1600x1200, 1920x1080, 1920x1200 Resolutions TFT LCD/PDP

DATA SHEET

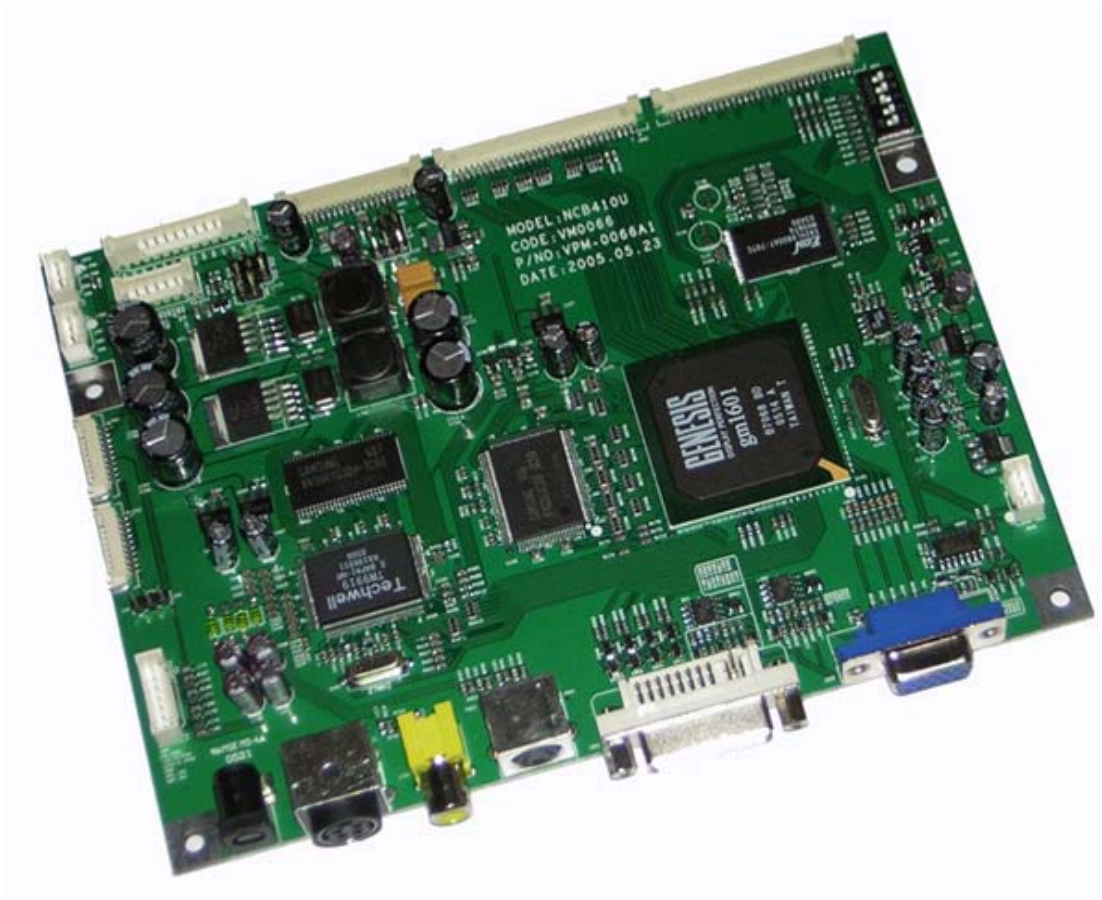

TFT LCD Monitor Control Board

NCB410U4-DS-A1

June 2005

CONTENT

• INTRODUCTION	-----	4
• GENERAL SPECIFICATION	-----	5
• SYSTEM DESIGN	-----	8
• BLOCK DIAGRAM	-----	9
• ASSEMBLY NOTES	-----	10
• CONNECTION & OPERATION	-----	13
• OSD	-----	14
• OSD FUNCTION	-----	16
• CONNECTOR, PINOUT & JUMPER	-----	21
• CONTROLLER DIMENSIONS	-----	28
• APPLICATION NOTES	-----	29
• TROUBLESHOOTING	-----	30
• APPLICABLE GRAPHIC MODE	-----	31
• ACCESSORY	-----	32
• APPENDIX	-----	33

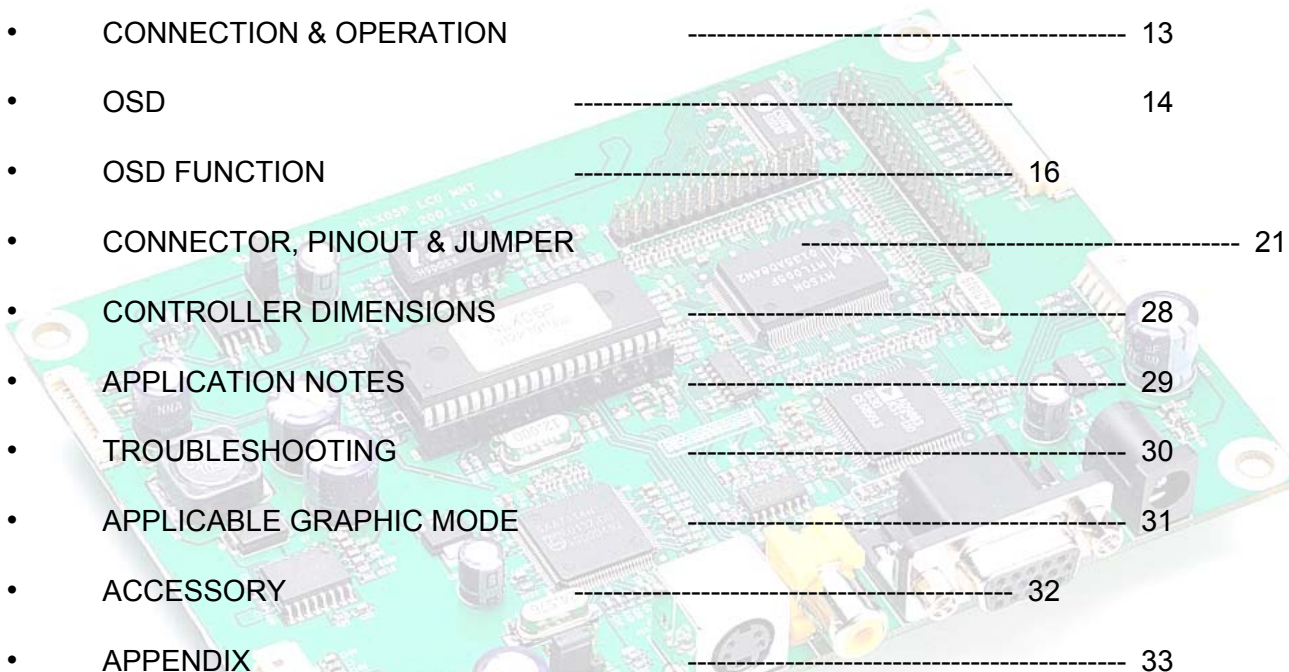

Revision History

No	Data	Revision	Page
1	Preliminary Release	A1	
2			

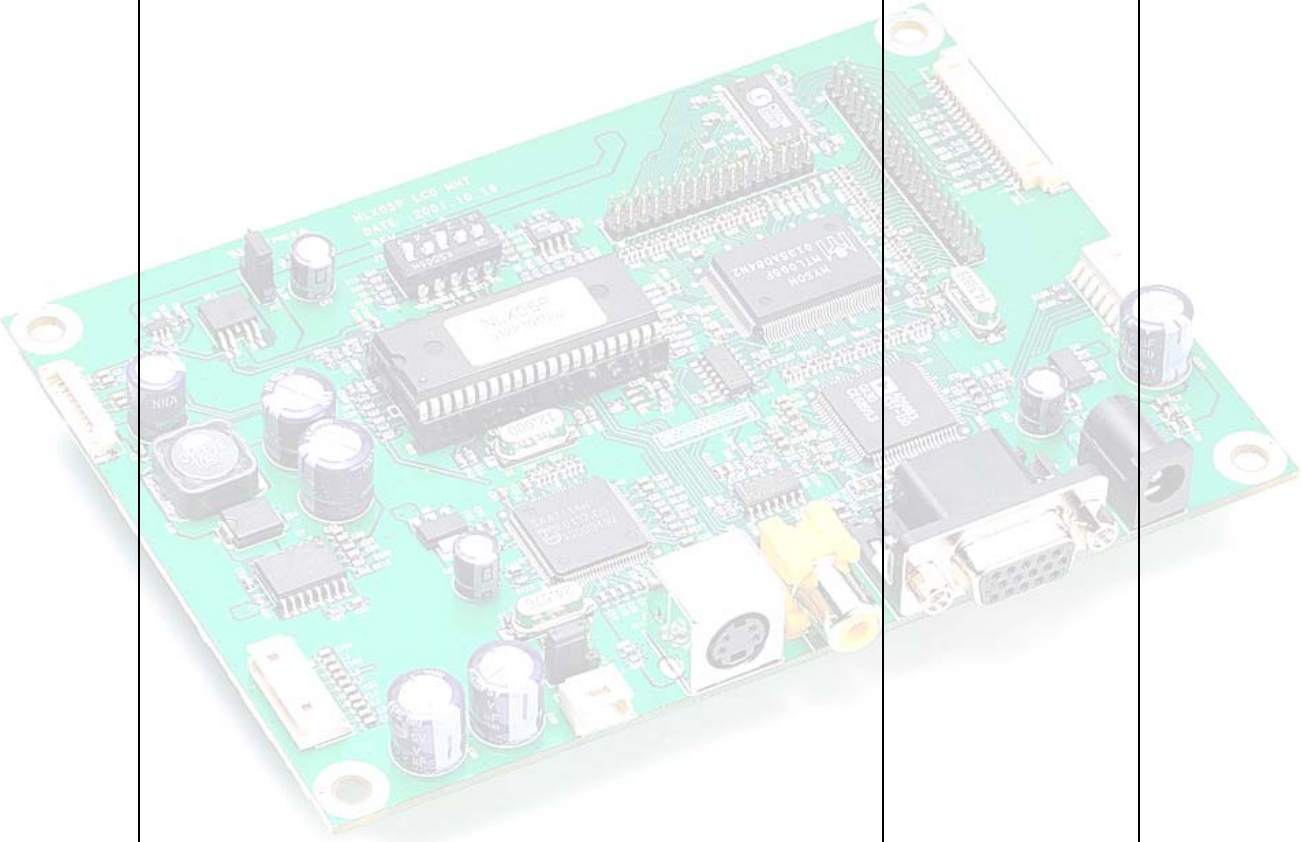

INTRODUCTION

Designed for LCD monitor and other flat panel display application the NCB410U4 controller provides an auto-input synchronization and easy to use interface controller for:

- ▶ TFT (active matrix) LCD panels of 1280x768, 1366x768, 1600x1200, 1920x1080 and 1920x1200 resolutions.
- ▶ PDP panels of 852x480, 1024x768 and 1366x768 resolutions.
- ▶ Computer video signals of VGA, SVGA, XGA, WXGA, SXGA and UXGA standard.
- ▶ Video signals of NTSC, PAL standard
- ▶ Input Signal Support
 - All VESA standard

HOW TO PROCEED

- ▶ Ensure that you have all parts & they are correct, refer to:
 - Connection diagram
 - Connector reference
 - Assembly notes
- ▶ Check controller switch & jumper settings (errors may damage the panel)
- ▶ Prepare the PC & Video
- ▶ Connect the parts
- ▶ Understand the operation & functions

IMPORTANT USAGE NOTE

This equipment is for use by developers and integrators. The manufacturer accepts no liability for damage or injury caused by the use of this product. It is the responsibility of the developer, integrators or other users of this product to:

- Ensure that all necessary and appropriate safety measures are taken.
- Obtain suitable regulatory approvals as may be required.
- Check power settings to all component parts before connection.

DISCLAIMER

There is no implied or expressed warranty regarding this material.

GENERAL SPECIFICATION

No.	Item	Description			
1	Model name	WVGA Panel	8520X480	NCB410WV4	Note 1)
		XGA Panel	1024X768	NCB410X4	
		WXGA Panel	1280X768	NCB410W4	
		WXGA Panel	1366X768	NCB410WZ4	
		UXGA Panel	1600X1200	NCB410U4	
		HD Panel	1920X1080	NCB410WH4	
		WUXGA Panel	1920X1200	NCB410WU4	
2	LCD Module	SVGA, XGA, WXGA, SXGA			
3	Signal Input	Analog RGB, TMDS(DVI). NTSC/PAL			
4	Resolution Support	H: 31 ~ 80kHz			
		V: 55 ~ 76Hz			
5	OSD Control	Menu, Left, Right, Up, Down, Source, Power			5 keys
	Plug & Play	VESA DDC 2B Ver1.3			
6	Power Connector	Input	Type: IEC320 MALE 3Line Connector		
7.	Power Consumption	Supply Voltage	12Vdc/15Vdc/18Vdc or 25Vdc		
		Max Power	18W (Without Back Light Inverter)		
8	Signal Connector	Analog	DSUB 15P(R, G, B Separate H, V Sync)		
		Digital	DVI-D(TMDS)		TMDS
		Video	MINIDIN-4P(SVHS), RCA(CVBS)		

Notes 1) Depends On Panel Resolution

- **WV : WVGA (850X480)**
- **X : XGA (1024X768)**
- **W : WXGA (1280X768)**
- **WZ : WXGA (1366X768)**
- **U : UXGA (1600x1200)**
- **WH : HD 1080i (1920x1080)**
- **WU : WUXGA (1920x1200)**

ELECTRICAL SPECIFICATION

Input characteristic

Description	Signal	Unit	Min	Typical	Max	Remarks
Power In (24V)						
	Input	Vdc	22.8	24.0	25.2	
	Consumption	Watt		TBD		Without INV
Power In (18V)						
	Input	Vdc	17.0	18.0	19.0	
	Consumption	Watt		TBD		Without INV
Power In (15V)						
	Input	Vdc	14.75	15.0	15.75	
	Consumption	Watt		TBD		Without INV
Power In (12V)						
	Input	Vdc	11.4	12.0	12.6	
	Consumption	Watt		TBD		Without INV
RGB Input						
	Analog RGB	Vp-p	0	0.7	-	
	Sync	Vdc	0	5	5.5	
	H Frequency	KHz	31		80	Depends on Mode
	V Frequency	Hz	55	60	75	
DVI Input						
	TMDS	mVp-p	450	500	900	
NTSC/PAL						
	Y/CVBS	Vp-p	0.7	1.0	1.4	
	C	Vp-p	0.6	0.8	1.0	

Output Characteristics

Description	Signal	Unit	Min	Typical	Max	Remarks
Panel Power						
	LCD Power (18V)	Vdc	17.1	18	18.9	Jumper option (Representative 12V)
	LCD Power (15V)	Vdc	14.25	15	15.75	
	LCD Power (12V)	Vdc	11.4	12	12.6	
	LCD Power(5V)	Vdc	4.75	5	5.25	Jumper option
	LCD Power(3.3V)	Vdc	3.13	3.3	3.46	Jumper option
LVDS Interface						
	Differential output	Vp-p (mV)	250	350	450	Different +/-
Inverter Interface						
	Power out	Vdc	22.8	24	25.2	Depends on Power Input and Spec.
			17.1	18	18.9	
			14.25	15	15.75	
			11.4	12	12.6	
	On/Off control	V	0		3.3	L=off, H=on
	Brightness control	V	3.3		0	Option
			0		4V	Option
			Step	0		100

SYSTEM DESIGN

A typical LCD based display system utilizing this controller is likely to comprise the following.

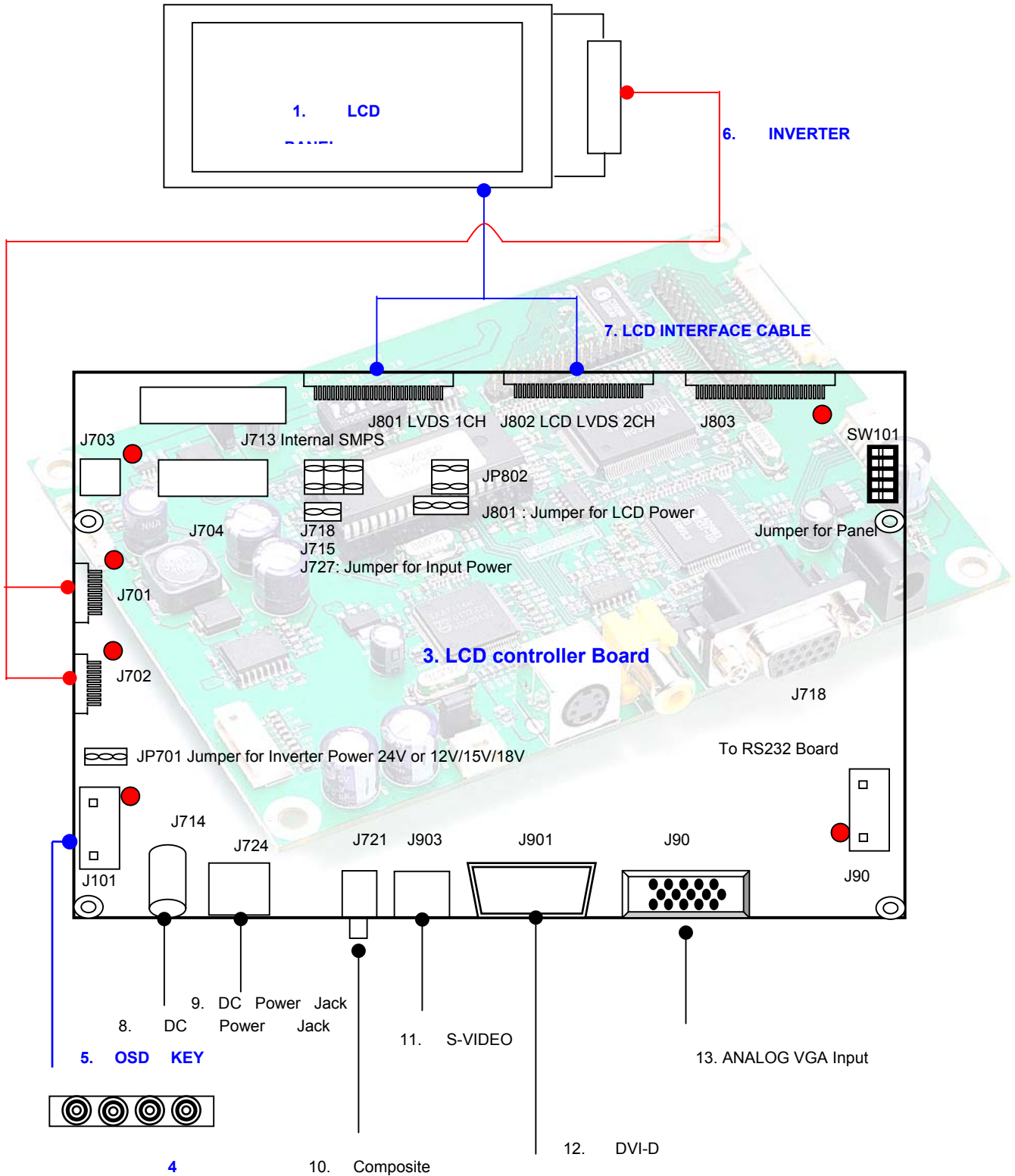

A typical PDP based display system utilizing this controller is likely to comprise the following.

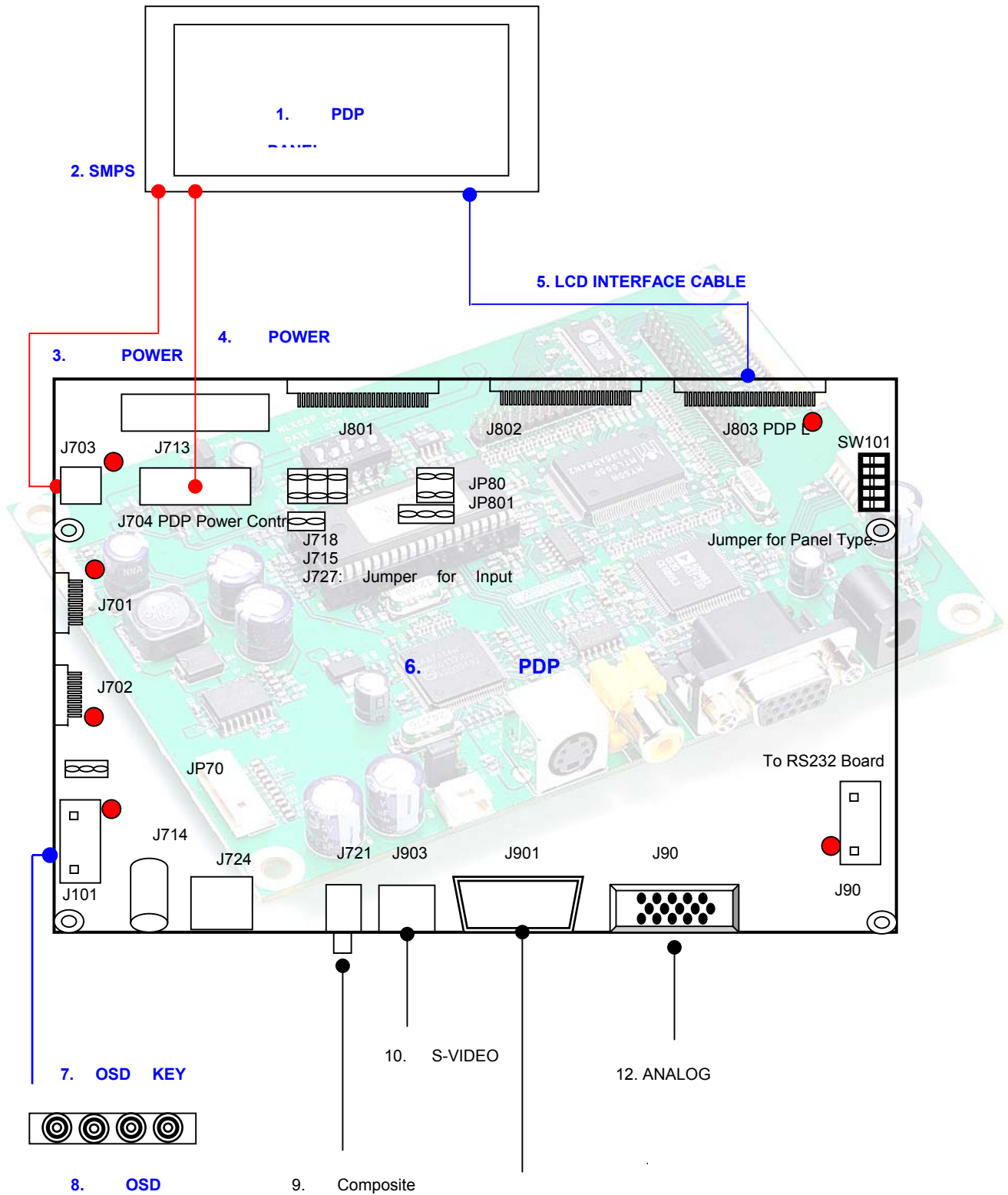

BLOCK DIAGRAM

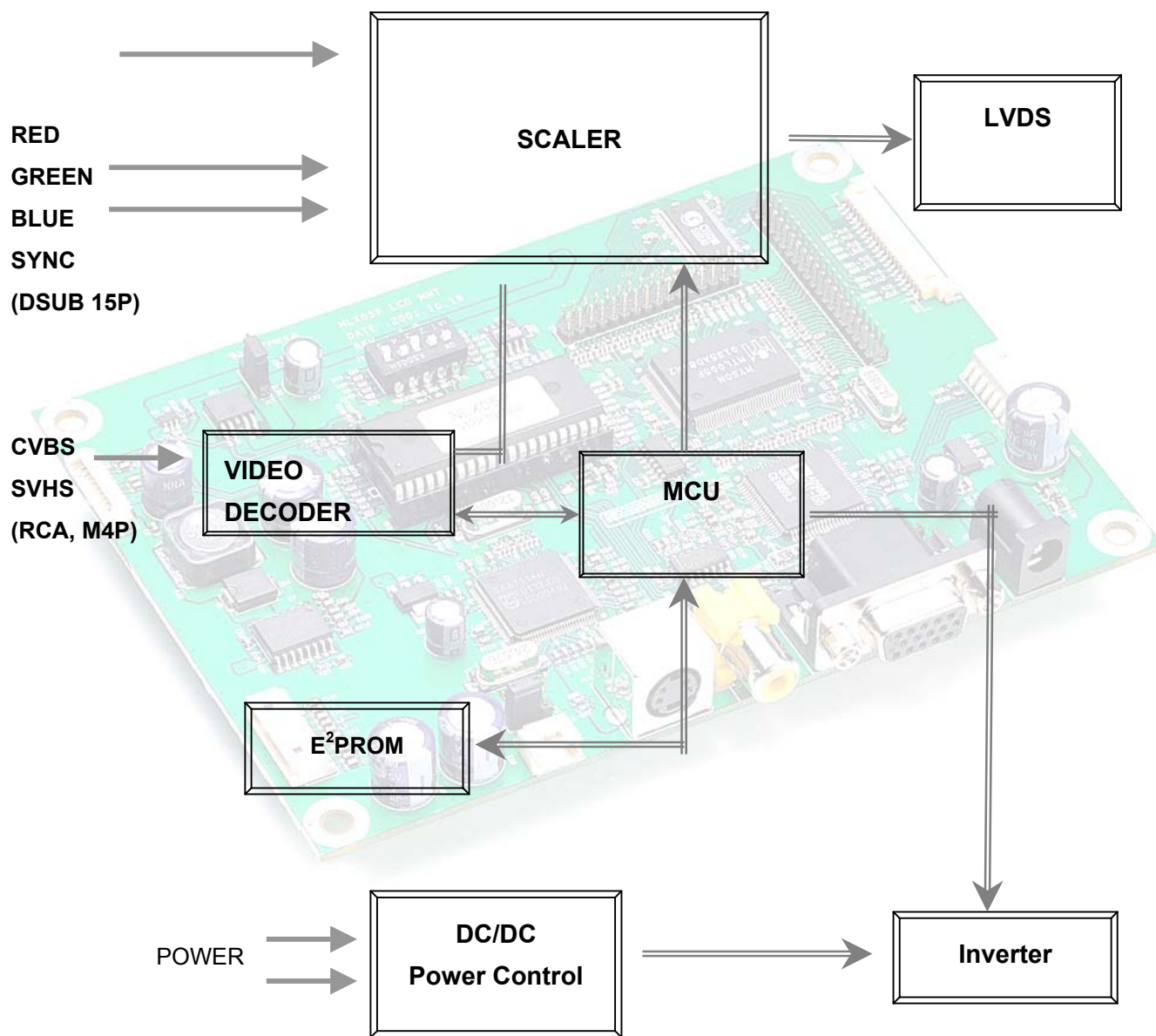

ASSEMBLY NOTES

This controller is designed for monitors and custom display projects using TFT (active matrix) LCD panels of 1280x768, 1366x768, 1600x1200, 1920x1080 and 1920x1200 resolutions, PDP panels of 852x480, 1024x768 and 1366x768 resolutions VGA, SVGA, XGA, WXGA, SXGA, WSXGA and UXGA signal input. The following provides some guidelines for installation and preparation of a finished display solution.

Preparation: Before preceding it is important to familiarize yourself with the parts making up the system and the various connectors, mounting holes and general layout of the controller. As much as possible connectors have been labeled. Guides to connectors and mounting holes are shown in the following relevant sections.

1. LCD Panel: This controller has LVDS interface logic on the Board for different kind of TFT LCD panel. Due to the different signal timing and electrical characteristics from each LCD panel manufacturer, for selecting LCD interface type and resolution, put jumper marked SW101 on the right position following LCD panel specification. For selecting DC power level, put jumper marked J801, J802 on the right position. Supplied power level depends on LCD panel specification.

PDP Panel: This controller has LVDS interface logic on the Board for different kind of PDP panel. Due to the different signal timing and electrical characteristics from each PDP panel manufacturer, for selecting LCD interface type and resolution, put jumper marked SW101 on the right position following PDP panel specification.

2. Controller: Handle the controller with care as static charge may damage electronic components, Make sure correct jumper and switches settings to match the target LCD and PDP panel

3. LCD connector board: Different makers and models of LCD panel require different panel signal connectors and different pin assignments.

PDP connector board: Different makers and models of LCD panel require different panel signal connectors and different pin assignments.

4. LVDS signal cables: In order provide a clean signal it is recommended that LVDS signal cables should not longer than 30cm. If loose wire cabling is utilized these can be a made into a harness with cable ties. Care should be taken when you place the cables to avoid signal interface. Additionally it may necessary in some systems to add ferrite cores to the cables to minimize signal noise.

5. Inverter: This will be required for the backlight of an LCD, some LCD panel have an inverter built in. As LCD panels may have 1 or more backlight tubes and the power requirements for different panel backlights may vary it is important to match the inverter in order to obtain optimum performance. See application notes for more information on connection

6. Inverter cable: Different inverter models require different cables and different pin assignment. Make sure the correct cable pin out to match the inverter. Unsuitable cable pins out may damage the inverter.

7. AV cable: Standard composite or S-video cables can be used. Reasonable quality cables should be used to avoid image quality degradation.

8. OSD Button: See Operational Function section.

9. 3 Color LED: This LED shows the state of controller.

- Green – Normal state
- Off – Off mode (Can't find video signals)
- Amber – DPMS mode

10. Power switch: This switch is located on OSD button board.

11. Power input: Proper power is required to supply power for the controller, the Inverter and the LCD panel

12. VGA Input Cable: As this may affect regulatory emission test result, a suitably shielded cable should be utilized.

EMI: Shielding will be required for passing certain regulatory emissions tests. Also the choice of video board and power supply can affect the test result.

Consideration should be given to:

- Electrical insulation.
- Grounding.
- EMI shielding.
- Heat & ventilation

Caution: Ensure that the adequate insulation is provided for all areas of the PCB with special attention to high voltage parts such as the inverter.

***** Remarks*****

For a specific panel use, One panel sample and full technical specifications for the LCD panel from the manufacturer are required to test for tuning up screen image.

13. Setup for operation

Once the circuit has been connected, a setup procedure for optimal is requires a few minutes the following instructions are likely to form the basis of the finished product operation manual.

PC Settings

The PC needs to be set to an appropriate graphics mode that has the same resolution with the LCD panel to have clear screen image. And the vertical refresh rate should be set to one of 56~75Hz, non – interlaced signal.

Display System Settings

The OSD (On Screen Display) provides certain functions to have clear image and others. This board supports 5 buttons OSD operation as a standard. The control functions defined on OSD operation are as below.

Pc Graphics Output: A few guidelines:

- Signal quality is very important, if there is noise or instability in the PC graphics output this may result in visible noise on the display
- Refer to the graphic modes table in specification section for supported modes.
- Non-interlaced & interlaced video input is acceptable.

Important: please read the application notes section for more information.

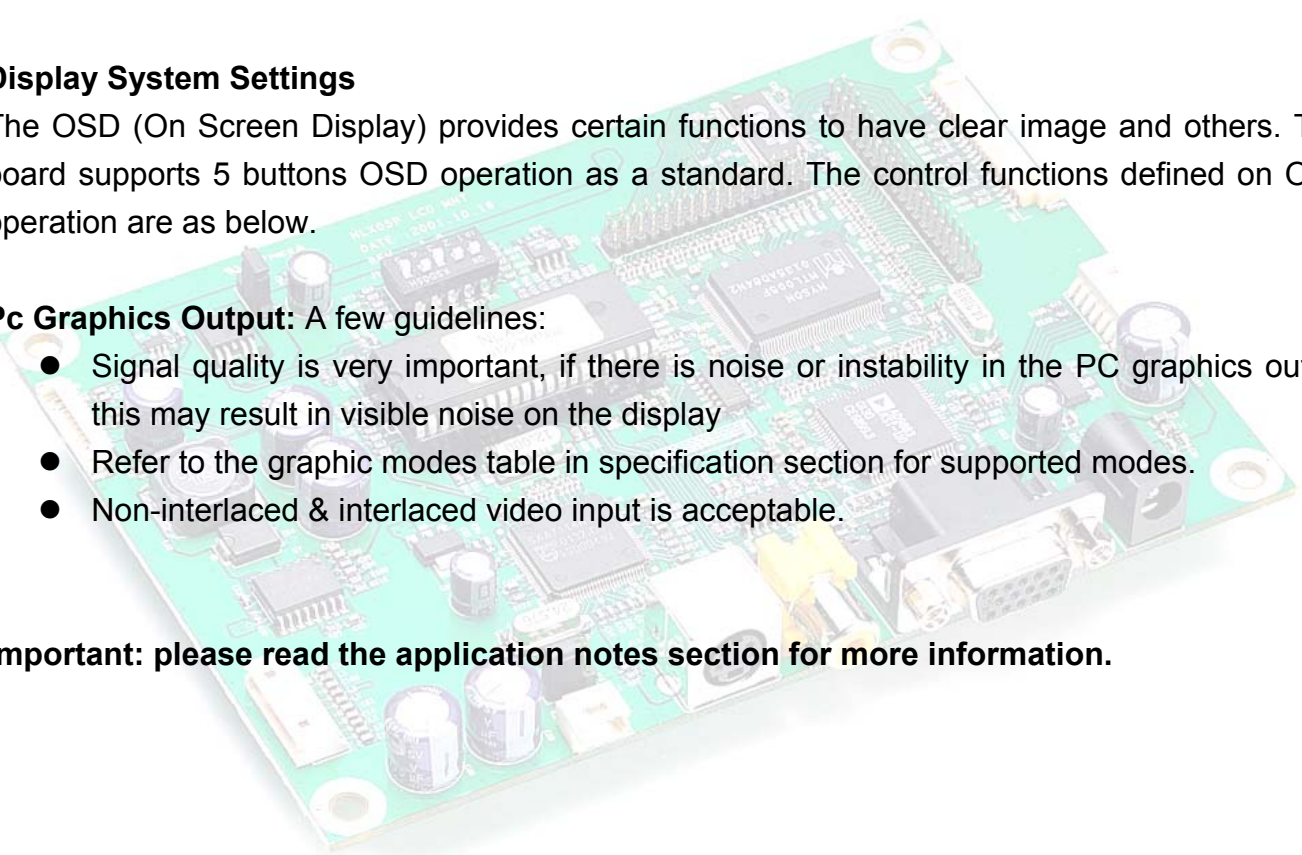

CONNECTION & OPERATION

CAUTION: Never connect or disconnect parts of the display system when the system is powered up as this may cause serious damage.

CONNECTION

- 1. LCD panel & Inverter:** Connect the inverter (if it is not built- in the panel) to the CCFT lead connector of the LCD panel.
PDP Panel & SMPS: Connect the SMPS (Built- in the panel) to the connector of the PDP panel.
- 2. LVDS type panels:** Plug the signal cables direct to J801 of the controller board for 1 channel interface panel or J802 for 2 channel interface panel. Plug the other end of cables to the LCD connector board. J803 to the PDP.
- 3. Inverter & Controller:** Plug the inverter cable to J701, 702 of the controller board and another end to the connector on the inverter.
- 4. Function switch & Controller:** Plug the OSD switch mount cable to J701 of the controller board and another end to the OSD board.
- 5. Jumpers:** Check all jumpers J12 (External power Setting), J701 (Input power Setting) and J801, 802 (Target Panel Power setting) are set correctly. Details referring the jumpers setting table (in the following section)
- 6. VGA cable & Controller:** Plug the VGA cable to the connector J902 of the controller board.
- 7. DIV-D Cable & Controller:** Plug the DVI-D Cable to the connector J901 of the controller board.
- 8. S/C Video Cable & Controller:** Plug S-Video Cable to the connector J903, C-Video Cable to the J721
- 9. Power supply to Controller:** Plug the DC 12V/18V power in to the connector J903 or DC 24V power in to the connector J721 of controller board.
- 10. Power on:** Switch on the controller board and panel by using the OSD switch mount.

General:

- If you use supplied cables & accessories, ensure that they are correct for the model of the panel and the controller.
- If you make your own cables & connectors, refer carefully to both the panel & inverter specifications and the section in this manual, “Connectors, Pin outs & Jumpers” to ensure the correct pin to pin wiring.

PC Setting:

The controller has been designed to take a very wide range of input signals however to optimize the PC’s graphic performance we recommend choosing 60Hz vertical refresh rate –

this will not cause screen flicker.

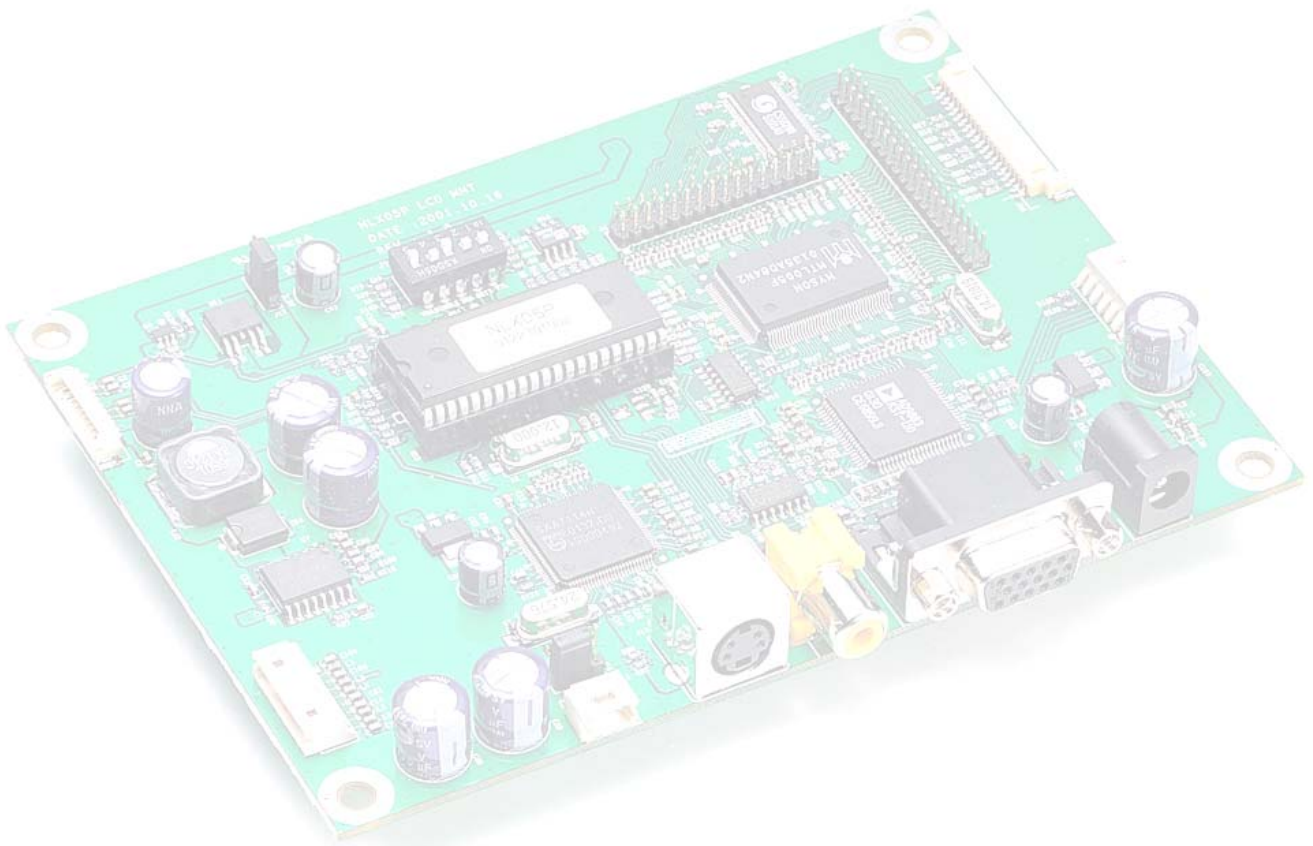

OSD Control Board

The OSD (On Screen Display) provides certain functions to have clear image and others. This board supports 7 buttons OSD operation as a standard. The control functions defined on OSD operation are as below. (unit: mm)

Appearance

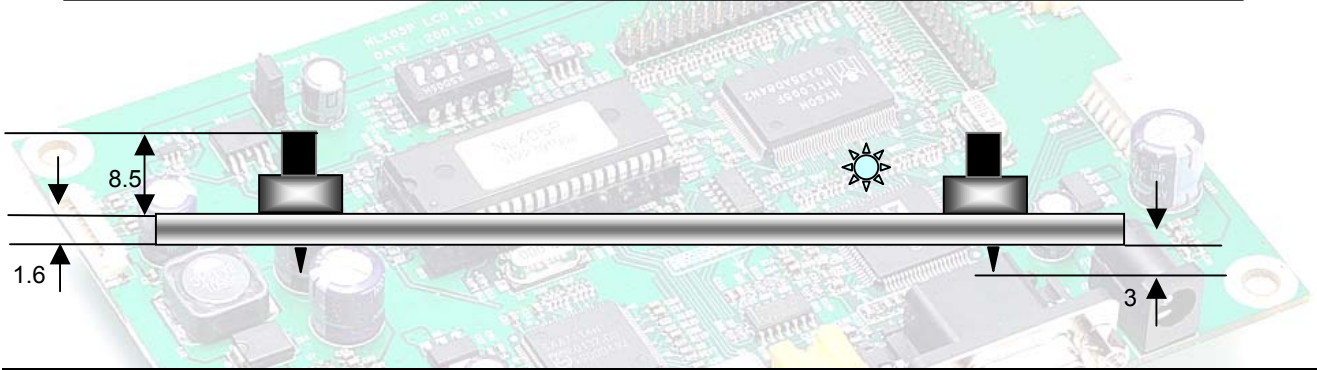
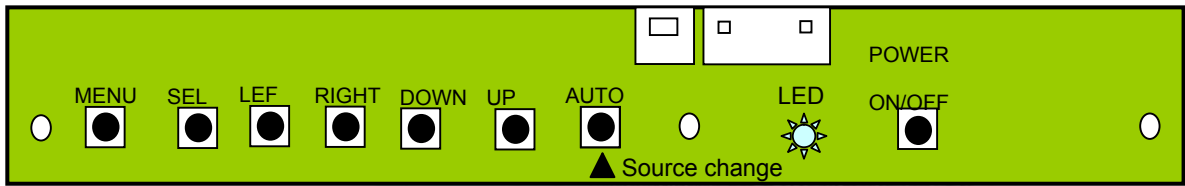

Button	Function	Status	HOT Key
LED	Indicates operation status	Green/ Off/ Amber	
Power	Power on/off	On/Off	
Menu	Activate menu		
Select	Menu Select		No OSD, Source
LEFT	Cursor control Left		
RIGHT	Cursor control Right		
DOWN	Cursor control Down		
UP	Cursor control Up		

The chosen OSD settings will be stored in memory. The OSD menu can be cleared from the screen from the screen by moving the selection bar to the **EXIT MENU** icon pressing the **SEL** button otherwise it will be automatically cleared after a few second of non-use

OSD MAIN MENU



MAIN MENU	SUB MENU	CONTROL		
PICTURE	PSM	Dynamic/Standard/Mild/Game/User		VIDEO
		USER	Brightness, Contrast, Color, Sharpness	
	CSM	CSM/Brightness/Contrast		PC
		CSM	Normal/Warm/User	
User		Red/Green/Blue		
PIP/POP/PBP	ON/OFF	ON	PIP	Source, Swap, PIP Size, PIP Position
			POP, PBP	Source, Swap
SETUP	Language	English/Deutsch/François/Italiano/Espanol		
	Transparency	50 (1 ~100)		
	ARC	Auto/16:9/14:9/4:3		AV/TV : PAL
		16:9/14:9/4:3		AV/TV : NTSC
		4:3/16:9		PC
	ISM Method	Normal, Orbit, White		
Factory Reset	On/Off			
SCREEN	Auto Configure	On/Off		RGB PC
	H Position	50(0 ~ 100)		
	V Position	50(0 ~ 100)		
	Clock	50(0 ~ 100)		
	Phase	50(0 ~ 100)		

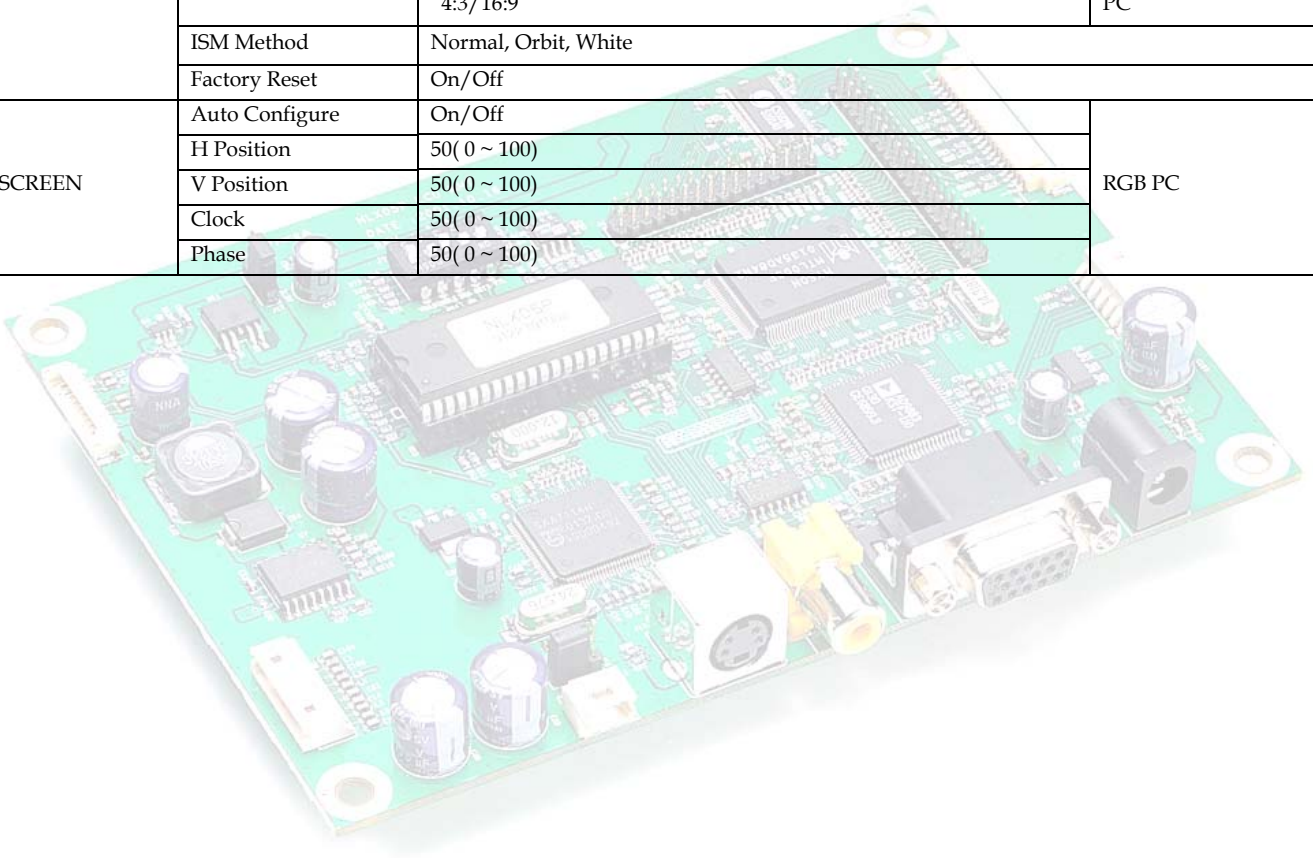

CONNECTOR, PINOUT & JUMPERS

The various connectors are:

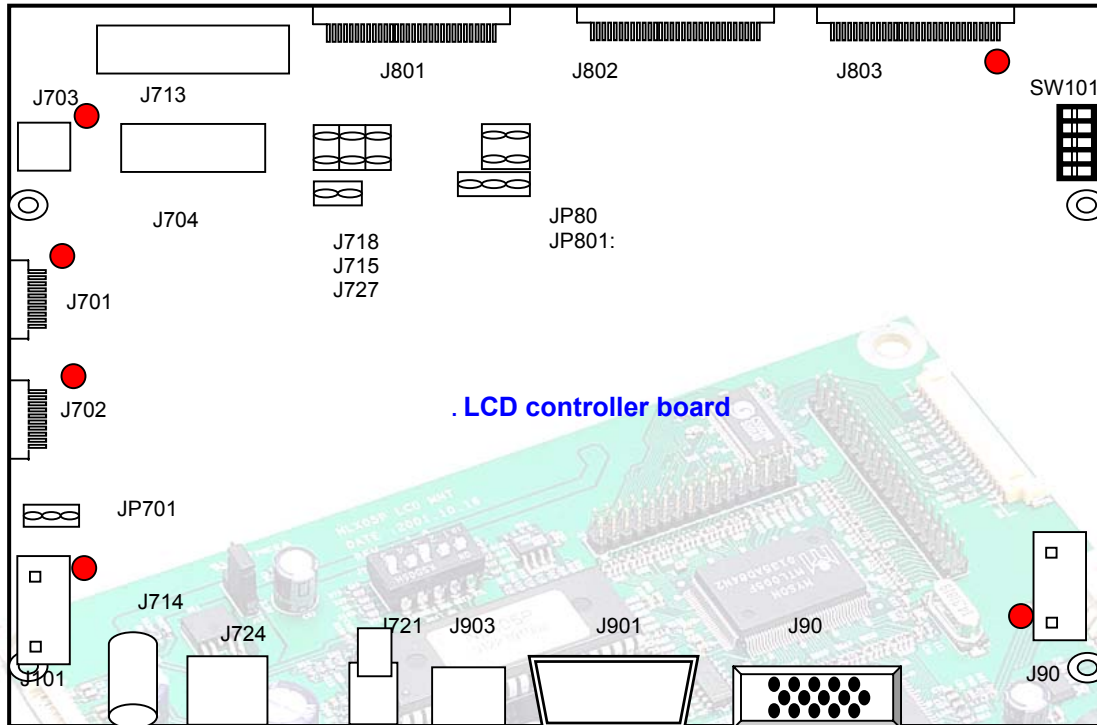

Summary

Reference	Item	Description	Type	Manufacture
SW101	Switch	Panel Type Select Switch	HDR5X2	-
J101	Connector	To OSD Board	SMW200-0710	YEONHO
JP701	Jumper	Inverter Power Jumper	HDR3X1	-
J701, J702	Connector	Inverter Connector	12505WR-1090	YEONHO
J703	Connector	24V Power Input	SMW200-0410	YEONHO
J704	Connector	PDP Power Control	SMW200-0710	YEONHO
J713	Connector	Internal SMPS Power Input	SMW200-1410	YEONHO
J714	Jack	Input Dc power Jack	2.5Ø	-
J715	Jumper	Internal SMPS Power Selection	HDR3X1	-
J718	Jumper	Internal SMPS Power Selection	HDR3X1	-
J727	Jumper	Internal SMPS Power	HDR2X1	

		Selection		
J721	Jack	C-video Input	RCA(Yellow)	-
J724	Connector	Input Dc power Jack	KPJ-4S-S	KYCON
JP801	Connector	Output Power Jumper	HDR2X2	-
JP802	Connector	Output Power Jumper	HDR3X1	-

Referenc e	Item	Description	Type	Manufacture
J801	Connector	LVDS Single Interface for LCD	12507WR-20	YEONHO
J802	Connector	LVDS Dual Interface for LCD	12507WR-30	YEONHO
J803	Connector	LVDS Single Interface for PDP	12507WR-30	YEONHO
J901	Connector	DVID-D Input (TMDS)	DVI-D24P	-
J902	Connector	Analog RGB Input	15P D-SUB	-
J903	Jack	S-video Input	MJ373(MINIDIN 4PIN)	-
J904	Connector	To RS232 Interface Board	SMW200-0410	YEONHO

SW101: Panel Type Select Switch

J101 : OSD control connector

Pin No.	Symbol	Description
1	Vcc	+5V power for IR sensor
2	IRQ	Infrared rays signal line.
3	LED2	RED LED
4	LED1	GREEN LED
5	GND	Ground
6	KEY1	Up, Power
7	KEY0	Menu, Select, Down

JP701: On board +24V/+12V Inverter power select jumper

Pin No.	Symbol	Description
---------	--------	-------------

1	12V	<i>representative 12V/18V, depends on power supply from J2</i>
2	B+	<i>Inverter power selected by J14' Jumper</i>
3	24V	<i>24V from J22</i>

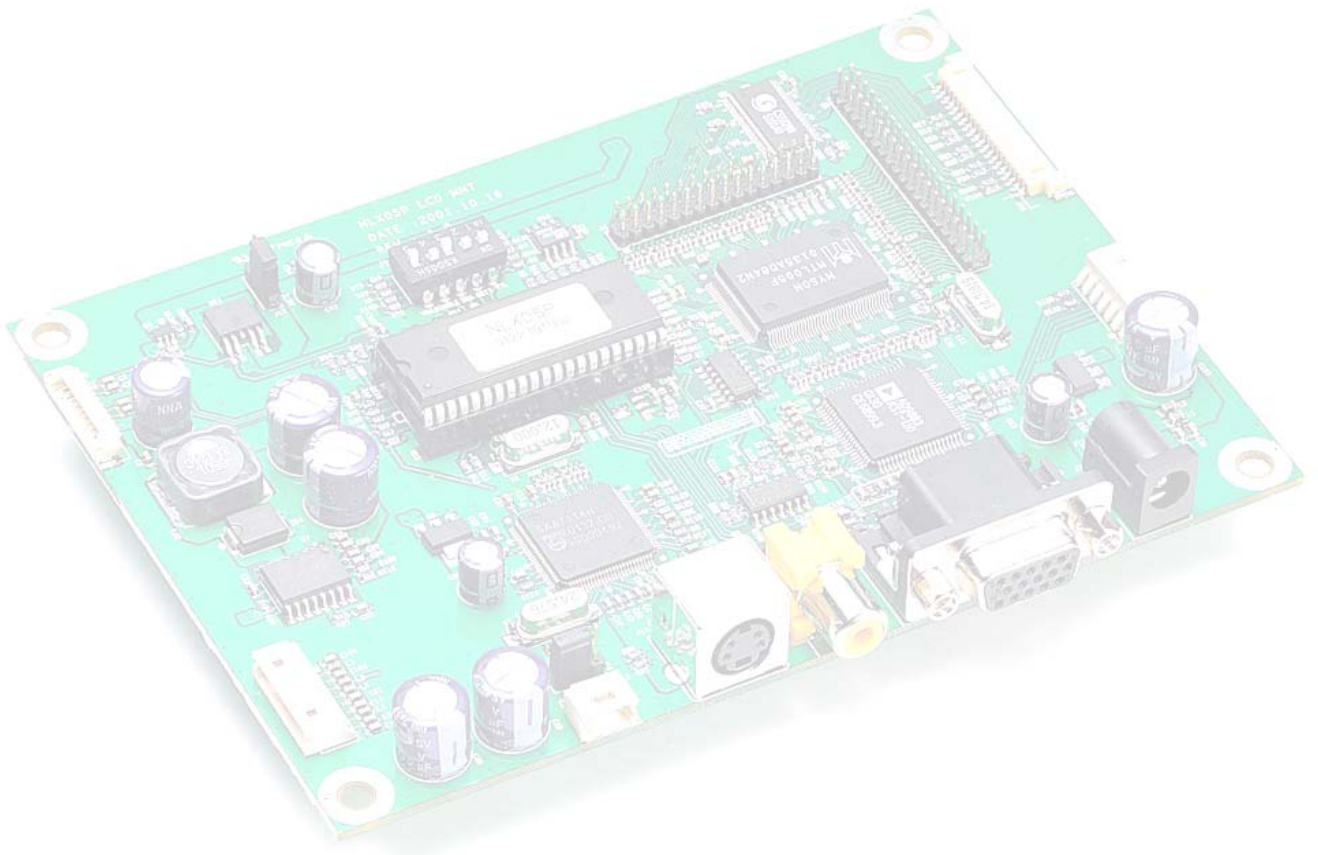

J701, J702: Backlight Inverter connector

Pin No.	Symbol	Description
1	DIM-ADJ	DIM-adjustment analog dimming control signal * make sure inverter specification
2	ON/OFF	Inverter digital ON(3.3V)/OFF(0V) signal
3,4,5,6	GND	Ground
7,8,9,10	B+	B+(24V or 12/18V)

J724: +24V DC input power supply

Pin No	Symbol	Description
1 3	GND	Ground
2 4	Vcc	24V

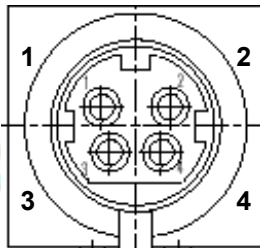

J703: +24V DC power supply

Pin No	Symbol	Description
1 2	Vcc	24V
3 4	GND	Ground

J704: PDP Power Control

Pin No.	Symbol	Description	I/O	Remarks
1	ACD-DET	AC Power Detection	I	5V ± 5%
2	PWR-ON	RLY On/Off Control Signal	O	5V ± 5%
3	5VS	5V Standby Power	I	Max 1.2A
4	GND	Ground		
5	INV-CTRL	VS On Control Signal	O	
6	POD	5VD Power On Detection	I	
7	GND	Ground		

J713: Internal SMPS Input Power Supply

<i>Pin No.</i>	<i>Symbol</i>	<i>Description</i>	<i>I/O</i>	<i>Remarks</i>
1	NC	No Connection		
2	GND	Ground		
3,4	12V	12V Logic Power Supply	I	Max 1.0A
5,6	GND	Ground		
7,8	5VIN	5V Logic Power Supply	I	Max 1.0A
9	5VS	5V Standby Power Supply	I	
10,11	GND	Ground		
12	PWR_ON	SMPS Power On Control Signal	O	3.3V(High) :On
13	INV_DIM	Inverter Dimming Control Signal	O	
14	INV_CTRL	Inverter ON/OFF Control Signal	O	

J715, J718, J127 : Power Selection Jumper

J801, J802 : LCD Power Selection Jumper

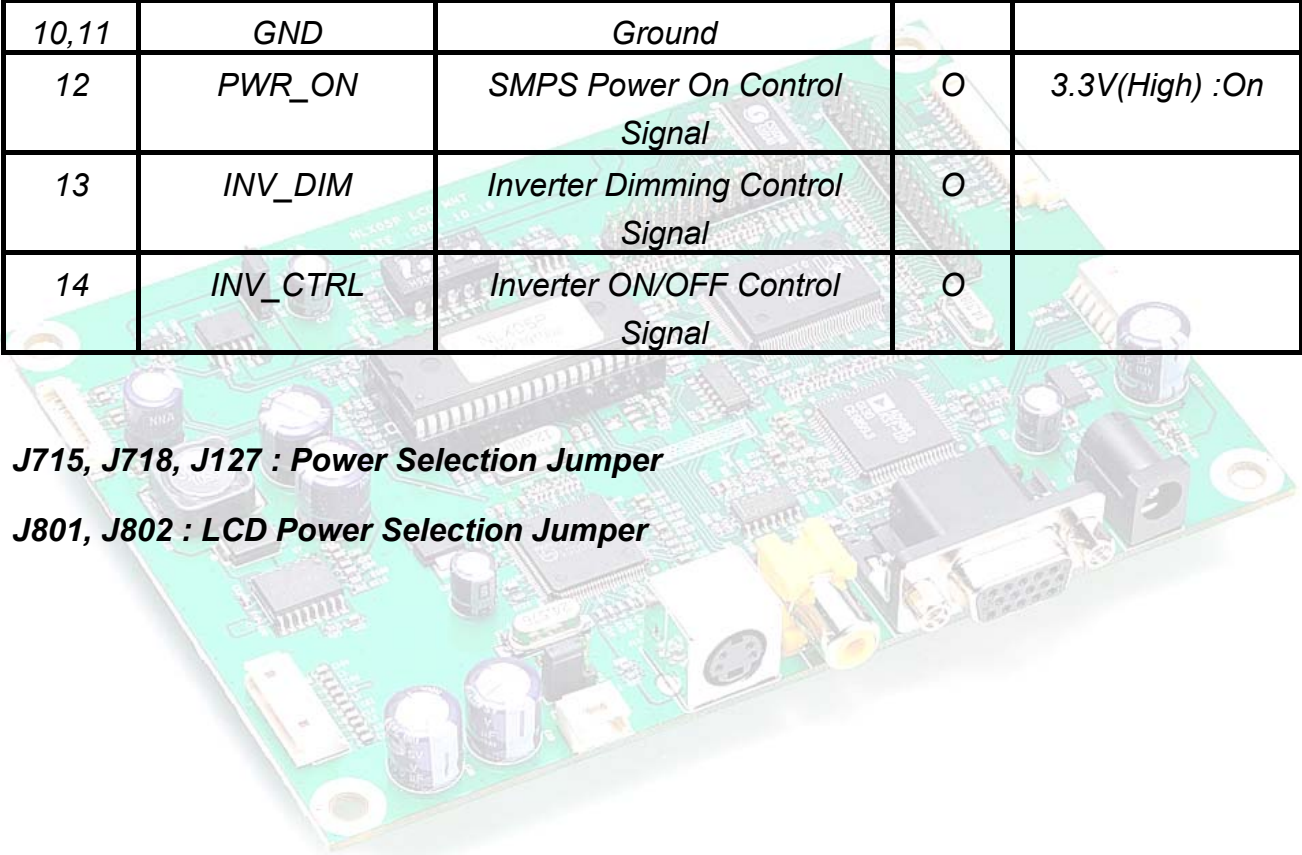

J801: LCD Interface connector for 1 Ch LVDS type

<i>Pin No.</i>	<i>Symbol</i>	<i>Description</i>
1	GND	Ground
2	GND	Ground
3	Y3P	LVDS 3 Channel Positive Signal for LCD Module (6Bit Unused)
4	Y3M	LVDS 3 Channel Negative Signal for LCD Module (6Bit Unused)
5	GND	Ground
6	CLKOUTP	LVDS Clock Positive Signal of Channel for LCD Module
7	CLKOUTM	LVDS Clock Negative Signal of Channel for LCD Module
8	GND	Ground
9	Y2P	LVDS 2 Channel Positive Signal for LCD Module
10	Y2M	LVDS 2 Channel Negative Signal for LCD Module
11	GND	Ground
12	Y1P	LVDS 1 Channel Positive Signal for LCD Module
13	Y1M	LVDS 1 Channel Negative Signal for LCD Module
14	GND	Ground
15	Y0P	LVDS 0 Channel Positive Signal for LCD Module
16	Y0M	LVDS 0 Channel Negative Signal for LCD Module
17	GND	Ground
18	GND	Ground
19	MOD_PWR	VDD For LCD Module(12V/18V, 5V or 3.3V)
20	MOD_PWR	VDD For LCD Module(12V/18V, 5V or 3.3V)

J802: LCD Interface connector for 2 Ch LVDS type

<i>Pin No.</i>	<i>Symbol</i>	<i>Description</i>
1	MOD_PWR	Panel Power (12V/18V, 5V or 3.3V)
2	MOD_PWR	Panel Power (12V/18V, 5V or 3.3V)
3	MOD_PWR	Panel Power (12V/18V, 5V or 3.3V)
4	MOD_PWR	Panel Power (12V/18V, 5V or 3.3V)
5	GND	Ground
6	SELLDS	LVDS DATA ORDER SELECT(Depends on Panel)/ No Connection
7	GND	Ground
8	Y3P-EVEN	Positive(+) LVDS differential first 3 data(A port)
9	Y3M-EVEN	Negative(-) LVDS differential first 3 data(A port)
10	YCP-EVEN	Positive(+) LVDS differential first Clock(A port)
11	YCM-EVEN	Negative(-) LVDS differential first Clock(A port)
12	Y2P-EVEN	Positive(+) LVDS differential first 2 data(A port)
13	Y2M-EVEN	Negative(-) LVDS differential first 2 data(A port)
14	GND	Ground
15	Y1P-EVEN	Positive(+) LVDS differential first 1 data(A port)
16	Y1M-EVEN	Negative(-) LVDS differential first 1 data(A port)
17	YOP-EVEN	Positive(+) LVDS differential first 0 data(A port)
18	Y0M-EVEN	Negative(-) LVDS differential first 0 data(A port)
19	GND	Ground
20	Y3P-ODD	Positive(+) LVDS differential second 3 data(B port)
21	Y3M-ODD	Negative(-) LVDS differential second 3 data(B port)
22	YCP-ODD	Positive(+) LVDS differential second Clock(B port)
23	YCM-ODD	Negative(-) LVDS differential second Clock(B port)
24	Y2P-ODD	Positive(+) LVDS differential second 2 data(B port)
25	Y2M-ODD	Negative(-) LVDS differential second 2 data(B port)
26	GND	Ground
27	Y1P-ODD	Positive(+) LVDS differential second 1 data(B port)
28	Y1M-ODD	Negative(-) LVDS differential second 1 data(B port)
29	YOP-ODD	Positive(+) LVDS differential second 0 data(B port)
30	Y0M-ODD	Negative(-) LVDS differential second 0 data(B port)

J803: PDP Interface connector for LVDS type

<i>Pin No.</i>	<i>Symbol</i>	<i>Description</i>
1,2	NC	No Connection
3,4	GND	Ground
5	SLE	Serial Interface Enable Control Signal
6	SCLK	Serial Interface Clock
7	SDATA	Serial Interface Data
8	DISPEN	Display Enable Control Signal
9	GND	Ground
10	RE+	LVDS E Channel Positive Signal
11	RE-	LVDS E Channel Negative Signal
12	GND	Ground
13	RD+	LVDS D Channel Positive Signal
14	RD-	LVDS D Channel Negative Signal
15	GND	Ground
16	RCLK+	LVDS Clock Channel Positive Signal
17	RCLK-	LVDS Clock Channel Negative Signal
18	GND	Ground
19	RC+	LVDS C Channel Positive Signal
20	RC-	LVDS C Channel Negative Signal
21	GND	Ground
22	RB+	LVDS B Channel Positive Signal
23	RB-	LVDS B Channel Negative Signal
24	GND	Ground
25	RA+	LVDS A Channel Positive Signal
26	RA-	LVDS A Channel Negative Signal
27,28	GND	Ground
29,30	NC	No Connection

J904: To RS232 Board

<i>Pin No.</i>	<i>Symbol</i>	<i>Description</i>
1	<i>RXD</i>	<i>UART Rx</i>
2	<i>TXD</i>	<i>UART TX</i>
3	<i>GND</i>	<i>Ground</i>
4	<i>5VS</i>	<i>+5V power for RS232 Device</i>

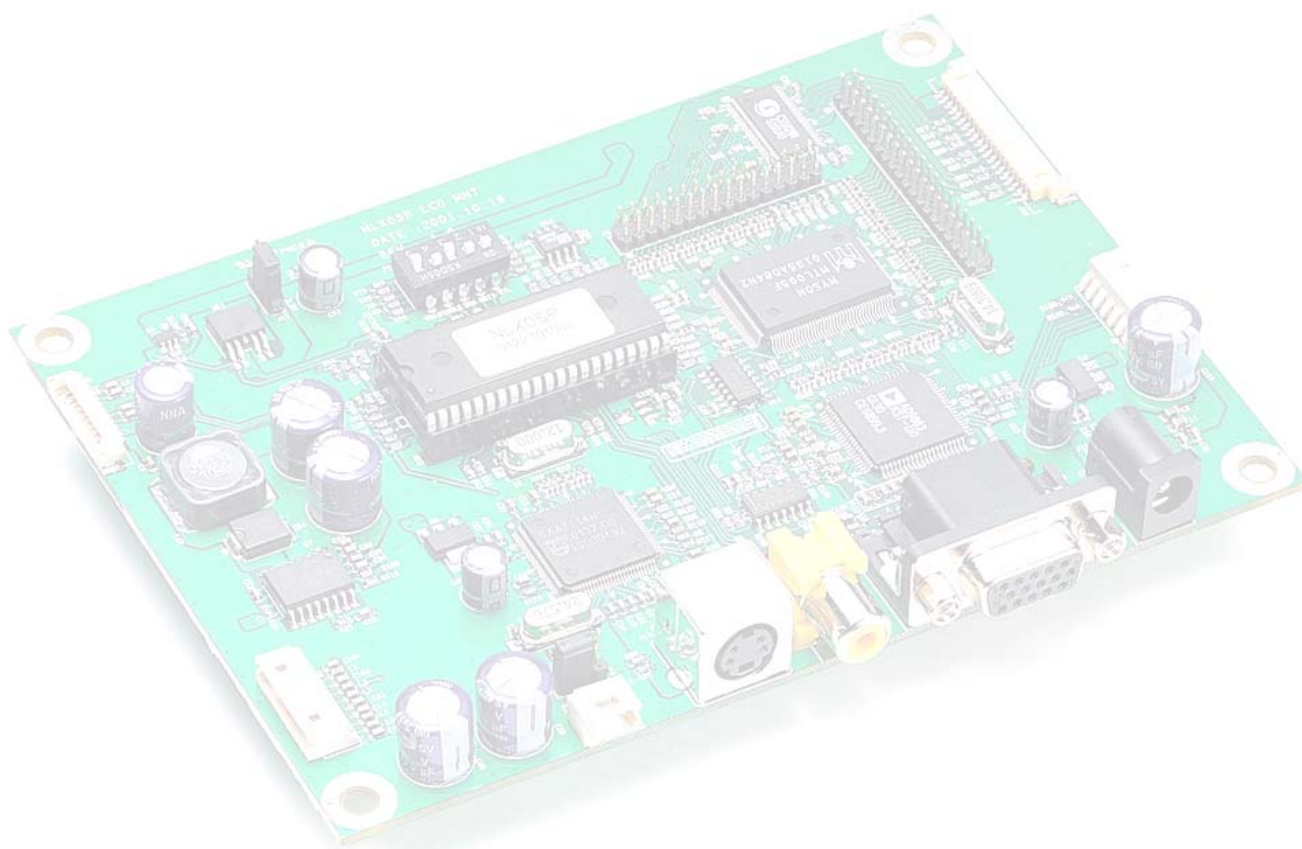

Summary: jumpers setting

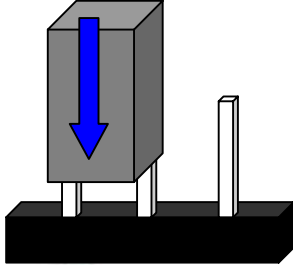
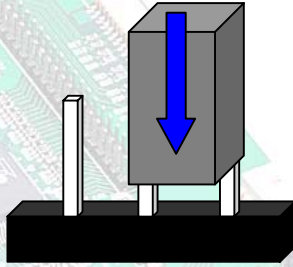
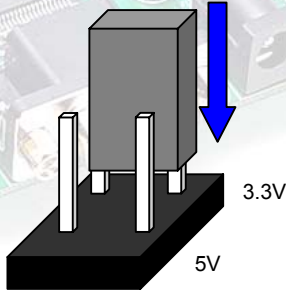
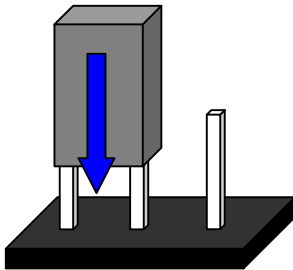
Reference	Description	Connector Type
JP701	+24V inverter power enable	 <p>24V 12V</p>
	+12/18V inverter power enable	 <p>24V 12V</p>
J802	5.0V or 3.3V panel power CAUTION: Incorrect setting can damage panel	 <p>3.3V 5V</p>
J801	12V panel power CAUTION: Incorrect setting can damage panel (12P from Internal SMPS 12V from External PSU)	 <p>12VP 12V</p>

*** Power operation scheme:**

- 24V power supply from J724, 12V power generated by DC/DC converter so all 12V as marked 12V

- 12V, 15V or 18V from J714, marked 12V is representative 12V, 15V or 18V as well as power supply

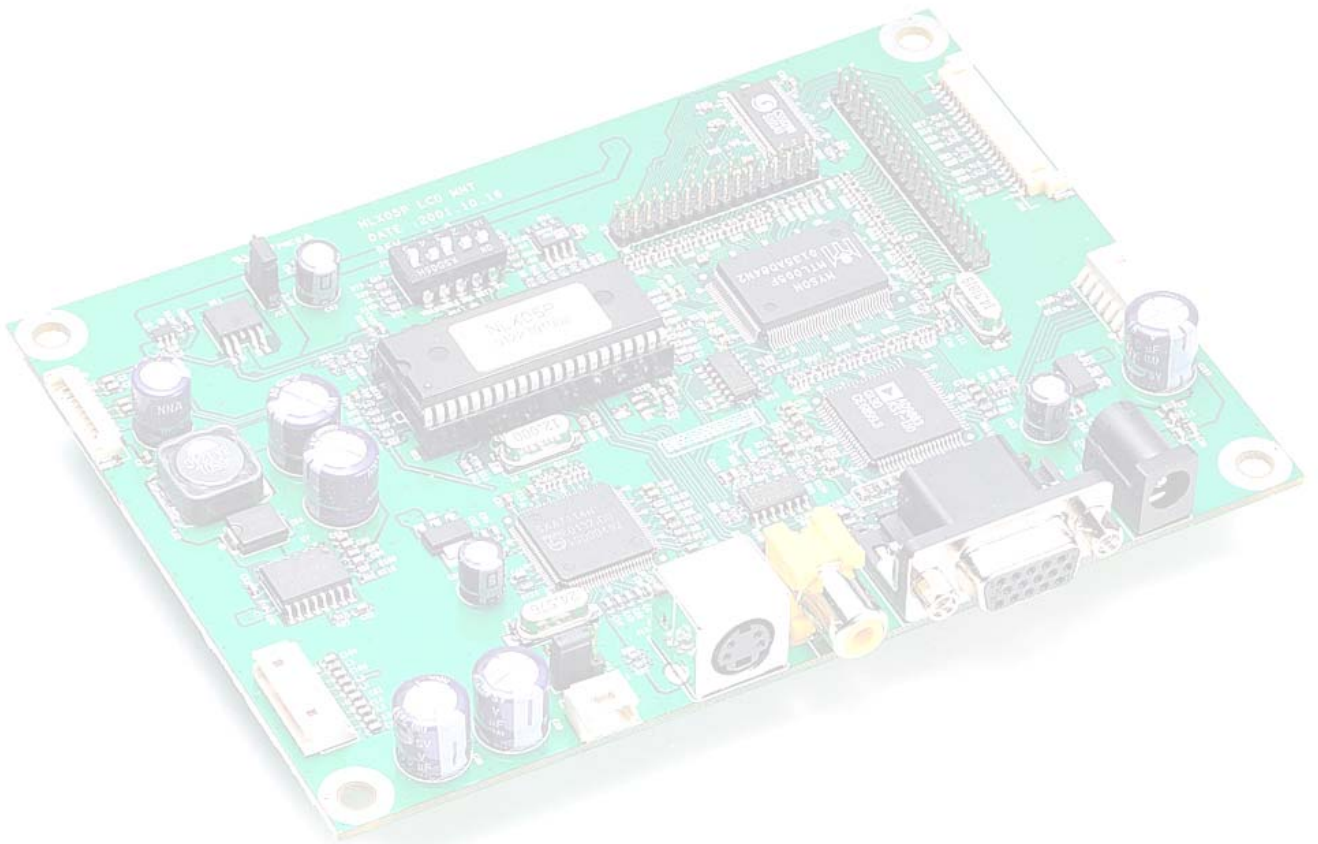

POWER SELECTION

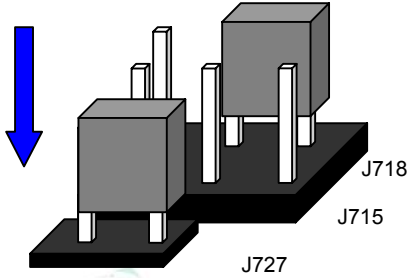
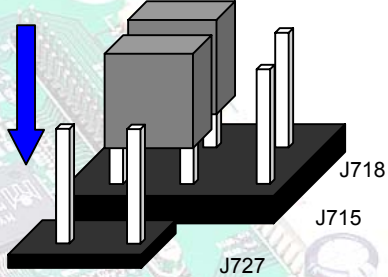
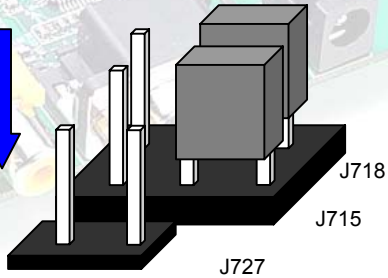
Target	J727	J718	J715	
PDP Internal SMPS	Short	1-2	Open	
LCD Internal SMPS	Open	2-3	2-3	
LCD External PSU	Open	1-2	1-2	

CONTROLLER DIMENSIONS

Mounting Hole position will be changed next version.

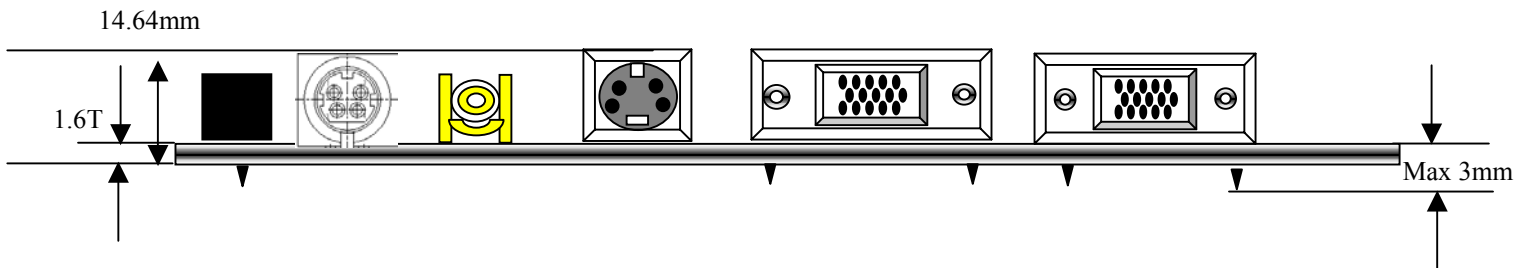
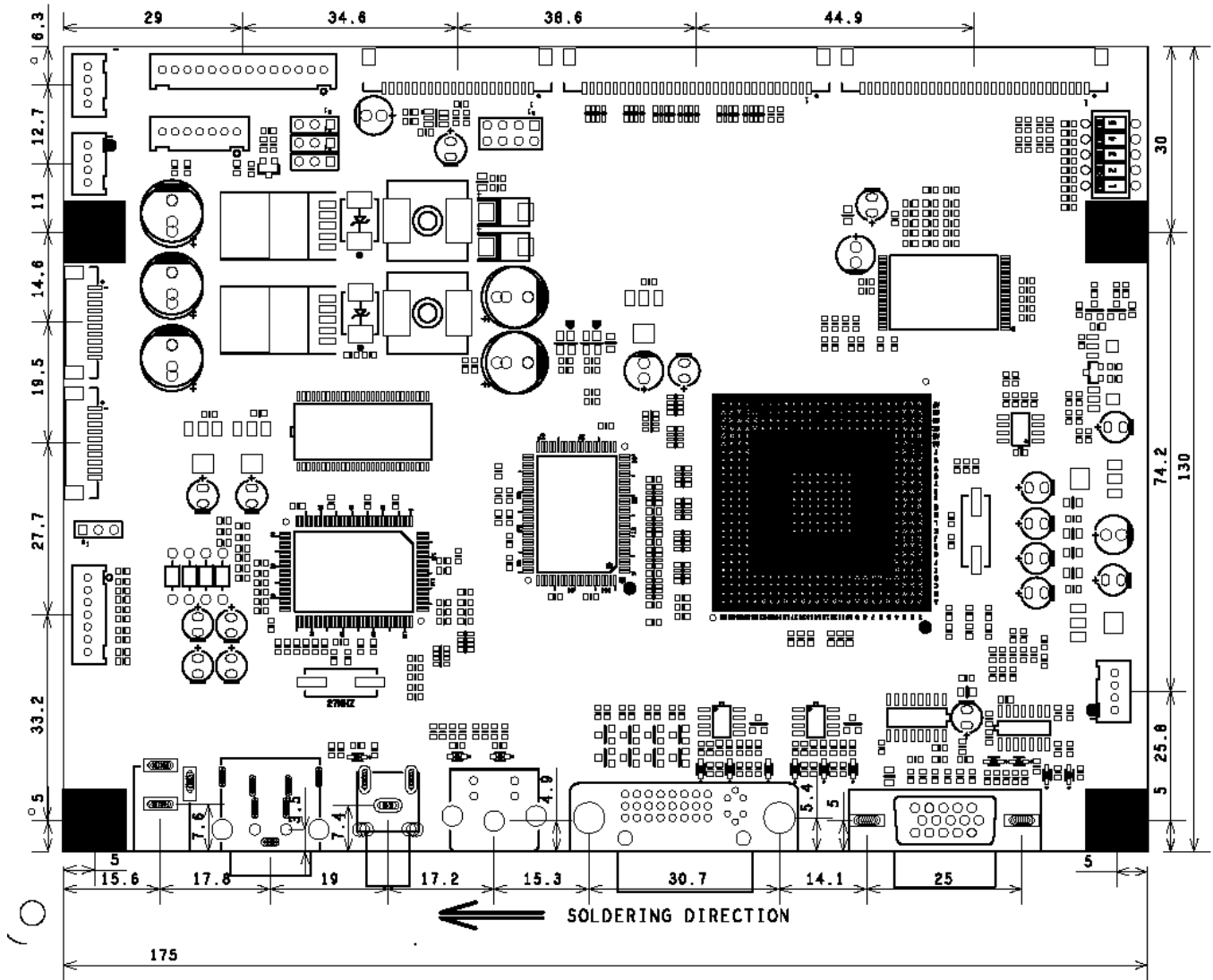

APPLICATION NOTES

USING THE CONTROLLER WITHOUT BUTTONS ATTACHED

This is very straightforward:

- Firstly setup the controller/display system with the buttons. With the attached controllers and display system active make any settings for color, contrast and image position as required then switch everything off.
- Remove the control switches, the 7-way cable.
- Refer to inverter specifications for details as to fixing brightness to a desired level, this may require a resistor, an open circuit or closed circuit depending on inverter

INVERTER CONNECTION

There are 3 potential issues to consider with inverter connection:

- Power
- ON/OFF
- Brightness (DIM-ADJ)

Inverter power: This should be matched with the inverter specification.

Inverter ON/OFF: This is a pin provided on some inverter for ON/OFF function and is used by this panel controller for VESA DPMS compliance. If the inverter does not have on/off pin or the on/off pin is not used DPMS will not operate. Pin 5 should be matched to the inverter specification for the ON/OFF pin.

Brightness Dimming control: NCB410 controller boards are analog dimming control method. And it is important to consider the specifications for the inverter to be used.

TROUBLESHOOTING

General

A general guide to troubleshooting of a flat panel display system it worth considering the system as separate elements, such as:

- ▶ Controller (jumpers, PC settings)
- ▶ Panel (controller, cabling, connection, panel, PC settings)
- ▶ Backlight (inverter, cabling, connection, panel, Pc settings)
- ▶ Cabling
- ▶ Computer system (display settings, operating system)

Through checking the system step-by-step cross with instruction manuals and a process of elimination to isolate the problem it is usually possible to clearly identify the problem area.

No image:

- ▶ If the panel backlight is not working it may still be possible to see just some image.
- ▶ A lack of image is most likely to be caused by incorrect connection, lack of power, failure to provide a signal or incorrect graphic card settings.

Image position:

If it is impossible to position the image correctly, the image adjustment controls will not move the image far enough, then test using another graphics card. This situation can occur when a graphic card is not close to standard timing or when something is in the graphics line that may affect the signal such as a signal splitter (please note that normally a signal splitter will not have any adverse effect).

Image appearance:

- ▶ A faulty panel can have blank lines, failed sections, flickering or flashing display.
- ▶ Incorrect graphic card refresh rate, resolution or interlaced mode will probably cause the image to be the wrong size, to scroll to, flicker badly or possibly even no image.
- ▶ Incorrect jumper settings on the controller may cause everything from incorrect image viewing to total failure.

CAUTION: Do not set the panel power input incorrectly.

- ▶ Sparkling on the display: faulty panel signal cable.

Backlight:

Items to check include: Power input, controls, inverter and Tubes generally in this order.

If half the screen is dimmer than the other half:

- ▶ Check cabling for the inverter.

Also:

- ▶ If system does not power down when there is a loss of signal.

APPLICABLE GRAPHIC MODE

The microprocessor measures the, H – sync V – sync and polarity for RGB Inputs, and uses this timing information to control all of the display operation to get the proper image on a screen. This board can detect all VESA standard Graphic modes shown on the table below and Provide more clear and stable image on a screen

Table 6.1) RGB input format

Spec Mode	Pixel Freq.	Horizontal Timing				Vertical Timing			
		Syn c Pola r	Freq.	Total	Activ e	Syn c Pola r	Freq.	Tota l	Active
	MHz	KHz	Pixel	Pixel	Hz	Line	Line	Line	
640*350@70Hz	25.144	P	31.430	800	640	N	70.000	449	350
640*400@70Hz	28.287	N	31.430	800	640	P	70.000	449	400
720*400@70Hz	28.287	N	31.430	900	720	P	70.000	449	400
640*480@60Hz	28.175	N	31.469	800	640	N	59.940	525	480
640*480@72Hz	31.500	N	37.861	832	640	N	72.809	520	480
640*480@75Hz	31.500	N	37.500	840	640	N	75.000	500	480
800*600@56Hz	36.000	P	35.156	1024	800	P	56.250	625	600
800*600@60Hz	40.000	P	37.879	1056	800	P	60.317	628	600
800*600@72Hz	50.000	P	48.077	1040	800	P	72.188	666	600
800*600@75Hz	49.500	P	46.875	1056	800	P	75.000	625	600
1024*768@60Hz	65.000	N	48.363	1344	1024	N	60.005	806	768
1024*768@70Hz	75.000	N	56.476	1328	1024	P	70.070	806	768

1024*768@75 Hz	78.750	P	60.02 3	1312	102 4	P	75.03 0	800	768
1280*1024@6 0Hz	108.000	P	63.98 1	1688	128 0	P	60.02 0	106 6	1024
1280*1024@7 5Hz	135.000	P	79.97 6	1688	128 0	P	75.03 5	106 6	1024
1600*1200@6 0Hz	162,000	P	75,00 0	2160	160 0	P	60.00	125 0	1200

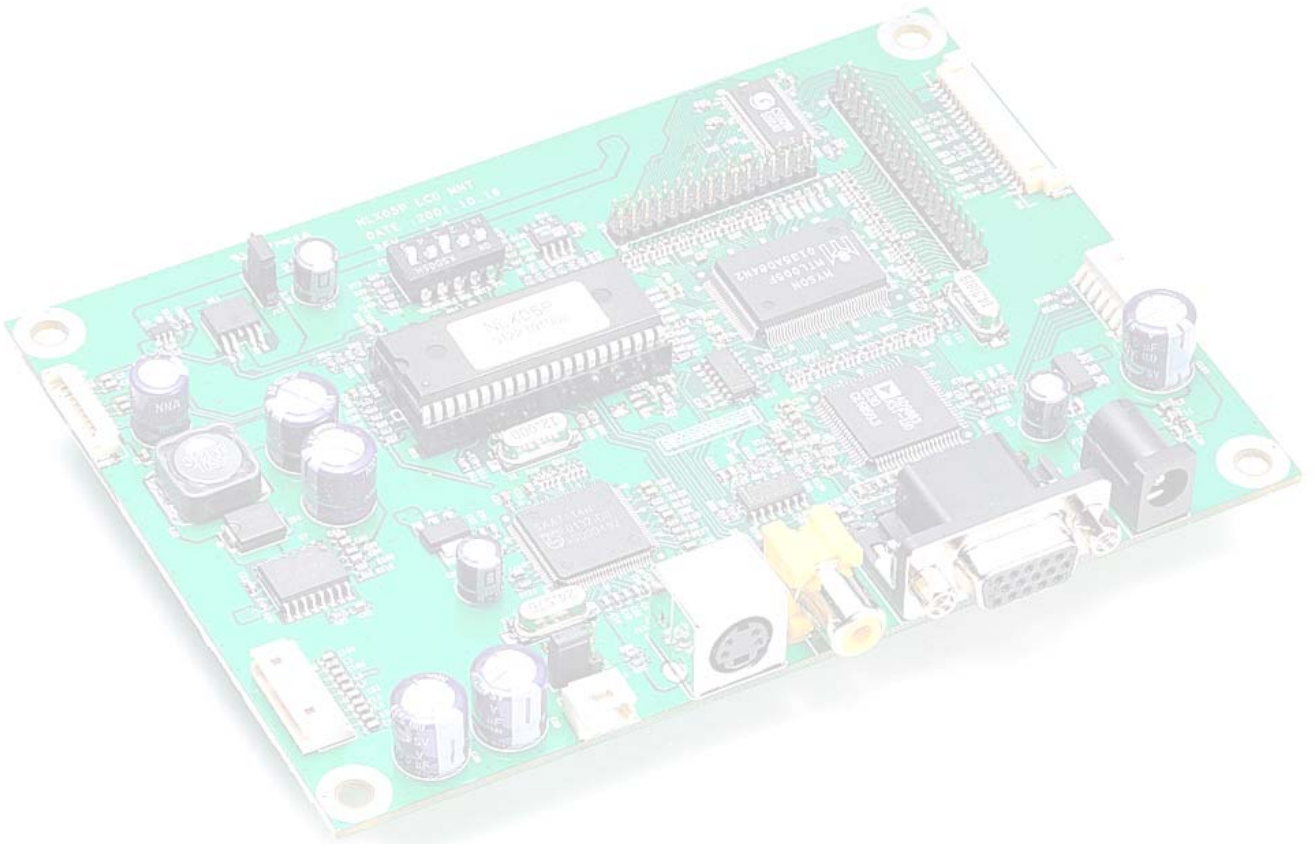

ACCESSORY

This board requires several accessories to build a complete display unit.

No.	Items	Part No.	Ex)
1	LCD signal cable	SC-Panel Part No.-mm	
2	Inverter	Part no. of Manufacturer	
3	Inverter cable	IC-Panel Part No.-mm	
4	OSD Board	NOB0005P	
5	OSD Cable	OC-NID01-mm	

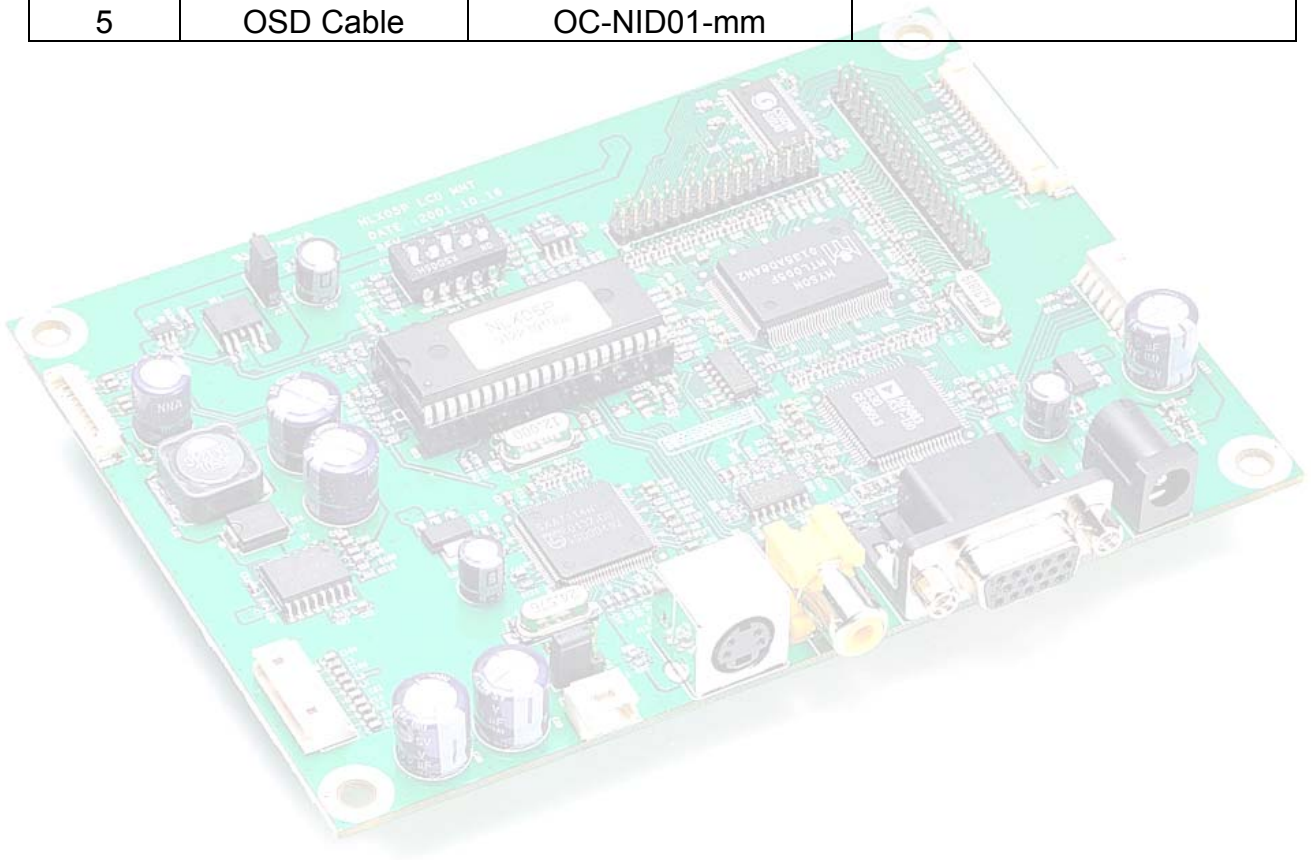

APPENDIX

A. Target panel jumper setting

LCD

1~3: Output Resolution Selection

1	2	3	Remarks
OFF	OFF	OFF	1024 X 768
ON	OFF	OFF	1280 X 768
OFF	ON	OFF	1366 X 768
ON	ON	OFF	1280 X 768
OFF	OFF	ON	1280 X 1024
ON	OFF	ON	1600 X 1200
OFF	ON	ON	1920 X 1080
ON	ON	ON	1920 X 1200

4: LVDS MAP Selection => ON Map1, OFF: Map2

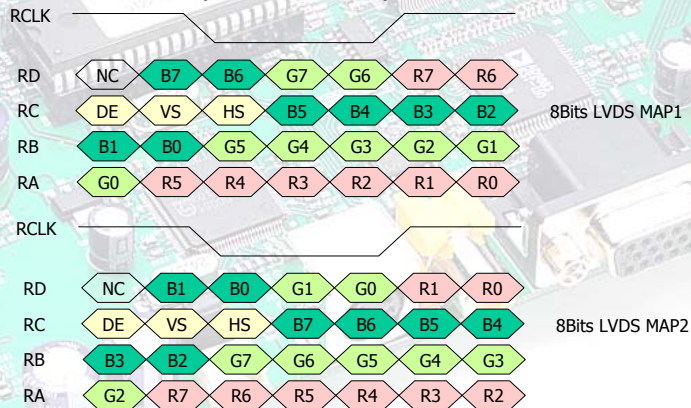

5: LCD/PDP Selection

* ON: PDP OFF: LCD

PDP

1~3: Output Resolution Selection (TBD)

1	2	3	Remarks
OFF	OFF	OFF	852 X 480
ON	OFF	OFF	1024 X 768
OFF	ON	OFF	1366 X 768

4: LVDS MAP Selection => ON Map1, OFF: Map2

5: LCD/PDP Selection

* ON: PDP OFF: LCD

A. Tested panel

This board can support various LCD panels, which have XGA, WXGA, SXGA, UXGA and WUXGA resolution.

The table below shows the model names of LCD panel, Jumper setting for LCD power, LCD panel selection and the dedicated inverter for each LCD panel. All of the LCD Panels listed can work without changing the control program of the NCB410 board.

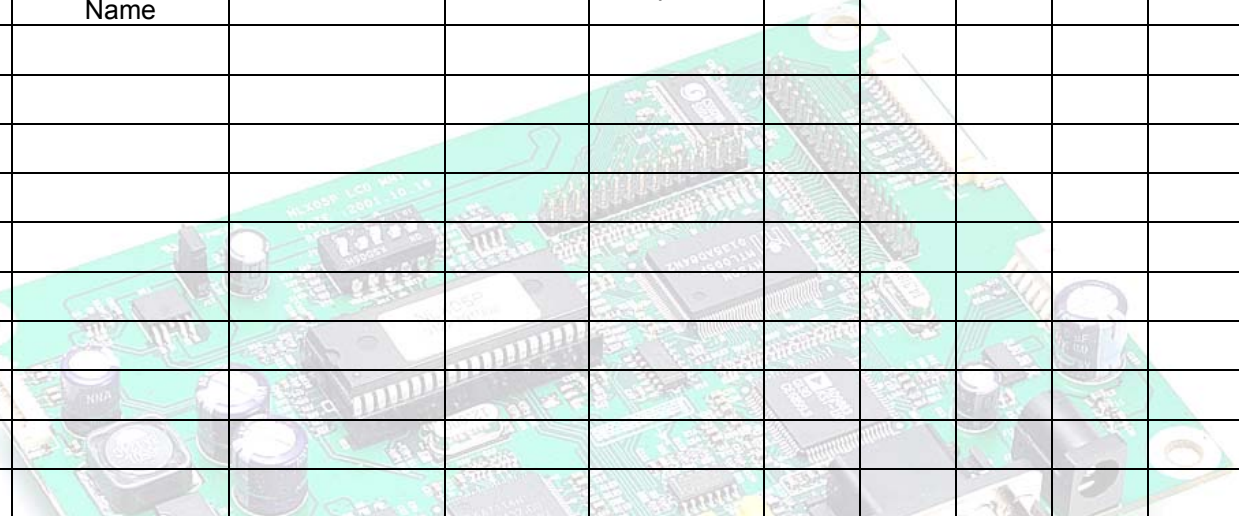

No.	LCD Model Name	LCD vendor	LCD VCC	Option	SW1	SW2	SW3	SW4	SW5
1									
2									
3									
4									
5									
6									
7									
8									
9									
10									



Data Modul Aktiengesellschaft

Landsberger-Str. 322
D-80687 München
Tel.: +49-89-56017-0
Fax: +49-89-56017-119



Data Modul Sales Office Düsseldorf

Fritz-Vomfelde-Str. 8
D-40547 Düsseldorf
Tel.: +49-211-52709-0
Fax: +49-211-52709-19



Data Modul Sales Office Stuttgart

Friedrich-List-Str. 42
D-70771 Leinfelden-Echterdingen
Tel.: +49-711-782385-0
Fax: +49-711-782385-29



Data Modul Inc.

1767-46 Veterans Memorial Highway
Islandia NY 11749 USA
Tel.: +1-631-951-0800
Fax: +1-631-951-2121



Data Modul Ltd.

3 Brindley Place
Birmingham B12JB UK
Tel.: +44 121 698 8641
Fax: +44 121 698 8623

www.data-modul.de
info@data-modul.de