

NCT6102D / NCT6106D
Nuvoton LPC I/O

Date: January 11th, 2012 Revision 1.0

Table of Contents –

1.	GENERAL DESCRIPTION.....	1
2.	FEATURES.....	2
3.	BLOCK DIAGRAM.....	5
4.	PIN LAYOUT	6
5.	PIN DESCRIPTION	8
5.1	LPC Interface	9
5.2	FDC Interface	9
5.3	Multi-Mode Parallel Port.....	11
5.4	Serial Port Interface (UART C ~ UART F are for NCT6106D only)	13
5.5	KBC Interface	16
5.6	CIR Interface	16
5.7	Hardware Monitor Interface.....	16
5.8	Intel® PECI Interface	17
5.9	Advanced Configuration & Power Interface	18
5.10	Advanced Sleep State Control Control	18
5.11	Port 80 Message Display	18
5.12	SMBus Interface.....	19
5.13	Power Pins	19
5.14	AMD SB-TSI Interface.....	19
5.15	Dual Voltage Control	20
5.16	DSW	20
5.17	WatchDog.....	20
5.18	IR.....	20
5.19	SUSPEND LED	21
5.20	General Purpose I/O Port.....	21
5.20.1	GPIO-0 Interface	21
5.20.2	GPIO-1 Interface	21
5.20.3	GPIO-2 Interface	22
5.20.4	GPIO-3 Interface	23
5.20.5	GPIO-4 Interface	24
5.20.6	GPIO-5 Interface	25
5.20.7	GPIO-6 Interface	25
5.20.8	GPIO-7 Interface	26
5.21	Strapping Pins	26
5.22	Internal pull-up, pull-down pins	27
6.	GLUE LOGIC.....	29
6.1	ACPI Glue Logic.....	29
6.2	BKFD_CUT & LATCH_BKFD_CUT	31
6.3	3VSBSW#	32
6.4	PSON# Block Diagram.....	33
6.5	PWROK.....	34
6.6	Front Panel LEDs	35
6.6.1	Automatic Mode.....	35
6.6.2	Manual Mode.....	36

6.6.3	S0~S5 LED Blink Block Diagram	36
6.6.4	LED Pole (LED_POL).....	37
6.6.5	Deeper Sleeping State Detect Function	38
6.7	Advanced Sleep State Control (ASSC) Function	40
6.7.1	When ASSC is disabled	40
6.7.2	When ASSC is enabled (Enter into Deeper Sleeping State).....	41
6.7.3	When ASSC is enabled (Exit Deeper Sleeping State)	41
6.7.4	SLP_S5#_LATCH Control Function	42
6.8	Intel DSW Function	43
6.8.1	Enter DSW State timing diagram	43
6.8.2	Exit DSW State timing diagram	44
6.8.3	Application Circuit.....	44
7.	CONFIGURATION REGISTER ACCESS PROTOCOL.....	46
7.1	Configuration Sequence.....	48
7.1.1	Enter the Extended Function Mode.....	48
7.1.2	Configure the Configuration Registers	48
7.1.3	Exit the Extended Function Mode	49
7.1.4	Software Programming Example.....	49
8.	HARDWARE MONITOR.....	50
8.1	General Description.....	50
8.2	Access Interfaces	50
8.3	LPC Interface	50
8.4	I ² C interface.....	52
8.5	Analog Inputs	53
8.5.1	Voltages Over 2.048 V or Less Than 0 V	54
8.5.2	Voltage Data Format	54
8.5.3	Temperature Data Format	55
8.6	PECI	57
8.7	Fan Speed Measurement and Control	60
8.7.1	Fan Speed Reading.....	60
8.7.2	Fan Speed Calculation by Fan Count Reading.....	60
8.7.3	Fan Speed Calculation by Fan RPM Reading	60
8.7.4	Fan Speed Control	60
8.7.5	SMART FAN TM Control.....	61
8.7.6	Temperature Source & Reading for Fan Control	62
8.8	SMART FAN TM I.....	62
8.8.1	Thermal Cruise Mode	62
8.8.2	Speed Cruise Mode.....	64
8.9	SMART FAN TM IV & Close Loop Fan Control RPM Mode	66
8.9.1	Step Up Time / Step Down Time.....	70
8.9.2	Fan Output Step	70
8.9.3	Revolution Pulse Selection.....	71
8.9.4	Weight Value Control.....	71
8.10	Alert and Interrupt.....	73

8.10.1	SMI# Interrupt Mode.....	74
8.10.2	Voltage SMI# Mode	74
8.10.3	Fan SMI# Mode	74
8.10.4	Temperature SMI# Mode.....	74
8.10.5	OVT# Interrupt Mode.....	80
8.10.6	Caseopen Detection.....	80
8.11	Power Measurement	81
9.	HARDWARE MONITOR REGISTER SET	83
9.1	Address Port (Port x5h).....	83
9.2	Data Port (Port x6h)	83
9.3	Value RAM — Index 00h ~ 6Fh (Bank 0).....	84
9.4	SMIOVT1 Temperature Source (High Byte) Register – Index 10h (Bank 0)	87
9.5	SMIOVT2 Temperature Source (High Byte) Register – Index 11h (Bank 0)	87
9.6	SMIOVT3 Temperature Source (High Byte) Register – Index 12h (Bank 0)	87
9.7	SMIOVT4 Temperature Source (High Byte) Register – Index 13h (Bank 0)	88
9.8	SMIOVT5 Temperature Source (High Byte) Register – Index 14h (Bank 0)	88
9.9	SMIOVT6 Temperature Source (High Byte) Register – Index 15h (Bank 0)	88
9.10	SMIOVT1-6 Temperature Source (Low Byte) Register – Index 16h (Bank 0).....	88
9.11	System Fan Control Temperature Register (Integer Value)- Index 18h (Bank 0)	89
9.12	Cpu Fan Control Temperature Register (Integer Value)- Index 19h (Bank 0).....	89
9.13	Aux Fan Control Temperature Register (Integer Value)- Index 1Ah (Bank 0).....	89
9.14	Fan Temperature Register (Fractional Value)- Index 1Bh (Bank 0)	90
9.15	(SYSFANIN) FANIN1 COUNT High-byte Register – Index 20h (Bank 0).....	90
9.16	(SYSFANIN) FANIN1 COUNT Low-byte Register – Index 21h (Bank 0)	90
9.17	(CPUFANIN) FANIN2 COUNT High-byte Register – Index 22h (Bank 0)	91
9.18	(CPUFANIN) FANIN2 COUNT Low-byte Register – Index 23h (Bank 0)	91
9.19	(AUXFANIN) FANIN3 COUNT High-byte Register – Index 24h (Bank 0)	91
9.20	(AUXFANIN) FANIN3 COUNT Low-byte Register – Index 25h (Bank 0)	91
9.21	Bank Select Register – Index 4Eh (Bank 0).....	92
9.22	PORT 80 DATA INPUT Register – Index 4F (Bank 0).....	92
9.23	PCH_CHIP_CPU_MAX_TEMP Register – Index 50h (Bank 0)	92
9.24	PCH_CHIP_TEMP Register – Index 51h (Bank 0)	93
9.25	PCH_CPU_TEMP_H Register – Index 52h (Bank 0)	93
9.26	PCH_CPU_TEMP_L Register – Index 53h (Bank 0)	93
9.27	PCH_MCH_TEMP Register – Index 54h (Bank 0)	93
9.28	PCH_DIM0_TEMP Register – Index 55h (Bank 0)	94
9.29	PCH_DIM1_TEMP Register – Index 56h (Bank 0)	94
9.30	PCH_DIM2_TEMP Register – Index 57h (Bank 0)	94
9.31	PCH_DIM3_TEMP Register – Index 58h (Bank 0)	95
9.32	PCH_TSI0_TEMP_H Register – Index 59h (Bank 0)	95
9.33	PCH_TSI0_TEMP_L Register – Index 5Ah (Bank 0).....	95
9.34	PCH_TSI1_TEMP_H Register – Index 5Bh (Bank 0)	95
9.35	PCH_TSI1_TEMP_L Register – Index 5Ch (Bank 0)	96
9.36	PCH_TSI2_TEMP_H Register – Index 5Dh (Bank 0).....	96
9.37	PCH_TSI2_TEMP_L Register – Index 5Eh (Bank 0).....	96

9.38	PCH_TSI3_TEMP_H Register – Index 5Fh (Bank 0)	96
9.39	PCH_TSI3_TEMP_L Register – Index 60h (Bank 0)	97
9.40	PCH_TSI4_TEMP_H Register – Index 61h (Bank 0)	97
9.41	PCH_TSI4_TEMP_L Register – Index 62h (Bank 0)	97
9.42	PCH_TSI5_TEMP_H Register – Index 63h (Bank 0)	98
9.43	PCH_TSI5_TEMP_L Register – Index 64h (Bank 0)	98
9.44	PCH_TSI6_TEMP_H Register – Index 65h (Bank 0)	98
9.45	PCH_TSI6_TEMP_L Register – Index 66h (Bank 0)	98
9.46	PCH_TSI7_TEMP_H Register – Index 67h (Bank 0)	99
9.47	PCH_TSI7_TEMP_L Register – Index 68h (Bank 0)	99
9.48	ByteTemp_H Register – Index 69h (Bank 0)	99
9.49	ByteTemp_L Register – Index 6Ah (Bank 0)	99
9.50	Peci Temp Register – Index 6Bh (Bank 0).....	100
9.51	Interrupt Status Register 1 – Index 70h (Bank 0).....	100
9.52	Interrupt Status Register 2 – Index 71h (Bank 0).....	100
9.53	Interrupt Status Register 3 – Index 72h (Bank 0).....	101
9.54	Interrupt Status Register 4 – Index 73h (Bank 0).....	102
9.55	Interrupt Status Register 5 – Index 74h (Bank 0).....	102
9.56	Interrupt Status Register 6 – Index 75h (Bank 0).....	103
9.57	Interrupt Status Register 7 – Index 76h (Bank 0).....	103
9.58	Real Time Status Register 1 – Index 77h (Bank 0).....	103
9.59	Real Time Status Register 2 – Index 78h (Bank 0).....	104
9.60	Real Time Status Register 3 – Index 79h (Bank 0).....	105
9.61	Real Time Status Register 4 – Index 7Ah (Bank 0)	105
9.62	Real Time Status Register 5 – Index 7Bh (Bank 0)	106
9.63	Real Time Status Register 6 – Index 7Ch (Bank 0)	107
9.64	Real Time Status Register 7 – Index 7Dh (Bank 0)	107
9.65	Reserved Register – Index 7Eh ~ 7Fh (Bank 0)	108
9.66	SMI# Mask Register 1 – Index 80h (Bank 0)	108
9.67	SMI# Mask Register 2 – Index 81h (Bank 0)	108
9.68	SMI# Mask Register 3 – Index 82h (Bank 0)	109
9.69	SMI# Mask Register 4 – Index 83h (Bank 0)	109
9.70	SMI# Mask Register 5 – Index 84h (Bank 0)	110
9.71	SMI# Mask Register 6 – Index 85h (Bank 0)	110
9.72	SMI# Mask Register 7 – Index 86h (Bank 0)	111
9.73	CPUVCORE High Limit Voltage Register – Index 90h (Bank 0)	111
9.74	CPUVCORE Low Limit Voltage Register – Index 91h (Bank 0)	111
9.75	VIN0 High Limit Voltage Register – Index 92h (Bank 0)	112
9.76	VIN1 Low Limit Voltage Register – Index 93h (Bank 0).....	112
9.77	AVCC High Limit Voltage Register – Index 94h (Bank 0)	112
9.78	AVCC Low Limit Voltage Register – Index 95h (Bank 0).....	112
9.79	3VCC High Limit Voltage Register – Index 96h (Bank 0)	113
9.80	3VCC Low Limit Voltage Register – Index 97h (Bank 0)	113
9.81	VIN1 High Limit Voltage Register – Index 98h (Bank 0)	113
9.82	VIN1 Low Limit Voltage Register – Index 99h (Bank 0).....	113
9.83	VIN2 High Limit Voltage Register – Index 9Ah (Bank 0).....	114

9.84	VIN2 Low Limit Voltage Register – Index 9Bh (Bank 0)	114
9.85	Reserved Register – Index 9Ch ~ 9Dh (Bank 0).....	114
9.86	3VSB High Limit Voltage Register – Index 9Eh (Bank 0)	114
9.87	3VSB Low Limit Voltage Register – Index 9Fh (Bank 0)	115
9.88	VBAT High Limit Voltage Register – Index A0h (Bank 0)	115
9.89	VBAT Low Limit Voltage Register – Index A1h (Bank 0)	115
9.90	V10 High Limit Voltage Register – Index A2h (Bank 0)	115
9.91	V10 Low Limit Voltage Register – Index A3h (Bank 0)	116
9.92	Reserved Register – Index A4h ~ AFh (Bank 0).....	116
9.93	SMIOVT1 Temperature Source Select Register – Index B0 (Bank 0).....	116
9.94	SMIOVT2 Temperature Source Select Register – Index B1 (Bank 0).....	117
9.95	SMIOVT3 Temperature Source Select Register – Index B2 (Bank 0).....	117
9.96	SMIOVT4 Temperature Source Select Register – Index B3 (Bank 0).....	118
9.97	SMIOVT5 Temperature Source Select Register – Index B4 (Bank 0).....	119
9.98	SMIOVT6 Temperature Source Select Register – Index B5 (Bank 0).....	120
9.99	SMI/OVT Control Register – Index B6h (Bank 0)	121
9.100	SMIOVT1 Control Register – Index B7h (Bank 0)	121
9.101	SMIOVT2 Control Register – Index B8h (Bank 0)	122
9.102	SMIOVT3 Control Register – Index B9h (Bank 0)	123
9.103	SMIOVT4 Control Register – Index BAh (Bank 0)	123
9.104	SMIOVT5 Control Register – Index BBh (Bank 0)	124
9.105	SMIOVT6 Control Register – Index BCh (Bank 0).....	124
9.106	Reserved Register – Index BDh ~ BFh (Bank 0)	125
9.107	SMIOVT1 Shut-down mode High Limit Temperature Register – Index C0h (Bank 0).....	125
9.108	SMIOVT1 Shut-down mode Low Limit Temperature Register – Index C1h (Bank 0)	125
9.109	SMIOVT1 Temperature Source Over-temperature (High Byte) Register – Index C2h (Bank 0) ..	126
9.110	SMIOVT1 Temperature Source Hysteresis (High Byte) Register – Index C3h (Bank 0).....	126
9.111	SMIOVT2 Shut-down mode High Limit Temperature Register – Index C4h (Bank 0).....	126
9.112	SMIOVT2 Shut-down mode Low Limit Temperature Register – Index C5h (Bank 0)	126
9.113	SMIOVT2 Temperature Source Over-temperature (High Byte) Register – Index C6h (Bank 0) ..	127
9.114	SMIOVT2 Temperature Source Hysteresis (High Byte) Register – Index C7h (Bank 0).....	127
9.115	SMIOVT3 Shut-down mode High Limit Temperature Register – Index C8h (Bank 0).....	127
9.116	SMIOVT3 Shut-down mode Low Limit Temperature Register – Index C9h (Bank 0)	128
9.117	SMIOVT3 Temperature Source Over-temperature (High Byte) Register – Index CAh (Bank 0) ..	128
9.118	SMIOVT3 Temperature Source Hysteresis (High Byte) Register – Index CBh (Bank 0)	128
9.119	SMIOVT4 Shut-down mode High Limit Temperature Register – Index CCh (Bank 0)	128
9.120	SMIOVT4 Shut-down mode Low Limit Temperature Register – Index CDh (Bank 0).....	129
9.121	SMIOVT4 Temperature Source Over-temperature (High Byte) Register – Index CEh (Bank 0) ..	129
9.122	SMIOVT4 Temperature Source Hysteresis (High Byte) Register – Index CFh (Bank 0)	129
9.123	SMIOVT5 Shut-down mode High Limit Temperature Register – Index D0h (Bank 0).....	129
9.124	SMIOVT5 Shut-down mode Low Limit Temperature Register – Index D1h (Bank 0)	130
9.125	SMIOVT5 Temperature Source Over-temperature (High Byte) Register – Index D2h (Bank 0) ..	130
9.126	SMIOVT5 Temperature Source Hysteresis (High Byte) Register – Index D3h (Bank 0).....	130
9.127	SMIOVT6 Shut-down mode High Limit Temperature Register – Index D4h (Bank 0).....	131
9.128	SMIOVT6 Shut-down mode Low Limit Temperature Register – Index D5h (Bank 0)	131
9.129	SMIOVT6 Temperature Source Over-temperature (High Byte) Register – Index D6h (Bank 0) ..	131

9.130 SMIOVT6 Temperature Source Hysteresis (High Byte) Register – Index D7h (Bank 0).....	131
9.131 Reserved Register – Index D8h ~ DFh (Bank 0)	132
9.132 (SYSFANIN) Fan Count Limit High-byte Register – Index E0h (Bank 0)	132
9.133 (SYSFANIN) Fan Count Limit Low-byte Register – Index E1h (Bank 0)	132
9.134 (CPUFANIN) Fan Count Limit High-byte Register – Index E2h (Bank 0)	132
9.135 (CPUFANIN) Fan Count Limit Low-byte Register – Index E3h (Bank 0).....	133
9.136 (AUXFANIN) Fan Count Limit High-byte Register – Index E4h (Bank 0)	133
9.137 (AUXFANIN) Fan Count Limit Low-byte Register – Index E5h (Bank 0)	133
9.138 Reserved Register – Index E6h ~ EFh (Bank 0).....	133
9.139 SYSFAN PWM Output Frequency Configuration Register – Index F0h (Bank 0)	133
9.140 CPUFAN PWM Output Frequency Configuration Register – Index F1h (Bank 0).....	134
9.141 AUXFAN PWM Output Frequency Configuration Register – Index F2h (Bank 0)	134
9.142 FAN Output Mode Configuration – Index F3h (Bank 0).....	135
9.143 Reserved Register – Index F4h ~ F5h (Bank 0)	136
9.144 FANIN Revolution Pulses Selection Register – Index F6h (Bank 0)	136
9.145 Serial Bus Address Register – Index F7h (Bank 0)	136
9.146 FAN IN/OUT Control Register – Index F8h (Bank 0).....	137
9.147 Reserved Register – Index F9h ~ FCh (Bank 0).....	137
9.148 Nuvoton Vendor ID Register by I2C Interface – Index FDh (Bank 0)	137
9.149 Nuvoton Vendor ID Register by LPC Interface – Index FEh (Bank 0).....	138
9.150 Chip ID – Index FFh (Bank 0)	138
9.151 SYSFAN Monitor Temperature Source Select Register/ STOPDUTY Enable Register – Index 10h (Bank 1)	138
9.152 SYSFAN Target Temperature Register / SYSFANIN Target Speed_L Register – Index 11h (Bank 1).....	139
9.153 SYSFANIN Tolerance_H / Target Speed_H Register – Index 12h (Bank 1).....	140
9.154 SYSFAN MODE Register / SYSFAN TOLERRANCE Register – Index 13h (Bank 1)	140
9.155 SYSFAN Step Up Time Register – Index 14h (Bank 1).....	140
9.156 SYSFAN Step Down Time Register – Index 15h (Bank 1)	141
9.157 SYSFAN Stop Value Register – Index 16h (Bank 1)	141
9.158 SYSFAN Start-up Value Register – Index 17h (Bank 1).....	141
9.159 SYSFAN Stop Time Register – Index 18h (Bank 1)	141
9.160 SYSFAN Output Value Select Register – Index 19h (Bank 1).....	142
9.161 SYSFAN Temperature Critical Register – Index 1Ah (Bank 1).....	142
9.162 SYSFAN Critical Temperature Tolerance Register – Index 1Bh (Bank 1).....	142
9.163 SYSFAN Enable Critical Duty / Fanout Step Register – Index 1Ch (Bank 1).....	143
9.164 SYSFAN Critical Duty Register – Index 1Dh (Bank 1).....	143
9.165 SYSFAN Enable Close Loop Fan Control RPM Mode Register – Index 1Eh (Bank 1).....	143
9.166 SYSFAN Enable RPM High Mode / RPM Mode Tolerance Register – Index 1Fh (Bank 1).....	144
9.167 CPUFAN Monitor Temperature Source Select Register/ STOPDUTY Enable Register – Index 20h (Bank 1)	144
9.168 CPUFAN Target Temperature Register / CPUFANIN Target Speed_L Register – Index 21h (Bank 1).....	145
9.169 CPUFANIN Tolerance_H / Target Speed_H Register – Index 22h (Bank 1).....	145
9.170 CPUFAN MODE Register / CPUFAN TOLERRANCE Register – Index 23h (Bank 1)	146
9.171 CPUFAN Step Up Time Register – Index 24h (Bank 1)	146
9.172 CPUFAN Step Down Time Register – Index 25h (Bank 1).....	146

9.173 CPUFAN Stop Value Register – Index 26h (Bank 1).....	147
9.174 CPUFANOUT Start-up Value Register – Index 27h (Bank 1).....	147
9.175 CPUFAN Stop Time Register – Index 28h (Bank 1).....	147
9.176 CPUFANOUT Output Value Select Register – Index 29h (Bank 1).....	148
9.177 CPUFAN Temperature Critical Register – Index 2Ah (Bank 1).....	148
9.178 CPUFAN Critical Temperature Tolerance Register – Index 2Bh (Bank 1).....	148
9.179 CPUFAN Enable Critical Duty / Fanout Step Register – Index 2Ch (Bank 1).....	148
9.180 CPUFAN Critical Duty Register – Index 2Dh (Bank 1).....	149
9.181 CPUFAN Enable Close Loop Fan Control RPM Mode Register – Index 2Eh (Bank 1).....	149
9.182 CPUFAN Enable RPM High Mode / RPM Mode Tolerance Register – Index 2Fh (Bank 1).....	150
9.183 AUXFAN Monitor Temperature Source Select Register/ STOPDUTY Enable Register – Index 30h (Bank 1).....	150
9.184 AUXFAN Target Temperature Register / AUXFANIN Target Speed_L Register – Index 31h (Bank 1).....	151
9.185 AUXFANIN Tolerance_H / Target Speed_H Register – Index 32h (Bank 1).....	151
9.186 AUXFAN MODE Register / AUXFAN TOLERRANCE Register – Index 33h (Bank 1).....	152
9.187 AUXFAN Step Up Time Register – Index 34h (Bank 1).....	152
9.188 AUXFAN Step Down Time Register – Index 35h (Bank 1).....	152
9.189 AUXFAN Stop Value Register – Index 36h (Bank 1).....	153
9.190 AUXFAN Start-up Value Register – Index 37h (Bank 1).....	153
9.191 AUXFAN Stop Time Register – Index 38h (Bank 1).....	153
9.192 AUXFAN Output Value Select Register – Index 39h (Bank 1).....	153
9.193 AUXFAN Temperature Critical Register – Index 3Ah (Bank 1).....	154
9.194 AUXFAN Critical Temperature Tolerance Register – Index 3Bh (Bank 1).....	154
9.195 AUXFAN Enable Critical Duty / Fanout Step Register – Index 3Ch (Bank 1).....	154
9.196 AUXFAN Critical Duty Register – Index 3Dh (Bank 1).....	155
9.197 AUXFAN Enable Close Loop Fan Control RPM Mode Register – Index 3Eh (Bank 1).....	155
9.198 AUXFAN Enable RPM High Mode / RPM Mode Tolerance Register – Index 3Fh (Bank 1).....	155
9.199 SYSFAN (SMART FAN™ IV) Temperature 1 Register(T1) – Index 60h (Bank 1).....	156
9.200 SYSFAN (SMART FAN™ IV) Temperature 2 Register(T2) – Index 61h (Bank 1).....	156
9.201 SYSFAN (SMART FAN™ IV) Temperature 3 Register(T3) – Index 62h (Bank 1).....	156
9.202 SYSFAN (SMART FAN™ IV) Temperature 4 Register(T4) – Index 63h (Bank 1).....	157
9.203 SYSFAN (SMART FAN™ IV) FD1/RPM1 Register – Index 64h (Bank 1).....	157
9.204 SYSFAN (SMART FAN™ IV) FD2/RPM2 Register – Index 65h (Bank 1).....	157
9.205 SYSFAN (SMART FAN™ IV) FD3/RPM3 Register – Index 66h (Bank 1).....	157
9.206 SYSFAN (SMART FAN™ IV) FD4/RPM4 Register – Index 67h (Bank 1).....	158
9.207 SYSFAN Weight value Configuration Register – Index 68h (Bank 1).....	158
9.208 SYSFAN Weight Temperature Step Register – Index 69h (Bank 1).....	159
9.209 SYSFAN Weight Temperature Step Tolerance Register – Index 6Ah (Bank 1).....	159
9.210 SYSFAN Weight Step Register – Index 6Bh (Bank 1).....	159
9.211 SYSFAN Weight Temperature Base Register – Index 6Ch (Bank 1).....	160
9.212 SYSFAN Weight Fan Duty Base Register – index 6Dh (Bank 1).....	160
9.213 SYSFAN Enable PECCIERR DUTY Register – Index 6Eh (Bank 1).....	160
9.214 SYSFAN Pre-Configured Register For PECCI Error – Index 6Fh (Bank 1).....	160
9.215 CPUFAN (SMART FAN™ IV) Temperature 1 Register(T1) – Index 70h (Bank 1).....	161
9.216 CPUFAN (SMART FAN™ IV) Temperature 2 Register(T2) – Index 71h (Bank 1).....	161

9.217 CPUFAN (SMART FAN™ IV) Temperature 3 Register(T3) – Index 72h (Bank 1).....	161
9.218 CPUFAN (SMART FAN™ IV) Temperature 4 Register(T4) – Index 73h (Bank 1).....	162
9.219 CPUFAN (SMART FAN™ IV) FD1/RPM1 Register – Index 74h (Bank 1).....	162
9.220 CPUFAN (SMART FAN™ IV) FD2/RPM2 Register – Index 75h (Bank 1).....	162
9.221 CPUFAN (SMART FAN™ IV) FD3/RPM3 Register – Index 76h (Bank 1).....	162
9.222 CPUFAN (SMART FAN™ IV) FD4/RPM4 Register – Index 77h (Bank 1).....	163
9.223 CPUFAN Weight value Configuration Register – Index 78h (Bank 1).....	163
9.224 CPUFAN Weight Temperature Step Register – Index 79h (Bank 1).....	164
9.225 CPUFAN Weight Temperature Step Tolerance Register – Index 7Ah (Bank 1).....	164
9.226 CPUFAN Weight Step Register – Index 7Bh (Bank 1).....	164
9.227 CPUFAN Weight Temperature Base Register – Index 7Ch (Bank 1).....	165
9.228 CPUFAN Weight Fan Duty Base Register – Index 7Dh (Bank 1).....	165
9.229 CPUFAN Enable PECCIERR DUTY Register – Index 7Eh (Bank 1).....	165
9.230 CPUFAN Pre-Configured Register For PECCI Error – Index 7Fh (Bank 1).....	165
9.231 AUXFAN (SMART FAN™ IV) Temperature 1 Register(T1) – Index 80h (Bank 1).....	166
9.232 AUXFAN (SMART FAN™ IV) Temperature 2 Register(T2) – Index 81h (Bank 1).....	166
9.233 AUXFAN (SMART FAN™ IV) Temperature 3 Register(T3) – Index 82h (Bank 1).....	166
9.234 AUXFAN (SMART FAN™ IV) Temperature 4 Register(T4) – Index 83h (Bank 1).....	166
9.235 AUXFAN (SMART FAN™ IV) FD1/RPM1 Register – Index 84h (Bank 1).....	167
9.236 AUXFAN (SMART FAN™ IV) FD2/RPM2 Register – Index 85h (Bank 1).....	167
9.237 AUXFAN (SMART FAN™ IV) FD3/RPM3 Register – Index 86h (Bank 1).....	167
9.238 AUXFAN (SMART FAN™ IV) FD4/RPM4 Register – Index 87h (Bank 1).....	167
9.239 AUXFAN Weight value Configuration Register – Index 88h (Bank 1).....	168
9.240 AUXFAN Weight Temperature Step Register – Index 89h (Bank 1).....	169
9.241 AUXFAN Weight Temperature Step Tolerance Register – Index 8Ah (Bank 1).....	169
9.242 AUXFAN Weight Step Register – Index 8Bh (Bank 1).....	169
9.243 AUXFAN Weight Temperature Base Register – Index 8Ch (Bank 1).....	169
9.244 AUXFAN Weight Fan Duty Base Register – Index 8Dh (Bank 1).....	170
9.245 AUXFAN Enable PECCIERR DUTY Register – Index 8Eh (Bank 1).....	170
9.246 AUXFAN Pre-Configured Register For PECCI Error – Index 8Fh (Bank 1).....	170
9.247 Reserved Register – Index 90h~FF (Bank 1).....	171
9.248 PECCI Function Control Registers – Index 00 ~ 03h (Bank 2).....	171
9.249 PECCI Enable Function Register – Index 00h (Bank 2).....	171
9.250 PECCI Timing Config Register – Index 01h (Bank 2).....	171
9.251 PECCI Agent Config Register – Index 02h (Bank 2).....	172
9.252 PECCI Temperature Config Register – Index 03h (Bank 2).....	172
9.253 PECCI Command Tbase0 Register – Index 04h (Bank 2).....	173
9.254 PECCI Command Tbase1 Register – Index 05h (Bank 2).....	173
9.255 PECCI Agent Relative Temperature Register – Index 06h-0Dh (Bank 2).....	173
9.256 PECCI Command Write Date Registers – Index 10 ~ 1Fh (Bank 2).....	175
9.257 PECCI Command Address Register – Index 10h (Bank 2).....	175
9.258 PECCI Command Write Length Register – Index 11h (Bank 2).....	175
9.259 PECCI Command Read Length Register – Index 12h (Bank 2).....	175
9.260 PECCI Command Code Register – Index 13h (Bank 2).....	175
9.261 PECCI Command Write Data 1 Register – Index 14h (Bank 2).....	176
9.262 PECCI Command Write Data 2 Register – Index 15h (Bank 2).....	176

9.263	PECI Command Write Data 3 Register – Index 16h (Bank 2)	176
9.264	PECI Command Write Data 4 Register – Index 17h (Bank 2)	177
9.265	PECI Command Write Data 5 Register – Index 18h (Bank 2)	177
9.266	PECI Command Write Data 6 Register – Index 19h (Bank 2)	177
9.267	PECI Command Write Data 7 Register – Index 1Ah (Bank 2)	177
9.268	PECI Command Write Data 8 Register – Index 1Bh (Bank 2)	178
9.269	PECI Command Write Data 9 Register – Index 1Ch (Bank 2)	178
9.270	PECI Command Write Data 10 Register – Index 1Dh (Bank 2)	178
9.271	PECI Command Write Data 11 Register – Index 1Eh (Bank 2)	179
9.272	PECI Command Write Data 12 Register – Index 1Fh (Bank 2)	179
9.273	PECI Command Read Date Registers – Index 20 ~ 24h (Bank 2)	179
9.274	PECI Absolute Temperature value Register – Index 20h-21h (Bank 2)	179
9.275	PECI Absolute Temperature value Register – Index 20h (Bank 2)	179
9.276	PECI Absolute Temperature value Register – Index 21h (Bank 2)	180
9.277	PECI Command Alive Agent and Warning Flag Register – Index 24h (Bank 2)	180
9.278	PECI Command Read Data Register – Index 30 ~ 38h (Bank 2)	181
9.279	PECI Command Read Data 1 Register – Index 30h (Bank 2)	181
9.280	PECI Command Read Data 2 Register – Index 31h (Bank 2)	181
9.281	PECI Command Read Data 3 Register – Index 32h (Bank 2)	181
9.282	PECI Command Read Data 4 Register – Index 33h (Bank 2)	181
9.283	PECI Command Read Data 5 Register – Index 34h (Bank 2)	182
9.284	PECI Command Read Data 6 Register – Index 35h (Bank 2)	182
9.285	PECI Command Read Data 7 Register – Index 36h (Bank 2)	182
9.286	PECI Command Read Data 8 Register – Index 37h (Bank 2)	183
9.287	PECI Command Read Data 9 Register – Index 38h (Bank 2)	183
9.288	Voltage and Temperature Read Register – Index 00h~0Fh (Bank 3)	186
9.289	SYSTIN Temperature Sensor Offset Register – Index 11h (Bank 3)	186
9.290	CPUTIN Temperature Sensor Offset Register – Index 12h (Bank 3)	186
9.291	AUXTIN Temperature Sensor Offset Register – Index 13h (Bank 3)	187
9.292	Reserved Register – Index 14h ~ 16h (Bank 3)	187
9.293	Configuration Register – Index 17h (Bank 3)	187
9.294	VBAT Monitor Control Register – Index 18h (Bank 3)	188
9.295	Current Mode Enable Register – Index 19h (Bank 3)	188
9.296	Reserved Register – Index 1Ah ~ 8Fh (Bank 3)	189
9.297	PECI Agent Enable Register – Index 90h (Bank 3)	189
9.298	Reserved Register – Index 91h ~ CFh (Bank 3)	189
9.299	Is<8:1> Current Register – Index D0h (Bank 3)	189
9.300	Is<0> Current Register – Index D1h (Bank 3)	189
9.301	POWER <9:2> Register – Index D2h (Bank 3)	190
9.302	POWER<1:0> Register – Index D3h (Bank 3)	190
9.303	VIN Register – Index D4h (Bank 3)	190
9.304	Rreg Setting Register – Index D5h (Bank 3)	191
9.305	Reg_Ratio_K and POWER_Voltage Enable Register – Index D6h (Bank 3)	191
9.306	POWER_V Register – Index D7h (Bank 3)	191
9.307	Reserved Register Index D8~FF (Bank3)	191
10.	FLOPPY DISK CONTROLLER	192

10.1	FDC Functional Description	192
10.1.1	FIFO (Data)	192
10.1.2	Data Separator	193
10.1.3	Write Precompensation	193
10.1.4	Perpendicular Recording Mode	193
10.1.5	FDC Core	193
10.1.6	FDC Commands	194
10.2	Register Descriptions	202
10.2.1	Status Register A (SA Register) (Read base address + 0)	202
10.2.2	Status Register B (SB Register) (Read base address + 1)	203
10.2.3	Digital Output Register (DO Register) (Write base address + 2)	204
10.2.4	Tape Drive Register (TD Register) (Read base address + 3)	204
10.2.5	Main Status Register (MS Register) (Read base address + 4)	205
10.2.6	Data Rate Register (DR Register) (Write base address + 4)	206
10.2.7	FIFO Register (R/W base address + 5)	207
10.2.8	Digital Input Register (DI Register) (Read base address + 7)	210
10.2.9	Configuration Control Register (CC Register) (Write base address + 7)	211
11.	UART PORT	212
11.1	UART Control Register (UCR) (Read/Write)	212
11.2	UART Status Register (USR) (Read/Write)	214
11.3	Handshake Control Register (HCR) (Read/Write)	214
11.4	Handshake Status Register (HSR) (Read/Write)	215
11.5	UART FIFO Control Register (UFR) (Write only)	216
11.6	Interrupt Status Register (ISR) (Read only)	216
11.7	Interrupt Control Register (ICR) (Read/Write)	217
11.8	Programmable Baud Generator (BLL/BHL) (Read/Write)	218
11.9	User-defined Register (UDR) (Read/Write)	219
11.10	Extending FIFO	219
11.11	UART RS485 Auto Flow Control	219
11.12	UART 9BIT-MODE	220
11.12.1	Function Description	220
11.12.2	Function Block	223
12.	PARALLEL PORT	225
12.1	Printer Interface Logic	225
12.2	Enhanced Parallel Port (EPP)	226
12.2.1	Data Port (Data Swapper)	226
12.2.2	Printer Status Buffer	227
12.2.3	Printer Control Latch and Printer Control Swapper	227
12.2.4	EPP Address Port	228
12.2.5	EPP Data Port 0-3	228
12.2.6	EPP Pin Descriptions	228
12.2.7	EPP Operation	229
12.2.8	EPP Version 1.9 Operation	229
12.2.9	EPP Version 1.7 Operation	229
12.3	Extended Capabilities Parallel (ECP) Port	229

12.3.1	ECP Register and Bit Map	230
12.3.2	Data and ecpAFifo Port	231
12.3.3	Device Status Register (DSR)	231
12.3.4	Device Control Register (DCR)	231
12.3.5	CFIFO (Parallel Port Data FIFO) Mode = 010	232
12.3.6	ECPDFIFO (ECP Data FIFO) Mode = 011	232
12.3.7	TFIFO (Test FIFO Mode) Mode = 110	232
12.3.8	CNFGA (Configuration Register A) Mode = 111	232
12.3.9	CNFGB (Configuration Register B) Mode = 111	232
12.3.10	ECR (Extended Control Register) Mode = all	233
12.3.11	ECP Pin Descriptions	234
12.3.12	ECP Operation	235
12.3.13	FIFO Operation.....	236
12.3.14	DMA Transfers	236
12.3.15	Programmed I/O (NON-DMA) Mode	236
13.	KEYBOARD CONTROLLER	237
13.1	Output Buffer	237
13.2	Input Buffer.....	237
13.3	Status Register	238
13.4	Commands	239
13.5	Hardware GATEA20/Keyboard Reset Control Logic	241
13.5.1	KB Control Register (Logic Device 5, CR-F0)	241
13.5.2	Port 92 Control Register (Default Value = 0x24)	242
14.	CONSUMER INFRARED REMOTE (CIR)	243
14.1	CIR Register Table.....	243
14.1.1	IR Configuration Register – Base Address + 0	243
14.1.2	IR Status Register – Base Address + 1	244
14.1.3	IR Interrupt Configuration Register – Base Address + 2	244
14.1.4	RX FIFO Count– Base Address + 5	245
14.1.5	IR TX Carrier Prescaler Configuration Register (CP) – Base Address + 4	245
14.1.6	IR TX Carrier Period Configuration Register (CC) – Base Address + 5.....	246
14.1.7	IR RX Sample Limited Count High Byte Register (RCLCH) – Base Address + 6.....	246
14.1.8	IR RX Sample Limited Count Low Byte Register (RCLCL) – Base Address + 7	246
14.1.9	IR FIFO Configuration Register (FIFOCON) – Base Address + 8	247
14.1.10	IR Sample RX FIFO Status Register – Base Address + 9	247
14.1.11	IR Sample RX FIFO Register – Base Address + A	248
14.1.12	TX FIFO Count– Base Address + 5	248
14.1.13	IR Sample TX FIFO Register – Base Address + C	248
14.1.14	IR Carrier Count High Byte Register – Base Address + D	249
14.1.15	IR Carrier Count Low Byte Register – Base Address + E	249
14.1.16	IR FSM Status Register (IRFSM) – Base Address + F	250
14.1.17	IR Minimum Length Register – Base Address + F	250
15.	CONSUMER INFRARED REMOTE (CIR) WAKE-UP	251
15.1	CIR WAKE-UP Register Table	251

15.1.1	IR Configuration Register – Base Address + 0	251
15.1.2	IR Status Register – Base Address + 1	252
15.1.3	IR Interrupt Configuration Register – Base Address + 2	252
15.1.4	IR TX Configuration Register – Base Address + 3	253
15.1.5	IR FIFO Compare Tolerance Configuration Register – Base Address + 4	253
15.1.6	RX FIFO Count– Base Address + 5	253
15.1.7	IR RX Sample Limited Count High Byte Register (RCLCH) – Base Address + 6	254
15.1.8	IR RX Sample Limited Count Low Byte Register (RCLCL) – Base Address + 7	254
15.1.9	IR FIFO Configuration Register (FIFOCON) – Base Address + 8	254
15.1.10	IR Sample RX FIFO Status Register – Base Address + 9	255
15.1.11	IR Sample RX FIFO Register – Base Address + A	255
15.1.12	Write FIFO – Base Address + B	255
15.1.13	Read FIFO Only – Base Address + C	256
15.1.14	Read FIFO Index – Base Address + D	256
15.1.15	Reserved – Base Address + E	256
15.1.16	IR FSM Status Register (IRFSM) – Base Address + F	256
15.1.17	IR Minimum Length Register – Base Address + F	256
16.	POWER MANAGEMENT EVENT	258
16.1	Power Control Logic	258
16.1.1	PSOEN# Logic	259
16.1.2	AC Power Failure Resume	259
16.2	Wake Up the System by Keyboard and Mouse	261
16.2.1	Waken up by Keyboard events	261
16.2.2	Waken up by Mouse events	261
16.3	Resume Reset Logic	262
17.	SERIALIZED IRQ	263
17.1	Start Frame	263
17.2	IRQ/Data Frame	264
17.3	Stop Frame	265
18.	WATCHDOG TIMER	266
19.	GENERAL PURPOSE I/O	267
19.1	GPIO ARCHITECTURE	267
19.2	ACCESS CHANNELS	272
20.	SMBUS MASTER INTERFACE	273
20.1	General Description	273
20.2	Introduction to the SMBus Master	273
20.2.1	Data Transfer Format	273
20.2.2	Arbitration	273
20.2.3	Clock Synchronization	274
20.3	SB-TSI	275
20.3.1	SB-TSI Address	275
20.4	PCH	275
20.4.1	Command Summary	275
20.5	SMBus Master	276

20.5.1	Block Diagram	276
20.5.2	Programming Flow	277
20.5.3	TSI Routine.....	277
20.5.4	PCH Routine.....	278
20.5.5	BYTE Rutine.....	278
20.5.6	Manual Mode interface.....	279
20.6	Register Type Abbreviations	279
20.6.1	Enter the Extended Function Mode.....	280
20.6.2	Configure the Configuration Registers	280
20.7	SMBus Master Register Set.....	280
20.7.1	SMBus Register Map.....	280
20.7.2	SMBus Data (SMDATA) – Bank 0.....	281
20.7.3	SMBus Write Data Size (SMWRSIZE) – Bank 0.....	281
20.7.4	SMBus Command (SMCMD) – Bank 0.....	281
20.7.5	SMBus INDEX (SMIDX) – Bank 0.....	282
20.7.6	SMBus Control (SMCTL) – Bank 0	282
20.7.7	SMBus Address (SMADDR) – Bank 0	283
20.7.8	SCL FREQ (SCLFREQ) – Bank 0.....	283
20.7.9	PCH Address (PCHADDR) – Bank 0	284
20.7.10	SMBus Error Status (Error_status) – Bank 0	284
20.7.11	PCH Command (PCHCMD) – Bank 0.....	285
20.7.12	TSI Agent Enable Register (TSI_AGENT) – Bank.....	285
20.7.13	SMBus Control 3 Register (SMCTL3) – Bank 0.....	286
20.7.14	SMBus Control 2 Register (SMCTL2) – Bank 0.....	286
20.7.15	BYTE ADDRESS (BYTE ADDR) – Bank 0	287
20.7.16	BYTE INDEX_H (BYTE_IDX_H) – Bank 0.....	287
20.7.17	BYTE INDEX_L (BYTE_IDX_L) – Bank 0.....	288
21.	FADDING LED.....	289
21.1	FADDING LED DESCRIPTION	289
21.2	MODULE OPERATION.....	289
21.3	EXAMPLE ILLUSTRATION	291
22.	PORT80 TO UART	293
23.	CONFIGURATION REGISTER	294
23.1	Chip (Global) Control Register	294
23.2	Logical Device 0 (FDC)	311
23.3	Logical Device 1 (PRT)	315
23.4	Logical Device 2 (UARTA)	317
23.5	Logical Device 3 (UARTB)	322
23.6	Logical Device 5 (KBC)	327
23.7	Logical Device 6 (CIR)	329
23.8	Logical Device 7 (GPIO)	332
23.9	Logical Device 8 (GPIO, WDT1)	343
23.10	Logical Device 9 (GPIO)	350
23.11	Logical Device A (ACPI).....	352
23.12	Logical Device B (HM, LED)	362

23.13	Logical Device D (WDT2).....	368
23.14	Logical Device E (CIR WAKE-UP).....	370
23.15	Logical Device F (GPIO).....	372
23.16	Logical Device 10 (UARTC).....	376
23.17	Logical Device 11 (UARTD).....	381
23.18	Logical Device 12 (UARTE).....	386
23.19	Logical Device 13 (UARTF).....	391
23.20	Logical Device 14 (PORT80, IR).....	396
23.21	Logical Device 15 (FADING LED).....	400
23.22	Logical Device 16 (DEEP SLEEP).....	404
24.	SPECIFICATIONS.....	406
24.1	Absolute Maximum Ratings.....	406
24.2	DC CHARACTERISTICS.....	406
25.	AC CHARACTERISTICS.....	409
25.1	Power On / Off Timing.....	409
25.2	AC Power Failure Resume Timing.....	410
25.3	Clock Input Timing.....	413
25.4	PECI Timing.....	414
25.5	SMBus Timing.....	414
25.6	Floppy Disk Drive Timing.....	415
25.7	UART/Parallel Port.....	417
25.8	Modem Control Timing.....	418
25.9	Parallel Port Mode Parameters.....	418
25.9.1	Parallel Port Timing.....	419
25.9.2	EPP Data or Address Read Cycle Timing Parameters.....	420
25.9.3	EPP Data or Address Read Cycle (EPP Version 1.9).....	421
25.9.4	EPP Data or Address Read Cycle (EPP Version 1.7).....	422
25.9.5	EPP Data or Address Write Cycle Timing Parameters.....	423
25.9.6	EPP Data or Address Write Cycle (EPP Version 1.9).....	424
25.9.7	EPP Data or Address Write Cycle (EPP Version 1.7).....	424
25.9.8	Parallel Port FIFO Timing Parameters.....	425
25.9.9	Parallel FIFO Timing.....	425
25.9.10	ECP Parallel Port Forward Timing Parameters.....	425
25.9.11	ECP Parallel Port Forward Timing.....	426
25.9.12	ECP Parallel Port Reverse Timing Parameters.....	426
25.9.13	ECP Parallel Port Reverse Timing.....	427
25.9.14	KBC Timing Parameters.....	427
25.9.15	Writing Cycle Timing.....	428
25.9.16	Read Cycle Timing.....	429
25.9.17	Send Data to K/B.....	429
25.9.18	Receive Data from K/B.....	429
25.9.19	Input Clock.....	430
25.9.20	Send Data to Mouse.....	430
25.9.21	Receive Data from Mouse.....	430
25.10	GPIO Timing Parameters.....	431



25.10.1	GPIO Write Timing	431
26.	TOP MARKING SPECIFICATIONS	432
27.	ORDERING INFORMATION	433
28.	PACKAGE SPECIFICATION.....	434
29.	REVISION HISTORY	435

LIST OF FIGURE

Figure 3-1 NCT6102D / NCT6106D Block Diagram.....	5
Figure 4-1 NCT6102D Pin Layout	6
Figure 4-2 NCT6106D Pin Layout	7
Figure 6-1 RSMRST#	29
Figure 6-2 PWROK.....	29
Figure 6-3 BKFD_CUT and LATCH_BKFD_CUT	31
Figure 6-4 3VSBSW#	32
Figure 6-5 PSON#	33
Figure 6-6 PWROK Block Diagram	34
Figure 6-7 Illustration of Dual Color LED application	35
Figure 6-8 Illustration of LED polarity	37
Figure 6-9 ASSC Application Diagram	40
Figure 7-1 Structure of the Configuration Register.....	46
Figure 7-2 Configuration Register	48
Figure 8-1 LPC Bus' Reads from / Write to Internal Registers.....	51
Figure 8-2 Serial Bus Write to Internal Address Register Followed by the Data Byte	52
Figure 8-3 Serial Bus Read from Internal Address Register	52
Figure 8-4 Analog Inputs and Application Circuit of the NCT6102D / NCT6106D	53
Figure 8-5 Monitoring Temperature from Thermistor	55
Figure 8-6 Monitoring Temperature from Thermal Diode (Voltage Mode)	56
Figure 8-7 Monitoring Temperature from Thermal Diode (Current Mode)	56
Figure 8-8 PECl Temperature	58
Figure 8-9 Temperature and Fan Speed Relation after Tbase Offsets.....	59
Figure 8-10 Thermal Cruise™ Mode Parameters Figure	63
Figure 8-11 Mechanism of Thermal Cruise™ Mode (PWN Duty Cycle)	63
Figure 8-12 Mechanism of Thermal Cruise™ Mode (DC Output Voltage)	64
Figure 8-13 Mechanism of Fan Speed Cruise™ Mode	64
Figure 8-14 SMART FAN™ IV & Close Loop Fan Control Mechanism.....	67
Figure 8-15 Fan Control Duty Mode Programming Flow.....	69
Figure 8-16 Close-Loop Fan Control RPM Mode Programming Flow	70
Figure 8-17 CPUFAN SMART FAN™ IV Table Parameters Figure.....	71
Figure 8-18 Fanout Step Relation of CPUFANOUT	71
Figure 8-19 SYS TEMP and Weight Value Relations	72
Figure 8-20 Weighting Duty Mode Programming Flow	73
Figure 8-21 SMI Mode of Voltage and Fan Inputs	74
Figure 8-22 Shut-down Interrupt Mode.....	75
Figure 8-23 SMI Mode of SYSTIN I	76
Figure 8-24 SMI Mode of SYSTIN II.....	76
Figure 8-25 Shut-down Interrupt Mode.....	77
Figure 8-26 SMI Mode of CPUTIN	77
Figure 8-27 OVT# Modes of Temperature Inputs	80
Figure 8-28 Caseopen Mechanism	81
Figure 8-29 Power measurement architecture	81

Figure 13-1 Keyboard and Mouse Interface	237
Figure 16-1 Power Control Mechanism	258
Figure 16-2 Power Sequence from S5 to S0, then Back to S5	259
Figure 16-3 The previous state is “on”	260
Figure 16-4 The previous state is “off”	260
Figure 16-5 Mechanism of Resume Reset Logic	262
Figure 17-1 Start Frame Timing with Source Sampled A Low Pulse on IRQ1	263
Figure 17-2 Stop Frame Timing with Host Using 17 SERIRQ Sampling Period	265
Figure 20-1 Data Transfer Format	273
Figure 20-2 SMBus Arbitration	274
Figure 20-3 Clock synchronization	274
Figure 20-4 SMBus Master Block Diagram	276
Figure 20-5 Programming Flow	277
Figure 20-6 TSI Routine	277
Figure 20-7 PCH Routine	278
Figure 20-8 PCH Routine	278
Figure 20-9 Manual Mode Programming Flow	279
Figure 21-1 Example of Fading LED	289
Figure 22-1 PORT80 to UART Block Diagram	293

LIST OF TABLE

Table 6-1 Pin Description	29
Table 7-1 Devices of I/O Base Address	47
Table 8-1 Temperature Data Format.....	55
Table 8-2 Display Registers – at SMART FAN™ I Mode	64
Table 8-3 Relative Registers – at Thermal Cruise™ Mode	65
Table 8-4 Relative Registers – at Speed Cruise™ Mode	66
Table 8-5 Relative Register-at SMART FAN™ IV Control Mode	67
Table 8-6 Relative Register-at Weight Value Control.....	72
Table 8-7 Relative Register of SMI functions	78
Table 8-8 Relative Register of OVT functions	79
Table 10-1 The Delays of the FIFO	192
Table 10-2 FDC Registers	202
Table 11-1 Register Summary for UART.....	213
Table 12-1 Pin Descriptions for SPP, EPP, and ECP Modes	225
Table 12-2 EPP Register Addresses	226
Table 12-3 Address and Bit Map for SPP and EPP Modes	226
Table 12-4 ECP Mode Description	230
Table 12-5 ECP Register Addresses.....	230
Table 12-6 Bit Map of the ECP Registers.....	230
Table 13-1 Bit Map of Status Register.....	238
Table 13-2 KBC Command Sets	239
Table 14-1 CIR Register Table	243
Table 16-1 Bit Map of Logical Device A, CR[E4h], Bits[6:5].....	260
Table 16-2 Definitions of Mouse Wake-Up Events.....	262
Table 16-3 Timing and Voltage Parameters of RSMRST#	262
Table 17-1 SERIRQ Sampling Periods	264
Table 19-1 Relative Control Registers of GPIO 44, 45, 46 and 47 that Support Wake-Up Function.....	267
Table 19-2 GPIO Group Programming Table.....	267
Table 19-3 GPIO Multi-Function Routing Table	271
Table 19-4 GPIO Register Addresses	272
Table 20-1 SB-TSI Address Encoding.....	275
Table 20-2 PCH Command Summary.....	275
Table 20-3 SMBus Master Bank 0 Registers	280
Table 21-1 Solid led configure mode	291
Table 21-2 Blink led configure mode	291
Table 21-3 Fading led configure mode.....	291

1. GENERAL DESCRIPTION

The NCT6102D / NCT6106D is a member of Nuvoton's Super I/O product line. The NCT6102D / NCT6106D monitors several critical parameters in PC hardware, including power supply voltages, fan speeds, and temperatures. In terms of temperature monitoring, the NCT6102D / NCT6106D adopts the Current Mode (dual current source) and thermistor sensor approach. The NCT6102D / NCT6106D also supports the Smart Fan control system, including "SMART FAN™ I and SMART FAN™ IV, which makes the system more stable and user-friendly.

The NCT6102D / NCT6106D supports four – 360K, 720K, 1.2M, 1.44M, or 2.88M – disk drive types and data transfer rates of 250 Kb/s, 300 Kb/s, 500 Kb/s, 1 Mb/s, and 2 Mb/s. The disk drive adapter supports the functions of floppy disk drive controller (compatible with the industry standard 82077/ 765), data separator, write pre-compensation circuit, decode logic, data rate selection, clock generator, drive interface control logic, and interrupt and DMA logic. Such a wide range of functions integrated into one NCT6102D / NCT6106D greatly reduce the number of required components to interface with floppy disk drives.

The NCT6102D supports 2 high-speed serial communication port (UART), and the NCT6106D supports 6 high-speed serial communication port (UART). Each UART includes a 128-byte send/receive FIFO, a programmable baud rate generator, complete modem-control capability, and a processor interrupt system. The UART supports legacy speeds up to 115.2K bps as well as even higher baud rates of 230K, 460K, or 921K bps to support higher speed modems.

The NCT6102D / NCT6106D supports the PC-compatible printer port (SPP), the bi-directional printer port (BPP), the enhanced parallel port (EPP) and the extended capabilities port (ECP). The NCT6102D / NCT6106D supports keyboard and mouse interface which is 8042-based keyboard controller.

The NCT6102D / NCT6106D provides flexible I/O control functions through a set of general purpose I/O (GPIO) ports. These GPIO ports may serve as simple I/O ports or may be individually configured to provide alternative functions.

The NCT6102D / NCT6106D supports the Intel® PEIC (Platform Environment Control Interface), AMD® SB-TSI interface, and Intel® Deep Sleep Well glue logic which helps customers to reduce the external circuits needed while using Deep Sleep Well function.

The NCT6102D / NCT6106D supports to decode port 80 diagnostic messages on the LPC bus. This could help on system power on debugging. It also supports two-color LED control to indicate system power states, Consumer IR function for remote control purpose, and also Advanced Power Saving function to further reduce the power consumption while the system is at S5 state.

The configuration registers inside the NCT6102D / NCT6106D support mode selection, function enable and disable, and power-down selection. Furthermore, the configurable PnP features are compatible with the plug-and-play feature in Windows, making the allocation of the system resources more efficient than ever.

2. FEATURES

General

- Meet LPC Spec. 1.1
- Support LDRQ# (LPC DMA), SERIRQ (Serialized IRQ)
- Integrated hardware monitor functions
- Support DPM (Device Power Management), ACPI (Advanced Configuration and Power Interface)
- Programmable configuration settings
- Single 24-MHz or 48-MHz clock input
- Support selective pins of 5 V tolerance

FDC

- Variable write pre-compensation with track-selection capability
- Support vertical recording format
- DMA-enable logic
- 16-byte data FIFO
- Support floppy disk drives and tape drives
- Detect all overrun and underrun conditions
- Built-in address mark detection circuit to simplify the read electronics
- FDD anti-virus functions with software write protect and FDD-write enable signal (write data signal forced to be inactive)
- Support 3.5-inch or 5.25-inch floppy disk drives
- Compatible with industry standard 82077
- 360K / 720K / 1.2M / 1.44M / 2.88M formats
- 250K, 300K, 500K, 1M, 2M bps data transfer rate
- Support 3-mode FDD and its Windows driver

UART

- NCT6102D - 2 high-speed, 16550-compatible UART with 128-byte send / receive FIFO
- NCT6106D - 6 high-speed, 16550-compatible UART with 128-byte send / receive FIFO
- Support RS485
 - Supports auto flow control
- Fully programmable serial-interface characteristics:
 - 5, 6, 7 or 8-bit characters
 - Even, odd or no parity bit generation / detection
 - 1, 1.5 or 2 stop-bit generation
- Internal diagnostic capabilities:
 - Loop-back controls for communications link fault isolation
 - Break, parity, overrun, framing error simulation
- Programmable baud rate generator allows division of clock source by any value from 1 to $(2^{16} - 1)$
- Maximum baud rate for clock source 14.769 MHz is up to 921K bps. The baud rate at 24 MHz is 1.5 M bps.



Parallel Port

- Compatible with IBM® parallel port
- Support PS/2-compatible bi-directional parallel port
- Support Enhanced Parallel Port (EPP) – Compatible with IEEE 1284 specification
- Support Extended Capabilities Port (ECP) – Compatible with IEEE 1284 specification
- Enhanced printer port back-drive current protection

Keyboard Controller

- 8042-based keyboard controller
- Asynchronous access to two data registers and one status register
- Software-compatible with 8042
- Support PS/2 mouse
- Support Port 92
- Support both interrupt and polling modes
- Fast Gate A20 and Hardware Keyboard Reset
- 12MHz operating frequency

Hardware Monitor Functions

- Smart Fan control system
- Programmable threshold temperature to speed fan fully while current temperature exceeds this threshold in the Thermal Cruise™ mode
- Support Current Mode (dual current source) temperature sensing method
- Eight voltage inputs (CPUVCORE, VIN[0..2], 3VCC, AVCC, 3VSB and VBAT)
- Three fan-speed monitoring inputs
- Three fan-speed controls
- Dual mode for fan control (PWM and DC) for SYSFANOUT, CPUFANOUT and AUXFANOUT
- Built-in case open detection circuit
- Programmable hysteresis and setting points for all monitored items
- Issue SMI#, OVT# (Over-temperature) to activate system protection
- Nuvoton Health Manager support
- Provide I²C master / slave interface to read / write registers

CIR and IR (Infrared)

- Support IrDA version 1.0 SIR protocol with maximum baud rate up to 115.2K bps
- Support SHARP ASK-IR protocol with maximum baud rate up to 57,600 bps
- Support Consumer IR, including CIRTx, CIRRx, CIRRxWB

General Purpose I/O Ports

- GPIO0 ~ GPIO7 programmable general purpose I/O ports
- Two access channels, indirect (via 2E/2F or 4E/4F) and direct (Base Address) access.

**ACPI Configuration**

- Support Glue Logic functions
- Support general purpose Watch Dog Timer functions

OnNow Functions

- Keyboard Wake-Up by programmable keys
- Mouse Wake-Up by programmable buttons
- OnNow Wake-Up from all of the ACPI sleeping states (S1-S5)

PECI Interface

- Support PECI 1.1, 2.0 and 3.0 specification
- Support 2 CPU addresses and 2 domains per CPU address

AMD SB-TSI Interface

- Support AMD[®] SB-TSI specification

SMBus Interface

- Support SMBus Slave interface to report Hardware Monitor device data
- Support SMBus Master interface to get thermal data from PCH
- Support SMBus Master interface to get thermal data from MXM module

Power Measurement

- Support Power Consumption measurement
- Fading LED driver control for power status and diagnostic indications

Advanced Power Saving

- Advanced Sleep State Control to save motherboard Stand-by power consumption

Operation voltage

- 3.3 voltage

Package

- 128-pin LQFP
- Green

3. BLOCK DIAGRAM

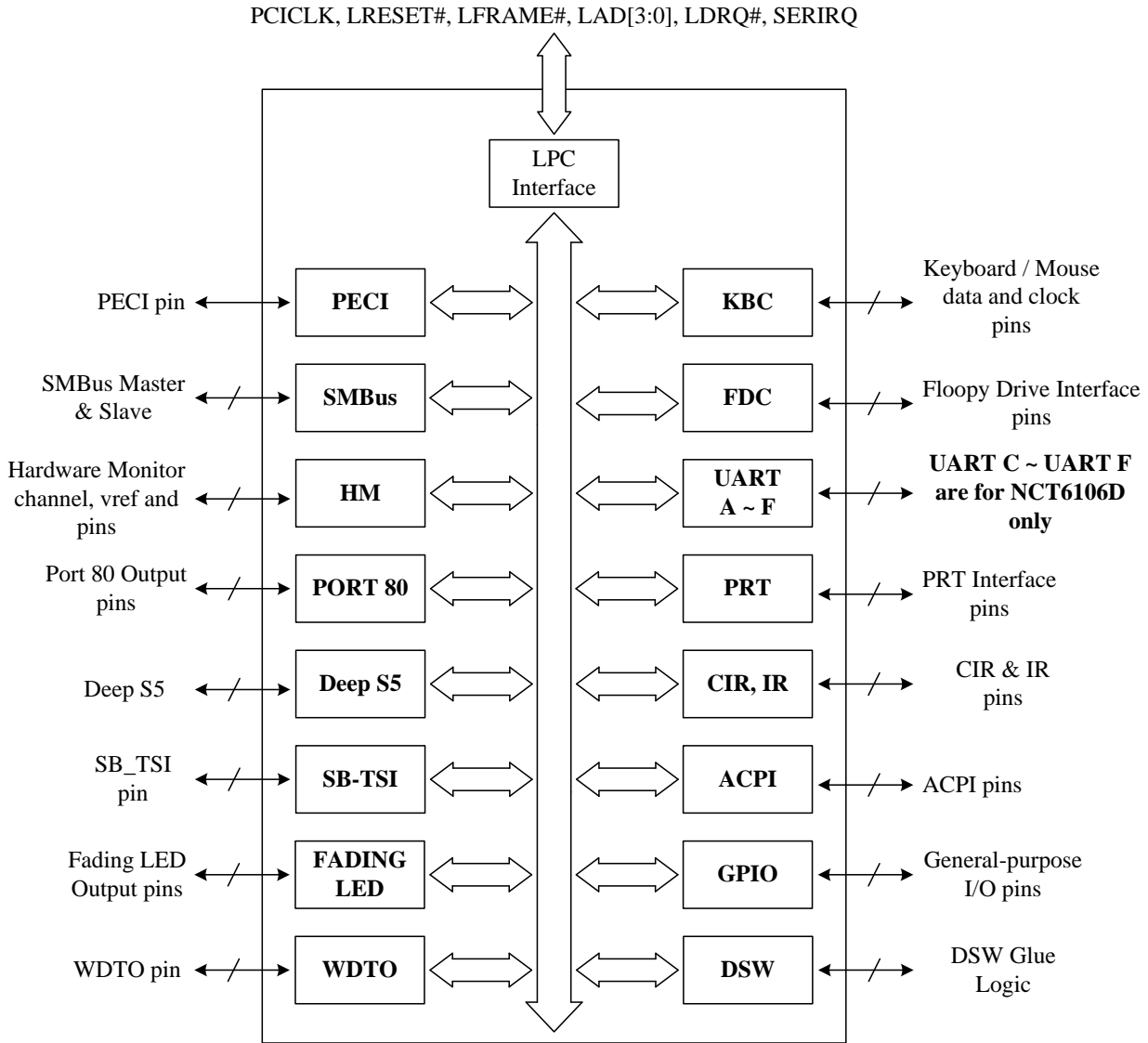

Figure 3-1 NCT6102D / NCT6106D Block Diagram

4. PIN LAYOUT

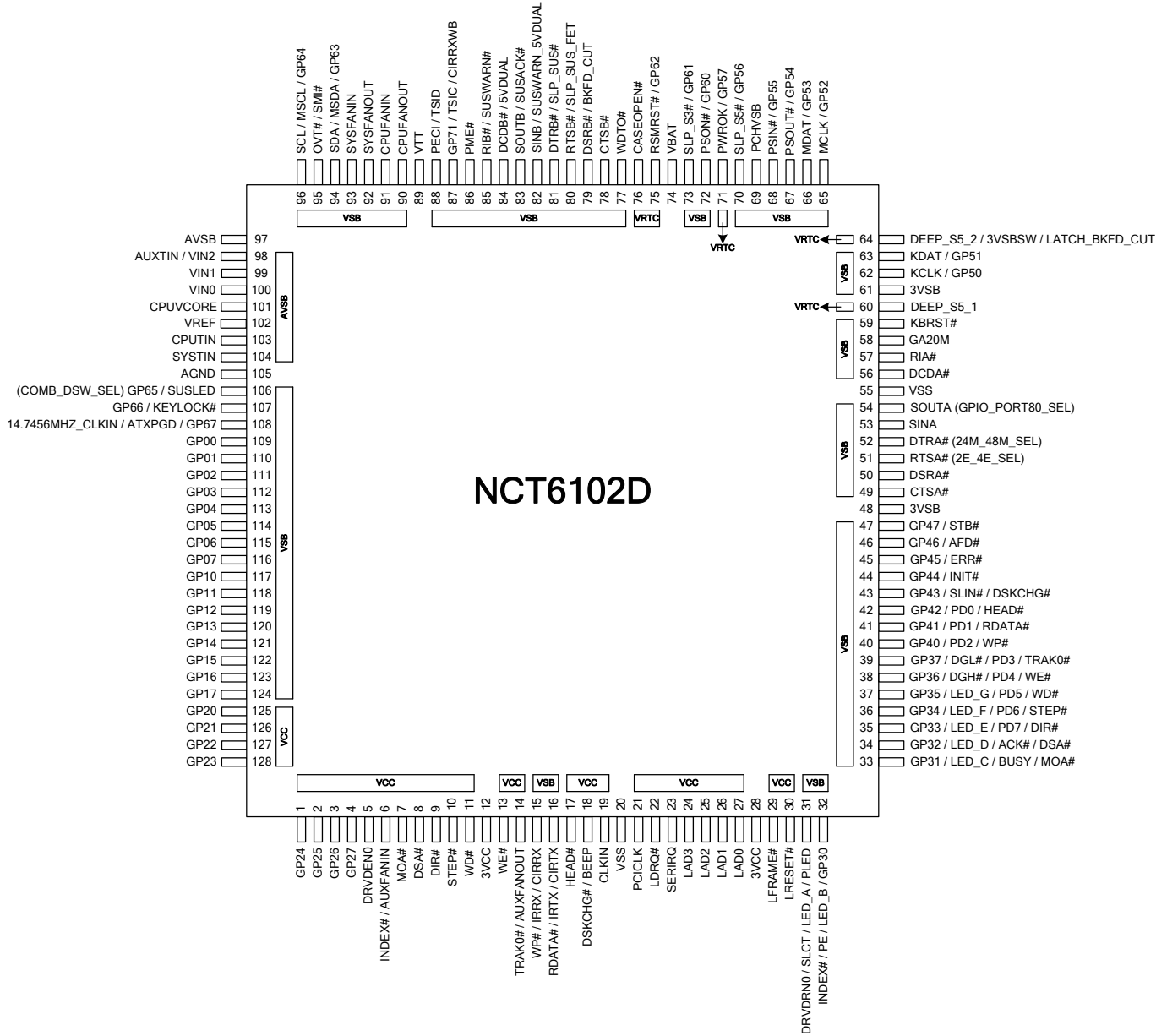

Figure 4-1 NCT6102D Pin Layout

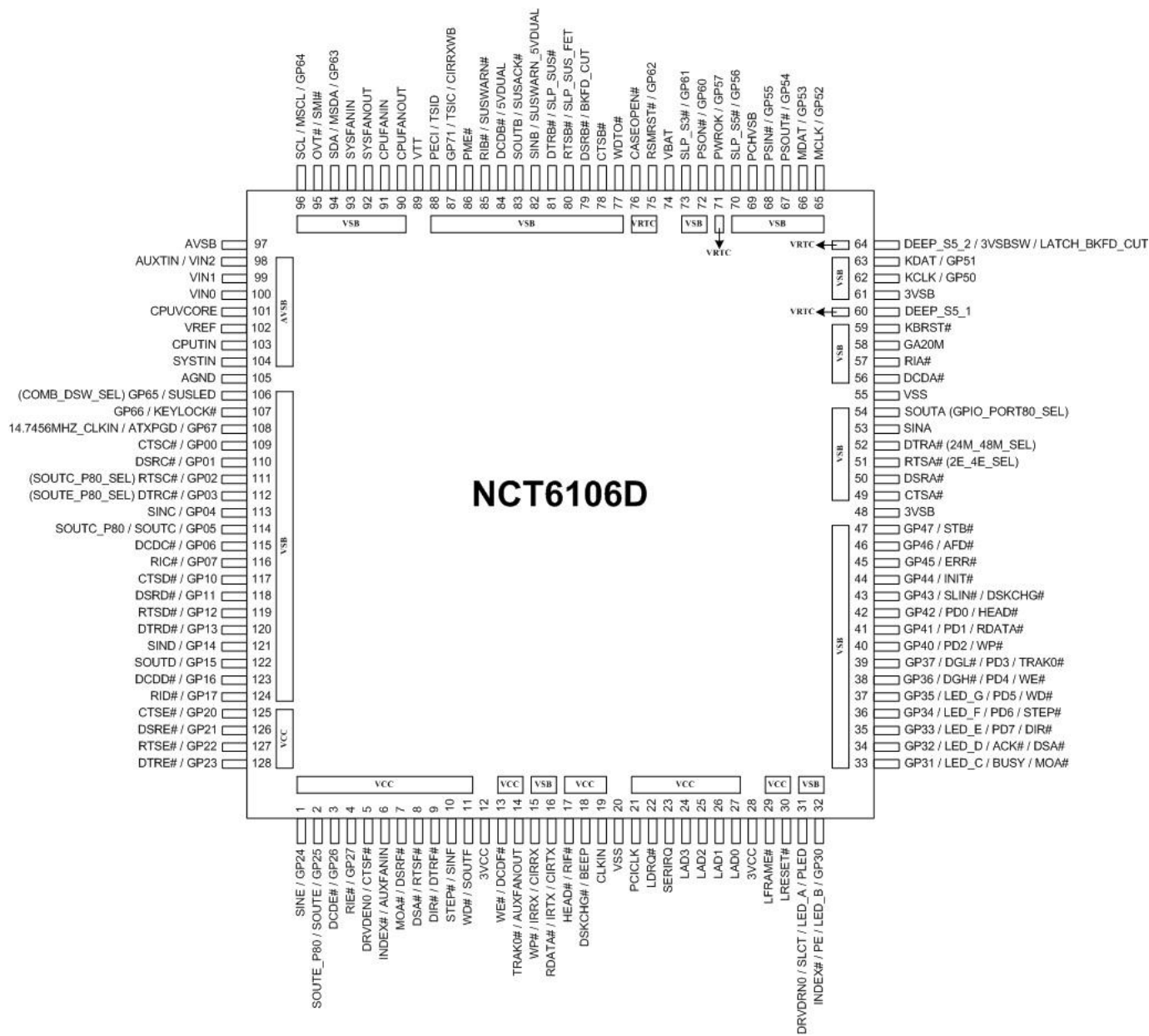

Figure 4-2 NCT6106D Pin Layout

5. PIN DESCRIPTION

Note: Please refer to 24.2 DC CHARACTERISTICS for details.

AOUT	- Analog output pin
AIN	- Analog input pin
IN _{tp3}	- 3.3V TTL-level input pin
IN _{tsp3}	- 3.3V TTL-level, Schmitt-trigger input pin
IN _{gp5}	- 5V GTL-level input pin
IN _{tp5}	- 5V TTL-level input pin
IN _{tscup5}	- 5V TTL-level, Schmitt-trigger, input buffer with controllable pull-up
IN _{tsp5}	- 5V TTL-level, Schmitt-trigger input pin
IN _{tdp5}	- 5V TTL-level input pin with internal pull-down resistor
IN _{tup5}	- 5V TTL-level input pin with internal pull-up resistor
O ₈	- output pin with 8-mA source-sink capability
OD ₈	- open-drain output pin with 8-mA sink capability
O ₁₂	- output pin with 12-mA source-sink capability
OD ₁₂	- open-drain output pin with 12-mA sink capability
O ₂₄	- output pin with 24-mA source-sink capability
OD ₂₄	- open-drain output pin with 24-mA sink capability
O ₄₈	- output pin with 48-mA source-sink capability
OD ₄₈	- open-drain output pin with 48-mA sink capability
I/O _{v3}	- Bi-direction pin with source capability of 6 mA and sink capability of 1 mA
I/O _{v4}	- Bi-direction pin with source capability of 6 mA
O _{12cu}	- output pin 12-mA source-sink capability with controllable pull-up
OD _{12cu}	- open-drain 12-mA sink capability output pin with controllable pull-up



5.1 LPC Interface

PIN	SYMBOL	I/O	BUFFER TYPE	POWER WELL	DESCRIPTION
19	CLKIN	I	IN _{tp5}	VCC	System clock input, either 24MHz or 48MHz. The actual frequency must be specified by 24M_48M_SEL strapping.
86	PME#	O	OD ₁₂	VSB	Generated PME event.
21	PCICLK	I	IN _{tp3}	VCC	PCI-clock 33-MHz input.
22	LDRQ#	O	O ₁₂	VCC	Encoded DMA Request signal.
23	SERIRQ	I/O	IN _{tp3} O ₁₂ OD ₁₂	VCC	Serialized IRQ input / output.
24-27	LAD[3:0]	I/O	IN _{tp3} OD ₁₂	VCC	These signal lines communicate address, control, and data information over the LPC bus between a host and a peripheral.
29	LFRAME#	I	IN _{tp3}	VCC	Indicates the start of a new cycle or the termination of a broken cycle.
30	LRESET#	I	IN _{tp3}	VCC	Reset signal. It can be connected to the PCIRST# signal on the host.

5.2 FDC Interface

PIN	SYMBOL	I/O	BUFFER TYPE	POWER WELL	DESCRIPTION
5	DRVDE0	O	OD ₂₄	VCC	Drive Density Select bit 0.
31	DRVDE0	O	OD ₁₂	VSB	Drive Density Select bit 0.
6	INDEX#	I	IN _{tsp5}	VCC	This Schmitt-trigger input from the disk drive is active-low when the head is positioned over the beginning of a track marked by an index hole. This input pin needs to connect a pulled-up 1-KΩ resistor to 5V for Floppy Drive compatibility.
32	INDEX#	I	IN _{tsp5}	VSB	This Schmitt-trigger input from the disk drive is active-low when the head is positioned over the beginning of a track marked by an index hole. This input pin needs to connect a pulled-up 1-KΩ resistor to 5V for Floppy Drive compatibility.
7	MOA#	O	OD ₂₄	VCC	Motor A On. When set to 0, this pin activates disk drive A. This is an open-drain output.
33	MOA#	O	OD ₁₂	VSB	Motor A On. When set to 0, this pin activates disk drive A. This is an open-drain output.
8	DSA#	O	OD ₂₄	VCC	Drive Select A. When set to 0, this pin activates disk drive A. This is an open-drain output.

PIN	SYMBOL	I/O	BUFFER TYPE	POWER WELL	DESCRIPTION
34	DSA#	O	OD ₁₂	VSB	Drive Select A. When set to 0, this pin activates disk drive A. This is an open-drain output.
9	DIR#	O	OD ₂₄	VCC	Direction of the head step motor. An open-drain output. Logic 1 = outward motion Logic 0 = inward motion
35	DIR#	O	OD ₁₂	VSB	Direction of the head step motor. An open-drain output. Logic 1 = outward motion Logic 0 = inward motion
10	STEP#	O	OD ₂₄	VCC	Step output pulses. This active-low open-drain output produces a pulse to move the head to another track.
36	STEP#	O	OD ₁₂	VSB	Step output pulses. This active-low open-drain output produces a pulse to move the head to another track.
11	WD#	O	OD ₂₄	VCC	Write data. This logic-low open-drain writes pre-compensation serial data to the selected FDD. An open-drain output.
37	WD#	O	OD ₁₂	VSB	Write data. This logic-low open-drain writes pre-compensation serial data to the selected FDD. An open-drain output.
13	WE#	O	OD ₂₄	VCC	Write enable. An open-drain output.
38	WE#	O	OD ₂₄	VSB	Write enable. An open-drain output.
14	TRAK0#	I	IN _{tsp5}	VCC	Track 0. This Schmitt-trigger input from the disk drive is active-low when the head is positioned over the outermost track. This input pin needs to connect a pulled-up 1-K Ω resistor to 5V for Floppy Drive compatibility.
39	TRAK0#	I	IN _{tsp5}	VSB	Track 0. This Schmitt-trigger input from the disk drive is active-low when the head is positioned over the outermost track. This input pin needs to connect a pulled-up 1-K Ω resistor to 5V for Floppy Drive compatibility.
15	WP#	I	IN _{tsp5}	VCC	Write protected. This active-low Schmitt input from the disk drive indicates that the diskette is write-protected. This input pin needs to connect a pulled-up 1-K Ω resistor to 5V for Floppy Drive compatibility.
40	WP#	I	IN _{tsp5}	VSB	Write protected. This active-low Schmitt input from the disk drive indicates that the diskette is write-protected. This input pin needs to connect a pulled-up 1-K Ω resistor to 5V for Floppy Drive compatibility.
16	RDATA#	I	IN _{tsp5}	VCC	The read-data input signal from the FDD. This input pin needs to connect a pulled-up 1-K Ω resistor to 5V for Floppy Drive compatibility.
41	RDATA#	I	IN _{tsp5}	VSB	The read-data input signal from the FDD. This input pin needs to connect a pulled-up 1-K Ω resistor to 5V for Floppy Drive compatibility.



PIN	SYMBOL	I/O	BUFFER TYPE	POWER WELL	DESCRIPTION
17	HEAD#	O	OD ₂₄	VCC	Head selection. This open-rain output determines which disk drive head is active. Logic 1 = side 0 Logic 0 = side 1
42	HEAD#	O	OD ₁₂	VSB	Head selection. This open-rain output determines which disk drive head is active. Logic 1 = side 0 Logic 0 = side 1
18	DSKCHG#	I	IN _{tsp5}	VCC	Diskette change. This signal is active-low at power-on and whenever the diskette is removed. This input pin needs to connect a pulled-up 1-K Ω resistor to 5V for Floppy Drive compatibility.
43	DSKCHG#	I	IN _{tsp5}	VSB	Diskette change. This signal is active-low at power-on and whenever the diskette is removed. This input pin needs to connect a pulled-up 1-K Ω resistor to 5V for Floppy Drive compatibility.

5.3 Multi-Mode Parallel Port

PIN	SYMBOL	I/O	BUFFER TYPE	POWER WELL	DESCRIPTION
31	SLCT	I	IN _{tsp5}	VSB	PRINTER MODE: An active-high input on this pin indicates that the printer is selected. See the description of the parallel port for the definition of this pin in ECP and EPP modes.
32	PE	I	IN _{tsp5}	VSB	PRINTER MODE: An active-high input on this pin indicates that the printer has detected the end of the paper. See the description of the parallel port for the definitions of this pin in ECP and EPP modes.
33	BUSY	I	IN _{tsp5}	VSB	PRINTER MODE: An active-high input indicates that the printer is not ready to receive data. See the description of the parallel port for the definitions of this pin in ECP and EPP modes.
34	ACK#	I	IN _{tsp5}	VSB	PRINTER MODE: ACK# An active-low input on this pin indicates that the printer has received data and is ready to accept more data. See the descriptions of the parallel port for the definition of this pin in ECP and EPP modes.
45	ERR#	I	IN _{tsp5}	VSB	PRINTER MODE: ERR# An active-low input on this pin indicates that the printer has encountered an error condition. See the description of the parallel port for the definitions of this pin in ECP and EPP modes.

PIN	SYMBOL	I/O	BUFFER TYPE	POWER WELL	DESCRIPTION
43	SLIN#	O	O ₁₂	VS _B	PRINTER MODE: SLIN# Output line for detection of printer selection. See the description of the parallel port for the definitions of this pin in ECP and EPP modes.
44	INIT#	O	O ₁₂	VS _B	PRINTER MODE: INIT# Output line for the printer initialization. See the description of the parallel port for the definitions of this pin in ECP and EPP modes.
46	AFD#	O	O ₁₂	VS _B	PRINTER MODE: AFD# An active-low output from this pin causes the printer to auto feed a line after a line is printed. See the description of the parallel port for the definitions of this pin in ECP and EPP modes.
47	STB#	O	O ₁₂	VS _B	PRINTER MODE: STB# An active-low output is used to latch the parallel data into the printer. See the description of the parallel port for the definitions of this pin in ECP and EPP modes.
42	PD0	I/O	IN _{tsp5} O ₁₂	VS _B	PRINTER MODE: PD0 Parallel port data bus bit 0. See the description of the parallel port for the definitions of this pin in ECP and EPP modes.
41	PD1	I/O	IN _{tsp5} O ₁₂	VS _B	PRINTER MODE: PD1 Parallel port data bus bit 1. See the description of the parallel port for the definitions of this pin in ECP and EPP modes.
40	PD2	I/O	IN _{tsp5} O ₁₂	VS _B	PRINTER MODE: PD2 Parallel port data bus bit 2. See the description of the parallel port for the definitions of this pin in ECP and EPP modes.
39	PD3	I/O	IN _{tsp5} O ₂₄	VS _B	PRINTER MODE: PD3 Parallel port data bus bit 3. See the description of the parallel port for the definitions of this pin in ECP and EPP modes.
38	PD4	I/O	IN _{tsp5} O ₂₄	VS _B	PRINTER MODE: PD4 Parallel port data bus bit 4. See the description of the parallel port for the definition of this pin in ECP and EPP modes.
37	PD5	I/O	IN _{tsp5} O ₁₂	VS _B	PRINTER MODE: PD5 Parallel port data bus bit 5. See the description of the parallel port for the definitions of this pin in ECP and EPP modes.
36	PD6	I/O	IN _{tsp5} O ₁₂	VS _B	PRINTER MODE: PD6 Parallel port data bus bit 6. See the description of the parallel port for the definitions of this pin in ECP and EPP modes.



PIN	SYMBOL	I/O	BUFFER TYPE	POWER WELL	DESCRIPTION
35	PD7	I/O	IN _{tp5} O ₂₄	VSB	PRINTER MODE: PD7 Parallel port data bus bit 7. See the description of the parallel port for the definitions of this pin in ECP and EPP modes.

5.4 Serial Port Interface (UART C ~ UART F are for NCT6106D only)

PIN	SYMBOL	I/O	BUFFER TYPE	POWER WELL	DESCRIPTION
57	RIA#	I	IN _{tp5}	VSB	Ring Indicator. An active-low signal indicates that a ring signal is being received from the modem or the data set.
56	DCDA#	I	IN _{tp5}	VSB	Data Carrier Detection. An active-low signal indicates the modem or data set has detected a data carrier.
54	SOUTA	O	O ₁₂	VSB	UART A Serial Output. This pin is used to transmit serial data out to the communication link.
53	SINA	I	IN _{tp5}	VSB	Serial Input. This pin is used to receive serial data through the communication link.
52	DTRA#	O	O ₁₂	VSB	UART A Data Terminal Ready. An active-low signal informs the modem or data set that the controller is ready to communicate.
51	RTSA#	O	O ₁₂	VSB	UART A Request To Send. An active-low signal informs the modem or data set that the controller is ready to send data.
50	DSRA#	I	IN _{tp5}	VSB	Data Set Ready. An active-low signal indicates the modem or data set is ready to establish a communication link and transfer data to the UART.
49	CTSA#	I	IN _{tp5}	VSB	Clear To Send. This is the modem-control input. The function of these pins can be tested by reading bit 4 of the handshake status register.
85	RIB#	I	IN _{tp5}	VSB	Ring Indicator. An active-low signal indicates that a ring signal is being received from the modem or the data set.
84	DCDB#	I	IN _{tp5}	VSB	Data Carrier Detection. An active-low signal indicates the modem or data set has detected a data carrier.
83	SOUTB	O	O ₁₂	VSB	UART B Serial Output. This pin is used to transmit serial data out to the communication link.
82	SINB	I	IN _{tp5}	VSB	Serial Input. This pin is used to receive serial data through the communication link.
81	DTRB#	O	O ₁₂	VSB	UART B Data Terminal Ready. An active-low signal informs the modem or data set that the controller is ready to communicate.
80	RTSB#	O	O ₁₂	VSB	UART B Request To Send. An active-low signal informs the modem or data set that the controller is ready to send data.

PIN	SYMBOL	I/O	BUFFER TYPE	POWER WELL	DESCRIPTION
79	DSRB#	I	IN _{tp5}	VSB	Data Set Ready. An active-low signal indicates the modem or data set is ready to establish a communication link and transfer data to the UART.
78	CTSB#	I	IN _{tp5}	VSB	Clear To Send. This is the modem-control input. The function of these pins can be tested by reading bit 4 of the handshake status register.
116	RIC#	I	IN _{tp5}	VSB	Ring Indicator. An active-low signal indicates that a ring signal is being received from the modem or the data set.
115	DCDC#	I	IN _{tp5}	VSB	Data Carrier Detection. An active-low signal indicates the modem or data set has detected a data carrier.
114	SOUTC	O	O ₁₂	VSB	UART C Serial Output. This pin is used to transmit serial data out to the communication link.
114	SOUTC_P80	O	O ₁₂	VSB	PORT80 to UART Serial Output. This pin is used to transmit serial data out to the communication link.
113	SINC	I	IN _{tp5}	VSB	Serial Input. This pin is used to receive serial data through the communication link.
112	DTRC#	O	O ₁₂	VSB	UART C Data Terminal Ready. An active-low signal informs the modem or data set that the controller is ready to communicate.
111	RTSC#	O	O ₁₂	VSB	UART C Request To Send. An active-low signal informs the modem or data set that the controller is ready to send data.
110	DSRC#	I	IN _{tp5}	VSB	Data Set Ready. An active-low signal indicates the modem or data set is ready to establish a communication link and transfer data to the UART.
109	CTSC#	I	IN _{tp5}	VSB	Clear To Send. This is the modem-control input. The function of these pins can be tested by reading bit 4 of the handshake status register.
124	RID#	I	IN _{tp5}	VSB	Ring Indicator. An active-low signal indicates that a ring signal is being received from the modem or the data set.
123	DCDD#	I	IN _{tp5}	VSB	Data Carrier Detection. An active-low signal indicates the modem or data set has detected a data carrier.
122	SOUTD	O	O ₁₂	VSB	UART D Serial Output. This pin is used to transmit serial data out to the communication link.
121	SIND	I	IN _{tp5}	VSB	Serial Input. This pin is used to receive serial data through the communication link.
120	DTRD#	O	O ₁₂	VSB	UART D Data Terminal Ready. An active-low signal informs the modem or data set that the controller is ready to communicate.
119	RTSD#	O	O ₁₂	VSB	UART D Request To Send. An active-low signal informs the modem or data set that the controller is ready to send data.

PIN	SYMBOL	I/O	BUFFER TYPE	POWER WELL	DESCRIPTION
118	DSRD#	I	IN _{tp5}	VSB	Data Set Ready. An active-low signal indicates the modem or data set is ready to establish a communication link and transfer data to the UART.
117	CTSD#	I	IN _{tp5}	VSB	Clear To Send. This is the modem-control input. The function of these pins can be tested by reading bit 4 of the handshake status register.
4	RIE#	I	IN _{tp5}	VCC	Ring Indicator. An active-low signal indicates that a ring signal is being received from the modem or the data set.
3	DCDE#	I	IN _{tp5}	VCC	Data Carrier Detection. An active-low signal indicates the modem or data set has detected a data carrier.
2	SOUTE	O	O ₁₂	VCC	UART E Serial Output. This pin is used to transmit serial data out to the communication link.
2	SOUTE_P80	O	O ₁₂	VCC	PORT80 to UART Serial Output. This pin is used to transmit serial data out to the communication link.
1	SINE	I	IN _{tp5}	VCC	Serial Input. This pin is used to receive serial data through the communication link.
128	DTRE#	O	O ₁₂	VCC	UART E Data Terminal Ready. An active-low signal informs the modem or data set that the controller is ready to communicate.
127	RTSE#	O	O ₁₂	VCC	UART E Request To Send. An active-low signal informs the modem or data set that the controller is ready to send data.
126	DSRE#	I	IN _{tp5}	VCC	Data Set Ready. An active-low signal indicates the modem or data set is ready to establish a communication link and transfer data to the UART.
125	CTSE#	I	IN _{tp5}	VCC	Clear To Send. This is the modem-control input. The function of these pins can be tested by reading bit 4 of the handshake status register.
17	RIF#	I	IN _{tp5}	VCC	Ring Indicator. An active-low signal indicates that a ring signal is being received from the modem or the data set.
13	DCDF#	I	IN _{tp5}	VCC	Data Carrier Detection. An active-low signal indicates the modem or data set has detected a data carrier.
11	SOUTF	O	O ₂₄	VCC	UART F Serial Output. This pin is used to transmit serial data out to the communication link.
10	SINF	I	IN _{tp5}	VCC	Serial Input. This pin is used to receive serial data through the communication link.
9	DTRF#	O	O ₂₄	VCC	UART F Data Terminal Ready. An active-low signal informs the modem or data set that the controller is ready to communicate.
8	RTSF#	O	O ₂₄	VCC	UART F Request To Send. An active-low signal informs the modem or data set that the controller is ready to send data.



PIN	SYMBOL	I/O	BUFFER TYPE	POWER WELL	DESCRIPTION
7	DSRF#	I	IN _{tp5}	VCC	Data Set Ready. An active-low signal indicates the modem or data set is ready to establish a communication link and transfer data to the UART.
5	CTSF#	I	IN _{tp5}	VCC	Clear To Send. This is the modem-control input. The function of these pins can be tested by reading bit 4 of the handshake status register.
108	14.7456MHZ_CLKIN	I	IN _{tp5}	VSB	UART-clock 14.7456-MHz input

5.5 KBC Interface

PIN	SYMBOL	I/O	BUFFER TYPE	POWER WELL	DESCRIPTION
58	GA20M	O	O ₁₂	VSB	Gate A20 output. This pin is high after system reset. (KBC P21)
59	KBRST#	O	O ₁₂	VSB	Keyboard reset. This pin is high after system reset. (KBC P20)
62	KCLK	I/O	IN _{tsp5} OD ₁₂	VSB	Keyboard Clock.
63	KDAT	I/O	IN _{tsp5} OD ₁₂	VSB	Keyboard Data.
65	MCLK	I/O	IN _{tsp5} OD ₁₂	VSB	PS2 Mouse Clock.
66	MDAT	I/O	IN _{tsp5} OD ₁₂	VSB	PS2 Mouse Data.
107	KEYLOCK#	I	IN _{tup5}	VSB	Keyboard inhibits control bits. This pin is after system reset. Internal pull high. (KBC P17)

5.6 CIR Interface

PIN	SYMBOL	I/O	BUFFER TYPE	POWER WELL	DESCRIPTION
15	CIRRX	I	IN _{tsp5}	VSB	CIR input for long length
16	CIRTX	O	O ₁₂	VSB	CIR transmission output
87	CIRRXWB	I	IN _{tp5}	VSB	CIR input for wide band

5.7 Hardware Monitor Interface

PIN	SYMBOL	I/O	BUFFER TYPE	POWER WELL	DESCRIPTION
-----	--------	-----	-------------	------------	-------------

PIN	SYMBOL	I/O	BUFFER TYPE	POWER WELL	DESCRIPTION
76	CASEOPEN#	I	IN _{tp5}	VRTC	CASE OPEN detection. An active-low input from an external device when the case is open. This signal can be latched if pin VBAT is connected to the battery, even if the system is in G3 state. Pulling up a 2-MΩ resistor to VBAT is recommended if not in use.
98	VIN2 / AUX TIN	I	AIN	AVSB	Analog input for voltage measurement (Range: 0 to 2.048 V)
99	VIN1	I	AIN	AVSB	Analog input for voltage measurement (Range: 0 to 2.048 V)
100	VIN0	I	AIN	AVSB	Analog input for voltage measurement (Range: 0 to 2.048 V)
101	CPUV CORE	I	AIN	AVSB	Analog input for voltage measurement (Range: 0 to 2.048 V)
102	VREF	O	AOUT	AVSB	Reference Voltage (around 2.048 V).
103	CPUTIN	I	AIN	AVSB	The input of temperature sensor 2. It is used for CPU temperature sensing.
104	SYSTIN	I	AIN	AVSB	The input of temperature sensor 1. It is used for system temperature sensing.
95	OVT#	O	OD ₁₂	VSB	The output of over temperature Shutdown. This pin indicates the temperature is over the temperature limit. (Default after LRESET#)
95	SMI#	O	OD ₁₂	VSB	System Management Interrupt channel output.
6	AUXFANIN	I	IN _{tsp5}	VCC	0 to +5 V amplitude fan tachometer input.
14	AUXFANOUT	O	AOUT O ₁₂ OD ₁₂	VCC	PWM duty-cycle signal for fan speed control.
91	CPUFANIN	I	IN _{tsp5}	VSB	0 to +5 V amplitude fan tachometer input.
90	CPUFANOUT	O	AOUT O ₁₂ OD ₁₂	VSB	PWM duty-cycle signal for fan speed control.
93	SYSFANIN	I	IN _{tsp5}	VSB	0 to +5 V amplitude fan tachometer input.
92	SYSFANOUT	O	AOUT O ₁₂ OD ₁₂	VSB	PWM duty-cycle signal for fan speed control. DC voltage output for fan speed control.
18	BEEP	O	OD ₁₂	VCC	Beep function for hardware monitor.

5.8 Intel® PECCI Interface



PIN	SYMBOL	I/O	BUFFER TYPE	POWER WELL	DESCRIPTION
88	PECI	I/O	I/O _{V3}	Vtt	INTEL® CPU PECI interface. Connect to CPU.
89	VTT	I	Power	Vtt	INTEL® CPU Vtt Power.

5.9 Advanced Configuration & Power Interface

PIN	SYMBOL	I/O	BUFFER TYPE	POWER WELL	DESCRIPTION
68	PSIN#	I	IN _{tp5}	VSB	Panel Switch Input. This pin is active-low with an internal pulled-up resistor.
67	PSOUT#	O	OD ₁₂	VSB	Panel Switch Output. This signal is used to wake-up the system from S3/S5 state.
75	RSMRST#	O	OD ₁₂	VRTC	Resume reset signal output.
73	SLP_S3#	I	IN _{tp5}	VSB	SLP_S3# input.
70	SLP_S5#	I	IN _{tp5}	VSB	SLP_S5# input.
108	ATXPGD	I	IN _{tp5}	VSB	ATX power good signal.
72	PSON#	O	OD ₁₂	VSB	Power supply on-off output.
71	PWROK	O	O ₁₂ OD ₁₂	VRTC	3VCC PWROK signal.
64	3VSBSW#	O	OD ₂₄	VRTC	Switch 3VSB power to memory when in S3 state.

5.10 Advanced Sleep State Control Control

PIN	SYMBOL	I/O	BUFFER TYPE	POWER WELL	DESCRIPTION
60	DEEP_S5_1	O	OD ₂₄	VSB	This pin is to control system power for entering "more power saving mode".
64	DEEP_S5_2	O	OD ₂₄	VSB	This pin is to control system power for entering "more power saving mode".

5.11 Port 80 Message Display

PIN	SYMBOL	I/O	BUFFER TYPE	POWER WELL	DESCRIPTION
38	DGH#	O	O ₂₄	VSB	Common cathode output of high nibble display on decoded Port 0x80h message. Switching frequency is about 4 KHz.
39	DGL#	O	O ₂₄	VSB	Common cathode output of low nibble display on decoded Port 0x80h message. Switching frequency is about 4 KHz.
31	LED_A	O	O ₁₂	VSB	Anode outputs for 7-Segment LED.



PIN	SYMBOL	I/O	BUFFER TYPE	POWER WELL	DESCRIPTION
32	LED_B	O	O ₁₂	VSB	Anode outputs for 7-Segment LED.
33	LED_C	O	O ₁₂	VSB	Anode outputs for 7-Segment LED.
34	LED_D	O	O ₁₂	VSB	Anode outputs for 7-Segment LED.
35	LED_E	O	O ₁₂	VSB	Anode outputs for 7-Segment LED.
36	LED_F	O	O ₁₂	VSB	Anode outputs for 7-Segment LED.
37	LED_G	O	O ₁₂	VSB	Anode outputs for 7-Segment LED.

5.12 SMBus Interface

PIN	SYMBOL	I/O	BUFFER TYPE	POWER WELL	DESCRIPTION
96	SCL	I/O	IN _{tsp5} OD ₁₂	VSB	SMBus slave clock.
94	SDA	I/O	IN _{tsp5} OD ₁₂	VSB	SMBus slave bi-directional Data.
96	MSCL	I/O	IN _{tsp5} OD ₁₂	VSB	SMBus master clock.
94	MSDA	I/O	IN _{tsp5} OD ₁₂	VSB	SMBus master bi-directional Data.

5.13 Power Pins

PIN	SYMBOL	I/O	BUFFER TYPE	POWER WELL	DESCRIPTION
48, 61	3VSB	I		3VSB	+3.3 V stand-by power supply for the digital circuits.
74	VBAT	I		VBAT	+3 V on-board battery for the digital circuits.
12, 28	3VCC	I		3VCC	+3.3 V power supply for driving 3 V on host interface.
97	AVSB	I		AVSB	Analog +3.3 V power input. Internally supply power to all analog circuits.
105	CPUD- / AGND	I		CPUD- / AGND	Analog ground. The ground reference for all analog input. Internally connected to all analog circuits. This pin should be connected to ground.
20, 55	VSS	I		VSS	Ground.
89	VTT	I		VTT	INTEL® CPU Vtt power.

5.14 AMD SB-TSI Interface

PIN	SYMBOL	I/O	BUFFER TYPE	POWER WELL	DESCRIPTION
-----	--------	-----	-------------	------------	-------------



PIN	SYMBOL	I/O	BUFFER TYPE	POWER WELL	DESCRIPTION
87	TSIC	O	OD ₁₂	VCC	AMD SB-TSI clock output.
88	TSID	I/O	IN _{tsp3} OD ₁₂	VCC	AMD SB-TSI data input / output.

5.15 Dual Voltage Control

PIN	SYMBOL	I/O	BUFFER TYPE	POWER WELL	DESCRIPTION
79	BKFD_CUT	O	OD ₁₂	VSB	Power distribution control (When switching between main and standby regulators) for system transition into and out of the S3 sleep state.
64	LATCH_BK FD_CUT	O	O ₂₄	VRTC	Power distribution control (When switching between main and standby regulators) for system transition into and out of the S5 sleep state.

5.16 DSW

PIN	SYMBOL	I/O	BUFFER TYPE	POWER WELL	DESCRIPTION
81	SLP_SUS#	I	IN _{tp5}	VSB	This pin connects to SLP_SUS# in CPT PCH
82	SUSWARN _5VDUAL	O	OD ₁₂	VSB	This pin links to external 5VDUAL control circuits
83	SUSACK#	O	OD ₁₂	VSB	This pin connects to SUSACK# in CPT PCH
84	5VDUAL	I	AIN	VSB	Analog input to monitor 5VDUAL voltage
85	SUSWARN #	I	IN _{tp5}	VSB	This pin connects to SUSWARN# in CPT PCH
80	SLP_SUS_ FET	O	OD ₁₂	VSB	This pin connects to VSB power switch
69	PCHVSB	I	AIN	VSB	PCHVSB function

5.17 WatchDog

PIN	SYMBOL	I/O	BUFFER TYPE	POWER WELL	DESCRIPTION
77	WDTO#	O		VSB	Watchdog Timer output signal.

5.18 IR

PIN	SYMBOL	I/O	BUFFER TYPE	POWER WELL	DESCRIPTION
15	IRRX	I	IN _{tsp5}	VSB	IR Receiver input.
16	IRTX	O	O ₁₂	VSB	IR Transmitter output.



5.19 SUSPEND LED

PIN	SYMBOL	I/O	BUFFER TYPE	POWER WELL	DESCRIPTION
106	SUSLED	O	O ₁₂	VSB	Suspend Led signal. This pin can be reflects sleep s5 state through fading led register setting.

5.20 General Purpose I/O Port

5.20.1 GPIO-0 Interface

PIN	SYMBOL	I/O	BUFFER TYPE	POWER WELL	DESCRIPTION
109	GP00	I/O	IN _{tp5} O ₁₂ OD ₁₂	VSB	General-purpose I/O port 0 bit 0.
110	GP01	I/O	IN _{tp5} O ₁₂ OD ₁₂	VSB	General-purpose I/O port 0 bit 1.
111	GP02	I/O	IN _{tp5} O ₁₂ OD ₁₂	VSB	General-purpose I/O port 0 bit 2.
112	GP03	I/O	IN _{tp5} O ₁₂ OD ₁₂	VSB	General-purpose I/O port 0 bit 3.
113	GP04	I/O	IN _{tp5} O ₁₂ OD ₁₂	VSB	General-purpose I/O port 0 bit 4.
114	GP05	I/O	IN _{tp5} O ₁₂ OD ₁₂	VSB	General-purpose I/O port 0 bit 5.
115	GP06	I/O	IN _{tp5} O ₁₂ OD ₁₂	VSB	General-purpose I/O port 0 bit 6.
116	GP07	I/O	IN _{tp5} O ₁₂ OD ₁₂	VSB	General-purpose I/O port 0 bit 7.

5.20.2 GPIO-1 Interface

PIN	SYMBOL	I/O	BUFFER TYPE	POWER WELL	DESCRIPTION
-----	--------	-----	-------------	------------	-------------

PIN	SYMBOL	I/O	BUFFER TYPE	POWER WELL	DESCRIPTION
117	GP10	I/O	IN _{tp5} O ₁₂ OD ₁₂	VSB	General-purpose I/O port 1 bit 0.
118	GP11	I/O	IN _{tp5} O ₁₂ OD ₁₂	VSB	General-purpose I/O port 1 bit 1.
119	GP12	I/O	IN _{tp5} O ₁₂ OD ₁₂	VSB	General-purpose I/O port 1 bit 2.
120	GP13	I/O	IN _{tp5} O ₁₂ OD ₁₂	VSB	General-purpose I/O port 1 bit 3.
121	GP14	I/O	IN _{tp5} O ₁₂ OD ₁₂	VSB	General-purpose I/O port 1 bit 4.
122	GP15	I/O	IN _{tp5} O ₁₂ OD ₁₂	VSB	General-purpose I/O port 1 bit 5.
123	GP16	I/O	IN _{tp5} O ₁₂ OD ₁₂	VSB	General-purpose I/O port 1 bit 6.
124	GP17	I/O	IN _{tp5} O ₁₂ OD ₁₂	VSB	General-purpose I/O port 1 bit 7.

5.20.3 GPIO-2 Interface

PIN	SYMBOL	I/O	BUFFER TYPE	POWER WELL	DESCRIPTION
125	GP20	I/O	IN _{tp5} O ₁₂ OD ₁₂	VCC	General-purpose I/O port 2 bit 0.
126	GP21	I/O	IN _{tp5} O ₁₂ OD ₁₂	VCC	General-purpose I/O port 2 bit 1.

PIN	SYMBOL	I/O	BUFFER TYPE	POWER WELL	DESCRIPTION
127	GP22	I/O	IN _{tp5} O ₁₂ OD ₁₂	VCC	General-purpose I/O port 2 bit 2.
128	GP23	I/O	IN _{tp5} O ₁₂ OD ₁₂	VCC	General-purpose I/O port 2 bit 3.
1	GP24	I/O	IN _{tp5} O ₁₂ OD ₁₂	VCC	General-purpose I/O port 2 bit 4.
2	GP25	I/O	IN _{tp5} O ₁₂ OD ₁₂	VCC	General-purpose I/O port 2 bit 5.
3	GP26	I/O	IN _{tp5} O ₁₂ OD ₁₂	VCC	General-purpose I/O port 2 bit 7.
4	GP27	I/O	IN _{tp5} O ₁₂ OD ₁₂	VCC	General-purpose I/O port 2 bit 7.

5.20.4 GPIO-3 Interface

PIN	SYMBOL	I/O	BUFFER TYPE	POWER WELL	DESCRIPTION
32	GP30	I/O	IN _{tsp5} O ₁₂ OD ₁₂	VSB	General-purpose I/O port 3 bit 0.
33	GP31	I/O	IN _{tsp5} O ₁₂ OD ₁₂	VSB	General-purpose I/O port 3 bit 1.
34	GP32	I/O	IN _{tsp5} O ₁₂ OD ₁₂	VSB	General-purpose I/O port 3 bit 2.
35	GP33	I/O	IN _{tsp5} O ₁₂ OD ₁₂	VSB	General-purpose I/O port 3 bit 3.



PIN	SYMBOL	I/O	BUFFER TYPE	POWER WELL	DESCRIPTION
36	GP34	I/O	IN _{tsp5} O ₁₂ OD ₁₂	VSB	General-purpose I/O port 3 bit 4.
37	GP35	I/O	IN _{tsp5} O ₁₂ OD ₁₂	VSB	General-purpose I/O port 3 bit 5.
38	GP36	I/O	IN _{tsp5} O ₂₄ OD ₂₄	VSB	General-purpose I/O port 3 bit 6.
39	GP37	I/O	IN _{tsp5} O ₂₄ OD ₂₄	VSB	General-purpose I/O port 3 bit 7.

5.20.5 GPIO-4 Interface

PIN	SYMBOL	I/O	BUFFER TYPE	POWER WELL	DESCRIPTION
40	GP40	I/O	IN _{tsp5} O ₁₂ OD ₁₂	VSB	General-purpose I/O port 4 bit 0.
41	GP41	I/O	IN _{tsp5} O ₁₂ OD ₁₂	VSB	General-purpose I/O port 4 bit 1.
42	GP42	I/O	IN _{tsp5} O ₁₂ OD ₁₂	VSB	General-purpose I/O port 4 bit 2.
43	GP43	I/O	IN _{tsp5} O ₁₂ OD ₁₂	VSB	General-purpose I/O port 4 bit 3.
44	GP44	I/O	IN _{tsp5} O ₁₂ OD ₁₂	VSB	General-purpose I/O port 4 bit 4.
45	GP45	I/O	IN _{tsp5} O ₁₂ OD ₁₂	VSB	General-purpose I/O port 4 bit 5.



PIN	SYMBOL	I/O	BUFFER TYPE	POWER WELL	DESCRIPTION
46	GP46	I/O	IN _{tsp5} O ₁₂ OD ₁₂	VSB	General-purpose I/O port 4 bit 6.
47	GP47	I/O	IN _{tsp5} O ₁₂ OD ₁₂	VSB	General-purpose I/O port 4 bit 7.

5.20.6 GPIO-5 Interface

PIN	SYMBOL	I/O	BUFFER TYPE	POWER WELL	DESCRIPTION
62	GP50	I/O	IN _{tsp5} O ₁₂ OD ₁₂	VSB	General-purpose I/O port 5 bit 0.
63	GP51	I/O	IN _{tsp5} O ₁₂ OD ₁₂	VSB	General-purpose I/O port 5 bit 1.
65	GP52	I/O	IN _{tsp5} O ₁₂ OD ₁₂	VSB	General-purpose I/O port 5 bit 2.
66	GP53	I/O	IN _{tsp5} O ₁₂ OD ₁₂	VSB	General-purpose I/O port 5 bit 3.
67	GP54	I/O	IN _{tp5} O ₁₂ OD ₁₂	VSB	General-purpose I/O port 5 bit 4.
68	GP55	I/O	IN _{tp5} O ₈ OD ₈	VSB	General-purpose I/O port 5 bit 5.
70	GP56	I/O	IN _{tp5} O ₁₂ OD ₁₂	VSB	General-purpose I/O port 5 bit 6.
71	GP57	I/O	IN _{tp5} O ₁₂ OD ₁₂	VSB	General-purpose I/O port 5 bit 7.

5.20.7 GPIO-6 Interface



PIN	SYMBOL	I/O	BUFFER TYPE	POWER WELL	DESCRIPTION
72	GP60	I/O	IN _{tp5} O ₁₂ OD ₁₂	VSB	General-purpose I/O port 6 bit 0.
73	GP61	I/O	IN _{tp5} O ₁₂ OD ₁₂	VSB	General-purpose I/O port 6 bit 1.
75	GP62	I/O	IN _{tp5} O ₁₂ OD ₁₂	VSB	General-purpose I/O port 6 bit 2.
94	GP63	I/O	IN _{tsp5} O ₁₂ OD ₁₂	VSB	General-purpose I/O port 6 bit 3.
96	GP64	I/O	IN _{tsp5} O ₁₂ OD ₁₂	VSB	General-purpose I/O port 6 bit 4.
106	GP65	I/O	IN _{tp5} O ₁₂ OD ₁₂	VSB	General-purpose I/O port 6 bit 5.
107	GP66	I/O	IN _{tp5} O ₁₂ OD ₁₂	VSB	General-purpose I/O port 6 bit 6.
108	GP67	I/O	IN _{tp5} O ₁₂ OD ₁₂	VSB	General-purpose I/O port 6 bit 7.

5.20.8 GPIO-7 Interface

PIN	SYMBOL	I/O	BUFFER TYPE	POWER WELL	DESCRIPTION
87	GP71	I/O	IN _{tp5} O ₁₂ OD ₁₂	VSB	General-purpose I/O port 7 bit 1.

5.21 Strapping Pins

PIN	SYMBOL	I/O	BUFFER TYPE	POWER WELL	DESCRIPTION
-----	--------	-----	-------------	------------	-------------



PIN	SYMBOL	I/O	BUFFER TYPE	POWER WELL	DESCRIPTION
51	2E_4E_SEL	I	IN _{tdp5}	VSB	SIO I/O address selection. (Strapped by LRESET#) Strapped to high: SIO I/O address is 4Eh/4Fh. Strapped to low: SIO I/O address is 2Eh/2Fh.
52	24M_48M_SEL	I	IN _{tdp5}	VSB	Input clock rate selection (Strapped by VCC [internal Power OK signal without any delay]) Strapped to high: The clock input on pin 19 is 48MHz. Strapped to low: The clock input on pin 19 is 24MHz.
54	GPIO_PORT_80_SEL	I	IN _{tdp5}	VSB	Function selection. (Strapped by VCC [internal Power OK signal without any delay]) See configuration register.
106	COMB_DSW_SEL	I	IN _{tdp5}	VSB	Pin78-85 function selection. (Strapped by VSB power [internal RSMRST# signal]) Strapped to high: DSW Strapped to low: UART
111	SOUTC_P80_SEL	I	IN _{tdp5}	VSB	Pin114 function selection. (Strapped by VCC [internal Power OK signal without any delay]) See configuration register.
112	SOUTE_P80_SEL	I	IN _{tdp5}	VSB	Pin2 function selection. (Strapped by VCC [internal Power OK signal without any delay]) See configuration register.

Note . All Strapping results can be programming by LPC Interface. There are three conditions below:

- 1) VSB Strapping result can be programming by LPC, and reset by RSMRST#.
- 2) VCC Strapping result can be programming by LPC, and reset by PWROK.
- 3) LRESET# Strapping (2E_4E_SEL) can be programming by LPC, and reset by LRESET#.

5.22 Internal pull-up, pull-down pins

Signal	Pin(s)	Power well	Type	Resistor	Note
Strapping Pins					
2E_4E_SEL	51	VSB	Pull-down	47.4K	1

Signal	Pin(s)	Power well	Type	Resistor	Note
24M_48M_SEL	52	VSB	Pull-down	47.4K	1
GPIO_PORT80_SEL	54	VSB	Pull-down	47.4K	1
COMB_DSW_SEL	106	VSB	Pull-down	47.4K	2
SOUTC_P80_SEL	111	VSB	Pull-down	47.4K	1
SOUTE_P80_SEL	112	VSB	Pull-down	47.4K	1
Advanced Configuration & Power Interface					
PSIN#	68	VSB	Pull-up	47.03K	
KEYLOCK#	107	VSB	Pull-up	47.03K	

Note1. Active only during VCC Power-up reset

Note2. Active only during VSB Power-up reset

6. GLUE LOGIC

6.1 ACPI Glue Logic

Table 6-1 Pin Description

SYMBOL	PIN	DESCRIPTION
SLP_S5#	70	SLP_S5# input.
PWROK	71	This pin generates the PWROK signals while 3VCC is present.
RSMRST#	75	The RSMRST# signal is a reset output and is used as the VSB power on reset signal for the South Bridge. When the NCT6102D / NCT6106D detects the 3VSB voltage rises to "V1", it then starts a delay – "t1" before the rising edge of RSMRST# asserting. If the 3VSB voltage falls below "V2", the RSMRST# de-asserts immediately.

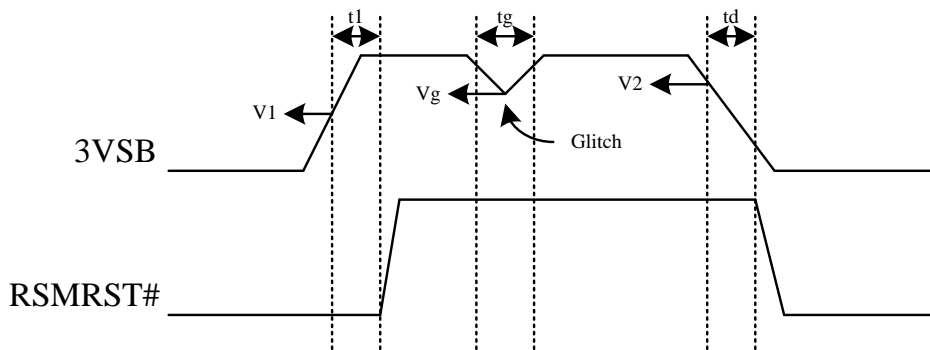

Figure 6-1 RSMRST#

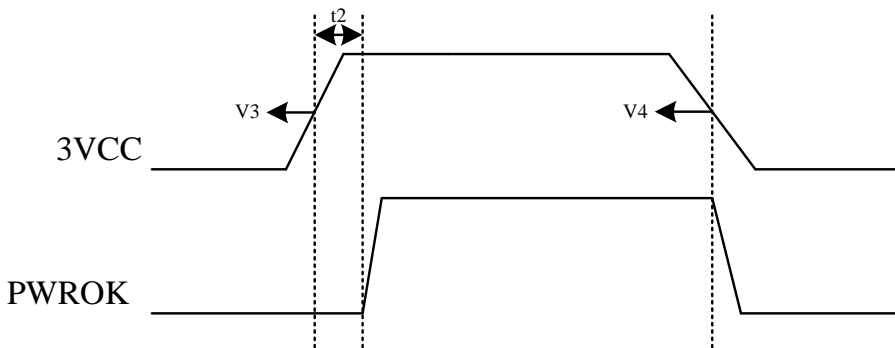

Figure 6-2 PWROK

TIMING	PARAMETER	MIN	MAX	UNIT
t1	Valid 3VSB to RSMRST# inactive	200	300	mS
tg	3VSB Glitch allowance		1	uS
td	Falling 3VSB supply Delay		1	uS
t2	Valid 3VCC to PWROK active	300	500	mS

DC	PARAMETER	MIN	MAX	UNIT
V1	3VSB Valid Voltage	-	3.033	Volt
V2	3VSB Ineffective Voltage	2.882	-	Volt
V3	3VCC Valid Voltage	-	2.83	Volt
V4	3VCC Ineffective Voltage	2.68	-	Volt
Vg	3VSB drops by Power noise	2	-	Volt

Note : 1. The values above are the worst-case results of R&D simulation.

6.2 BKFD_CUT & LATCH_BKFD_CUT

NCT6102D / NCT6106D supports BKFD_CUT & LATCH_BKFD_CUT functions, please refer the timing diagram below.

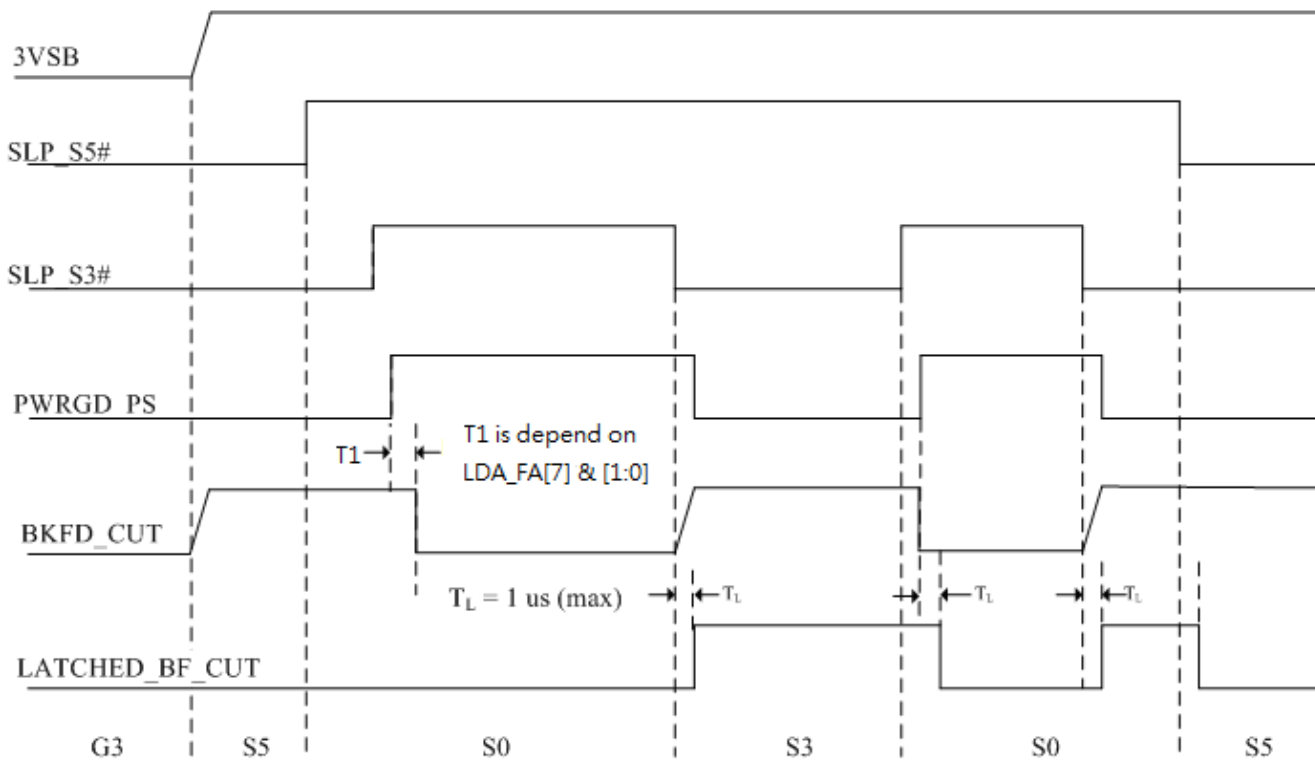

Figure 6-3 BKFD_CUT and LATCH_BKFD_CUT

BKFD_CUT (Backfeed_Cut) – When high, switches dual rails to standby power.

LATCH_BKFD_CUT (Latched_Backfeed_Cut) – When high, switches dual rails to standby power.

6.3 3VSBSW#

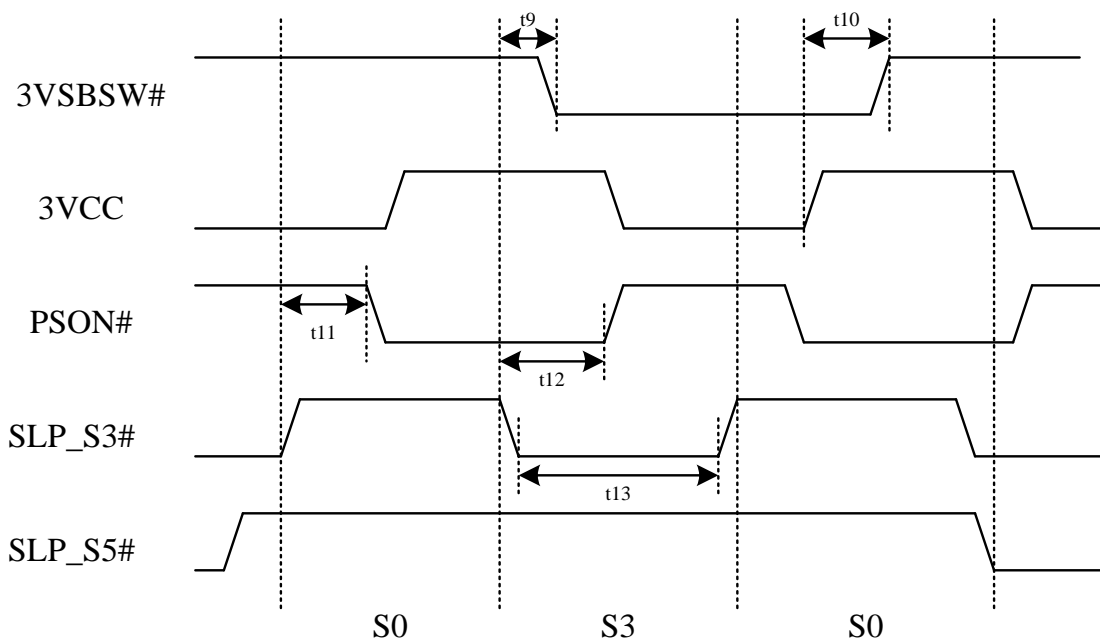

Figure 6-4 3VSBSW#

TIMING	PARAMETER	MIN	MAX	UNIT
t3	SLP_S3# active to 3VSBSW# active	0	30	mS
t4	3VCC active to 3VSBSW# inactive	90	142	mS
t5	SLP_S3# inactive to PSON# active	0	80	nS
t6	SLP_S3# active to PSON# inactive	15	45	mS
t7	SLP_S3# minimal Low Time	40	-	mS

6.4 PSIN# Block Diagram

The PSIN# function controls the main power on/off. The main power is turned on when PSIN# is low. Please refer to the figure below.

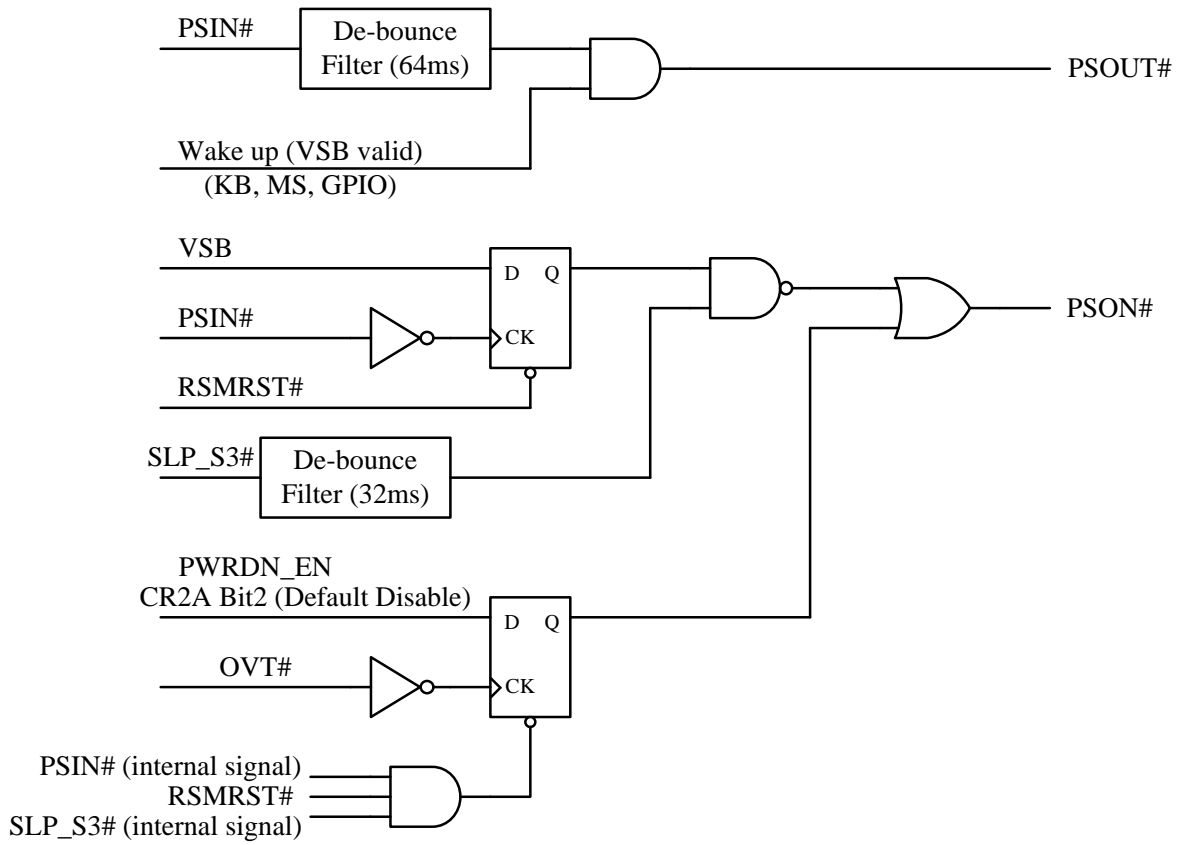

Figure 6-5 PSIN#

6.5 PWROK

PWROK Signal indicates the main power (VCC Power) is valid. Besides, valid PWROK signal also requires the following conditions, as shown in the figure below.

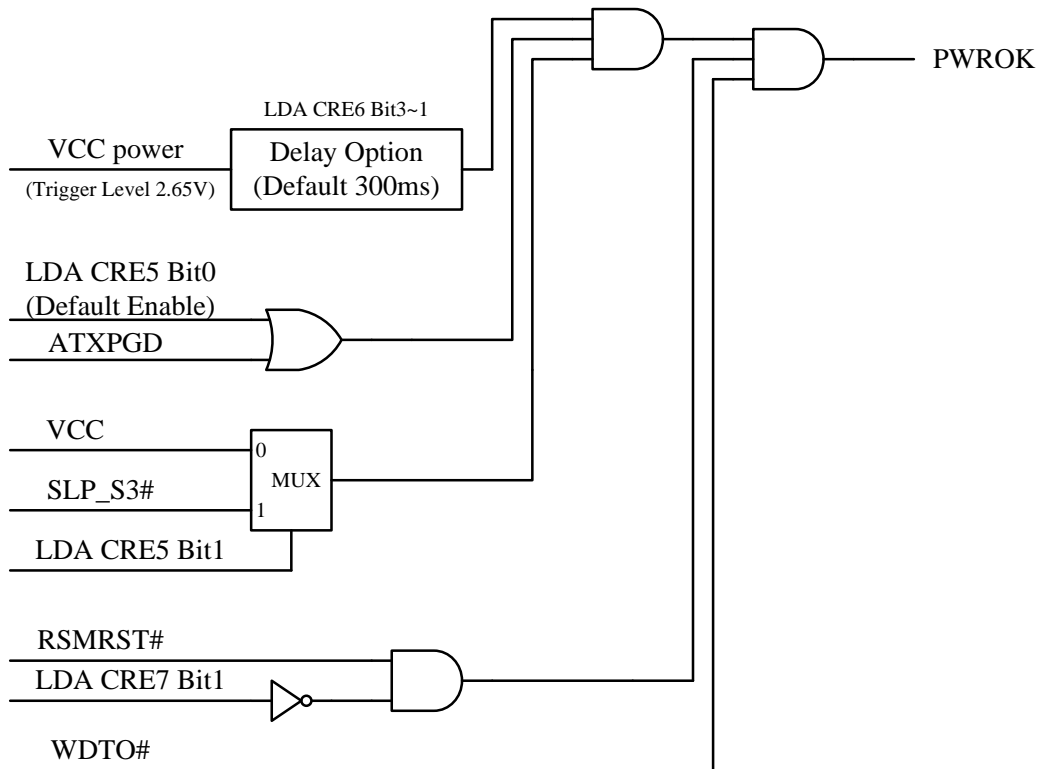

Figure 6-6 PWROK Block Diagram

6.6 Front Panel LEDs

NCT6102D / NCT6106D supports two LED control to some GPIO pins – GRN_LED and YLW_LED.

For dual-color LED application:

- (1)GRN_LED pin is connected to a 470ohm resistor to 5VSB, and the cathode of the green LED and the anode of the yellow LED.
- (2)YLW_LED pin is connected to a 470ohm resistor to 5VSB, and the cathode of the yellow LED and the anode of the green LED.

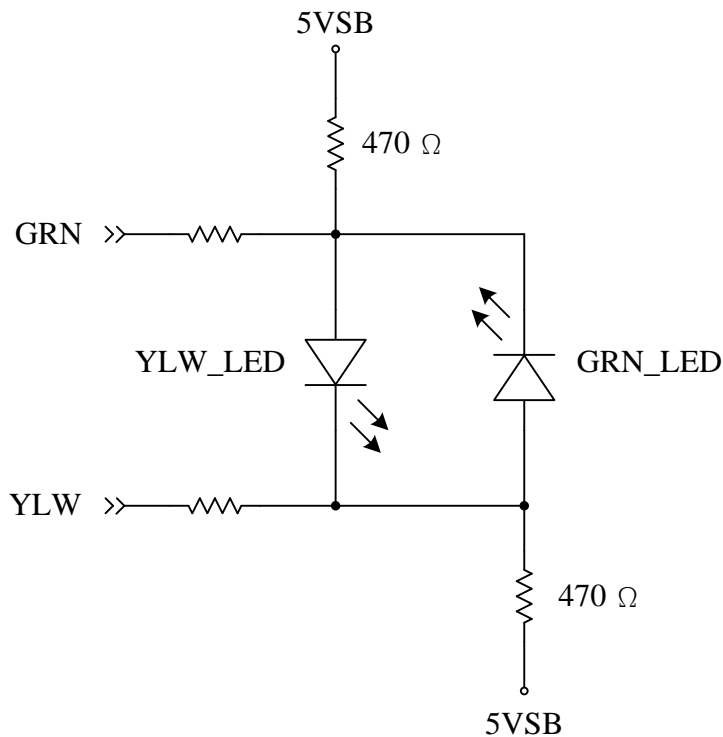

Figure 6-7 Illustration of Dual Color LED application

GRN_LED and YLW_LED pins are designed to show currently power states. There are Manual Mode and Automatic Mode:

6.6.1 Automatic Mode

Power state is S0 or S1: GRN_LED will be asserted by default.

Power state is S3: YLW_LED will be asserted by default.

Power state is S4 or S5: Both GRN_LED and YLW_LED will be de-asserted by default.

AUTO_EN	GRN_LED_RST (YLW_LED_RST)	Pwr State	SLP_S3#	SLP_S5#	GRN_LED	YLW_LED
1	X	S0,S1	1	1	GRN_BLK_FREQ	HIGH-Z
1	X	S3	0	1	HIGH-Z	YLW_BLK_FREQ

1	X	S4,S5	X	0	HIGH-Z	HIGH-Z
---	---	-------	---	---	--------	--------

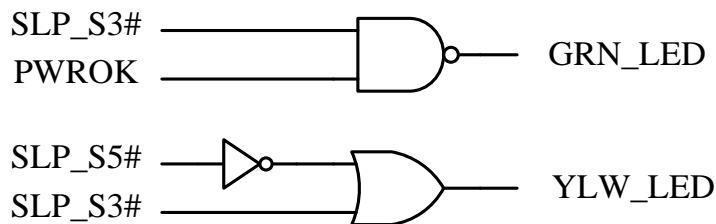

6.6.2 Manual Mode

AUTO_EN	GRN_LED_RST#	Pwr State	SLP_S3#	SLP_S5#	GRN_LED	YLW_LED
0	0	S0,S1	1	1	GRN_BLK_FREQ	YLW_BLK_FREQ
0	0	S3	0	1	HIGH-Z	HIGH-Z
0	0	S4,S5	X	0	HIGH-Z	HIGH-Z
0	1	S0,S1	1	1	GRN_BLK_FREQ	YLW_BLK_FREQ
0	1	S3	0	1	GRN_BLK_FREQ	YLW_BLK_FREQ
0	1	S4,S5	X	0	GRN_BLK_FREQ	YLW_BLK_FREQ

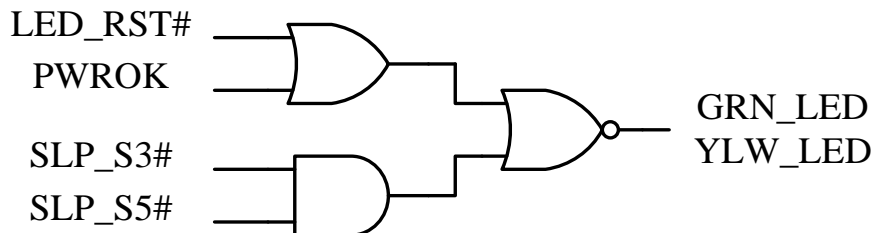

6.6.3 S0-S5 LED Blink Block Diagram

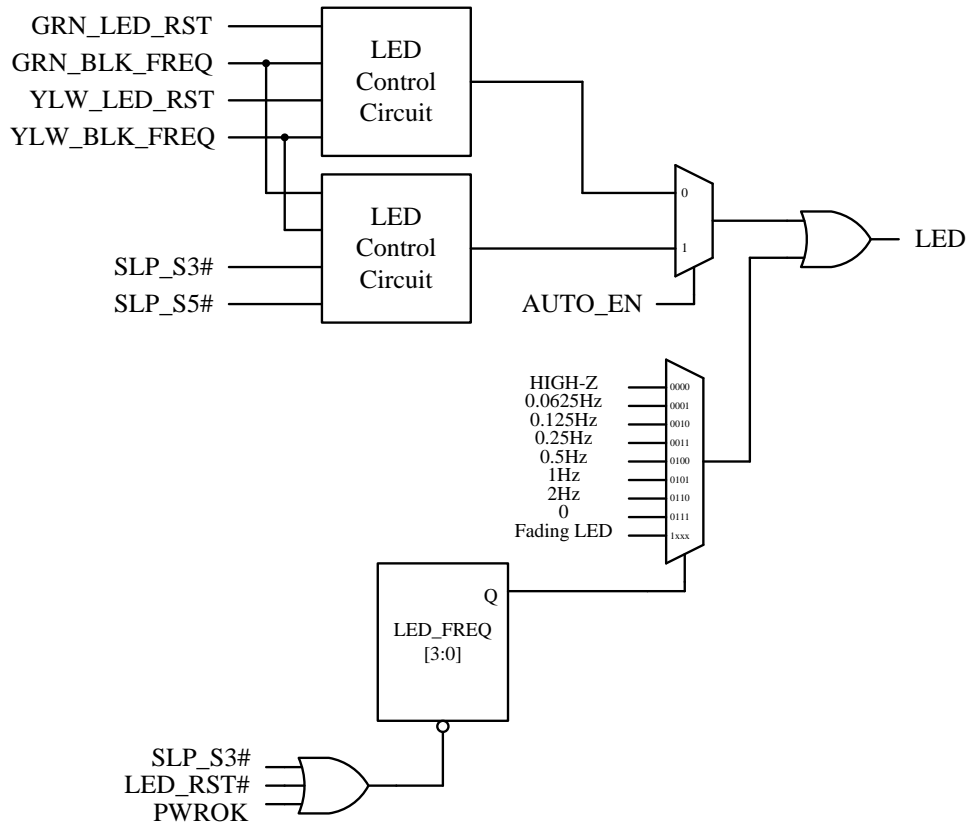

6.6.4 LED Pole (LED_POL)

Set to 0b, GRN_LED output is active low, as the following Figure (a)

Set to 1b, GRN_LED output is active high, as the following Figure (b)

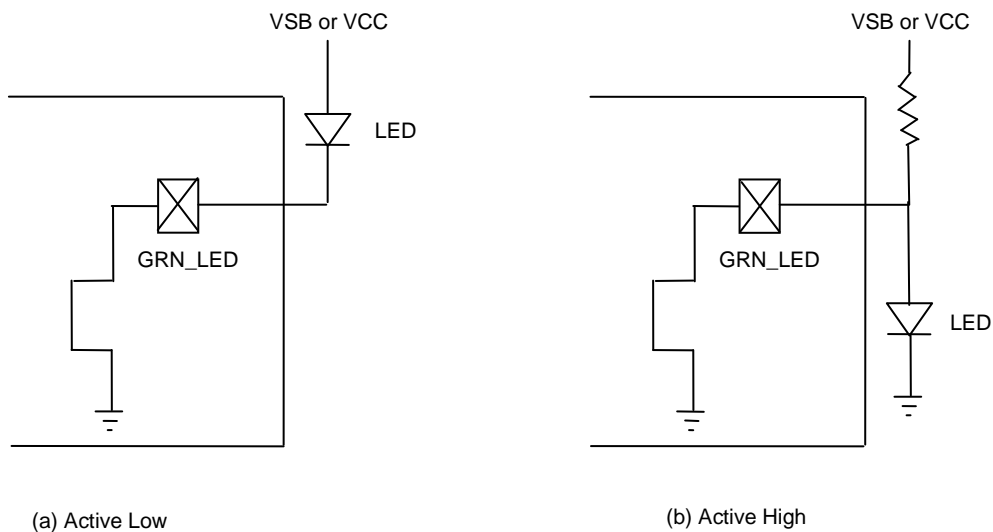

Figure 6-8 Illustration of LED polarity



6.6.5 Deeper Sleeping State Detect Function

These two LED pins could also be used to indicate if the system is in Deeper Sleeping State. For more detail, please refer to the section of Advanced Sleep State Control Function.

Enable_DEEP_S5	GRN_DEEPS#_Disable (YLW_DEEPS#_Disable)	Pwr State	GRN_LED	YLW_LED
1	0	DEEP_S5	DeepS5_GRN_BLK_FREQ	DeepS5_YLW_BLK_FREQ
1	1	DEEP_S5	HIGH-Z	HIGH-Z
0	X	S0~S5	S0~S5 behavior	S0~S5 behavior

Enable_DEEP_S3	GRN_DEEPS#_Disable (YLW_DEEPS#_Disable)	Pwr State	GRN_LED	YLW_LED
1	0	DEEP_S3	DeepS3_GRN_BLK_FREQ	DeepS3_YLW_BLK_FREQ
1	1	DEEP_S3	HIGH-Z	HIGH-Z
0	X	S0~S5	S0~S5 behavior	S0~S5 behavior

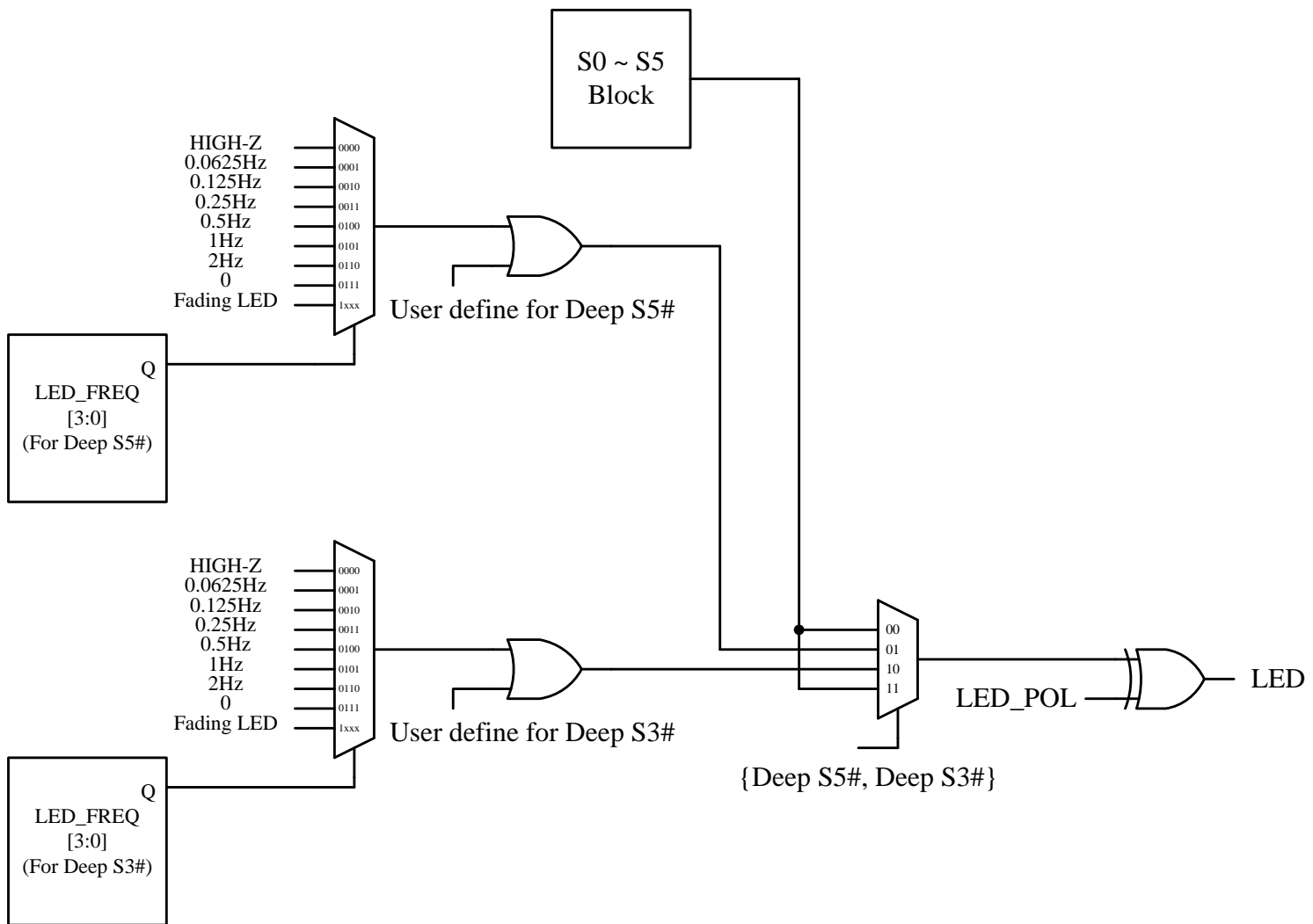

6.7 Advanced Sleep State Control (ASSC) Function

Advanced Sleep State Control (ASSC) Function is used to control the system power at S3 or S5 state. The purpose of this function is to provide a method to reduce power consumption at S3 or S5 state. This function is disabled by default. When VCC power is first supplied, BIOS can program the register to enable ASSC Function. The register is powered by 3VSB_IO and some is powered by VBAT. The related registers are located at Logic Device 16 CRE0h ~ CRE3h.

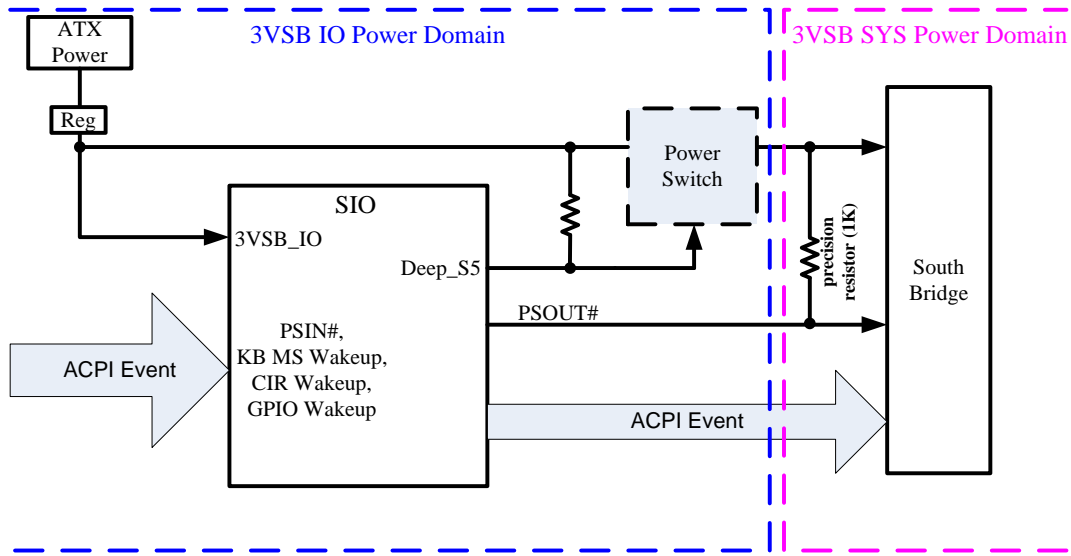
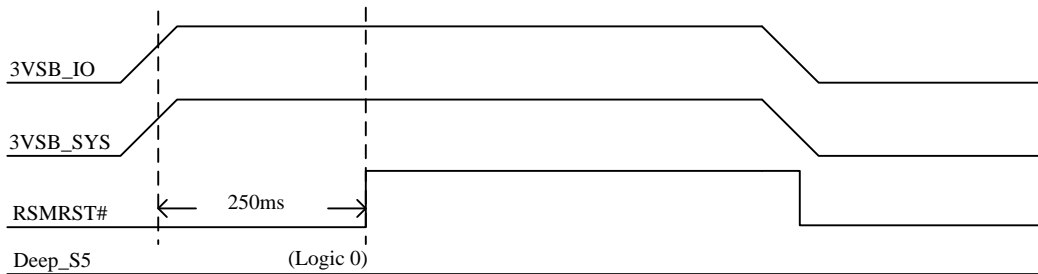

Figure 6-9 ASSC Application Diagram

6.7.1 When ASSC is disabled



When ASSC is disabled, ACPI function is as same as the normal ACPI behavior.

6.7.2 When ASSC is enabled (Enter into Deeper Sleeping State)

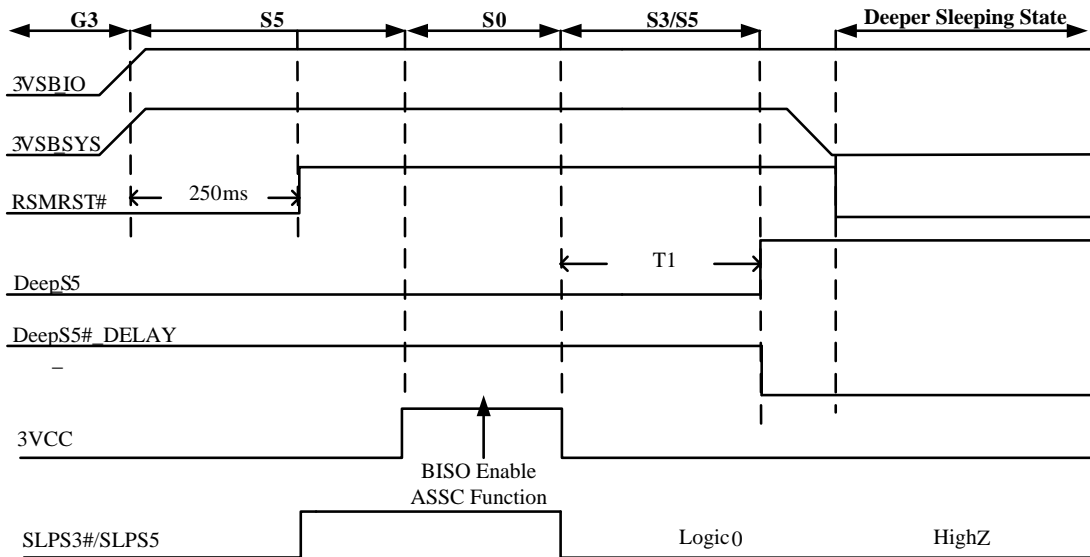

When the first time AC plug in and enter into S0 State, BIOS can enable ASSC Function (DeepS3 or DeepS5), when the system enters S3/S5 state, the pin DEEP_S5 will be asserted after pre configuration delay time (power_off_dly_time, LD16 CRE2) to make the system entering the “Deeper Sleeping State (DSS)” where system’s VSB power is cut off. When pin DEEP_S5 asserts, the pin RSMRST# will de-assert by detecting PSOUT# signal (monitor 3VSB SYS Power).

6.7.3 When ASSC is enabled (Exit Deeper Sleeping State)

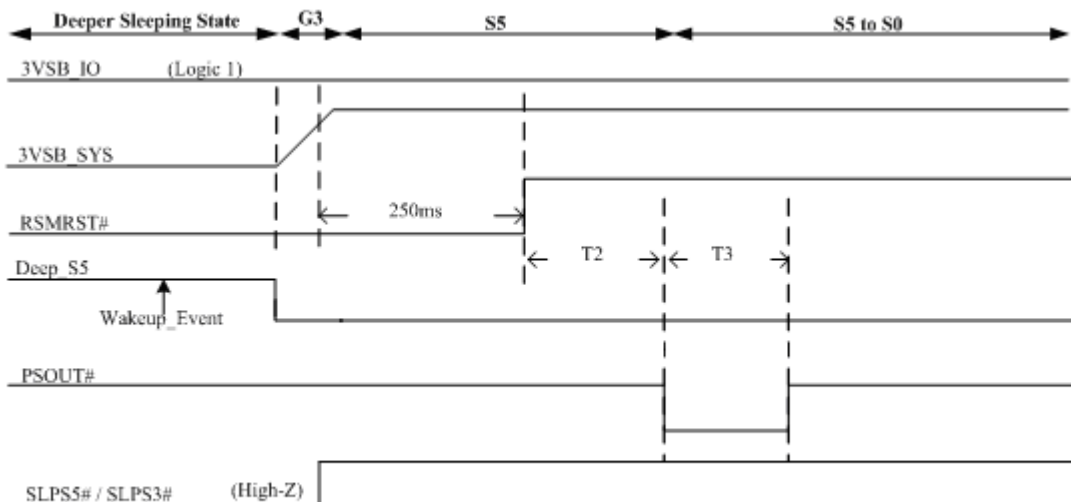

When any Wakeup Event (PSIN#, KB MS Wakeup, CIR wakeup, GPIO Wakeup) happened, pin DEEP_S5 will be de-asserted to turn on the VSB power to the system. The pin RSMRST# will de-assert when 3VSB_SYS power reach valid voltage. And then the pin PSOUT# will issue a low pulse (T3) turn on the system after T2 time (wakeup



delay time, LD16 CRE0). The PSOUT# low pulse is also programmable (LD16 CRE1). The T4 time is the delay from Deep_S5 ds-assert to Deeo_S5#_DELAY de-assert.

6.7.4 SLP_S5#_LATCH Control Function

SLP_S5#_LATCH control signal is similar to SLPS5# signal. When System is at S0 ~ S5 state, SLP_S5#_LATCH follows the SLPS5# signal. When system is at DeepS5 State, SLP_S5#_LATCH will keep low state till system returns to S0 state. When system is at DeepS3 State, SLP_S5#_LATCH will keep high till system returns to S0 state. Please see the following timing diagram.

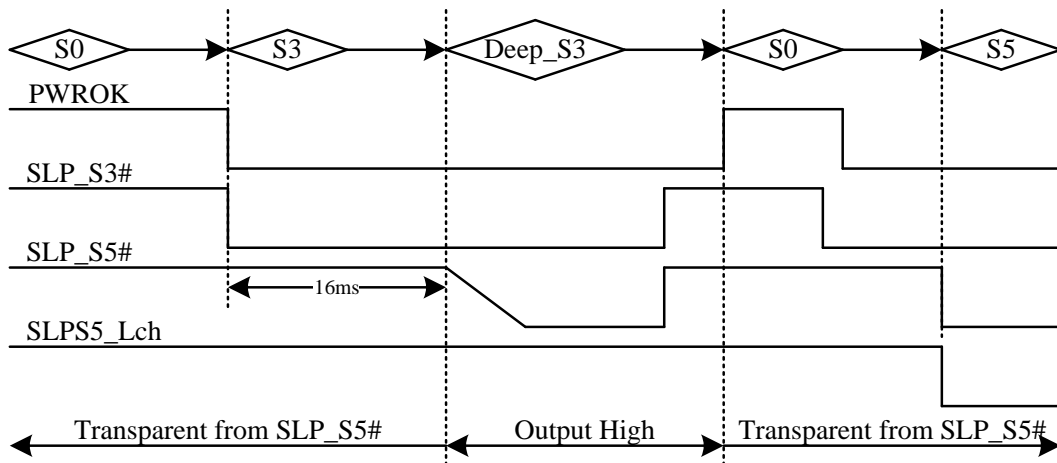

6.8 Intel DSW Function

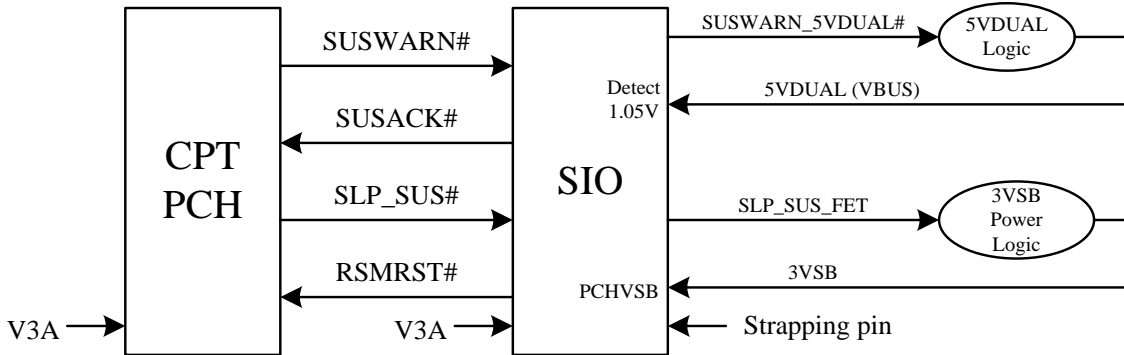

6.8.1 Enter DSW State timing diagram

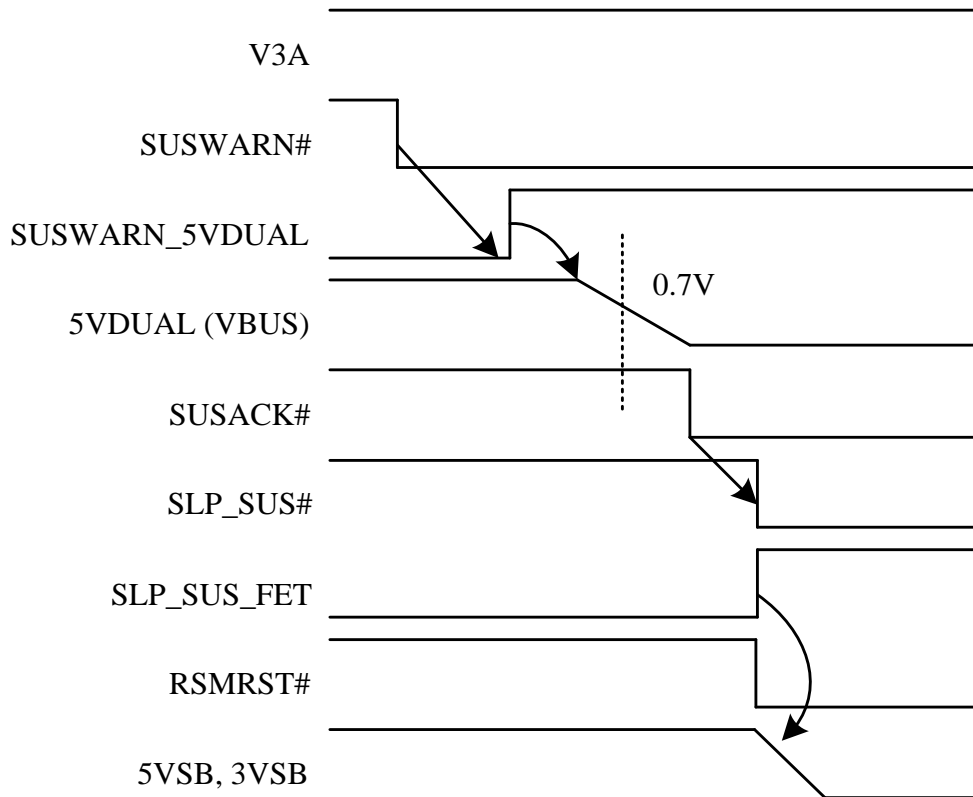

6.8.2 Exit DSW State timing diagram

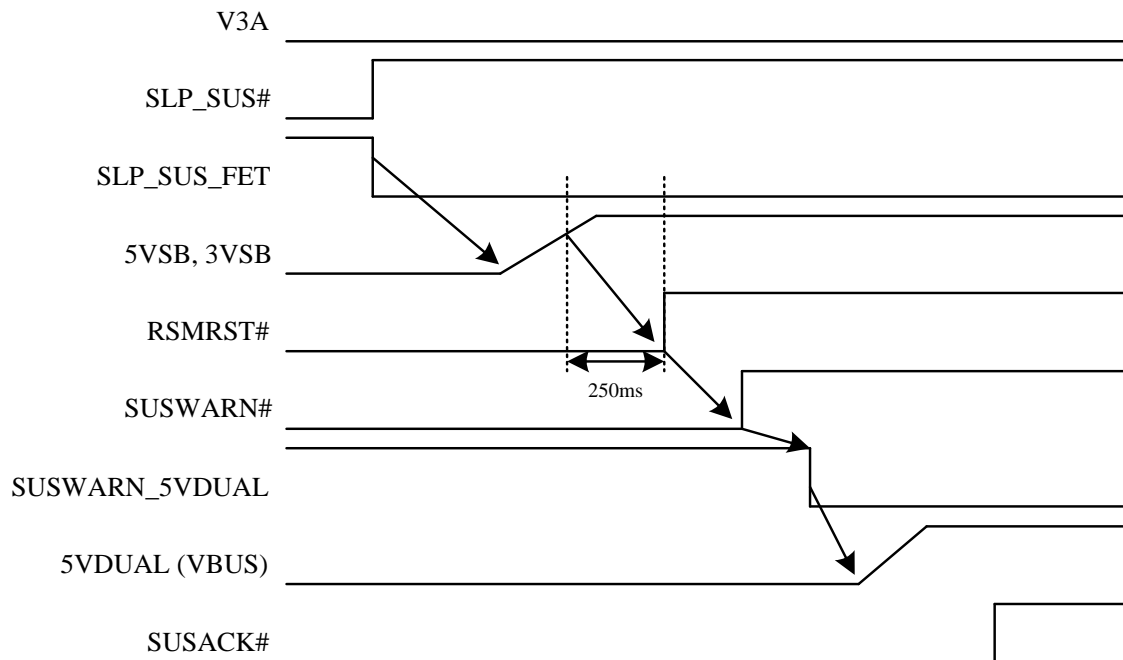

6.8.3 Application Circuit

The NCT6102D / NCT6106D can not only provide SIO Deep S5/S3 function, but Intel DSW function. The application circuit should follow the guide below:

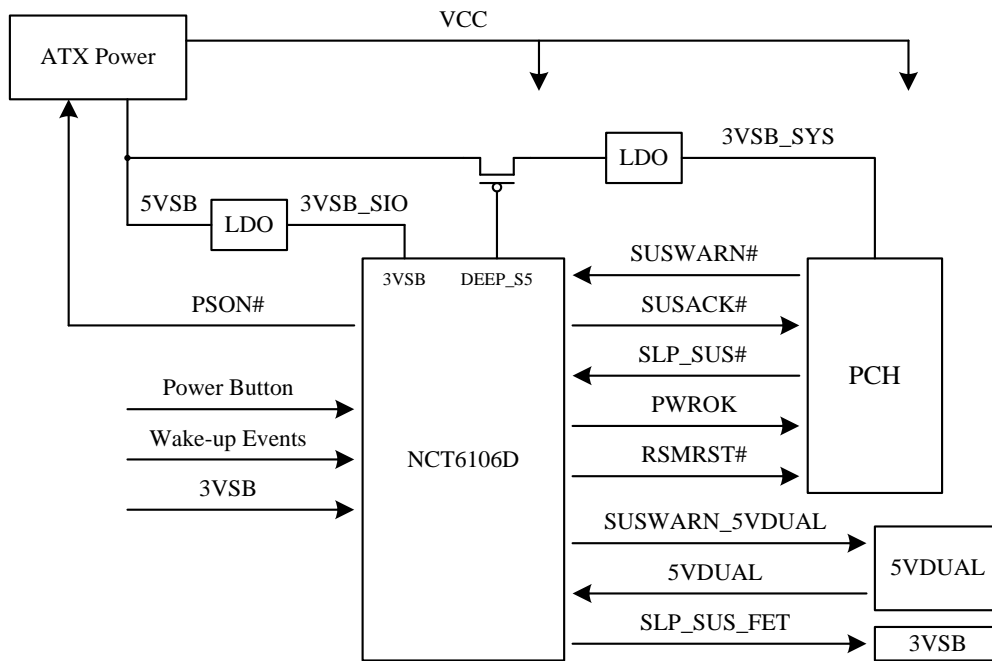

7. CONFIGURATION REGISTER ACCESS PROTOCOL

The NCT6102D / NCT6106D uses a special protocol to access configuration registers to set up different types of configurations. The NCT6102D / NCT6106D has a total of 17 Logical Devices (from Logical Device 0 to Logical Device 16 with the exception of Logical Device 4 & C for backward compatibility) corresponding to fourteen individual functions: FDC (Logical Device 0), PRT (Logical Device 1), UARTA (Logical Device 2), UARTB (Logical Device 3), KBC (Logical Device 5), CIR (Logical Device 6), GPIO (Logical Device 7), GPIO & WDT1 (Logical Device 8), GPIO (Logical Device 9), ACPI (Logical Device A), HM & LED (Logical Device B), WDT2 (Logical Device D), CIR WAKE-UP (Logical Device E), GPIO (Logical Device F), UARTC (Logical Device 10), UARTD (Logical Device 11),UARTE (Logical Device 12), UARTF (Logical Device 13), PORT80 & IR (Logical Device 14), FADING LED (Logical Device 15) and DEEP SLEEP (Logical Device 16).

It would require a large address space to access all of the logical device configuration registers if they were mapped into the normal PC address space. The NCT6102D / NCT6106D, then, maps all the configuration registers through two I/O addresses (2Eh/2Fh or 4Eh/4Fh) set at power on by the strap pin 2E_4E_SEL. The two I/O addresses act as an index/data pair to read or write data to the Super I/O. One must write an index to the first I/O address which points to the register and read or write to the second address which acts as a data register.

An extra level of security is added by only allowing data updates when the Super I/O is in a special mode, called the Extended Function Mode. This mode is entered by two successive writes of 87h data to the first I/O address. This special mode ensures no false data can corrupt the Super I/O configuration during a program runaway.

There are a set of global registers located at index 0h – 2Fh, containing information and configuration for the entire chip.

The method to access the control registers of the individual logical devices is straightforward. Simply write the desired logical device number into the global register 07h. Subsequent accesses with indexes of 30h or higher are directly to the logical device registers.

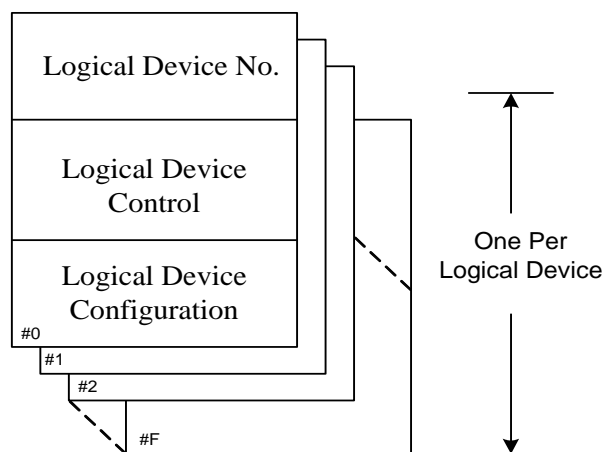

Figure 7-1 Structure of the Configuration Register

Table 7-1 Devices of I/O Base Address

LOGICAL DEVICE NUMBER	FUNCTION	I/O BASE ADDRESS
0	FDC	100h ~ FF8h
1	PRT	100h ~ FF8h
2	UARTA	100h ~ FF8h
3	UARTB	100h ~ FF8h
4	Reserved	
5	KBC	100h ~ FFFh
6	CIR	100h ~ FF8h
7	GPIO	Reserved
8	GPIO, WDT1	Reserved
9	GPIO	Reserved
A	ACPI	Reserved
B	HM, LED	100h ~ FFEh
C	Reserved	
D	WDT2	Reserved
E	CIR WAKE-UP	100h ~ FF8h
F	GPIO	Reserved
10	UARTC	100h ~ FF8h
11	UARTD	100h ~ FF8h
12	UARTE	100h ~ FF8h
13	UARTF	100h ~ FF8h
14	PORT80, IR	100h ~ FF8h
15	FADING LED	Reserved
16	DEEP SLEEP	Reserved

7.1 Configuration Sequence

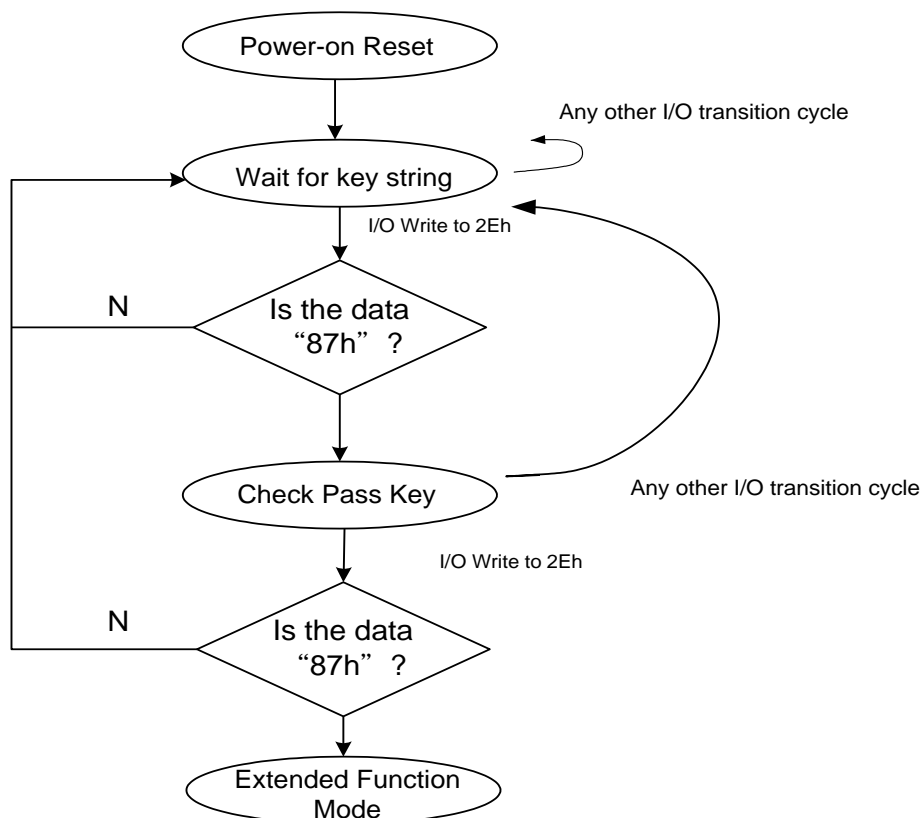

Figure 7-2 Configuration Register

To program the NCT6102D / NCT6106D configuration registers, the following configuration procedures must be followed in sequence:

- (1). Enter the Extended Function Mode.
- (2). Configure the configuration registers.
- (3). Exit the Extended Function Mode.

7.1.1 Enter the Extended Function Mode

To place the chip into the Extended Function Mode, two successive writes of 0x87 must be applied to Extended Function Enable Registers (EFERs, i.e. 2Eh or 4Eh).

7.1.2 Configure the Configuration Registers

The chip selects the Logical Device and activates the desired Logical Devices through Extended Function Index Register (EFIR) and Extended Function Data Register (EFDR). The EFIR is located at the same address as the EFER, and the EFDR is located at address (EFIR+1).

First, write the Logical Device Number (i.e. 0x07) to the EFIR and then write the number of the desired Logical Device to the EFDR. If accessing the Chip (Global) Control Registers, this step is not required.



Secondly, write the address of the desired configuration register within the Logical Device to the EFIR and then write (or read) the desired configuration register through the EFDR.

7.1.3 Exit the Extended Function Mode

To exit the Extended Function Mode, writing 0xAA to the EFER is required. Once the chip exits the Extended Function Mode, it is in the normal running mode and is ready to enter the configuration mode.

7.1.4 Software Programming Example

The following example is written in Intel 8086 assembly language. It assumes that the EFER is located at 2Eh, so the EFIR is located at 2Eh and the EFDR is located at 2Fh. If the HEFRAS (CR [26h] bit 6 showing the value of the strap pin at power on) is set, 2Eh can be directly replaced by 4Eh and 2Fh replaced by 4Fh.

This example programs the configuration register F0h (clock source) of logical device 1 (UART A) to the value of 3Ch (24MHz). First, one must enter the Extended Function Mode, then setting the Logical Device Number (Index 07h) to 01h. Then program index F0h to 3Ch. Finally, exit the Extended Function Mode.

```

;-----
; Enter the Extended Function Mode
;-----
MOV  DX, 2EH
MOV  AL, 87H
OUT  DX, AL
OUT  DX, AL
;-----
; Configure Logical Device 1, Configuration Register CRF0
;-----
MOV  DX, 2EH
MOV  AL, 07H
OUT  DX, AL      ; point to Logical Device Number Reg.
MOV  DX, 2FH
MOV  AL, 01H
OUT  DX, AL      ; select Logical Device 1
;
MOV  DX, 2EH
MOV  AL, F0H
OUT  DX, AL      ; select CRF0
MOV  DX, 2FH
MOV  AL, 3CH
OUT  DX, AL      ; update CRF0 with value 3CH
;-----
; Exit the Extended Function Mode
;-----
MOV  DX, 2EH
MOV  AL, AAH
OUT  DX, AL

```

8. HARDWARE MONITOR

8.1 General Description

The NCT6102D / NCT6106D monitors several critical parameters in PC hardware, including power supply voltages, fan speeds, and temperatures, all of which are very important for a high-end computer system to work stably and properly. In addition, proprietary hardware reduces the amount of programming and processor intervention to control cooling fan speeds, minimizing ambient noise and maximizing system temperature and reliability.

The NCT6102D / NCT6106D can simultaneously monitor all of the following inputs:

- Eight analog voltage inputs (five internal voltages CPUVCORE, VBAT, 3VSB, 3VCC and AVCC; three external voltage inputs)
- Three fan tachometer inputs
- Three remote temperatures, using either a thermistor or from the CPU thermal diode (voltage or Current Mode measurement method)
- One case-open detection signal.

These inputs are converted to digital values using the integrated, eight-bit analog-to-digital converter (ADC).

In response to these inputs, the NCT6102D / NCT6106D can generate the following outputs:

- Three PWM (pulse width modulation) or DC fan outputs for the fan speed control
- SMI#
- OVT# signals for system protection events

The NCT6102D / NCT6106D provides hardware access to all monitored parameters through the LPC or I²C interface and software access through application software, such as Nuvoton's Hardware Doctor™, or BIOS.

The rest of this section introduces the various features of the NCT6102D / NCT6106D hardware-monitor capability. These features are divided into the following sections:

- Access Interfaces
- Analog Inputs
- Fan Speed Measurement and Control
- Smart Fan Control
- SMI# interrupt mode
- OVT# interrupt mode
- Registers and Value RAM

8.2 Access Interfaces

The NCT6102D / NCT6106D provides two interfaces, LPC and I²C, for the microprocessor to read or write the internal registers of the hardware monitor.

8.3 LPC Interface

The internal registers of the hardware monitor block are accessible through two separate methods on the LPC bus. The first set of registers, which primarily enable the block and set its address in the CPU I/O address space are accessed by the Super I/O protocol described in Chapter 7 at address 2Eh/2Fh or 4Eh/4Fh. The bulk of the functionality and internal registers of this block are accessed from an index/data pair of CPU I/O addresses. The

standard locations are usually 295h/296h and are set by CR[60h]&CR[61h] accessed using the Super I/O protocol as described in Chapter 7.

Due to the number of internal register, it is necessary to separate the register sets into “banks” specified by register 4Eh. The structure of the internal registers is shown in the following figure.

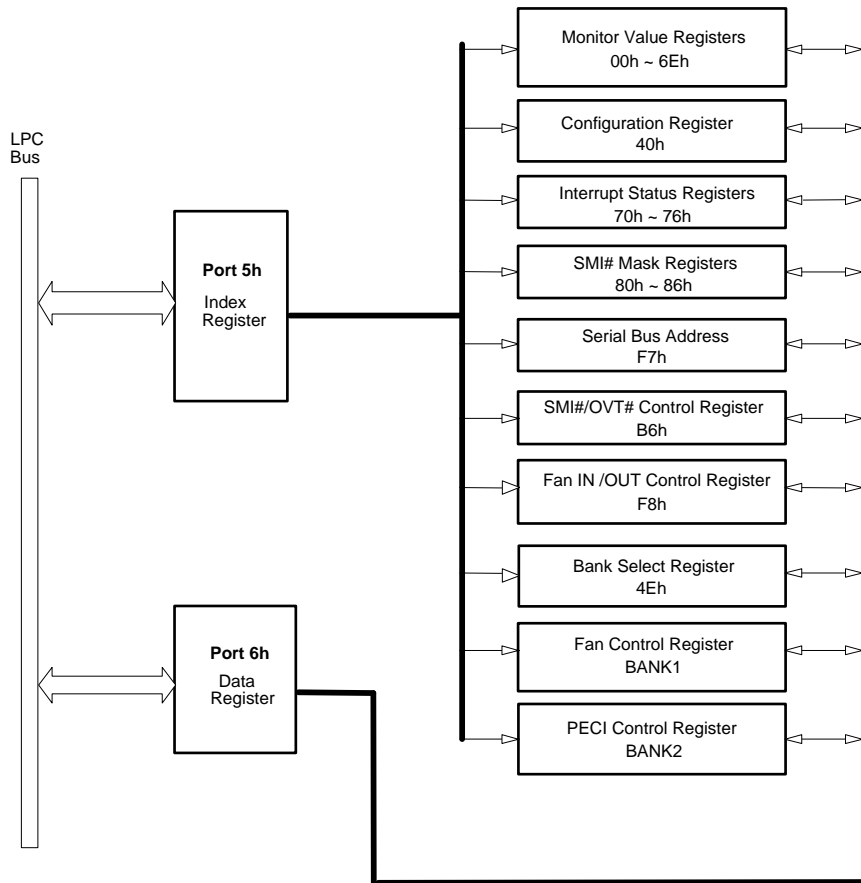

Figure 8-1 LPC Bus' Reads from / Write to Internal Registers

8.4 I²C interface

The I²C interface is a second, serial port into the internal registers of the hardware monitor function block. The interface is totally compatible with the industry-standard I²C specification, allowing external components that are also compatible to read the internal registers of the NCT6102D / NCT6106D hardware monitor and control fan speeds. The address of the I²C peripheral is set by the register located at index 48h (which is accessed by the index/data pair at I/O address typically at 295h/296h)

The two timing diagrams below illustrate how to use the I²C interface to write to an internal register and how to read the value in an internal register, respectively.

(a) Serial bus write to internal address register followed by the data byte

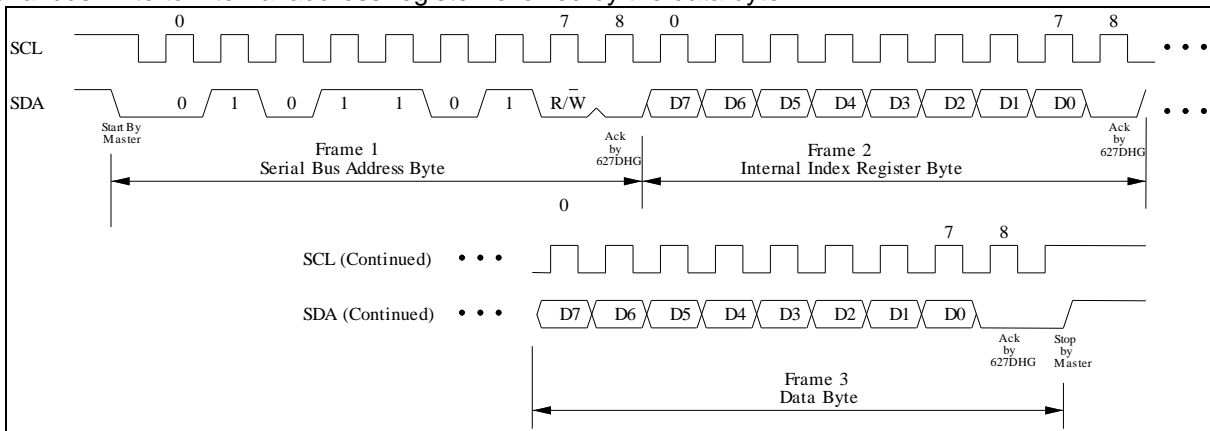

Figure 8-2 Serial Bus Write to Internal Address Register Followed by the Data Byte

(b) Serial bus read from a register

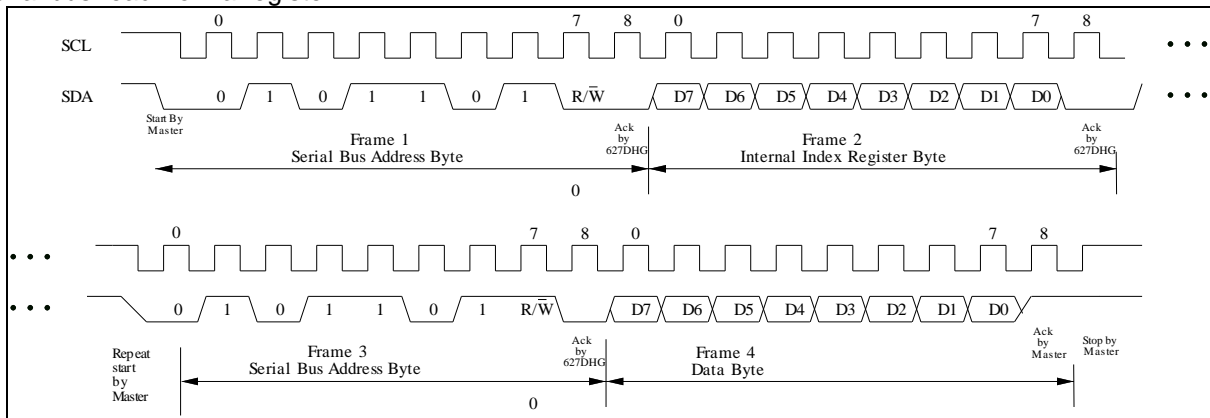

Figure 8-3 Serial Bus Read from Internal Address Register

8.5 Analog Inputs

The nine analog inputs of the hardware monitor block connect to an 8-bit Analog to Digital Converter (ADC) and consist of 4 general-purpose inputs connected to external device pins (VIN0 – VIN2) and five internal signals connected to the power supplies (CPUVCORE, AVCC, VBAT, 3VSB and 3VCC). All inputs are limited to a maximum voltage of 2.048V due to an internal setting of 8mV LSB (256 steps x 8mV = 2.048V). All inputs to the ADC must limit the maximum voltage by using a voltage divider. The power supplies have internal resistors, while the external pins require outside limiting resistors as described below.

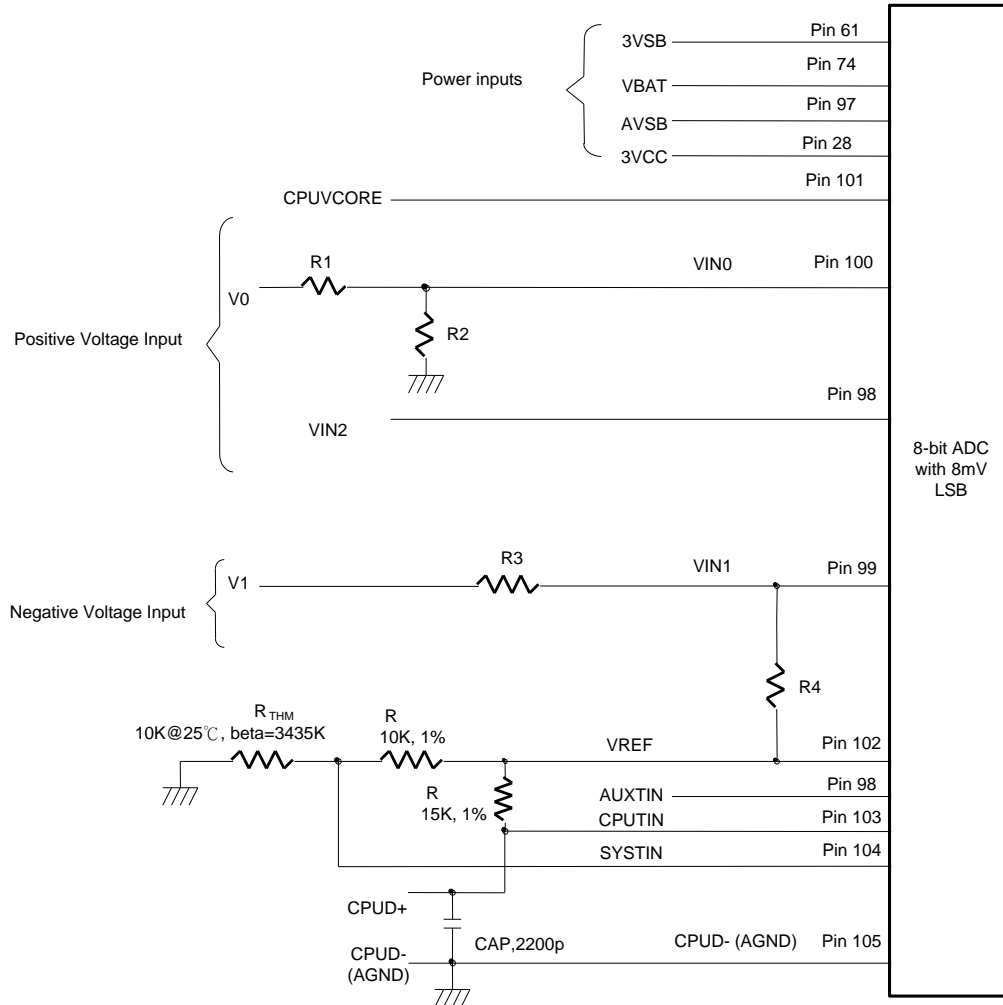

Figure 8-4 Analog Inputs and Application Circuit of the NCT6102D / NCT6106D

As illustrated in the figure above, other connections may require some external circuits. The rest of this section provides more information about voltages outside the range of the 8-bit ADC, CPU Vcore voltage detection, and temperature sensing.

8.5.1 Voltages Over 2.048 V or Less Than 0 V

Input voltages greater than 2.048 V should be reduced by an external resistor divider to keep the input voltages in the proper range. For example, input voltage V_0 (+12 V) should be reduced before it is connected to VIN0 according to the following equation:

$$VIN0 = V_0 \times \frac{R_2}{R_1 + R_2}$$

R1 and R2 can be set to 56 K Ω and 10 K Ω , respectively, to reduce V_0 from +12 V to less than 2.048 V.

All the internal inputs of the ADC, AVCC, VBAT, 3VSB and 3VCC utilize an integrated voltage divider with both resistors equal to 34K Ω , yielding a voltage one half of the power supply. Since one would expect a worst-case 10% variation or a 3.63V maximum voltage, the input to the ADC will be 1.815V, well within the maximum range.

$$V_{in} = VCC \times \frac{34K\Omega}{34K\Omega + 34K\Omega} \cong 1.65V, \text{ where } VCC \text{ is set to } 3.3V$$

The CPUVCORE pin feeds directly into the ADC with no voltage divider since the nominal voltage on this pin is only 1.2V.

Negative voltages are handled similarly, though the equation looks a little more complicated. For example, negative voltage V_1 (-12V) can be reduced according to the following equation:

$$VIN1 = (V_1 - 2.048) \times \frac{R_4}{R_3 + R_4} + 2.048, \text{ where } V_1 = -12$$

R3 and R4 can be set to 232 K Ω and 10 K Ω , respectively, to reduce negative input voltage V_1 from -12 V to less than 2.048 V. Note that R4 is referenced to VREF, or 2.048V instead of 0V to allow for more dynamic range. This is simply good analog practice to yield the most precise measurements.

Both of these solutions are illustrated in the figure above.

8.5.2 Voltage Data Format

The data format for voltage detection is an eight-bit value, and each unit represents an interval of 8 mV.

$$\text{Detected Voltage} = \text{Reading} * 0.008 \text{ V}$$

If the source voltage was reduced by a voltage divider, the detected voltage value must be scaled accordingly.

8.5.2.1. Voltage Reading

NCT6102D / NCT6106D has 8 voltage reading:

	3VCC	AVCC	3VSB	VBAT	
Voltage reading	Bank0, Index03	Bank0, Index02	Bank0, Index07	Bank0, Index08	
	CPUVCORE	VIN0	VIN1	VIN2	
Voltage reading	Bank0, Index00	Bank0, Index01	Bank0, Index04	Bank0, Index05	

8.5.3 Temperature Data Format

The data format for sensors SYSTIN, CPUTIN and AUXTIN is 9-bit, two's-complement. This is illustrated in the table below. There are two sources of temperature data: external thermistors or thermal diodes.

Table 8-1 Temperature Data Format

TEMPERATURE	8-BIT DIGITAL OUTPUT		9-BIT DIGITAL OUTPUT	
	8-BIT BINARY	8-BIT HEX	9-BIT BINARY	9-BIT HEX
+125°C	0111,1101	7Dh	0,1111,1010	0FAh
+25°C	0001,1001	19h	0,0011,0010	032h
+1°C	0000,0001	01h	0,0000,0010	002h
+0.5°C	-	-	0,0000,0001	001h
+0°C	0000,0000	00h	0,0000,0000	000h
-0.5°C	-	-	1,1111,1111	1FFh
-1°C	1111,1111	FFh	1,1111,1110	1FFh
-25°C	1110,0111	E7h	1,1100,1110	1Ceh
-55°C	1100,1001	C9h	1,1001,0010	192h

8.5.3.1. Monitor Temperature from Thermistor

External thermistors should have a β value of 3435K and a resistance of 10 K Ω at 25°C. As illustrated in the schematic above, the thermistor is connected in series with a 10-K Ω resistor and then connects to VREF. The configuration registers to select a thermistor temperature sensor and the measurement method are found at Bank 3, 18h, and 19h.

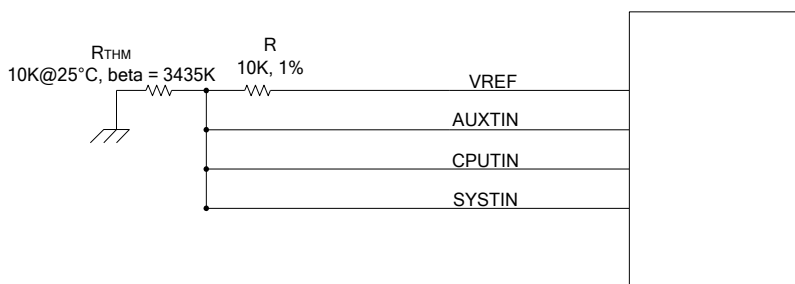

Figure 8-5 Monitoring Temperature from Thermistor

8.5.3.2. Monitor Temperature from Thermal Diode (Voltage Mode)

The thermal diode D- pin is connected to AGND, and the D+ pin is connected to the temperature sensor pin in the NCT6102D / NCT6106D. A 15-K Ω resistor is connected to VREF to supply the bias current for the diode, and the 2200-pF, bypass capacitor is added to filter high-frequency noise. The configuration registers to select a thermal diode temperature sensor and the measurement method are found at Bank 3, index 18h, and 19h.

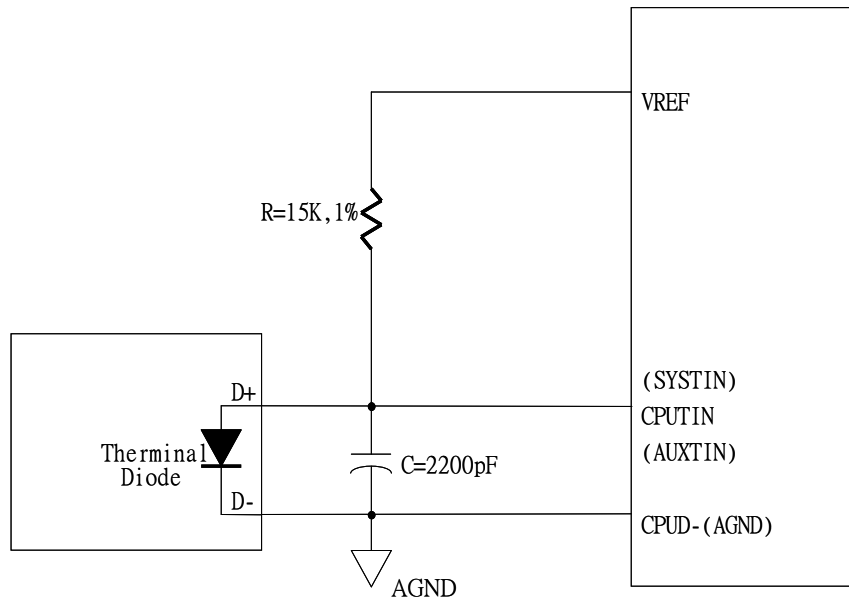

Figure 8-6 Monitoring Temperature from Thermal Diode (Voltage Mode)

8.5.3.3. Monitor Temperature from Thermal Diode (Current Mode)

The NCT6102D / NCT6106D can also sense the diode temperature through Current Mode and the circuit is shown in the following figure.

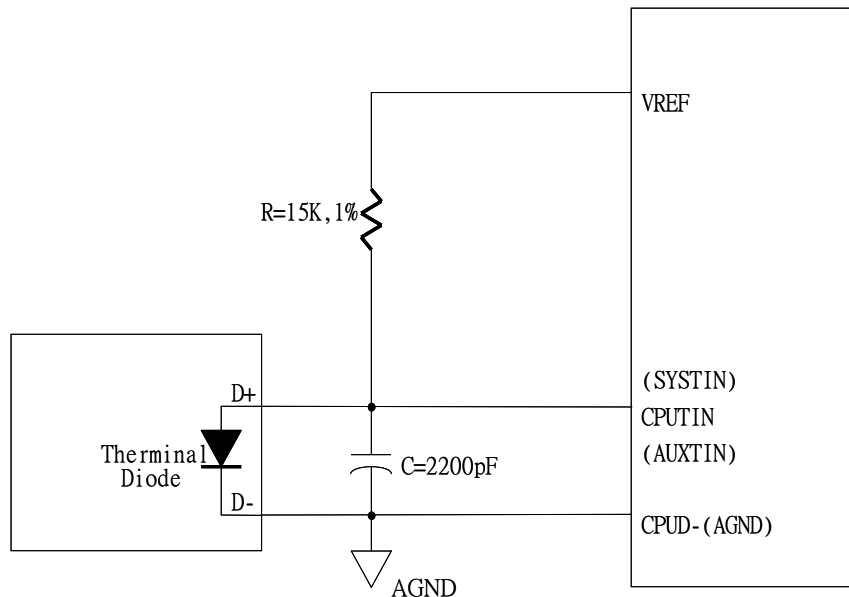

Figure 8-7 Monitoring Temperature from Thermal Diode (Current Mode)

The pin of processor D- is connected to CPUD- and the pin D+ is connected to temperature sensor pin in the NCT6102D / NCT6106D. A bypass capacitor $C=2200\text{pF}$ should be added to filter the high frequency noise. The configuration registers to select a thermal diode temperature sensor and the measurement method are found at Bank 3, 18h, and 19h.

8.5.3.4. Temperature Reading

NCT6102D / NCT6106D has 6 temperature reading can monitor different temperature sources (ex. SYSTIN, CPUTIN, AUXTIN, PECI...etc).

	SMIOVT1	SMIOVT2	SMIOVT3	SMIOVT4	SMIOVT5	SMIOVT6
Temperature source select	Bank0, indexB0 bit[4:0] default: SYSTIN	Bank0, indexB1 bit[4:0] default: CPUTIN	Bank0, indexB2 bit[4:0] default: AUXTIN	Bank0, indexB3 bit[4:0] default: SYSTIN	Bank0, indexB4 bit[4:0] default: SYSTIN	Bank0, indexB5 bit[4:0] default: SYSTIN
Temperature reading (2's complement)	Bank0, index10 & index16 bit0	Bank0, index11 & index16 bit1	Bank0, index12 & index16 bit2	Bank0, index13 & index16 bit3	Bank0, index14 & index16 bit4	Bank0, index15 & index16 bit5

8.6 PECCI

PECCI (Platform Environment Control Interface) is a new digital interface to read the CPU temperature of Intel® CPUs. With a bandwidth ranging from 2 Kbps to 2 Mbps, PECCI uses a single wire for self-clocking and data transfer. By interfacing to the Digital Thermal Sensor (DTS) in the Intel® CPU, PECCI reports a negative temperature (in counts) relative to the processor's temperature at which the thermal control circuit (TCC) is activated. At the TCC Activation temperature, the Intel CPU will operate at reduced performance to prevent the device from thermal damage.

PECCI is one of the temperature sensing methods that the NCT6102D / NCT6106D supports. The NCT6102D / NCT6106D contains a PECCI master and reads the CPU PECCI temperature. The CPU is a PECCI client.

The PECCI temperature values returning from the CPU are in "counts" which are approximately linear in relation to changes in temperature in degrees centigrade. However, this linearity is approximate and cannot be guaranteed over the entire range of PECCI temperatures. For further information, refer to the PECCI specification. All references to "temperature" in this section are in "counts" instead of "°C".

Figure 8-8 PECCI Temperature shows a typical fan speed (PWM duty cycle) and PECCI temperature relationship.

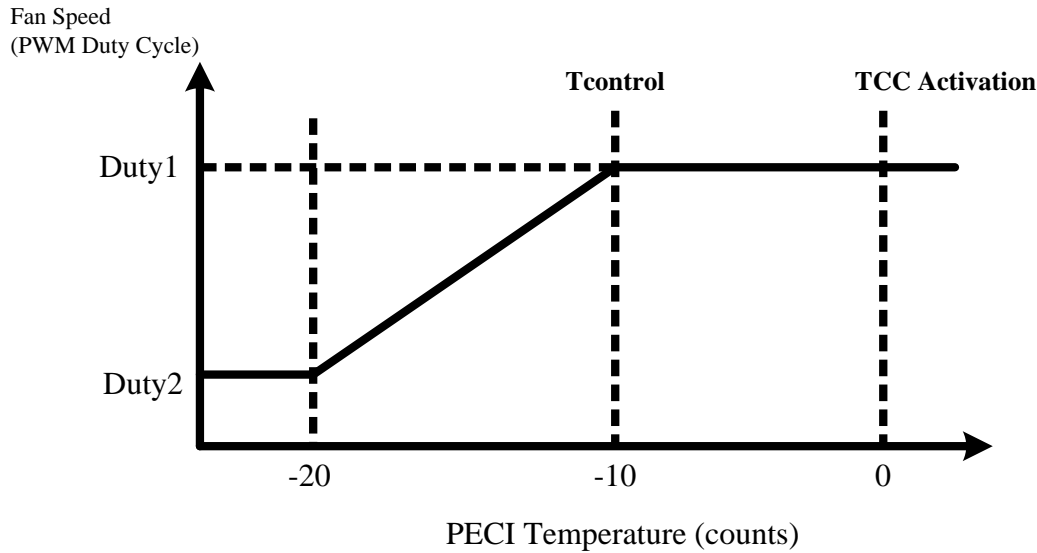

Figure 8-8 PECI Temperature

In this illustration, when PECI temperature is -20, the PWM duty cycle for fan control is at Duty2. When CPU is getting hotter and the PECI temperature is -10, the PWM duty cycle is at Duty1.

At Tcontrol PECI temperature, the recommendation from Intel is to operate the CPU fan at full speed. Therefore Duty1 is 100% if this recommendation is followed. The value of Tcontrol can be obtained by reading the related Machine Specific Register (MSR) in the Intel CPU. The Tcontrol MSR address is usually in the BIOS Writer's guide for the CPU family in question. Refer to the relevant CPU documentation from Intel for more information. In this example, Tcontrol is -10.

When the PECI temperature is below -20, the duty cycle is fixed at Duty2 to maintain a minimum (and constant) RPM for the CPU fan.

NCT6102D / NCT6106D's fan control circuit can only accept positive real-time temperature inputs and limits setting (in Smart Fan™ mode). The device provides offset registers to 'shift' the negative PECI readings to positive values otherwise the fan control circuit will not function properly. The offset registers are the Tbase registers located at Bank2, Index04h for PECI_BASE0; Bank2, Index05h for PECI_BASE1; separately. All default values of these Tbase registers are 8'h00. These registers should be programmed with (positive) values so that the resultant value (Tbase + PECI) is always positive. The unit of the Tbase register contents is "count" to match that of PECI values. The resultant value (Tbase + PECI) should not be interpreted as the "temperature" (whether in count or °C) of the PECI client (CPU).

Figure 8-9 Temperature and Fan Speed Relation after Tbase Offset shows the temperature/fan speed relationship after Tbase offsets are applied (based on Figure 8-8 PECI Temperature). This view is from the perspective of the NCT6102D / NCT6106D fan control circuit.

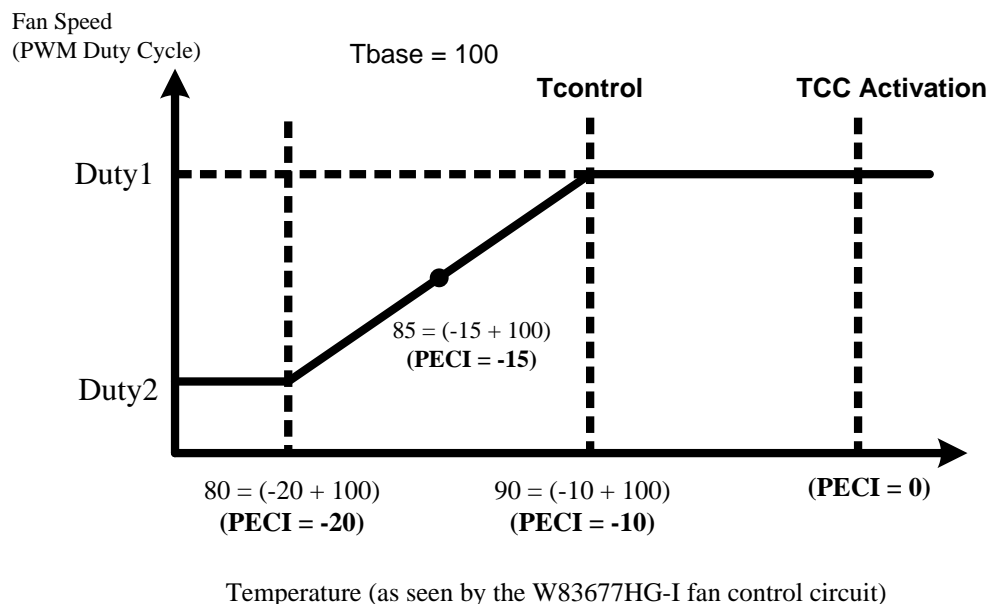

Figure 8-9 Temperature and Fan Speed Relation after Tbase Offsets

Assuming Tbase is set to 100 and the PECI temperature is -15, the real-time temperature value to the fan control circuit will be 85 (-15 + 100). The value of 55 (hex) will appear in the relevant real-time temperature register.

While using Smart Fan control function of NCT6102D / NCT6106D, BIOS/software must include Tbase in determining the thresholds (limits). In this example, assuming Tcontrol is -10 and Tbase is set to 100⁽¹⁾, the threshold temperature value corresponding to the "100% fan duty cycle" event is 90 (-10+100). The value of 5A (hex) should be written to the relevant threshold register.

Tcontrol is typically -10 to -20 for PECI-enabled CPUs. Base on that, a value of 85 ~100 for Tbase could be set for proper operation of the fan control circuit. This recommendation is applicable for most designs. In general, the concept presented in this section could be used to determine the optimum value of Tcontrol to match the specific application.

8.7 Fan Speed Measurement and Control

This section is divided into two parts, one to measure the speed and one to control the speed.

8.7.1 Fan Speed Reading

The fan speed reading is at

	FAN COUNT READING		FAN RPM READING	
	13-bit		16-bit	
	[12:5]	[4:0]	[15:8]	[7:0]
SYSFANIN	Bank0, Index20	Bank0, Index21	Bank0, Index30	Bank0, Index31
CPUFANIN	Bank0, Index22	Bank0, Index23	Bank0, Index32	Bank0, Index33
AUXFANIN	Bank0, Index24	Bank0, Index25	Bank0, Index34	Bank0, Index35

8.7.2 Fan Speed Calculation by Fan Count Reading

In 13-bit fan count reading, please read high byte first then low byte.

Fan speed RPM can be evaluated by the following equation:

$$RPM = \frac{1.35 \times 10^6}{Count}$$

8.7.3 Fan Speed Calculation by Fan RPM Reading

In 16-bit fan RPM reading, please read high byte first then low byte.

Fan speed RPM can be evaluated by translating 16-bit RPM reading from hexadecimal to decimal.

Register reading 0x09C4h = 2500 RPM

8.7.4 Fan Speed Control

The NCT6102D / NCT6106D has three output pins for fan control, each of which offers PWM duty cycle and DC voltage to control the fan speed. The output type (PWM or DC) of each pin is configured by Bank0 index F3h, bits 0 for SYSFANOUT, bits 1 for CPUFANOUT and bit 2 for AUXFANOUT.

Pin14 AUXFANOUT Function Output Enable controls by CR24 bit3 default disable.

	SYSFANOUT	CPUFANOUT	AUXFANOUT
Output Type Select	Bank0, IndexF3 bit0 0: PWM output(default) 1: DC output	Bank0, IndexF3 bit1 0: PWM output (default) 1: DC output	Bank0, IndexF3 bit2 0: PWM output (default) 1: DC output
Output Type Select (in PWM output)	CR24 bit6 0: open-drain (default)	CR24 bit5 0: open-drain (default)	CR24 bit4 0: open-drain (default)



		1: push-pull	1: push-pull	1: push-pull
PWM Output Frequency		Bank0, IndexF0	Bank0, IndexF1	Bank0, IndexF2
Fan Control Mode Select		Bank1, Index13, bit[7:4] 0h: Manual mode (def.) 1h: Thermal Cruise 2h: Speed Cruise 4h: SMART FAN IV	Bank1, Index23, bit[7:4] 0h: Manual mode(def.) 1h: Thermal Cruise 2h: Speed Cruise 4h: SMART FAN IV	Bank1, Index33, bit[7:4] 0h: Manual mode (def.) 1h: Thermal Cruise 2h: Speed Cruise 4h: SMART FAN IV
Output Value (write)	PWM output (Duty)	Bank1, Index19 bit[7:0]	Bank1, Index29 bit[7:0]	Bank1, Index39 bit[7:0]
	DC output (Voltage)	Bank1, Index19 bit[7:2]	Bank1, Index29 bit[7:2]	Bank1, Index39 bit[7:2]
Current Output Value (read)		Bank0, Index4A	Bank0, Index4B	Bank0, Index4C

For PWM, the duty cycle is programmed by eight-bit registers at Bank1 Index 19h for SYSFANOUT, Bank1 Index 29h for CPUFANOUT and Bank1 Index 39h for AUXFANOUT. The duty cycle can be calculated using the following equation:

$$\text{Duty cycle(\%)} = \frac{\text{Programmed 8-bit Register Value}}{255} \times 100\%$$

The default duty cycle is FFh, or 100%. The PWM clock frequency is programmed at Bank0 Index 4Ah, Index 4Bh, and Index 4Ch.

For DC, the NCT6102D / NCT6106D has a six bit digital-to-analog converter (DAC) that produces 0 to 2.048 Volts DC. The analog output is programmed at Bank1 Index 19h bit[7:2] for SYSFANOUT, Bank1 Index 29h bit[7:2] for CPUFANOUT and Bank1 Index 39h bit[7:2] for AUXFANOUT. The analog output can be calculated using the following equation:

$$\text{OUTPUT Voltage (V)} = V_{ref} \times \frac{\text{Programmed 6-bit Register Value}}{64}$$

The default value is 111111YY, or nearly 2.048 V, and Y is a reserved bit.

8.7.5 SMART FAN™ Control

The NCT6102D / NCT6106D supports various different fan control features:

- ◆ SMART FAN™ I (Thermal Cruise & Speed Cruise)
- ◆ SMART FAN™ IV
- ◆ Close-Loop Fan Control RPM mode

	SYSFANOUT	CPUFANOUT	AUXFANOUT
Fan Control Mode Select	Bank1, Index13, bit[7:4] 0h: Manual mode (def.)	Bank1, Index23, bit[7:4] 0h: Manual mode(def.)	Bank1, Index33, bit[7:4] 0h: Manual mode (def.)

	1h: Thermal Cruise 2h: Speed Cruise 4h: SMART FAN™ IV	1h: Thermal Cruise 2h: Speed Cruise 4h: SMART FAN™ IV	1h: Thermal Cruise 2h: Speed Cruise 4h: SMART FAN™ IV
--	---	---	---

8.7.6 Temperature Source & Reading for Fan Control

Select temperature source for each fan control output:

	SYSFANOUT	CPUFANOUT	AUXFANOUT
Fan Control Temperature Source Select	Bank1, Index10 bit[4:0] Default: SYSTIN	Bank1, Index20 bit[4:0] Default: CPUTIN	Bank1, Index30 bit[4:0] Default: AUXTIN
Fan Control Temperature Reading	Bank0, Index18 & Bank0, Index1B bit0	Bank0, Index19 & Bank0, Index1B bit1	Bank0, Index1A & Bank0, Index1B bit2
Close-Loop Fan Control RPM mode	Bank1, Index1E bit0	Bank1, Index2E bit0	Bank1, Index3E bit0

8.8 SMART FAN™ I

8.8.1 Thermal Cruise Mode

Thermal Cruise mode controls the fan speed to keep the temperature in a specified range. First, this range is defined in BIOS by a temperature and the interval (e.g., 55 °C ± 3 °C). As long as the current temperature remains below the low end of this range (i.e., 52 °C), the fan is off. Once the temperature exceeds the low end, the fan turns on at a speed defined in BIOS (e.g., 20% output). Thermal Cruise mode then controls the fan output according to the current temperature. Three conditions may occur:

- (1) If the temperature still exceeds the high end, fan output increases slowly. If the fan is operating at full speed but the temperature still exceeds the high end, a warning message is issued to protect the system.
- (2) If the temperature falls below the high end (e.g., 58°C) but remains above the low end (e.g., 52 °C), fan output remains the same.
- (3) If the temperature falls below the low end (e.g., 52 °C), fan output decreases slowly to zero or to a specified "stop value".

This "stop value enable" is enabled by the Bank1, Index10h, Bit7 for SYSFANOUT; Bank1, Index20h, Bit7 for CPUFANOUT and Bank1, Index30h, Bit7 for AUXFANOUT.

The "stop value" itself is separately specified in Bank1 Index16h, Bank1 Index26h and Bank1 Index36h.

The "stop time" means fan remains at the stop value for the period of time also separately defined in Bank1 Index18h, Bank1 Index28h and Bank1 Index38h.

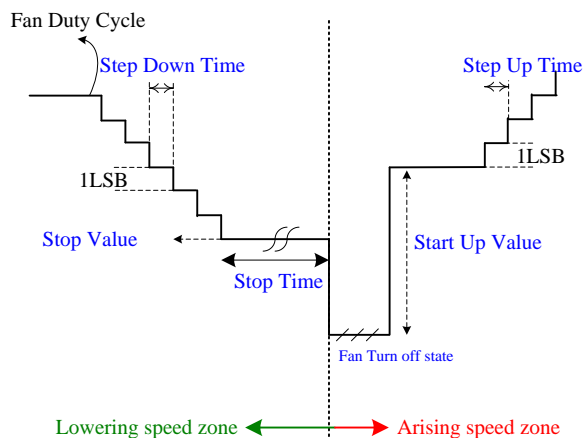

Figure 8-10 Thermal Cruise™ Mode Parameters Figure

In general, Thermal Cruise mode means

- If the current temperature is higher than the high end, increase the fan speed.
- If the current temperature is lower than the low end, decrease the fan speed.
- Otherwise, keep the fan speed the same.

The following figures illustrate two examples of Thermal Cruise mode.

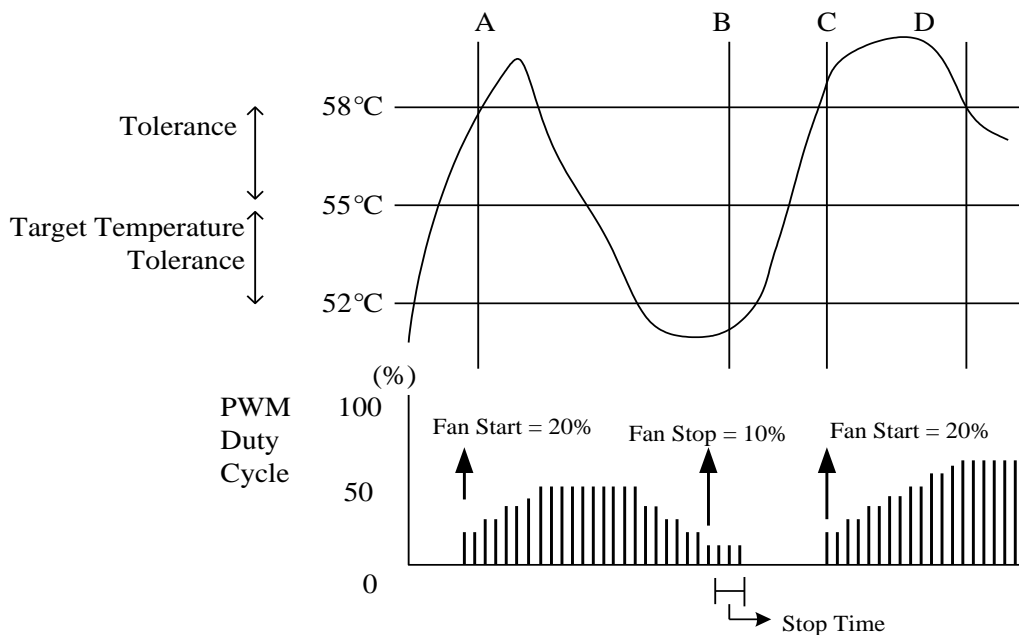

Figure 8-11 Mechanism of Thermal Cruise™ Mode (PWN Duty Cycle)

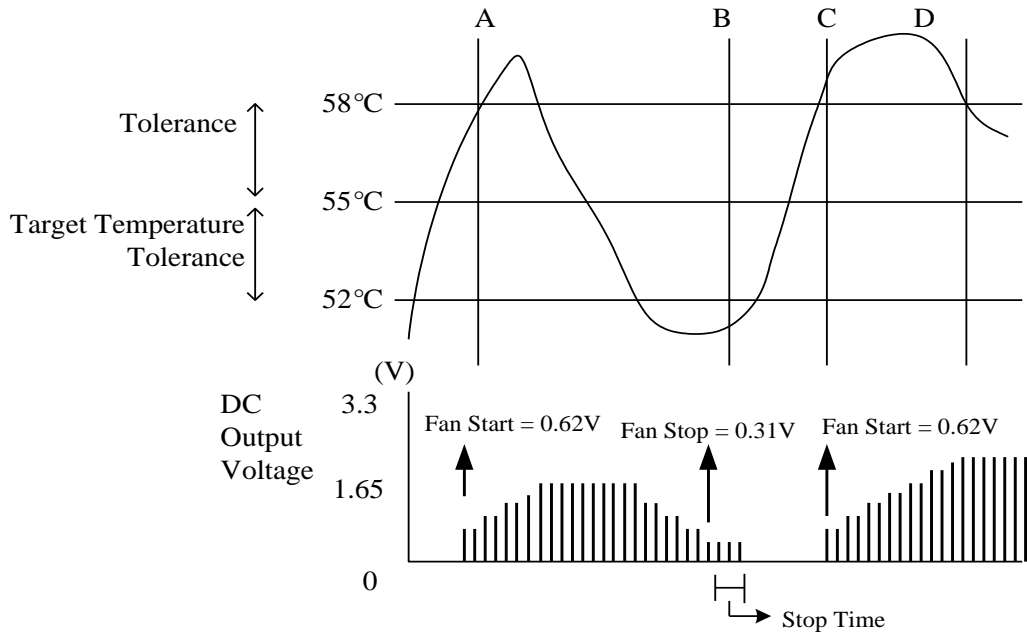

Figure 8-12 Mechanism of Thermal Cruise™ Mode (DC Output Voltage)

8.8.2 Speed Cruise Mode

Speed Cruise mode keeps the fan speed in a specified range. First, this range is defined in BIOS by a fan speed count (the amount of time between clock input signals, not the number of clock input signals in a period of time) and an interval (e.g., 160 ± 10). As long as the fan speed count is in the specified range, fan output remains the same. If the fan speed count is higher than the high end (e.g., 170), fan output increases to make the count lower. If the fan speed count is lower than the low end (e.g., 150), fan output decreases to make the count higher. One example is illustrated in this figure.

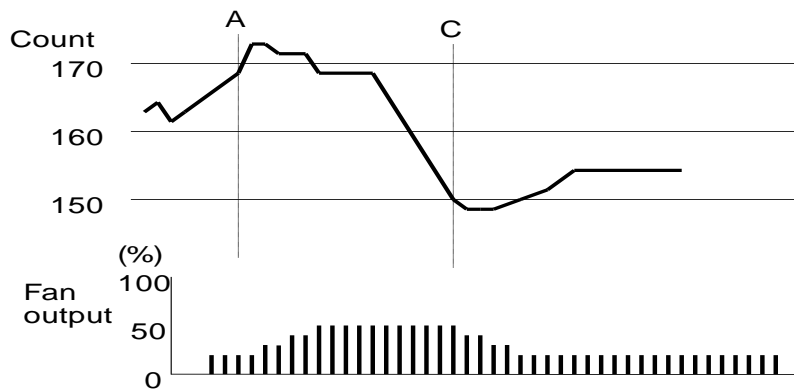

Figure 8-13 Mechanism of Fan Speed Cruise™ Mode

The following tables show current temperatures, fan output values and the relative control registers at Thermal Cruise and Fan Speed mode.

Table 8-2 Display Registers – at SMART FAN™ I Mode

DESCRIPTION	REGISTER ADDRESS	REGISTER NAME	ATTRIBUTE	BIT DATA
Current SYSFANOUT Temperature	Bank0, Index18h, Index1Bh bit0	SYSFAN MUX Temperature Sensor (default: SYSTIN)	Read only	Index 18h, unit 1°C Index 1Bh, bit 0, unit 0.5 °C
Current CPUFANOUT Temperature	Bank0, Index19h, Index1Bh bit1	CPUFAN MUX Temperature Sensor (default: CPUTIN)	Read only	Index 19h, unit 1°C Index 1Bh, bit 1, unit 0.5 °C
Current AUXFANOUT Temperature	Bank0, Index1Ah, Index1Bh bit2	AUXFAN MUX Temperature Sensor (default: AUX TIN)	Read only	Index 1Ah, unit 1°C Index 1Bh, bit 2, unit 0.5 °C
Current SYSFANOUT Output Value	Bank0, Index 4Ah	SYSFANOUT Output Value Select	Read only	
Current CPUFANOUT Output Value	Bank0, Index 4Bh	CPUFANOUT Output Value Select	Read only	
Current AUXFANOUT Output Value	Bank0, Index 4Ch	AUXFANOUT Output Value Select	Read only	

Table 8-3 Relative Registers – at Thermal Cruise™ Mode

THERMAL CRUISE MODE	CRITICAL TEMPERATURE	STEP- UP TIME	STEP- DOWN TIME	ENABLE THERMAL CRUISE MODE	ENABLE CRITICAL DUTY	CRITICAL DUTY
SYSFANOUT	Bank 1, Index 1Ah	Bank 1, Index 14h	Bank 1, Index 15h	Bank 1, Index 13h, bit[7:4] = 01h	Bank 1, Index 1Ch, bit4	Bank 1, Index 1Dh
CPUFANOUT	Bank 1, Index 2Ah	Bank 1, Index 24h	Bank 1, Index 25h	Bank 1, Index 23h, bit[7:4] = 01h	Bank 1, Index 2Ch, bit4	Bank 1, Index 2Dh
AUXFANOUT	Bank 1, Index 3Ah	Bank 1, Index 34h	Bank 1, Index 35h	Bank 1, Index 33h, bit[7:4] = 01h	Bank 1, Index 3Ch, bit4	Bank 1, Index 3Dh

THERMAL CRUISE MODE	TARGET TEMPERATURE	TOLERANCE	KEEP MIN. FAN OUTPUT VALUE	STOP VALUE	START-UP VALUE	STOP TIME
SYSFANOUT	Bank 1, Index 11h	Bank 1, Index 13h, Bit[2:0]	Bank 1, Index 10h, bit7	Bank 1, index 16h	Bank 1, index 17h	Bank 1, index 18h
CPUFANOUT	Bank 1, Index 21h	Bank 1, Index 23h, Bit[2:0]	Bank 1, Index 20h, bit7	Bank 1, index 26h	Bank 1, index 27h	Bank 1, index 28h
AUXFANOUT	Bank 1, Index 31h	Bank 1, Index 33h, Bit[2:0]	Bank 1, Index 30h, bit7	Bank 1, index 36h	Bank 1, index 37h	Bank 1, index 38h

Table 8-4 Relative Registers – at Speed Cruise™ Mode

SPEED CRUISE MODE	CRITICAL TEMPERATURE	STEP- UP TIME	STEP- DOWN TIME	ENABLE THERMAL CRUISE MODE	ENABLE CRITICAL DUTY	CRITICAL DUTY
SYSFANOUT	Bank 1, Index 1Ah	Bank 1, Index 14h	Bank 1, Index 15h	Bank 1, Index 13h, bit[7:4] = 02h	Bank 1, Index 1Ch, bit4	Bank 1, Index 1Dh
CPUFANOUT	Bank 1, Index 2Ah	Bank 1, Index 24h	Bank 1, Index 25h	Bank 1, Index 23h, bit[7:4] = 02h	Bank 1, Index 2Ch, bit4	Bank 1, Index 2Dh
AUXFANOUT	Bank 1, Index 3Ah	Bank 1, Index 34h	Bank 1, Index 35h	Bank 1, Index 33h, bit[7:4] = 02h	Bank 1, Index 3Ch, bit4	Bank 1, Index 3Dh

SPEED CRUISE MODE	TARGET-SPEED COUNT_L	TARGET-SPEED COUNT_H	TOLERANCE_L	TOLERANCE_H
SYSFANOUT	Bank 1, Index 11h	Bank 1, Index 12, bit[3:0]	Bank 1, Index 13h, Bit[2:0]	Bank 1, Index 12, bit[6:4]
CPUFANOUT	Bank 1, Index 21h	Bank 1, Index 22, bit[3:0]	Bank 1, Index 23h, Bit[2:0]	Bank 1, Index 22, bit[6:4]
AUXFANOUT	Bank 1, Index 31h	Bank 1, Index 32, bit[3:0]	Bank 1, Index 33h, Bit[2:0]	Bank 1, Index 32, bit[6:4]

8.9 SMART FAN™ IV & Close Loop Fan Control RPM Mode

SMART FAN™ IV and Close Loop Fan Control RPM Mode offer 3 slopes to control the fan speed.

Set **Critical Temperature**, Bank1 Address 1A_{HEX}, **Bank1 Address 2A_{HEX}**, **Bank1 Address 3A_{HEX}**

- Set the **Relative Register-at SMART FAN™ IV Control Mode Table**
 If fan control mode is set as Close Loop Fan Control, the unit step is 50 RPM. So the maximum controllable RPM is 50*255=12,750 rpm.
 If for High Speed Fan Control at RPM Mode, Set **RPM_High** of Bank1 Address 1F_{HEX} bit[7]. Address 2F_{HEX} bit[7]. Address 3F_{HEX} bit[7].
 the unit is 100 RPM, Support 100 rpm ~ 25500 rpm.
- Set **Hysteresis of Temperature, Bank1 Address 13_{HEX} bit[2:0]**. Bank1 Address 23_{HEX} bit[2:0]. Bank1 Address 33_{HEX} bit[2:0].

The 3 slopes can be obtained by setting FanDuty1/RPM1~FanDuty4/RPM4 and T1~T4 through the registers. When the temperature rises, FAN Output will calculate the target FanDuty/RPM based on the current slope. For example, assuming Tx is the current temperature and Ty is the target, then

The slope:

$$X2 = \frac{(FanDuty3 / RPM3) - (FanDuty2 / RPM2)}{(T3 - T2)}$$

Fan Output:

$$Target\ FanDuty\ or\ RPM = (FanDuty2\ or\ RPM2) + (Tx - T2) \cdot X2$$

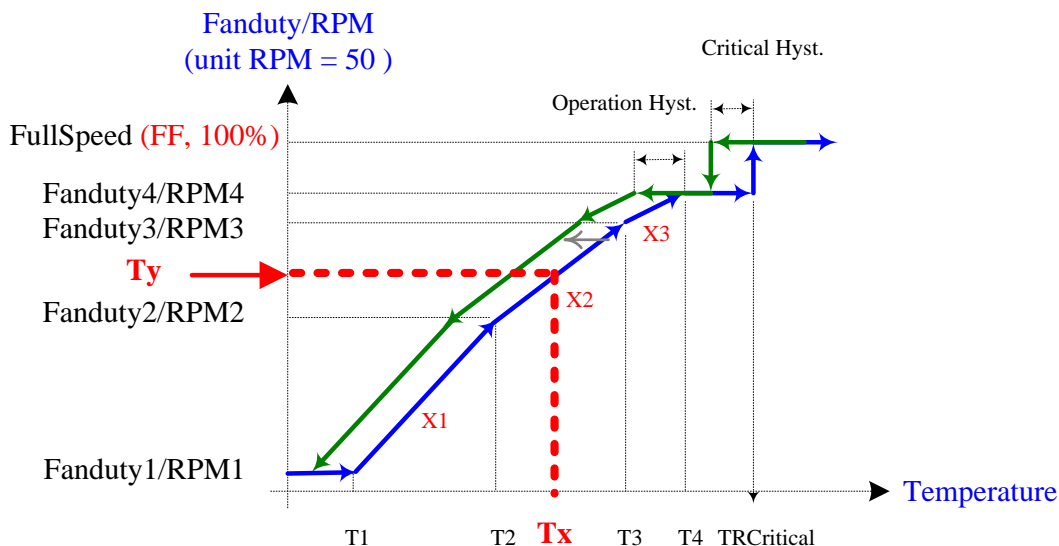

Figure 8-14 SMART FAN™ IV & Close Loop Fan Control Mechanism

Table 8-5 Relative Register-at SMART FAN™ IV Control Mode

DESCRIPTION	T1	T2	T3	T4
SYSFANOUT	Bank 1, Index 60h	Bank 1, Index 61h	Bank 1, Index 62h	Bank 1, Index 63h
CPUFANOUT	Bank 1, Index 70h	Bank 1, Index 71h	Bank 1, Index 72h	Bank 1, Index 73h
AUXFANOUT	Bank 1, Index 80h	Bank 1, Index 81h	Bank 1, Index 82h	Bank 1, Index 83h

DESCRIPTION	FD1/RPM1	FD2/RPM2	FD3/RPM3	FD4/RPM4
SYSFANOUT	Bank 1,	Bank 1,	Bank 1,	Bank 1,

	Index 64h	Index 65h	Index 66h	Index 67h
CPUFANOUT	Bank 1, Index 74h	Bank 1, Index 75h	Bank 1, Index 76h	Bank 1, Index 77h
AUXFANOUT	Bank 1, Index 84h	Bank 1, Index 85h	Bank 1, Index 86h	Bank 1, Index 87h

DESCRIPTION	STEP- UP TIME	STEP- DOWN TIME	ENABLE SMART IV MODE	ENABLE FANOUT STEP	ENABLE CRITICAL DUTY	CRITICAL DUTY
SYSFANOUT	Bank 1, Index 14h	Bank 1, Index 15h	Bank 1, Index 13h,bit[7:4] = 04h	Bank 1, Index 1Ch, bit0	Bank 1, Index 1Ch, bit4	Bank 1, Index 1Dh
CPUFANOUT	Bank 1, Index 24h	Bank 1, Index 25h	Bank 1, Index 23h,bit[7:4] = 04h	Bank 1, Index 2Ch, bit0	Bank 1, Index 2Ch, bit4	Bank 1, Index 2Dh
AUXFANOUT	Bank 1, Index 34h	Bank 1, Index 35h	Bank 1, Index 33h,bit[7:4] = 04h	Bank 1, Index 3Ch, bit0	Bank 1, Index 3Ch, bit4	Bank 1, Index 3Dh

DESCRIPTION	CRITICAL TEMPERATURE	CRITICAL TOLERANCE	TEMPERATURE TOLERANCE	ENABLE RPM MODE	RPM TOLERANCE	ENABLE RPM HIGH MODE
SYSFANOUT	Bank 1, Index 1Ah	Bank 1, Index 1Bh, bit[2:0]	Bank1, Index 13h, bit[2:0]	Bank 1, Index 1Eh, bit0	Bank1, Index 1Fh, bit[3:0]	Bank 1, Index 1Fh, bit7
CPUFANOUT	Bank 1, Index 2Ah	Bank 1, Index 2Bh, bit[2:0]	Bank1, Index 23h, bit[2:0]	Bank 1, Index 2Eh, bit0	Bank1, Index 2Fh, bit[3:0]	Bank 1, Index 2Fh, bit7
AUXFANOUT	Bank 1, Index 3Ah	Bank 1, Index 3Bh, bit[2:0]	Bank1, Index 33h, bit[2:0]	Bank 1, Index 3Eh, bit0	Bank1, Index 3Fh, bit[3:0]	Bank 1, Index 3Fh, bit7

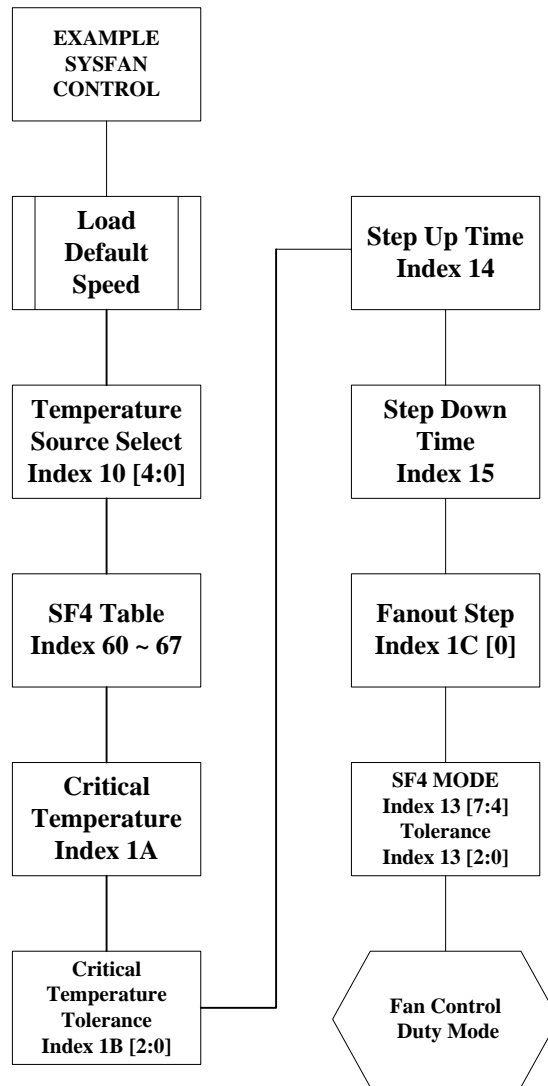

Figure 8-15 Fan Control Duty Mode Programming Flow

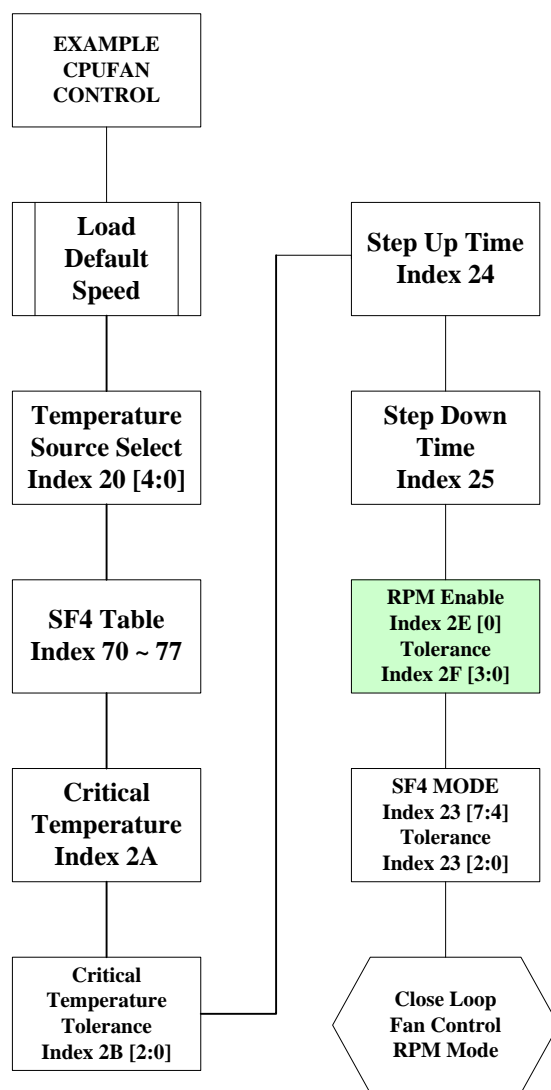

Figure 8-16 Close-Loop Fan Control RPM Mode Programming Flow

8.9.1 Step Up Time / Step Down Time

SMART FAN™ IV is designed for the smooth operation of the fan. The Up Time / Down Time register defines the time interval between successive duty increases or decreases. If this value is set too small, the fan will not have enough time to speed up after tuning the duty and sometimes may result in unstable fan speed. On the otherhand, if Up Time / Down Time is set too large, the fan may not work fast enough to dissipate the heat. This register should never be set to 0, otherwise, the fan duty will be abnormal.

8.9.2 Fan Output Step

The “Fanout Step” itself is separately specified in Bank1 Index1Ch bit0 for SYSFANOUT, Index2Ch bit0 for CPUFANOUT and Index3Ch bit0 for AUXFANOUT.

This example for Fanout Step exposition:

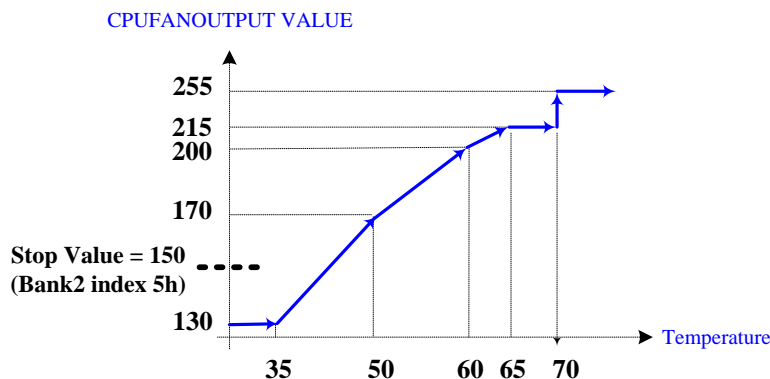

Figure 8-17 CPUFAN SMART FAN™ IV Table Parameters Figure

FANOUT STEP (Bank2 Index 20h bit0)	[Step up]														
Temperature	50	55	60	61			62	50	35	44					
CPUFANOUTPUT VALUE (Bank0 Index 3h)	170	185	200	201	202	203	204	205	206	...	170	150	151	152	153
Target Duty	170	185	200	203			206			170	130		153		
Step Up/Down Time (Bank2 Index 3,4h)	T = 1 sec			T = 0.5 sec											

Figure 8-18 Fanout Step Relation of CPUFANOUT

8.9.3 Revolution Pulse Selection

The NCT6102D / NCT6106D supports four RPM output of the pulses selection function for different type of FAN which has the character of different pulses per revolution. The others could be set by HM register at Bank0, IndexF6, Bit1-0 for SYSFANIN; Bank0, IndexF6, Bit3-2 for CPUFANIN and Bank0, IndexF6, Bit5-4 for AUXFANIN. All default value of pulse selection registers are 2 pulses of one revolution.

Setting description for “Pulse Selections Bits”:

- 00:** 4 pulses per revolution
- 01:** 1 pulse per revolution
- 10:** 2 pulses per revolution (default)
- 11:** 3 pulses per revolution

8.9.4 Weight Value Control

The NCT6102D / NCT6106D supports weight value control for fan duty output. By register configuration, the results of weight value circuit can be added to the fan duty of Thermal Cruise Mode or SMART FAN™ IV Duty Mode and output to the fan. Take CPUFANOUT for example, if SMART FAN™ IV is selected, CPUTIN is the temperature source, and weight value control is enabled, SMART FAN™ IV will calculate the output duty, and weight value circuit will calculate the corresponding weight value based on SYSTIN. As the SYSTIN temperature rises, its corresponding weight value increases. Then, the two values will be summed up and output to CPU fan. In other words, the CPU fan duty is affected not only by the CPUTIN but also the SYSTIN temperature.

Figure 8-19 SYS TEMP and Weight Value Relations shows the relation between the SYSTIN temperature and the weight value. Tolerance setup is offered on each change point to avoid weight value fluctuation resulted from SYSTIN temperature change. The weight value will increase by one weight value step only when the SYSTIN temperature is higher than the point value plus tolerance. Likewise, the weight value decreases by one weight value step only when the SYSTIN temperature is lower than the point value minus tolerance.

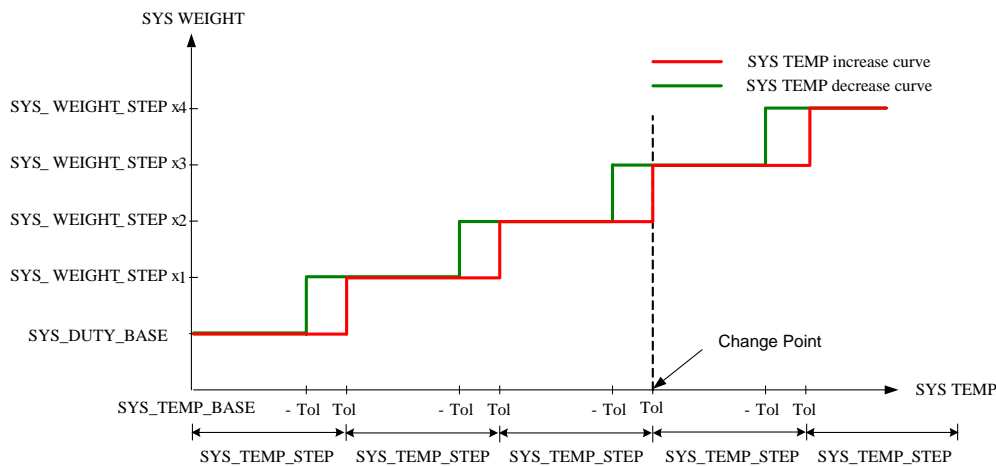

Figure 8-19 SYS TEMP and Weight Value Relations

Table 8-6 Relative Register-at Weight Value Control

DESCRIPTION	ENABLE WEIGHT MODE	WEIGHT TEMPERATURE SOURCE SELECT
SYSFANOUT	Bank 1, Index 68h, bit7	Bank 1, Index 68h, bit[4:0]
CPUFANOUT	Bank 1, Index 78h, bit7	Bank 1, Index 78h, bit[4:0]
AUXFANOUT	Bank 1, Index 88h, bit7	Bank 1, Index 88h, bit[4:0]

DESCRIPTION	TEMP STEP	TEMP STEP TOLERANCE	WEIGHT STEP	TEMP BASE	DUTY BASE
SYSFANOUT	Bank 1, Index 69h	Bank 1, Index 6Ah	Bank 1, Index 6Bh	Bank 1, Index 6Ch	Bank 1, Index 6Dh
CPUFANOUT	Bank 1, Index 79h	Bank 1, Index 7Ah	Bank 1, Index 7Bh	Bank 1, Index 7Ch	Bank 1, Index 7Dh
AUXFANOUT	Bank 1, Index 89h	Bank 1, Index 8Ah	Bank 1, Index 8Bh	Bank 1, Index 8Ch	Bank 1, Index 8Dh

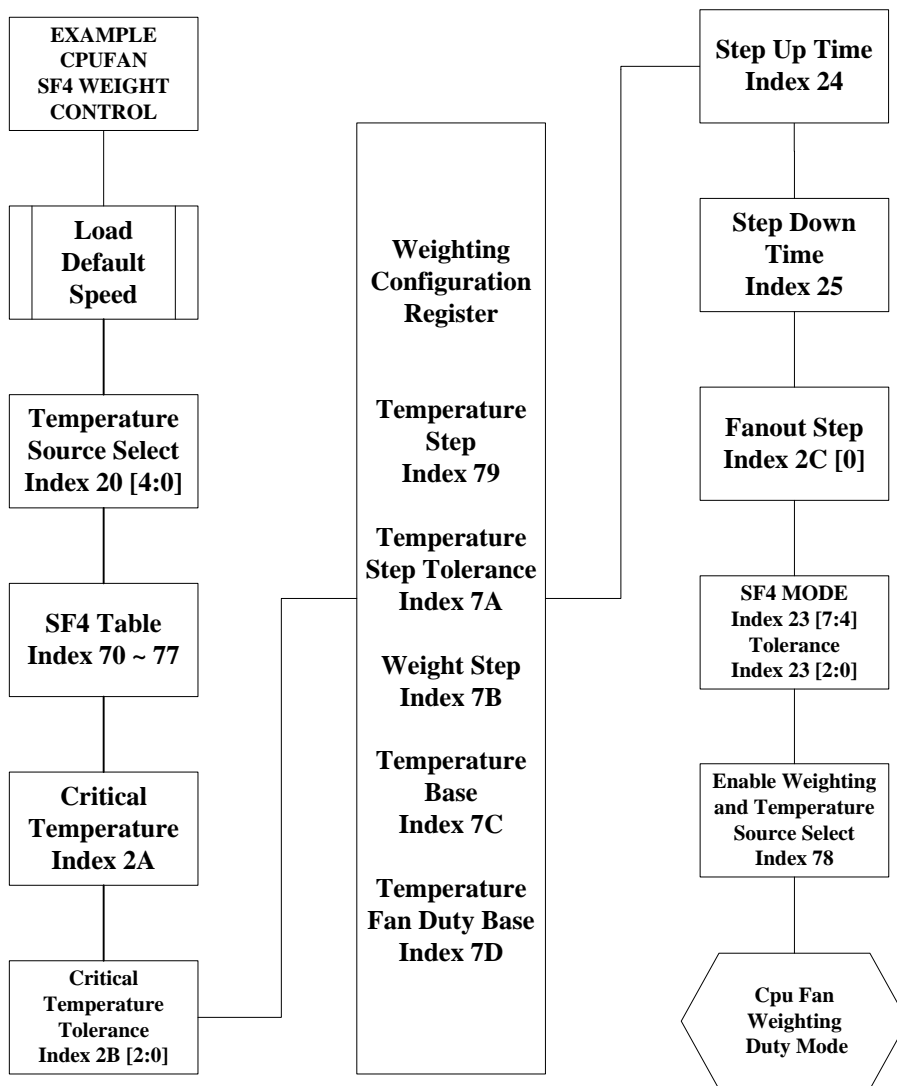

Figure 8-20 Weighting Duty Mode Programming Flow

8.10 Alert and Interrupt

NCT6102D / NCT6106D supports 6 Temperature Sensors for interrupt detection depending on selective monitor temperature source.

	SMIIOVT1	SMIIOVT2	SMIIOVT3	SMIIOVT4	SMIIOVT5	SMIIOVT6
Temperature source select	Bank0, indexB0 bit[4:0] default: SYSTIN	Bank0, indexB1 bit[4:0] default: CPUTIN	Bank0, indexB2 bit[4:0] default: AUXTIN	Bank0, indexB3 bit[4:0] default: SYSTIN	Bank0, indexB4 bit[4:0] default: SYSTIN	Bank0, indexB5 bit[4:0] default: SYSTIN
Temperature reading (2's)	Bank0, index10 &	Bank0, index11 &	Bank0, index12 &	Bank0, index13 &	Bank0, index14 &	Bank0, index15 &

complement)	index16 bit0	index16 bit1	index16 bit2	index16 bit3	index16 bit4	index16 bit5
Temperature High Limit	Bank0, indexC2 & indexB7 bit6	Bank0, indexC6 & indexB8 bit6	Bank0, indexCA & indexB9 bit6	Bank0, indexCE & indexBA bit6	Bank0, indexD2 & indexBB bit6	Bank0, indexD6 & indexBC bit6
Temperature Low Limit	Bank0, indexB7 & index56 bit7	Bank1, indexC7 & indexB8 bit7	Bank2, indexCB & indexB9 bit7	Bank6, indexCF & indexBA bit0	Bank6, indexD3 & indexBB bit0	Bank6, indexD7 & indexBC bit0

SMIOVT Relative Temperature Registers

8.10.1 SMI# Interrupt Mode

The SMI#/OVT# pin (pin.95) is a multi-function pin. It can be in HM_SMI# mode or in OVT# mode by setting Configuration Register CR29h, bit 6 to one or zero, respectively. In HM_SMI# mode, it can monitor voltages, fan counts, or temperatures.

8.10.2 Voltage SMI# Mode

The SMI# pin can create an interrupt if a voltage exceeds a specified high limit or falls below a specified low limit. This interrupt must be reset by reading all the interrupt status registers, or subsequent events do not generate interrupts. This mode is illustrated in the following figure.

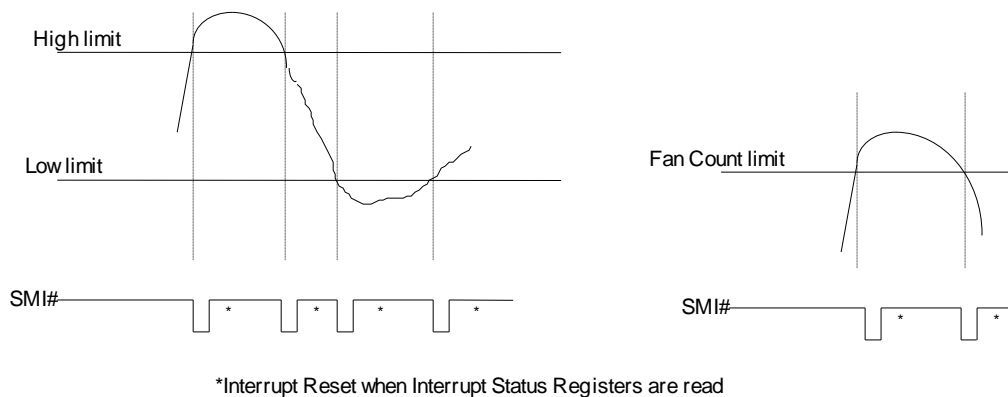

Figure 8-21 SMI Mode of Voltage and Fan Inputs

8.10.3 Fan SMI# Mode

The SMI# pin can create an interrupt if a fan count crosses a specified fan limit (rises above it or falls below it). This interrupt must be reset by reading all the interrupt status registers, or subsequent events do not generate interrupts. This mode is illustrated in the figure above.

8.10.4 Temperature SMI# Mode

The SMI# pin can create interrupts that depend on the temperatures measured by SYSTIN, CPUTIN, and AUXIN. These interrupts are divided into two parts, one for SYSTIN and the other for CPUTIN / AUXIN.

8.10.4.1. Temperature Sensor 1 SMI# Interrupt (Default: SYSTIN)

The SMI# pin has five interrupt modes with Temperature Sensor 1.

(1) Shut-down Interrupt Mode

This mode is enabled by setting T_{HYST} (Temperature Hysteresis) lower than T_{OL} and setting Bank0 Index 40h, bit 4 to one.

In this mode, the SMI# pin can create an interrupt when the current temperature rises above T_{OL} or Shut-down mode high limit temperature, and when the current temperature falls below T_{HYST} or Shut-down mode low limit temperature. Once the temperature rises above T_{OL} , however, and generates an interrupt, this mode does not generate additional interrupts, even if the temperature remains above T_{OL} , until the temperature falls below T_{HYST} . This interrupt must be reset by reading all the interrupt status registers, or subsequent events do not generate interrupts, except the first time current temperature rises above Shut-down mode high limit temperature. This is illustrated in the following figure.

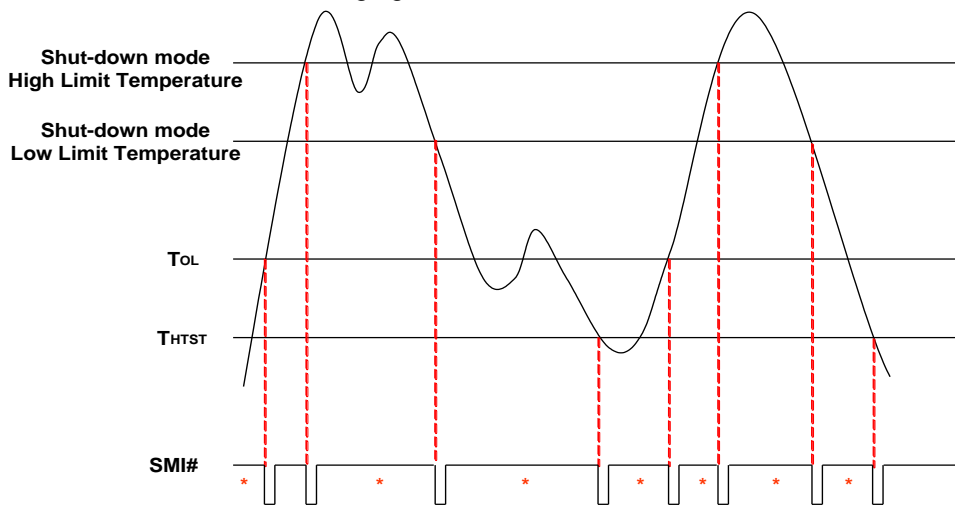

* Interrupt Reset when Interrupt Status Registers are read

Figure 8-22 Shut-down Interrupt Mode

(2) Comparator Interrupt Mode

This mode is enabled by setting T_{HYST} (Temperature Hysteresis) to 127°C.

In this mode, the SMI# pin can create an interrupt as long as the current temperature exceeds T_O (Over Temperature). This interrupt can be reset by reading all the interrupt status registers, or subsequent events do not generate interrupts. If the interrupt is reset, the SMI# pin continues to create interrupts until the temperature goes below T_O . This is illustrated in the figure below.

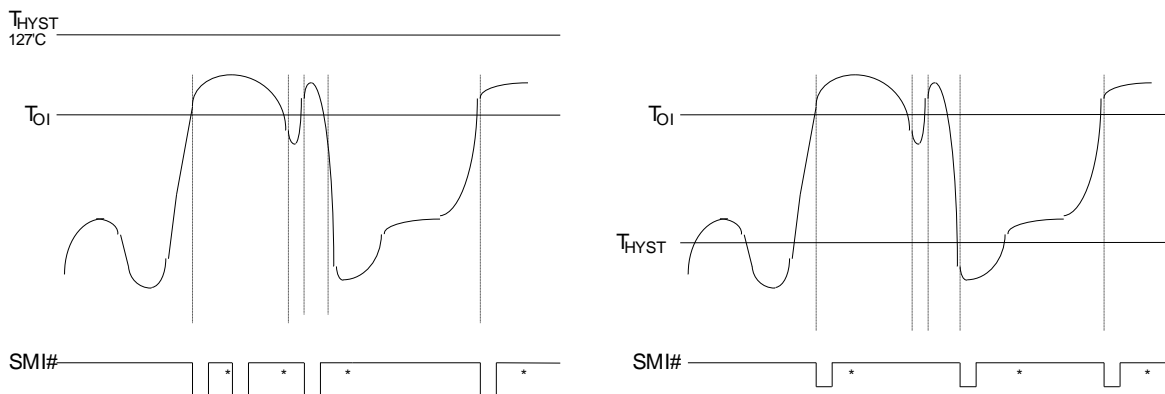

*Interrupt Reset when Interrupt Status Registers are read

In this mode, the SMI# pin can create an interrupt when the current temperature rises above T_{OL} or Shut-down mode high limit temperature, and when the current temperature falls below T_{HYST} or Shut-down mode low limit temperature. Once the temperature rises above T_{OL} , however, and generates an interrupt, this mode does not generate additional interrupts, even if the temperature remains above T_{OL} , until the temperature falls below T_{HYST} . This interrupt must be reset by reading all the interrupt status registers, or subsequent events do not generate interrupts, except the first time current temperature rises above Shut-down mode high limit temperature. This is illustrated in the following figure.

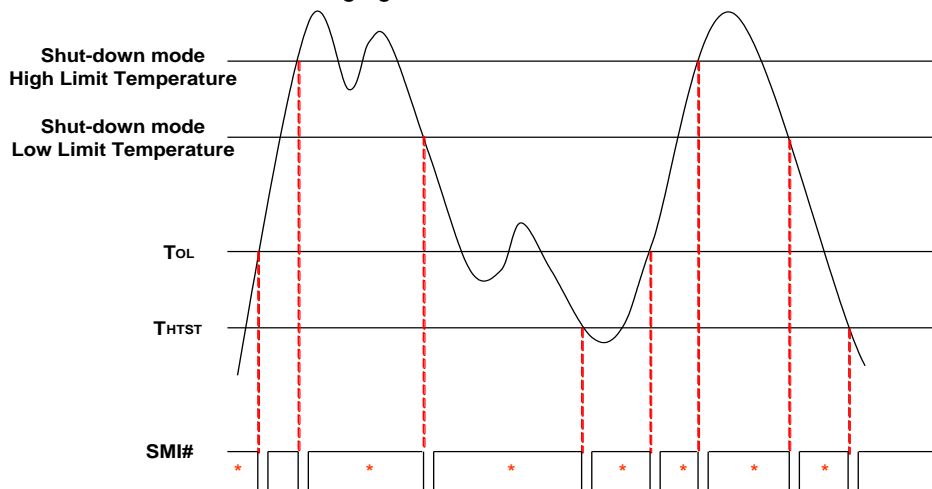

* Interrupt Reset when Interrupt Status Registers are read

Figure 8-25 Shut-down Interrupt Mode

(2) Comparator Interrupt Mode

This mode is enabled by setting Bank0 Index B6h, bit 2, to one.

In this mode, the SMI# pin can create an interrupt when the current temperature exceeds T_O (Over Temperature) and continues to create interrupts until the temperature falls below T_{HYST} . This interrupt can be reset by reading all the interrupt status registers, or subsequent events do not generate interrupts. This is illustrated in the figure below.

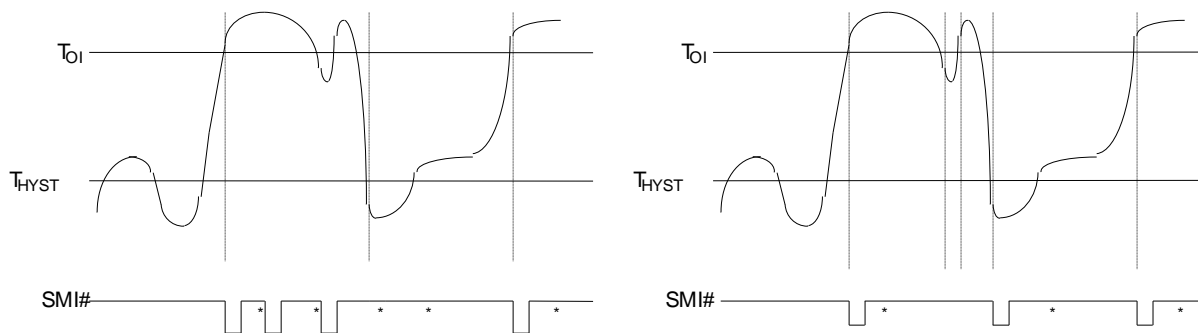

*Interrupt Reset when Interrupt Status Registers are read

Comparator Interrupt Mode

Two-Times Interrupt Mode

Figure 8-26 SMI Mode of CPUTIN

(3) Two-Times Interrupt Mode

This mode is enabled by setting Bank0 Index B6h, bit 2, to zero.

In this mode, the SMI# pin can create an interrupt when the current temperature rises above T_O or when the current temperature falls below T_{HYST} . Once the temperature rises above T_O , however, and generates an interrupt, this mode does not generate additional interrupts, even if the temperature remains above T_O , until the temperature falls below T_{HYST} . This interrupt must be reset by reading all the interrupt status registers, or subsequent events do not generate interrupts. This is illustrated in the figure above.

Table 8-7 Relative Register of SMI functions

	SHUTDOWN MODE	COMPARATOR MODE	TWO-TIME INTERRUPT MODE	ONE-TIME INTERRUPT MODE
SMIOVT1	Bank0,IndexB7_Bit2 (EN_WS=1) Bank0,Index82_Bit0(TIN=0) Bank0,Index83_Bit0 (Shut = 0)	Bank0,Index82_Bit0 (TIN=0) Bank0,IndexC3 (Thyst = 8'h7F)	Bank0,Index82_Bit0 (TIN=0) Bank0,IndexB6_Bit1 (EN_T1_One = 0)	Bank0,Index82_Bit0 (TIN=0) Bank0,IndexB6_Bit1 (EN_T1_One= 1)
SMIOVT2	Bank0,IndexB8_Bit2 (EN_WS=1) Bank0,Index82_Bit1(TIN=0) Bank0,Index83_Bit1 (Shut = 0)	Bank0,Index82_Bit1 (TIN=0) Bank0,IndexB6_Bit2 (T2T3_INT=1)	Bank0,Index82_Bit1 (TIN=0) Bank0,IndexB6_Bit2 (T2T3_INT=0)	
SMIOVT3	Bank0,IndexB9_Bit2 (EN_WS=1) Bank0,Index82_Bit2(TIN=0) Bank0,Index83_Bit2 (Shut = 0)	Bank0,Index82_Bit2 (TIN=0) Bank0,IndexB6_Bit2 (T2T3_INT=1)	Bank0,Index82_Bit1 (TIN=0) Bank0,IndexB6_Bit2 (T2T3_INT=0)	
SMIOVT4	Bank0,IndexBA_Bit2(EN_WS=1) Bank4,Index82_Bit3(TIN=0) Bank4,Index83_Bit3 (Shut = 0)	Bank4,Index82_Bit3 (TIN=0) Bank0,IndexB6_Bit2 (T2T3_INT=1)	Bank0,Index82_Bit1 (TIN=0) Bank0,IndexB6_Bit2 (T2T3_INT=0)	
SMIOVT5	Bank0,IndexBB_Bit2(EN_WS=1) Bank4,Index82_Bit4(TIN=0) Bank4,Index83_Bit4 (Shut = 0)	Bank4,Index82_Bit4 (TIN=0) Bank0,IndexB6_Bit2 (T2T3_INT=1)	Bank0,Index82_Bit1 (TIN=0) Bank0,IndexB6_Bit2 (T2T3_INT=0)	
SMIOVT6	Bank0,IndexBC_Bit2(EN_WS=1) Bank4,Index82_Bit5 (TIN=0)	Bank4,Index82_Bit5 (TIN=0) Bank0,IndexB6_Bit2 (T2T3_INT=1)	Bank0,Index82_Bit1 (TIN=0) Bank0,IndexB6_Bit2 (T2T3_INT=0)	



	Bank4, Index83_Bit5 (Shut = 0)		
--	-----------------------------------	--	--

Table 8-8 Relative Register of OVT functions

SMIOVT1	SMIOVT2	SMIOVT3
<p>Bank0, IndexB7_Bit0 0: Start to monitor the source of SMIOVT1 temperature. 1: Stop to monitor the source of SMIOVT1 temperature.</p> <p>Bank 0, IndexB7_Bit 1 0: Comparator Mode 1: Interrupt Mode</p> <p>Bank 0, InedexB7_Bit 3 0: Enable SMIOVT1 temperature sensor over temperature output 1: Disable SMIOVT1 temperature sensor over temperature output</p>	<p>Bank0, IndexB8_Bit0 0: Start to monitor the source of SMIOVT2 temperature. 1: Stop to monitor the source of SMIOVT2 temperature.</p> <p>Bank 0, IndexB8_Bit 1 0: Comparator Mode 1: Interrupt Mode</p> <p>Bank 0, InedexB8_Bit 3 0: Enable SMIOVT2 temperature sensor over temperature output 1: Disable SMIOVT2 temperature sensor over temperature output</p>	<p>Bank0, IndexB9_Bit0 0: Start to monitor the source of SMIOVT3 temperature. 1: Stop to monitor the source of SMIOVT3 temperature.</p> <p>Bank 0, IndexB9_Bit 1 0: Comparator Mode 1: Interrupt Mode</p> <p>Bank 0, InedexB9_Bit 3 0: Enable SMIOVT3 temperature sensor over temperature output 1: Disable SMIOVT3 temperature sensor over temperature output</p>
SMIOVT4	SMIOVT5	SMIOVT6
<p>Bank0, IndexBA_Bit0 0: Start to monitor the source of SMIOVT4 temperature. 1: Stop to monitor the source of SMIOVT4 temperature.</p> <p>Bank 0, IndexBA_Bit 1 0: Comparator Mode 1: Interrupt Mode</p> <p>Bank 0, InedexBA_Bit 3 0: Enable SMIOVT4 temperature sensor over temperature output 1: Disable SMIOVT4 temperature sensor over temperature output</p>	<p>Bank0, IndexBB_Bit0 0: Start to monitor the source of SMIOVT5 temperature. 1: Stop to monitor the source of SMIOVT5 temperature.</p> <p>Bank 0, IndexBB_Bit 1 0: Comparator Mode 1: Interrupt Mode</p> <p>Bank 0, InedexBB_Bit 3 0: Enable SMIOVT5 temperature sensor over temperature output 1: Disable SMIOVT5 temperature sensor over temperature output</p>	<p>Bank0, IndexBC_Bit0 0: Start to monitor the source of SMIOVT6 temperature. 1: Stop to monitor the source of SMIOVT6 temperature.</p> <p>Bank 0, IndexBC_Bit 1 0: Comparator Mode 1: Interrupt Mode</p> <p>Bank 0, InedexBC_Bit 3 0: Enable SMIOVT6 temperature sensor over temperature output 1: Disable SMIOVT6 temperature sensor over temperature output</p>

8.10.5 OVT# Interrupt Mode

The SMI#/OVT# pin is a multi-function pin. It can be in SMI# mode or in OVT# mode by setting Configuration Register CR[29h], bit 6 to one or zero, respectively. In OVT# mode, it can monitor temperatures, and OVT pin could be enabled to OVT output by Bank0 Index B7h, bit 3 for Temperature Sensor 1(default: SYSTIN); Bank0 Index B8h, bit 3 for Temperature Sensor 2(default: CPUTIN); Bank0 Index B9h, bit3 for Temperature Sensor 3(default: AUX TIN); Bank0 Index BAh, bit3 for Temperature Sensor 4(default: SYSTIN); Bank0 Index BBh, bit3 for Temperature Sensor 5(default: SYSTIN)and Bank0 Index BCh, bit3 for Temperature Sensor 6(default: SYSTIN).

The OVT# pin has two interrupt modes, comparator and interrupt. The modes are illustrated in this figure.

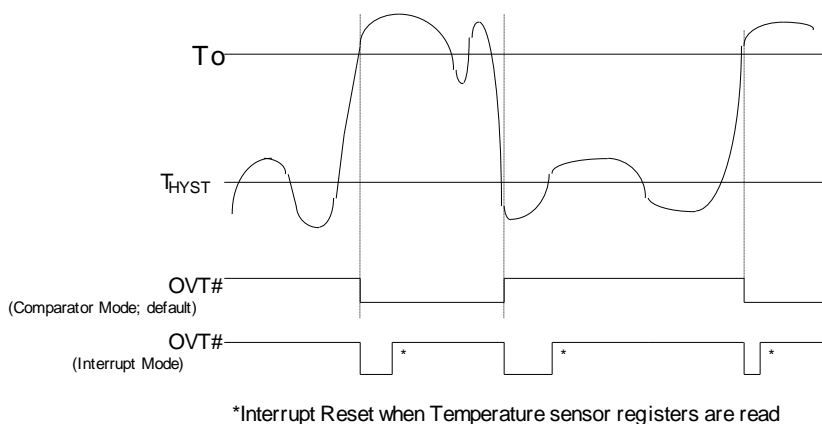

Figure 8-27 OVT# Modes of Temperature Inputs

If Bank0 Index B7h, bit 1, is set to zero, the OVT# pin is in comparator mode. In comparator mode, the OVT# pin can create an interrupt once the current temperature exceeds T_O and continues to create interrupts until the temperature falls below T_{HYST} . The OVT# pin is asserted once the temperature has exceeded T_O and has not yet fallen below T_{HYST} .

If Bank0 Index B7h, bit 1, is set to one, the OVT# pin is in interrupt mode. In interrupt mode, the OVT# pin can create an interrupt once the current temperature rises above T_O or when the temperature falls below T_{HYST} . Once the temperature rises above T_O , however, and generates an interrupt, this mode does not generate additional interrupts, even if the temperature remains above T_O , until the temperature falls below T_{HYST} . This interrupt must be reset by reading all the interrupt status registers. The OVT# pin is asserted when an interrupt is generated and remains asserted until the interrupt is reset.

8.10.6 Caseopen Detection

The purpose of Caseopen function is used to detect whether the computer case has been opened and possible tampered with. This feature must function even when there is no 3VSB power. Consequently, the power source for the circuit is from either Pin 74 (VBAT) or Pin 61 (3VSB). 3VSB is the default power source. If there is no 3VSB power, the power source is VBAT. This is designed to save power consumption of the battery.

When the case is closed, CASEOPEN# (pin 76) must be pulled high by an externally pulled-up $2M\Omega$ resistor that is connected to VBAT (pin 74). When the case is opened, CASEOPEN# will be switched from high to low. Meanwhile, the detection circuit inside the IC latches the signal. As a result, the interrupt status and the real-time status can be

read at the registers next time when the computer is powered. The CASEOPEN# status will not be cleared unless CR[46h], bit 7, or CR[E6h] bit 5 at Logical Device A is set to "1" first and then to "0".

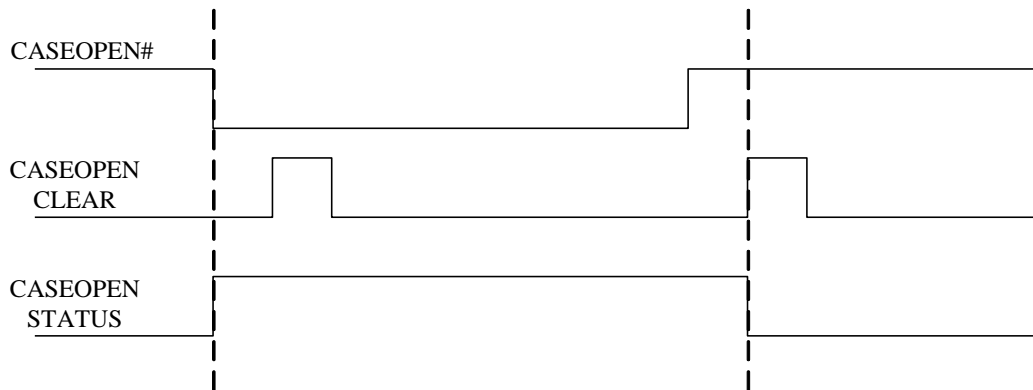

Figure 8-28 Caseopen Mechanism

8.11 Power Measurement

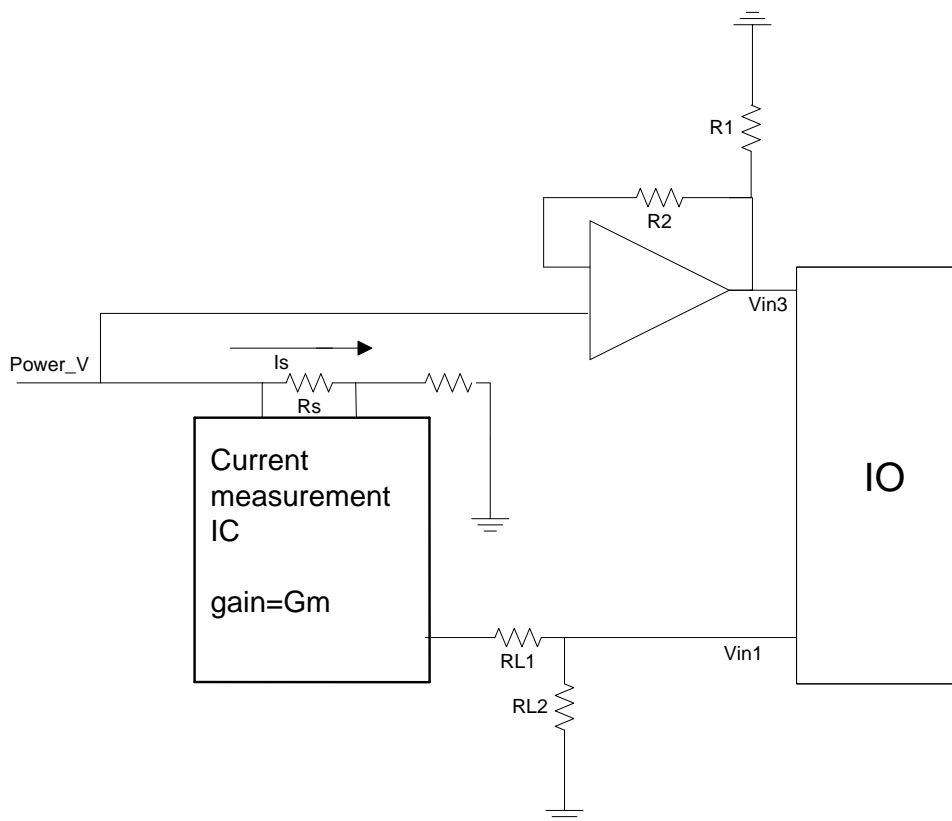

Figure 8-29 Power measurement architecture

This function will detect the voltage from current measurement IC on board and calculate the current and power. Fig 8.29 is the architecture. $V_{in3} = Power_V \times \frac{R1}{R1 + R2}$ and $V_{in1} = I_s \times R_s \times G_m \times RL2$ could not over 2.048. We suggest the ratio $\frac{R1}{R1 + R2} = \frac{1}{15}$.

	HM Register	Note
Is	Bank3 Index D0h & Index D1h	Calculate by IO
POWER	Bank3 Index D2h & Index D3h	Calculate by IO
VIN	Bank3 Index D4h	Given by user
Rre	Bank3 Index D5h	Given by user $R_{reg} = R_s * RL2 * G_m$
Reg_Ration_K	Bank3 Index D6h	Given by user $Reg_Ration_K = (R1 + R2) / (R1)$
Power_Volt_En	Bank3 Index D6h	Given by user
POWER_V	Bank3 Index D7h	Calculate by IO or given by user depend on Power_Volt_En
Vin1	Bank0 Index 04h	Measure by IO



9. HARDWARE MONITOR REGISTER SET

The base address of the Address Port and Data Port is specified in registers CR[60h] and CR[61h] of Logical Device B, the hardware monitor device. CR[60h] is the high byte, and CR[61h] is the low byte. The Address Port and Data Port are located at the base address, plus 5h and 6h, respectively. For example, if CR[60h] is 02h and CR[61h] is 90h, the Address Port is at 0x295h, and the Data Port is at 0x296h.

Remember that this access is from the host CPU I/O address range. To conserve space in the crowded CPU I/O addresses, many of the hardware monitor registers are “banked” with the bank number located at index 04Eh. Indexes from 000h to 04Fh are “global” or accessible from all banks, while indexes 050h to 0FFh are specific to each bank.

9.1 Address Port (Port x5h)

Attribute: Bit 6:0 Read/Write , Bit 7: Reserved

Size: 8 bits

BIT	7	6	5	4	3	2	1	0
NAME	DATA							
DEFAULT	0	0	0	0	0	0	0	0

BIT	DESCRIPTION
7	RESERVED.
6-0	READ/WRITE.

BIT 7	BIT 6	BIT 5	BIT 4	BIT 3	BIT 2	BIT 1	BIT 0
Reserved (Power On default 0)	Address Pointer (Power On default 00h)						
	A6	A5	A4	A3	A2	A1	A0

9.2 Data Port (Port x6h)

Attribute: Read/Write

Size: 8 bits

BIT	7	6	5	4	3	2	1	0
NAME	DATA							
DEFAULT	0	0	0	0	0	0	0	0

BIT	DESCRIPTION
7-0	Data to be read from or to be written to Value RAM and Register.

9.3 Value RAM — Index 00h ~ 6Fh (Bank 0)

ADDRESS 00-6F	DESCRIPTION
00h	CPUVCORE reading
01h	VIN0 reading
02h	AVSB reading
03h	3VCC reading
04h	VIN1 reading
05h	VIN2 reading
06h	RESERVED
07h	3VSB reading.
08h	VBAT reading
09h	V10 reading
0Ah	RESERVED
0Bh	RESERVED
0Ch	RESERVED
0Dh	RESERVED
0Eh	RESERVED
0Fh	RESERVED
10h	SMIOVT1 temperature reading
11h	SMIOVT2 temperature reading
12h	SMIOVT3 temperature reading
13h	SMIOVT4 temperature reading
14h	SMIOVT5 temperature reading
15h	SMIOVT6 temperature reading
16h	SMIOVT1~6 temperature reading LSB
17h	RESERVED
18h	System fan control temperature reading
19h	CPU fan control temperature reading
1Ah	AUX fan control temperature reading
1Bh	Fan control temperature reading LSB
1Ch	System fan weighting temperature reading
1Dh	CPU fan weighting temperature reading
1Eh	AUX fan weighting temperature reading
1Fh	fan weighting temperature reading LSB
20h	SYS fan count reading [12:5]
21h	SYS fan count reading [4:0]

ADDRESS 00-6F	DESCRIPTION
22h	CPU fan count reading [12:5]
23h	CPU fan count reading [4:0]
24h	AUX fan count reading [12:5]
25h	AUX fan count reading [4:0]
26h	RESERVED
27h	RESERVED
28h	RESERVED
29h	RESERVED
2Ah	SYS fan target
2Bh	CPU fan target
2Ch	AUX fan target
2Dh	RESERVED
2Eh	RESERVED
2Fh	RESERVED
30h	System fan RPM value reading high byte
31h	System fan RPM value reading low byte
32h	CPU fan RPM value reading high byte
33h	CPU fan RPM value reading low byte
34h	AUX fan RPM value reading high byte
35h	AUX fan RPM value reading low byte
36h	RESERVED
37h	RESERVED
38h	RESERVED
39h	RESERVED
3Ah	System FANIN RPM target (unit is 50 RPM)
3Bh	CPU FANIN RPM target (unit is 50 RPM)
3Ch	AUX FANIN RPM target (unit is 50 RPM)
3Dh	RESERVED
3Eh	RESERVED
3Fh	RESERVED
40h	RESERVED
41h	RESERVED
42h	RESERVED
43h	RESERVED
44h	RESERVED
45h	RESERVED

ADDRESS 00-6F	DESCRIPTION
46h	RESERVED
47h	RESERVED
48h	RESERVED
49h	RESERVED
4Ah	System fan duty
4Bh	CPU fan duty
4Ch	AUX fan duty
4Dh	RESERVED
4Eh	Bank select register
4Fh	Port 80 data input
50h	PCH_CHIP_CPU_MAX_Temperature
51h	PCH_CHIP_Temperature
52h	PCH_CPU_TEMP_H
53h	PCH_CPU_TEMP_L
54h	PCH_MCH_TEMP
55h	PCH_DIM0_TEMP
56h	PCH_DIM1_TEMP
57h	PCH_DIM2_TEMP
58h	PCH_DIM3_TEMP
59h	TSI Agent 0 temperature high byte
5Ah	TSI Agent 0 temperature low byte
5Bh	TSI Agent 1 temperature high byte
5Ch	TSI Agent 1 temperature low byte
5Dh	TSI Agent 2 temperature high byte
5Eh	TSI Agent 2 temperature low byte
5Fh	TSI Agent 3 temperature high byte
60h	TSI Agent 3 temperature low byte
61h	TSI Agent 4 temperature high byte
62h	TSI Agent 4 temperature low byte
63h	TSI Agent 5 temperature high byte
64h	TSI Agent 5 temperature low byte
65h	TSI Agent 6 temperature high byte
66h	TSI Agent 6 temperature low byte
67h	TSI Agent 7 temperature high byte
68h	TSI Agent 7 temperature low byte
69h	Byte Temperature high byte



ADDRESS 00-6F	DESCRIPTION
6Ah	Byte Temperature low byte
6Bh	RESERVED
6Ch	RESERVED
6Dh	RESERVED
6Eh	RESERVED
6Fh	RESERVED

9.4 SMIOVT1 Temperature Source (High Byte) Register – Index 10h (Bank 0)

Attribute: Read Only

Size: 8 bits

BIT	7	6	5	4	3	2	1	0
NAME	TEMP<8:1>							

BIT	DESCRIPTION
7-0	Temperature <8:1> (default: SYSTIN temperature source). The nine-bit value is in units of 0.5°C.

9.5 SMIOVT2 Temperature Source (High Byte) Register – Index 11h (Bank 0)

Attribute: Read Only

Size: 8 bits

BIT	7	6	5	4	3	2	1	0
NAME	TEMP<8:1>							

BIT	DESCRIPTION
7-0	Temperature <8:1> (default: CPUTIN temperature source). The nine-bit value is in units of 0.5°C.

9.6 SMIOVT3 Temperature Source (High Byte) Register – Index 12h (Bank 0)

Attribute: Read Only

Size: 8 bits

BIT	7	6	5	4	3	2	1	0
NAME	TEMP<8:1>							

BIT	DESCRIPTION
7-0	Temperature <8:1> (default: AUXTIN temperature source). The nine-bit value is in units of 0.5°C.



9.7 SMIOVT4 Temperature Source (High Byte) Register – Index 13h (Bank 0)

Attribute: Read Only

Size: 8 bits

BIT	7	6	5	4	3	2	1	0
NAME	TEMP<8:1>							

BIT	DESCRIPTION
7-0	Temperature <8:1> (default: SYSTIN temperature source). The nine-bit value is in units of 0.5°C.

9.8 SMIOVT5 Temperature Source (High Byte) Register – Index 14h (Bank 0)

Attribute: Read Only

Size: 8 bits

BIT	7	6	5	4	3	2	1	0
NAME	TEMP<8:1>							

BIT	DESCRIPTION
7-0	Temperature <8:1> (default: SYSTIN temperature source). The nine-bit value is in units of 0.5°C.

9.9 SMIOVT6 Temperature Source (High Byte) Register – Index 15h (Bank 0)

Attribute: Read Only

Size: 8 bits

BIT	7	6	5	4	3	2	1	0
NAME	TEMP<8:1>							

BIT	DESCRIPTION
7-0	Temperature <8:1> (default: SYSTIN temperature source). The nine-bit value is in units of 0.5°C.

9.10 SMIOVT1-6 Temperature Source (Low Byte) Register – Index 16h (Bank 0)

Attribute: Read Only

Size: 8 bits

BIT	7	6	5	4	3	2	1	0
NAME	Reserved.		SMIOVT6_ TEMP<0>	SMIOVT5_ TEMP<0>	SMIOVT4_ TEMP<0>	SMIOVT3_ TEMP<0>	SMIOVT2_ TEMP<0>	SMIOVT1_ TEMP<0>

BIT	DESCRIPTION
7-6	Reserved.
5	SMIOVT6 Temperature <0> (default: SYSTIN temperature source). The nine-bit value



BIT	DESCRIPTION
	is in units of 0.5°C.
4	SMIOVT5 Temperature <0> (default: SYSTIN temperature source). The nine-bit value is in units of 0.5°C.
3	SMIOVT4 Temperature <0> (default: SYSTIN temperature source). The nine-bit value is in units of 0.5°C.
2	SMIOVT3 Temperature <0> (default: AUXTIN temperature source). The nine-bit value is in units of 0.5°C.
1	SMIOVT2 Temperature <0> (default: CPUTIN temperature source). The nine-bit value is in units of 0.5°C.
0	SMIOVT1 Temperature <0> (default: SYSTIN temperature source). The nine-bit value is in units of 0.5°C.

9.11 System Fan Control Temperature Register (Integer Value)- Index 18h (Bank 0)

Attribute: Read/Write

Size: 8 bits

BIT	7	6	5	4	3	2	1	0
NAME	SysFanControlTemp [8:1]							
DEFAULT	0	0	0	0	0	0	0	0

BIT	DESCRIPTION
7-0	SysFanControlTemp [8:1] SYSFANOUT fan control temperature reading.

9.12 Cpu Fan Control Temperature Register (Integer Value)- Index 19h (Bank 0)

Attribute: Read/Write

Size: 8 bits

BIT	7	6	5	4	3	2	1	0
NAME	CpuFanControlTemp [8:1]							
DEFAULT	0	0	0	0	0	0	0	0

BIT	DESCRIPTION
7-0	CpuFanControlTemp [8:1] CPUFANOUT fan control temperature reading.

9.13 Aux Fan Control Temperature Register (Integer Value)- Index 1Ah (Bank 0)

Attribute: Read/Write

Size: 8 bits

BIT	7	6	5	4	3	2	1	0
NAME	AuxFanControlTemp [8:1]							



DEFAULT	0	0	0	0	0	0	0	0
---------	---	---	---	---	---	---	---	---

BIT	DESCRIPTION
7-0	AuxFanControlTemp [8:1] AUXFANOUT fan control temperature reading.

9.14 Fan Temperature Register (Fractional Value)- Index 1Bh (Bank 0)

Attribute: Read/Write

Size: 8 bits

BIT	7-3	2	1	0
NAME	Reserved	AuxFan ControlTemp[0]	CpuFan ControlTemp[0]	SysFan ControlTemp[0]
DEFAULT	0	0	0	0

BIT	DESCRIPTION
7-3	Reserved
2	AuxFanControlTemp[0] AuxFANOUT fan control temperature reading
1	CpuFanControlTemp[0] CpuFANOUT fan control temperature reading
0	SysFanControlTemp[0] SYSFANOUT fan control temperature reading

9.15 (SYSFANIN) FANIN1 COUNT High-byte Register – Index 20h (Bank 0)

Attribute: Read

Size: 8 bits

BIT	7	6	5	4	3	2	1	0
NAME	FANCNT1 [12:5]							
DEFAULT	0	0	0	0	0	0	0	0

BIT	DESCRIPTION
7-0	FANCNT1_H: 13-bit SYSFANIN Fan Count, High Byte

9.16 (SYSFANIN) FANIN1 COUNT Low-byte Register – Index 21h (Bank 0)

Attribute: Read

Size: 8 bits

BIT	7	6	5	4	3	2	1	0
NAME	RESERVED			FANCNT1 [4:0]				



DEFAULT	0	0
---------	---	---

9.17 (CPUFANIN) FANIN2 COUNT High-byte Register – Index 22h (Bank 0)

Attribute: Read

Size: 8 bits

BIT	7	6	5	4	3	2	1	0
NAME	FANCNT2 [12:5]							
DEFAULT	0	0	0	0	0	0	0	0

BIT	DESCRIPTION
7-0	FANCNT2_H: 13-bit CPUFANIN Fan Count, High Byte

9.18 (CPUFANIN) FANIN2 COUNT Low-byte Register – Index 23h (Bank 0)

Attribute: Read

Size: 8 bits

BIT	7	6	5	4	3	2	1	0
NAME	RESERVED			FANCNT2[4:0]				
DEFAULT	0			0				

BIT	DESCRIPTION
7-5	Reserved.
4-0	FANCNT2_L: 13-bit CPUFANIN Fan Count, Low Byte

9.19 (AUXFANIN) FANIN3 COUNT High-byte Register – Index 24h (Bank 0)

Attribute: Read

Size: 8 bits

BIT	7	6	5	4	3	2	1	0
NAME	FANCNT3 [12:5]							
DEFAULT	0	0	0	0	0	0	0	0

BIT	DESCRIPTION
7-0	FANCNT3_H: 13-bit AUXFANIN Fan Count, High Byte

9.20 (AUXFANIN) FANIN3 COUNT Low-byte Register – Index 25h (Bank 0)

Attribute: Read

Size: 8 bits

BIT	7	6	5	4	3	2	1	0
NAME	RESERVED			FANCNT3 [4:0]				



DEFAULT	0	0
---------	---	---

BIT	DESCRIPTION
7-5	Reserved.
4-0	FANCNT3_L: 13-bit AUXFANIN Fan Count, Low Byte

9.21 Bank Select Register – Index 4Eh (Bank 0)

Attribute: Read/Write

Size: 8 bits

BIT	7	6	5	4	3	2	1	0
NAME	HBACS	Reserved					BANK SEL1	BANK SELO
DEFAULT	1	0	0	0	0	0	0	0

BIT	DESCRIPTION
7	HBACS. HBACS – High Byte Access. 1: Access Index 4Fh high-byte register. (Default) 0: Access Index 4Fh low-byte register.
6-2	RESERVED
1	BANKSEL1.
0	BANKSELO.

Bank Select for Bank0 to Bank3. The Two - bit binary value corresponds to the bank number. For example, "01" selects bank1.

9.22 PORT 80 DATA INPUT Register – Index 4F (Bank 0)

Attribute: Read

Size: 8 bits

BIT	7	6	5	4	3	2	1	0
NAME	P80_IN							
DEFAULT	0	0	0	0	0	0	0	0

BIT	DESCRIPTION
7-0	PORT 80 DATA INPUT

9.23 PCH_CHIP_CPU_MAX_TEMP Register – Index 50h (Bank 0)

Attribute: Read

Size: 8 bits

BIT	7	6	5	4	3	2	1	0
NAME	PCH_CHIP_CPU_MAX_TEMP							
DEFAULT	0	0	0	0	0	0	0	0



BIT	DESCRIPTION
7-0	PCH_CHIP_CPU_MAX_TEMP: The maximum temperature in absolute degree C, of the CPU and MCH.

9.24 PCH_CHIP_TEMP Register – Index 51h (Bank 0)

Attribute: Read

Size: 8 bits

BIT	7	6	5	4	3	2	1	0
NAME	PCH_CHIP_TEMP							
DEFAULT	0	0	0	0	0	0	0	0

BIT	DESCRIPTION
7-0	PCH_CHIP_TEMP The IBX_CHIP temperature in degree C.

9.25 PCH_CPU_TEMP_H Register – Index 52h (Bank 0)

Attribute: Read

Size: 8 bits

BIT	7	6	5	4	3	2	1	0
NAME	PCH_CPU_TEMP_H							
DEFAULT	0	0	0	0	0	0	0	0

BIT	DESCRIPTION
7-0	PCH_CPU_TEMP_H The CPU temperature in degree C. (Integer Part)

9.26 PCH_CPU_TEMP_L Register – Index 53h (Bank 0)

Attribute: Read

Size: 8 bits

BIT	7	6	5	4	3	2	1	0
NAME	PCH_CPU_TEMP_L						Reserved	Reading _Flag
DEFAULT	0	0	0	0	0	0	0	0

BIT	DESCRIPTION
7-2	PCH_CPU_TEMP_L The CPU temperature in degree C. (Fractional Part)
1	Reserved
0	Reading_Flag: If there is an error when the IBX read the data from the CPU, then Bit0 is set to '1'.

9.27 PCH_MCH_TEMP Register – Index 54h (Bank 0)



Attribute: Read

Size: 8 bits

BIT	7	6	5	4	3	2	1	0
NAME	PCH_MCH_TEMP							
DEFAULT	0	0	0	0	0	0	0	0

BIT	DESCRIPTION							
7-0	PCH_MCH_TEMP	The MCH temperature in degree C.						

9.28 PCH_DIM0_TEMP Register – Index 55h (Bank 0)

Attribute: Read

Size: 8 bits

BIT	7	6	5	4	3	2	1	0
NAME	PCH_DIM0_TEMP							
DEFAULT	0	0	0	0	0	0	0	0

BIT	DESCRIPTION							
7-0	PCH_DIM0_TEMP	The DIM0 temperature in degree C.						

9.29 PCH_DIM1_TEMP Register – Index 56h (Bank 0)

Attribute: Read

Size: 8 bits

BIT	7	6	5	4	3	2	1	0
NAME	PCH_DIM1_TEMP							
DEFAULT	0	0	0	0	0	0	0	0

BIT	DESCRIPTION							
7-0	PCH_DIM1_TEMP	The DIM1 temperature in degree C.						

9.30 PCH_DIM2_TEMP Register – Index 57h (Bank 0)

Attribute: Read

Size: 8 bits

BIT	7	6	5	4	3	2	1	0
NAME	PCH_DIM2_TEMP							
DEFAULT	0	0	0	0	0	0	0	0

BIT	DESCRIPTION							
7-0	PCH_DIM2_TEMP	The DIM2 temperature in degree C.						



9.31 PCH_DIM3_TEMP Register – Index 58h (Bank 0)

Attribute: Read

Size: 8 bits

BIT	7	6	5	4	3	2	1	0
NAME	PCH_DIM3_TEMP							
DEFAULT	0	0	0	0	0	0	0	0

BIT	DESCRIPTION
7-0	PCH_DIM3_TEMP The DIM3 temperature in degree C.

9.32 PCH_TSI0_TEMP_H Register – Index 59h (Bank 0)

Attribute: Read

Size: 8 bits

BIT	7	6	5	4	3	2	1	0
NAME	PCH_TSI0_TEMP_H							
DEFAULT	0	0	0	0	0	0	0	0

BIT	DESCRIPTION
7-0	PCH_TSI0_TEMP_H The TSI High-Byte temperature in degree C.

9.33 PCH_TSI0_TEMP_L Register – Index 5Ah (Bank 0)

Attribute: Read

Size: 8 bits

BIT	7	6	5	4	3	2	1	0
NAME	PCH_TSI0_TEMP_L			Reserved				
DEFAULT	0	0	0	0	0	0	0	0

BIT	DESCRIPTION
7-5	PCH_TSI0_TEMP_L The TSI Low-Byte temperature in degree C.
4-0	Reserved

9.34 PCH_TSI1_TEMP_H Register – Index 5Bh (Bank 0)

Attribute: Read

Size: 8 bits

BIT	7	6	5	4	3	2	1	0
NAME	PCH_TSI1_TEMP_H							
DEFAULT	0	0	0	0	0	0	0	0



BIT	DESCRIPTION
7-0	PCH_TSI1_TEMP_H The TSI High-Byte temperature in degree C.

9.35 PCH_TSI1_TEMP_L Register – Index 5Ch (Bank 0)

Attribute: Read

Size: 8 bits

BIT	7	6	5	4	3	2	1	0
NAME	PCH_TSI1_TEMP_L				Reserved			
DEFAULT	0	0	0	0	0	0	0	0

BIT	DESCRIPTION
7-5	PCH_TSI1_TEMP_L The TSI Low-Byte temperature in degree C.
4-0	Reserved

9.36 PCH_TSI2_TEMP_H Register – Index 5Dh (Bank 0)

Attribute: Read

Size: 8 bits

BIT	7	6	5	4	3	2	1	0
NAME	PCH_TSI2_TEMP_H							
DEFAULT	0	0	0	0	0	0	0	0

BIT	DESCRIPTION
7-0	PCH_TSI2_TEMP_H The TSI High-Byte temperature in degree C.

9.37 PCH_TSI2_TEMP_L Register – Index 5Eh (Bank 0)

Attribute: Read

Size: 8 bits

BIT	7	6	5	4	3	2	1	0
NAME	PCH_TSI2_TEMP_L				Reserved			
DEFAULT	0	0	0	0	0	0	0	0

BIT	DESCRIPTION
7-5	PCH_TSI2_TEMP_L The TSI Low-Byte temperature in degree C.
4-0	Reserved

9.38 PCH_TSI3_TEMP_H Register – Index 5Fh (Bank 0)

Attribute: Read

Size: 8 bits



BIT	7	6	5	4	3	2	1	0
NAME	PCH_TSI3_TEMP_H							
DEFAULT	0	0	0	0	0	0	0	0

BIT	DESCRIPTION
7-0	PCH_TSI3_TEMP_H The TSI High-Byte temperature in degree C.

9.39 PCH_TSI3_TEMP_L Register – Index 60h (Bank 0)

Attribute: Read

Size: 8 bits

BIT	7	6	5	4	3	2	1	0
NAME	PCH_TSI3_TEMP_L				Reserved			
DEFAULT	0	0	0	0	0	0	0	0

BIT	DESCRIPTION
7-5	PCH_TSI3_TEMP_L The TSI Low-Byte temperature in degree C.
4-0	Reserved

9.40 PCH_TSI4_TEMP_H Register – Index 61h (Bank 0)

Attribute: Read

Size: 8 bits

BIT	7	6	5	4	3	2	1	0
NAME	PCH_TSI4_TEMP_H							
DEFAULT	0	0	0	0	0	0	0	0

BIT	DESCRIPTION
7-0	PCH_TSI4_TEMP_H The TSI High-Byte temperature in degree C.

9.41 PCH_TSI4_TEMP_L Register – Index 62h (Bank 0)

Attribute: Read

Size: 8 bits

BIT	7	6	5	4	3	2	1	0
NAME	PCH_TSI4_TEMP_L				Reserved			
DEFAULT	0	0	0	0	0	0	0	0

BIT	DESCRIPTION
7-5	PCH_TSI4_TEMP_L The TSI Low-Byte temperature in degree C.
4-0	Reserved



9.42 PCH_TSI5_TEMP_H Register – Index 63h (Bank 0)

Attribute: Read

Size: 8 bits

BIT	7	6	5	4	3	2	1	0
NAME	PCH_TSI5_TEMP_H							
DEFAULT	0	0	0	0	0	0	0	0

BIT	DESCRIPTION
7-0	PCH_TSI5_TEMP_H The TSI High-Byte temperature in degree C.

9.43 PCH_TSI5_TEMP_L Register – Index 64h (Bank 0)

Attribute: Read

Size: 8 bits

BIT	7	6	5	4	3	2	1	0
NAME	PCH_TSI5_TEMP_L			Reserved				
DEFAULT	0	0	0	0	0	0	0	0

BIT	DESCRIPTION
7-5	PCH_TSI5_TEMP_L The TSI Low-Byte temperature in degree C.
4-0	Reserved

9.44 PCH_TSI6_TEMP_H Register – Index 65h (Bank 0)

Attribute: Read

Size: 8 bits

BIT	7	6	5	4	3	2	1	0
NAME	PCH_TSI6_TEMP_H							
DEFAULT	0	0	0	0	0	0	0	0

BIT	DESCRIPTION
7-0	PCH_TSI6_TEMP_H The TSI High-Byte temperature in degree C.

9.45 PCH_TSI6_TEMP_L Register – Index 66h (Bank 0)

Attribute: Read

Size: 8 bits

BIT	7	6	5	4	3	2	1	0
NAME	PCH_TSI6_TEMP_L			Reserved				
DEFAULT	0	0	0	0	0	0	0	0



BIT	DESCRIPTION
7-5	PCH_TSI6_TEMP_L The TSI Low-Byte temperature in degree C.
4-0	Reserved

9.46 PCH_TSI7_TEMP_H Register – Index 67h (Bank 0)

Attribute: Read

Size: 8 bits

BIT	7	6	5	4	3	2	1	0
NAME	PCH_TSI7_TEMP_H							
DEFAULT	0	0	0	0	0	0	0	0

BIT	DESCRIPTION
7-0	PCH_TSI7_TEMP_H The TSI High-Byte temperature in degree C.

9.47 PCH_TSI7_TEMP_L Register – Index 68h (Bank 0)

Attribute: Read

Size: 8 bits

BIT	7	6	5	4	3	2	1	0
NAME	PCH_TSI7_TEMP_L			Reserved				
DEFAULT	0	0	0	0	0	0	0	0

BIT	DESCRIPTION
7-5	PCH_TSI7_TEMP_L The TSI Low-Byte temperature in degree C.
4-0	Reserved

9.48 ByteTemp_H Register – Index 69h (Bank 0)

Attribute: Read

Size: 8 bits

BIT	7	6	5	4	3	2	1	0
NAME	ByteTemp_H							
DEFAULT	0	0	0	0	0	0	0	0

BIT	DESCRIPTION
7-0	ByteTemp_H The TSI Byte format High-Byte temperature in degree C.

9.49 ByteTemp_L Register – Index 6Ah (Bank 0)

Attribute: Read

Size: 8 bits



BIT	7	6	5	4	3	2	1	0
NAME	ByteTemp_L							
DEFAULT	0	0	0	0	0	0	0	0

BIT	DESCRIPTION
7-0	ByteTemp_L The TSI Byte format Low-Byte temperature in degree C.

9.50 Peci Temp Register – Index 6Bh (Bank 0)

Attribute: Read

Size: 8 bits

BIT	7	6	5	4	3	2	1	0
NAME	Peci Temp							
DEFAULT	0	0	0	0	0	0	0	0

BIT	DESCRIPTION
7-0	ByteTemp_L The TSI Byte format Low-Byte temperature in degree C.

9.51 Interrupt Status Register 1 – Index 70h (Bank 0)

Attribute: Read Only

Size: 8 bits

BIT	7	6	5	4	3	2	1	0
NAME	3VSB	RESERVED	VIN2	VIN1	3VCC	AVCC	VIN0	CPUVCORE
DEFAULT	0	0	0	0	0	0	0	0

BIT	DESCRIPTION
7	3VSB. A one indicates the high or low limit of 3VSB has been exceeded.
6	RESERVED
5	VIN2. A one indicates the high or low limit of VIN2 has been exceeded
4	VIN1. A one indicates the high or low limit of VIN1 has been exceeded
3	3VCC. A one indicates the high or low limit of 3VCC has been exceeded.
2	AVCC . A one indicates the high or low limit of AVCC has been exceeded.
1	VIN0. A one indicates the high or low limit of VIN0 has been exceeded.
0	CPUVCORE. A one indicates the high or low limit of CPUVCORE has been exceeded.

9.52 Interrupt Status Register 2 – Index 71h (Bank 0)

Attribute: Read Only

Size: 8 bits

BIT	7	6	5	4	3	2	1	0
-----	---	---	---	---	---	---	---	---



NAME	RESERVED						V10	VBAT
DEFAULT	0	0	0	0	0	0	0	

BIT	DESCRIPTION
7	RESERVED
6	RESERVED
5	RESERVED
4	RESERVED
3	RESERVED
2	RESERVED
1	V10. A one indicates the high or low limit of V10 has been exceeded.
0	VBATone indicates the high or low limit of VBAT has been exceeded.

9.53 Interrupt Status Register 3 – Index 72h (Bank 0)

Attribute: Read Only

Size: 8 bits

BIT	7	6	5	4	3	2	1	0
NAME	RESERVED	RESERVED	SOURCE6_SMI	SOURCE5_SMI	SOURCE4_SMI	SOURCE3_SMI	SOURCE2_SMI	SOURCE1_SMI
DEFAULT	0	0	0	0	0	0	0	0

BIT	DESCRIPTION
7	RESERVED
6	RESERVED
5	SOURCE6_SMI. A one indicates the high limit of SMIOVT SOURCE6 temperature has been exceeded. (SYSTIN is default temperature)
4	SOURCE5_SMI. A one indicates the high limit of SMIOVT SOURCE5 temperature has been exceeded. (SYSTIN is default temperature)
3	SOURCE4_SMI. A one indicates the high limit of SMIOVT SOURCE4 temperature has been exceeded. (SYSTIN is default temperature)
2	SOURCE3_SMI. A one indicates the high limit of SMIOVT SOURCE3 temperature has been exceeded. (AUXTIN is default temperature)
1	SOURCE2_SMI. A one indicates the high limit of SMIOVT SOURCE2 temperature has been exceeded. (CPUTIN is default temperature)
0	SOURCE1_SMI. A one indicates the high limit of SMIOVT SOURCE1 temperature has been exceeded. (SYSTIN is default temperature)



9.54 Interrupt Status Register 4 – Index 73h (Bank 0)

Attribute: Read Only

Size: 8 bits

BIT	7	6	5	4	3	2	1	0
NAME	RESERVE D	RESERVE D	Shut_ SOURCE6 _SMI	Shut_ SOURCE5 _SMI	Shut_ SOURCE4 _SMI	Shut_ SOURCE3 _SMI	Shut_ SOURCE2 _SMI	Shut_ SOURCE1 _SMI
DEFAULT	0	0	0	0	0	0	0	0

BIT	DESCRIPTION
7	RESERVED
6	RESERVED
5	Shut_SOURCE6_SMI. “1” indicates the high limit of SMIOVT_SOURCE6 temperature of SMI# Shut-down mode has been exceeded. (SYSTIN is default temperature)
4	Shut_SOURCE5_SMI. “1” indicates the high limit of SMIOVT_SOURCE5 temperature of SMI# Shut-down mode has been exceeded. (SYSTIN is default temperature)
3	Shut_SOURCE4_SMI. “1” indicates the high limit of SMIOVT_SOURCE4 temperature of SMI# Shut-down mode has been exceeded. (SYSTIN is default temperature)
2	Shut_SOURCE3_SMI. “1” indicates the high limit of SMIOVT_SOURCE3 temperature of SMI# Shut-down mode has been exceeded. (AUXTIN is default temperature)
1	Shut_SOURCE2_SMI. “1” indicates the high limit of SMIOVT_SOURCE2 temperature of SMI# Shut-down mode has been exceeded. (CPUTIN is default temperature)
0	Shut_SOURCE1_SMI. “1” indicates the high limit of SMIOVT_SOURCE1 temperature of SMI# Shut-down mode has been exceeded. (SYSTIN is default temperature)

9.55 Interrupt Status Register 5 – Index 74h (Bank 0)

Attribute: Read Only

Size: 8 bits

BIT	7	6	5	4	3	2	1	0
NAME	RESERVE D	RESERVE D	RESERVE D	RESERVE D	RESERVE D	AUXFANI N	CPUFANI N	SYSFANI N
DEFAULT	0	0	0	0	0	0	0	0

BIT	DESCRIPTION
7	RESERVED
6	RESERVED
5	RESERVED
4	RESERVED
3	RESERVED
2	AUXFANIN. A one indicates the fan count limit of AUXFANIN has been exceeded.
1	CPUFANIN. A one indicates the fan count limit of CPUFANIN has been exceeded.
0	SYSFANIN. A one indicates the fan count limit of SYSFANIN has been exceeded.



9.56 Interrupt Status Register 6 – Index 75h (Bank 0)

Attribute: Read Only

Size: 8 bits

BIT	7	6	5	4	3	2	1	0
NAME	RESERVE D	RESERVE D	RESERVE D	RESERVE D	RESERVE D	AUX FANOUT	CPU FANOUT	SYS FANOUT
DEFAULT	0	0	0	0	0	0	0	0

BIT	DESCRIPTION
7	RESERVED
6	RESERVED
5	RESERVED
4	RESERVED
3	RESERVED
2	AUXFANOUT. “1” indicates that AUXFANOUT works for three minutes at the full fan speed.
1	CPUFANOUT. “1” indicates that CPUFANOUT works for three minutes at the full fan speed.
0	SYSFANOUT. “1” indicates that SYSFANOUT works for three minutes at the full fan speed.

9.57 Interrupt Status Register 7 – Index 76h (Bank 0)

Attribute: Read Only

Size: 8 bits

BIT	7	6	5	4	3	2	1	0
NAME	RESERVE D	RESERVE D	RESERVE D	RESERVE D	RESERVE D	RESERVE D	RESERVE D	CASEOPE N1
DEFAULT	0	0	0	0	0	0	0	0

BIT	DESCRIPTION
7	RESERVED
6	RESERVED
5	RESERVED
4	RESERVED
3	RESERVED
2	RESERVED
1	RESERVED
0	CASEOPEN1. A one indicates the case has been opened.

9.58 Real Time Status Register 1 – Index 77h (Bank 0)

Attribute: Read Only

Size: 8 bits



BIT	7	6	5	4	3	2	1	0
NAME	3VSB_STSTS	RESERVED	VIN2_STSTS	VIN1_STSTS	3VCC_STSTS	AVCC_STSTS	VIN0_STSTS	CPUVCORE_STSTS
DEFAULT	0	0	0	0	0	0	0	0

BIT	DESCRIPTION
7	3VSB_STSTS. 1: 3VSB voltage is over or under the allowed range. 0: 3VSB voltage is in the allowed range.
6	RESERVED
5	VIN2_STSTS. 1: VIN2 voltage is over or under the allowed range. 0: VIN2 voltage is in the allowed range.
4	VIN1_STSTS. 1: VIN1 voltage is over or under the allowed range. 0: VIN1 voltage is in the allowed range.
3	3VCC_STSTS. 1: 3VCC voltage is over or under the allowed range. 0: 3VCC voltage is in the allowed range.
2	AVCC_STSTS. 1: AVCC voltage is over or under the allowed range. 0: AVCC voltage is in the allowed range.
1	VIN0_STSTS. 1: VIN0 voltage is over or under the allowed range. 0: VIN0 voltage is in the allowed range.
0	CPUVCORE_STSTS. 1: CPUVCORE voltage is over or under the allowed range. 0: CPUVCORE voltage is in the allowed range.

9.59 Real Time Status Register 2 – Index 78h (Bank 0)

Attribute: Read Only

Size: 8 bits

BIT	7	6	5	4	3	2	1	0
NAME	RESERVED	RESERVED	RESERVED	RESERVED	RESERVED	RESERVED	V10_STSTS	VBAT_STSTS
DEFAULT	0	0	0	0	0	0	0	0

BIT	DESCRIPTION
7	RESERVED
6	RESERVED
5	RESERVED
4	RESERVED
3	RESERVED



BIT	DESCRIPTION
2	RESERVED.
1	V10_STS. 1: V10 voltage is over or under the allowed range. 0: V10 voltage is in the allowed range.
0	VBAT_STS. 1: VBAT voltage is over or under the allowed range. 0: VBAT voltage is in the allowed range.

9.60 Real Time Status Register 3 – Index 79h (Bank 0)

Attribute: Read Only

Size: 8 bits

BIT	7	6	5	4	3	2	1	0
NAME	RESERVED	RESERVED	SMIOVT6_STS	SMIOVT5_STS	SMIOVT4_STS	SMIOVT3_STS	SMIOVT2_STS	SMIOVT1_STS
DEFAULT	0	0	0	0	0	0	0	0

BIT	DESCRIPTION
7	RESERVED
6	RESERVED
5	SMIOVT6_STS. 1: SMIOVT6 Temperature exceeds the over-temperature value. 0: SMIOVT6 Temperature is under the hysteresis value.
4	SMIOVT5_STS. 1: SMIOVT5 Temperature exceeds the over-temperature value. 0: SMIOVT5 Temperature is under the hysteresis value.
3	SMIOVT4_STS. 1: SMIOVT4 Temperature exceeds the over-temperature value. 0: SMIOVT4 Temperature is under the hysteresis value.
2	SMIOVT3_STS. 1: SMIOVT3 Temperature exceeds the over-temperature value. 0: SMIOVT3 Temperature is under the hysteresis value.
1	SMIOVT2_STS. 1: SMIOVT2 Temperature exceeds the over-temperature value. 0: SMIOVT2 Temperature is under the hysteresis value.
0	SMIOVT1_STS. 1: SMIOVT1 Temperature exceeds the over-temperature value. 0: SMIOVT1 Temperature is under the hysteresis value.

9.61 Real Time Status Register 4 – Index 7Ah (Bank 0)

Attribute: Read Only

Size: 8 bits

BIT	7	6	5	4	3	2	1	0



NAME	RESERVED	RESERVED	Shut_ SMIOVT6 _STS	Shut_ SMIOVT5 _STS	Shut_ SMIOVT4 _STS	Shut_ SMIOVT3 _STS	Shut_ SMIOVT2 _STS	Shut_ SMIOVT1 _STS
DEFAULT	0	0	0	0	0	0	0	0

BIT	DESCRIPTION
7	RESERVED
6	RESERVED
5	Shut_SMIOVT6_STS. 1: SMIOVT6 Temperature exceeds the Shut -temperature value. 0: SMIOVT6 Temperature is under the Shut-hysteresis value.
4	Shut_SMIOVT5_STS. 1: SMIOVT5 Temperature exceeds the Shut -temperature value. 0: SMIOVT5 Temperature is under the Shut-hysteresis value.
3	Shut_SMIOVT4_STS. 1: SMIOVT4 Temperature exceeds the Shut -temperature value. 0: SMIOVT4 Temperature is under the Shut-hysteresis value.
2	Shut_SMIOVT3_STS. 1: SMIOVT3 Temperature exceeds the Shut -temperature value. 0: SMIOVT3 Temperature is under the Shut-hysteresis value.
1	Shut_SMIOVT2_STS. 1: SMIOVT2 Temperature exceeds the Shut -temperature value. 0: SMIOVT2 Temperature is under the Shut-hysteresis value.
0	Shut_SMIOVT1_STS. 1: SMIOVT1 Temperature exceeds the Shut -temperature value. 0: SMIOVT1 Temperature is under the Shut-hysteresis value.

9.62 Real Time Status Register 5 – Index 7Bh (Bank 0)

Attribute: Read Only

Size: 8 bits

BIT	7	6	5	4	3	2	1	0
NAME	RESERVED	RESERVED	RESERVED	RESERVED	RESERVED	AUX FANIN _STS	CPU FANIN _STS	SYS FANIN _STS
DEFAULT	0	0	0	0	0	0	0	0

BIT	DESCRIPTION
7	RESERVED
6	RESERVED
5	RESERVED
4	RESERVED
3	RESERVED
2	AUXFANIN_STS.



BIT	DESCRIPTION
	1: Fan speed count is over the threshold value. 0: Fan speed count is in the allowed range.
1	CPUFANIN_STS. 1: Fan speed count is over the threshold value. 0: Fan speed count is in the allowed range.
0	SYSFANIN_STS. 1: Fan speed count is over the threshold value. 0: Fan speed count is in the allowed range.

9.63 Real Time Status Register 6 – Index 7Ch (Bank 0)

Attribute: Read Only

Size: 8 bits

BIT	7	6	5	4	3	2	1	0
NAME	RESERVED	RESERVED	RESERVED	RESERVED	RESERVED	AUX FANOUT _STS	CPU FANOUT _STS	SYS FANOUT _STS
DEFAULT	0	0	0	0	0	0	0	0

BIT	DESCRIPTION
7	RESERVED
6	RESERVED
5	RESERVED
4	RESERVED
3	RESERVED
2	AUXFANOUT_STS. 1: The selected temperature has been over the target temperature for three minutes at full fan speed in Thermal Cruise Mode. 0: The selected temperature has not reached the warning range.
1	CPUFANOUT_STS. 1: The selected temperature has been over the target temperature for three minutes at full fan speed in Thermal Cruise Mode. 0: The selected temperature has not reached the warning range.
0	SYSFANOUT_STS. 1: The selected temperature has been over the target temperature for three minutes at full fan speed in Thermal Cruise Mode. 0: The selected temperature has not reached the warning range.

9.64 Real Time Status Register 7 – Index 7Dh (Bank 0)

Attribute: Read Only

Size: 8 bits

BIT	7	6	5	4	3	2	1	0
NAME	RESERVED							Caseopen_STS



DEFAULT	0	0	0	0	0	0	0	0
---------	---	---	---	---	---	---	---	---

BIT	DESCRIPTION
7	RESERVED
6	RESERVED
5	RESERVED
4	RESERVED
3	RESERVED
2	RESERVED
1	RESERVED
0	CASEOPEN_STS. 1: Caseopen is detected and latched. 0: Caseopen is not latched.

9.65 Reserved Register – Index 7Eh ~ 7Fh (Bank 0)

9.66 SMI# Mask Register 1 – Index 80h (Bank 0)

Attribute: Read/Write

Size: 8 bits

BIT	7	6	5	4	3	2	1	0
NAME	3VSB	RESERVED	VIN2	VIN1	3VCC	AVCC	VIN0	CPUVCORE
DEFAULT	1	1	1	1	1	1	1	1

BIT	DESCRIPTION
7	3VSB.
6	RESERVED
5	VIN2.
4	VIN1.
3	3VCC.
2	AVCC.
1	VIN0.
0	CPUVCORE.

A one disables the corresponding interrupt status bit for the SMI interrupt. (See Interrupt Status Register 1 – Index 70h (Bank0))

9.67 SMI# Mask Register 2 – Index 81h (Bank 0)

Attribute: Read/Write

Size: 8 bits

BIT	7	6	5	4	3	2	1	0
NAME	RESERVED	RESERVED	RESERVED	RESERVED	RESERVED	RESERVED	V10	VBAT
DEFAULT	0	0	0	0	0	0	1	1



BIT	DESCRIPTION	
7	RESERVED.	A <u>one</u> disables the corresponding interrupt status bit for the SMI interrupt. (See Interrupt Status Register 2 – Index 71h (Bank0))
6	RESERVED.	
5	RESERVED.	
4	RESERVED.	
3	RESERVED.	
2	RESERVED.	
1	V10.	
0	VBAT.	

9.68 SMI# Mask Register 3 – Index 82h (Bank 0)

Attribute: Read/Write

Size: 8 bits

BIT	7	6	5	4	3	2	1	0
NAME	RESERVED	RESERVED	SMIOVT6	SMIOVT5	SMIOVT4	SMIOVT3	SMIOVT2	SMIOVT1
DEFAULT	0	0	1	1	1	1	1	1

BIT	DESCRIPTION	
7	RESERVED.	A <u>one</u> disables the corresponding interrupt status bit for the SMI interrupt. (See Interrupt Status Register 3 – Index 72h (Bank0))
6	RESERVED.	
5	SMIOVT6.	
4	SMIOVT5.	
3	SMIOVT4.	
2	SMIOVT3.	
1	SMIOVT2.	
0	SMIOVT1.	

9.69 SMI# Mask Register 4 – Index 83h (Bank 0)

Attribute: Read/Write

Size: 8 bits

BIT	7	6	5	4	3	2	1	0
NAME	RESERVED	RESERVED	Shut_ SMIOVT6	Shut_ SMIOVT5	Shut_ SMIOVT4	Shut_ SMIOVT3	Shut_ SMIOVT2	Shut_ SMIOVT1
DEFAULT	0	0	1	1	1	1	1	1

BIT	DESCRIPTION	
7	RESERVED.	A <u>one</u> disables the corresponding interrupt status bit for the SMI interrupt. (See Interrupt Status Register 4 – Index 73h (Bank0))
6	RESERVED.	
5	Shut_ SMIOVT6.	
4	Shut_ SMIOVT5.	



BIT	DESCRIPTION	
3	Shut_SMIOVT4.	
2	Shut_SMIOVT3.	
1	Shut_SMIOVT2.	
0	Shut_SMIOVT1.	

9.70 SMI# Mask Register 5 – Index 84h (Bank 0)

Attribute: Read/Write

Size: 8 bits

BIT	7	6	5	4	3	2	1	0
NAME	RESERVED	RESERVED	RESERVED	RESERVED	RESERVED	AUX FANIN	CPU FANIN	SYS FANIN
DEFAULT	0	0	1	1	1	1	1	1

BIT	DESCRIPTION	
7	RESERVED.	A <u>one</u> disables the corresponding interrupt status bit for the SMI interrupt. (See Interrupt Status Register 5 – Index 74h (Bank0))
6	RESERVED.	
5	RESERVED.	
4	RESERVED.	
3	RESERVED.	
2	AUXFANIN.	
1	CPUFANIN.	
0	SYSFANIN.	

9.71 SMI# Mask Register 6 – Index 85h (Bank 0)

Attribute: Read/Write

Size: 8 bits

BIT	7	6	5	4	3	2	1	0
NAME	RESERVED					AUX FANOUT	CPU FANOUT	SYS FANOUT
DEFAULT	0	0	0	0	0	1	1	1

BIT	DESCRIPTION	
7	RESERVED.	A <u>one</u> disables the corresponding interrupt status bit for the SMI interrupt. (See Interrupt Status Register 6 – Index 75h (Bank0))
6	RESERVED.	
5	RESERVED.	
4	RESERVED.	
3	RESERVED.	
2	AUXFANOUT.	
1	CPUFANOUT.	



BIT	DESCRIPTION
0	SYSFANOUT.

9.72 SMI# Mask Register 7 – Index 86h (Bank 0)

Attribute: Read/Write

Size: 8 bits

BIT	7	6	5	4	3	2	1	0
NAME	RESERVED					Caseopen_clr	RESERVED	Caseopen
DEFAULT	0	0	0	0	0	0	0	1

BIT	DESCRIPTION
7	RESERVED.
6	RESERVED.
5	RESERVED.
4	RESERVED.
3	RESERVED.
2	Caseopen_clr.
1	RESERVED.
0	Caseopen.

A one disables the corresponding interrupt status bit for the SMI interrupt. (See Interrupt Status Register 7 – Index 76h (Bank0))

9.73 CPUVCORE High Limit Voltage Register – Index 90h (Bank 0)

Attribute: Read/Write

Size: 8 bits

BIT	7	6	5	4	3	2	1	0
NAME	CPUVCORE High Limit Voltage							
DEFAULT	1	1	0	1	1	0	1	0

BIT	DESCRIPTION
7-0	CPUVCORE High Limit Voltage. Default: 0xDAh

9.74 CPUVCORE Low Limit Voltage Register – Index 91h (Bank 0)

Attribute: Read/Write

Size: 8 bits

BIT	7	6	5	4	3	2	1	0
NAME	CPUVCORE High Limit Voltage							
DEFAULT	0	0	0	0	0	0	1	0

BIT	DESCRIPTION
-----	-------------



7-0	CPUVCORE Low Limit Voltage. Default: 0x00h
-----	---

9.75 VIN0 High Limit Voltage Register – Index 92h (Bank 0)

Attribute: Read/Write

Size: 8 bits

BIT	7	6	5	4	3	2	1	0
NAME	VIN0 High Limit Voltage							
DEFAULT	0	0	0	0	0	0	1	0

BIT	DESCRIPTION
7-0	VIN0 High Limit Voltage. Default: 0xFFh

9.76 VIN1 Low Limit Voltage Register – Index 93h (Bank 0)

Attribute: Read/Write

Size: 8 bits

BIT	7	6	5	4	3	2	1	0
NAME	VIN1 Low Limit Voltage							
DEFAULT	0	0	0	0	0	0	1	0

BIT	DESCRIPTION
7-0	VIN0 Low Limit Voltage. Default: 0x00h

9.77 AVCC High Limit Voltage Register – Index 94h (Bank 0)

Attribute: Read/Write

Size: 8 bits

BIT	7	6	5	4	3	2	1	0
NAME	AVCC High Limit Voltage							
DEFAULT	0	0	0	0	0	0	1	0

BIT	DESCRIPTION
7-0	AVCC High Limit Voltage. Default: 0xFFh

9.78 AVCC Low Limit Voltage Register – Index 95h (Bank 0)

Attribute: Read/Write

Size: 8 bits

BIT	7	6	5	4	3	2	1	0
NAME	AVCC Low Limit Voltage							
DEFAULT	0	0	0	0	0	0	1	0



BIT	DESCRIPTION
7-0	AVCC Low Limit Voltage. Default: 0x00h

9.79 3VCC High Limit Voltage Register – Index 96h (Bank 0)

Attribute: Read/Write

Size: 8 bits

BIT	7	6	5	4	3	2	1	0
NAME	3VCC High Limit Voltage							
DEFAULT	0	0	0	0	0	0	1	0

BIT	DESCRIPTION
7-0	3VCC High Limit Voltage. Default: 0xFFh

9.80 3VCC Low Limit Voltage Register – Index 97h (Bank 0)

Attribute: Read/Write

Size: 8 bits

BIT	7	6	5	4	3	2	1	0
NAME	3VCC Low Limit Voltage							
DEFAULT	0	0	0	0	0	0	1	0

BIT	DESCRIPTION
7-0	3VCC Low Limit Voltage. Default: 0x00h

9.81 VIN1 High Limit Voltage Register – Index 98h (Bank 0)

Attribute: Read/Write

Size: 8 bits

BIT	7	6	5	4	3	2	1	0
NAME	VIN1 High Limit Voltage							
DEFAULT	0	0	0	0	0	0	1	0

BIT	DESCRIPTION
7-0	VIN1 High Limit Voltage. Default: 0xFFh

9.82 VIN1 Low Limit Voltage Register – Index 99h (Bank 0)

Attribute: Read/Write

Size: 8 bits

BIT	7	6	5	4	3	2	1	0
-----	---	---	---	---	---	---	---	---



NAME	VIN1 Low Limit Voltage							
DEFAULT	0	0	0	0	0	0	1	0

BIT	DESCRIPTION
7-0	VIN1 Low Limit Voltage. Default: 0x00h

9.83 VIN2 High Limit Voltage Register – Index 9Ah (Bank 0)

Attribute: Read/Write

Size: 8 bits

BIT	7	6	5	4	3	2	1	0
NAME	VIN2 High Limit Voltage							
DEFAULT	0	0	0	0	0	0	1	0

BIT	DESCRIPTION
7-0	VIN2 High Limit Voltage. Default: 0xFFh

9.84 VIN2 Low Limit Voltage Register – Index 9Bh (Bank 0)

Attribute: Read/Write

Size: 8 bits

BIT	7	6	5	4	3	2	1	0
NAME	VIN2 Low Limit Voltage							
DEFAULT	0	0	0	0	0	0	1	0

BIT	DESCRIPTION
7-0	VIN2 Low Limit Voltage. Default: 0x00h

9.85 Reserved Register – Index 9Ch ~ 9Dh (Bank 0)

9.86 3VSB High Limit Voltage Register – Index 9Eh (Bank 0)

Attribute: Read/Write

Size: 8 bits

BIT	7	6	5	4	3	2	1	0
NAME	3VSB High Limit Voltage							
DEFAULT	0	0	0	0	0	0	1	0

BIT	DESCRIPTION
7-0	3VSB High Limit Voltage. Default: 0xFFh



9.87 3VSB Low Limit Voltage Register – Index 9Fh (Bank 0)

Attribute: Read/Write

Size: 8 bits

BIT	7	6	5	4	3	2	1	0
NAME	3VSB Low Limit Voltage							
DEFAULT	0	0	0	0	0	0	1	0

BIT	DESCRIPTION
7-0	3VSB Low Limit Voltage. Default: 0x00h

9.88 VBAT High Limit Voltage Register – Index A0h (Bank 0)

Attribute: Read/Write

Size: 8 bits

BIT	7	6	5	4	3	2	1	0
NAME	VBAT High Limit Voltage							
DEFAULT	0	0	0	0	0	0	1	0

BIT	DESCRIPTION
7-0	VBAT High Limit Voltage. Default: 0xFFh

9.89 VBAT Low Limit Voltage Register – Index A1h (Bank 0)

Attribute: Read/Write

Size: 8 bits

BIT	7	6	5	4	3	2	1	0
NAME	VBAT Low Limit Voltage							
DEFAULT	0	0	0	0	0	0	1	0

BIT	DESCRIPTION
7-0	VBAT Low Limit Voltage. Default: 0x00h

9.90 V10 High Limit Voltage Register – Index A2h (Bank 0)

Attribute: Read/Write

Size: 8 bits

BIT	7	6	5	4	3	2	1	0
NAME	V10 High Limit Voltage							
DEFAULT	0	0	0	0	0	0	1	0

BIT	DESCRIPTION
7-0	V10 High Limit Voltage. Default: 0x00h



7-0	VBAT High Limit Voltage. Default: 0xFFh
-----	--

9.91 V10 Low Limit Voltage Register – Index A3h (Bank 0)

Attribute: Read/Write

Size: 8 bits

BIT	7	6	5	4	3	2	1	0
NAME	V10 Low Limit Voltage							
DEFAULT	0	0	0	0	0	0	1	0

BIT	DESCRIPTION
7-0	V10 Low Limit Voltage. Default: 0x00h

9.92 Reserved Register – Index A4h ~ AFh (Bank 0)

9.93 SMIOVT1 Temperature Source Select Register – Index B0 (Bank 0)

Attribute: Read/Write

Size: 8 bits

BIT	7	6	5	4	3	2	1	0
NAME	RESERVED			SMIOVT_SRC1				
DEFAULT	0	0	0	0	0	0	0	1

BIT	DESCRIPTION
7-5	RESERVED
4-0	<p>SMIOVT1 Temperature selection.</p> <p>Bits</p> <p>4 3 2 1 0</p> <p>0 0 0 0 1: Select SYSTIN as SMIOVT1 monitoring source. (Default)</p> <p>0 0 0 1 0: Select CPUTIN as SMIOVT1 monitoring source.</p> <p>0 0 0 1 1: Select AUXTIN as SMIOVT1 monitoring source.</p> <p>0 0 1 0 0: Select SMBUSMASTER 0 as SMIOVT1 monitoring source.</p> <p>0 0 1 0 1: Select SMBUSMASTER 1 as SMIOVT1 monitoring source.</p> <p>0 0 1 1 0: Select SMBUSMASTER 2 as SMIOVT1 monitoring source.</p> <p>0 0 1 1 1: Select SMBUSMASTER 3 as SMIOVT1 monitoring source.</p> <p>0 1 0 0 0: Select SMBUSMASTER 4 as SMIOVT1 monitoring source.</p> <p>0 1 0 0 1: Select SMBUSMASTER 5 as SMIOVT1 monitoring source.</p> <p>0 1 0 1 0: Select SMBUSMASTER 6 as SMIOVT1 monitoring source.</p> <p>0 1 0 1 1: Select SMBUSMASTER 7 as SMIOVT1 monitoring source.</p> <p>0 1 1 0 0: Select PECI Agent 0 as SMIOVT1 monitoring source.</p> <p>0 1 1 0 1: Select PECI Agent 1 as SMIOVT1 monitoring source.</p> <p>0 1 1 1 0: Select PCH_CHIP_CPU_MAX_TEMP as SMIOVT1 monitoring source.</p> <p>0 1 1 1 1: Select PCH_CHIP_TEMP as SMIOVT1 monitoring source.</p> <p>1 0 0 0 0: Select PCH_CPU_TEMP as SMIOVT1 monitoring source.</p>



1 0 0 0 1:	Select PCH_MCH_TEMP as SMIOVT1 monitoring source.
1 0 0 1 0:	Select PCH_DIM0_TEMP as SMIOVT1 monitoring source.
1 0 0 1 1:	Select PCH_DIM1_TEMP as SMIOVT1 monitoring source.
1 0 1 0 0:	Select PCH_DIM2_TEMP as SMIOVT1 monitoring source.
1 0 1 0 1:	Select PCH_DIM3_TEMP as SMIOVT1 monitoring source.
1 0 1 1 0:	Select BYTE_TEMP as SMIOVT1 monitoring source.

9.94 SMIOVT2 Temperature Source Select Register – Index B1 (Bank 0)

Attribute: Read/Write

Size: 8 bits

BIT	7	6	5	4	3	2	1	0
NAME	RESERVED			SMIOVT_SRC2				
DEFAULT	0	0	0	0	0	0	1	0

BIT	DESCRIPTION
7-5	RESERVED
4-0	<p>SMIOVT2 Temperature selection.</p> <p>Bits</p> <p>4 3 2 1 0</p> <p>0 0 0 0 1: Select SYSTIN as SMIOVT2 monitoring source.</p> <p>0 0 0 1 0: Select CPUTIN as SMIOVT2 monitoring source. (Default)</p> <p>0 0 0 1 1: Select AUXTIN as SMIOVT2 monitoring source.</p> <p>0 0 1 0 0: Select SMBUSMASTER 0 as SMIOVT2 monitoring source.</p> <p>0 0 1 0 1: Select SMBUSMASTER 1 as SMIOVT2 monitoring source.</p> <p>0 0 1 1 0: Select SMBUSMASTER 2 as SMIOVT2 monitoring source.</p> <p>0 0 1 1 1: Select SMBUSMASTER 3 as SMIOVT2 monitoring source.</p> <p>0 1 0 0 0: Select SMBUSMASTER 4 as SMIOVT2 monitoring source.</p> <p>0 1 0 0 1: Select SMBUSMASTER 5 as SMIOVT2 monitoring source.</p> <p>0 1 0 1 0: Select SMBUSMASTER 6 as SMIOVT2 monitoring source.</p> <p>0 1 0 1 1: Select SMBUSMASTER 7 as SMIOVT2 monitoring source.</p> <p>0 1 1 0 0: Select PECI Agent 0 as SMIOVT2 monitoring source.</p> <p>0 1 1 0 1: Select PECI Agent 1 as SMIOVT2 monitoring source.</p> <p>0 1 1 1 0: Select PCH_CHIP_CPU_MAX_TEMP as SMIOVT2 monitoring source.</p> <p>0 1 1 1 1: Select PCH_CHIP_TEMP as SMIOVT2 monitoring source.</p> <p>1 0 0 0 0: Select PCH_CPU_TEMP as SMIOVT2 monitoring source.</p> <p>1 0 0 0 1: Select PCH_MCH_TEMP as SMIOVT2 monitoring source.</p> <p>1 0 0 1 0: Select PCH_DIM0_TEMP as SMIOVT2 monitoring source.</p> <p>1 0 0 1 1: Select PCH_DIM1_TEMP as SMIOVT2 monitoring source.</p> <p>1 0 1 0 0: Select PCH_DIM2_TEMP as SMIOVT2 monitoring source.</p> <p>1 0 1 0 1: Select PCH_DIM3_TEMP as SMIOVT2 monitoring source.</p> <p>1 0 1 1 0: Select BYTE_TEMP as SMIOVT2 monitoring source.</p>

9.95 SMIOVT3 Temperature Source Select Register – Index B2 (Bank 0)

Attribute: Read/Write

Size: 8 bits



BIT	7	6	5	4	3	2	1	0
NAME	RESERVED			SMIOVT_SRC3				
DEFAULT	0	0	0	0	0	0	1	0

BIT	DESCRIPTION
7-5	RESERVED
4-0	<p>SMIOVT3 Temperature selection.</p> <p>Bits</p> <p>4 3 2 1 0</p> <p>0 0 0 0 1: Select SYSTIN as SMIOVT3 monitoring source.</p> <p>0 0 0 1 0: Select CPUTIN as SMIOVT3 monitoring source.</p> <p>0 0 0 1 1: Select AUXTIN as SMIOVT3 monitoring source. (Default)</p> <p>0 0 1 0 0: Select SMBUSMASTER 0 as SMIOVT3 monitoring source.</p> <p>0 0 1 0 1: Select SMBUSMASTER 1 as SMIOVT3 monitoring source.</p> <p>0 0 1 1 0: Select SMBUSMASTER 2 as SMIOVT3 monitoring source.</p> <p>0 0 1 1 1: Select SMBUSMASTER 3 as SMIOVT3 monitoring source.</p> <p>0 1 0 0 0: Select SMBUSMASTER 4 as SMIOVT3 monitoring source.</p> <p>0 1 0 0 1: Select SMBUSMASTER 5 as SMIOVT3 monitoring source.</p> <p>0 1 0 1 0: Select SMBUSMASTER 6 as SMIOVT3 monitoring source.</p> <p>0 1 0 1 1: Select SMBUSMASTER 7 as SMIOVT3 monitoring source.</p> <p>0 1 1 0 0: Select PECI Agent 0 as SMIOVT3 monitoring source.</p> <p>0 1 1 0 1: Select PECI Agent 1 as SMIOVT3 monitoring source.</p> <p>0 1 1 1 0: Select PCH_CHIP_CPU_MAX_TEMP as SMIOVT3 monitoring source.</p> <p>0 1 1 1 1: Select PCH_CHIP_TEMP as SMIOVT3 monitoring source.</p> <p>1 0 0 0 0: Select PCH_CPU_TEMP as SMIOVT3 monitoring source.</p> <p>1 0 0 0 1: Select PCH_MCH_TEMP as SMIOVT3 monitoring source.</p> <p>1 0 0 1 0: Select PCH_DIM0_TEMP as SMIOVT3 monitoring source.</p> <p>1 0 0 1 1: Select PCH_DIM1_TEMP as SMIOVT3 monitoring source.</p> <p>1 0 1 0 0: Select PCH_DIM2_TEMP as SMIOVT3 monitoring source.</p> <p>1 0 1 0 1: Select PCH_DIM3_TEMP as SMIOVT3 monitoring source.</p> <p>1 0 1 1 0: Select BYTE_TEMP as SMIOVT3 monitoring source.</p>

9.96 SMIOVT4 Temperature Source Select Register – Index B3 (Bank 0)

Attribute: Read/Write

Size: 8 bits

BIT	7	6	5	4	3	2	1	0
NAME	RESERVED			SMIOVT_SRC4				
DEFAULT	0	0	0	0	0	0	0	1

BIT	DESCRIPTION
7-5	RESERVED
4-0	<p>SMIOVT4 Temperature selection.</p> <p>Bits</p>



4 3 2 1 0
0 0 0 0 1: Select SYSTIN as SMIOVT4 monitoring source. (Default)
0 0 0 1 0: Select CPUTIN as SMIOVT4 monitoring source.
0 0 0 1 1: Select AUXTIN as SMIOVT4 monitoring source.
0 0 1 0 0: Select SMBUSMASTER 0 as SMIOVT4 monitoring source.
0 0 1 0 1: Select SMBUSMASTER 1 as SMIOVT4 monitoring source.
0 0 1 1 0: Select SMBUSMASTER 2 as SMIOVT4 monitoring source.
0 0 1 1 1: Select SMBUSMASTER 3 as SMIOVT4 monitoring source.
0 1 0 0 0: Select SMBUSMASTER 4 as SMIOVT4 monitoring source.
0 1 0 0 1: Select SMBUSMASTER 5 as SMIOVT4 monitoring source.
0 1 0 1 0: Select SMBUSMASTER 6 as SMIOVT4 monitoring source.
0 1 0 1 1: Select SMBUSMASTER 7 as SMIOVT4 monitoring source.
0 1 1 0 0: Select PECI Agent 0 as SMIOVT4 monitoring source.
0 1 1 0 1: Select PECI Agent 1 as SMIOVT4 monitoring source.
0 1 1 1 0: Select PCH_CHIP_CPU_MAX_TEMP as SMIOVT4 monitoring source.
0 1 1 1 1: Select PCH_CHIP_TEMP as SMIOVT4 monitoring source.
1 0 0 0 0: Select PCH_CPU_TEMP as SMIOVT4 monitoring source.
1 0 0 0 1: Select PCH_MCH_TEMP as SMIOVT4 monitoring source.
1 0 0 1 0: Select PCH_DIM0_TEMP as SMIOVT4 monitoring source.
1 0 0 1 1: Select PCH_DIM1_TEMP as SMIOVT4 monitoring source.
1 0 1 0 0: Select PCH_DIM2_TEMP as SMIOVT4 monitoring source.
1 0 1 0 1: Select PCH_DIM3_TEMP as SMIOVT4 monitoring source.
1 0 1 1 0: Select BYTE_TEMP as SMIOVT4 monitoring source.

9.97 SMIOVT5 Temperature Source Select Register – Index B4 (Bank 0)

Attribute: Read/Write
 Size: 8 bits

BIT	7	6	5	4	3	2	1	0
NAME	RESERVED			SMIOVT_SRC5				
DEFAULT	0	0	0	0	0	0	0	1

BIT	DESCRIPTION
7-5	RESERVED
4-0	SMIOVT5 Temperature selection. Bits 4 3 2 1 0 0 0 0 0 1: Select SYSTIN as SMIOVT5 monitoring source. (Default) 0 0 0 1 0: Select CPUTIN as SMIOVT5 monitoring source. 0 0 0 1 1: Select AUXTIN as SMIOVT5 monitoring source. 0 0 1 0 0: Select SMBUSMASTER 0 as SMIOVT5 monitoring source. 0 0 1 0 1: Select SMBUSMASTER 1 as SMIOVT5 monitoring source. 0 0 1 1 0: Select SMBUSMASTER 2 as SMIOVT5 monitoring source. 0 0 1 1 1: Select SMBUSMASTER 3 as SMIOVT5 monitoring source. 0 1 0 0 0: Select SMBUSMASTER 4 as SMIOVT5 monitoring source. 0 1 0 0 1: Select SMBUSMASTER 5 as SMIOVT5 monitoring source.

0 1 0 1 0:	Select SMBUSMASTER 6 as SMIOVT5 monitoring source.
0 1 0 1 1:	Select SMBUSMASTER 7 as SMIOVT5 monitoring source.
0 1 1 0 0:	Select PECI Agent 0 as SMIOVT5 monitoring source.
0 1 1 0 1:	Select PECI Agent 1 as SMIOVT5 monitoring source.
0 1 1 1 0:	Select PCH_CHIP_CPU_MAX_TEMP as SMIOVT5 monitoring source.
0 1 1 1 1:	Select PCH_CHIP_TEMP as SMIOVT5 monitoring source.
1 0 0 0 0:	Select PCH_CPU_TEMP as SMIOVT5 monitoring source.
1 0 0 0 1:	Select PCH_MCH_TEMP as SMIOVT5 monitoring source.
1 0 0 1 0:	Select PCH_DIM0_TEMP as SMIOVT5 monitoring source.
1 0 0 1 1:	Select PCH_DIM1_TEMP as SMIOVT5 monitoring source.
1 0 1 0 0:	Select PCH_DIM2_TEMP as SMIOVT5 monitoring source.
1 0 1 0 1:	Select PCH_DIM3_TEMP as SMIOVT5 monitoring source.
1 0 1 1 0:	Select BYTE_TEMP as SMIOVT5 monitoring source.

9.98 SMIOVT6 Temperature Source Select Register – Index B5 (Bank 0)

Attribute: Read/Write

Size: 8 bits

BIT	7	6	5	4	3	2	1	0
NAME	RESERVED			SMIOVT_SRC6				
DEFAULT	0	0	0	0	0	0	0	1

BIT	DESCRIPTION
7-5	RESERVED
4-0	SMIOVT6 Temperature selection. Bits 4 3 2 1 0 0 0 0 0 1: Select SYSTIN as SMIOVT6 monitoring source. (Default) 0 0 0 1 0: Select CPUTIN as SMIOVT6 monitoring source. 0 0 0 1 1: Select AUXTIN as SMIOVT6 monitoring source. 0 0 1 0 0: Select SMBUSMASTER 0 as SMIOVT6 monitoring source. 0 0 1 0 1: Select SMBUSMASTER 1 as SMIOVT6 monitoring source. 0 0 1 1 0: Select SMBUSMASTER 2 as SMIOVT6 monitoring source. 0 0 1 1 1: Select SMBUSMASTER 3 as SMIOVT6 monitoring source. 0 1 0 0 0: Select SMBUSMASTER 4 as SMIOVT6 monitoring source. 0 1 0 0 1: Select SMBUSMASTER 5 as SMIOVT6 monitoring source. 0 1 0 1 0: Select SMBUSMASTER 6 as SMIOVT6 monitoring source. 0 1 0 1 1: Select SMBUSMASTER 7 as SMIOVT6 monitoring source. 0 1 1 0 0: Select PECI Agent 0 as SMIOVT6 monitoring source. 0 1 1 0 1: Select PECI Agent 1 as SMIOVT6 monitoring source. 0 1 1 1 0: Select PCH_CHIP_CPU_MAX_TEMP as SMIOVT6 monitoring source. 0 1 1 1 1: Select PCH_CHIP_TEMP as SMIOVT6 monitoring source. 1 0 0 0 0: Select PCH_CPU_TEMP as SMIOVT6 monitoring source. 1 0 0 0 1: Select PCH_MCH_TEMP as SMIOVT6 monitoring source. 1 0 0 1 0: Select PCH_DIM0_TEMP as SMIOVT6 monitoring source. 1 0 0 1 1: Select PCH_DIM1_TEMP as SMIOVT6 monitoring source.



1 0 1 0 0: Select PCH_DIM2_TEMP as SMIOVT6 monitoring source.
1 0 1 0 1: Select PCH_DIM3_TEMP as SMIOVT6 monitoring source.
1 0 1 1 0: Select BYTE_TEMP as SMIOVT6 monitoring source.

9.99 SMI/OVT Control Register – Index B6h (Bank 0)

Attribute: Read/Write

Size: 8 bits

BIT	7	6	5	4	3	2	1	0
NAME	Reserved	Reserved	Reserved	OVTPOL	Reserved	T2ToT6 _INTMODE	EN_T1 _ONE	SMI# ENABLE
DEFAULT	0	0	0	0	0	0	0	1

BIT	DESCRIPTION
7	Reserved
6	Reserved
5	Reserved
4	OVTPOL (Over-temperature polarity). 1: OVT# is active high. 0: OVT# is active low (Default).
3	Reserved
2	T2ToT6_INTMode. 1: SMI# output type of Temperature SMIOVT2, SMIOVT3, SMIOVT4, SMIOVT5 and SMIOVT6 temperature source is in Comparator Interrupt mode. 0: SMI# output type of Temperature SMIOVT2, SMIOVT3, SMIOVT4, SMIOVT5 and SMIOVT6 temperature source is in Two-Times Interrupt mode. (Default)
1	EN_T1_ONE. 1: SMI# output type of SMIOVT Source1 temperature (Default: SYSTIN) is One-Time Interrupt Mode. 0: SMI# output type is in Two-Times Interrupt Mode. (Default)
0	SMI#Enable. A one enables the SMI# Interrupt output.

9.100 SMIOVT1 Control Register – Index B7h (Bank 0)

Attribute: Read/Write

Size: 8 bits

BIT	7	6	5	4	3	2	1	0
NAME	THYST1<0>	TOVF1<0>	FAULT1		DIS_ OVT1	EN_ WS1	OVT1_ Mode	SOPT1
DEFAULT	0	0	0	0	1	0	0	0

BIT	DESCRIPTION
7	THYST1<0> : Hysteresis temperature bit0.



BIT	DESCRIPTION
6	TOVF1<0> : Over-temperature bits0.
5-4	Fault1 . Number of faults to detect before setting OVT# output. This avoids false strapping due to noise.
3	DIS_OVT1 . 0: Enable SMIOVT1 OVT# output. (Default) 1: Disable temperature sensor SMIOVT1 over-temperature (OVT#) output.
2	EN_WS1 . 1: SMI# output type of SMIOVT Source1 temperature (Default: SYSTIN) is Shut-down Interrupt Mode. 0: SMI# output type is in Interrupt Mode. (Default)
1	OVT1_Mode. SMIOVT1 Mode Select . 0: Compare Mode. (Default) 1: Interrupt Mode.
0	STOP1 . 0: Monitor SMIOVT1 temperature source. 1: Stop monitoring SMIOVT1 temperature source.

9.101 SMIOVT2 Control Register – Index B8h (Bank 0)

Attribute: Read/Write

Size: 8 bits

BIT	7	6	5	4	3	2	1	0
NAME	THYST2<0>	TOVF2<0>	FAULT2		DIS_OVT2	EN_WS2	OVT2_Mode	SOPT2
DEFAULT	0	0	0	0	1	0	0	0

BIT	DESCRIPTION
7	THYST2<0> : Hysteresis temperature bit0.
6	TOVF2<0> : Over-temperature bits0.
5-4	Fault2 . Number of faults to detect before setting OVT# output. This avoids false strapping due to noise.
3	DIS_OVT2 . 0: Enable SMIOVT2 OVT# output. (Default) 1: Disable temperature sensor SMIOVT2 over-temperature (OVT#) output.
2	EN_WS2 . 1: SMI# output type of SMIOVT Source2 temperature (Default: CPUTIN) is Shut-down Interrupt Mode. 0: SMI# output type is in Interrupt Mode. (Default)
1	OVT2_Mode. SMIOVT2 Mode Select . 0: Compare Mode. (Default) 1: Interrupt Mode.
0	STOP2 . 0: Monitor SMIOVT2 temperature source. 1: Stop monitoring SMIOVT2 temperature source.



9.102 SMIOVT3 Control Register – Index B9h (Bank 0)

Attribute: Read/Write

Size: 8 bits

BIT	7	6	5	4	3	2	1	0
NAME	THYST3<0>	TOVF3<0>	FAULT3		DIS_OVT3	EN_WS3	OVT3_Mode	SOPT3
DEFAULT	0	0	0	0	1	0	0	0

BIT	DESCRIPTION
7	THYST3<0> : Hysteresis temperature bit0.
6	TOVF3<0> : Over-temperature bits0.
5-4	Fault3 . Number of faults to detect before setting OVT# output. This avoids false strapping due to noise.
3	DIS_OVT3 . 0: Enable SMIOVT3 OVT# output. (Default) 1: Disable temperature sensor SMIOVT3 over-temperature (OVT#) output.
2	EN_WS3 . 1: SMI# output type of SMIOVT Source3 temperature (Default: AUXTIN) is Shut-down Interrupt Mode. 0: SMI# output type is in Interrupt Mode. (Default)
1	OVT3_Mode. SMIOVT3 Mode Select . 0: Compare Mode. (Default) 1: Interrupt Mode.
0	STOP3 . 0: Monitor SMIOVT3 temperature source. 1: Stop monitoring SMIOVT3 temperature source.

9.103 SMIOVT4 Control Register – Index BAh (Bank 0)

Attribute: Read/Write

Size: 8 bits

BIT	7	6	5	4	3	2	1	0
NAME	THYST4<0>	TOVF4<0>	FAULT4		DIS_OVT4	EN_WS4	OVT4_Mode	SOPT4
DEFAULT	0	0	0	0	1	0	0	0

BIT	DESCRIPTION
7	THYST4<0> : Hysteresis temperature bit0.
6	TOVF4<0> : Over-temperature bits0.
5-4	Fault4 . Number of faults to detect before setting OVT# output. This avoids false strapping due to noise.
3	DIS_OVT4 . 0: Enable SMIOVT4 OVT# output. (Default) 1: Disable temperature sensor SMIOVT4 over-temperature (OVT#) output.



BIT	DESCRIPTION
2	EN_WS4. 1: SMI# output type of SMIOVT Source4 temperature (Default: SYSTIN) is Shut-down Interrupt Mode. 0: SMI# output type is in Interrupt Mode. (Default)
1	OVT4_Mode. SMIOVT4 Mode Select. 0: Compare Mode. (Default) 1: Interrupt Mode.
0	STOP4. 0: Monitor SMIOVT4 temperature source. 1: Stop monitoring SMIOVT4 temperature source.

9.104 SMIOVT5 Control Register – Index BBh (Bank 0)

Attribute: Read/Write

Size: 8 bits

BIT	7	6	5	4	3	2	1	0
NAME	THYST5<0>	TOVF5<0>	FAULT5		DIS_OVT5	EN_WS5	OVT5_Mode	SOPT5
DEFAULT	0	0	0	0	1	0	0	0

BIT	DESCRIPTION
7	THYST5<0> : Hysteresis temperature bit0.
6	TOVF5<0> : Over-temperature bits0.
5-4	Fault5. Number of faults to detect before setting OVT# output. This avoids false strapping due to noise.
3	DIS_OVT5. 0: Enable SMIOVT5 OVT# output. (Default) 1: Disable temperature sensor SMIOVT5 over-temperature (OVT#) output.
2	EN_WS5. 1: SMI# output type of SMIOVT Source5 temperature (Default: SYSTIN) is Shut-down Interrupt Mode. 0: SMI# output type is in Interrupt Mode. (Default)
1	OVT5_Mode. SMIOVT5 Mode Select. 0: Compare Mode. (Default) 1: Interrupt Mode.
0	STOP5. 0: Monitor SMIOVT5 temperature source. 1: Stop monitoring SMIOVT5 temperature source.

9.105 SMIOVT6 Control Register – Index BCh (Bank 0)

Attribute: Read/Write

Size: 8 bits

BIT	7	6	5	4	3	2	1	0



NAME	THYST6<0>	TOVF6<0>	FAULT6		DIS_OVT6	EN_WS6	OVT6_Mode	SOPT6
DEFAULT	0	0	0	0	1	0	0	0

BIT	DESCRIPTION
7	THYST6<0> : Hysteresis temperature bit0.
6	TOVF6<0> : Over-temperature bits0.
5-4	Fault6 . Number of faults to detect before setting OVT# output. This avoids false strapping due to noise.
3	DIS_OVT6 . 0: Enable SMIOVT6 OVT# output. (Default) 1: Disable temperature sensor SMIOVT6 over-temperature (OVT#) output.
2	EN_WS6 . 1: SMI# output type of SMIOVT Source6 temperature (Default: SYSTIN) is Shut-down Interrupt Mode. 0: SMI# output type is in Interrupt Mode. (Default)
1	OVT6_Mode. SMIOVT6 Mode Select . 0: Compare Mode. (Default) 1: Interrupt Mode.
0	STOP6 . 0: Monitor SMIOVT6 temperature source. 1: Stop monitoring SMIOVT6 temperature source.

9.106 Reserved Register – Index BDh ~ BFh (Bank 0)

9.107 SMIOVT1 Shut-down mode High Limit Temperature Register – Index C0h (Bank 0)

Attribute: Read/Write

Size: 8 bits

BIT	7	6	5	4	3	2	1	0
NAME	SMIOVT1 Shut-down mode High Limit Temperature							
DEFAULT	0	1	1	1	1	1	1	1

BIT	DESCRIPTION
7-0	SMIOVT1 Shut-down mode High Limit Temperature.

9.108 SMIOVT1 Shut-down mode Low Limit Temperature Register – Index C1h (Bank 0)

Attribute: Read/Write

Size: 8 bits

BIT	7	6	5	4	3	2	1	0
NAME	SMIOVT1 Shut-down mode Low Limit Temperature							
DEFAULT	0	1	1	1	1	1	1	1



BIT	DESCRIPTION
7-0	SMIOVT1 Shut-down mode Low Limit Temperature.

9.109 SMIOVT1 Temperature Source Over-temperature (High Byte) Register – Index C2h (Bank 0)

Attribute: Read/Write

Size: 8 bits

BIT	7	6	5	4	3	2	1	0
NAME	TOVF1<8:1>							
DEFAULT	0	0	0	0	0	0	0	0

BIT	DESCRIPTION
7-0	TOVF1<8:1>. Over-temperature bits 8-1. The nine-bit value is in units of 0.5°C, and the default is 80°C.

9.110 SMIOVT1 Temperature Source Hysteresis (High Byte) Register – Index C3h (Bank 0)

Attribute: Read/Write

Size: 8 bits

BIT	7	6	5	4	3	2	1	0
NAME	THYST1<8:1>							
DEFAULT	0	0	0	0	0	0	0	0

BIT	DESCRIPTION
7-0	THYST1<8:1>. Hysteresis temperature bits 8-1. The nine-bit value is in units of 0.5°C, and the default is 0°C.

9.111 SMIOVT2 Shut-down mode High Limit Temperature Register – Index C4h (Bank 0)

Attribute: Read/Write

Size: 8 bits

BIT	7	6	5	4	3	2	1	0
NAME	SMIOVT2 Shut-down mode High Limit Temperature							
DEFAULT	0	1	1	1	1	1	1	1

BIT	DESCRIPTION
7-0	SMIOVT2 Shut-down mode High Limit Temperature.

9.112 SMIOVT2 Shut-down mode Low Limit Temperature Register – Index C5h (Bank 0)

Attribute: Read/Write

Size: 8 bits



BIT	7	6	5	4	3	2	1	0
NAME	SMIOVT2 Shut-down mode Low Limit Temperature							
DEFAULT	0	1	1	1	1	1	1	1

BIT	DESCRIPTION
7-0	SMIOVT2 Shut-down mode Low Limit Temperature.

9.113 SMIOVT2 Temperature Source Over-temperature (High Byte) Register – Index C6h (Bank 0)

Attribute: Read/Write

Size: 8 bits

BIT	7	6	5	4	3	2	1	0
NAME	TOVF2<8:1>							
DEFAULT	0	1	0	1	0	0	0	0

BIT	DESCRIPTION
7-0	TOVF2<8:1>. Over-temperature bits 8-1. The nine-bit value is in units of 0.5°C, and the default is 80°C.

9.114 SMIOVT2 Temperature Source Hysteresis (High Byte) Register – Index C7h (Bank 0)

Attribute: Read/Write

Size: 8 bits

BIT	7	6	5	4	3	2	1	0
NAME	THYST2<8:1>							
DEFAULT	0	1	0	0	1	0	1	1

BIT	DESCRIPTION
7-0	THYST2<8:1>. Hysteresis temperature bits 8-1. The nine-bit value is in units of 0.5°C, and the default is 75°C.

9.115 SMIOVT3 Shut-down mode High Limit Temperature Register – Index C8h (Bank 0)

Attribute: Read/Write

Size: 8 bits

BIT	7	6	5	4	3	2	1	0
NAME	SMIOVT3 Shut-down mode High Limit Temperature							
DEFAULT	0	1	1	1	1	1	1	1

BIT	DESCRIPTION
7-0	SMIOVT3 Shut-down mode High Limit Temperature.



9.116 SMIOVT3 Shut-down mode Low Limit Temperature Register – Index C9h (Bank 0)

Attribute: Read/Write

Size: 8 bits

BIT	7	6	5	4	3	2	1	0
NAME	SMIOVT3 Shut-down mode Low Limit Temperature							
DEFAULT	0	1	1	1	1	1	1	1

BIT	DESCRIPTION
7-0	SMIOVT3 Shut-down mode Low Limit Temperature.

9.117 SMIOVT3 Temperature Source Over-temperature (High Byte) Register – Index CAh (Bank 0)

Attribute: Read/Write

Size: 8 bits

BIT	7	6	5	4	3	2	1	0
NAME	TOVF3<8:1>							
DEFAULT	0	1	0	1	0	0	0	0

BIT	DESCRIPTION
7-0	TOVF3<8:1>. Over-temperature bits 8-1. The nine-bit value is in units of 0.5°C, and the default is 80°C.

9.118 SMIOVT3 Temperature Source Hysteresis (High Byte) Register – Index CBh (Bank 0)

Attribute: Read/Write

Size: 8 bits

BIT	7	6	5	4	3	2	1	0
NAME	THYST3<8:1>							
DEFAULT	0	1	0	0	1	0	1	1

BIT	DESCRIPTION
7-0	THYST3<8:1>. Hysteresis temperature bits 8-1. The nine-bit value is in units of 0.5°C, and the default is 75°C.

9.119 SMIOVT4 Shut-down mode High Limit Temperature Register – Index CCh (Bank 0)

Attribute: Read/Write

Size: 8 bits

BIT	7	6	5	4	3	2	1	0
NAME	SMIOVT4 Shut-down mode High Limit Temperature							
DEFAULT	0	1	1	1	1	1	1	1



BIT	DESCRIPTION
7-0	SMIOVT4 Shut-down mode High Limit Temperature.

9.120 SMIOVT4 Shut-down mode Low Limit Temperature Register – Index CDh (Bank 0)

Attribute: Read/Write

Size: 8 bits

BIT	7	6	5	4	3	2	1	0
NAME	SMIOVT4 Shut-down mode Low Limit Temperature							
DEFAULT	0	1	1	1	1	1	1	1

BIT	DESCRIPTION
7-0	SMIOVT4 Shut-down mode Low Limit Temperature.

9.121 SMIOVT4 Temperature Source Over-temperature (High Byte) Register – Index CEh (Bank 0)

Attribute: Read/Write

Size: 8 bits

BIT	7	6	5	4	3	2	1	0
NAME	TOVF4<8:1>							
DEFAULT	0	1	0	1	0	0	0	0

BIT	DESCRIPTION
7-0	TOVF4<8:1>. Over-temperature bits 8-1. The nine-bit value is in units of 0.5°C, and the default is 80°C.

9.122 SMIOVT4 Temperature Source Hysteresis (High Byte) Register – Index CFh (Bank 0)

Attribute: Read/Write

Size: 8 bits

BIT	7	6	5	4	3	2	1	0
NAME	THYST4<8:1>							
DEFAULT	0	1	0	0	1	0	1	1

BIT	DESCRIPTION
7-0	THYST4<8:1>. Hysteresis temperature bits 8-1. The nine-bit value is in units of 0.5°C, and the default is 75°C.

9.123 SMIOVT5 Shut-down mode High Limit Temperature Register – Index D0h (Bank 0)

Attribute: Read/Write



Size: 8 bits

BIT	7	6	5	4	3	2	1	0
NAME	SMIOVT5 Shut-down mode High Limit Temperature							
DEFAULT	0	1	1	1	1	1	1	1

BIT	DESCRIPTION
7-0	SMIOVT5 Shut-down mode High Limit Temperature.

9.124 SMIOVT5 Shut-down mode Low Limit Temperature Register – Index D1h (Bank 0)

Attribute: Read/Write

Size: 8 bits

BIT	7	6	5	4	3	2	1	0
NAME	SMIOVT5 Shut-down mode Low Limit Temperature							
DEFAULT	0	1	1	1	1	1	1	1

BIT	DESCRIPTION
7-0	SMIOVT5 Shut-down mode Low Limit Temperature.

9.125 SMIOVT5 Temperature Source Over-temperature (High Byte) Register – Index D2h (Bank 0)

Attribute: Read/Write

Size: 8 bits

BIT	7	6	5	4	3	2	1	0
NAME	TOVF5<8:1>							
DEFAULT	0	1	0	1	0	0	0	0

BIT	DESCRIPTION
7-0	TOVF5<8:1>. Over-temperature bits 8-1. The nine-bit value is in units of 0.5°C, and the default is 80°C.

9.126 SMIOVT5 Temperature Source Hysteresis (High Byte) Register – Index D3h (Bank 0)

Attribute: Read/Write

Size: 8 bits

BIT	7	6	5	4	3	2	1	0
NAME	THYST5<8:1>							
DEFAULT	0	1	0	0	1	0	1	1

BIT	DESCRIPTION
-----	-------------



BIT	DESCRIPTION
7-0	THYST5<8:1> . Hysteresis temperature bits 8-1. The nine-bit value is in units of 0.5°C, and the default is 75°C.

9.127 SMIOVT6 Shut-down mode High Limit Temperature Register – Index D4h (Bank 0)

Attribute: Read/Write

Size: 8 bits

BIT	7	6	5	4	3	2	1	0
NAME	SMIOVT6 Shut-down mode High Limit Temperature							
DEFAULT	0	1	1	1	1	1	1	1

BIT	DESCRIPTION
7-0	SMIOVT6 Shut-down mode High Limit Temperature.

9.128 SMIOVT6 Shut-down mode Low Limit Temperature Register – Index D5h (Bank 0)

Attribute: Read/Write

Size: 8 bits

BIT	7	6	5	4	3	2	1	0
NAME	SMIOVT6 Shut-down mode Low Limit Temperature							
DEFAULT	0	1	1	1	1	1	1	1

BIT	DESCRIPTION
7-0	SMIOVT6 Shut-down mode Low Limit Temperature.

9.129 SMIOVT6 Temperature Source Over-temperature (High Byte) Register – Index D6h (Bank 0)

Attribute: Read/Write

Size: 8 bits

BIT	7	6	5	4	3	2	1	0
NAME	TOVF6<8:1>							
DEFAULT	0	1	0	1	0	0	0	0

BIT	DESCRIPTION
7-0	TOVF6<8:1> . Over-temperature bits 8-1. The nine-bit value is in units of 0.5°C, and the default is 80°C.

9.130 SMIOVT6 Temperature Source Hysteresis (High Byte) Register – Index D7h (Bank 0)

Attribute: Read/Write

Size: 8 bits



BIT	7	6	5	4	3	2	1	0
NAME	THYST6<8:1>							
DEFAULT	0	1	0	0	1	0	1	1

BIT	DESCRIPTION
7-0	THYST6<8:1> . Hysteresis temperature bits 8-1. The nine-bit value is in units of 0.5°C, and the default is 75°C.

9.131 Reserved Register – Index D8h ~ DFh (Bank 0)

9.132 (SYSFANIN) Fan Count Limit High-byte Register – Index E0h (Bank 0)

Attribute: Read

Size: 8 bits

BIT	7	6	5	4	3	2	1	0
NAME	FANIN1_HL [12:5]							
DEFAULT	0	0	0	0	0	0	0	0

BIT	DESCRIPTION
7-0	FANIN1_HL : 13-bit SYSFANIN Fan Count Limit, High Byte

9.133 (SYSFANIN) Fan Count Limit Low-byte Register – Index E1h (Bank 0)

Attribute: Read

Size: 8 bits

BIT	7	6	5	4	3	2	1	0
NAME	RESERVED			FANIN1_HL [4:0]				
DEFAULT	0			0				

BIT	DESCRIPTION
7-5	Reserved.
4-0	FANIN1_HL : 13-bit SYSFANIN Fan Count Limit, Low Byte

9.134 (CPUFANIN) Fan Count Limit High-byte Register – Index E2h (Bank 0)

Attribute: Read

Size: 8 bits

BIT	7	6	5	4	3	2	1	0
NAME	FANIN2_HL [12:5]							
DEFAULT	0	0	0	0	0	0	0	0



BIT	DESCRIPTION
7-0	FANIN2_HL: 13-bit CPUFANIN Fan Count Limit, High Byte

9.135 (CPUFANIN) Fan Count Limit Low-byte Register – Index E3h (Bank 0)

Attribute: Read

Size: 8 bits

BIT	7	6	5	4	3	2	1	0
NAME	RESERVED				FANIN2_HL [4:0]			
DEFAULT	0				0			

BIT	DESCRIPTION
7-5	Reserved.
4-0	FANIN2_HL: 13-bit CPUFANIN Fan Count Limit, Low Byte

9.136 (AUXFANIN) Fan Count Limit High-byte Register – Index E4h (Bank 0)

Attribute: Read

Size: 8 bits

BIT	7	6	5	4	3	2	1	0
NAME	FANIN3_HL [12:5]							
DEFAULT	0	0	0	0	0	0	0	0

BIT	DESCRIPTION
7-0	FANIN3_HL: 13-bit AUXFANIN Fan Count Limit, High Byte

9.137 (AUXFANIN) Fan Count Limit Low-byte Register – Index E5h (Bank 0)

Attribute: Read

Size: 8 bits

BIT	7	6	5	4	3	2	1	0
NAME	RESERVED				FANIN3_HL [4:0]			
DEFAULT	0				0			

BIT	DESCRIPTION
7-5	Reserved.
4-0	FANIN3_HL: 13-bit AUXFANIN Fan Count Limit, Low Byte

9.138 Reserved Register – Index E6h ~ EFh (Bank 0)

9.139 SYSFAN PWM Output Frequency Configuration Register – Index F0h (Bank 0)



Attribute: Read/Write

Size: 8 bits

BIT	7	6	5	4	3	2	1	0
NAME	PWM_CLK_SEL1	PWM_SCALE1						
DEFAULT	0	3						

The register is meaningful only when SYSFANOUT is programmed for PWM output (i.e., Bank0, Index F3h, bit 0 is 0).

BIT	DESCRIPTION
7	PWM_CLK_SEL1. SYSFANOUT PWM Input Clock Source Select. This bit selects the clock source for PWM output frequency. Refer the Divisor table.
6-0	PWM_SCALE1. SYSFANOUT PWM Pre-Scale divider. The clock source for PWM output is divided by this seven-bit value to calculate the actual PWM output frequency. Refer the Divisor table.

9.140 CPUFAN PWM Output Frequency Configuration Register – Index F1h (Bank 0)

Attribute: Read/Write

Size: 8 bits

BIT	7	6	5	4	3	2	1	0
NAME	PWM_CLK_SEL2	PWM_SCALE2						
DEFAULT	0	3						

The register is meaningful only when CPUFANOUT is programmed for PWM output (i.e., Bank0, Index F3h, bit 1 is 0).

BIT	DESCRIPTION
7	PWM_CLK_SEL2. CPUFANOUT PWM Input Clock Source Select. This bit selects the clock source for the PWM output. Refer the Divisor table.
6-0	PWM_SCALE2. CPUFANOUT PWM Pre-Scale divider. The clock source for PWM output is divided by this seven-bit value to calculate the actual PWM output frequency. Refer the Divisor table.

9.141 AUXFAN PWM Output Frequency Configuration Register – Index F2h (Bank 0)

Attribute: Read/Write

Size: 8 bits

BIT	7	6	5	4	3	2	1	0
NAME	PWM_CLK_SEL3	PWM_SCALE3						
DEFAULT	0	3						

This register is only meaningful when AUXFANOUT is programmed for PWM output (i.e. Bank0, Index F3h, bit 2 is 0)



BIT	DESCRIPTION
7	PWM_CLK_SEL3. AUXFANOUT PWM Input Clock Source Select. This bit selects the clock source of PWM output frequency. Refer the Divisor table.
6-0	PWM_CLK_SCALE3. AUXFANOUT PWM Pre-Scale divider. The clock source for PWM output is divided by this seven-bit value to calculate the actual PWM output frequency. Refer the Divisor table.

The clock source selected by CKSEL will be divided by the divisor and used as a fan PWM output frequency.

If CKSEL equals **0**, then the output clock is simply equal to **92.5/ (Divisor[6:0]+1) KHz**

MappedDivisor depends on **Divisor[6:0]** and is described in the table below.

Divisor[6:0]	Mapped Divisor	Output Frequency	Divisor[6:0]	Mapped Divisor	Output Frequency
0000000	1	92.5KHz		
0000001	2	46.3KHz			
0000010	3	31.2KHz			
0000011	4	23.3KHz			
0000100	5	18.5KHz	0001111	16	5.8KHz
0000101	6	15.6KHz	0011111	32	2.9KHz
0000110	7	13.3KHz	0111111	64	1.4KHz
0000111	8	11.6KHz	1111111	128	724Hz

If CKSEL equals **1**, then the output clock is simply equal to **1008/ Mapped Divisor Hz**

MappedDivisor depends on **Divisor[3:0]** and is described in the table below.

Divisor[3:0]	Mapped Divisor	Output Frequency	Divisor[3:0]	Mapped Divisor	Output Frequency
0000	1	1000Hz	1000	12	83Hz
0001	2	500Hz	1001	16	62.5Hz
0010	3	333Hz	1010	32	31.25Hz
0011	4	250Hz	1011	64	15.62Hz
0100	5	200Hz	1100	128	7.81Hz
0101	6	166Hz	1101	256	3.9Hz
0110	7	142Hz	1110	512	2Hz
0111	8	125Hz	1111	1024	0.98Hz

9.142 FAN Output Mode Configuration – Index F3h (Bank 0)

Attribute: Read/Write

Size: 8 bits

BIT	7	6	5	4	3	2	1	0
NAME	RESERVED					AUXFANOUT_SEL	CPUFANOUT_SEL	SYSFANOUT_SEL
DEFAULT	0					0	0	0

BIT	DESCRIPTION
7-3	Reserved.



BIT	DESCRIPTION
2	AUXFANOUT Output Mode Selection. 0: AUXFANAOUT pin produces a PWM output duty cycle. (Default) 1: AUXFANOUT pin produces DC output.
1	CPUFANOUT Output Mode Selection. 0: CPUFANOUT pin produces a PWM output duty cycle. (Default) 1: CPUFANOUT pin produces DC output.
0	SYSFANOUT Output Mode Selection. 0: SYSFANOUT pin produces a PWM duty cycle output. (Default) 1: SYSFANOUT pin produces DC output.

9.143 Reserved Register – Index F4h ~ F5h (Bank 0)

9.144 FANIN Revolution Pulses Selection Register – Index F6h (Bank 0)

Attribute: Read/Write

Size: 8 bits

BIT	7	6	5	4	3	2	1	0
NAME	Reserved		HM_Rev_Pulse_Fan3_Sel		HM_Rev_Pulse_Fan2_Sel		HM_Rev_Pulse_Fan1_Sel	
DEFAULT	0		0		0		0	

BIT	DESCRIPTION
7-6	Reserved
5-4	AUXFANIN Revolution Pulses Selection = 00, four pulses per revolution. = 01, one pulse per revolution. = 10, two pulses per revolution. (default) = 11, three pulses per revolution.
3-2	CPUFANIN Revolution Pulses Selection = 00, four pulses per revolution. = 01, one pulse per revolution. = 10, two pulses per revolution. (default) = 11, three pulses per revolution.
1-0	SYSFANIN Revolution Pulses Selection = 00, four pulses per revolution. = 01, one pulse per revolution. = 10, two pulses per revolution. (default) = 11, three pulses per revolution.

9.145 Serial Bus Address Register – Index F7h (Bank 0)

Attribute: Read/Write

Size: 8 bits

BIT	7	6	5	4	3	2	1	0



NAME	RESERVED	SERIAL BUS ADDRESS						
DEFAULT	0	0	1	0	1	1	0	1

BIT	DESCRIPTION
7	Reserved (Read Only).
6-0	Serial Bus Address <7:1>

9.146 FAN IN/OUT Control Register – Index F8h (Bank 0)

Attribute: Read/Write

Size: 8 bits

BIT	7	6	5	4	3	2	1	0
NAME	RESERVED				FANOPV2	FANINC2	FANOPV1	FANINC1
DEFAULT	0	0	0	0	0	1	0	1

BIT	DESCRIPTION
7-4	Reserved.
3	FANOPV2. CPUFANIN output value , only if bit 2 is set to zero. 1: Pin 124 (CPUFANIN) generates a logic-high signal. 0: Pin 124 generates a logic-low signal. (Default)
2	FANINC2. CPUFANIN Input Control . 1: Pin 124 (CPUFANIN) acts as a fan tachometer input. (Default) 0: Pin 124 acts as a fan control signal, and the output value is set by bit 3.
1	FANOPV1. SYSFANIN output value , only if bit 0 is set to zero. 1: Pin 126 (SYSFANIN) generates a logic-high signal. 0: Pin 126 generates a logic-low signal. (Default)
0	FANINC1. SYSFANIN Input Control . 1: Pin 126 (SYSFANIN) acts as a fan tachometer input. (Default) 0: Pin 126 acts as a fan control signal, and the output value is set by bit 1.

9.147 Reserved Register – Index F9h ~ FCh (Bank 0)

9.148 Nuvoton Vendor ID Register by I2C Interface – Index FDh (Bank 0)

Attribute: Read Only

Size: 16 bits

BIT	15	14	13	12	11	10	9	8	
NAME	VIDH								
DEFAULT	0	1	0	1	1	1	0	0	

BIT	7	6	5	4	3	2	1	0	
NAME	VIDL								



DEFAULT	1	0	1	0	0	0	1	1
---------	---	---	---	---	---	---	---	---

BIT	DESCRIPTION
15-8	Vendor ID High-Byte, if Index 4Eh, bit 7 is 1. Default 5Ch.
7-0	Vendor ID Low-Byte, if Index 4Eh, bit 7 is 0. Default A3h.

9.149 Nuvoton Vendor ID Register by LPC Interface – Index FEh (Bank 0)

Attribute: Read Only

Size: 16 bits

BIT	15	14	13	12	11	10	9	8
NAME	VIDH							
DEFAULT	0	1	0	1	1	1	0	0

BIT	7	6	5	4	3	2	1	0
NAME	VIDL							
DEFAULT	1	0	1	0	0	0	1	1

BIT	DESCRIPTION
15-8	Vendor ID High-Byte, if Index 4Eh, bit 7 is 1. Default 5Ch.
7-0	Vendor ID Low-Byte, if Index 4Eh, bit 7 is 0. Default A3h.

9.150 Chip ID – Index FFh (Bank 0)

Attribute: Read Only

Size: 8 bits

BIT	7	6	5	4	3	2	1	0
NAME	CHIPID							
DEFAULT	1	1	0	0	0	0	0	1

BIT	DESCRIPTION
7-0	Nuvoton Chip ID number. Default C1h.

9.151 SYSFAN Monitor Temperature Source Select Register/ STOPDUTY Enable Register – Index 10h (Bank 1)

Attribute: Read/Write

Size: 8 bits

BIT	7	6	5	4	3	2	1	0
NAME	Stopduty_En	Reserved			SYSFAN SOURCE[4:0]			
DEFAULT	0	0			1			



BIT	DESCRIPTION
7	Stopduty_En: 0: FANOUT will decrease to zero value at most if necessary. 1: FANOUT will decrease to SYSFANOUT Stop Value (Bank1, index16h) at most if necessary.
6-5	Reserved
4-0	SYSFAN Temperature Source Select: Bits 4 3 2 1 0 0 0 0 0 1: Select SYSTIN as SYSFAN monitoring source. (Default) 0 0 0 1 0: Select CPUTIN as SYSFAN monitoring source. 0 0 0 1 1: Select AUXTIN as SYSFAN monitoring source. 0 0 1 0 0: Select SMBUSMASTER 0 as SYSFAN monitoring source. 0 0 1 0 1: Select SMBUSMASTER 1 as SYSFAN monitoring source. 0 0 1 1 0: Select SMBUSMASTER 2 as SYSFAN monitoring source. 0 0 1 1 1: Select SMBUSMASTER 3 as SYSFAN monitoring source. 0 1 0 0 0: Select SMBUSMASTER 4 as SYSFAN monitoring source. 0 1 0 0 1: Select SMBUSMASTER 5 as SYSFAN monitoring source. 0 1 0 1 0: Select SMBUSMASTER 6 as SYSFAN monitoring source. 0 1 0 1 1: Select SMBUSMASTER 7 as SYSFAN monitoring source. 0 1 1 0 0: Select PECI Agent 0 as SYSFAN monitoring source. 0 1 1 0 1: Select PECI Agent 1 as SYSFAN monitoring source. 0 1 1 1 0: Select PCH_CHIP_CPU_MAX_TEMP as SYSFAN monitoring source. 0 1 1 1 1: Select PCH_CHIP_TEMP as SYSFAN monitoring source. 1 0 0 0 0: Select PCH_CPU_TEMP as SYSFAN monitoring source. 1 0 0 0 1: Select PCH_MCH_TEMP as SYSFAN monitoring source. 1 0 0 1 0: Select PCH_DIM0_TEMP as SYSFAN monitoring source. 1 0 0 1 1: Select PCH_DIM1_TEMP as SYSFAN monitoring source. 1 0 1 0 0: Select PCH_DIM2_TEMP as SYSFAN monitoring source. 1 0 1 0 1: Select PCH_DIM3_TEMP as SYSFAN monitoring source. 1 0 1 1 0: Select BYTE_TEMP as SYSFAN monitoring source.

9.152 SYSFAN Target Temperature Register / SYSFANIN Target Speed_L Register – Index 11h (Bank 1)

Attribute: Read/Write
Size: 8 bits

BIT	7	6	5	4	3	2	1	0
NAME	SYSTIN Target Temperature / SYSFANIN Target Speed_L							
DEFAULT	0							

FUNCTION MODE		7	6	5	4	3	2	1	0
Thermal Cruise™	DESCRIPTION	SYSFAN Target Temperature							
Fan Speed Cruise™	DESCRIPTION	SYSFANIN Target Speed [7:0], [11:8] associate index 12 [3:0]							



9.153 SYSFANIN Tolerance_H / Target Speed_H Register – Index 12h (Bank 1)

Attribute: Read/Write

Size: 8 bits

BIT	7	6	5	4	3	2	1	0
NAME	Reserved	SYSFANIN TOL_H			SYSFANIN Target Speed_H			
DEFAULT	0	0			0			

BIT	DESCRIPTION
7	Reserved
6-4	SYSFANIN Tolerance_H [5:3]
3-0	SYSFANIN Target Speed_H [11:8]

9.154 SYSFAN MODE Register / SYSFAN TOLERRANCE Register – Index 13h (Bank 1)

Attribute: Read/Write

Size: 8 bits

BIT	7	6	5	4	3	2	1	0
NAME	SYSFAN MODE				Reserved	Tolerance of SYSFAN Target Temperature or SYSFANIN Target Speed_L		
DEFAULT	0				0	0		

BIT	DESCRIPTION
7-4	SYSFANOUT Mode Select. 0000: SYSFANOUT is in Manual Mode. (Default) 0001: SYSFANOUT is in Thermal Cruise Mode. 0010: SYSFANOUT is in Speed Cruise Mode. 0100: SYSFANOUT is in SMART FAN™ IV Mode.
3	Reserved
2-0	Tolerance of SYSFAN Target Temperature or SYSFANIN Target Speed_L.

9.155 SYSFAN Step Up Time Register – Index 14h (Bank 1)

Attribute: Read/Write

Size: 8 bits

BIT	7	6	5	4	3	2	1	0
NAME	SYSFANOUT Step Up Time Value							
DEFAULT	A							

In SMART FAN™ mode, this register determines the amount of time SYSFANOUT takes to increase its value by one step.

(1) For PWM output:



The units are intervals of 0.1 second. The default time is 1 second.

9.156 SYSFAN Step Down Time Register – Index 15h (Bank 1)

Attribute: Read/Write

Size: 8 bits

BIT	7	6	5	4	3	2	1	0
NAME	SYSFANOUT Step Down Time Value							
DEFAULT	A							

In SMART FAN™ mode, this register determines the amount of time SYSFANOUT takes to decrease its value by one step.

(1) For PWM output:

The units are intervals of 0.1 second. The default time is 1 second.

9.157 SYSFAN Stop Value Register – Index 16h (Bank 1)

Attribute: Read/Write

Size: 8 bits

BIT	7	6	5	4	3	2	1	0
NAME	SYSFANOUT Stop Value							
DEFAULT	1							

In Thermal Cruise mode, the SYSFANOUT value decreases to this eight-bit value if the temperature stays below the lowest temperature limit. This value should not be zero.

Please note that Stop Value does not mean that the fan really stops. It means that if the temperature keeps below low temperature limit, then the fan speed keeps on decreasing until reaching a minimum value, and this is Stop Value.

9.158 SYSFAN Start-up Value Register – Index 17h (Bank 1)

Attribute: Read/Write

Size: 8 bits

BIT	7	6	5	4	3	2	1	0
NAME	SYSFANOUT Start-Up Value							
DEFAULT	1							

In Thermal Cruise mode, SYSFANOUT value increases from zero to this eight-bit register value to provide a minimum value to turn on the fan.

9.159 SYSFAN Stop Time Register – Index 18h (Bank 1)

Attribute: Read/Write

Size: 8 bits

BIT	7	6	5	4	3	2	1	0
NAME	SYSFANOUT Stop Time							



DEFAULT	3C
---------	----

In Thermal Cruise mode, Define the retention time to the fan stop. It is required by Fan Stop Function.
The time unit is 0.1sec.

9.160 SYSFAN Output Value Select Register – Index 19h (Bank 1)

Attribute: Read/Write

Size: 8 bits

BIT	7	6	5	4	3	2	1	0
NAME	SYSFANOUT Value							
DEFAULT	7F							

FUNCTION MODE		7	6	5	4	3	2	1	0
PWM Output (Bank0, Index F3h, bit 0 is 0)	DESCRIPTION	The PWM duty cycle is equal to this eight-bit value, divided by 255, times 100%. FFh creates a duty cycle of 100%, and 00h creates a duty cycle of 0%.							
DC Voltage Output Bank0, Index F3h, bit 0 is 1)	DESCRIPTION	SYSFANOUT voltage control. The output voltage is calculated according to this equation. $\text{OUTPUT Voltage} = V_{ref} * \frac{FANOUT}{64}$						Reserved	
		Note. VREF is approx 2.048V.							

9.161 SYSFAN Temperature Critical Register – Index 1Ah (Bank 1)

Attribute: Read/Write

Size: 8 bits

BIT	7	6	5	4	3	2	1	0
NAME	SYSFAN Temperature Critical							
DEFAULT	3C							

BIT	DESCRIPTION
7-0	SYSFAN Temperature Critical Register.

9.162 SYSFAN Critical Temperature Tolerance Register – Index 1Bh (Bank 1)

Attribute: Read/Write

Size: 8 bits

BIT	7	6	5	4	3	2	1	0
NAME	Reserved				SYSFANOUT Critical Temperature Tolerance			
DEFAULT	0				0			



BIT	DESCRIPTION
7-3	Reserved
2-0	SYSFAN Critical Temperature Tolerance

9.163 SYSFAN Enable Critical Duty / Fanout Step Register – Index 1Ch (Bank 1)

Attribute: Read/Write

Size: 8 bits

BIT	7	6	5	4	3	2	1	0
NAME	En_SYS_3WFAN	Reserved		En_SYS_CRITICAL_DUTY	Reserved			En_SYSFANOUT_STEP
DEFAULT	0	0		0	0			0

BIT	DESCRIPTION
7	En_SYS_3WFAN 0: 4-wire fan 1: 3-wire fan
6-5	Reserved
4	En_SYS_CRITICAL_DUTY 0: Load default Full Speed 8'hFF for SYSFANOUT. 1: Used Index 1D CRITICAL_DUTY Value for SYSFANOUT.
3-1	Reserved
0	En_SYSFANOUT_STEP 0: Disable SMART FAN™ IV has Stepping SYSFANOUT. 1: Enable SMART FAN™ IV has Stepping SYSFANOUT.

9.164 SYSFAN Critical Duty Register – Index 1Dh (Bank 1)

Attribute: Read/Write

Size: 8 bits

BIT	7	6	5	4	3	2	1	0
NAME	SYSFAN Critical Duty							
DEFAULT	CC							

BIT	DESCRIPTION
7-0	SYSFAN Critical Duty.

9.165 SYSFAN Enable Close Loop Fan Control RPM Mode Register – Index 1Eh (Bank 1)

Attribute: Read/Write

Size: 8 bits

BIT	7	6	5	4	3	2	1	0
NAME	Reserved							En_SYS_RPM



DEFAULT	0	0
---------	---	---

BIT	DESCRIPTION
7-1	Reserved
0	En_SYS_RPM 0: Disable SMART FAN™ IV Close Loop Fan Control RPM Mode. 1: Enable SMART FAN™ IV Close Loop Fan Control RPM Mode.

9.166 SYSFAN Enable RPM High Mode / RPM Mode Tolerance Register – Index 1Fh (Bank 1)

Attribute: Read/Write

Size: 8 bits

BIT	7	6	5	4	3	2	1	0
NAME	En_SYS_RPM_High	Reserved			Generic_Tol_RPM			
DEFAULT	0	0			2			

BIT	DESCRIPTION
7	En_SYS_RPM_High For High Speed Fan Control at RPM Mode, the unit is 100 RPM. Support 100 rpm ~ 25500 rpm Fan, 0: Disable 1: Enable
6-4	Reserved
3-0	Tolerance of RPM mode, unit 50 RPM. If Enable RPM High Mode, unit is 100 RPM.

9.167 CPUFAN Monitor Temperature Source Select Register/ STOPDUTY Enable Register – Index 20h (Bank 1)

Attribute: Read/Write

Size: 8 bits

BIT	7	6	5	4	3	2	1	0
NAME	Stopduty_En	Reserved			CPUFAN SOURCE[4:0]			
DEFAULT	0	0			2			

BIT	DESCRIPTION
7	Stopduty_En: 0: FANOUT will decrease to zero value at most if necessary. 1: FANOUT will decrease to CPUFANOUT Stop Value (Bank1, index26h) at most if necessary.
6-5	Reserved
4-0	CPUFAN Temperature Source Select:



BIT	DESCRIPTION
	Bits
	4 3 2 1 0
	0 0 0 0 1: Select SYSTIN as CPUFAN monitoring source.
	0 0 0 1 0: Select CPUTIN as CPUFAN monitoring source. (Default)
	0 0 0 1 1: Select AUXTIN as CPUFAN monitoring source.
	0 0 1 0 0: Select SMBUSMASTER 0 as CPUFAN monitoring source.
	0 0 1 0 1: Select SMBUSMASTER 1 as CPUFAN monitoring source.
	0 0 1 1 0: Select SMBUSMASTER 2 as CPUFAN monitoring source.
	0 0 1 1 1: Select SMBUSMASTER 3 as CPUFAN monitoring source.
	0 1 0 0 0: Select SMBUSMASTER 4 as CPUFAN monitoring source.
	0 1 0 0 1: Select SMBUSMASTER 5 as CPUFAN monitoring source.
	0 1 0 1 0: Select SMBUSMASTER 6 as CPUFAN monitoring source.
	0 1 0 1 1: Select SMBUSMASTER 7 as CPUFAN monitoring source.
	0 1 1 0 0: Select PECI Agent 0 as CPUFAN monitoring source.
	0 1 1 0 1: Select PECI Agent 1 as CPUFAN monitoring source.
	0 1 1 1 0: Select PCH_CHIP_CPU_MAX_TEMP as CPUFAN monitoring source.
	0 1 1 1 1: Select PCH_CHIP_TEMP as CPUFAN monitoring source.
	1 0 0 0 0: Select PCH_CPU_TEMP as CPUFAN monitoring source.
	1 0 0 0 1: Select PCH_MCH_TEMP as CPUFAN monitoring source.
	1 0 0 1 0: Select PCH_DIM0_TEMP as CPUFAN monitoring source.
	1 0 0 1 1: Select PCH_DIM1_TEMP as CPUFAN monitoring source.
	1 0 1 0 0: Select PCH_DIM2_TEMP as CPUFAN monitoring source.
	1 0 1 0 1: Select PCH_DIM3_TEMP as CPUFAN monitoring source.
	1 0 1 1 0: Select BYTE_TEMP as CPUFAN monitoring source.

9.168 CPUFAN Target Temperature Register / CPUFANIN Target Speed_L Register – Index 21h (Bank 1)

Attribute: Read/Write

Size: 8 bits

BIT	7	6	5	4	3	2	1	0
NAME	CPUFANIN Target Temperature / CPUFANIN Target Speed_L							
DEFAULT	0							

FUNCTION MODE		7	6	5	4	3	2	1	0
Thermal Cruise™	DESCRIPTION	CPUFAN Target Temperature							
Fan Speed Cruise™	DESCRIPTION	CPUFANIN Target Speed [7:0], [11:8] associate index 0C [3:0]							

9.169 CPUFANIN Tolerance_H / Target Speed_H Register – Index 22h (Bank 1)

Attribute: Read/Write

Size: 8 bits

BIT	7	6	5	4	3	2	1	0
NAME	Reserved	CPUFANIN TOL_H			CPUFANIN Target Speed_H			



DEFAULT	0	0	0
---------	---	---	---

BIT	DESCRIPTION
7	Reserved
6-4	CPUFANIN Tolerance_H [5:3]
3-0	CPUFANIN Target Speed_H [11:8]

9.170 CPUFAN MODE Register / CPUFAN TOLLERRANCE Register – Index 23h (Bank 1)

Attribute: Read/Write

Size: 8 bits

BIT	7	6	5	4	3	2	1	0
NAME	CPUFAN MODE				Reserved	Tolerance of CPUFAN Target Temperature or CPUFANIN Target Speed_L		
DEFAULT	0				0	0		

BIT	DESCRIPTION
7-4	CPUFANOUT Mode Select. 0000: CPUFANOUT is in Manual Mode. (Default) 0001: CPUFANOUT is in Thermal Cruise Mode. 0010: CPUFANOUT is in Speed Cruise Mode. 0100: CPUFANOUT is in SMART FAN™ IV Mode.
3	Reserved
2-0	Tolerance of CPUFAN Target Temperature or CPUFANIN Target Speed_L.

9.171 CPUFAN Step Up Time Register – Index 24h (Bank 1)

Attribute: Read/Write

Size: 8 bits

BIT	7	6	5	4	3	2	1	0
NAME	CPUFANOUT Step Up Time Value							
DEFAULT	A							

In SMART FAN™ mode, this register determines the amount of time CPUFANOUT takes to increase its value by one step.

(1) For PWM output:

The units are intervals of 0.1 second. The default time is 1 second.

9.172 CPUFAN Step Down Time Register – Index 25h (Bank 1)

Attribute: Read/Write



Size: 8 bits

BIT	7	6	5	4	3	2	1	0
NAME	CPUFANOUT Step Down Time Value							
DEFAULT	A							

In SMART FAN™ mode, this register determines the amount of time CPUFANOUT takes to decrease its value by one step.

(1) For PWM output:

The units are intervals of 0.1 second. The default time is 1 second.

9.173 CPUFAN Stop Value Register – Index 26h (Bank 1)

Attribute: Read/Write

Size: 8 bits

BIT	7	6	5	4	3	2	1	0
NAME	CPUFANOUT Stop Value							
DEFAULT	1							

In Thermal Cruise mode, the CPUFANOUT value decreases to this eight-bit value if the temperature stays below the lowest temperature limit. This value should not be zero.

Please note that Stop Value does not mean that the fan really stops. It means that if the temperature keeps below low temperature limit, then the fan speed keeps on decreasing until reaching a minimum value, and this is Stop Value.

9.174 CPUFANOUT Start-up Value Register – Index 27h (Bank 1)

Attribute: Read/Write

Size: 8 bits

BIT	7	6	5	4	3	2	1	0
NAME	CPUFANOUT Start-Up Value							
DEFAULT	1							

In Thermal Cruise mode, CPUFANOUT value increases from zero to this eight-bit register value to provide a minimum value to turn on the fan.

9.175 CPUFAN Stop Time Register – Index 28h (Bank 1)

Attribute: Read/Write

Size: 8 bits

BIT	7	6	5	4	3	2	1	0
NAME	CPUFANOUT Stop Time							
DEFAULT	3C							

In Thermal Cruise mode, Define the retention time to the fan stop. It is required by Fan Stop Function.

The time unit is 0.1sec.



9.176 CPUFANOUT Output Value Select Register – Index 29h (Bank 1)

Attribute: Read/Write

Size: 8 bits

BIT	7	6	5	4	3	2	1	0
NAME	CPUFANOUT Value							
DEFAULT	7F							

FUNCTION MODE		7	6	5	4	3	2	1	0
PWM Output (Bank0, Index F3h, bit 1 is 0)	DESCRIPTION	The PWM duty cycle is equal to this eight-bit value, divided by 255, times 100%. FFh creates a duty cycle of 100%, and 00h creates a duty cycle of 0%.							
DC Voltage Output Bank0, Index F3h, bit 1 is 1)	DESCRIPTION	CPUFANOUT voltage control. The output voltage is calculated according to this equation. $\text{OUTPUT Voltage} = V_{ref} * \frac{FANOUT}{64}$ Note. VREF is approx 2.048V.						Reserved	

9.177 CPUFAN Temperature Critical Register – Index 2Ah (Bank 1)

Attribute: Read/Write

Size: 8 bits

BIT	7	6	5	4	3	2	1	0
NAME	CPUFAN Temperature Critical							
DEFAULT	4B							

BIT	DESCRIPTION
7-0	CPUFAN Temperature Critical Register.

9.178 CPUFAN Critical Temperature Tolerance Register – Index 2Bh (Bank 1)

Attribute: Read/Write

Size: 8 bits

BIT	7	6	5	4	3	2	1	0
NAME	Reserved					CPUFANOUT Critical Temperature Tolerance		
DEFAULT	0					0		

BIT	DESCRIPTION
7-3	Reserved
2-0	CPUFAN Critical Temperature Tolerance

9.179 CPUFAN Enable Critical Duty / Fanout Step Register – Index 2Ch (Bank 1)

Publication Release Date: January 11, 2012



Attribute: Read/Write

Size: 8 bits

BIT	7	6	5	4	3	2	1	0
NAME	En_CPU_3WFAN	Reserved		En_CPU_CRITICAL_DUTY	Reserved		En_CPUFANOUT_STEP	
DEFAULT	0	0		0	0		0	

BIT	DESCRIPTION
7	En_CPU_3WFAN 0: 4-wire fan 1: 3-wire fan
6-5	Reserved
4	En_CPU_CRITICAL_DUTY 0: Load default Full Speed 8'hFF for CPUFANOUT. 1: Used Index 1D CRITICAL_DUTY Value for CPUFANOUT.
3-1	Reserved
0	En_CPUFANOUT_STEP 0: Disable SMART FAN™ IV has Stepping CPUFANOUT. 1: Enable SMART FAN™ IV has Stepping CPUFANOUT.

9.180 CPUFAN Critical Duty Register – Index 2Dh (Bank 1)

Attribute: Read/Write

Size: 8 bits

BIT	7	6	5	4	3	2	1	0
NAME	CPUFAN Critical Duty							
DEFAULT	CC							

BIT	DESCRIPTION
7-0	CPUFAN Critical Duty.

9.181 CPUFAN Enable Close Loop Fan Control RPM Mode Register – Index 2Eh (Bank 1)

Attribute: Read/Write

Size: 8 bits

BIT	7	6	5	4	3	2	1	0
NAME	Reserved							En_CPU_RPM
DEFAULT	0							0

BIT	DESCRIPTION
7-1	Reserved
0	En_CPU_RPM



0: Disable SMART FAN™ IV Close Loop Fan Control RPM Mode. 1: Enable SMART FAN™ IV Close Loop Fan Control RPM Mode.

9.182 CPUFAN Enable RPM High Mode / RPM Mode Tolerance Register – Index 2Fh (Bank 1)

Attribute: Read/Write

Size: 8 bits

BIT	7	6	5	4	3	2	1	0
NAME	En_CPU_RPM_High	Reserved			Generic_Tol_RPM			
DEFAULT	0	0			2			

BIT	DESCRIPTION
7	En_CPU_RPM_High For High Speed Fan Control at RPM Mode, the unit is 100 RPM. Support 100 rpm ~ 25500 rpm Fan, 0: Disable 1: Enable
6-4	Reserved
3-0	Tolerance of RPM mode, unit 50 RPM. If Enable RPM High Mode, unit is 100 RPM.

9.183 AUXFAN Monitor Temperature Source Select Register/ STOPDUTY Enable Register – Index 30h (Bank 1)

Attribute: Read/Write

Size: 8 bits

BIT	7	6	5	4	3	2	1	0
NAME	Stopduty_En	Reserved			AUXFAN SOURCE[4:0]			
DEFAULT	0	0			3			

BIT	DESCRIPTION
7	Stopduty_En: 0: FANOUT will decrease to zero value at most if necessary. 1: FANOUT will decrease to AUXFANOUT Stop Value (Bank1, index36h) at most if necessary.
6-5	Reserved
4-0	AUXFAN Temperature Source Select: Bits 4 3 2 1 0 0 0 0 0 1: Select SYSTIN as AUXFAN monitoring source. 0 0 0 1 0: Select CPUTIN as AUXFAN monitoring source. 0 0 0 1 1: Select AUXTIN as AUXFAN monitoring source. (Default) 0 0 1 0 0: Select SMBUSMASTER 0 as AUXFAN monitoring source. 0 0 1 0 1: Select SMBUSMASTER 1 as AUXFAN monitoring source. 0 0 1 1 0: Select SMBUSMASTER 2 as AUXFAN monitoring source.



BIT	DESCRIPTION
0 0 1 1 1	Select SMBUSMASTER 3 as AUXFAN monitoring source.
0 1 0 0 0	Select SMBUSMASTER 4 as AUXFAN monitoring source.
0 1 0 0 1	Select SMBUSMASTER 5 as AUXFAN monitoring source.
0 1 0 1 0	Select SMBUSMASTER 6 as AUXFAN monitoring source.
0 1 0 1 1	Select SMBUSMASTER 7 as AUXFAN monitoring source.
0 1 1 0 0	Select PECI Agent 0 as AUXFAN monitoring source.
0 1 1 0 1	Select PECI Agent 1 as AUXFAN monitoring source.
0 1 1 1 0	Select PCH_CHIP_CPU_MAX_TEMP as AUXFAN monitoring source.
0 1 1 1 1	Select PCH_CHIP_TEMP as AUXFAN monitoring source.
1 0 0 0 0	Select PCH_CPU_TEMP as AUXFAN monitoring source.
1 0 0 0 1	Select PCH_MCH_TEMP as AUXFAN monitoring source.
1 0 0 1 0	Select PCH_DIM0_TEMP as AUXFAN monitoring source.
1 0 0 1 1	Select PCH_DIM1_TEMP as AUXFAN monitoring source.
1 0 1 0 0	Select PCH_DIM2_TEMP as AUXFAN monitoring source.
1 0 1 0 1	Select PCH_DIM3_TEMP as AUXFAN monitoring source.
1 0 1 1 0	Select BYTE_TEMP as AUXFAN monitoring source.

9.184 AUXFAN Target Temperature Register / AUXFANIN Target Speed_L Register – Index 31h (Bank 1)

Attribute: Read/Write

Size: 8 bits

BIT	7	6	5	4	3	2	1	0
NAME	AUXTIN Target Temperature / AUXFANIN Target Speed_L							
DEFAULT	0							

FUNCTION MODE		7	6	5	4	3	2	1	0
Thermal Cruise™	DESCRIPTION	AUXFAN Target Temperature							
Fan Speed Cruise™	DESCRIPTION	AUXFANIN Target Speed [7:0], [11:8] associate index 0C [3:0]							

9.185 AUXFANIN Tolerance_H / Target Speed_H Register – Index 32h (Bank 1)

Attribute: Read/Write

Size: 8 bits

BIT	7	6	5	4	3	2	1	0
NAME	Reserved	AUXFANIN TOL_H			AUXFANIN Target Speed_H			
DEFAULT	0	0			0			

BIT	DESCRIPTION
7	Reserved
6-4	AUXFANIN Tolerance_H [5:3]
3-0	AUXFANIN Target Speed_H [11:8]



9.186 AUXFAN MODE Register / AUXFAN TOLERRANCE Register – Index 33h (Bank 1)

Attribute: Read/Write

Size: 8 bits

BIT	7	6	5	4	3	2	1	0
NAME	AUXFAN MODE				Reserved	Tolerance of AUXFAN Target Temperature or AUXFANIN Target Speed_L		
DEFAULT	0				0	0		

BIT	DESCRIPTION
7-4	AUXFANOUT Mode Select. 0000: AUXFANOUT is in Manual Mode. (Default) 0001: AUXFANOUT is in Thermal Cruise Mode. 0010: AUXFANOUT is as Fan Speed Cruise Mode. 0100: AUXFANOUT is in SMART FAN™ IV Mode.
3	Reserved
2-0	Tolerance of AUXFAN Target Temperature or AUXFANIN Target Speed_L.

9.187 AUXFAN Step Up Time Register – Index 34h (Bank 1)

Attribute: Read/Write

Size: 8 bits

BIT	7	6	5	4	3	2	1	0
NAME	AUXFANOUT Step Up Time Value							
DEFAULT	A							

In SMART FAN™ mode, this register determines the amount of time AUXFANOUT takes to increase its value by one step.

(1) For PWM output:

The units are intervals of 0.1 second. The default time is 1 second.

9.188 AUXFAN Step Down Time Register – Index 35h (Bank 1)

Attribute: Read/Write

Size: 8 bits

BIT	7	6	5	4	3	2	1	0
NAME	AUXFANOUT Step Down Time Value							
DEFAULT	A							

In SMART FAN™ mode, this register determines the amount of time AUXFANOUT takes to decrease its value by one step.

(1) For PWM output:



The units are intervals of 0.1 second. The default time is 1 second.

9.189 AUXFAN Stop Value Register – Index 36h (Bank 1)

Attribute: Read/Write

Size: 8 bits

BIT	7	6	5	4	3	2	1	0
NAME	AUXFANOUT Stop Value							
DEFAULT	1							

In Thermal Cruise mode, the AUXFANOUT value decreases to this eight-bit value if the temperature stays below the lowest temperature limit. This value should not be zero.

Please note that Stop Value does not mean that the fan really stops. It means that if the temperature keeps below low temperature limit, then the fan speed keeps on decreasing until reaching a minimum value, and this is Stop Value.

9.190 AUXFAN Start-up Value Register – Index 37h (Bank 1)

Attribute: Read/Write

Size: 8 bits

BIT	7	6	5	4	3	2	1	0
NAME	AUXFANOUT Start-Up Value							
DEFAULT	1							

In Thermal Cruise mode, AUXFANOUT value increases from zero to this eight-bit register value to provide a minimum value to turn on the fan.

9.191 AUXFAN Stop Time Register – Index 38h (Bank 1)

Attribute: Read/Write

Size: 8 bits

BIT	7	6	5	4	3	2	1	0
NAME	AUXFANOUT Stop Time							
DEFAULT	3C							

In Thermal Cruise mode, Define the retention time to the fan stop. It is required by Fan Stop Function. The time unit is 0.1sec.

9.192 AUXFAN Output Value Select Register – Index 39h (Bank 1)

Attribute: Read/Write

Size: 8 bits

BIT	7	6	5	4	3	2	1	0
NAME	AUXFANOUT Value							
DEFAULT	FF							



FUNCTION MODE		7	6	5	4	3	2	1	0	
PWM Output (Bank0, Index F3h, bit 2 is 0)	DESCRIPTION	The PWM duty cycle is equal to this eight-bit value, divided by 255, times 100%. FFh creates a duty cycle of 100%, and 00h creates a duty cycle of 0%.								
DC Voltage Output Bank0, Index F3h, bit 2 is 1)	DESCRIPTION	AUXFANOUT voltage control. The output voltage is calculated according to this equation. OUTPUT Voltage = $V_{ref} * \frac{FANOUT}{64}$ Note. VREF is approx 2.048V.						Reserved		

9.193 AUXFAN Temperature Critical Register – Index 3Ah (Bank 1)

Attribute: Read/Write

Size: 8 bits

BIT	7	6	5	4	3	2	1	0
NAME	AUXFAN Temperature Critical							
DEFAULT	3C							

BIT	DESCRIPTION
7-0	AUXFAN Temperature Critical Register.

9.194 AUXFAN Critical Temperature Tolerance Register – Index 3Bh (Bank 1)

Attribute: Read/Write

Size: 8 bits

BIT	7	6	5	4	3	2	1	0
NAME	Reserved					AUXFANOUT Critical Temperature Tolerance		
DEFAULT	0					0		

BIT	DESCRIPTION
7-3	Reserved
2-0	AUXFAN Critical Temperature Tolerance

9.195 AUXFAN Enable Critical Duty / Fanout Step Register – Index 3Ch (Bank 1)

Attribute: Read/Write

Size: 8 bits

BIT	7	6	5	4	3	2	1	0
NAME	En_AUX_3WFAN	Reserved		En_AUX_CRITICAL_DUTY	Reserved		En_AUXFANOUT_STEP	
DEFAULT	0	0		0	0		0	



BIT	DESCRIPTION
7	En_AUX_3WFAN 0: 4-wire fan 1: 3-wire fan
6-5	Reserved
4	En_AUX_CRITICAL_DUTY 0: Load default Full Speed 8'hFF for AUXFANOUT. 1: Used Index 1D CRITICAL_DUTY Value for AUXFANOUT.
3-1	Reserved
0	En_AUXFANOUT_STEP 0: Disable SMART FAN™ IV has Stepping AUXFANOUT. 1: Enable SMART FAN™ IV has Stepping AUXFANOUT.

9.196 AUXFAN Critical Duty Register – Index 3Dh (Bank 1)

Attribute: Read/Write

Size: 8 bits

BIT	7	6	5	4	3	2	1	0
NAME	AUXFAN Critical Duty							
DEFAULT	CC							

BIT	DESCRIPTION
7-0	AUXFAN Critical Duty.

9.197 AUXFAN Enable Close Loop Fan Control RPM Mode Register – Index 3Eh (Bank 1)

Attribute: Read/Write

Size: 8 bits

BIT	7	6	5	4	3	2	1	0
NAME	Reserved							En_AUX_RPM
DEFAULT	0							0

BIT	DESCRIPTION
7-1	Reserved
0	En_AUX_RPM 0: Disable SMART FAN™ IV Close Loop Fan Control RPM Mode. 1: Enable SMART FAN™ IV Close Loop Fan Control RPM Mode.

9.198 AUXFAN Enable RPM High Mode / RPM Mode Tolerance Register – Index 3Fh (Bank 1)

Attribute: Read/Write

Size: 8 bits

BIT	7	6	5	4	3	2	1	0
-----	---	---	---	---	---	---	---	---



NAME	En_AUX_RPM_High	Reserved	Generic_Tol_RPM
DEFAULT	0	0	2

BIT	DESCRIPTION
7	En_AUX_RPM_High For High Speed Fan Control at RPM Mode, the unit is 100 RPM. Support 100 rpm ~ 25500 rpm Fan, 0: Disable 1: Enable
6-4	Reserved
3-0	Tolerance of RPM mode, unit 50 RPM. If Enable RPM High Mode, unit is 100 RPM.

9.199 SYSFAN (SMART FAN™ IV) Temperature 1 Register(T1) – Index 60h (Bank 1)

Attribute: Read/Write

Size: 8 bits

BIT	7	6	5	4	3	2	1	0
NAME	SYSFAN (SMART FAN™ IV) Temperature 1							
DEFAULT	19							

BIT	DESCRIPTION
7-0	SYSFAN (SMART FAN™ IV) Temperature 1 Register (T1).

9.200 SYSFAN (SMART FAN™ IV) Temperature 2 Register(T2) – Index 61h (Bank 1)

Attribute: Read/Write

Size: 8 bits

BIT	7	6	5	4	3	2	1	0
NAME	SYSFAN (SMART FAN™ IV) Temperature 2							
DEFAULT	23							

BIT	DESCRIPTION
7-0	SYSFAN (SMART FAN™ IV) Temperature 2 Register (T2).

9.201 SYSFAN (SMART FAN™ IV) Temperature 3 Register(T3) – Index 62h (Bank 1)

Attribute: Read/Write

Size: 8 bits

BIT	7	6	5	4	3	2	1	0
NAME	SYSFAN (SMART FAN™ IV) Temperature 3							
DEFAULT	2D							



BIT	DESCRIPTION
7-0	SYSFAN (SMART FAN™ IV) Temperature 3 Register (T3).

9.202 SYSFAN (SMART FAN™ IV) Temperature 4 Register(T4) – Index 63h (Bank 1)

Attribute: Read/Write

Size: 8 bits

BIT	7	6	5	4	3	2	1	0
NAME	SYSFAN (SMART FAN™ IV) Temperature 4							
DEFAULT	37							

BIT	DESCRIPTION
7-0	SYSFAN (SMART FAN™ IV) Temperature 4 Register (T4).

9.203 SYSFAN (SMART FAN™ IV) FD1/RPM1 Register – Index 64h (Bank 1)

Attribute: Read/Write

Size: 8 bits

BIT	7	6	5	4	3	2	1	0
NAME	SYSFAN (SMART FAN™ IV) FD1/RPM1							
DEFAULT	8C							

BIT	DESCRIPTION
7-0	SYSFAN (SMART FAN™ IV) FD1/RPM1 Register.

9.204 SYSFAN (SMART FAN™ IV) FD2/RPM2 Register – Index 65h (Bank 1)

Attribute: Read/Write

Size: 8 bits

BIT	7	6	5	4	3	2	1	0
NAME	SYSFAN (SMART FAN™ IV) FD2/RPM2							
DEFAULT	AA							

BIT	DESCRIPTION
7-0	SYSFAN (SMART FAN™ IV) FD2/RPM2 Register.

9.205 SYSFAN (SMART FAN™ IV) FD3/RPM3 Register – Index 66h (Bank 1)

Attribute: Read/Write

Size: 8 bits

BIT	7	6	5	4	3	2	1	0
-----	---	---	---	---	---	---	---	---



NAME	SYSFAN (SMART FAN™ IV) FD3/RPM3
DEFAULT	C8

BIT	DESCRIPTION
7-0	SYSFAN (SMART FAN™ IV) FD3/RPM3 Register.

9.206 SYSFAN (SMART FAN™ IV) FD4/RPM4 Register – Index 67h (Bank 1)

Attribute: Read/Write

Size: 8 bits

BIT	7	6	5	4	3	2	1	0
NAME	SYSFAN (SMART FAN™ IV) FD4/RPM4							
DEFAULT	E6							

BIT	DESCRIPTION
7-0	SYSFAN (SMART FAN™ IV) FD4/RPM4 Register.

9.207 SYSFAN Weight value Configuration Register – Index 68h (Bank 1)

Attribute: Read/Write

Size: 8 bits

BIT	7	6	5	4	3	2	1	0
NAME	EN_SYSFAN_WEIGHT	Reserved			SYS_WEIGHT_SEL			
DEFAULT	0	0			1			

BIT	DESCRIPTION
7	EN_SYSFAN_WEIGHT. 0: Disable Weight Value Control for SYSFAN. 1: Enable Weight Value Control for SYSFAN.
6-5	Reserved
4-0	SYSFAN Weighting Temperature Source Select: Bits 4 3 2 1 0 0 0 0 0 1: Select SYSTIN as SYSFAN monitoring source. (Default) 0 0 0 1 0: Select CPUTIN as SYSFAN monitoring source. 0 0 0 1 1: Select AUXTIN as SYSFAN monitoring source. 0 0 1 0 0: Select SMBUSMASTER 0 as SYSFAN monitoring source. 0 0 1 0 1: Select SMBUSMASTER 1 as SYSFAN monitoring source. 0 0 1 1 0: Select SMBUSMASTER 2 as SYSFAN monitoring source. 0 0 1 1 1: Select SMBUSMASTER 3 as SYSFAN monitoring source. 0 1 0 0 0: Select SMBUSMASTER 4 as SYSFAN monitoring source. 0 1 0 0 1: Select SMBUSMASTER 5 as SYSFAN monitoring source. 0 1 0 1 0: Select SMBUSMASTER 6 as SYSFAN monitoring source.



BIT	DESCRIPTION
0 1 0 1 1	Select SMBUSMASTER 7 as SYSFAN monitoring source.
0 1 1 0 0	Select PECI Agent 0 as SYSFAN monitoring source.
0 1 1 0 1	Select PECI Agent 1 as SYSFAN monitoring source.
0 1 1 1 0	Select PCH_CHIP_CPU_MAX_TEMP as SYSFAN monitoring source.
0 1 1 1 1	Select PCH_CHIP_TEMP as SYSFAN monitoring source.
1 0 0 0 0	Select PCH_CPU_TEMP as SYSFAN monitoring source.
1 0 0 0 1	Select PCH_MCH_TEMP as SYSFAN monitoring source.
1 0 0 1 0	Select PCH_DIM0_TEMP as SYSFAN monitoring source.
1 0 0 1 1	Select PCH_DIM1_TEMP as SYSFAN monitoring source.
1 0 1 0 0	Select PCH_DIM2_TEMP as SYSFAN monitoring source.
1 0 1 0 1	Select PCH_DIM3_TEMP as SYSFAN monitoring source.
1 0 1 1 0	Select BYTE_TEMP as SYSFAN monitoring source.

9.208 SYSFAN Weight Temperature Step Register – Index 69h (Bank 1)

Attribute: Read/Write

Size: 8 bits

BIT	7	6	5	4	3	2	1	0
NAME	SYSFANOUT Temperature Step (SYS_TEMP_STEP)							
DEFAULT	0							

BIT	DESCRIPTION
7-0	SYSFANOUT Temperature Step

9.209 SYSFAN Weight Temperature Step Tolerance Register – Index 6Ah (Bank 1)

Attribute: Read/Write

Size: 8 bits

BIT	7	6	5	4	3	2	1	0
NAME	SYSFANOUT Temperature Step Tolerance (SYS_TEMP_STEP_TOL)							
DEFAULT	0							

BIT	DESCRIPTION
7-0	SYSFANOUT Temperature Step Tolerance

9.210 SYSFAN Weight Step Register – Index 6Bh (Bank 1)

Attribute: Read/Write

Size: 8 bits

BIT	7	6	5	4	3	2	1	0
NAME	SYSFANOUT Weight Step (SYS_WEIGHT_STEP)							
DEFAULT	0							



BIT	DESCRIPTION
7-0	SYSFANOUT Weight Step

9.211 SYSFAN Weight Temperature Base Register – Index 6Ch (Bank 1)

Attribute: Read/Write

Size: 8 bits

BIT	7	6	5	4	3	2	1	0
NAME	SYSFANOUT Temperature Base (SYS_TEMP_BASE)							
DEFAULT	0							

BIT	DESCRIPTION
7-0	SYSFANOUT Temperature Base

9.212 SYSFAN Weight Fan Duty Base Register – index 6Dh (Bank 1)

Attribute: Read/Write

Size: 8 bits

BIT	7	6	5	4	3	2	1	0
NAME	SYSFANOUT Temperature Base (SYS_DUTY_BASE)							
DEFAULT	0							

BIT	DESCRIPTION
7-0	SYSFANOUT Start point of Fan Duty increasing

9.213 SYSFAN Enable PECIERR DUTY Register – Index 6Eh (Bank 1)

Attribute: Read/Write

Size: 8 bits

BIT	7	6	5	4	3	2	1	0
NAME	Reserved						EN_SYS_PECIERR_DUTY	
DEFAULT	0						0	0

BIT	DESCRIPTION
7-2	Reserved
1-0	EN_SYS_PECIERR_DUTY 00: Disable PECIERR DUTY FANOUT (default) 01: Enable PECIERR DUTY FANOUT 10,11: Keep Full Speed

9.214 SYSFAN Pre-Configured Register For PECI Error – Index 6Fh (Bank 1)

Attribute: Read/Write



Size: 8 bits

BIT	7	6	5	4	3	2	1	0
NAME	SYSFANOUT pre-configured register for PECL error (PECL_ERR_SYSOUT)							
DEFAULT	FF							

BIT	DESCRIPTION
7-0	SYSFANOUT pre-configured register for PECL error.

9.215 CPUFAN (SMART FAN™ IV) Temperature 1 Register(T1) – Index 70h (Bank 1)

Attribute: Read/Write

Size: 8 bits

BIT	7	6	5	4	3	2	1	0
NAME	CPUFAN (SMART FAN™ IV) Temperature 1							
DEFAULT	28							

BIT	DESCRIPTION
7-0	CPUFAN (SMART FAN™ IV) Temperature 1 Register (T1).

9.216 CPUFAN (SMART FAN™ IV) Temperature 2 Register(T2) – Index 71h (Bank 1)

Attribute: Read/Write

Size: 8 bits

BIT	7	6	5	4	3	2	1	0
NAME	CPUFAN (SMART FAN™ IV) Temperature 2							
DEFAULT	32							

BIT	DESCRIPTION
7-0	CPUFAN (SMART FAN™ IV) Temperature 2 Register (T2).

9.217 CPUFAN (SMART FAN™ IV) Temperature 3 Register(T3) – Index 72h (Bank 1)

Attribute: Read/Write

Size: 8 bits

BIT	7	6	5	4	3	2	1	0
NAME	CPUFAN (SMART FAN™ IV) Temperature 3							
DEFAULT	3C							

BIT	DESCRIPTION
7-0	CPUFAN (SMART FAN™ IV) Temperature 3 Register (T3).



9.218 CPUFAN (SMART FAN™ IV) Temperature 4 Register(T4) – Index 73h (Bank 1)

Attribute: Read/Write

Size: 8 bits

BIT	7	6	5	4	3	2	1	0
NAME	CPUFAN (SMART FAN™ IV) Temperature 4							
DEFAULT	46							

BIT	DESCRIPTION
7-0	CPUFAN (SMART FAN™ IV) Temperature 4 Register (T4).

9.219 CPUFAN (SMART FAN™ IV) FD1/RPM1 Register – Index 74h (Bank 1)

Attribute: Read/Write

Size: 8 bits

BIT	7	6	5	4	3	2	1	0
NAME	CPUFAN (SMART FAN™ IV) FD1/RPM1							
DEFAULT	8C							

BIT	DESCRIPTION
7-0	CPUFAN (SMART FAN™ IV) FD1/RPM1 Register.

9.220 CPUFAN (SMART FAN™ IV) FD2/RPM2 Register – Index 75h (Bank 1)

Attribute: Read/Write

Size: 8 bits

BIT	7	6	5	4	3	2	1	0
NAME	CPUFAN (SMART FAN™ IV) FD2/RPM2							
DEFAULT	AA							

BIT	DESCRIPTION
7-0	CPUFAN (SMART FAN™ IV) FD2/RPM2 Register.

9.221 CPUFAN (SMART FAN™ IV) FD3/RPM3 Register – Index 76h (Bank 1)

Attribute: Read/Write

Size: 8 bits

BIT	7	6	5	4	3	2	1	0
NAME	CPUFAN (SMART FAN™ IV) FD3/RPM3							
DEFAULT	C8							

BIT	DESCRIPTION
7-0	CPUFAN (SMART FAN™ IV) FD3/RPM3 Register.



7-0	CPUFAN (SMART FAN™ IV) FD3/RPM3 Register.
-----	---

9.222 CPUFAN (SMART FAN™ IV) FD4/RPM4 Register – Index 77h (Bank 1)

Attribute: Read/Write

Size: 8 bits

BIT	7	6	5	4	3	2	1	0
NAME	CPUFAN (SMART FAN™ IV) FD4/RPM4							
DEFAULT	E6							

BIT	DESCRIPTION
7-0	CPUFAN (SMART FAN™ IV) FD4/RPM4 Register.

9.223 CPUFAN Weight value Configuration Register – Index 78h (Bank 1)

Attribute: Read/Write

Size: 8 bits

BIT	7	6	5	4	3	2	1	0
NAME	EN_CPUFAN_WEIGHT	Reserved			CPU_WEIGHT_SEL			
DEFAULT	0	0			1			

BIT	DESCRIPTION
7	EN_CPUFAN_WEIGHT. 0: Disable Weight Value Control for CPUFAN. 1: Enable Weight Value Control for CPUFAN.
6-5	Reserved
4-0	CPUFAN Weighting Temperature Source Select: Bits 4 3 2 1 0 0 0 0 0 1: Select SYSTIN as CPUFAN monitoring source. (Default) 0 0 0 1 0: Select CPUTIN as CPUFAN monitoring source. 0 0 0 1 1: Select AUXTIN as CPUFAN monitoring source. 0 0 1 0 0: Select SMBUSMASTER as CPUFAN monitoring source. 0 0 1 0 0: Select SMBUSMASTER 0 as CPUFAN monitoring source. 0 0 1 0 1: Select SMBUSMASTER 1 as CPUFAN monitoring source. 0 0 1 1 0: Select SMBUSMASTER 2 as CPUFAN monitoring source. 0 0 1 1 1: Select SMBUSMASTER 3 as CPUFAN monitoring source. 0 1 0 0 0: Select SMBUSMASTER 4 as CPUFAN monitoring source. 0 1 0 0 1: Select SMBUSMASTER 5 as CPUFAN monitoring source. 0 1 0 1 0: Select SMBUSMASTER 6 as CPUFAN monitoring source. 0 1 0 1 1: Select SMBUSMASTER 7 as CPUFAN monitoring source. 0 1 1 0 0: Select PECI Agent 0 as CPUFAN monitoring source. 0 1 1 0 1: Select PECI Agent 1 as CPUFAN monitoring source. 0 1 1 1 0: Select PCH_CHIP_CPU_MAX_TEMP as CPUFAN monitoring source.



BIT	DESCRIPTION
0 1 1 1 1	Select PCH_CHIP_TEMP as CPUFAN monitoring source.
1 0 0 0 0	Select PCH_CPU_TEMP as CPUFAN monitoring source.
1 0 0 0 1	Select PCH_MCH_TEMP as CPUFAN monitoring source.
1 0 0 1 0	Select PCH_DIM0_TEMP as CPUFAN monitoring source.
1 0 0 1 1	Select PCH_DIM1_TEMP as CPUFAN monitoring source.
1 0 1 0 0	Select PCH_DIM2_TEMP as CPUFAN monitoring source.
1 0 1 0 1	Select PCH_DIM3_TEMP as CPUFAN monitoring source.
1 0 1 1 0	Select BYTE_TEMP as CPUFAN monitoring source.

9.224 CPUFAN Weight Temperature Step Register – Index 79h (Bank 1)

Attribute: Read/Write

Size: 8 bits

BIT	7	6	5	4	3	2	1	0
BIT	CPUFANOUT Temperature Step (CPU_TEMP_STEP)							
DEFAULT	0							

BIT	DESCRIPTION
7-0	CPUFANOUT Temperature Step

9.225 CPUFAN Weight Temperature Step Tolerance Register – Index 7Ah (Bank 1)

Attribute: Read/Write

Size: 8 bits

BIT	7	6	5	4	3	2	1	0
BIT	CPUFANOUT Temperature Step Tolerance (CPU_TEMP_STEP_TOL)							
DEFAULT	0							

BIT	DESCRIPTION
7-0	CPUFANOUT Temperature Step Tolerance

9.226 CPUFAN Weight Step Register – Index 7Bh (Bank 1)

Attribute: Read/Write

Size: 8 bits

BIT	7	6	5	4	3	2	1	0
BIT	CPUFANOUT Weight Step (CPU_WEIGHT_STEP)							
DEFAULT	0							

BIT	DESCRIPTION
7-0	CPUFANOUT Weight Step



9.227 CPUFAN Weight Temperature Base Register – Index 7Ch (Bank 1)

Attribute: Read/Write

Size: 8 bits

BIT	7	6	5	4	3	2	1	0
NAME	CPUFANOUT Temperature Base (CPU_TEMP_BASE)							
DEFAULT	0							

BIT	DESCRIPTION
7-0	CPUFANOUT Temperature Base

9.228 CPUFAN Weight Fan Duty Base Register – Index 7Dh (Bank 1)

Attribute: Read/Write

Size: 8 bits

BIT	7	6	5	4	3	2	1	0
NAME	CPUFANOUT Temperature Base (CPU_DUTY_BASE)							
DEFAULT	0							

BIT	DESCRIPTION
7-0	CPUFANOUT Start point of Fan Duty increasing

9.229 CPUFAN Enable PECIERR DUTY Register – Index 7Eh (Bank 1)

Attribute: Read/Write

Size: 8 bits

BIT	7	6	5	4	3	2	1	0
BIT	Reserved						EN_CPU_PECIERR_DUTY	
DEFAULT	0						0	0

BIT	DESCRIPTION
7-2	Reserved
1-0	EN_CPU_PECIERR_DUTY 00: Disable PECIERR DUTY FANOUT (default) 01: Enable PECIERR DUTY FANOUT 10,11: Keep Full Speed

9.230 CPUFAN Pre-Configured Register For PECI Error – Index 7Fh (Bank 1)

Attribute: Read/Write

Size: 8 bits

BIT	7	6	5	4	3	2	1	0
NAME	CPUFANOUT pre-configured register for PECI error (PECI_ERR_CPUOUT)							
DEFAULT	FF							



BIT	DESCRIPTION
7-0	CPUFANOUT pre-configured register for PECl error.

9.231 AUXFAN (SMART FAN™ IV) Temperature 1 Register(T1) – Index 80h (Bank 1)

Attribute: Read/Write

Size: 8 bits

BIT	7	6	5	4	3	2	1	0
NAME	AUXFAN (SMART FAN™ IV) Temperature 1							
DEFAULT	19							

BIT	DESCRIPTION
7-0	AUXFAN (SMART FAN™ IV) Temperature 1 Register (T1).

9.232 AUXFAN (SMART FAN™ IV) Temperature 2 Register(T2) – Index 81h (Bank 1)

Attribute: Read/Write

Size: 8 bits

BIT	7	6	5	4	3	2	1	0
NAME	AUXFAN (SMART FAN™ IV) Temperature 2							
DEFAULT	23							

BIT	DESCRIPTION
7-0	AUXFAN (SMART FAN™ IV) Temperature 2 Register (T2).

9.233 AUXFAN (SMART FAN™ IV) Temperature 3 Register(T3) – Index 82h (Bank 1)

Attribute: Read/Write

Size: 8 bits

BIT	7	6	5	4	3	2	1	0
NAME	AUXFAN (SMART FAN™ IV) Temperature 3							
DEFAULT	2D							

BIT	DESCRIPTION
7-0	AUXFAN (SMART FAN™ IV) Temperature 3 Register (T3).

9.234 AUXFAN (SMART FAN™ IV) Temperature 4 Register(T4) – Index 83h (Bank 1)

Attribute: Read/Write

Size: 8 bits

BIT	7	6	5	4	3	2	1	0
-----	---	---	---	---	---	---	---	---



NAME	AUXFAN (SMART FAN™ IV) Temperature 4
DEFAULT	37

BIT	DESCRIPTION
7-0	AUXFAN (SMART FAN™ IV) Temperature 4 Register (T4).

9.235 AUXFAN (SMART FAN™ IV) FD1/RPM1 Register – Index 84h (Bank 1)

Attribute: Read/Write

Size: 8 bits

BIT	7	6	5	4	3	2	1	0
NAME	AUXFAN (SMART FAN™ IV) FD1/RPM1							
DEFAULT	8C							

BIT	DESCRIPTION
7-0	AUXFAN (SMART FAN™ IV) FD1/RPM1 Register.

9.236 AUXFAN (SMART FAN™ IV) FD2/RPM2 Register – Index 85h (Bank 1)

Attribute: Read/Write

Size: 8 bits

BIT	7	6	5	4	3	2	1	0
NAME	AUXFAN (SMART FAN™ IV) FD2/RPM2							
DEFAULT	AA							

BIT	DESCRIPTION
7-0	AUXFAN (SMART FAN™ IV) FD2/RPM2 Register.

9.237 AUXFAN (SMART FAN™ IV) FD3/RPM3 Register – Index 86h (Bank 1)

Attribute: Read/Write

Size: 8 bits

BIT	7	6	5	4	3	2	1	0
NAME	AUXFAN (SMART FAN™ IV) FD3/RPM3							
DEFAULT	C8							

BIT	DESCRIPTION
7-0	AUXFAN (SMART FAN™ IV) FD3/RPM3 Register.

9.238 AUXFAN (SMART FAN™ IV) FD4/RPM4 Register – Index 87h (Bank 1)

Attribute: Read/Write



Size: 8 bits

BIT	7	6	5	4	3	2	1	0
NAME	AUXFAN (SMART FAN™ IV) FD4/RPM4							
DEFAULT	E6							

BIT	DESCRIPTION
7-0	AUXFAN (SMART FAN™ IV) FD4/RPM4 Register.

9.239 AUXFAN Weight value Configuration Register – Index 88h (Bank 1)

Attribute: Read/Write

Size: 8 bits

BIT	7	6	5	4	3	2	1	0
NAME	EN_AUXFAN_WEIGHT	Reserved			AUX_WEIGHT_SEL			
DEFAULT	0	0			1			

BIT	DESCRIPTION
7	EN_AUXFAN_WEIGHT. 0: Disable Weight Value Control for AUXFAN. 1: Enable Weight Value Control for AUXFAN.
6-5	Reserved
4-0	AUXFAN Weighting Temperature Source Select: Bits 4 3 2 1 0 0 0 0 0 1: Select SYSTIN as AUXFAN monitoring source. (Default) 0 0 0 1 0: Select CPUTIN as AUXFAN monitoring source. 0 0 0 1 1: Select AUXTIN as AUXFAN monitoring source. 0 0 1 0 0: Select SMBUSMASTER 0 as AUXFAN monitoring source. 0 0 1 0 1: Select SMBUSMASTER 1 as AUXFAN monitoring source. 0 0 1 1 0: Select SMBUSMASTER 2 as AUXFAN monitoring source. 0 0 1 1 1: Select SMBUSMASTER 3 as AUXFAN monitoring source. 0 1 0 0 0: Select SMBUSMASTER 4 as AUXFAN monitoring source. 0 1 0 0 1: Select SMBUSMASTER 5 as AUXFAN monitoring source. 0 1 0 1 0: Select SMBUSMASTER 6 as AUXFAN monitoring source. 0 1 0 1 1: Select SMBUSMASTER 7 as AUXFAN monitoring source. 0 1 1 0 0: Select PECI Agent 0 as AUXFAN monitoring source. 0 1 1 0 1: Select PECI Agent 1 as AUXFAN monitoring source. 0 1 1 1 0: Select PCH_CHIP_CPU_MAX_TEMP as AUXFAN monitoring source. 0 1 1 1 1: Select PCH_CHIP_TEMP as AUXFAN monitoring source. 1 0 0 0 0: Select PCH_CPU_TEMP as AUXFAN monitoring source. 1 0 0 0 1: Select PCH_MCH_TEMP as AUXFAN monitoring source. 1 0 0 1 0: Select PCH_DIM0_TEMP as AUXFAN monitoring source. 1 0 0 1 1: Select PCH_DIM1_TEMP as AUXFAN monitoring source. 1 0 1 0 0: Select PCH_DIM2_TEMP as AUXFAN monitoring source.



BIT	DESCRIPTION
1 0 1 0 1	Select PCH_DIM3_TEMP as AUXFAN monitoring source.
1 0 1 1 0	Select BYTE_TEMP as AUXFAN monitoring source.

9.240 AUXFAN Weight Temperature Step Register – Index 89h (Bank 1)

Attribute: Read/Write

Size: 8 bits

BIT	7	6	5	4	3	2	1	0
NAME	AUXFANOUT Temperature Step (AUX_TEMP_STEP)							
DEFAULT	0							

BIT	DESCRIPTION
7-0	AUXFANOUT Temperature Step

9.241 AUXFAN Weight Temperature Step Tolerance Register – Index 8Ah (Bank 1)

Attribute: Read/Write

Size: 8 bits

BIT	7	6	5	4	3	2	1	0
NAME	AUXFANOUT Temperature Step Tolerance (AUX_TEMP_STEP_TOL)							
DEFAULT	0							

BIT	DESCRIPTION
7-0	AUXFANOUT Temperature Step Tolerance

9.242 AUXFAN Weight Step Register – Index 8Bh (Bank 1)

Attribute: Read/Write

Size: 8 bits

BIT	7	6	5	4	3	2	1	0
NAME	AUXFANOUT Weight Step (AUX_WEIGHT_STEP)							
DEFAULT	0							

BIT	DESCRIPTION
7-0	AUXFANOUT Weight Step

9.243 AUXFAN Weight Temperature Base Register – Index 8Ch (Bank 1)

Attribute: Read/Write

Size: 8 bits

BIT	7	6	5	4	3	2	1	0
-----	---	---	---	---	---	---	---	---



NAME	AUXFANOUT Temperature Base (AUX_TEMP_BASE)
DEFAULT	0

BIT	DESCRIPTION
7-0	AUXFANOUT Temperature Base

9.244 AUXFAN Weight Fan Duty Base Register – Index 8Dh (Bank 1)

Attribute: Read/Write

Size: 8 bits

BIT	7	6	5	4	3	2	1	0
NAME	AUXFANOUT Temperature Base (AUX_DUTY_BASE)							
DEFAULT	0							

BIT	DESCRIPTION
7-0	AUXFANOUT Start point of Fan Duty increasing

9.245 AUXFAN Enable PECIERR DUTY Register – Index 8Eh (Bank 1)

Attribute: Read/Write

Size: 8 bits

BIT	7	6	5	4	3	2	1	0
NAME	Reserved						EN_AUX_PECIERR_DUTY	
DEFAULT	0						0	

BIT	DESCRIPTION
7-2	Reserved
1-0	EN_AUX_PECIERR_DUTY 00: Disable PECIERR DUTY FANOUT (default) 01: Enable PECIERR DUTY FANOUT 10,11: Keep Full Speed

9.246 AUXFAN Pre-Configured Register For PECI Error – Index 8Fh (Bank 1)

Attribute: Read/Write

Size: 8 bits

BIT	7	6	5	4	3	2	1	0
NAME	AUXFANOUT pre-configured register for PECI error (PECI_ERR_AUXOUT)							
DEFAULT	FF							

BIT	DESCRIPTION
7-0	AUXFANOUT pre-configured register for PECI error.



9.247 Reserved Register – Index 90h~FF (Bank 1)

9.248 PECI Function Control Registers – Index 00 ~ 03h (Bank 2)

9.249 PECI Enable Function Register – Index 00h (Bank 2)

Attribute: Read/Write

Size: 8 bits

BIT	7	6	5	4	3	2	1	0
NAME	PECI_En	Reserved				Is_PECI30	Manual_En	Routine_En
DEFAULT	0	0	0	0	0	1	0	1

BIT	READ / WRITE	DESCRIPTION
7	R / W	Enable PECI Function.(PECI_En)
6 ~ 3	R / W	Reserved
2	R / W	Enable PECI 3.0 Command function (Is_PECI30)
1	R / W	Enable PECI Manual Function(Manual_En)
0	R / W	Enable PECI Routine Function(Routine_En)

9.250 PECI Timing Config Register – Index 01h (Bank 2)

Attribute: Read/Write

Size: 8 bits

BIT	7	6	5	4	3	2	1	0
NAME	Reserved		TN_Extend		Adj[2 :0]			PECI_DC
DEFAULT	0	0	0	0	0	0	1	0

BIT	READ / WRITE	DESCRIPTION
7 ~ 6	R / W	Reserve
5	R / W	TN_Extend[1:0] Adjust Transaction Rate. 00 _{BIN} = 1.5 MHz
4	R / W	01 _{BIN} = 750 KHz 10 _{BIN} = 375 KHz 11 _{BIN} = 187.5 KHz
3	R / W	Adj[2:0]
2	R / W	Compensate the effect of rising time on physical bus
1	R / W	Default Value = 001
0	R / W	Adjust PECI Tbit Duty cycle selection. (PECI_DC) 0 = 75% Tbit high duty cycle time. (Default) 1 = 68% Tbit high duty cycle time.



9.251 PECE Agent Config Register – Index 02h (Bank 2)

Attribute: Read/Write

Size: 8 bits

BIT	7	6	5	4	3	2	1	0
NAME	Reserved		En_Agt[1:0]		Reserved		Dmn1_Agt[1:0]	
DEFAULT	0	0	0	0	0	0	0	0

BIT	READ / WRITE	DESCRIPTION
7 ~ 6	R / W	Reserved
5	R / W	PECE host to process related agent 31 Enable or Disable. 0 = Agent Disable 1 = Agent Enable
4	R / W	PECE host to process related agent 30 Enable or Disable. 0 = Agent Disable 1 = Agent Enable
3 ~ 2	R / W	Reserved
1	R / W	Indicate agent 31 domain1. 0 = Agent does not have domain 1. 1 = Agent has domain 1.
0	R / W	Indicate agent 30 domain1. 0 = Agent does not have domain 1. 1 = Agent has domain 1.

9.252 PECE Temperature Config Register – Index 03h (Bank 2)

Attribute: Read/Write

Size: 8 bits

BIT	7	6	5	4	3	2	1	0
NAME	Virtual_En	Reserved		Clamp	Reserved	RtDmn_Agt[1 :0]		RtHigher
DEFAULT	0	0	0	0	0	0	0	0

BIT	READ / WRITE	DESCRIPTION
7	R / W	Virtual Temp Function Enable.(Virtual_En) When enable this function, the temperature raw data can use LPC to write raw data to Bank7 CR 17 _{HEX} ~ CR 1E _{HEX}
6 ~ 5	R / W	Reserved
4	R / W	When temperature data reading is positive or less than -128, can enable this function to clamp temperature data.(Clamp)
3	R / W	Reserved



BIT	READ / WRITE	DESCRIPTION
2	R / W	Agent 31 always return the relative domain Temperature. 0 = Agent always returns the relative temperature from domain 0. 1 = Agent always returns the relative temperature from domain 1.
1	R / W	Agent 30 always return the relative domain Temperature. 0 = Agent always returns the relative temperature from domain 0. 1 = Agent always returns the relative temperature from domain 1.
0	R / W	Return High Temperature of doamin0 or domain1.(RtHigher) 0 = The temperature of each agent is returned from domain 0 or domain 1, which is controlled by (CR 04 _{HEX}) 1 = Return the highest temperature in domain 0 and domain 1 of individual Agent.

9.253 PECE Command Tbase0 Register – Index 04h (Bank 2)

Attribute: Read/Write

Size: 8 bits

BIT	7	6	5	4	3	2	1	0
NAME	Reserved	Tbase 0						
DEFAULT	0	0	0	0	0	0	0	0

BIT	DESCRIPTION
7~0	Agent0 base temperature for calculating agent0 absolute temperature.

9.254 PECE Command Tbase1 Register – Index 05h (Bank 2)

Attribute: Read/Write

Size: 8 bits

BIT	7	6	5	4	3	2	1	0
NAME	Reserved	Tbase 1						
DEFAULT	0	0	0	0	0	0	0	0

BIT	DESCRIPTION
7~0	Agent1 base temperature for calculating agent1 absolute temperature.

9.255 PECE Agent Relative Temperature Register – Index 06h-0Dh (Bank 2)

These registers return the raw data retrieved from PECE GetTemp(). The data may be the error code (range: 8000H~81FFH) or relative temperatures to process the defined **Tbase**. The error code will only be update in **ARTR** and absolute Temperature will not be updated when the error code is received. If the **RtHigher** mechanism is activated, the normal temperature will always be returned first. In case both 2 domains return errors, the return priority will be Overflow Error > Underflow Error > Missing Diode > General Error. The reset value is 8001_{HEX}, in that PECE is defaulted to be off. In PECE, 8001_{HEX} means the diode is missing.

Attribute: Read / Write(When Virtual_En enable)

ADDRESS 17-1E	DESCRIPTION
06h[15:8],07h[7:0]	Domain0 Relative Temperature Agent0 [15:0]
08h[15:8],09h[7:0]	Domain1 Relative Temperature Agent0 [15:0]
0Ah[15:8],0Bh[7:0]	Domain0 Relative Temperature Agent1 [15:0]
0Ch[15:8],0Dh[7:0]	Domain1 Relative Temperature Agent1 [15:0]

GetTemp() PECL Temperature format:

BIT	DESCRIPTION
15	Sign Bit. (Sign) In PECL Protocol, this bit should always be 1 to represent a negative temperature.
14-6	The integer part of the relative temperature. (Temperature[8:0])
5	TEMP_2 . 0.5°C unit.
4	TEMP_4 . 0.25°C unit.
3	TEMP_8 . 0.125°C unit.
2	TEMP_16 . 0.0625°C unit.
1	TEMP_32 . 0.03125°C unit.
0	TEMP_64 . 0.015625°C unit.

GetTemp() Response Definition:

RESPONSE	MEANING
General Sensor Error (GSE)	Thermal scan did not complete in time. Retry is appropriate.
0x0000	Processor is running at its maximum temperature or is currently being reset.
All other data	Valid temperature reading, reported as a negative offset from the TCC activation temperature. The valide temperature reading is referred to <u>GetTemp() PECL Temperature format</u>

Error Code	Description	Host operation
8000 _{HEX}	General Sensor Error	No further processing.
8001 _{HEX}	Sensing Device Missing	
8002 _{HEX}	Operational, but the temperature is lower than the sensor operation range.	Compulsorily write 0°C back to the temperature readouts.
8003 _{HEX}	Operational, but the temperature is higher than the sensor operation range.	Compulsorily write 127°C back to the temperature readouts.
8004 _{HEX}	Reserved.	No further operation.



Error Code	Description	Host operation
81FF _{HEX}		

9.256 PECI Command Write Date Registers – Index 10 ~ 1Fh (Bank 2)

9.257 PECI Command Address Register – Index 10h (Bank 2)

Attribute: Read/Write

Size: 8 bits

BIT	7	6	5	4	3	2	1	0
NAME	PECI Command Address							
DEFAULT	0	0	0	0	0	0	0	0

BIT	DESCRIPTION
7~0	The data would be sent to client through issuing Manual Command.

9.258 PECI Command Write Length Register – Index 11h (Bank 2)

Attribute: Read/Write

Size: 8 bits

BIT	7	6	5	4	3	2	1	0
NAME	PECI Command Write Length							
DEFAULT	0	0	0	0	0	0	0	0

BIT	DESCRIPTION
7~0	The data would be sent to client through issuing Manual Command.

9.259 PECI Command Read Length Register – Index 12h (Bank 2)

Attribute: Read/Write

Size: 8 bits

BIT	7	6	5	4	3	2	1	0
NAME	PECI Command Read Length							
DEFAULT	0	0	0	0	0	0	0	0

BIT	DESCRIPTION
7~0	The data would be sent to client through issuing Manual Command.

9.260 ECI Command Code Register – Index 13h (Bank 2)

Attribute: Read/Write



Size: 8 bits

BIT	7	6	5	4	3	2	1	0
NAME	PECI Command Code							
DEFAULT	0	0	0	0	0	0	0	0

BIT	DESCRIPTION
7~0	The data would be sent to client through issuing Manual Command.

9.261 Peci Command Write Data 1 Register – Index 14h (Bank 2)

Attribute: Read/Write

Size: 8 bits

BIT	7	6	5	4	3	2	1	0
NAME	PECI Write Data 1							
DEFAULT	0	0	0	0	0	0	0	0

BIT	DESCRIPTION
7~0	The data would be sent to client through issuing Manual Command.

9.262 Peci Command Write Data 2 Register – Index 15h (Bank 2)

Attribute: Read/Write

Size: 8 bits

BIT	7	6	5	4	3	2	1	0
NAME	PECI Write Data 2							
DEFAULT	0	0	0	0	0	0	0	0

BIT	DESCRIPTION
7~0	The data would be sent to client through issuing Manual Command.

9.263 Peci Command Write Data 3 Register – Index 16h (Bank 2)

Attribute: Read/Write

Size: 8 bits

BIT	7	6	5	4	3	2	1	0
NAME	PECI Write Data 3							
DEFAULT	0	0	0	0	0	0	0	0

BIT	DESCRIPTION
7~0	The data would be sent to client through issuing Manual Command.



9.264 PECE Command Write Data 4 Register – Index 17h (Bank 2)

Attribute: Read/Write

Size: 8 bits

BIT	7	6	5	4	3	2	1	0
NAME	PECE Write Data 4							
DEFAULT	0	0	0	0	0	0	0	0

BIT	DESCRIPTION
7~0	The data would be sent to client through issuing Manual Command.

9.265 PECE Command Write Data 5 Register – Index 18h (Bank 2)

Attribute: Read/Write

Size: 8 bits

BIT	7	6	5	4	3	2	1	0
NAME	PECE Write Data 5							
DEFAULT	0	0	0	0	0	0	0	0

BIT	DESCRIPTION
7~0	The data would be sent to client through issuing Manual Command.

9.266 PECE Command Write Data 6 Register – Index 19h (Bank 2)

Attribute: Read/Write

Size: 8 bits

BIT	7	6	5	4	3	2	1	0
NAME	PECE Write Data 6							
DEFAULT	0	0	0	0	0	0	0	0

BIT	DESCRIPTION
7~0	The data would be sent to client through issuing Manual Command.

9.267 PECE Command Write Data 7 Register – Index 1Ah (Bank 2)

Attribute: Read/Write

Size: 8 bits

BIT	7	6	5	4	3	2	1	0
-----	---	---	---	---	---	---	---	---



NAME	PECI Write Data 7							
DEFAULT	0	0	0	0	0	0	0	0

BIT	DESCRIPTION
7~0	The data would be sent to client through issuing Manual Command.

9.268 Peci Command Write Data 8 Register – Index 1Bh (Bank 2)

Attribute: Read/Write

Size: 8 bits

BIT	7	6	5	4	3	2	1	0
NAME	PECI Write Data 8							
DEFAULT	0	0	0	0	0	0	0	0

BIT	DESCRIPTION
7~0	The data would be sent to client through issuing Manual Command.

9.269 Peci Command Write Data 9 Register – Index 1Ch (Bank 2)

Attribute: Read/Write

Size: 8 bits

BIT	7	6	5	4	3	2	1	0
NAME	PECI Write Data 9							
DEFAULT	0	0	0	0	0	0	0	0

BIT	DESCRIPTION
7~0	The data would be sent to client through issuing Manual Command.

9.270 Peci Command Write Data 10 Register – Index 1Dh (Bank 2)

Attribute: Read/Write

Size: 8 bits

BIT	7	6	5	4	3	2	1	0
NAME	PECI Write Data 10							
DEFAULT	0	0	0	0	0	0	0	0



BIT	DESCRIPTION
7~0	The data would be sent to client through issuing Manual Command.

9.271 PECE Command Write Data 11 Register – Index 1Eh (Bank 2)

Attribute: Read/Write

Size: 8 bits

BIT	7	6	5	4	3	2	1	0
NAME	PECE Write Data 11							
DEFAULT	0	0	0	0	0	0	0	0

BIT	DESCRIPTION
7~0	The data would be sent to client through issuing Manual Command.

9.272 PECE Command Write Data 12 Register – Index 1Fh (Bank 2)

Attribute: Read/Write

Size: 8 bits

BIT	7	6	5	4	3	2	1	0
NAME	PECE Write Data 12							
DEFAULT	0	0	0	0	0	0	0	0

BIT	DESCRIPTION
7~0	The data would be sent to client through issuing Manual Command.

9.273 PECE Command Read Date Registers – Index 20 ~ 24h (Bank 2)

9.274 PECE Absolute Temperature value Register – Index 20h-21h (Bank 2)

[ATH_Agent [8:2] +ATL_Agent[1:0]] = Tbase + [RTH_Agent + RTL_Agent]

9.275 PECE Absolute Temperature value Register – Index 20h (Bank 2)

Attribute: Read only

Size: 8 bits

BIT	7	6	5	4	3	2	1	0
NAME	PECE Absolute Temperature Vaule[9:2]							
DEFAULT	0	0	1	0	1	0	0	0



BIT	DESCRIPTION
7~0	Absolute Temperature value of all Agent [9](Sign bit) Absolute Temperature value of all Agent [8:2](Integer bits) Absolute Temperature value of all Agent [1:0](Fraction bits)

9.276 PECE Absolute Temperature value Register – Index 21h (Bank 2)

Attribute: Read only

Size: 8 bits

BIT	7	6	5	4	3	2	1	0
NAME	Reserved						PECE Absolute Temperature Value[1:0]	
DEFAULT	0	0	0	0	0	0	0	0

BIT	DESCRIPTION
7~0	Absolute Temperature value of all Agent [9](Sign bit) Absolute Temperature value of all Agent [8:2](Integer bits) Absolute Temperature value of all Agent [1:0](Fraction bits)

9.277 PECE Command Alive Agent and Warning Flag Register – Index 24h (Bank 2)

Attribute: Read only

Size: 8 bits

BIT	7	6	5	4	3	2	1	0
NAME	Reserved		Alive Agent[1:0]		Reserved		Alert Value[1:0]	
DEFAULT	0	0	0	0	0	0	0	0

BIT	DESCRIPTION
5	Agent 31 Alive Bit 1: agent31 is able to respond to Ping() command. Agent alive 0: agent31 isn't able to respond to Ping() command. Agent is not alive
4	Agent 30 Alive Bit 1: agent30 is able to respond to Ping() command. Agent alive 0: agent30 isn't able to respond to Ping() command. Agent is not alive
1	Agent31 Alert Bit (Default value is 0) 0: Agent has valid FCS. 1: Agent has invalid FCS in the previous 3 transactions.
0	Agent30 Alert Bit (Default value is 0) 0: Agent has valid FCS. 1: Agent has invalid FCS in the previous 3 transactions.



9.278 PECI Command Read Data Register – Index 30 ~ 38h (Bank 2)

9.279 PECI Command Read Data 1 Register – Index 30h (Bank 2)

Attribute: Read only

Size: 8 bits

BIT	7	6	5	4	3	2	1	0
NAME	PECI Read Data 1							
DEFAULT	0	0	0	0	0	0	0	0

BIT	DESCRIPTION
7~0	Retrieve related data from client through issuing Manual mode. The data would be getting from client.

9.280 PECI Command Read Data 2 Register – Index 31h (Bank 2)

Attribute: Read only

Size: 8 bits

BIT	7	6	5	4	3	2	1	0
NAME	PECI Read Data 2							
DEFAULT	0	0	0	0	0	0	0	0

BIT	DESCRIPTION
7~0	Retrieve related data from client through issuing Manual mode. The data would be getting from client.

9.281 PECI Command Read Data 3 Register – Index 32h (Bank 2)

Attribute: Read only

Size: 8 bits

BIT	7	6	5	4	3	2	1	0
NAME	PECI Read Data 3							
DEFAULT	0	0	0	0	0	0	0	0

BIT	DESCRIPTION
7~0	Retrieve related data from client through issuing Manual mode. The data would be getting from client.

9.282 PECI Command Read Data 4 Register – Index 33h (Bank 2)



Attribute: Read only

Size: 8 bits

BIT	7	6	5	4	3	2	1	0
NAME	PECI Read Data 4							
DEFAULT	0	0	0	0	0	0	0	0

BIT	DESCRIPTION
7~0	Retrieve related data from client through issuing Manual mode. The data would be getting from client.

9.283 PECI Command Read Data 5 Register – Index 34h (Bank 2)

Attribute: Read only

Size: 8 bits

BIT	7	6	5	4	3	2	1	0
NAME	PECI Read Data 5							
DEFAULT	0	0	0	0	0	0	0	0

BIT	DESCRIPTION
7~0	Retrieve related data from client through issuing Manual mode. The data would be getting from client.

9.284 PECI Command Read Data 6 Register – Index 35h (Bank 2)

Attribute: Read only

Size: 8 bits

BIT	7	6	5	4	3	2	1	0
NAME	PECI Read Data 6							
DEFAULT	0	0	0	0	0	0	0	0

BIT	DESCRIPTION
7~0	Retrieve related data from client through issuing Manual mode. The data would be getting from client.

9.285 PECI Command Read Data 7 Register – Index 36h (Bank 2)

Attribute: Read only

Size: 8 bits



BIT	7	6	5	4	3	2	1	0
NAME	PECI Read Data 7							
DEFAULT	0	0	0	0	0	0	0	0

BIT	DESCRIPTION
7~0	Retrieve related data from client through issuing Manual mode. The data would be getting from client.

9.286 Peci Command Read Data 8 Register – Index 37h (Bank 2)

Attribute: Read only

Size: 8 bits

BIT	7	6	5	4	3	2	1	0
NAME	PECI Read Data 8							
DEFAULT	0	0	0	0	0	0	0	0

BIT	DESCRIPTION
7~0	Retrieve related data from client through issuing Manual mode. The data would be getting from client.

9.287 Peci Command Read Data 9 Register – Index 38h (Bank 2)

Attribute: Read only

Size: 8 bits

BIT	7	6	5	4	3	2	1	0
NAME	PECI Read Data 9							
DEFAULT	0	0	0	0	0	0	0	0

BIT	DESCRIPTION
7~0	Retrieve related data from client through issuing Manual mode. The data would be getting from client.

PECI Manual Command Address Table

Command Bank 2	Address CR 10 _{HEX}	WriteLength CR 11 _{HEX}	Read Length CR 12 _{HEX}	Command Code CR 13 _{HEX}
Ping	Addr	00	00	
GetDIB		01	08	F7



Command Bank 2	Address CR 10 _{HEX}	WriteLength CR 11 _{HEX}	Read Length CR 12 _{HEX}	Command Code CR 13 _{HEX}
GetTemp		01	02	01
PCIRd30		06	02 / 03 / 05	61
PCIWr30		08 / 09 / 0B	01	65
PCIRdLocal30		05	02 / 03 / 05	E1
PCIWrLocal30		07 / 08 / 0A	01	E5
PKGRd30		05	02 / 03 / 05	A1
PKGWr30		07 / 08 / 0A	01	A5
IAMSRd30		05	02 / 03 / 05 / 09	B1
IAMSRWr30		07 / 08 / 0A / 0E	01	B5

PECI Manual Command Read Data Table

Command	PCI Rd30	PCI Wr30	PCIRd Local30	PCIWr Local30	PKG Rd30	PKG Wr30	IAMSR Rd30	IAMSR Wr30	GetDIB	GetTemp
Command Code	61	65	E1	E5	A1	A5	B1	B5	F7	01
RdData 1 CR 30 _{HEX}	Ccode	Ccode	Ccode	Ccode	Ccode	Ccode	Ccode	Ccode	X	X
RdData 2 CR 31 _{HEX}	X	X	X	X	X	X	Data LSB_1	X	Device Info	X
RdData 3 CR 32 _{HEX}	X	X	X	X	X	X	Data LSB_2	X	Revision Number	X
RdData 4 CR 33 _{HEX}	X	X	X	X	X	X	Data LSB_3	X	Reserved 1	X
RdData 5 CR 34 _{HEX}	X	X	x	X	X	X	Data LSB_4	X	Reserved 2	X
RdData 6 CR 35 _{HEX}	Data LSB_1	X	Data LSB_1	X	Data LSB_1	X	Data LSB_5	X	Reserved 3	X
RdData 7 CR 36 _{HEX}	Data LSB_2	X	Data LSB_2	X	Data LSB_2	X	Data LSB_6	X	Reserved 4	X
RdData 8 CR 37 _{HEX}	Data LSB_3	X	Data LSB_3	X	Data LSB_3	X	Data LSB_7	X	Reserved 5	Temp_LB
RdData 9 CR 38 _{HEX}	Data MSB	X	Data MSB	X	Data MSB	X	Data MSB	X	Reserved 6	Temp_HB

Note: X mean don't care



PECI Manual Command Write Data Table

Command	PCI Rd30	PCI Wr30	PCIRd Local30	PCIWr Local30	PKG Rd30	PKG Wr30	IAMSR Rd30	IAMSR Wr30
Command Code	61	65	E1	E5	A1	A5	B1	B5
WrData 1 CR 14_{HEX}	Host ID	Host ID	Host ID	Host ID	Host ID	Host ID	Host ID	Host ID
WrData 2 CR 15_{HEX}	Addr LSB_1	Addr LSB_1	Addr LSB_1	Addr LSB_1	Index	Index	Process or ID	Process or ID
WrData 3 CR 16_{HEX}	Addr LSB_2	Addr LSB_2	Addr LSB_2	Addr LSB_2	Param LSB	Param LSB	Addr LSB	Addr LSB
WrData 4 CR 17_{HEX}	Addr LSB_3	Addr LSB_3	Addr MSB	Addr MSB	Param MSB	Param MSB	Addr MSB	Addr MSB
WrData 5 CR 18_{HEX}	Addr MSB	Addr MSB	X	Data LSB_1	X	Data LSB_1	X	Data LSB_1
WrData 6 CR 19_{HEX}	X	Data LSB_1	X	Data LSB_2	X	Data LSB_2	X	Data LSB_2
WrData 7 CR 1A_{HEX}	X	Data LSB_2	X	Data LSB_3	X	Data LSB_3	X	Data LSB_3
WrData 8 CR 1B_{HEX}	X	Data LSB_3	X	Data MSB	X	Data MSB	X	Data LSB_4
WrData 9 CR 1C_{HEX}	X	Data MSB	X	X	X	X	X	Data LSB_5
WrData10 CR 1D_{HEX}	X	X	X	X	X	X	X	Data LSB_6
WrData11 CR 1E_{HEX}	X	X	X	X	X	X	X	Data LSB_7
WrData12 CR 1F_{HEX}	X	X	X	X	X	X	X	Data MSB

Note: X mean don't care



9.288 Voltage and Temperature Read Register – Index 00h~0Fh (Bank 3)

Attribute: Read only at VSB domain

Size: 8 bits

ADDRESS 00-0F	DESCRIPTION
00h	CPUVCORE reading
01h	VIN0 reading
02h	AVCC reading
03h	3VCC reading
04h	VIN1 reading
05h	VIN2 reading
06h	RESERVED
07h	3VSB reading.
08h	VBAT reading
09h	V10 reading
0Ah	RESERVED
0Bh	RESERVED
0Ch	SYSTIN
0Dh	CPUTIN
0Eh	AUXTIN
0Fh	RESERVED

9.289 SYSTIN Temperature Sensor Offset Register – Index 11h (Bank 3)

Attribute: Read/Write

Size: 8 bits

BIT	7	6	5	4	3	2	1	0
NAME	OFFSET<7:0>							
DEFAULT	0	0	0	0	0	0	0	0

BIT	DESCRIPTION
7-0	SYSTIN Temperature Offset Value. The value in this register is added to the monitored value so that the read value will be the sum of the monitored value and this offset value.

9.290 CPUTIN Temperature Sensor Offset Register – Index 12h (Bank 3)

Attribute: Read/Write

Size: 8 bits

BIT	7	6	5	4	3	2	1	0
NAME	OFFSET<7:0>							



DEFAULT	0	0	0	0	0	0	0	0
---------	---	---	---	---	---	---	---	---

BIT	DESCRIPTION
7-0	CPUTIN Temperature Offset Value. The value in this register will be added to the monitored value so that the read value is the sum of the monitored value and this offset value.

9.291 AUXTIN Temperature Sensor Offset Register – Index13h (Bank 3)

Attribute: Read/Write

Size: 8 bits

BIT	7	6	5	4	3	2	1	0
NAME	OFFSET<7:0>							
DEFAULT	0	0	0	0	0	0	0	0

BIT	DESCRIPTION
7-0	AUXTIN Temperature Offset Value. The value in this register is added to the monitored value so that the read value is the sum of the monitored value and this offset value.

9.292 Reserved Register – Index 14h ~ 16h (Bank 3)

9.293 Configuration Register – Index 17h (Bank 3)

Attribute: Read/Write

Size: 8 bits

BIT	7	6	5	4	3	2	1	0
NAME	INITIALIZATION	RESERVED	RESERVED	RESERVED	INT_CLEAR	RESERVED	RESERVED	START
DEFAULT	0				0	0	1	1

BIT	DESCRIPTION
7	Initialization. A one restores the power-on default values to some registers. This bit clears itself since the power-on default of this bit is zero.
6	RESERVED
5	RESERVED
4	RESERVED
3	INT_Clear. A one disables the SMI# output without affecting the contents of Interrupt Status Registers. The device will stop monitoring. It will resume upon clearing of this bit.
2	Reserved.
1	RESERVED
0	Start. A one enables startup of monitoring operations. A zero puts the part in standby mode. Note: Unlike the “INT_Clear” bit, the outputs of interrupt pins will not be cleared if the user writes a zero to this location after an interrupt has occurred.



9.294 VBAT Monitor Control Register – Index 18h (Bank 3)

Attribute: Read/Write

Size: 8 bits

BIT	7	6	5	4	3	2	1	0
NAME	Reserved				DIODES3	DIODES2	DIODES1	EN_VBAT_MNT
DEFAULT	0	0	0	0	0	1	0	0

BIT	DESCRIPTION
7-4	Reserved
3	DIODES 3. Sensor type selection for AUX TIN. 1: Diode sensor. 0: Thermistor sensor. (default)
2	DIODES 2. Sensor type selection for CPUTIN. 1: Diode sensor. (default) 0: Thermistor sensor.
1	DIODES 1. Sensor type selection for SYSTIN. 1: Diode sensor. 0: Thermistor sensor. (default)
0	EN_VBAT_MNT. 1: Enable battery voltage monitor. When this bit changes from zero to one, it takes one monitor cycle time to update the VBAT reading value register. 0: Disable battery voltage monitor.

9.295 Current Mode Enable Register – Index 19h (Bank 3)

Attribute: Read/Write

Size: 8 bits

BIT	7	6	5	4	3	2	1	0
NAME	Reserved					EN_AUXTIN_CURRENT_MODE	EN_CPUTIN_CURRENT_MODE	EN_SYSTIN_CURRENT_MODE
DEFAULT	0	0	0	0	0	0	1	0

BIT	DESCRIPTION
7-3	Reserved.
2	Enable AUXTIN Current Mode. With AUXTIN is selected to Diode sensor (Bank0, Index 5Dh, Bit 3 = 1). 1: Temperature sensing of AUXTIN by Current Mode. 0: Temperature sensing of AUXTIN depends on the setting of Index 5Dh and 59h. (Default)
1	Enable CPUTIN Current Mode. With CPUTIN is selected to Diode sensor (Bank0, Index 5Dh, Bit 2 = 1).



BIT	DESCRIPTION
	1: Temperature sensing of CPUTIN by Current mode. (Default) 0: Temperature sensing of CPUTIN depends on the setting of Index 5Dh and 59h.
0	Enable SYSTIN Current Mode. With SYSTIN is selected to Diode sensor (Bank0, Index 5Dh, Bit 1 = 1). 1: Temperature sensing of SYSTIN by Current Mode. 0: Temperature sensing of SYSTIN depends on the setting of Index 5Dh and 59h. (Default)

9.296 Reserved Register – Index 1Ah ~ 8Fh (Bank 3)

9.297 PECE Agent Enable Register – Index 90h (Bank 3)

Attribute: Read/Write

Size: 8 bits

BIT	7	6	5	4	3	2	1	0
NAME	Reserved						EN_PECI1	EN_PECI0
DEFAULT	0	0	0	0	0	0	0	0

BIT	DESCRIPTION
7-2	Reserved.
1	Enable PECE Agent1 Mode.
0	Enable PECE Agent0 Mode.

9.298 Reserved Register – Index 91h ~ CFh (Bank 3)

9.299 Is<8:1> Current Register – Index D0h (Bank 3)

Attribute: Read Only

Size: 8 bits

BIT	7	6	5	4	3	2	1	0
NAME	Is<8:1>							
DEFAULT	0	0	0	0	0	0	0	0

BIT	DESCRIPTION
7-0	Is<8:1>. Current measure by current measure IC (1LSB=31.25mA)

9.300 Is<0> Current Register – Index D1h (Bank 3)

Attribute: Read Only

Size: 8 bits

BIT	7	6	5	4	3	2	1	0
-----	---	---	---	---	---	---	---	---



NAME	Reserved							Is<0>
DEFAULT	0	0	0	0	0	0	0	0

BIT	DESCRIPTION
7-1	Reserved
0	Is<0>. Current measure by current measure IC (1LSB=31.25mA)

9.301 POWER <9:2> Register – Index D2h (Bank 3)

Attribute: Read Only

Size: 8 bits

BIT	7	6	5	4	3	2	1	0
NAME	POWER <9:2>							
DEFAULT	0	0	0	0	0	0	0	0

BIT	DESCRIPTION
7-0	POWER <9:2>. Power calculate by IO (1LSB=0.25W)

9.302 POWER<1:0> Register – Index D3h (Bank 3)

Attribute: Read Only

Size: 8 bits

BIT	7	6	5	4	3	2	1	0
NAME	Reserved						POWER<1:0>	
DEFAULT	0	0	0	0	0	0	0	0

BIT	DESCRIPTION
7-1	Reserved
1:0	POWER<1:0>. Power calculate by IO (1LSB=0.25W)

9.303 VIN Register – Index D4h (Bank 3)

Attribute: Read Only

Size: 8 bits

BIT	7	6	5	4	3	2	1	0
NAME	VIN							
DEFAULT	0	0	0	0	0	0	0	0

BIT	DESCRIPTION
7-0	VIN. Power voltage given by customer. (1LSB=128mV)



9.304 Rreg Setting Register – Index D5h (Bank 3)

Attribute: Read/Write

Size: 8 bits

BIT	7	6	5	4	3	2	1	0
NAME	Rreg							
DEFAULT	0	0	0	0	0	0	0	0

BIT	DESCRIPTION
7-0	Rreg. Equivalent electric impedance in order to calculate Is. (1LSB=1m ohm)

9.305 Reg_Ratio_K and POWER_Voltage Enable Register – Index D6h (Bank 3)

Attribute: Read/Write

Size: 8 bits

BIT	7	6	5	4	3	2	1	0
NAME	Reg_Ration_K				Reserved			Power_Volt_En
DEFAULT	0	0	0	0	0	0	0	0

BIT	DESCRIPTION
7-4	Reg_Ration_K: The ration in order to make power voltage input to IO is below 2.048. Reg_Ration_K=(R1+R2)/(R1)
3-1	Reserved
0	Power_Volt_En 0:Power voltage is monitored by IO 1:Power voltage is given by customer

9.306 POWER_V Register – Index D7h (Bank 3)

Attribute: Read/Write

Size: 8 bits

BIT	7	6	5	4	3	2	1	0
NAME	POWER_V							
DEFAULT	0	0	0	0	0	0	0	0

BIT	DESCRIPTION
7-0	POWER_V: Power voltage (1LSB=128mV)

9.307 Reserved Register Index D8~FF (Bank3)

10. FLOPPY DISK CONTROLLER

10.1 FDC Functional Description

The floppy disk controller (FDC) of the NCT6102D / NCT6106D integrates all of the logic required for floppy disk control. The FDC implements a FIFO which provides better system performance in multi-master systems, and the digital data separator supports data rates up to 2 M bits/sec.

The FDC includes the following blocks: Precompensation, Data Rate Selection, Digital Data Separator, FIFO, and FDC Core. The rest of this section discusses these blocks through the following topics: FIFO, Data Separator, Write Precompensation, Perpendicular Recording mode, FDC core, FDC commands, and FDC registers.

10.1.1 FIFO (Data)

The FIFO is 16 bytes in size and has programmable threshold values. All command parameter information and disk data transfers go through the FIFO. Data transfers are governed by the RQM (Request fro Master) and DIO (Data Input / Output) bits in the Main Status Register.

The FIFO is defaulted to disabled mode after any form of reset, which maintains PC/AT hardware compatibility. The default values can be changed through the configure command. The advantage of the FIFO is that it lets the system have a larger DMA latency without causing disk errors. The following tables give several examples of the delays with the FIFO. The data are based upon the following formula:

$$\text{DELAY} = \text{THRESHOLD \#} \times (1 / \text{DATA RATE}) * 8 - 1.5 \mu\text{s}$$

Table 10-1 The Delays of the FIFO

FIFO THRESHOLD	MAXIMUM DELAY UNTIL SERVICING AT 500K BPS
	Data Rate
1 Byte	$1 \times 16 \mu\text{s} - 1.5 \mu\text{s} = 14.5 \mu\text{s}$
2 Byte	$2 \times 16 \mu\text{s} - 1.5 \mu\text{s} = 30.5 \mu\text{s}$
8 Byte	$8 \times 16 \mu\text{s} - 1.5 \mu\text{s} = 6.5 \mu\text{s}$
15 Byte	$15 \times 16 \mu\text{s} - 1.5 \mu\text{s} = 238.5 \mu\text{s}$
FIFO THRESHOLD	MAXIMUM DELAY UNTIL SERVICING AT 1M BPS
	Data Rate
1 Byte	$1 \times 8 \mu\text{s} - 1.5 \mu\text{s} = 6.5 \mu\text{s}$
2 Byte	$2 \times 8 \mu\text{s} - 1.5 \mu\text{s} = 14.5 \mu\text{s}$
8 Byte	$8 \times 8 \mu\text{s} - 1.5 \mu\text{s} = 62.5 \mu\text{s}$
15 Byte	$15 \times 8 \mu\text{s} - 1.5 \mu\text{s} = 118.5 \mu\text{s}$

At the start of a command, the FIFO is always disabled, and command parameters must be sent based upon the RQM and DIO bit settings in the Main Status Register. When the FDC enters the command execution phase, it clears the FIFO off any data to ensure that invalid data are not transferred.

An overrun or underrun terminates the current command and data transfer. Disk writes complete the current sector by generating a 00 pattern and valid CRC. Reads require the host to remove the remaining data so that the result phase may be entered.

DMA transfers are enabled by the specify command and are initiated by the FDC when the LDRQ pin is activated during a data transfer command.

10.1.2 Data Separator

The function of the data separator is to lock onto incoming serial read data. When a lock is achieved, the serial front-end logic in the chip is provided with a clock that is synchronized with the read data. The synchronized clock, called the Data Window, is used to internally sample the serial data portion of the bit cell, and the alternate state samples the clock portion. Serial-to-parallel conversion logic separates the read data into clock and data bytes.

The Digital Data Separator (DDS) has three parts: control logic, error adjustment, and speed tracking. The control logic generates RDD and RWD for every pulse input, and any data pulse input is synchronized and then adjusted immediately by error adjustment. A digital integrator keeps track of the speed changes in the input data stream.

10.1.3 Write Precompensation

The write precompensation logic minimizes bit shifts in the RDDATA stream from the disk drive. Shifting of bits is a known phenomenon in magnetic media and depends on the disk media and the floppy drive.

The FDC monitors the bit stream that is being sent to the drive. The data patterns that require precompensation are well known, so, depending on the pattern, the bit is shifted either early or late, relative to the surrounding bits.

10.1.4 Perpendicular Recording Mode

The FDC is also capable of interfacing directly to perpendicular recording floppy drives. Perpendicular recording differs from the traditional longitudinal method in that the magnetic bits are oriented vertically. This scheme packs more data bits into the same area.

FDCs with perpendicular recording drives can read standard 3.5" floppy disks and can read and write perpendicular media. Some manufacturers offer drives that can read and write standard and perpendicular media in a perpendicular media drive.

A single command puts the FDC into perpendicular mode. All other commands operate as they normally do. Perpendicular mode requires a 1 Mbps data rate for the FDC, and, at this data rate, the FIFO manages the host interface bottleneck due to the high speed of data transfer to and from the disk.

10.1.5 FDC Core

The NCT6102D / NCT6106D FDC is capable of performing twenty commands. Each command is initiated by a multi-byte transfer from the microprocessor, and the result may be a multi-byte transfer back to the microprocessor. Each command consists of three phases: command, execution, and result.

Command

The microprocessor issues all required information to the controller to perform a specific operation.

Execution

The controller performs the specified operation.

Result

After the operation is completed, status information and other housekeeping information are provided to the microprocessor.

The next section introduces each of the commands.



10.1.6 FDC Commands

Command Symbol Descriptions:

C:	Cylinder Number 0 – 256
D:	Data Pattern
DIR:	Step Direction DIR = 0: step out DIR = 1: step in
DS0:	Disk Drive Select 0
DS1:	Disk Drive Select 1
DTL:	Data Length
EC:	Enable Count
EFIFO:	Enable FIFO
EIS:	Enable Implied Seek
EOT:	End of Track
FIFOTHR:	FIFO Threshold
GAP:	Gap Length Selection
GPL:	Gap Length
H:	Head Number
HDS:	Head Number Select
HLT:	Head Load Time
HUT:	Head Unload Time
LOCK:	Lock EFIFO, FIFOTHR, and PTRTRK bits to prevent being affected by software reset
MFM:	MFM or FM Mode
MT:	Multitrack
N:	The number of data bytes written in a sector
NCN:	New Cylinder Number
ND:	Non-DMA Mode
OW:	Overwritten
PCN:	Present Cylinder Number
POLL:	Polling Disable
PRETRK:	Precompensation Start Track Number
R:	Record
RCN:	Relative Cylinder Number
R/W:	Read/Write
SC:	Sectors per Cylinder
SK:	Skip deleted data address mark
SRT:	Step Rate Time
ST0:	Status Register 0
ST1:	Status Register 1
ST2:	Status Register 2
ST3:	Status Register 3
WG:	Write gate alters timing of WE

(1) Read Data

PHASE	R/W	D7	D6	D5	D4	D3	D2	D1	D0	REMARKS
Command	W	MT	MFM	SK	0	0	1	1	0	Command codes



PHASE	R/W	D7	D6	D5	D4	D3	D2	D1	D0	REMARKS
	W	0	0	0	0	0	HDS	DS1	DS0	Sector ID information prior to command execution
	W	----- C -----								
	W	----- H -----								
	W	----- R -----								
	W	----- N -----								
	W	----- EOT -----								
	W	----- GPL -----								
	W	----- DTL -----								
Execution										Data transfer between the FDD and system
Result	R	----- ST0 -----								Status information after command execution
	R	----- ST1 -----								
	R	----- ST2 -----								
	R	----- C -----								Sector ID information after command execution
	R	----- H -----								
	R	----- R -----								
	R	----- N -----								

(2) Read Deleted Data

PHASE	R/W	D7	D6	D5	D4	D3	D2	D1	D0	REMARKS	
Command	W	MT	MFM	SK	0	1	1	0	0	Command codes	
	W	0	0	0	0	0	HDS	DS1	DS0		
	W	----- C -----									Sector ID information prior to command execution
	W	----- H -----									
	W	----- R -----									
	W	----- N -----									
	W	----- EOT -----									
	W	----- GPL -----									
W	----- DTL -----										
Execution										Data transfer between the FDD and system	
Result	R	----- ST0 -----								Status information after command execution	
	R	----- ST1 -----									
	R	----- ST2 -----									
	R	----- C -----								Sector ID information after command execution	
	R	----- H -----									
	R	----- R -----									
	R	----- N -----									



(3) Read A Track

PHASE	R/W	D7	D6	D5	D4	D3	D2	D1	D0	REMARKS
Command	W	0	MFM	0	0	0	0	1	0	Command codes Sector ID information prior to command execution
	W	0	0	0	0	0	HDS	DS1	DS0	
	W	----- C -----								
	W	----- H -----								
	W	----- R -----								
	W	----- N -----								
	W	----- EOT -----								
	W	----- GPL -----								
	W	----- DTL -----								
Execution										Data transfer between the FDD and system; FDD reads contents of all cylinders from index hole to EOT
Result	R	----- ST0 -----								Status information after command execution
	R	----- ST1 -----								
	R	----- ST2 -----								
	R	----- C -----								Sector ID information after command execution
	R	----- H -----								
	R	----- R -----								
	R	----- N -----								

(4) Read ID

PHASE	R/W	D7	D6	D5	D4	D3	D2	D1	D0	REMARKS
Command	W	0	MFM	0	0	1	0	1	0	Command codes
	W	0	0	0	0	0	HDS	DS1	DS0	
Execution										The first correct ID information on the cylinder is stored in the Data Register
Result	R	----- ST0 -----								Status information after command execution
	R	----- ST1 -----								
	R	----- ST2 -----								
	R	----- C -----								Disk status after the command has been completed
	R	----- H -----								
	R	----- R -----								
	R	----- N -----								



(5) Verify

PHASE	R/W	D7	D6	D5	D4	D3	D2	D1	D0	REMARKS	
Command	W	MT	MFM	SK	1	0	1	1	0	Command codes	
	W	EC	0	0	0	0	HDS	DS1	DS0		
	W	----- C -----									Sector ID information prior to command execution
	W	----- H -----									
	W	----- R -----									
	W	----- N -----									
	W	----- EOT -----									
	W	----- GPL -----									
W	----- DTL/SC -----										
Execution										No data transfer takes place	
Result	R	----- ST0 -----								Status information after command execution	
	R	----- ST1 -----									
	R	----- ST2 -----									
	R	----- C -----								Sector ID information after command execution	
	R	----- H -----									
	R	----- R -----									
	R	----- N -----									

(6) Version

PHASE	R/W	D7	D6	D5	D4	D3	D2	D1	D0	REMARKS
Command	W	0	0	0	1	0	0	0	0	Command code
Result	R	1	0	0	1	0	0	0	0	Enhanced controller

(7) Write Data

PHASE	R/W	D7	D6	D5	D4	D3	D2	D1	D0	REMARKS	
Command	W	MT	MFM	0	0	0	1	0	1	Command codes	
	W	0	0	0	0	0	HDS	DS1	DS0		
	W	----- C -----									Sector ID information prior to Command execution
	W	----- H -----									
	W	----- R -----									
	W	----- N -----									
	W	----- EOT -----									
	W	----- GPL -----									
	W	----- DTL -----									
Execution										Data transfer between the FDD and the system	



PHASE	R/W	D7	D6	D5	D4	D3	D2	D1	D0	REMARKS
Result	R	----- ST0 -----								Status information after Command execution
	R	----- ST1 -----								
	R	----- ST2 -----								
	R	----- C -----								Sector ID information after Command execution
	R	----- H -----								
	R	----- R -----								
	R	----- N -----								

(8) Write Deleted Data

PHASE	R/W	D7	D6	D5	D4	D3	D2	D1	D0	REMARKS	
Command	W	MT	MFM	0	0	1	0	0	1	Command codes	
	W	0	0	0	0	0	HDS	DS1	DS0		
	W	----- C -----									Sector ID information prior to command execution
	W	----- H -----									
	W	----- R -----									
	W	----- N -----									
	W	----- EOT -----									
	W	----- GPL -----									
	W	----- DTL -----									
Execution										Data transfer between the FDD and the system	
Result	R	----- ST0 -----								Status information after command execution	
	R	----- ST1 -----									
	R	----- ST2 -----									
	R	----- C -----								Sector ID information after command execution	
	R	----- H -----									
	R	----- R -----									
	R	----- N -----									

(9) Format A Track

PHASE	R/W	D7	D6	D5	D4	D3	D2	D1	D0	REMARKS	
Command	W	0	MFM	0	0	1	1	0	1	Command codes	
	W	0	0	0	0	0	HDS	DS1	DS0		
	W	----- N -----									Bytes per Sector
	W	----- SC -----									Sectors per Cylinder
	W	----- GPL -----									Gap 3
	W	----- D -----									Filler Byte



PHASE	R/W	D7	D6	D5	D4	D3	D2	D1	D0	REMARKS
Execution for Each Sector: (Repeat)	W	----- C -----								Input Sector Parameters
	W	----- H -----								
	W	----- R -----								
	W	----- N -----								
Result	R	----- ST0 -----								Status information after command execution
	R	----- ST1 -----								
	R	----- ST2 -----								
	R	----- Undefined -----								
	R	----- Undefined -----								
	R	----- Undefined -----								
	R	----- Undefined -----								

(10) Recalibrate

PHASE	R/W	D7	D6	D5	D4	D3	D2	D1	D0	REMARKS
Command	W	0	0	0	0	0	1	1	1	Command codes
	W	0	0	0	0	0	0	DS1	DS0	
Execution										Head retracted to Track 0 Interrupt

(11) Sense Interrupt Status

PHASE	R/W	D7	D6	D5	D4	D3	D2	D1	D0	REMARKS
Command	W	0	0	0	0	1	0	0	0	Command code
Result	R	----- ST0 -----								Status information at the end of each seek operation
	R	----- PCN -----								

(12) Specify

PHASE	R/W	D7	D6	D5	D4	D3	D2	D1	D0	REMARKS
Command	W	0	0	0	0	0	0	1	1	Command codes
	W	-----SRT----- -----HUT-----								
	W	-----HLT----- ND								

(13) Seek

PHASE	R/W	D7	D6	D5	D4	D3	D2	D1	D0	REMARKS
Command	W	0	0	0	0	1	1	1	1	Command codes
	W	0	0	0	0	0	HDS	DS1	DS0	
	W	----- NCN -----								
Execution	R									Head positioned over proper cylinder on the diskette



(14) Configure

PHASE	R/W	D7	D6	D5	D4	D3	D2	D1	D0	REMARKS	
Command	W	0	0	0	1	0	0	1	1	Configure information	
	W	0	0	0	0	0	0	0	0		
	W	0 EIS EFIFO POLL ----- FIFOTHR ----									
	W	-----PRETRK -----									
Execution										Internal registers written	

(15) Relative Seek

PHASE	R/W	D7	D6	D5	D4	D3	D2	D1	D0	REMARKS
Command	W	1	DIR	0	0	1	1	1	1	Command codes
	W	0	0	0	0	0	HDS	DS1	DS0	
	W	----- RCN -----								

(16) Dumpreg

PHASE	R/W	D7	D6	D5	D4	D3	D2	D1	D0	REMARKS
Command	W	0	0	0	0	1	1	1	0	Registers placed in FIFO
Result	R	----- PCN-Drive 0-----								
	R	----- PCN-Drive 1 -----								
	R	----- PCN-Drive 2-----								
	R	----- PCN-Drive 3 -----								
	R	-----SRT ----- ----- HUT -----								
	R	----- HLT ----- ND								
	R	----- SC/EOT -----								
	R	LOCK 0 D3 D2 D1 D0 GAP WG								
	R	0 EIS EFIFO POLL ----- FIFOTHR -----								
	R	-----PRETRK -----								

(17) Perpendicular Mode

PHASE	R/W	D7	D6	D5	D4	D3	D2	D1	D0	REMARKS
Command	W	0	0	0	1	0	0	1	0	Command Code
	W	OW	0	D3	D2	D1	D0	GAP	WG	

(18) Lock

PHASE	R/W	D7	D6	D5	D4	D3	D2	D1	D0	REMARKS
Command	W	LOCK	0	0	1	0	1	0	0	Command Code
Result	R	0	0	0	LOCK	0	0	0	0	

(19) Sense Drive Status

PHASE	R/W	D7	D6	D5	D4	D3	D2	D1	D0	REMARKS
Command	W	0	0	0	0	0	1	0	0	Command Code



PHASE	R/W	D7	D6	D5	D4	D3	D2	D1	D0	REMARKS
	W	0	0	0	0	0	HDS	DS1	DS0	
Result	R	----- ST3 -----								Status information about the disk drive

(20) Invalid

PHASE	R/W	D7	D6	D5	D4	D3	D2	D1	D0	REMARKS
Command	W	----- Invalid Codes -----								Invalid codes (no operation-FDC goes to standby state)
Result	R	----- ST0 -----								ST0 = 80h



10.2 Register Descriptions

There are several status, data, and control registers in the NCT6102D / NCT6106D. These registers are defined below, and the rest of this section provides more details about each one of them.

Table 10-2 FDC Registers

ADDRESS OFFSET	REGISTER	
	READ	WRITE
base address + 0	SA REGISTER	
base address + 1	SB REGISTER	
base address + 2		DO REGISTER
base address + 3	TD REGISTER	TD REGISTER
base address + 4	MS REGISTER	DR REGISTER
base address + 5	DT (FIFO) REGISTER	DT (FIFO) REGISTER
base address + 7	DI REGISTER	CC REGISTER

10.2.1 Status Register A (SA Register) (Read base address + 0)

Along with the SB register, the SA register is used to monitor several disk-interface pins in PS/2 and Model 30 modes. In PS/2 mode, the bit definitions for this register are as follows:

BIT	7	6	5	4	3	2	1	0
NAME	INIT PENDING	DRV 2#	STEP	TRAK0#	HEAD	INDEX#	WP#	DIR
DEFAULT	0	0	NA	1	NA	1	1	NA

BIT	DESCRIPTION
7	INIT PENDING. Indicates the value of the floppy disk interrupt output.
6	DRV2#. 0: A second drive has been installed. 1: A second drive has not been installed.
5	STEP. Indicates the complement of the STEP# output.
4	TRAK0#. Indicates the value of the TRAK# input.
3	HEAD. Indicates the complement of the HEAD# output. 0: Side 0. 1: Side 1.
2	INDEX#. Indicates the value of the INDEX# output.
1	WP#. 0: The disk is write-protected. 1: The disk is not write-protected.
0	DIR. Indicates the direction of head movement. 0: Outward direction. 1: Inward direction.

In PS/2 Model 30 mode, the bit definitions for this register are as follows:



BIT	7	6	5	4	3	2	1	0
NAME	INIT PENDING	DRQ	STEP F/F	TRAK0	HEAD#	INDEX	WP	DIR#
DEFAULT	0	0	NA	0	NA	0	0	NA

BIT	DESCRIPTION
7	INIT PENDING. Indicates the value of the floppy disk interrupt output.
6	DRQ. Indicates the value of the DRQ output pin.
5	SETP F/F. indicates the complement of latched STEP# output.
4	TRAK0. Indicates the complement of the TRAK0# input.
3	HEAD#. Indicates the value of the HEAD# output. 0: Side 1. 1: Side 0.
2	INDEX. Indicates the complement of the INDEX# output.
1	WP. 0: The disk is not write-protected. 1: The disk is write-protected.
0	DIR#. Indicates the direction of the head movement. 0: Inward direction. 1: Outward direction.

10.2.2 Status Register B (SB Register) (Read base address + 1)

Along with the SA register, the SB register is used to monitor several disk interface pins in PS/2 and Model 30 modes. In PS/2 mode, the bit definitions for this register are as follows:

BIT	7	6	5	4	3	2	1	0
NAME	Reserved		Drive SEL0	WDTA Toggle	RDTA Toggle	WE	Reserved	MOT EN A
DEFAULT	1	1	0	0	0	0	0	0

BIT	DESCRIPTION
7-6	Reserved.
5	Drive SEL0. Indicates the status of the DO Register, bit 0 (drive-select bit 0).
4	WDTA Toggle. Changes state on every rising edge of the WD# output pin.
3	RDTA Toggle. Changes state on every rising edge of the RDATA# output pin.
2	WE. Indicates the complement of the WE# output pin.
1	Reserved.
0	MOT EN A. Indicates the complement of the MOA# output pin.

In PS/2 Model 30 mode, the bit definitions for this register are as follows:

BIT	7	6	5	4	3	2	1	0
NAME	RESERVED		DSA#	WD F/F	RDATA	WE F/F	DSD#	DSC#



					F/F			
DEFAULT	0	1	1	0	0	0	1	1

BIT	DESCRIPTION
7-6	Reserved.
5	DSA#. This bit indicates the status of the DSA# output pin.
4	WD F/F. Indicates the complement of the WD# output pin, which is latched on every rising edge of the WD# output pin.
3	RDATA F/F. Indicates the complement of the latched RDATA# output pin.
2	WE F/F. Indicates the complement of the latched WE# output pin.
1	DSD#. 0: Drive D has been selected. 1: Drive D has not been selected.
0	Reserved.

10.2.3 Digital Output Register (DO Register) (Write base address + 2)

The Digital Output Register is a write-only register that controls drive motors, drive selection, DRQ/IRQ enable, and FDC reset. All the bits in this register are cleared by the MR pin. The bit definitions are as follows:

BIT	7	6	5	4	3	2	1	0
NAME	RESERVED			MOTOR ENABLE A	DMA&INT ENABLE	FDC RESET	DRIVE SELECT	
DEFAULT	0	0	0	0	0	0	0	0

BIT	DESCRIPTION
7-5	Reserved.
4	MOTOR ENABLE A. A logical 1 enables Motor A.
3	DMA & INT ENABLE. A logical 1 enables DRQ/IRQ.
2	FDC RESET. Floppy Disk Controller Reset. A logical 0 resets the FDC.
1-0	DRIVE SELECT. Bits 1 0 0 0: Select Drive A. 0 1: Select Drive B. 1 0: Select Drive C. 1 1: Select Drive D.

10.2.4 Tape Drive Register (TD Register) (Read base address + 3)

This register is used to assign a particular drive number to the tape drive support mode of the data separator. This register also holds the media ID, drive type, and floppy boot drive information for the floppy disk drive.

In normal floppy mode, this register only has bits 0 and 1, and the bit definitions are as follows:



BIT	7	6	5	4	3	2	1	0
NAME	RESERVED						Tape sel 1	Tape sel 0
DEFAULT	NA	NA	NA	NA	NA	NA	0	0

BIT	DESCRIPTION
7-2	RESERVED.
1	Tape sel 1.
0	Tape sel 0.

If the three-mode FDD function is enabled (EN3MODE = 1 in LD0 CRF0, Bit 0), the bit definitions are as follows:

BIT	7	6	5	4	3	2	1	0
NAME	Media ID1	Media ID0	Drive Type ID1	Drive Type ID0	Floppy Boot Drive 1	Floppy Boot Drive 0	Tape Sel 1	Tape Sel 0
DEFAULT	0	0	1	1	0	0	0	0

BIT	DESCRIPTION
7	Media ID1. Read only. Reflects the value of LD0, CRF1, bit 5.
6	Media ID0. Read only. Reflects the value of LD0, CRF1, bit 4.
5	Drive Type ID1.
4	Drive Type ID0.
3	Floppy Boot Drive 1. Reflects the value of LD0, CRF1, bit 7.
2	Floppy Boot Drive 0. Reflects the value of LD0, CRF1, bit 6.
1	Tape Sel 1.
0	Tape Sel 0.

Reflect the bit in LD0, CR[F2h]. Which bit is reflected depends on the last drive selected in the PO register.

Assign a logical drive number to the tape drive. Drive 0 is not available as a tape drive and is reserved for the floppy disk boot drive.

TAPE SEL 1	TAPE SEL 0	DRIVE SELECTED
0	0	None
0	1	1
1	0	2
1	1	3

10.2.5 Main Status Register (MS Register) (Read base address + 4)

The Main Status Register is used to control the flow of data between the microprocessor and the controller. The bit definitions for this register are as follows:

BIT	7	6	5	4	3	2	1	0
NAME	RQM	DIO	Non-DMA	FDC Busy	RESERVED			FDD 0



			mode					Busy
DEFAULT	0	NA	NA	NA	NA	NA	NA	NA

BIT	DESCRIPTION
7	Request for Master (RQM). A high on this bit indicates Data Register is ready to send or receive data to or from the processor.
6	DATA INPUT/OUTPUT (DIO). If DIO = HIGH, then the transfer is from Data Register to the processor. If DIO = LOW, the transfer is from processor to Data Register.
5	Non-DMA mode. The FDC is in the non-DMA mode, this bit is set only during the execution phase in non-DMA mode.
4	FDC Busy (CB). A read or write command is in the process when CB = HIGH.
3-1	Reserved.
0	FDD 0 Busy. (D0B = 1) FDD number 0 is in the SEEK mode.

10.2.6 Data Rate Register (DR Register) (Write base address + 4)

The Data Rate Register is used to set the transfer rate and write precompensation. However, in PC-AT and PS/2 Model 30 and PS/2 modes, the data rate is controlled by the CC register, not by the DR register. As a result, the real data rate is determined by the most recent write to either the DR or CC register. The bit definitions for this register are as follows:

BIT	7	6	5	4	3	2	1	0
NAME	S/W RESET	POWER DOWN	RESERVED	PRECOMP2	PRECOMP1	PRECOMP0	DRATE1	DRATE0
DEFAULT	0	0	0	0	0	0	1	0

BIT	DESCRIPTION
7	S/W RESET. The software reset bit.
6	POWER DOWN. 0: FDC in normal mode. 1: FDC in power-down mode.
5	RESERVED.
4	PRECOMP 2.
3	PRECOMP 1.
2	PRECOMP 0.
1	DRATE 1. Select the data rate of the FDC and reduced write-current control. Bits 1 0 0 0: 500 KB/S (MFM), 250 KB/S (FM),



BIT	DESCRIPTION	
0	DRATE 0.	RWC# = 1 0 1: 300 KB/S (MFM), 150 KB/S (FM), RWC# = 0 1 0: 250 KB/S (MFM), 125 KB/S (FM), RWC# = 0 1 1: 1 MB/S (MFM), Illegal (FM), RWC# = 1

The 2 MB/S data rate for the tape drive is only supported by setting DRATE1 and DRATE0 to 01, as well as setting DRT1 and DRT0 (CRF4 and CRF5 for logical device 0) to 10. Please see the functional description of CRF4 or CRF5 and the data rate table for individual data-rate settings.

PRECOMP	PRECOMPENSATION DELAY	
2 1 0	250K – 1 Mbps	2 Mbps Tape drive
0 0 0	Default Delays	Default Delays
0 0 1	41.67 ns	20.8 ns
0 1 0	83.34 ns	41.17 ns
0 1 1	125.00 ns	62.5ns
1 0 0	166.67 ns	83.3 ns
1 0 1	208.33 ns	104.2 ns
1 1 0	250.00 ns	125.00 ns
1 1 1	0.00 ns (disabled)	0.00 ns (disabled)

DATA RATE	DEFAULT PRECOMPENSATION DELAYS
250 KB/S	125 ns
300 KB/S	125 ns
500 KB/S	125 ns
1 MB/S	41.67ns
2 MB/S	20.8 ns

10.2.7 FIFO Register (R/W base address + 5)

The FIFO register consists of four status registers in a stack, and only one register is presented to the data bus at a time. The FIFO register stores data, commands, and parameters, and it provides disk-drive status information. In addition, data bytes pass through the data register to program or obtain results after a command. In the NCT6102D / NCT6106D, this register is disabled after reset. The FIFO can enable it and change its values through the CONFIGURE command.

BIT	7	6	5	4	3	2	1	0
NAME	IC		SE	EC	NR	HD	US1, US0 Drive Select	

Status Register 0 (ST0)

BIT	DESCRIPTION
7-6	IC (Interrupt Code). Bits 7 6



BIT	DESCRIPTION
	0 0: Normal termination of the command. 0 1: Abnormal termination of the command. 1 0: Invalid command issue. 1 1: Abnormal termination because the ready signal from FDD changed state during command execution.
5	SE (Seek End). 1: Seek end. 0: Seek error.
4	EC (Equipment Check). 1: When a fault signal is received from the FDD or the track. Signal fails to occur after 77 step pulses. 0: No error.
3	NR (Not Ready). 1: Drive is not ready. 0: Drive is ready.
2	HD Head Address. (The current head address) 1: Head selected. 0: Head selected.
1-0	US 1, US0 Drive Select. Bits 1 0 0 0: Drive A selected. 0 1: Drive B selected. 1 0: Drive C selected. 1 1: Drive D selected.

Status Register 1 (ST1)

BIT	7	6	5	4	3	2	1	0
NAME	EN	Reserved	OE	OR	Reserved	ND	NW	MAM

BIT	DESCRIPTION
7	EN (End of Track). 1 will be written to this bit if the FDC tries to access a sector beyond the final sector or a cylinder.
6	Reserved. This bit is always 0.
5	DE (Data Error). 1 will be written to this bit if the FDC detects a CRC error in either the ID field or the data field.
4	OR (Over Run). 1 will be written to this bit if the FDC is not served by the host system within a certain time interval during data transfer.
3	Reserved. This bit is always 0.
2	ND (No Data). 1 will be written to this bit if the specified sector cannot be found during execution of a read, write or verify data.
1	NW (Not Writable). 1 will be written to this bit if a write protect signal is detected from the diskette drive during execution of write data.
0	MAM (Missing Address Mark). 1 will be written to this bit if the FDC cannot detect the data address mark or the data address mark has been deleted.



Status Register 2 (ST2)

BIT	7	6	5	4	3	2	1	0
NAME	NOT USED	CM	DD	WC	SH	SN	BC	MD

BIT	DESCRIPTION
7	Not used. This bit is always 0.
6	CM (Control Mark). 1: During execution of the read data or scan command. 0: No error.
5	DD (Data error in the Data field). 1: If the FDC detects a CRC error in the data field. 0: No error.
4	WC (Wrong Cylinder). 1: Indicates wrong cylinder.
3	SH (Scan Equal Hit). 1: During execution of the Scan command, if the equal condition is satisfied. 0: No error.
2	SN (Scan Not Satisfied). 1: During execution of the Scan command. 0: No error.
1	BC (Bad Cylinder). 1: Bad Cylinder. 0: No error.
0	MD (Missing Address Mark in Data Field). 1: If FDC cannot find a data address mark (or the address mark has been deleted) when reading data from the media. 0: No error.

Status Register 3 (ST3)

BIT	7	6	5	4	3	2	1	0
NAME	FT	WP	RY	T0	TS	HD	US1	US0

BIT	DESCRIPTION
7	FT. Fault.
6	WP. Write protected.
5	RY. Ready.
4	T0. Track 0.
3	TS. Two-side.
2	HD. Head Address.
1	US1. Unit Select 1.
0	US0. Unit Select 0.



10.2.8 Digital Input Register (DI Register) (Read base address + 7)

The Digital Input Register is an 8-bit, read-only register used for diagnostic purposes. In PC/XT or PC/AT mode, only bit 7 is checked by the BIOS. When the register is read, bit 7 shows the complement of DSKCHG#, while the other bits remain in tri-state. The bit definitions are as follows:

BIT	7	6	5	4	3	2	1	0	
NAME	DSKCHG	RESERVED							
DEFAULT	0	NA	NA	NA	NA	NA	NA	NA	

BIT	DESCRIPTION
7	DSKCHG.
6-0	RESERVED. Reserved for the hard disk controller. During a read of this register, these bits are in tri-state.

In PS/2 mode, the bit definitions are as follows:

BIT	7	6	5	4	3	2	1	0	
NAME	DSKCHG	RESERVED				DRATE1	DRATE0	HIGH DENS#	
DEFAULT	0	1	1	1	1	1	0	1	

BIT	DESCRIPTION
7	DSKCHG. Indicates the complement of the DSKCHG# input.
6-3	RESERVED. Always 1 during a read.
2	DRATE 1.
1	DRATE 0.
0	HIGHDENS#. 0: 500 KB/S or 1 MB/S data rate (high-density FDD). 1: 250 KB/S or 300 KB/S data rate.

In PS/2 Model 30 mode, the bit definitions are as follows:

BIT	7	6	5	4	3	2	1	0
NAME	DSKCHG#	RESERVED			DMAEN	NOPREC	DRATE1	DRATE0
DEFAULT	1	0	0	0	0	0	1	0

BIT	DESCRIPTION
7	DSKCHG. Indicates the status of the DSKCHG# input.
6-4	RESERVED. Always 0 during a read.
3	DMAEN. Indicates the value of DO register, bit 3.



2	NOPREC. Indicates the value of the NOPREC bit in the CC REGISTER.	
1	DRATE 1.	Select the data rate of the FDC. See DR register bits 1 and 0 (Data Rate Register (DR Register) (Write base address +4)) for how the settings correspond to individual data rates.
0	DRATE 0.	

10.2.9 Configuration Control Register (CC Register) (Write base address + 7)

This register is used to control the data rate. In PC/AT and PS/2 mode, the bit definitions are as follows:

BIT	7	6	5	4	3	2	1	0
NAME	RESERVED						DRATE1	DRATE0
DEFAULT	NA	NA	NA	NAN	NA	NA	1	0

BIT	DESCRIPTION	
7-2	RESERVED. Should be set to 0.	
1	DRATE 1.	Select the data rate of the FDC. See DR register bits 1 and 0 (Data Rate Register (DR Register) (Write base address +4)) for how the settings correspond to individual data rates.
0	DRATE 0.	

In the PS/2 Model 30 mode, the bit definitions are as follows:

BIT	7	6	5	4	3	2	1	0
NAME	RESERVED					NOPREC	DRATE1	DRATE0
DEFAULT	NA	NA	NA	NA	NA	0	1	0

BIT	DESCRIPTION	
7-3	RESERVED. Should be set to 0.	
2	NOPREC. Disables the precompensation function. This bit can be set by the software.	
1	DRATE1.	Select the data rate of the FDC. See DR register bits 1 and 0 (Data Rate Register (DR Register) (Write base address + 4)) for how the settings correspond to individual data rates.
0	DRATE0.	



11. UART PORT

NCT6102D supports 2 UART – UART A and UART B.

NCT6106D supports 6 UART – UART A, UART B, UART C, UART D, UART E and UART F.

11.1 UART Control Register (UCR) (Read/Write)

The UART Control Register defines and controls the protocol for asynchronous data communications, including data length, stop bit, parity, and baud rate selection.

BIT	7	6	5	4	3	2	1	0
NAME	BDLAB	SSE	PBFE	EPE	PBE	MSBE	DLS1	DLS0
DEFAULT	0	0	0	0	0	0	0	0

BIT	DESCRIPTION
7	BDLAB (Baud Rate Divisor Latch Access Bit). When this bit is set to logic 1, designers can access the divisor (in 16-bit binary format) from the divisor latches of the baud-rate generator during a read or write operation. When this bit is set to logic 0, the Receiver Buffer Register, the Transmitter Buffer Register, and the Interrupt Control Register can be accessed.
6	SSE (Set Silence Enable). A logic 1 forces the Serial Output (SOUT) to a silent state (a logical 0). Only IRTX is affected by this bit; the transmitter is not affected.
5	PBFE (Parity Bit Fixed Enable). When PBE and PBFE of UCR are both set to logic 1, (1) if EPE is logic 1, the parity bit is logical 0 when transmitting and checking; (2) if EPE is logic 0, the parity bit is logical 1 when transmitting and checking.
4	EPE (Even Parity Enable). When PBE is set to logic 1, this bit counts the number of logic 1's in the data word bits and determines the parity bit. When this bit is set to logic 1, the parity bit is set to logic 1 if an even number of logic 1's are sent or checked. When the bit is set to logic 0, the parity bit is logic 1, if an odd number of logic 1's are sent or checked.
3	PBE (Parity Bit Enable). When this bit is set to logic 1, the transmitter inserts a stop bit between the last data bit and the stop bit of the SOUT, and the receiver checks the parity bit in the same position.
2	MSBE (Multiple Stop Bit Enable). Defines the number of stop bits in each serial character that is transmitted or received. (1) If MSBE is set to logic 0, one stop bit is sent and checked. (2) If MSBE is set to logic 1 and the data length is 5 bits, one-and-a-half stop bits are sent and checked. (3) If MSBE is set to logic 1 and the data length is 6, 7, or 8 bits, two stop bits are sent and checked.
1	DLS1 (Data Length Select Bit 1). Defines the number of data bits that are sent or checked in each serial character.
0	DLS0 (Data Length Select Bit 0). Defines the number of data bits that are sent or checked in each serial character.

DLS1	DLS0	DATA LENGTH
0	0	5 bits



DLS1	DLS0	DATA LENGTH
0	1	6 bits
1	0	7 bits
1	1	8 bits

The following table identifies the remaining UART registers. Each one is described separately in the following sections.

Table 11-1 Register Summary for UART

Register Address Base		Bit Number								
		0	1	2	3	4	5	6	7	
+ 0 BDLAB = 0	Receiver Buffer Register (Read Only)	RBR	RX Data Bit 0	RX Data Bit 1	RX Data Bit 2	RX Data Bit 3	RX Data Bit 4	RX Data Bit 5	RX Data Bit 6	RX Data Bit 7
+ 0 BDLAB = 0	Transmitter Buffer Register (Write Only)	TBR	TX Data Bit 0	TX Data Bit 1	TX Data Bit 2	TX Data Bit 3	TX Data Bit 4	TX Data Bit 5	TX Data Bit 6	TX Data Bit 7
+ 1 BDLAB = 0	Interrupt Control Register	ICR	RBR Data Ready Interrupt Enable (ERDRI)	TBR Empty Interrupt Enable (ETBREI)	USR Interrupt Enable (EUSRI)	HSR Interrupt Enable (EHSRI)	0	0	0	0
+ 2	Interrupt Status Register (Read Only)	ISR	"0" if Interrupt Pending	Interrupt Status Bit (0)	Interrupt Status Bit (1)	Interrupt Status Bit (2)**	0	0	FIFOs Enabled **	FIFOs Enabled **
+ 2	UART FIFO Control Register (Write Only)	UFR	FIFO Enable	RCVR FIFO Reset	XMIT FIFO Reset	DMA Mode Select	Reserved	Reversed	RX Interrupt Active Level (LSB)	RX Interrupt Active Level (MSB)
+ 3	UART Control Register	UCR	Data Length Select Bit 0 (DLS0)	Data Length Select Bit 1 (DLS1)	Multiple Stop Bits Enable (MSBE)	Parity Bit Enable (PBE)	Even Parity Enable (EPE)	Parity Bit Fixed Enable (PBE)	Set Silence Enable (SSE)	Baudrate Divisor Latch Access Bit (BDLAB)
+ 4	Handshake Control Register	HCR	Data Terminal Ready (DTR)	Request to Send (RTS)	Loopback RI Input	IRQ Enable	Internal Loopback Enable	0	0	0
+ 5	UART Status Register	USR	RBR Data Ready (RDR)	Overrun Error (OER)	Parity Bit Error (PBER)	No Stop Bit Error (NSER)	Silent Byte Detected (SBD)	TBR Empty (TBRE)	TSR Empty (TSRE)	RX FIFO Error Indication (RFEI) **
+ 6	Handshake Status Register	HSR	CTS Toggling (TCTS)	DSR Toggling (TDSR)	RI Falling Edge (FERI)	DCD Toggling (TDCD)	Clear to Send (CTS)	Data Set Ready (DSR)	Ring Indicator (RI)	Data Carrier Detect (DCD)
+ 7	User Defined Register	UDR	Bit 0	Bit 1	Bit 2	Bit 3	Bit 4	Bit 5	Bit 6	Bit 7
+ 0 BDLAB = 1	Baudrate Divisor Latch Low	BLL	Bit 0	Bit 1	Bit 2	Bit 3	Bit 4	Bit 5	Bit 6	Bit 7
+ 1 BDLAB = 1	Baudrate Divisor Latch High	BHL	Bit 8	Bit 9	Bit 10	Bit 11	Bit 12	Bit 13	Bit 14	Bit 15

*: Bit 0 is the least significant bit. The least significant bit is the first bit serially transmitted or received.

** : These bits are always 0 in 16450 Mode.

11.2 UART Status Register (USR) (Read/Write)

This 8-bit register provides information about the status of data transfer during communication.

BIT	7	6	5	4	3	2	1	0
NAME	RF EI	TSRE	TBRE	SBD	NSER	PBER	OER	RDR
DEFAULT	0	1	1	0	0	0	0	0

BIT	DESCRIPTION
7	RF EI (RX FIFO Error Indication). In 16450 mode, this bit is always set to logical 0. In 16550 mode, this bit is set to logical 1 when there is at least one parity-bit error and no stop0bit error or silent-byte detected in the FIFO. In 16550 mode, this bit is cleared to logical 0 by reading from the USR if there are no remaining errors left in the FIFO.
6	TSRE (Transmitter Shift Register Empty). In 16450 mode, this bit is set to logical 1 when TBR and TSR are both empty. In 16550 mode, it is set to logical 1 when the transmit FIFO and TSR are both empty. Otherwise, this bit is set to logical 0.
5	TBRE (Transmitter Buffer Register Empty). In 16450 mode, when a data character is transferred from TBR to TSR, this bit is set to logical 1. If ETREI of ICR is high, and interrupt is generated to notify the CPU to write next data. In 16550 mode, this bit is set to logical 1 when the transmit FIFO is empty. It is set to logical 0 when the CPU writes data into TBR or the FIFO.
4	SBD (Silent Byte Detected). This bit is set to logical 1 to indicate that received data are kept in silent state for the time it takes to receive a full word, which includes the start bit, data bits, parity bit, and stop bits. In 16550 mode, it indicates the same condition for the data on the top of the FIFO. When the CPU reads USR, it sets this bit to logical 0.
3	NSER (No Stop Bit Error). This bit is set to logical 1 to indicate that the received data have no stop bit. In 16550 mode, it indicates the same condition for the data on the top of the FIFO. When the CPU reads USR, it sets this bit to logical 0.
2	PBER (Parity Bit Error). This bit is set to logical 1 to indicate that the received data has the wrong parity bit. In 16550 mode, it indicates the same condition for the data on the top of the FIFO. When the CPU reads USR, it sets this bit to logical 0.
1	OER (Overrun Error). This bit is set to logical 1 to indicate that the received data have been overwritten by the next received data before they were read by the CPU. In 16550 mode, it indicates the same condition, instead of FIFO full. When the CPU reads USR, it sets this bit to logical 0.
0	RDR (RBR Data Ready). This bit is set to logical 1 to indicate that the received data are ready to be read by the CPU in the RBR or FIFO. When no data are left in the RBR or FIFO, the bit is set to logical 0.

11.3 Handshake Control Register (HCR) (Read/Write)

This register controls pins used with handshaking peripherals such as modems and also controls the diagnostic mode of the UART.

BIT	7	6	5	4	3	2	1	0
NAME	RESERVED			INTERNAL LOOPBACK ENABLE	IRQ ENABLE	LOOPBACK RI INPUT	RTS	DTR
DEFAULT	0	0	0	0	0	0	0	0

BIT	DESCRIPTION
7-5	Reserved.
4	<p>Internal Loopback Enable. When this bit is set to logic 1, the UART enters diagnostic mode, as follows:</p> <ul style="list-style-type: none"> (1) SOUT is forced to logic 1, and SIN is isolated from the communication link. (2) The modem output pins are set to their inactive state. (3) The modem input pins are isolated from the communication link and connect internally as DTR (bit 0 of HCR) →DSR#, RTS (bit 1 of HCR) →CTS#, Loopback RI input (bit 2 of HCR) → RI# and IRQ enable (bit 3 of HCR) →DCD#. <p>Aside from the above connections, the UART operates normally. This method allows the CPU to test the UART in a convenient way.</p>
3	IRQ Enable. The UART interrupt output is enabled by setting this bit to logic 1. In diagnostic mode, this bit is internally connected to the modem control input DCD#.
2	Loopback RI Input. This bit is only used in the diagnostic mode. In diagnostic mode, this bit is internally connected to the modem control input RI#.
1	RTS (Request to Send). This bit controls the RTS# output. The value of this bit is inverted and output to RTS#.
0	DTR (Data Terminal Ready). This bit controls the DTR# output. The value of this bit is inverted and output to DTR#.

11.4 Handshake Status Register (HSR) (Read/Write)

This register reflects the current state of four input pins used with handshake peripherals such as modems and records changes on these pins.

BIT	7	6	5	4	3	2	1	0
NAME	DCD	RI	DSR	CTS	TDCD	FERI	TDSR	TCTS
DEFAULT	NA	NA	NA	NA	NA	NA	NA	NA

BIT	DESCRIPTION
7	DCD (Data Carrier Detect). This bit is the inverse of the DCD# input and is equivalent to bit 3 of HCR in Loopback mode.
6	RI (Ring Indicator). This bit is the inverse of the RI# input and is equivalent to bit 2 of HCR in Loopback mode.
5	DSR (Data Set Ready). This bit is the inverse of the DSR# input and is equivalent to bit 0 of HCR in Loopback mode.
4	CTS (Clear to Send). This bit is the inverse of the CTS# input and is equivalent to bit 1 of HCR in Loopback mode.
3	TDCD (DCD# Toggling). This bit indicates that the state of the DCD# pin has changed after HSR is read by the CPU.
2	FERI (RI Falling Edge). This bit indicates that the RI# pin has changed from low to high after HSR is read by the CPU.
1	TDSR (DSR# Toggling). This bit indicates that the state of the DSR# pin has changed after HSR is read by the CPU.
0	TCTS (CTS# Toggling). This bit indicates that the state of the CTS# pin has changed



BIT	DESCRIPTION
	after HSR is read by the CPU.

11.5 UART FIFO Control Register (UFR) (Write only)

This register is used to control the FIFO functions of the UART.

BIT	7	6	5	4	3	2	1	0
NAME	MSB	LSB	RESERVED		DMA MODE SELECT	TRANSMITTER FIFO RESET	RECEIVER FIFO RESET	FIFO ENABLE
DEFAULT	0	0	NA	NA	0	0	0	0

BIT	DESCRIPTION
7	MSB (RX Interrupt Active Level). These two bits are used to set the active level of the receiver FIFO interrupt. The active level is the number of bytes that must be in the receiver FIFO to generate an interrupt.
6	
5-4	RESERVED.
3	DMS MODE SELECT. When this bit is set to logic 1, DMA mode changes from mode 0 to mode 1 if UFR bit 0 = 1.
2	TRANSMITTER FIFO RESET. Setting this bit to logic 1 resets the TX FIFO counter logic to its initial state.
1	RECEIVER FIFO RESET. Setting this bit to logic 1 resets the RX FIFO counter logic to its initial state.
0	FIFO ENABLE. This bit enables 16550 (FIFO) mode. This bit should be set to logic 1 before other UFR bits are programmed.

UFR_ BIT 7	UFR_ BIT 6	RX FIFO INTERRUPT ACTIVE LEVEL (BYTES)			
		FIFO_LEVEL_ MODE (CRF8_B7:6 = 00)	FIFO_LEVEL_ MODE (CRF8_B7:6 = 01)	FIFO_LEVEL_ MODE (CRF8_B7:6 = 10)	FIFO_LEVEL_ MODE (CRF8_B7:6 = 11)
0	0	01	16	80	112
0	1	04	32	88	116
1	0	08	48	96	120
1	1	14	64	104	124

11.6 Interrupt Status Register (ISR) (Read only)

This register reflects the UART interrupt status.

BIT	7	6	5	4	3	2	1	0
NAME	FIFOS ENABLED		RESERVED		INTERRUPT STATUS BIT 2	INTERRUPT STATUS BIT 1	INTERRUPT STATUS BIT 0	0 IF INTERRUPT PENDING



DEFAULT	0	0	0	0	0	0	0	1
---------	---	---	---	---	---	---	---	---

BIT	DESCRIPTION	
7-6	FIFOS ENABLED. Set to logical 1 when UFR, bit 0 = 1.	
5-4	RESERVED.	
3	INTERRUPT STATUS BIT 2. In 16450 mode, this bit is logical 0. In 16550 mode, bits 3 and 2 are set to logical 1 when a time-out interrupt is pending. Please see the table below.	
2	INTERRUPT STATUS BIT 1.	These two bits identify the priority level of the pending interrupt, as shown in the table below.
1	INTERRUPT STATUS BIT 0.	
0	0 IF INTERRUPT PENDING. This bit is logic 1 if there is no interrupt pending. If one of the interrupt sources has occurred, this bit is set to logical 0.	

ISR				INTERRUPT SET AND FUNCTION			
Bit 3	Bit 2	Bit 1	Bit 0	Interrupt priority	Interrupt Type	Interrupt Source	Clear Interrupt
0	0	0	1	-	-	No Interrupt pending	-
0	1	1	0	First	UART Receive Status	1. OER = 1 2. PBER = 1 3. NSER = 1 4. SBD = 1	Read USR
0	1	0	0	Second	RBR Data Ready	1. RBR data ready 2. FIFO interrupt active level reached	1. Read RBR 2. Read RBR until FIFO data under active level
1	1	0	0	Second	FIFO Data Timeout	Data present in RX FIFO for 4 characters period of time since last access of RX FIFO.	Read RBR
0	0	1	0	Third	TBR Empty	TBR empty	1. Write data into TBR 2. Read ISR (if priority is third)
0	0	0	0	Fourth	Handshake status	1. TCTS = 1 2. TDSR = 1 3. FERI = 1 4. TDCD = 1	Read HSR

** Bit 3 of ISR is enabled when bit 0 of UFR is logical 1.

11.7 Interrupt Control Register (ICR) (Read/Write)

This 8-bit register enables and disables the five types of controller interrupts separately. A selected interrupt can be enabled by setting the appropriate bit to logical 1. The interrupt system can be totally disabled by setting bits 0 through 3 to logical 0.

BIT	7	6	5	4	3	2	1	0
NAME	En_address_byte	RX_ctrl	RESERVED		EHSRI	EUSRI	ETBREI	ERDRI
DEFAULT	0	0	0	0	0	0	0	0

BIT	DESCRIPTION
7	En_address_byte. 0: Tx block will send data byte. (If enable 9bit mode function CRF2 Bit0=1)

BIT	DESCRIPTION
	1: Tx block will send address byte. (If enable 9bit mode function CRF2 Bit0=1)
6	RX_ctrl. 0: Rx block could receive data byte. (If enable 9bit mode function CRF2 Bit0=1) 1: Rx block could receive address byte. (If enable 9bit mode function CRF2 Bit0=1)
5-4	RESERVED.
3	EHSRI (Handshake Status Interrupt Enable). Set this bit to logical 1 to enable the handshake status register interrupt.
2	EUSRI (UART Receive Status Interrupt Enable). Set this bit to logical 1 to enable the UART status register interrupt.
1	ETBREI (TBR Empty Interrupt Enable). Set this bit to logical 1 to enable the TBR empty interrupt.
0	ERDRI (RBR Data Ready Interrupt Enable). Set this bit to logical 1 to enable the RBR data ready interrupt.

11.8 Programmable Baud Generator (BLL/BHL) (Read/Write)

Two 8-bit registers, BLL and BHL, compose a programmable baud generator that uses 24 MHz to generate a 1.8461 MHz frequency and divide it by a divisor from 1 to ($2^{16} - 1$). The output frequency of the baud generator is the baud rate multiplied by 16, and this is the base frequency for the transmitter and receiver. The table below illustrates the use of the baud generator with a frequency of 1.8461 MHz. In high-speed UART mode (CR0C, bits 7 and 6), the programmable baud generator directly uses 24 MHz and the same divisor as the normal speed divisor. As a result, in high-speed mode, the data transmission rate can be as high as 1.5M bps.

BAUD RATE FROM DIFFERENT PRE-DIVIDER			
Pre-Div: 13 1.8461M Hz	Pre-Div: 1.0 24M Hz	Decimal divisor used to generate 16X clock	Error Percentage
50	650	2304	**
75	975	1536	**
110	1430	1047	0.18%
134.5	1478.5	857	0.099%
150	1950	768	**
300	3900	384	**
600	7800	192	**
1200	15600	96	**
1800	23400	64	**
2000	26000	58	0.53%
2400	31200	48	**
3600	46800	32	**
4800	62400	24	**
7200	93600	16	**
9600	124800	12	**
19200	249600	6	**

BAUD RATE FROM DIFFERENT PRE-DIVIDER			
38400	499200	3	**
57600	748800	2	**
115200	1497600	1	**

** Unless specified, the error percentage for all of the baud rates is 0.16%.
 Note: Pre-Divisor is determined by CRF0 of UART A.

11.9 User-defined Register (UDR) (Read/Write)

This is a temporary register that can be accessed and defined by the user.

11.10 Extending FIFO

We support FIFO size extending to 32bytes for RX and TX block. (Enable bit: CRF8, Bit0)

11.11 UART RS485 Auto Flow Control

NCT6102D / NCT6106D supports RS485 auto flow control function for UARTA ~ UARTF. When enabling the RS485 auto control function, it will automatically drive RTS# pin to logic high or low for UARTA ~ UARTF when UART TX block transmits the data.

The diagram shown below illustrates the RS485 auto flow control function for UARTA ~ UARTF.

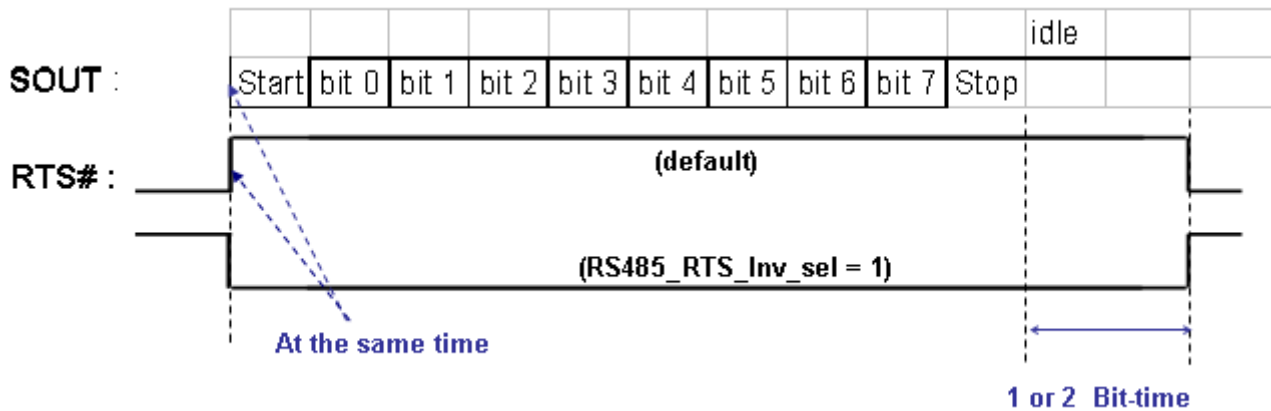

The default behavior of RTS# pin will drive logic high the time edge between **Start bit** and **bit0** when the UART TX Block start to transmits the data on SOUT pin. Then the RTS# pin will drive logic low later than **Stop bit** about 1 or 2 Bit-Time when UART TX Block completes the data transmission. The driving behavior of RTS# will be inverted when we set RS485_RTS_inv_sel bit = 1'b1. (Bit-time: Depends on the baud rate of transmission)

The following control register table relates to the RS485 auto flow control function for UARTA ~ UARTF.

	UARTA	UARTB	UARTC	UARTD	UARTE	UARTF
RTS485_enable	Logic Device 2, CRF2_Bit1	Logic Device 3, CRF2_Bit1	Logic Device 10, CRF2_Bit1	Logic Device 11, CRF2_Bit1	Logic Device 12, CRF2_Bit1	Logic Device 13, CRF2_Bit1

RTS485_inv_sel	Logic Device 2, CRF2_Bit4	Logic Device 3, CRF2_Bit4	Logic Device 10, CRF2_Bit4	Logic Device 11, CRF2_Bit4	Logic Device 12, CRF2_Bit4	Logic Device 13, CRF2_Bit4
RST_low_time_sel	Logic Device 2, CRF2_Bit5	Logic Device 3, CRF2_Bit5	Logic Device 10, CRF2_Bit5	Logic Device 11, CRF2_Bit5	Logic Device 12, CRF2_Bit5	Logic Device 13, CRF2_Bit5

11.12 UART 9BIT-MODE

11.12.1 Function Description

► **Tx function block:**

1. 9bit-TX block supports 9bit-mode or original RS232 mode TX signal output.
2. 9bit-TX block supports sending address byte
(Setting **En_9bit_mode =1** and **En_address_byte =1** will force parity bit turned to high bit)
3. 9bit-TX block supports 9bit-mode RS485 RTS or original RS232 mode RTS signal output.
4. 9bit-TX block supports 9bit-mode inverted and time selected for the RS485 RTS signal.
(RS485 RTS time selected: one or two TXC period)
5. 9bit-TX block supports clear “en_address_byte” bit automatic.

	Register location (UART A) Logic Device 2	Register location (UART B) Logic Device 3	Register location (UART C) Logic Device 10	Register location (UART D) Logic Device 11	Register location (UART E) Logic Device 12	Register location (UART F) Logic Device 13
En_address_byte	03f9, Bit7 (default)	02f9, Bit7 (default)	03f9, Bit7 (default)	03f9, Bit7 (default)	03f9, Bit7 (default)	03f9, Bit7 (default)

► **Rx function block:**

1. 9bit-RX block supports 9bit-mode or original RS232 mode RX signal output.
2. 9bit-RX block supports comparison between with the slave address and broadcast address byte determined by the two registers. (see blow: slave_address and slave_address_mask registers)



3. 9bit-RX block supports received address byte pass into RX block FIFO.
4. 9bit-RX block supports UART 9bit-mode IRQ output and could select to be issued only when receiving any address bytes or only received address matched.
5. 9bit-RX block will automatic modify parity bit of address/data byte to meet parity check from UART receiver block when using 9bit-bit mode.
6. 9bit-RX block supports different mode that have different functions by setting RX_ctrl_set[2:0].



(default: RX_ctrl_set[2:0] = 000)

	Register location (UART A) Logic Device 2	Register location (UART B) Logic Device 3	Register location (UART C) Logic Device 10	Register location (UART D) Logic Device 11	Register location (UART E) Logic Device 12	Register location (UART F) Logic Device 13
RX_ctrl_set[2]: (en_auto_only_addr_comp)	CRF2_B6	CRF2_B6	CRF2_B6	CRF2_B6	CRF2_B6	CRF2_B6
RX_ctrl_set[1]: (en_auto_RX_ctrl)	CRF2_B7	CRF2_B7	CRF2_B7	CRF2_B7	CRF2_B7	CRF2_B7
RX_ctrl_set[0]: (RX_ctrl)	03f9, Bit6 (default)	02f9, Bit6 (default)	03f9, Bit6 (default)	03f9, Bit6 (default)	03f9, Bit6 (default)	03f9, Bit6 (default)

RX_ctrl_set[2:0]	Function Description
000	<ol style="list-style-type: none"> 9bitmode RX block function will pass all data or address bytes to UART receiver block directly. 9bitmode RX block function will not compare any address byte. 9bitmode RX block function will correct parity check bit before sending any data or address byte into UART receiver block. 9bitmode RX block function will generate IRQ. (Refer to CRF6 description.)
001	<ol style="list-style-type: none"> 9bitmode RX block function will only pass address bytes to UART receiver block. 9bitmode RX block function will not compare any address byte. 9bitmode RX block function will correct parity check bit before sending any data or address byte into UART receiver block. 9bitmode RX block function will generate IRQ. (Refer to CRF6 description.)
010	<ol style="list-style-type: none"> 9bitmode RX block function will update RX_ctrl Bit automatically. When RX_ctrl = 0: If receive address byte, 9bitmode RX block function will update RX_ctrl=1 automatically. In order to receive address byte at next byte cycle. (RX block function will ignore the current address byte. Then the transmitter needs to resend this address byte again.) 9bitmode RX block function will compare the address byte automatically and will pass the matched address or not depending on CRF2_B2 setting. 9bitmode RX block function will correct parity check bit before sending any data or address byte into UART receiver block. 9bitmode RX block function will generate IRQ. (Refer to CRF6 description.)
011	<ol style="list-style-type: none"> 9bitmode RX block function will update RX_ctrl Bit automatically. When RX_ctrl = 1: If address byte matched, 9bitmode RX block function will update RX_ctrl=0 automatically. In order to receive data byte at next byte cycle.

RX_ctrl_set[2:0]	Function Description
	<ol style="list-style-type: none"> 2. 9bitmode RX block function will compare the address byte automatically and will pass the matched address or not depending on CRF2_B2 setting. 3. 9bitmode RX block function will correct parity check bit before sending any data or address byte into UART receiver block. 4. 9bitmode RX block function will generate IRQ. (Refer to CRF6 description.)
100 (The same as 000)	<ol style="list-style-type: none"> 1. 9bitmode RX block function will pass all data or address bytes to UART receiver block directly. 2. 9bitmode RX block function will not compare any address byte. 3. 9bitmode RX block function will correct parity check bit before sending any data or address byte into UART receiver block. 4. 9bitmode RX block function will generate IRQ. (Refer to CRF6 description.)
101 (The same as 001)	<ol style="list-style-type: none"> 1. 9bitmode RX block function will only pass address bytes to UART receiver block. 2. 9bitmode RX block function will not compare any address byte. 3. 9bitmode RX block function will correct parity check bit before sending any data or address byte into UART receiver block. 4. 9bitmode RX block function will generate IRQ. (Refer to CRF6 description.)
110	<ol style="list-style-type: none"> 1. 9bitmode RX block function will not update RX_ctrl Bit automatically. When RX_ctrl = 0: If receive address byte, in order to receive the address byte, we need set RX_ctrl = 1 manually. 2. 9bitmode RX block function will compare the address byte automatically and will pass the matched address or not depending on CRF2_B2 setting. 3. 9bitmode RX block function will correct parity check bit before sending any data or address byte into UART receiver block. 4. 9bitmode RX block function will generate IRQ. (Refer to CRF6 description.)
111	<ol style="list-style-type: none"> 1. 9bitmode RX block function will not update RX_ctrl Bit automatically. When RX_ctrl = 1: If address byte matched, in order to receive the proceeding data bytes, we need set RX_ctrl = 0 manually. 2. 9bitmode RX block function will compare the address byte automatically and will pass the matched address or not depending on CRF2_B2 setting. 3. 9bitmode RX block function will correct parity check bit before sending any data or address byte into UART receiver block. 4. 9bitmode RX block function will generate IRQ. (Refer to CRF6 description.)

11.12.2 Function Block

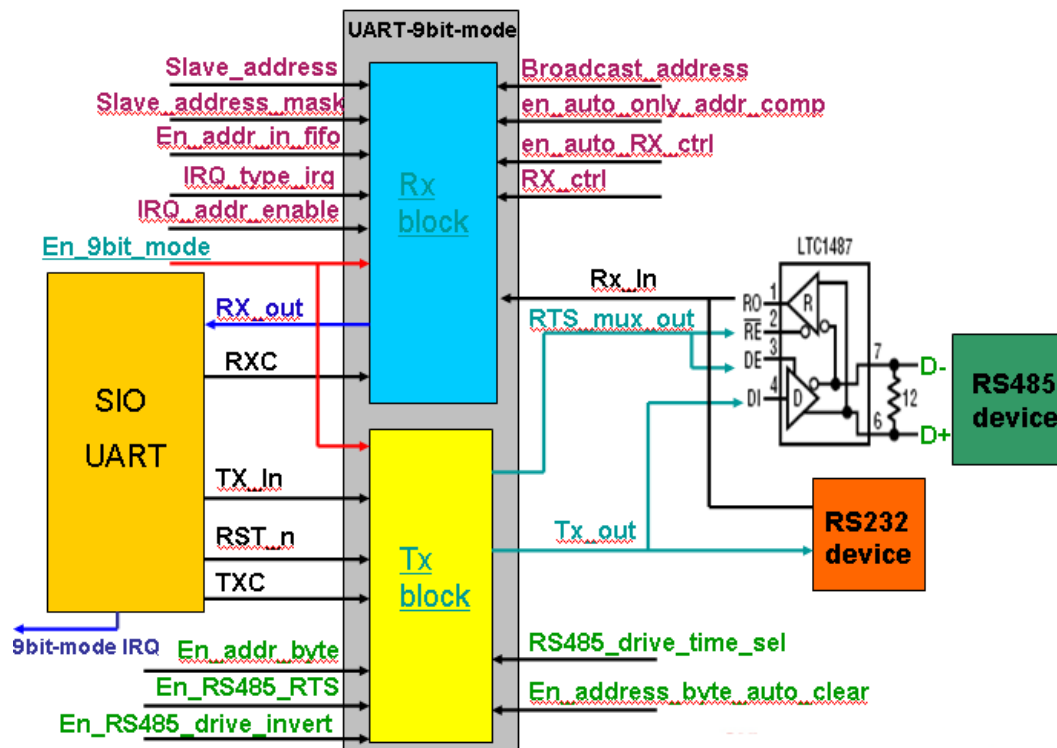

11.13 UART switch

Due to the limitation length of the cable for the communication of UART, We support 3 sets of switches to fix this limitation. They are UARTAB, UARTCD andUARTEF switches.

Switch Name	Switch Enable Bit	Description
UARTAB switch	Logic Device 02, IndexF8_Bit4	Conection with UARTA and UARTB
UARTCD switch	Logic Device 10, IndexF8_Bit4	Conection with UARTC and UARTD
UARTEF switch	Logic Device 12, IndexF8_Bit4	Conection with UARTE and UARTF

For example, if computer A and computer B will transfer data to each other with UART, but the distance between computer A and B is over the limitation length of the cable. See the figure11.13.1, the cable 1 is over the limitation. And we could use uart switch to fix this limitation. If the switch of computer1 is enabled, computer A could transfer data to computer 1 and computer 1 would bypass the data to computer B. In the same method, computer B also could achieve the goal to transfer data to computer A.

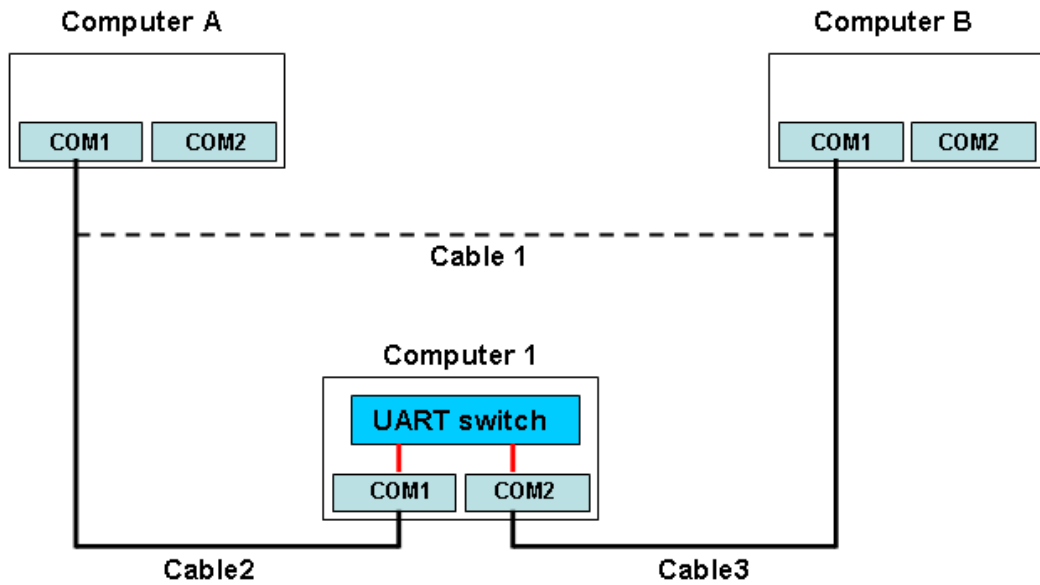

The connection of UART switch with single computer

We also could connect multi-switch to fix the limitation length of the cable, if the distance between computer A and computer B is too far. Figure 11.13.2 shows the connection method of multi-switch.

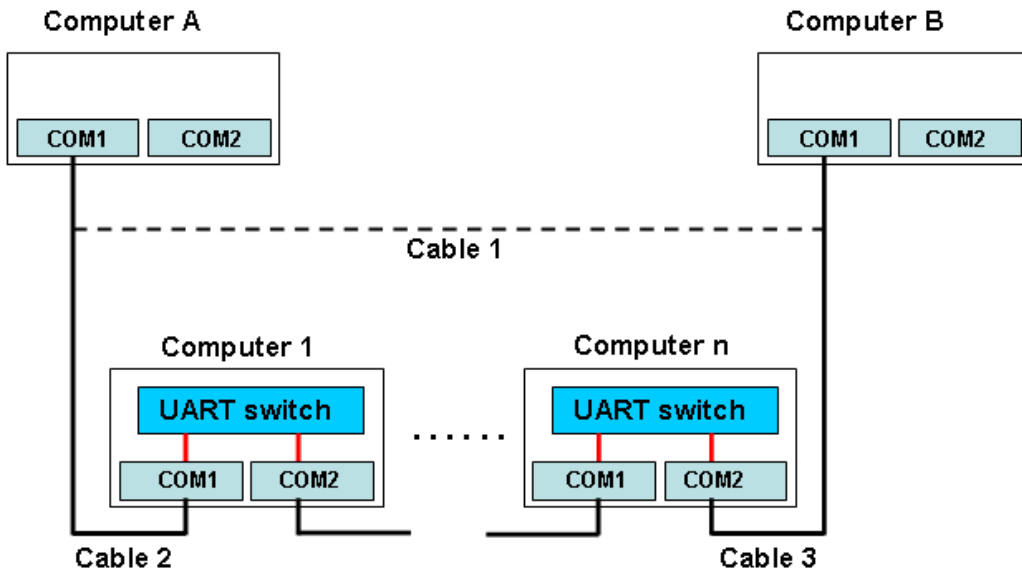

The connection of UART switch with multi-computer



12. PARALLEL PORT

12.1 Printer Interface Logic

The NCT6102D / NCT6106D parallel port can be attached to devices that accept eight bits of parallel data at standard TTL level. The NCT6102D / NCT6106D supports the IBM XT/AT compatible parallel port (SPP), the bi-directional parallel port (BPP), the Enhanced Parallel Port (EPP), and the Extended Capabilities Parallel Port (ECP).

The following tables show the pin definitions for different modes of the parallel port.

Table 12-1 Pin Descriptions for SPP, EPP, and ECP Modes

HOST CONNECTOR	PIN NUMBER OF NCT6102D / NCT6106D	PIN ATTRIBUTE	SPP	EPP	ECP
1	47	O	Nstb	nWrite	nSTB, HostClk ²
2-9	35-42	I/O	PD<7:0>	PD<7:0>	PD<7:0>
10	34	I	nACK	Intr	nACK, PeriphClk ²
11	33	I	BUSY	nWait	BUSY, PeriphAck ²
12	32	I	PE	PE	Peerror, nAckReverse ²
13	31	I	SLCT	Select	SLCT, Xflag ²
14	46	O	Nafd	nDStrb	nAFD, HostAck ²
15	45	I	nERR	nError	nFault ¹ , nPeriphRequest ²
16	44	O	Ninit	nInit	nINIT ¹ , nReverseRqst ²
17	43	O	nSLIN	nAstrb	nSLIN ¹ , ECPMode ²

Notes:

n<name > : Active Low

1. Compatible Mode
2. High Speed Mode
3. For more information, please refer to the IEEE 1284 standard.

HOST CONNECTOR	PIN NUMBER OF NCT6102D / NCT6106D	PIN ATTRIBUTE	SPP
1	47	O	nSTB
2	42	I/O	PD0
3	41	I/O	PD1
4	40	I/O	PD2
5	39	I/O	PD3
6	38	I/O	PD4
7	37	I/O	PD5
8	36	I/O	PD6
9	35	I/O	PD7
10	34	I	nACK
11	33	I	BUSY
12	32	I	PE
13	31	I	SLCT
14	46	O	nAFD



HOST CONNECTOR	PIN NUMBER OF NCT6102D / NCT6106D	PIN ATTRIBUTE	SPP
15	45	I	nERR
16	44	O	nINIT
17	43	O	nSLIN

12.2 Enhanced Parallel Port (EPP)

The following table lists the registers used in the EPP mode and identifies the bit map of the parallel port and EPP registers. Some of the registers are used in other modes as well.

Table 12-2 EPP Register Addresses

A2	A1	A0	REGISTER	NOTE
0	0	0	Data port (R/W)	1
0	0	1	Printer status buffer (Read)	1
0	1	0	Printer control latch (Write)	1
0	1	0	Printer control swapper (Read)	1
0	1	1	EPP address port (R/W)	2
1	0	0	EPP data port 0 (R/W)	2
1	0	1	EPP data port 1 (R/W)	2
1	1	0	EPP data port 2 (R/W)	2
1	1	1	EPP data port 2 (R/W)	2

Notes:

1. These registers are available in all modes.
2. These registers are available only in EPP mode.

Table 12-3 Address and Bit Map for SPP and EPP Modes

REGISTER	7	6	5	4	3	2	1	0
Data Port (R/W)	PD7	PD6	PD5	PD4	PD3	PD2	PD1	PD0
Status Buffer (Read)	BUSY#	ACK#	PE	SLCT	ERROR#	1	1	TMOUT
Control Swapper (Read)	1	1	1	IRQEN	SLIN	INIT#	AUTOFD#	STROBE#
Control Latch (Write)	1	1	DIR	IRQ	SLIN	INIT#	AUTOFD#	STROBE#
EPP Address Port (R/W)	PD7	PD6	PD5	PD4	PD3	PD2	PD1	PD0
EPP Data Port 0 (R/W)	PD7	PD6	PD5	PD4	PD3	PD2	PD1	PD0
EPP Data Port 1 (R/W)	PD7	PD6	PD5	PD4	PD3	PD2	PD1	PD0
EPP Data Port 2 (R/W)	PD7	PD6	PD5	PD4	PD3	PD2	PD1	PD0
EPP Data Port 3 (R/W)	PD7	PD6	PD5	PD4	PD3	PD2	PD1	PD0

Each register (or pair of registers, in some cases) is discussed below.

12.2.1 Data Port (Data Swapper)

The CPU reads the contents of the printer's data latch by reading the data port.



12.2.2 Printer Status Buffer

The CPU reads the printer status by reading the printer status buffer. The bit definitions are as follows:

BIT	7	6	5	4	3	2	1	0
NAME	BUSY#	ACK#	PE	SLCT	ERROR#	RESERVED		TMOUT
DEFAULT	NA	NA	NA	NA	NA	1	1	0

BIT	DESCRIPTION
7	BUSY#. This signal is active during data entry, when the printer is off-line during printing, when the print head is changing position, or during an error state. When this signal is active, the printer is busy and cannot accept data.
6	ACK#. This bit represents the current state of the printer's ACK# signal. A logical 0 means the printer has received a character and is ready to accept another. Normally, this signal is active for approximately 5 μ s before BUSY# stops.
5	PE. A logical 1 means the printer has detected the end of paper.
4	SLCT. A logical 1 means the printer is selected.
3	ERROR#. A logical 0 means the printer has encountered an error condition.
2-1	RESERVED.
0	TMOUT. This bit is only valid in EPP mode. A logical 1 indicates that a 10- μ s time-out has occurred on the EPP bus; a logical 0 means that no time-out error has occurred. Writing a logical 1 to this bit clears the time-out status bit; writing a logical 0 has no effect.

12.2.3 Printer Control Latch and Printer Control Swapper

The CPU reads the contents of the printer control latch by reading the printer control swapper. The bit definitions are as follows:

BIT	7	6	5	4	3	2	1	0
NAME	RESERVED		DIR	IRQ ENABLE	SLCT IN	INIT#	AUTO FD	STROBE
DEFAULT	1	1	NA	0	NA	NA	NA	NA

BIT	DESCRIPTION
7-6	RESERVED. These two bits are always read as logical 1 and can be written.
5	DIR (Direction Control Bit). When this bit is logical 1, the parallel port is in the input mode (read). When it is logical 0, the parallel port is in the output mode (write). This bit can be read and written. In SPP mode, this bit is invalid and fixed at zero.
4	IRQ ENABLE. A logical 1 allows an interrupt to occur when ACK# changes from low to high.
3	SLCT IN. a logical 1 selects the printer.
2	INIT#. A logical 0 starts the printer (50 microsecond pulse, minimum).
1	AUTO FD. A logical 1 causes the printer to line-feed after a line is printed.
0	STROBE. A logical 1 generates an active-high pulse for a minimum of 0.5 μ s to clock data into the printer. Valid data must be presented for a minimum of 0.5 μ s before and after the strobe pulse.



12.2.4 EPP Address Port

The address port is available only in EPP mode. Bit definitions are as follows:

BIT	7	6	5	4	3	2	1	0
NAME	PD7	PD6	PD5	PD4	PD3	PD2	PD1	PD0

The contents of DB0-DB7 are buffered (non-inverting) and output to ports PD0-PD7 during a write operation. The leading edge of IOW# causes an EPP address write cycle to be performed, and the trailing edge of IOW# latches the data for the duration of the EPP write cycle.

PD0-PD7 ports are read during a read operation. The leading edge of IOR# causes an EPP address read cycle to be performed and the data to be output to the host CPU.

12.2.5 EPP Data Port 0-3

These four registers are available only in EPP mode. The bit definitions for each data port are the same and as follows:

BIT	7	6	5	4	3	2	1	0
NAME	PD7	PD6	PD5	PD4	PD3	PD2	PD1	PD0

When any EPP data port is accessed, the contents of DB0-DB7 are buffered (non-inverting) and output to ports PD0-PD7 during a write operation. The leading edge of IOW# causes an EPP data write cycle to be performed, and the trailing edge of IOW# latches the data for the duration of the EPP write cycle.

During a read operation, ports PD0-PD7 are read, and the leading edge of IOR# causes an EPP read cycle to be performed and the data to be output to the host CPU.

12.2.6 EPP Pin Descriptions

EPP NAME	TYPE	EPP DESCRIPTION
Nwrite	O	Denotes read or write operation for address or data.
PD<0:7>	I/O	Bi-directional EPP address and data bus.
Intr	I	Used by peripheral device to interrupt the host.
Nwait	I	Inactivated to acknowledge that data transfer is complete. Activated to indicate that the device is ready for the next transfer.
PE	I	Paper end; same as SPP mode.
Select	I	Printer-select status; same as SPP mode.
NDStrb	O	This signal is active low. It denotes a data read or write operation.
Nerror	I	Error; same as SPP mode.
Ninits	O	This signal is active low. When it is active, the EPP device is reset to its initial operating mode.
NAStrb	O	This signal is active low. It denotes an address read or write operation.

12.2.7 EPP Operation

When EPP mode is selected, the PDx bus is in standard or bi-directional mode when no EPP read, write, or address cycle is being executed. In this situation, all output signals are set by the SPP Control Port and the direction is controlled by DIR of the Control Port.

A watchdog timer is required to prevent system lockup. The timer indicates that more than 10 μ S have elapsed from the start of the EPP cycle to the time WAIT# is deasserted. The current EPP cycle is aborted when a time-out occurs. The time-out condition is indicated in status bit 0.

The EPP operates on a two-phase cycle. First, the host selects the register within the device for subsequent operations. Second, the host performs a series of read and/or write byte operations to the selected register. Four operations are supported on the EPP: Address Write, Data Write, Address Read, and Data Read. All operations on the EPP device are performed asynchronously.

12.2.8 EPP Version 1.9 Operation

The EPP read/write operation can be completed under the following conditions:

- a. If nWait is active low, the read cycle (nWrite inactive high, nDStrb/nAStrb active low) or write cycle (nWrite active low, nDStrb/nAStrb active low) starts, proceeds normally, and is completed when nWait goes inactive high.
- b. If nWait is inactive high, the read/write cycle cannot start. It must wait until nWait changes to active low, at which time it starts as described above.

12.2.9 EPP Version 1.7 Operation

The EPP read/write cycle can start without checking whether nWait is active or inactive. Once the read/write cycle starts, however, it does not finish until nWait changes from active low to inactive high.

12.3 Extended Capabilities Parallel (ECP) Port

This port is software- and hardware-compatible with existing parallel ports, so the NCT6102D / NCT6106D parallel port may be used in standard printer mode if ECP is not required. It provides an automatic high burst-bandwidth channel that supports DMA for ECP in both the forward (host-to-peripheral) and reverse (peripheral-to-host) directions.

Small FIFOs are used in both forward and reverse directions to improve the maximum bandwidth requirement. The size of the FIFO is 16 bytes. The ECP port supports an automatic handshake for the standard parallel port to improve compatibility mode transfer speed.

The ECP port hardware supports run-length-encoded (RLE) decompression. Compression is accomplished by counting identical bytes and transmitting an RLE byte that indicates how many times the next byte is to be repeated. RLE compression is required; the hardware support is optional.

For more information about the ECP Protocol, refer to the Extended Capabilities Port Protocol and ISA Interface Standard.

The NCT6102D / NCT6106D ECP supports the following modes.

Table 12-4 ECP Mode Description

MODE	DESCRIPTION
000	SPP mode
001	PS/2 Parallel Port mode
010	Parallel Port Data FIFO mode
011	ECP Parallel Port mode
100	EPP mode (If this option is enabled in the CRF0h to select ECP/EPP mode)
101	Reserved
110	Test mode
111	Configuration mode

The mode selection bits are bits 7-5 of the Extended Control Register.

12.3.1 ECP Register and Bit Map

The next two tables list the registers used in ECP mode and provide a bit map of the parallel port and ECP registers.

Table 12-5 ECP Register Addresses

NAME	ADDRESS	I/O	ECP MODES	FUNCTION
data	Base+000h	R/W	000-001	Data Register
ecpAFifo	Base+000h	R/W	011	ECP FIFO (Address)
dsr	Base+001h	R	All	Status Register
dcr	Base+002h	R/W	All	Control Register
cFifo	Base+400h	R/W	010	Parallel Port Data FIFO
ecpDFifo	Base+400h	R/W	011	ECP FIFO (DATA)
tFifo	Base+400h	R/W	110	Test FIFO
cnfgA	Base+400h	R	111	Configuration Register A
cnfgB	Base+401h	R/W	111	Configuration Register B
ecr	Base+402h	R/W	All	Extended Control Register

Note: The base addresses are specified by CR60 and 61, which are determined by configuration register or hardware setting.

Table 12-6 Bit Map of the ECP Registers

	D7	D6	D5	D4	D3	D2	D1	D0	NOTE
Data	PD7	PD6	PD5	PD4	PD3	PD2	PD1	PD0	
ecpAFifo	Addr/RLE	Address or RLE field							2
Dsr	nBusy	nAck	Perror	Select	nFault	1	1	1	1
Dcr	1	1	Directio	ackIntEn	SelectIn	nInIt	Autofd	strobe	1
cFifo	Parallel Port Data FIFO								2
ecpFifo	ECP Data FIFO								2
tFifo	Test FIFO								2
cnfgA	0	0	0	1	0	0	0	0	
cnfgB	compress	intrValue	1	1	1	1	1	1	
Ecr	MODE			nErrIntrEn	dmaEn	serviceIntr	full	empty	



Notes:

1. These registers are available in all modes.
2. All FIFOs use one common 16-byte FIFO.

Each register (or pair of registers, in some cases) is discussed below.

12.3.2 Data and ecpAFifo Port

Modes 000 (SPP) and 001 (PS/2) (Data Port)

During a write operation, the Data Register latches the contents of the data bus on the rising edge of the input, and the contents of this register are output to PD0-PD7. During a read operation, ports PD0-PD7 are read and output to the host. The bit definitions are as follows:

BIT	7	6	5	4	3	2	1	0
NAME	PD7	PD6	PD5	PD4	PD3	PD2	PD1	PD0

Mode 011 (ECP FIFO-Address/RLE)

A data byte written to this address is placed in the FIFO and tagged as an ECP Address/RLE. The hardware at the ECP port transmits this byte to the peripheral automatically. This operation is defined only for the forward direction. The bit definitions are as follows:

BIT	7	6	5	4	3	2	1	0
NAME	Address/RLE	Address or RLE						

12.3.3 Device Status Register (DSR)

These bits are logical 0 during a read of the Printer Status Register. The bits of this status register are defined as follows:

BIT	7	6	5	4	3	2	1	0
NAME	nBusy	nAck	Perror	Select	nFault	1	1	1

BIT	DESCRIPTION
7	nBusy. This bit reflects the complement of the Busy input.
6	nAck. This bit reflects the nAck input.
5	Perror. This bit reflects the Perror input.
4	Select. This bit reflects the Select input.
3	nFault. This bit reflects the nFault input.
2-0	These three bits are not implemented and are always logical 1 during a read.

12.3.4 Device Control Register (DCR)

The bit definitions are as follows:

BIT	7	6	5	4	3	2	1	0
NAME	Reserved		Director	ackInEn	SelectIn	nInit	Autofd	Strobe
DEFAULT	1	1	NA	NA	NA	NA	NA	NA

BIT	DESCRIPTION
7-6	Reserved. These two bits are always read as logical 1 and cannot be written.
5	Director. If the mode is 000 or 010, this bit has no effect and the direction is always out. In other modes, 0: The parallel port is in the output mode. 1: The parallel port is in the input mode.
4	ackInEn (Interrupt Request Enable). When this bit is set to logical 1, it enables interrupt requests from the parallel port to the CPU on the low-to-high transition on ACK#.
3	SelectIn. This bit is inverted and output to the SLIN# output. 0: The printer is not selected. 1: The printer is selected.
2	nInit. This bit is output to the INIT# output.
1	Autofd. This bit is inverted and output to the AFD# output.
0	Strobe. This bit is inverted and output to the STB# output.

12.3.5 CFIFO (Parallel Port Data FIFO) Mode = 010

This mode is defined only for the forward direction. Bytes written or DMAed to this FIFO are transmitted by a hardware handshake to the peripheral using the standard parallel port protocol. Transfers to the FIFO are byte-aligned.

12.3.6 ECPDFIFO (ECP Data FIFO) Mode = 011

When the direction bit is 0, bytes written or DMAed to this FIFO are transmitted by a hardware handshake to the peripheral using the ECP parallel port protocol. Transfers to the FIFO are byte-aligned.

When the direction bit is 1, data bytes from the peripheral are read via automatic hardware handshake from ECP into this FIFO. Reads or DMAs from the FIFO return bytes of ECP data to the system.

12.3.7 TFIFO (Test FIFO Mode) Mode = 110

Data bytes may be read, written, or DMAed to or from the system to this FIFO in any direction. Data in the tFIFO is not transmitted to the parallel port lines. However, data in the tFIFO may be displayed on the parallel port data lines.

12.3.8 CNFGA (Configuration Register A) Mode = 111

This register is a read-only register. When it is read, 10H is returned. This indicates that this is an 8-bit implementation.

12.3.9 CNFGB (Configuration Register B) Mode = 111

The bit definitions are as follows:

BIT	7	6	5	4	3	2	1	0
NAME	COMPRESS	intrVALUE	IRQx2	IRQx1	IRQx0	RESERVED		
DEFAULT	0	0	0	0	0	1	1	1



BIT	DESCRIPTION																	
7	Compress. This bit is read-only. It is logical 0 during a read, which means that this chip does not support hardware RLE compression.																	
6	intrValue. Returns the value on the ISA IRQ line to determine possible conflicts.																	
5	IRQx2.	Reflects the IRQ resource assigned for ECP port.																
		<table border="1"> <thead> <tr> <th>cnfgB[5:3]</th> <th>IRQ resource</th> </tr> </thead> <tbody> <tr> <td>000</td> <td>Reflects other IRQ resources selected by PnP register (default)</td> </tr> <tr> <td>001</td> <td>IRQ7</td> </tr> <tr> <td>010</td> <td>IRQ9</td> </tr> <tr> <td>011</td> <td>IRQ10</td> </tr> <tr> <td>100</td> <td>IRQ11</td> </tr> <tr> <td>101</td> <td>IRQ14</td> </tr> <tr> <td>110</td> <td>IRQ15</td> </tr> <tr> <td>111</td> <td>IRQ5</td> </tr> </tbody> </table>	cnfgB[5:3]	IRQ resource	000	Reflects other IRQ resources selected by PnP register (default)	001	IRQ7	010	IRQ9	011	IRQ10	100	IRQ11	101	IRQ14	110	IRQ15
cnfgB[5:3]	IRQ resource																	
000	Reflects other IRQ resources selected by PnP register (default)																	
001	IRQ7																	
010	IRQ9																	
011	IRQ10																	
100	IRQ11																	
101	IRQ14																	
110	IRQ15																	
111	IRQ5																	
4	IRQx1.																	
3	IRQx0.																	
2-0	Reserved. These three bits are logical 1 during a read and can be written.																	

12.3.10 ECR (Extended Control Register) Mode = all

This register controls the extended ECP parallel port functions. The bit definitions are follows:

BIT	7	6	5	4	3	2	1	0
NAME	MODE			nErrIntrEn	dmaEn	ServiceIntr	Full	Empty
DEFAULT	0	0	0	1	0	1	0	1

BIT	DESCRIPTION	
7-5	Mode. Read/Write. These bits select the mode.	
	000	Standard Parallel Port (SPP) mode. The FIFO is reset in this mode.
	001	PS/2 Parallel Port mode. This is the same as SPP mode except that direction may be used to tri-state the data lines. Furthermore, reading the data register returns the value on the data lines, not the value in the data register.
	010	Parallel Port FIFO mode. This is the same as SPP mode except that bytes are written or DMAed to the FIFO. FIFO data are automatically transmitted using the standard parallel port protocol. This mode is useful only when direction is 0.
	011	ECP Parallel Port Mode. When the direction is 0 (forward direction), bytes placed into the ecpDFifo and bytes written to the ecpAFifo are placed in a single FIFO and automatically transmitted to the peripheral using the ECP Protocol. When the direction is 1 (reverse direction), bytes are moved from the ECP parallel port and packed into bytes in the ecpDFifo.
	100	EPP Mode. EPP mode is activated if the EPP mode is selected.

BIT	DESCRIPTION	
	101	Reserved.
	110	Test Mode. The FIFO may be written and read in this mode, but the data is not transmitted on the parallel port.
	111	Configuration Mode. The configA and configB registers are accessible at 0x400 and 0x401 in this mode.
4	nErrIntrEn. Read/Write (Valid only in ECP Mode) 0: Enables the interrupt generated on the falling edge of nFault. This prevents interrupts from being lost in the time between the read of the ECR and the write of the ECR. 1: Disables the interrupt generated on the asserting edge of nFault.	
3	dmaEn. Read/Write. 0: Disable DMA unconditionally. 1: Enable DMA.	
2	serviceIntr. Read/Write. 0: Enable one of the following cases of interrupts. When one of the serviced interrupts occurs, this bit is set to logical 1 by the hardware. This bit must be reset to logical 0 to re-enable the interrupts. (a) dmaEn = 1: During DMA, this bit is set to logical 1 when terminal count is reached. (b) dmaEn = 0, direction = 0: This bit is set to logical 1 whenever there are writeIntr threshold or more bytes free in the FIFO. (c) dmaEn = 0, direction = 1: This bit is set to logical 1 whenever there are readIntr threshold or more valid bytes to be read from the FIFO. 1: Disable DMA and all of the service interrupts. Writing a logical 1 to this bit does not cause an interrupt.	
1	Full. Read Only. 0: The FIFO has at least one free byte. 1: The FIFO is completely full; it cannot accept another byte.	
0	Empty. Read Only. 0: The FIFO contains at least one byte of data. 1: The FIFO is completely empty.	

12.3.11 ECP Pin Descriptions

NAME	TYPE	DESCRIPTION
Nstrobe (HostClk)	O	This pin loads data or address into the slave on its asserting edge during write operations. This signal handshakes with Busy.
PD<7:0>	I/O	These signals contain address, data or RLE data.
nAck (PeriphClk)	I	This signal indicates valid data driven by the peripheral when asserted. This signal handshakes with nAutoFd in reverse.
Busy (PeriphAck)	I	This signal deasserts to indicate that the peripheral can accept data. In the reverse direction, it indicates whether the data lines contain ECP command information or data. Normal data are transferred when Busy (PeriphAck) is high, and an 8-bit command is transferred when it is low.

NAME	TYPE	DESCRIPTION
Perror (nAckReverse)	I	This signal is used to acknowledge a change in the direction of the transfer (asserted = forward). The peripheral drives this signal low to acknowledge nReverseRequest. The host relies upon nAckReverse to determine when it is permitted to drive the data bus.
Select (Xflag)	I	Indicates printer on-line.
NautoFd (HostAck)	O	Requests a byte of data from the peripheral when it is asserted. In the forward direction, this signal indicates whether the data lines contain ECP address or data. Normal data are transferred when nAutoFd (HostAck) is high, and an 8-bit command is transferred when it is low.
nFault (nPeriphReuqest)	I	Generates an error interrupt when it is asserted. This signal is valid only in the forward direction. The peripheral is permitted (but not required) to drive this pin low to request a reverse transfer during ECP mode.
nlNit (nReverseRequest)	O	This signal sets the transfer direction (asserted = reverse, deasserted = forward). This pin is driven low to place the channel in the reverse direction.
nSelectIn (ECPMode)	O	This signal is always deasserted in ECP mode.

12.3.12 ECP Operation

The host must negotiate on the parallel port to determine if the peripheral supports the ECP protocol before ECP operation. After negotiation, it is necessary to initialize some of the port bits.

- (a) Set direction = 0, enabling the drivers.
- (b) Set strobe = 0, causing the nStrobe signal to default to the deasserted state.
- I Set autoFd = 0, causing the nAutoFd signal to default to the deasserted state.
- (d) Set mode = 011 (ECP Mode)

ECP address/RLE bytes or data bytes may be sent automatically by writing the ecpAFifo or ecpDFifo, respectively.

12.3.12.1. Mode Switching

The software must handle P1284 negotiation and all operations prior to a data transfer in SPP or PS/2 modes (000 or 001). The hardware provides an automatic control line handshake, moving data between the FIFO and the ECP port, only in the data transfer phase (mode 011 or 010).

If the port is in mode 000 or 001, it may switch to any other mode. If the port is not in mode 000 or 001, it can only be switched into mode 000 or 001. The direction can only be changed in mode 001.

In extended forward mode, the software should wait for the FIFO to be empty before switching back to mode 000 or 001. In ECP reverse mode, the software should wait for all the data to be read from the FIFO before changing back to mode 000 or 001.



12.3.12.2. Command/Data

ECP mode allows the transfer of normal 8-bit data or 8-bit commands. In the forward direction, normal data are transferred when HostAck is high, and an 8-bit command is transferred when HostAck is low. The most significant bits of the command indicate whether it is a run-length count (for compression) or a channel address.

In the reverse direction, normal data are transferred when PeriphAck is high, and an 8-bit command is transferred when PeriphAck is low. The most significant bit of the command is always zero.

12.3.12.3. Data Compression

The NCT6102D / NCT6106D hardware supports RLE decompression and can transfer compressed data to a peripheral. Odd (RLE) compression is not supported in the hardware, however. In order to transfer data in ECP mode, the compression count is written to ecpAFifo and the data byte is written to ecpDFifo.

12.3.13FIFO Operation

The FIFO threshold is set in CR5. All data transferred to or from the parallel port can proceed in DMA or Programmed I/O (non-DMA) mode, as indicated by the selected mode. The FIFO is used in Parallel Port FIFO mode or ECP Parallel Port Mode. After a reset, the FIFO is disabled.

12.3.14DMA Transfers

DMA transfers are always to or from the ecpDFifo, tFifo, or Cfifo. DMA uses the standard PC DMA services. The ECP requests DMA transfers from the host by activating the PDRQ pin. The DMA empties or fills the FIFO using the appropriate direction and mode. When the terminal count in the DMA controller is reached, an interrupt is generated, and serviceIntr is asserted, which will disable the DMA.

12.3.15Programmed I/O (NON-DMA) Mode

The ECP and parallel port FIFOs can also be operated using interrupt-driven, programmed I/O. Programmed I/O transfers are

1. To the ecpDFifo at 400H and ecpAFifo at 000H
2. From the ecpDFifo located at 400H
3. To / from the tFifo at 400H.

The host must set dmaEn and serviceIntr to 0 and also must set the direction and state accordingly in the programmed I/O transfers.

The ECP requests programmed I/O transfers from the host by activating the IRQ pin. The programmed I/O empties or fills the FIFO using the appropriate direction and mode.

13. KEYBOARD CONTROLLER

The NCT6102D / NCT6106D KBC (8042 with licensed KB BIOS) circuit is designed to provide the functions needed to interface a CPU with a keyboard and/or a PS/2 mouse and can be used with IBM®-compatible personal computers or PS/2-based systems. The controller receives serial data from the keyboard or PS/2 mouse, checks the parity of the data, and presents the data to the system as a byte of data in its output buffer. Then, the controller asserts an interrupt to the system when data are placed in its output buffer. The keyboard and PS/2 mouse are required to acknowledge all data transmissions. No transmission should be sent to the keyboard or PS/2 mouse until an acknowledgement is received for the previous data byte.

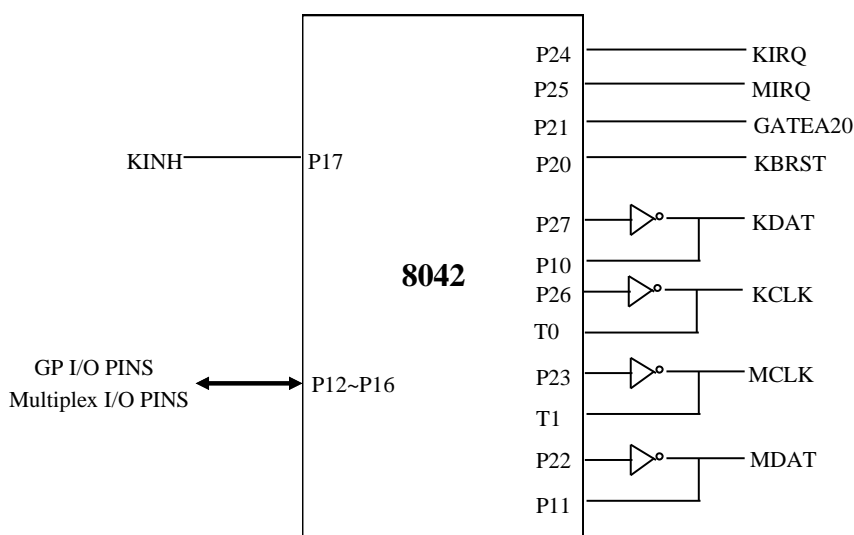

Figure 13-1 Keyboard and Mouse Interface

13.1 Output Buffer

The output buffer is an 8-bit, read-only register at I/O address 60H (Default, PnP programmable I/O address LD5-CR60 and LD5-CR61). The keyboard controller uses the output buffer to send the scan code (from the keyboard) and required command bytes to the system. The output buffer can only be read when the output buffer full bit in the register (in the status register) is logical 1.

13.2 Input Buffer

The input buffer is an 8-bit, write-only register at I/O address 60h or 64h (Default, PnP programmable I/O address LD5-CR60, LD5-CR61, LD5-CR62, and LD5-CR63). Writing to address 60h sets a flag to indicate a data write; writing to address 64h sets a flag to indicate a command write. Data written to I/O address 60h is sent to the keyboard (unless the keyboard controller is expecting a data byte) through the controller's input buffer only if the input buffer full bit (in the status register) is logical 0.

13.3 Status Register

The status register is an 8-bit, read-only register at I/O address 64h (Default, PnP programmable I/O address LD5-CR62 and LD5-CR63) that holds information about the status of the keyboard controller and interface. It may be read at any time.

Table 13-1 Bit Map of Status Register

BIT	BUT FUNCTION	DESCRIPTION
0	Output Buffer Full	0: Output buffer empty 1: Output buffer full
1	Input Buffer Full	0: Input buffer empty 1: Input buffer full
2	System Flag	This bit may be set to 0 or 1 by writing to the system flag bit in the command byte of the keyboard controller. It defaults to 0 after a power-on reset.
3	Command/Data	0: Data byte 1: Command byte
4	Inhibit Switch	0: Keyboard is inhibited 1: Keyboard is not inhibited
5	Auxiliary Device Output Buffer	0: Auxiliary device output buffer empty 1: Auxiliary device output buffer full
6	General Purpose Time-out	0: No time-out error 1: Time-out error
7	Parity Error	0: Odd parity 1: Even parity (error)

13.4 Commands

Table 13-2 KBC Command Sets

COMMAND	FUNCTION																		
20h	Read Command Byte of Keyboard Controller																		
60h	Write Command Byte of Keyboard Controller <table border="1" data-bbox="555 564 1138 934"> <thead> <tr> <th>BIT</th> <th>BIT DEFINITION</th> </tr> </thead> <tbody> <tr> <td>7</td> <td>Reserved</td> </tr> <tr> <td>6</td> <td>IBM Key board Translate Mode</td> </tr> <tr> <td>5</td> <td>Disable Auxiliary Device</td> </tr> <tr> <td>4</td> <td>Disable Key board</td> </tr> <tr> <td>3</td> <td>Reserve</td> </tr> <tr> <td>2</td> <td>System Flag</td> </tr> <tr> <td>1</td> <td>Enable Auxiliary Interrupt</td> </tr> <tr> <td>0</td> <td>Enable Key board Interrupt</td> </tr> </tbody> </table>	BIT	BIT DEFINITION	7	Reserved	6	IBM Key board Translate Mode	5	Disable Auxiliary Device	4	Disable Key board	3	Reserve	2	System Flag	1	Enable Auxiliary Interrupt	0	Enable Key board Interrupt
BIT	BIT DEFINITION																		
7	Reserved																		
6	IBM Key board Translate Mode																		
5	Disable Auxiliary Device																		
4	Disable Key board																		
3	Reserve																		
2	System Flag																		
1	Enable Auxiliary Interrupt																		
0	Enable Key board Interrupt																		
A4h	Test Password Returns 0Fah if Password is loaded Returns 0F1h if Password is not loaded																		
A5h	Load Password Load Password until a logical 0 is received from the system																		
A6h	Enable Password Enable the checking of keystrokes for a match with the password																		
A7h	Disable Auxiliary Device Interface																		
A8h	Enable Auxiliary Device Interface																		
A9h	Interface Test <table border="1" data-bbox="555 1335 1198 1568"> <thead> <tr> <th>BIT</th> <th>BIT DEFINITION</th> </tr> </thead> <tbody> <tr> <td>00</td> <td>No Error Detected</td> </tr> <tr> <td>01</td> <td>Auxiliary Device "Clock" line is stuck low</td> </tr> <tr> <td>02</td> <td>Auxiliary Device "Clock" line is stuck high</td> </tr> <tr> <td>03</td> <td>Auxiliary Device "Data" line is stuck low</td> </tr> <tr> <td>04</td> <td>Auxiliary Device "Data" line is stuck low</td> </tr> </tbody> </table>	BIT	BIT DEFINITION	00	No Error Detected	01	Auxiliary Device "Clock" line is stuck low	02	Auxiliary Device "Clock" line is stuck high	03	Auxiliary Device "Data" line is stuck low	04	Auxiliary Device "Data" line is stuck low						
BIT	BIT DEFINITION																		
00	No Error Detected																		
01	Auxiliary Device "Clock" line is stuck low																		
02	Auxiliary Device "Clock" line is stuck high																		
03	Auxiliary Device "Data" line is stuck low																		
04	Auxiliary Device "Data" line is stuck low																		
Aah	Self-test Returns 055h if self-test succeeds																		
Abh	Interface Test <table border="1" data-bbox="548 1692 1232 1925"> <thead> <tr> <th>BIT</th> <th>BIT DEFINITION</th> </tr> </thead> <tbody> <tr> <td>00</td> <td>No Error Detected</td> </tr> <tr> <td>01</td> <td>Key board "Clock" line is stuck low</td> </tr> <tr> <td>02</td> <td>Key board "Clock" line is stuck high</td> </tr> <tr> <td>03</td> <td>Key board "Data" line is stuck low</td> </tr> <tr> <td>04</td> <td>Key board "Data" line is stuck high</td> </tr> </tbody> </table>	BIT	BIT DEFINITION	00	No Error Detected	01	Key board "Clock" line is stuck low	02	Key board "Clock" line is stuck high	03	Key board "Data" line is stuck low	04	Key board "Data" line is stuck high						
BIT	BIT DEFINITION																		
00	No Error Detected																		
01	Key board "Clock" line is stuck low																		
02	Key board "Clock" line is stuck high																		
03	Key board "Data" line is stuck low																		
04	Key board "Data" line is stuck high																		

COMMAND	FUNCTION
Adh	Disable Keyboard Interface
Aeh	Enable Keyboard Interface
C0h	Read Input Port (P1) and send data to the system
C1h	Continuously puts the lower four bits of Port1 into the STATUS register
C2h	Continuously puts the upper four bits of Port1 into the STATUS register
D0h	Send Port 2 value to the system
D1h	Only set / reset GateA20 line based on system data bit 1
D2h	Send data back to the system as if it came from the Keyboard
D3h	Send data back to the system as if it came from Auxiliary Device
D4h	Output next received byte of data from system to Auxiliary Device
E0h	Reports the status of the test inputs
FXh	Pulse only RC (the reset line) low for 6 μ s if the Command byte is even

13.5 Hardware GATEA20/Keyboard Reset Control Logic

The KBC includes hardware control logic to speed-up GATEA20 and KBRESET. This control logic is controlled by LD5-CRF0 as follows:

13.5.1 KB Control Register (Logic Device 5, CR-F0)

BIT	7	6	5	4	3	2	1	0
NAME	KCLKS1	KCLKS0	RESERVED			P92EN	HGA20	HKBRST#
DEFAULT	1	0	0	0	0	0	0	0

BIT	DESCRIPTION	
7	KCLKS1.	Select the KBC clock rate. Bits 7 6 0 0: Reserved 0 1: Reserved 1 0: KBC clock input is 12 MHz. 1 1: Reserved
6	KCLKS0.	
5-3	RESERVED.	
2	P92EN (Port 92 Enable). 1: Enables Port 92 to control GATEA20 and KBRESET. 0: Disables Port 92 functions.	
1	HGA20 (Hardware GATEA 20). 1: Selects hardware GATE A20 control logic to control GATE A20 signal. 0: Disables GATEA20 control logic functions.	
0	HKBRST# (Hardware Keyboard Reset). 1: Selects hardware KB RESET control logic to control KBRESET signal. 0: Disables hardware KB RESET control logic function.	

When the KBC receives data that follows a "D1" command, the hardware control logic sets or clears GATE A20 according to received data bit 1. Similarly, the hardware control logic sets or clears KBRESET depending on received data bit 0. When the KBC receives an "FE" command, the KBRESET is pulse low for 6 μ s (Min.) with a 14 μ s (Min.) delay.

GATE A20 and KBRESET are controlled by either software or hardware logic, and they are mutually exclusive. Then, GATE A20 and KBRESET are merged with Port92 when the P92EN bit is set.

13.5.2 Port 92 Control Register (Default Value = 0x24)

BIT	7	6	5	4	3	2	1	0
NAME	RES. (0)		RES. (1)	RES. (0)		RES. (1)	SGA20	PLKBRST#
DEFAULT	0	0	1	0	0	1	0	0

BIT	DESCRIPTION
7-6	RES. (0)
5	RES. (1)
4-3	RES. (0)
2	RES. (1)
1	SGA20 (Special GATE A20 Control) 1: Drives GATE A20 signal to high. 0: Drives GATE A20 signal to low.
0	PLKBRST# (Pulled-low KBRESET). A logical 1 on this bit causes KBRESET to drive low for 6 μ S(Min.) with a 14 μ S(Min.) delay. Before issuing another keyboard-reset command, the bit must be cleared.



14. CONSUMER INFRARED REMOTE (CIR)

Regarding the receiving of IR Block, the hardware uses the sampling rates of 1us, 25us, 50us and 100us to calculate the widths of H Level and L Level. The results are saved/stored in 32*8 RX FIFO. The max widths of H Level and L Level will be determined by Sample Limit Count Register. During the receiving, the hardware will reflect the FIFO status in RX FIFO Status Register. In addition, the hardware also generates status, such as Data Ready, Trigger Level Reach, FIFO Overrun and FIFO underrun, in RC Status Register.

As for the transmission, the user has to set up the Carrier frequency and the transmission mode first and then writes the widths of H Level and L Level via TX FIFO. The hardware will add Carrier to H Level according to the transmission mode.

14.1 CIR Register Table

Table 14-1 CIR Register Table

RC Block										
ExtAddr	Name	7	6	5	4	3	2	1	0	
base+0	IRCON	R	WIREN	TXEN	RXEN	WRXINV	RXINV	Sample Period Select		
base+1	IRSTS	RDR	RTR	PE	RFO	TE	TTR	TFU	GH	
base+2	IREN	RDR	RTR	PE	RFO	TE	TTR	TFU	GH	
base+3	RXFCONT	RXFIFO Count								
base+4	CP	MODE	Reserved						Carrier Prescalar	
base+5	CC	Carrier Period								
base+6	SLCH	Sample Limit Count High Byte								
base+7	SLCL	Sample Limit Count Low Byte								
base+8	FIFOCON	TXFIFOCLR	R	Tx Trigger Level		RXFIFOCLR	R	Rx Trigger Level		
base+9	IRFIFOSTS	IR_Pending	RX_GS	RX_FTA	RX_Empty	RX_Full	TX_FTA	TX_Empty	TX_Full	
base+A	SRXFIFO	Sample RX FIFO								
base+B	TXFCONT	TX FIFO Count								
base+C	STXFIFO	Sample TX FIFO								
base+D	FCCH	Frame Carrier Count High Byte								
base+E	FCCL	Frame Carrier Count Low Byte								
base+F	IRFSM	R	Decoder FSM			R	Encoder FSM			

14.1.1 IR Configuration Register – Base Address + 0

Attribute: Read/Write

Size: 8 bits

BIT	7	6	5	4	3	2	1	0
NAME	Resevered	WIREN	TXEN	RXEN	WRXINV	RXINV	Sample Period Select	
DEFAULT	0	0	0	0	0	1	0	0

BIT	DESCRIPTION
7	Resevered.



6	Wide-band IR Enable
5	TX Enable 1: Transmission Enable. After confirming that FIFO is not empty, the transmission starts (the hardware will wait until TX FIFO data are written). If TX Enable is set to 0 during the transmission, the transmission stops when the transmission of FIFO data is completed. 0: Transmission Disable.
4	RX Enable
3	Wide-band IR Rx Invert Enable 0: Dongle Carrier ON is high, OFF (Idle) is low. 1: Dongle Carrier ON is low, OFF (Idle) is high.
2	IR Rx Invert Enable 0: Dongle Carrier ON is high, OFF (Idle) is low. 1: Dongle Carrier ON is low, OFF (Idle) is high.
1~0	Sample Period Select 00:1us, 01: 25us, 10: 50us, 11: 100us Note: In the 1us mode, the pulse mode will not function due to the IR regulations.

14.1.2 IR Status Register – Base Address + 1

Attribute: Read/Write

Size: 8 bits

BIT	7	6	5	4	3	2	1	0
Name	RDR	RTR	PE	RFO	TE	TTR	TFU	GH
DEFAULT	0	0	0	0	0	0	0	0

BIT	DESCRIPTION
7	RX Data Ready (Writing 1 will clear the bit).
6	RX FIFO Trigger Level Reach (Writing 1 will clear the bit).
5	Packet End (Writing 1 will clear the bit).
4	RX FIFO Overrun (Overrun and Data Ready will be simultaneously generated. Writing 1 will clear the bit).
3	TX FIFO Empty (Writing 1 will clear the bit).
2	TX FIFO Trigger Level Reach (Writing 1 will clear the bit).
1	TX FIFO Underrun (Writing 1 will clear the bit).
0	Min Length Detected (Writing 1 will clear the bit) 1: The IR Data length received is shorter than the default value. 0: The IR Data length received is longer than the default value.

14.1.3 IR Interrupt Configuration Register – Base Address + 2

Attribute: Read/Write

Size: 8 bits



BIT	7	6	5	4	3	2	1	0
NAME	RDR	RTR	PE	RFO	TE	TTR	TFU	GH
DEFAULT	0	0	0	0	0	0	0	0

1: Enable interrupt; 0: Disable interrupt

BIT	DESCRIPTION
7	RX Data Ready
6	RX FIFO Trigger Level Reach
5	Packet End
4	RX FIFO Overrun (Overrun and Data Ready will be simultaneously generated).
3	TX FIFO Empty
2	TX FIFO Trigger Level Reach
1	TX FIFO Underrun
0	Min Length Detected

Note. When an Interrupt occurs, it only can be cleared by writing IR Status Register to 1.

14.1.4 RX FIFO Count– Base Address + 5

Attribute: Read

Size: 8 bits

BIT	7	6	5	4	3	2	1	0
NAME	FIFO Count							
DEFAULT	0	0	0	0	0	0	0	0

1: Enable; 0: Disable

BIT	DESCRIPTION
7~0	RX FIFO Count

14.1.5 IR TX Carrier Prescalar Configuration Register (CP) – Base Address + 4

Attribute: Read/Write

Size: 8 bits

BIT	7	6	5	4	3	2	1	0
NAME	Mode	Reserved						CP
DEFAULT	0	0	0	0	0	0	0	0

BIT	DESCRIPTION
7	Mode 0 : DC Mode



	1 : Pulse Mode
6~1	Reserved.
0	Carrier Prescalar (CP). This bit is set for the Prescalar value of the IR TX carrier frequency.

14.1.6 IR TX Carrier Period Configuration Register (CC) – Base Address + 5

Attribute: Read/Write

Size: 8 bits

BIT	7	6	5	4	3	2	1	0
NAME	Carrier Period (CC)							
DEFAULT	0	0	0	0	0	0	0	0

BIT	DESCRIPTION
7~0	This byte is set for IR TX carrier period. The actual carrier period will be: $Period = 2 * (2^{(CP*2)} * (CC+1) / (System\ Clock))$, where the frequency = 1 / period, and System Clock = 24MHz. Setting CP and CC to 0 will cause stop the device to from use using anyno carrier at all (that is, no light modulation, just constant on and off periods). The period count value CC can be any number from 0 to 255.

14.1.7 IR RX Sample Limited Count High Byte Register (RCLCH) – Base Address + 6

Attribute: Read/Write

Size: 8 bits

BIT	7	6	5	4	3	2	1	0
NAME	Sample Limited Count High Byte							
DEFAULT	0	0	0	0	0	0	0	0

BIT	DESCRIPTION
7~0	This byte is defined as the high byte of the limited count in the IR RX mode.

14.1.8 IR RX Sample Limited Count Low Byte Register (RCLCL) – Base Address + 7

Attribute: Read/Write

Size: 8 bits

BIT	7	6	5	4	3	2	1	0
NAME	Sample Limited Count low Byte							
DEFAULT	0	0	0	0	0	0	0	0

BIT	DESCRIPTION
7~0	This byte is defined as the low byte of the limited count in the IR RX mode.

Note. (RCLCH, RCLCL) is defined as 16 bits value of the limited count in the IR RX mode. When the RX date length reaches the limited count, Packet End status will appear.



14.1.9 IR FIFO Configuration Register (FIFOCON) – Base Address + 8

Attribute: Read/Write

Size: 8 bits

BIT	7	6	5	4	3	2	1	0
NAME	TXFIFOCLR	Reserved	TX Trigger Level		RXFIFOCLR	Reserved	RX Trigger Level	
DEFAULT	0	0	0	0	0	0	0	0

BIT	DESCRIPTION
7	TX FIFO Cleared.
6	Reserved.
5~4	TX Trigger Level Bits 5 4 0 0: 31 0 1: 24 1 0: 16 1 1: 8
3	RX FIFO Cleared.
2	Reserved.
1~0	RX Trigger Level Bits 1 0 0 0: 1 0 1: 8 1 0: 16 1 1: 24

14.1.10 IR Sample RX FIFO Status Register – Base Address + 9

Attribute: Read Only

Size: 8 bits

BIT	7	6	5	4	3	2	1	0
NAME	IR_Pending	RX_GS	RX_FTA	RX_Empty	RX_Full	TX_FTA	TX_Empty	TX_Full
DEFAULT	0	0	0	0	0	0	0	0

BIT	DESCRIPTION
7	IR Pending 1: No Interrupt 0: Interrupt issue
6	Minimum Length Detect Status. This bit will be cleared when Packet End appears.



BIT	DESCRIPTION
5	RX FIFO Trigger Level Active.
4	RX FIFO Empty Flag.
3	RX FIFO Full Flag.
2	TX FIFO Trigger Level Active.
1	TX FIFO Empty Flag.
0	TX FIFO Full Flag.

14.1.11IR Sample RX FIFO Register – Base Address + A

Attribute: Read Only

Size: 8 bits

BIT	7	6	5	4	3	2	1	0
NAME	Voltage Level	Sample RX FIFO						

BIT	DESCRIPTION
7	Voltage Level 0: Low, 1: High
6~0	RX data length (Unit : Sample Period) Note: 1. 0x80 is Packet End. The hardware enters the Idle state after checking Rx Channel. 2. When 0x00 represents the glitch packet, it means pulses shorter than 3/4 sample period are received. 3. Pulses that are shorter than 1/4 sample periods will be ignored automatically.

14.1.12TX FIFO Count– Base Address + 5

Attribute: Read

Size: 8 bits

BIT	7	6	5	4	3	2	1	0
NAME	TX FIFO Count							
DEFAULT	0	0	0	0	0	0	0	0

1: Enable; 0: Disable

BIT	DESCRIPTION
7~0	TX FIFO Count

14.1.13IR Sample TX FIFO Register – Base Address + C

Attribute: Read Only

Size: 8 bits

BIT	7	6	5	4	3	2	1	0
NAME	Voltage Level Sample TX FIFO							

BIT	DESCRIPTION
7	Voltage Level 0: Low, 1: High
6~0	TX data length (Unit : Sample Period)

14.1.14IR Carrier Count High Byte Register – Base Address + D

Attribute: Read Only

Size: 8 bits

BIT	7	6	5	4	3	2	1	0
NAME	Carrier Count High Byte							

BIT	DESCRIPTION
7~0	Carrier Count High Byte. This byte records the total amount of the total rising edges until time-out event appears.

14.1.15IR Carrier Count Low Byte Register – Base Address + E

Attribute: Read Only

Size: 8 bits

BIT	7	6	5	4	3	2	1	0
NAME	Carrier Count Low Byte							

BIT	DESCRIPTION
7~0	Carrier Count Low Byte. This byte records the total amount of the the rising edges until time-out event appears.

After a time-out of reception on the learning receiver, this response is sent to tell the host the carrier frequency of the previous sample. The Carrier Count High Byte (ch) and Carrier Count Low Byte (cl) specify the cycle counts of cycles of the carrier. Carrier counts can also be thought of regarded as the number of leading edges in the previous sample.

This is used to calculate the carrier frequency as follows:

$$\text{lastCarrierCount}_{(\text{decimal})} = \text{ch} * 256 + \text{cl};$$

Thus,

$$\text{Carrier frequency} = (\text{lastCarrierCount}) / (\text{irPacketOnDuration});$$

The **irPacketOnDuration** value is the total amount of time that the envelope of the signal was high. The IR receiver should keep track of the time that of the high envelope is high and return it using this response.

This response is unsolicited. It is returned by the receiver when IR arrives but is never explicitly requested.



14.1.16IR FSM Status Register (IRFSM) – Base Address + F

Attribute: Read Only

Size: 8 bits

BIT	7	6	5	4	3	2	1	0
NAME	Reserved	Decoder FSM			Reserved	Encoder FSM		
DEFAULT	0	0	0	0	0	0	0	0

BIT	DESCRIPTION
7	Reserved.
6	Decoder over status
5	Decoder continuing status
4	Decoder wait H status 1: idle, 0: RX busy
3	Reserved.
2	Encoder Idle Status. 1: idle, 0: TX busy
1	Encoder Read Status
0	Encoder Level Output Status

14.1.17IR Minimum Length Register – Base Address + F

Attribute: Write Only

Size: 8 bits

BIT	7	6	5	4	3	2	1	0
NAME	Min Length Register							
DEFAULT	0	0	0	0	0	0	0	0

BIT	DESCRIPTION
7~0	Min Length Register. Set up the shortest expected length of each carrier on the RX receiver (Unit: Sample Clock).



15. CONSUMER INFRARED REMOTE (CIR) WAKE-UP

One of the features of the NCT6102D / NCT6106D is system boot-up by a remote controller. The hardware will store a specifically appointed key command from the IR remote controller in the FIFO of 67Byte.

The same key is required to re-boot the system after the computer shut-down. Such way can be applied to any remote controllers. Learning is necessary only at the first time.

15.1 CIR WAKE-UP Register Table

RC Block										
ExtAddr	Name	7	6	5	4	3	2	1	0	
base+0	IRCON	DEC_RST	Mode[1]	Mode[0]	RXEN	IgnoreEN	RXINV	Sample Period Select		
base+1	IRSTS	RDR	RTR	PE	RFO	GH	R	R	IR Pending	
base+2	IREN	RDR	RTR	PE	RFO	GH	R			
Base+3		FIFO_COMPARE_DEEP								
base+4		FIFO_COMPARE_TOLERANCE								
base+5		FIFO_Count								
Base+6	SLCH	Sample Limit Count High Byte								
base+7	SLCL	Sample Limit Count Low Byte								
base+8	FIFOCON	R				RXFIFOCLR	R	Rx Trigger Level		
base+9	SRXFSTS	GS	FTA	Empty	Full	R				
base+A		Sample RX FIFO								
base+B		WR_FIFO_DATA								
Base+C		Read FIFO Only								
Base+D		Read FIFO Only Index								
Base+E		FIFO_Ignore								
Base+F	IRFSM	R	Decoder FSM			R		Wakeup Event		

15.1.1 IR Configuration Register – Base Address + 0

Attribute: Read/Write

Size: 8 bits

BIT	7	6	5	4	3	2	1	0
NAME	DEC_RST	Mode[1]	Mode[0]	RXEN	Received	RXINV	Sample Period Select	
DEFAULT	0	0	1	0	0	1	1	0

BIT	DESCRIPTION
7	Reset CIR DECODER (Write 1 to clear)
6	Mode[1] : 0: FIFO can't be written 1: FIFO can be written
5	Mode[0]



BIT	DESCRIPTION
	0: Learning Mode 1: Wake up Mode (Before enter in Power S3 state, this bit should be set) This bit reset by VCC.
4	RX Enable
3	Ignore Bit Enable
2	IR Rx Invert Enable 0: Dongle Carrier ON is high, OFF (Idle) is low. 1: Dongle Carrier ON is low, OFF (Idle) is high.
1~0	Sample Period Select 00:1us, 01: 25us, 10: 50us, 11: 100us Note: In the 1us mode, the pulse mode will not function due to the IR regulations.

15.1.2 IR Status Register – Base Address + 1

Attribute: Read/Write

Size: 8 bits

BIT	7	6	5	4	3	2	1	0
NAME	RDR	RTR	PE	RFO	GH	Received		IR_Pending
DEFAULT	0	0	0	0	0	0	0	0

BIT	DESCRIPTION
7	RX Data Ready (Writing 1 will clear the bit).
6	RX FIFO Trigger Level Reach (Writing 1 will clear the bit).
5	Packet End (Writing 1 will clear the bit).
4	RX FIFO Overrun (Overrun and Data Ready will be simultaneously generated. Writing 1 will clear the bit).
3	Min Length Detected (Writing 1 will clear the bit) 1: The IR Data length received is shorter than the default value. 0: The IR Data length received is longer than the default value.
2~1	Reserved.
0	IR Pending 1: No Interrupt 0: Interrupt issue

15.1.3 IR Interrupt Configuration Register – Base Address + 2

Attribute: Read/Write

Size: 8 bits

BIT	7	6	5	4	3	2	1	0
NAME	RDR	RTR	PE	RFO	GH	Reserved		
DEFAULT	0	0	0	0	0	0	0	0

1: Enable interrupt; 0: Disable interrupt



BIT	DESCRIPTION
7	RX Data Ready
6	RX FIFO Trigger Level Reach
5	Packet End
4	RX FIFO Overrun (Overrun and Data Ready will be simultaneously generated).
3	Min Length Detected
2~0	Reserved

Note. When an Interrupt occurs, it only can be cleared by writing IR Status Register to 1.

15.1.4 IR TX Configuration Register – Base Address + 3

Attribute: Read/Write

Size: 8 bits

BIT	7	6	5	4	3	2	1	0
NAME	FIFO Compare Deep							
DEFAULT	0	1	0	0	0	0	1	1

1: Enable; 0: Disable

BIT	DESCRIPTION
7~0	When in S3 state, how many bytes need to compare. Default is 67 bytes.

15.1.5 IR FIFO Compare Tolerance Configuration Register – Base Address + 4

Attribute: Read/Write

Size: 8 bits

BIT	7	6	5	4	3	2	1	0
NAME	FIFO Compare Tolerance							
DEFAULT	0	0	0	0	0	0	0	0

BIT	DESCRIPTION
7~0	FIFO Data Tolerance between Learning mode and Wakeup mode. (Every byte) FIFO Date Tolerance = (Learning mode data) – (Wakeup mode data)

15.1.6 RX FIFO Count– Base Address + 5

Attribute: Read

Size: 8 bits

BIT	7	6	5	4	3	2	1	0
NAME	FIFO Count							
DEFAULT	0	0	0	0	0	0	0	0



1: Enable; 0: Disable

BIT	DESCRIPTION
7~0	RX FIFO Count

15.1.7 IR RX Sample Limited Count High Byte Register (RCLCH) – Base Address + 6

Attribute: Read/Write

Size: 8 bits

BIT	7	6	5	4	3	2	1	0
NAME	Sample Limited Count High Byte							
DEFAULT	0	0	0	0	0	0	0	0

BIT	DESCRIPTION
7~0	This byte is defined as the high byte of the limited count in the IR RX mode.

15.1.8 IR RX Sample Limited Count Low Byte Register (RCLCL) – Base Address + 7

Attribute: Read/Write

Size: 8 bits

BIT	7	6	5	4	3	2	1	0
NAME	Sample Limited Count low Byte							
DEFAULT	0	0	0	0	0	0	0	0

BIT	DESCRIPTION
7~0	This byte is defined as the low byte of the limited count in the IR RX mode.

Note. (RCLCH, RCLCL) is defined as 16 bits value of the limited count in the IR RX mode. When the RX data length reaches the limited count, Packet End status will appear.

15.1.9 IR FIFO Configuration Register (FIFOCON) – Base Address + 8

Attribute: Read/Write

Size: 8 bits

BIT	7	6	5	4	3	2	1	0
NAME	Reserved				RXFIFOCLR	Reserved	RX Trigger Level	
DEFAULT	0	0	0	0	0	0	0	0

BIT	DESCRIPTION
7~4	Reserved
3	RX FIFO Cleared.
2	Reserved.
1~0	RX Trigger Level Bits 1 0



0 0: 67
0 1: 66
1 0: 65
1 1: 64

15.1.10IR Sample RX FIFO Status Register – Base Address + 9

Attribute: Read Only

Size: 8 bits

BIT	7	6	5	4	3	2	1	0
NAME	GS	FTA	Empty	Full	Reserved			
DEFAULT	0	0	0	0	0	0	0	0

BIT	DESCRIPTION
7	Minimum Length Detect Status. This bit will be cleared when Packet End appears.
6	RX FIFO Trigger Level Active.
5	RX FIFO Empty Flag.
4	RX FIFO Full Flag.
3~0	Reserved

15.1.11IR Sample RX FIFO Register – Base Address + A

Attribute: Read Only

Size: 8 bits

BIT	7	6	5	4	3	2	1	0
NAME	Voltage Level	Sample RX FIFO						

BIT	DESCRIPTION
7~6	Voltage Level 0: Low, 1: High
0	RX data length (Unit : Sample Period) Note: 1. 0x80 is Packet End. The hardware enters the Idle state after checking Rx Channel. 2. When 0x00 represents the glitch packet, it means pulses shorter than 3/4 sample period are received. 3. Pulses that are shorter than 1/4 sample periods will be ignored automatically.

15.1.12Write FIFO – Base Address + B

Attribute: Write Only

Size: 8 bits

BIT	7	6	5	4	3	2	1	0
NAME	Voltage Level	Write Sample RX FIFO						



BIT	DESCRIPTION
7~6	Voltage Level 0: Low, 1: High
0	RX data length (Unit : Sample Period)

Note. Before writing FIFO Data, mode[1] register should be set.

15.1.13 Read FIFO Only – Base Address + C

Attribute: Read Only

Size: 8 bits

BIT	7	6	5	4	3	2	1	0
NAME	Voltage Level	Sample RX FIFO						

BIT	DESCRIPTION
7~6	Voltage Level 0: Low, 1: High
0	RX data length (Unit : Sample Period)

Note. Only Read FIFO Data.

15.1.14 Read FIFO Index – Base Address + D

Attribute: Read Only

Size: 8 bits

BIT	7	6	5	4	3	2	1	0
NAME	FIFO Index							

BIT	DESCRIPTION
7~0	Indicate that FIFO Index when only read FIFO data(Base Address + C)

Note. Only Read FIFO Data.

15.1.15 Reserved – Base Address + E

15.1.16 IR FSM Status Register (IRFSM) – Base Address + F

Attribute: Read Only

Size: 8 bits

BIT	7	6	5	4	3	2	1	0
NAME	Reserved	Decoder FSM			Reserved			Wakeup event
DEFAULT	0	0	0	0	0	0	0	0

15.1.17 IR Minimum Length Register – Base Address + F

Attribute: Write Only

Size: 8 bits

BIT	7	6	5	4	3	2	1	0
NAME	Min Length Register							
DEFAULT	0	0	0	0	0	0	0	0

BIT	DESCRIPTION
7~0	Min Length Register. Set up the shortest expected length of each carrier on the RX receiver (Unit: Sample Clock).

16. POWER MANAGEMENT EVENT

The PME# (pin 86) signal is connected to the South Bridge and is used to wake up the system from S1 ~ S5 sleeping states.

One control bit and four registers in the NCT6102D / NCT6106D are associated with the PME function. The control bit is at Logical Device A, CR[F2h], bit[0] and is for enabling or disabling the PME function. If this bit is set to "0", the NCT6102D / NCT6106D won't output any PME signal when any of the wake-up events has occurred and is enabled. The four registers are divided into PME status registers and PME interrupt registers of wake-up events^{Note.1}.

- 1) The PME status registers of wake-up event:
 - At Logical Device A, CR[F3h] and CR[F4h]
 - Each wake-up event has its own status
 - The PME status should be cleared by writing a "1" before enabling its corresponding bit in the PME interrupt registers
- 2) The PME interrupt registers of wake-up event:
 - At Logical Device A, CR[F6h] and CR[F7h]
 - Each wake-up event can be enabled / disabled individually to generate a PME# signal

Note.1 PME wake-up events that the NCT6102D / NCT6106D supports include:

- Mouse IRQ event
- Keyboard IRQ event
- Printer IRQ event
- Floppy IRQ event
- UART A IRQ event
- IR IRQ event
- Hardware Monitor IRQ event
- WDT1 event

Note.2 All the above support both S0 and S1 states.

16.1 Power Control Logic

This chapter describes how the NCT6102D / NCT6106D implements its ACPI function via these power control pins: PSIN# (Pin 68), PSOUT# (Pin 67), SLP_S3# (Pin 73) and PSON# (Pin 72). The following figure illustrates the relationships.

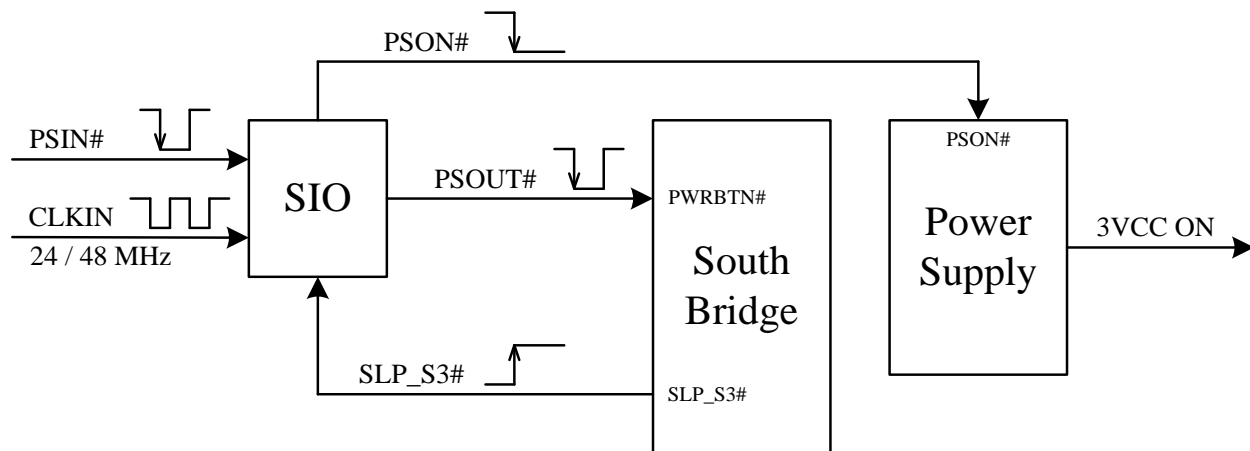

Figure 16-1 Power Control Mechanism

16.1.1 PS0N# Logic

16.1.1.1. Normal Operation

The PS0UT# signal will be asserted low if the PS0IN# signal is asserted low. The PS0UT# signal is held low for as long as the PS0IN# is held low. The South Bridge controls the SLP_S3# signal through the PS0UT# signal. The PS0N# is directly connected to the power supply to turn on or off the power.

Figure 16-2 shows the power on and off sequences.

The ACPI state changes from S5 to S0, then to S5

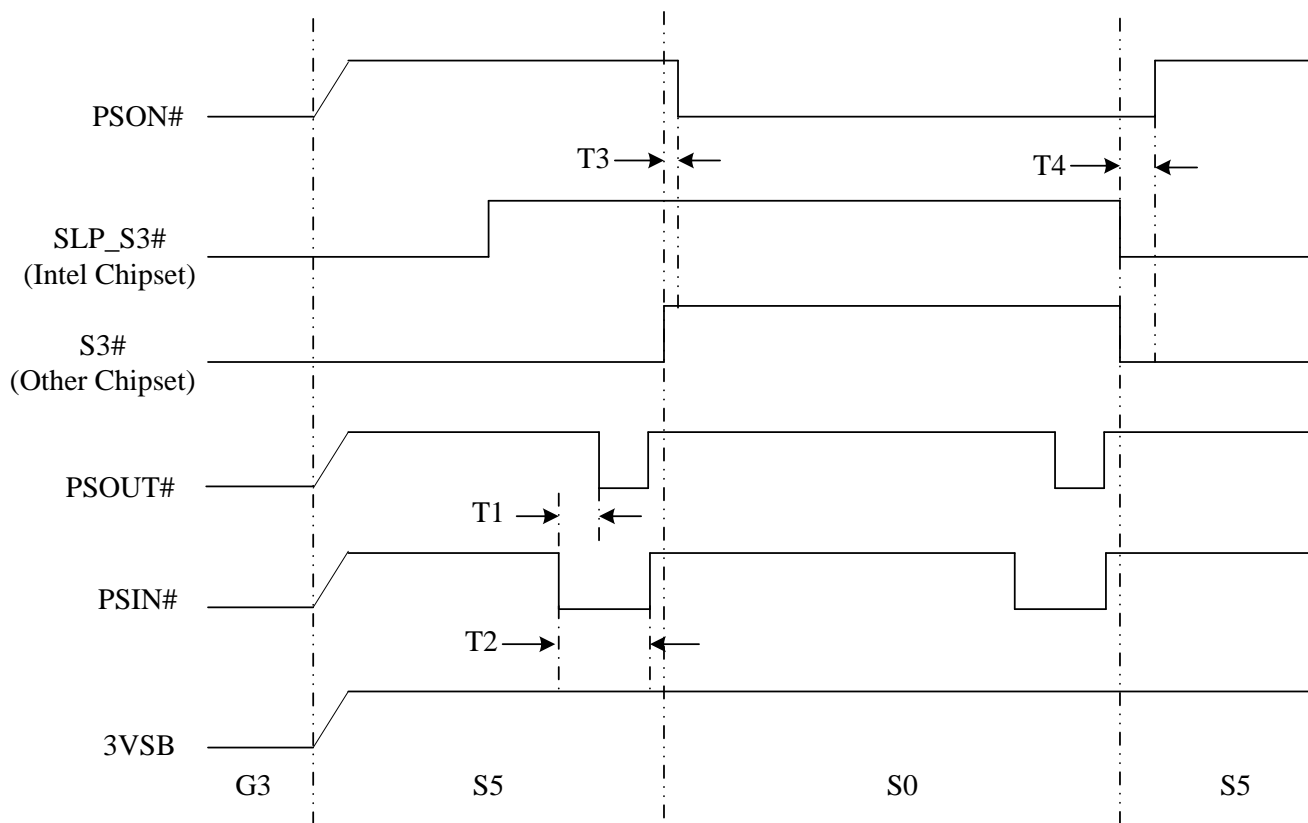

Figure 16-2 Power Sequence from S5 to S0, then Back to S5

16.1.2 AC Power Failure Resume

By definition, AC power failure means that the standby power is removed. The power failure resume control logic of the NCT6102D / NCT6106D is used to recover the system to a pre-defined state after AC power failure. Two control bits at Logical Device A, CR[E4h], bits[6:5] indicate the pre-defined state. The definition of these two bits is listed in the following table:

Table 16-1 Bit Map of Logical Device A, CR[E4h], Bits[6:5]

LOGICAL DEVICE A, CR[E4H], BITS[6 :5]	DEFINITION
00	System always turns off when it returns from AC power failure
01	System always turns on when it returns from AC power failure
10	System turns off / on when it returns from power failure depending on the state before the power failure. (Please see Note 1)
11	User defines the state before the power failure. (The previous state is set at CRE6[4]. Please see Note 2)

Note1. The NCT6102D / NCT6106D detects the state before power failure (on or off) through the SLP_S3# signal and the 3VCC power. The relation is illustrated in the following two figures.

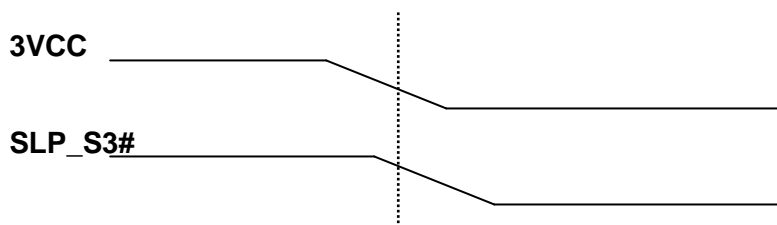

Figure 16-3 The previous state is “on”
3VCC falls to 2.6V and SLP_S3# keeps at 2.0V.

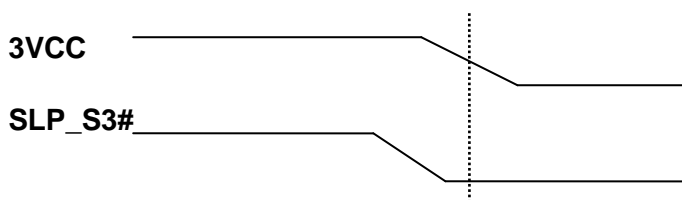

Figure 16-4 The previous state is “off”.
3VCC falls to 2.6V and SLP_S3# keeps at 0.8V.

Note 2.

Logical Device A, CR[E6h] bit [4]	Definition
0	User defines the state to be “on”
1	User defines the state to be “off”

To ensure that VCC does not fall faster than VSB in various ATX Power Supplies, the NCT6102D / NCT6106D adds the option of “user define mode” for the pre-defined state before AC power failure. BIOS can set the pre-defined state to be “On” or “Off”. According to this setting, the system is returned to the pre-defined state after the AC power recovery.

16.2 Wake Up the System by Keyboard and Mouse

The NCT6102D / NCT6106D generates a low pulse through the PSOUT# pin to wake up the system when it detects a key code pressed or mouse button clicked. The following sections describe how the NCT6102D / NCT6106D works.

16.2.1 Waken up by Keyboard events

The keyboard Wake-Up function is enabled by setting Logical Device A, CR[E0h], bit 6 to “1”.

There are two keyboard events can be used for the wake-up

- 1) Any key – Set bit 0 at Logical Device A, CR[E0h] to “1” (Default).
- 2) Specific keys (Password) – Set bit 0 at Logical Device A, CR[E0h] to “0”.

Three sets of specific key combinations are stored at Logical Device A. CR[E1h] is an index register to indicate which byte of key code storage (0x00h ~ 0x0Eh, 0x30h ~ 0x3Eh, 0x40h ~ 0x4Eh) is going to be read or written through CR[E2h]. According to IBM 101/102 keyboard specification, a complete key code contains a 1-byte make code and a 2-byte break code. For example, the make code of “0” is 0x45h, and the corresponding break code is 0xF0h, 0x45h.

The approach to implement Keyboard Password Wake-Up Function is to fill key codes into the password storage. Assume that we want to set “012” as the password. The storage should be filled as below. Please note that index 0x09h ~ 0x0Eh must be filled as 0x00h since the password has only three numbers.

Index(CRE1)→	00	01	02	03	04	05	06	07	08	09	0A	0B	0C	0D	0E
Data(CRE2)→	1E	F0	1E	16	F0	16	45	F0	45	00	00	00	00	00	00

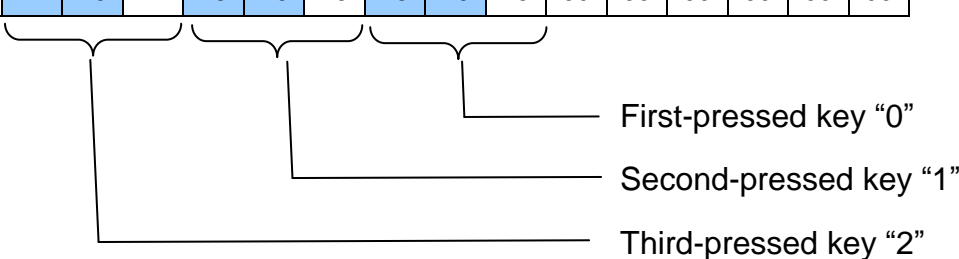

16.2.2 Waken up by Mouse events

The mouse Wake-Up function is enabled by setting Logical Device A, CR[E0h], bit 5 to “1”.

The following specific mouse events can be used for the wake-up:

- Any button clicked or any movement
- One click of the left or the right button
- One click of the left button
- One click of the right button
- Two clicks of the left button
- Two clicks of the right button.

Three control bits (ENMDAT_UP, MSRKEY, MSXKEY) define the combinations of the mouse wake-up events. Please see the following table for the details.

Table 16-2 Definitions of Mouse Wake-Up Events

ENMDAT_UP (LOGICAL DEVICE A, CR[E6H], BIT 7)	MSRKEY (LOGICAL DEVICE A, CR[E0H], BIT 4)	MSXKEY (LOGICAL DEVICE A, CR[E0H], BIT 1)	WAKE-UP EVENT
1	x	1	Any button clicked or any movement.
1	x	0	One click of the left or right button.
0	0	1	One click of the left button.
0	1	1	One click of the right button.
0	0	0	Two clicks of the left button.
0	1	0	Two clicks of the right button.

16.3 Resume Reset Logic

The RSMRST# (Pin 75) signal is a reset output and is used as the VSB power on reset signal for the South Bridge.

When the NCT6102D / NCT6106D detects the 3VSB voltage rises to “V1”, it then starts a delay – “t1” before the rising edge of RSMRST# asserting. If the 3VSB voltage falls below “V2”, the RSMRST# de-asserts immediately.

Timing and voltage parameters are shown in Figure 16-5 and Table 16-3.

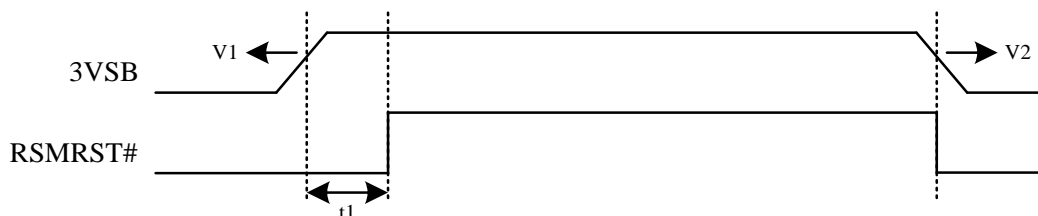

Figure 16-5 Mechanism of Resume Reset Logic

Table 16-3 Timing and Voltage Parameters of RSMRST#

NAME	PARAMETER	MIN.	MAX.	UNIT
V1	3VSB Valid Voltage	-	3.033	V
V2	3VSB Ineffective Voltage	2.882	-	V
t1	Valid 3VSB to RSMRST# inactive	200	300	mS

17. SERIALIZED IRQ

The NCT6102D / NCT6106D supports a serialized IRQ scheme. This allows a signal line to be used to report the parallel interrupt requests. Since more than one device may need to share the signal serial SERIRQ signal, an open drain signal scheme is employed. The clock source is the PCI clock. The serialized interrupt is transferred on the SERIRQ signal, one cycle consisting of three frames types: the Start Frame, the IRQ/Data Frame, and the Stop Frame.

17.1 Start Frame

There are two modes of operation for the SERIRQ Start Frame: Quiet mode and Continuous mode.

In the Quiet mode, the NCT6102D / NCT6106D drives the SERIRQ signal active low for one clock, and then tri-states it. This brings all the state machines of the NCT6102D / NCT6106D from idle to active states. The host controller (the South Bridge) then takes over driving SERIRQ signal low in the next clock and continues driving the SERIRQ low for programmable 3 to 7 clock periods. This makes the total number of clocks low 4 to 8 clock periods. After these clocks, the host controller drives the SERIRQ high for one clock and then tri-states it.

In the Continuous mode, the START Frame can only be initiated by the host controller to update the information of the IRQ/Data Frame. The host controller drives the SERIRQ signal low for 4 to 8 clock periods. Upon a reset, the SERIRQ signal is defaulted to the Continuous mode for the host controller to initiate the first Start Frame.

Please see the diagram below for more details.

Start Frame Timing with source sampled a low pulse on IRQ1.

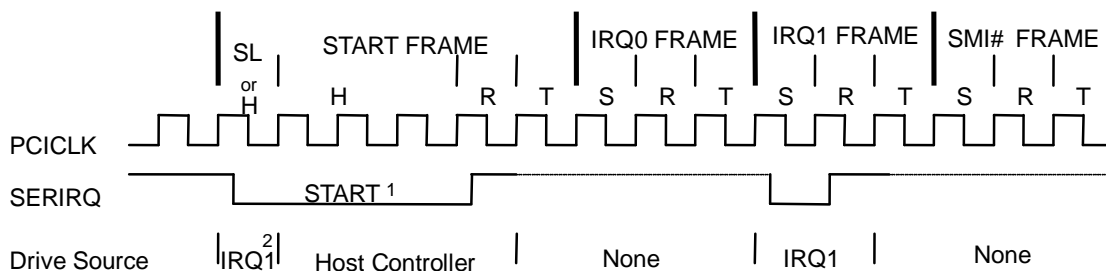

Figure 17-1 Start Frame Timing with Source Sampled A Low Pulse on IRQ1

H=Host Control

SL=Slave Control

R=Recovery

T=Turn-around

S=Sample

Note:

1. The Start Frame pulse can be 4-8 clocks wide.
2. The first clock of Start Frame is driven low by the NCT6102D / NCT6106D because IRQ1 of the NCT6102D / NCT6106D needs an interrupt request. Then the host takes over and continues to pull the SERIRQ low.



17.2 IRQ/Data Frame

Once the Start Frame has been initiated, the NCT6102D / NCT6106D must start counting frames based on the rising edge of the start pulse. Each IRQ/Data Frame has three clocks: the Sample phase, the Recovery phase, and the Turn-around phase.

During the Sample phase, the NCT6102D / NCT6106D drives SERIRQ low if the corresponding IRQ is active. If the corresponding IRQ is inactive, then SERIRQ must be left tri-stated. During the Recovery phase, the NCT6102D / NCT6106D device drives the SERIRQ high. During the Turn-around phase, the NCT6102D / NCT6106D device leaves the SERIRQ tri-stated. The NCT6102D / NCT6106D starts to drive the SERIRQ line from the beginning of "IRQ0 FRAME" based on the rising edge of PCICLK.

The IRQ/Data Frame has a specific numeral order, as shown in Table 17-1.

Table 17-1 SERIRQ Sampling Periods

SERIRQ SAMPLING PERIODS			
IRQ/DATA FRAME	SIGNAL SAMPLED	# OF CLOCKS PAST START	EMPLOYED BY
1	IRQ0	2	Reserved
2	IRQ1	5	Keyboard
3	SMI#	8	H/W Monitor & SMI
4	IRQ3	11	IR
5	IRQ4	14	UART A
6	IRQ5	17	-
7	IRQ6	20	FDC
8	IRQ7	23	LPT
9	IRQ8	26	-
10	IRQ9	29	-
11	IRQ10	32	-
12	IRQ11	35	-
13	IRQ12	38	Mouse
14	IRQ13	41	Reserved
15	IRQ14	44	-
16	IRQ15	47	-
17	IOCHCK#	50	-
18	INTA#	53	-
19	INTB#	56	-
20	INTC#	59	-
21	INTD#	62	-
32:22	Unassigned	95	-

17.3 Stop Frame

After all IRQ/Data Frames have completed, the host controller will terminate SERIRQ with a Stop frame. Only the host controller can initiate the Stop Frame by driving SERIRQ low for 2 or 3 clocks. If the Stop Frame is low for 2 clocks, the Sample mode of next SERIRQ cycle's Sample mode is the Quiet mode. If the Stop Frame is low for 3 clocks, the Sample mode of next SERIRQ cycle is the Continuous mode.

Please see the diagram below for more details.

Stop Frame Timing with Host Using 17 SERIRQ sampling period.

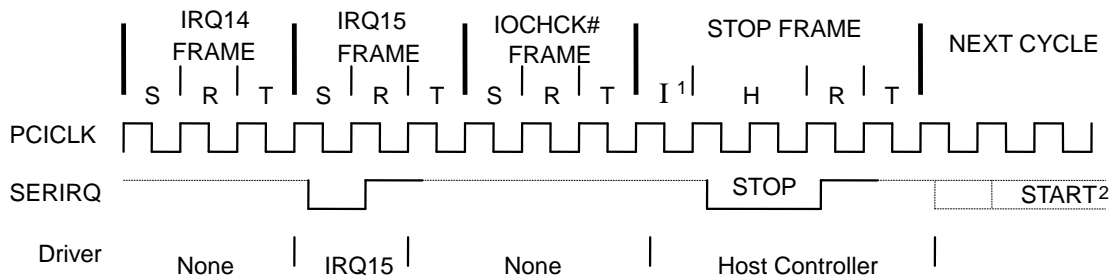

Figure 17-2 Stop Frame Timing with Host Using 17 SERIRQ Sampling Period

H=Host Control R=Recovery T=Turn-around S=Sample I= Idle.

Note:

1. There may be none, one or more Idle states during the Stop Frame.
2. The Start Frame pulse of next SERIRQ cycle may or may not start immediately after the turn-around clock of the Stop Frame.

18. WATCHDOG TIMER

The Watchdog Timer of the NCT6102D / NCT6106D consists of an 8-bit programmable time-out counter and a control and status register. GPIO0, GPIO2, GPIO3, GPIO5, GPIO6, GPIO7 provides an alternative WDT1 function. This function can be configured by the relative GPIO control register. The units of Watchdog Timer counter can be selected at Logical Device 8, CR[F0h], bit[3]. The time-out value is set at Logical Device 8, CR[F1h], default is 4. Writing zero disables the Watchdog Timer function. Writing any non-zero value to this register causes the counter to load this value into the Watchdog Timer counter and start counting down.

When Watchdog Timer 1 time-out event is occurring, GPIO0 bit[1], [5], GPIO2, bit[3], [7], GPIO3 bit[1], [5], GPIO5 bit[0], [4], GPIO6 bit[7], GPIO7 bit[0], will trigger a low pulse approx 100mS. Also the event could go to pin77 WDT0#. In other words, when the value is counted down to zero, the timer stops, and the NCT6102D / NCT6106D sets the WDT1 status bit in Logical Device 8, CR[F2h], bit[4]. Writing a zero will clear the status bit. This bit will also be cleared if LRESET# or PWROK# signal is asserted.

The Watchdog Timer 2 of the NCT6102D / NCT6106D consists of an 8-bit programmable time-out counter register (Logic Device D, CR[E2h]) and status register (Logic Device D, CR[E4h] bit7). The timeout event will trigger PWROK pin to generate a low pulse when Logic Device D, CRE3[bit0] is timer count down start bit. When Logic Device D, CRE3[bit0] set to one, the timer will start count down, until this bit is written to zero.



19. GENERAL PURPOSE I/O

19.1 GPIO ARCHITECTURE

The NCT6102D / NCT6106D provides 57 input/output ports that can be individually configured to perform a simple basic I/O function or alternative, pre-defined function. GPIO port 0 ~ 7 is configured through control registers in logical device 7. Users can configure each individual port to be an input or output port by programming respective bit in selection register (0 = output, 1 = input). Invert port value by setting inversion register (0 = non-inverse, 1 = inverse). Port value is read/written through data register.

In addition, only GP44, GP45, GP46 and GP47 are designed to be able to assert PSOUT# or PME# signal to wake up the system if any of them has any transitions. There are about 16ms debounced circuit inside these 4 GPIOs and it can be disabled by programming respective bit (LD9, CRE0h bit 4-7). Users can set what kind of event type, level or edge, and polarity, rising or falling, to perform the wake-up function. The following table gives more detailed register map on GP44, GP45, GP46 and GP47.

Table 19-1 Relative Control Registers of GPIO 44, 45, 46 and 47 that Support Wake-Up Function

	EVENTROUTE I (PSOUT#) 0: DISABLE 1: ENABLE	EVENTROUTE II (PME#) 0: DISABLE 1: ENABLE	EVENT DEBOUNCED 0 : ENABLE 1 : DISABLE	EVENT TYPE 0 : EDGE 1: LEVEL	EVENT POLARITY 0 : RISING 1 : FALLING	EVENT STATUS
GP47	LD9, CR E1h Bit7	LD9, CR E1h Bit3	LD9, CR E0h Bit7	LD9, CR E0h Bit3	LD7, CR F2h Bit7	LD7, CR F3h Bit7
GP46	LD9, CR E1h Bit6	LD9, CR E1h Bit2	LD9, CR E0h Bit6	LD9, CR E0h Bit2	LD7, CR F2h Bit6	LD7, CR F3h Bit6
GP45	LD9, CR E1h Bit5	LD9, CR E1h Bit1	LD9, CR E0h Bit5	LD9, CR E0h Bit1	LD7, CR F2h Bit5	LD7, CR F3h Bit5
GP44	LD9, CR E1h Bit4	LD9, CR E1h Bit0	LD9, CR E0h Bit4	LD9, CR E0h Bit0	LD7, CR F2h Bit4	LD7, CR F3h Bit4

Table 19-2 GPIO Group Programming Table

Equips maximum 57-pin GPIOs.

GPIO0 Group

Enable: Logic Device 7, CR30[0]

Data: Logic Device 7, E0~E3

Multi-function: YLW, GRN, WDIO#, SUSLED (Logic Device 8, CRE0[7-0])

Reset: Logic Device 9, CRE2[0]



OD/PP: Logic Device F, CRE0

Name	Pin	Default function	Default type	GPIO power plane	Switch default function to GPIO
GP00	109	GP00	input	3VSB	
GP01	110	GP01	input	3VSB	
GP02	111	GP02	input	3VSB	
GP03	112	GP03	input	3VSB	
GP04	113	GP04	input	3VSB	
GP05	114	GP05	input	3VSB	
GP06	115	GP06	input	3VSB	
GP07	116	GP07	input	3VSB	

GPIO1 Group

Enable: Logic Device 7, CR30[1]

Data: Logic Device 7, E4~E7

Multi-function: YLW, GRN, BEEP, SMI (Logic Device 8, CRE1[7-0])

Reset: Logic Device 9, CRE2[1]

OD/PP: Logic Device F, CRE1

Name	Pin	Default function	Default type	GPIO power plane	Switch default function to GPIO
GP10	117	GP10	input	3VSB	
GP11	118	GP11	input	3VSB	
GP12	119	GP12	input	3VSB	
GP13	120	GP13	input	3VSB	
GP14	121	GP14	input	3VSB	
GP15	122	GP15	input	3VSB	
GP16	123	GP16	input	3VSB	
GP17	124	GP17	input	3VSB	

GPIO2 Group

Enable: Logic Device 7, CR30[2]

Data: Logic Device 7, E8~EB

Multi-function: WDTO#, BEEP, SMI, PLED (Logic Device 8, CRE2[7-0])

Reset: Logic Device 9, CRE2[2]

OD/PP: Logic Device F, CRE2

Name	Pin	Default function	Default type	GPIO power plane	Switch default function to GPIO
GP20	125	GP20	input	3VCC	
GP21	126	GP21	input	3VCC	
GP22	127	GP22	input	3VCC	
GP23	128	GP23	input	3VCC	
GP24	01	GP24	input	3VCC	



GP25	02	GP25	input	3VCC
GP26	03	GP26	input	3VCC
GP27	04	GP27	input	3VCC

GPIO3 Group

Enable: Logic Device 7, CR30[3]

Data: Logic Device 7, EC~EF

Multi-function: BEEP, SMI, WDTO#, SUSLED (Logic Device 8, CRE3[7-0])

Reset: Logic Device 9, CRE2[3]

OD/PP: Logic Device F, CRE3

Name	Pin	Default function	Default type	GPIO power plane	Switch default function to GPIO
GP30	32	GP30	input	3VSB	
GP31	33	GP31	input	3VSB	
GP32	34	GP32	input	3VSB	
GP33	35	GP33	input	3VSB	
GP34	36	GP34	input	3VSB	
GP35	37	GP35	input	3VSB	
GP36	38	GP36	input	3VSB	
GP37	39	GP37	input	3VSB	

GPIO4 Group

Enable: Logic Device 7, CR30[4]

Data: Logic Device 7, F0~F3

Multi-function: YLW, GRN, PLED, SMI (Logic Device 8, CRE4[7-0])

Reset: Logic Device 9, CRE2[4]

OD/PP: Logic Device F, CRE4

Name	Pin	Default function	Default type	GPIO power plane	Switch default function to GPIO
GP40	40	GP40	input	3VSB	
GP41	41	GP41	input	3VSB	
GP42	42	GP42	input	3VSB	
GP43	43	GP43	input	3VSB	
GP44	44	GP44	input	3VSB	
GP45	45	GP45	input	3VSB	
GP46	46	GP46	input	3VSB	
GP47	47	GP47	input	3VSB	

GPIO5 Group

Enable: Logic Device 7, CR30[5]

Data: Logic Device 7, F4~F7

Multi-function: YLW, GRN, BEEP, WDTO# (Logic Device 8, CRE5[7-0])

Reset: Logic Device 9, CRE2[5]

OD/PP: Logic Device F, CRE5

Name	Pin	Default function	Default type	GPIO power plane	Switch default function to GPIO
GP50	62	KCLK	bi-direction	3VSB	
GP51	63	KDAT	bi-direction	3VSB	



GP52	65	MCLK	bi-direction	3VSB	
GP53	66	MDAT	bi-direction	3VSB	
GP54	67	PSOUT#	output	3VSB	
GP55	68	PSIN#	input	3VSB	
GP56	70	SLP_S5#	input	3VSB	
GP57	71	PWROK	output (OD)	VRTC	

GPIO6 Group

Enable: Logic Device 7, CR30[6]

Data: Logic Device 7, F8~FB

Multi-function: YLW, GRN, BEEP, SMI, WDTO#, SUSLED, PLED (Logic Device 8, CRE6[7-0])

Reset: Logic Device 9, CRE2[6]

OD/PP: Logic Device F, CRE6

Name	Pin	Default function	Default type	GPIO power plane	Switch default function to GPIO
GP60	72	PSON#	output	3VSB	
GP61	73	SLP_S3#	input	3VSB	
GP62	75	RSMRST#	output	3VSB	
GP63	94	SDA	input	3VSB	
GP64	96	SCL	input	3VSB	
GP65	106	SUSLED	output	3VSB	
GP66	107	GP66	input	3VSB	
GP67	108	GP67	input	3VSB	

GPIO7 Group

Enable: Logic Device 7, CR30[6]

Data: Logic Device 7, FC~FF

Multi-function: YLW, GRN, BEEP, SMI, WDTO#, SUSLED, PLED (Logic Device 8, CRE7[7-0])

Reset: Logic Device 9, CRE2[7]

OD/PP: Logic Device F, CRE7

Name	Pin	Default function	Default type	GPIO power plane	Switch default function to GPIO
GP71	87	GP71	Input	3VSB	



Table 19-3 GPIO Multi-Function Routing Table

GPIO Multi-Function Routing							
Bit	GPIO0	GPIO1	GPIO2	GPIO3	GPIO4	GPIO5	GPIO6
7	0: GPIO07 1: YLW	0: GPIO17 1: YLW	0: GPIO27 1: WDTO#	0: GPIO37 1: BEEP	0: GPIO47 1: YLW	0: GPIO57 1: YLW	
6	0: GPIO06 1: GRN	0: GPIO16 1: GRN	0: GPIO26 1: BEEP	0: GPIO36 1: SMI	0: GPIO46 1: GRN	0: GPIO56 1: GRN	0: GPIO66 1: YLW
5	0: GPIO05 1: WDTO#	0: GPIO15 1: BEEP	0: GPIO25 1: SMI	0: GPIO35 1: WDTO#	0: GPIO45 1: PLED	0: GPIO55 1: BEEP	0: GPIO65 1: GRN
4	0: GPIO04 1: SUSLED	0: GPIO14 1: SMI	0: GPIO24 1: PLED	0: GPIO34 1: SUSLED	0: GPIO44 1: SMI	0: GPIO54 1: WDTO#	0: GPIO64 1: BEEP
3	0: GPIO03 1: YLW	0: GPIO13 1: YLW	0: GPIO23 1: WDTO#	0: GPIO33 1: BEEP	0: GPIO43 1: YLW	0: GPIO53 1: YLW	0: GPIO63 1: SMI
2	0: GPIO02 1: GRN	0: GPIO12 1: GRN	0: GPIO22 1: BEEP	0: GPIO32 1: SMI	0: GPIO42 1: GRN	0: GPIO52 1: GRN	0: GPIO62 1: WDTO#
1	0: GPIO01 1: WDTO#	0: GPIO11 1: BEEP	0: GPIO21 1: SMI	0: GPIO31 1: WDTO#	0: GPIO41 1: PLED	0: GPIO51 1: BEEP	0: GPIO61 1: SUSLED
0	0: GPIO00 1: SUSLED	0: GPIO10 1: SMI	0: GPIO20 1: PLED	0: GPIO30 1: SUSLED	0: GPIO40 1: SMI	0: GPIO50 1: WDTO#	0: GPIO60 1: PLED

Bit	GPIO6	GPIO7
7	000: GPIO67 001: YLW 001: GRN 001: BEEP 001: SMI 001: WDTO# 001: SUSLED 001: PLED	
1		0: GPIO71 1: WDTO#

19.2 ACCESS CHANNELS

There are two different channels to set up/access the GPIO ports. The first one is the indirect access via register 2E/2F (4E/4F, it depends by HEFRAS trapping). The registers can be read / written only when the respective logical device ID and port number are selected.

The other is the direct access through GPIO register table that can be configured by {CR61, CR60} of logic device 8. The mapped 7 registers are defined in table 19-4. Base address plus 0 to 4 are GPIO registers, base address plus 5 and 6 are watchdog registers. Since the base address is set, the GPIO number can be selected by writing the group number to GSR [INDEX] (GPIO Select Register, #0~#7 for GPIO0 ~ GPIO7 respectively). Then the I/O register, the Data register and the Inversion register are mapped to addresses Base+0, Base+1 and Base+2 respectively. Only one GPIO can be accessed at one time.

Table 19-4 GPIO Register Addresses

ADDRESS	ABBR	BIT NUMBER							
		7	6	5	4	3	2	1	0
Base + 0	GSR	Reserved				INDEX			
Base + 1	IOR	GPIO I/O Register							
Base + 2	DAT	GPIO Data Register							
Base + 3	INV	GPIO Inversion Register							
Base + 4	DST	GPIO Status Register							
Base + 5	Wdtmod	Watchdog Timer I (WDT1) and KBC P20 Control Mode Register							
Base + 6	Wdttim	Watchdog Timer I (WDT1) Control Register							

20. SMBUS MASTER INTERFACE

20.1 General Description

The SMBus interface module is two wire serial interface compatible to the SMBus physical layer. It is also compatible with Intel's SMBus and Philips' I²C bus.

The rest of this section introduces the various features of the SMBus master capability. These features are divided into the following sections:

- ◆ SMBus and I²C compliant
- ◆ AMD-TSI
- ◆ PCH
- ◆ SMBus master

20.2 Introduction to the SMBus Master

20.2.1 Data Transfer Format

Every byte transferred on the bus consists of 8 bits. After the start condition, the master places the 7-bit address to the slave device it wants to address on the bus. The address followed an eight bit indicating the direction of the data transfer (R/W#); a zero indicates a transmission for data while a one indicates a request for data. Each byte is transferred with the most significant bit first, and after each byte, an acknowledge signal must follow. A data transfer is always terminated by stop condition generated by master.

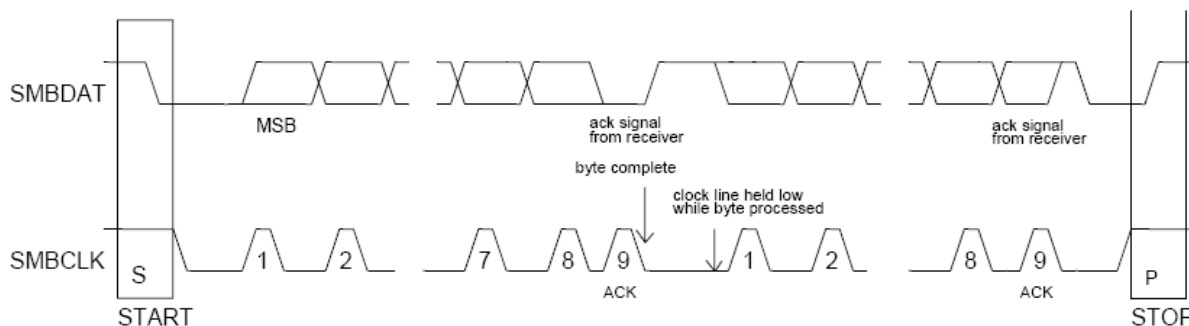

Figure 20-1 Data Transfer Format

20.2.2 Arbitration

Arbitration takes place on the SMBDAT data line while the SMBCLK line is high. Two devices may generate a start condition at the same time and enter the arbitration procedure. Arbitration continues until one master generates a HIGH level on the SMBDAT line while another competing master generates a LOW level on the SMBDAT line while SMBCLK is high. The master device which generated the HIGH level on SMBDAT loses arbitration. If a device loses arbitration during the first byte following a start condition i.e. while transmitting a slave address it becomes a slave receiver and monitors the address for a potential match. Arbitration may also be lost in the master receive mode during the acknowledge cycle.

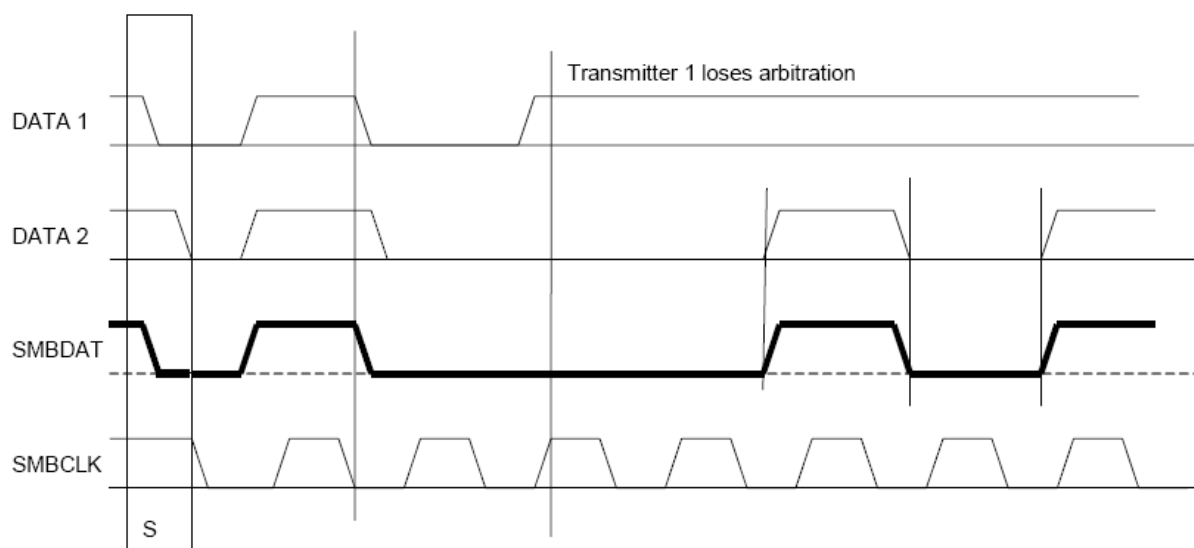

Figure 20-2 SMBus Arbitration

20.2.3 Clock Synchronization

Clock synchronization is performed while the arbitration procedure described above is in effect. Clock Synchronization takes place between two competing devices by utilizing the wired-AND nature of the SMBCLK line. The SMBCLK line will go low as soon as the master with the shortest high time pulls SMBCLK low. SMBCLK will remain low until the device with the longest SMBCLK low time relinquishes the SMBCLK line. Therefore the SMBCLK high time is determined by device with the shortest high time while the SMBCLK low time is determined by the device with the longest low time.

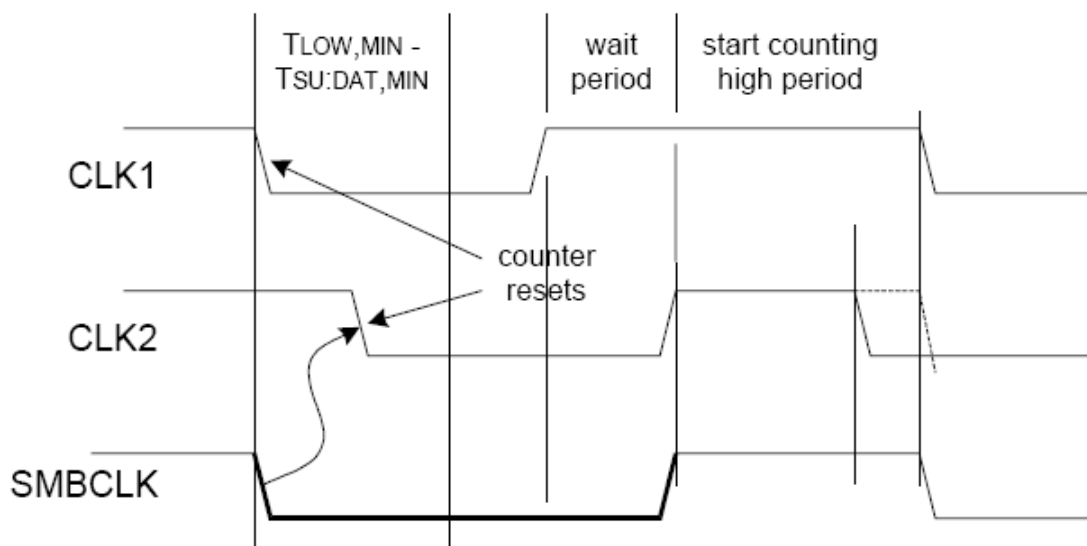

Figure 20-3 Clock synchronization



20.3 SB-TSI

The combined-format repeated start sequence is not supported in standard-mode and fast-mode.

- ◆ Only 7-bit SMBus addresses are supported.
- ◆ SB-TSI implements the Send/Receive Byte and Read/Write Byte protocols.
- ◆ SB-TSI registers can only be written using a write byte command.
- ◆ Address Resolution Protocol (ARP) is not implemented.
- ◆ Packet Error Checking (PEC) is not supported.

20.3.1 SB-TSI Address

The SMBus address is really 7 bits. The SB-TSI address is normally 98h or 4Ch. The address could vary with address select bits.

Table 20-1 SB-TSI Address Encoding

Address Select Bits	SB-TSI Address
000b	98h
001b	9Ah
010b	9Ch
011b	9Eh
100b	90h
101b	92h
110b	94h
111b	96h

20.4 PCH

The PCH provide system thermal data to EC. The EC can manage the fans and other cooling elements based on this data. A subset of the thermal collection is that the PCH and be programmed to alert the EC when a device has gone outside of its temperature limits.

20.4.1 Command Summary

Table 20-2 PCH Command Summary

Trans-action	Slave Addr.	Data Byte 0 =Command	Data Byte 1 =Byte Count	Data Byte 2	Data Byte 3	Data Byte 4	Data Byte 5	Data Byte 6	Data Byte 7
Write STS Preferences	I2C	0x41	0x6	STS [47:40]	STS [39:32]	STS [31:24]	STS [23:16]	STS [15:8]	STS [7:0]
Write CPU Temp Limits	I2C	0x42	0x6	Lower Limit [15:8]	Lower Limit [7:0]	Upper Limit [15:8]	Upper Limit [15:8]		
Write MCH	I2C	0x43	0x2	Lower	Upper	na	na		

Trans-action	Slave Addr.	Data Byte 0 =Command	Data Byte 1 =Byte Count	Data Byte 2	Data Byte 3	Data Byte 4	Data Byte 5	Data Byte 6	Data Byte 7
Temp Limits				Limit [7:0]	Limit [7:0]				
Write IBX Temp Limits	I2C	0x44	0x2	Lower Limit [7:0]	Upper Limit [7:0]	na	na		
Write DIMM Temp Limits	I2C	0x45	0x2	Lower Limit [7:0]	Upper Limit [7:0]	na	na		
Write MPC CPU Power Clamp	I2C	0x50	0x2	Lower Limit [7:0]	Power Clamp [7:0]				
Block Read	Block Read Address	0x40	Block Read Address	Byte Count	Data 0	Data N	PEC (optional)		

20.5 SMBus Master

20.5.1 Block Diagram

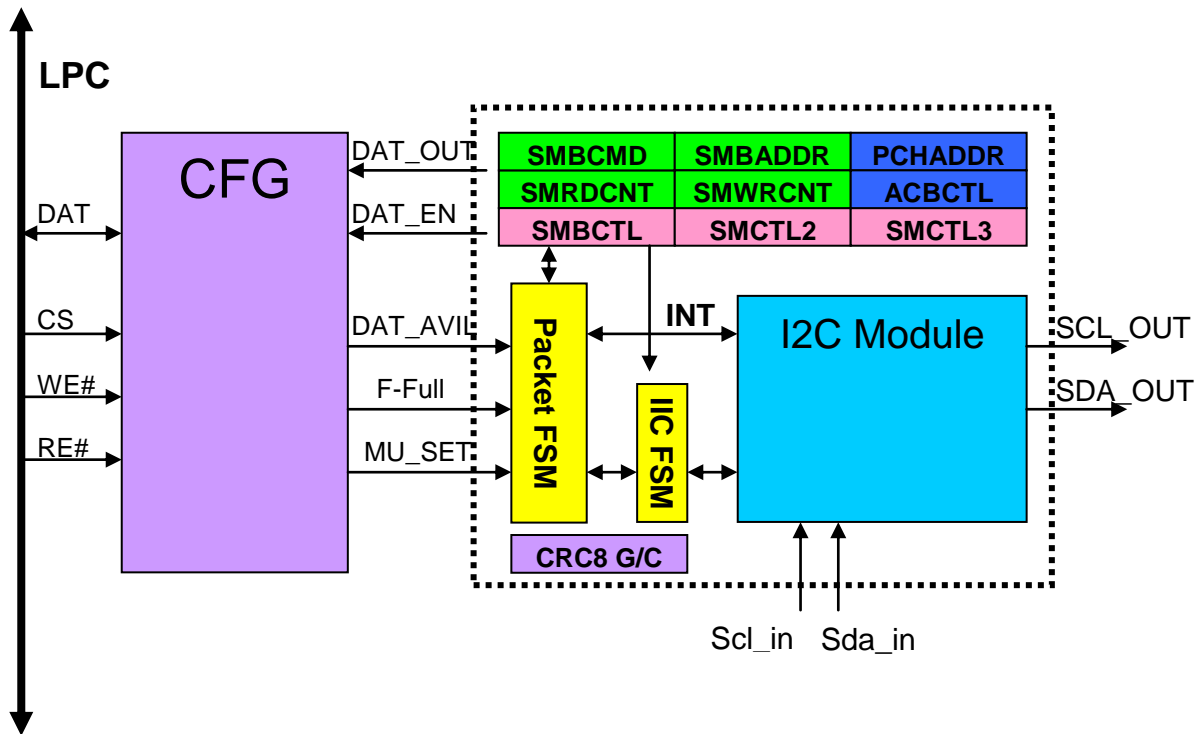

Figure 20-4 SMBus Master Block Diagram

20.5.2 Programming Flow

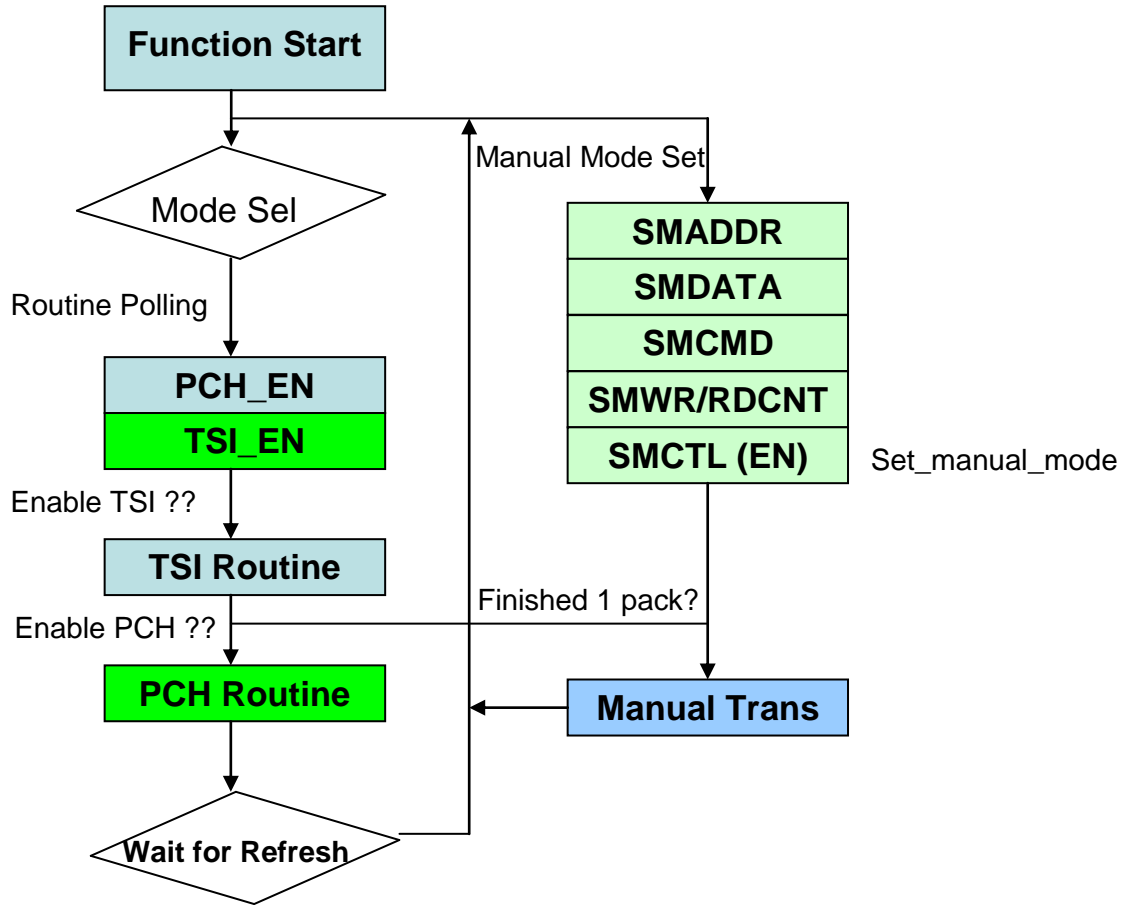

Figure 20-5 Programming Flow

20.5.3 TSI Routine

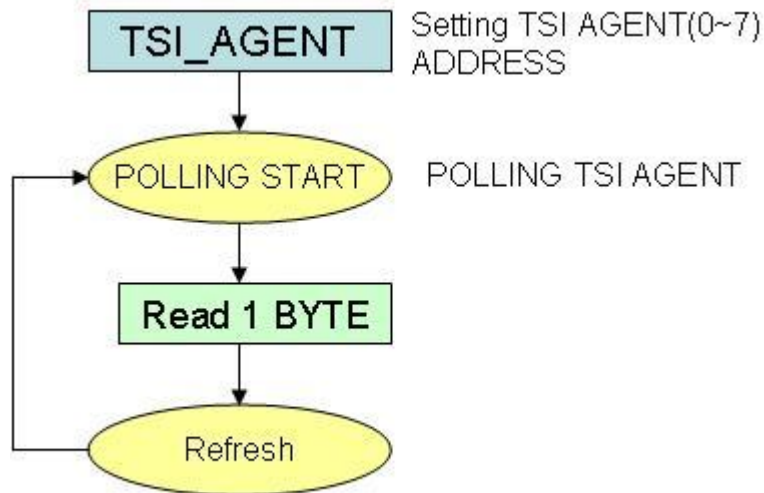

Figure 20-6 TSI Routine

20.5.4 PCH Routine

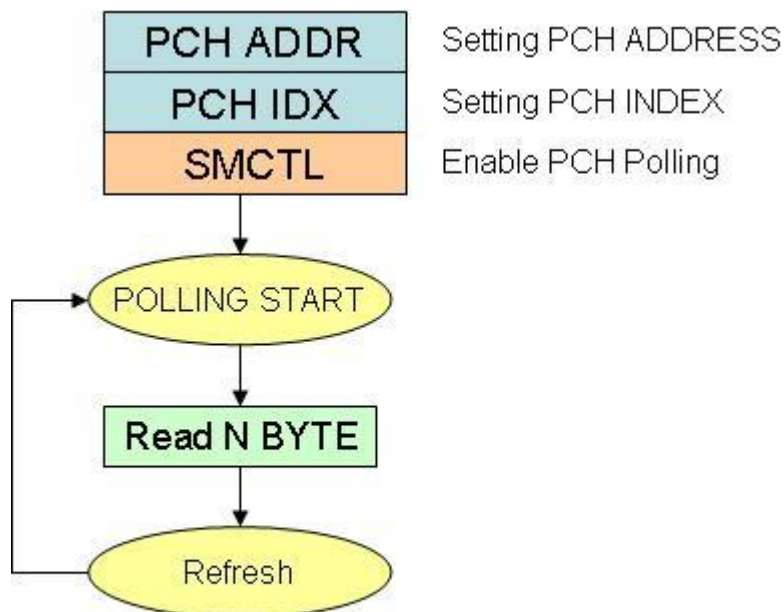

Figure 20-7 PCH Routine

20.5.5 BYTE Rutine

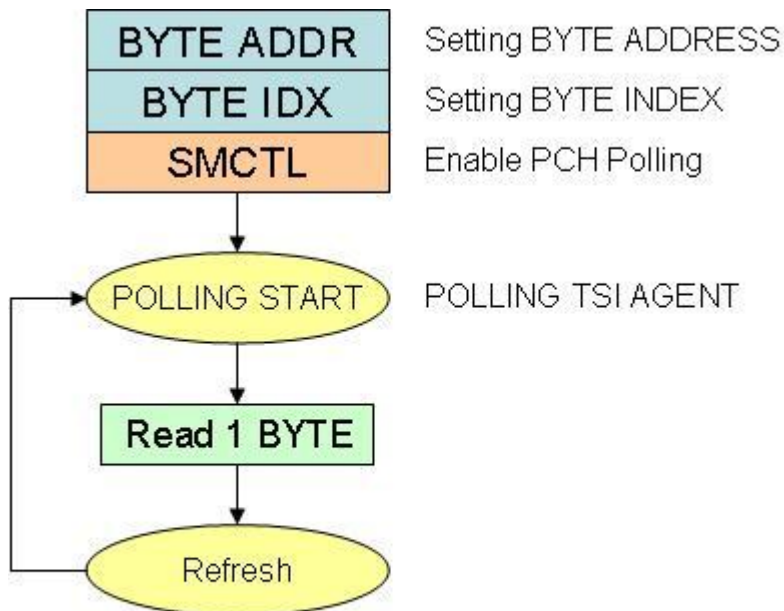

Figure 20-8 PCH Routine

20.5.6 Manual Mode interface

The SMBus host supports Block/Word/Byte Write and Block/Word/Byte read with PEC. The SMBus host can use the interface to access the smbus slave. The timing diagrams below illustrate how to use the smbus interface to write the data or read the data to the smbus slave.

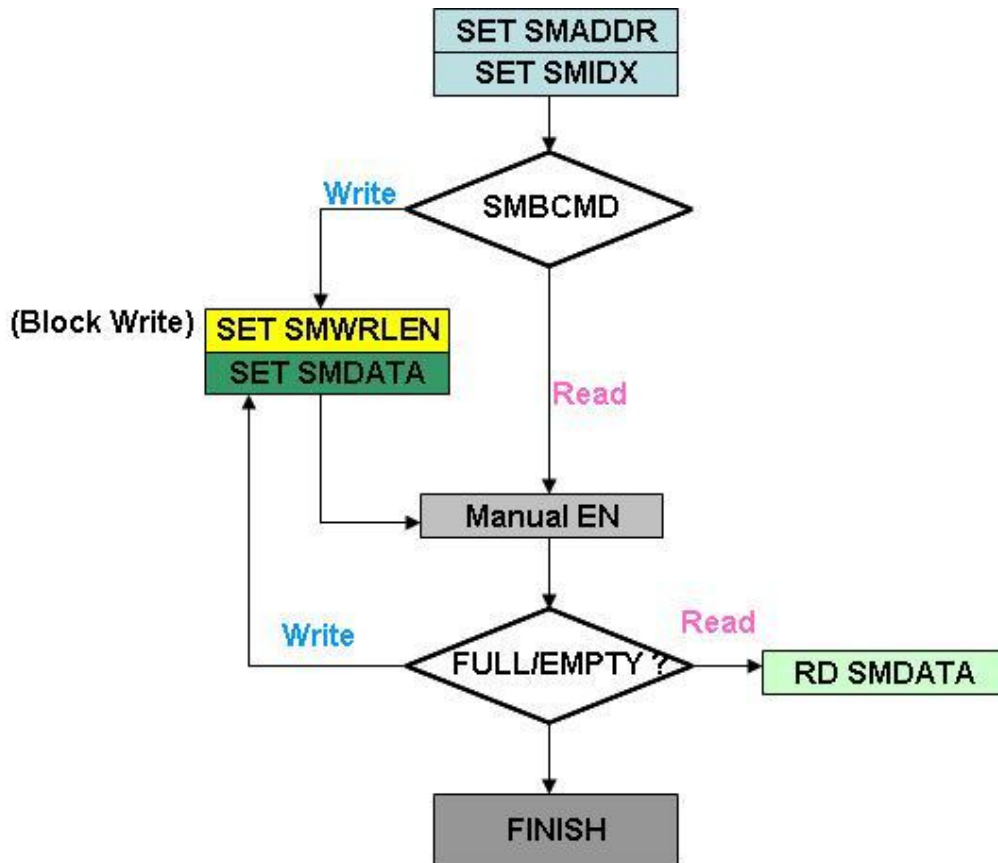

Figure 20-9 Manual Mode Programming Flow

20.6 Register Type Abbreviations

The following abbreviations are used to indicate the Register Type:

- ◆ R/W = Read/Write.
- ◆ R = Read from register.
- ◆ W = Write.
- ◆ RO = Read-only.

To program the SMBus master configuration registers, the following configuration procedures must be followed in sequence:

- (1). Enter the Extended Function Mode.
- (2). Configure the configuration registers.

20.6.1 Enter the Extended Function Mode

To place the chip into the Extended Function Mode, two successive writes of 0x26 must be applied to Extended Function Enable Registers (EFERs, i.e. 2Eh or 4Eh).

20.6.2 Configure the Configuration Registers

The chip selects the Logical Device and activates the desired Logical Devices through Extended Function Index Register (EFIR) and Extended Function Data Register (EFDR). The EFIR is located at the same address as the EFER, and the EFDR is located at address (EFIR+1).

First, write the Logical Device Number (i.e. 0x07) to the EFIR and then write the number of the desired Logical Device to the EFDR. If accessing the Chip (Global) Control Registers, this step is not required.

Secondly, write the address of the desired configuration register within the Logical Device to the EFIR and then write (or read) the desired configuration register through the EFDR.

20.7 SMBus Master Register Set

20.7.1 SMBus Register Map

SMBus Master base address in register Logic Device B CR62h(MSB), CR63h(LSB).

Table 20-3 SMBus Master Bank 0 Registers

Offset	Type	Name	Section
0	R/W	SMDATA	25.7.2
1	R/W	SMWRSIZE	25.7.3
2	R/W	SMBCMD	25.7.4
3	R/W	SMIDX	25.7.5
4	R/W	SMCTL	25.7.6
5	R/W	SMADDR	25.7.7
6	R/W	SCLFREQ	25.7.8
7	RO	Reserved	--
8	R/W	PCHADDR	25.7.10
9	R/W	Error_status	25.7.11
A	R/W	Reserved	--
B	R/W	PCHCMD	25.7.13
D	R/W	TSI_AGENT	--
E	R/W	SMCTL3	25.7.15
F	R/W	SMCTL2	25.7.15
10	R/W	BYTE_ADDR	
11	R/W	BYTE_IDX_H	
12	R/W	BYTE_IDX_L	
13	R/W	Reserved	
14	R/W	Reserved	



20.7.2 SMBus Data (SMDATA) – Bank 0

This 32 bits register is the data in and out register of SMBus data register. Before writing to SMDATA register, this register contains the input data, after writing to SMDATA register, this register contains the output data.

Offset: 0h

Type: R/W

Byte	3	2	1	0
Name	SMFIFO3	SMFIFO2	SMFIFO1	SMFIFO0
Default	00h	00h	00h	00h

Byte	Description
3	SMFIFO3 (SMBus FIFO 3) . This byte represents the high byte of the 32 bits SMBus data.
2	SMFIFO2 (SMBus FIFO 2) . This byte represents the second byte of the 32 bits SMBus data.
1	SMFIFO1 (SMBus FIFO 1) . This byte represents the first byte of the 32 bits SMBus data.
0	SMFIFO0 (SMBus FIFO 0) . This byte represents the low byte of the 32 bits SMBus data.

20.7.3 SMBus Write Data Size (SMWRSIZE) – Bank 0

Offset: 1h

Type: R/W

Bit	7	6	5	4	3	2	1	0
Name	Reserved			SMWRSIZE				
Default	0	0	0	0	0	0	0	0

Bit	Description
7-5	Reserved.
4-0	SMWRSIZE (SMBus Write Byte Counter) . This field sets the write byte counter, the max counter size is 32 bytes, and the minimal size is 1 bytes.

20.7.4 SMBus Command (SMCMD) – Bank 0

Offset: 2h

Type: R/W

Bit	7	6	5	4	3	2	1	0
NAME	REV				SMBus CMD			
Default	0	0	0	0	0	0	0	0

Bit	Description
7-4	Reserved.
3-0	SMBCMD (SMBus Command). This field sets SMBus Command: 0000 : Read Byte (Default) 0001 : Read Word 0010 : Read Block 0011 : Block Write and Read Process Call 0100 : Process Call 1000 : Write Byte 1001 : Write Word 1010 : Write Block

20.7.5 SMBus INDEX (SMIDX) – Bank 0

Offset: 3h

Type: R/W

Bit	7	6	5	4	3	2	1	0
Name	SMCMD							
Default	0	0	0	0	0	0	0	0

Bit	Description
7-0	SMIDX (SMBus INDEX). This field represents the index data of the SMBus.

20.7.6 SMBus Control (SMCTL) – Bank 0

Offset: 4h

Type: R/W

Bit	7	6	5	4	3	2	1	0
Name	MMODE_S	S_RST	CRC8_EN	REFLASH_CLK			BYTE_EN	PCH_EN
Default	0	0	0	0	0	0	0	0

Bit	Description
7	MMODE_S (Manual Mode Set). 0 : Disable. 1 : Enable.
6	S_RST (Soft Reset SMBus). 0 : Disable. 1 : Enable.



Bit	Description
5	CRC8_EN (CRC8 Enable). 0 : CRC8 function is disable. 1 : CRC8 function is enable.
4-2	REFRASH_CLK (Refresh Clock Select). 000, 100 – 128ms 001, 101 – 256ms 010, 110 – 512ms 011, 111 – 64ms (1KHz)
1	BYTE_EN (BYTE Enable). 0 : BYTE function is disable. 1 : BYTE function is enable.
0	PCH_EN (PCH Enable). 0 : PCH function is disable. 1 : PCH function is enable.

20.7.7 SMBus Address (SMADDR) – Bank 0

Offset: 5h

Type: R/W

Bit	7	6	5	4	3	2	1	0
Name	SMADDR							REV
Default	0	0	0	0	0	0	0	0

Bit	Description
7-1	SMADDR (SMBus Address). AMD-TSI only supports 7-bit SMBus address.
0	Reserved: 0 : Write. If the protocol is write, the WR_SIZE can't be zero. (Default)

20.7.8 SCL FREQ (SCLFREQ) – Bank 0

Offset: 6h

Type: R/W

Bit	7	6	5	4	3	2	1	0
	Reserved:				SCLFREQ			
Default	0	0	0	0	0	1	1	1



Bit	Description
7-4	Reserved
3-0	<p>SCLFQ (SMBCLK Frequency). This field defines the SMBCLK period (low time and high time). The clock low time and high time ate defined as follows:</p> <p>0000 : 365KHz 0001 : 261KHz 0010 : 200KHz 0011 : 162KHz 0100 : 136KHz 0101 : 117KHz 0110 : 103KHz 0111 : 91.5KHz (Default) 1000 : 83KHz 1001 : 76KHz 1010 : 70KHz 1011 : 65KHz 1100 : 61KHz 1101 : 57KHz 1110 : 53KHz 1111 : 47KHz</p>

20.7.9 PCH Address (PCHADDR) – Bank 0

Offset: 8h

Type: R/W

Bit	7	6	5	4	3	2	1	0
Name	PCHADDR							REV
Default	1	0	0	1	0	1	0	0

Bit	Description
7-1	<p>PCHADDR (PCH Address). PCH supports 8-bit SMBus address. The default address is 94h. The last bit is read or write bit. It needs to set to “0”.</p>

20.7.10SMBus Error Status (Error_status) – Bank 0

Offset: 9h

Type: RO/W1C

Bit	7	6	5	4	3	2	1	0
Name	REV	ADNACK	Timeout	Reserved	BER	NACK	Reserve	
Default	1	0	0	1	0	1	0	0

Bit	Description
7-6	Reserved.
5	ADDR Non ACK. This bit reflects SMBus occurred ADDRESS NON ACK in Manual mode..
4	Timeout. This bit reflects when SMBus occurs timeout.
3	Reserved.
2	BER (Bus Error). This bit reflects when a start or stop condition is detected during data transfer, or when an arbitration problem is detected.
1	NACK (Negative acknowledge). This bit is set by hardware when a transmission is not acknowledged on the ninth clock. While NACK is set SCL will be drive low and subsequent bus transactions are stalled until NACK is cleared.
0	Reserved.

20.7.11 PCH Command (PCHCMD) – Bank 0

Offset: bh

Type: R/W

Bit	7	6	5	4	3	2	1	0
Name	PCHCMD							
Default	0	1	0	0	0	0	0	0

Bit	Description
7-0	PCHCMD (PCH Command). This field represents the command data of the PCH. The default command is block read (40h).

20.7.12 TSI Agent Enable Register (TSI_AGENT) – Bank

Offset: dh

Type: RO

Bit	7	6	5	4	3	2	1	0
Name	AG7	AG6	AG5	AG4	AG3	AG2	AG1	AG0
Default	0	0	0	0	0	0	0	0

Bit	Description
7	TSI_AGENT7 Enable. : This bit reflects AMD-TSI Agent enable. 0 : Diable
6	TSI_AGENT6 Enable. : This bit reflects AMD-TSI Agent enable. 0 : Diable
5	TSI_AGENT5 Enable. : This bit reflects AMD-TSI Agent enable. 0 : Diable



Bit	Description
4	TSI AGENT4 Enable. : This bit reflects AMD-TSI Agent enable. 0 : Disable
3	TSI AGENT3 Enable. : This bit reflects AMD-TSI Agent enable. 0 : Disable
2	TSI AGENT2 Enable. : This bit reflects AMD-TSI Agent enable. 0 : Disable
1	TSI AGENT1 Enable. : This bit reflects AMD-TSI Agent enable. 0 : Disable 1 : Full
0	TSI AGENT0 Enable. : This bit reflects AMD-TSI Agent enable. 0 : Disable 1 : Empty

20.7.13 SMBus Control 3 Register (SMCTL3) – Bank 0

Offset: eh

Type: RO

Bit	7	6	5	4	3	2	1	0
Name	Reserved				CRC_CHK	M_MODE	F_FULL	F_EMPT
Default	0	0	0	0	0	0	0	0

Bit	Description
7-4	Reserved
3	CRC_CHK (CRC Check). 0 : incorrect 1 : correct
2	M_MODE (Manual Mode). 0 : Non-active 1 : Active
1	F_FULL (fifo_full). : This bit reflects SMBus data fifo is full. 0 : Non-full 1 : Full
0	F_EMPT (fifo empty). : This bit reflects the SMBus data fifo is empty. 0 : Non-empty 1 : Empty

20.7.14 SMBus Control 2 Register (SMCTL2) – Bank 0

Offset: fh

Type: R/W

Bit	7	6	5	4	3	2	1	0
Name	Reserved		INT_LCH_E	Reserved		BYTE_SEL	BANKSEL	
Default	0	0	0	0	0	0	0	0

Bit	Description
7-6	Reserved.
5	INT_LCH_E (Interrupt Latch Enable). : This bit will latch the I2CSTA register. 0 : Disable. 1 : Enable.
2	BYTE_SEL :This field represents byte polling 8-bit/16bit select bits. 0: BYTE_TEMP is 16 bit data 1: BYTE_TEMP is 8 bit data
1-0	BANKSEL (Bank Select). 00 – Bank 0. 01 – Bank 1. 10 – Bank 2.

20.7.15 BYTE ADDRESS (BYTE ADDR) – Bank 0

Offset: 10h

Type: R/W

Bit	7	6	5	4	3	2	1	0
Name	BYTE_ADDRESS							
Default	0	1	0	0	0	0	0	0

Bit	Description
7-0	BYTE ADDRESS (BYTE ADDR). This field represents the address data of the BYTE.

20.7.16 BYTE INDEX_H (BYTE_IDX_H) – Bank 0

Offset: 11h

Type: R/W

Bit	7	6	5	4	3	2	1	0
Name	BYTE_IDX_H							
Default	0	0	0	0	0	0	0	1

Bit	Description
7-0	BYTE_IDX_H (High BYTE INDEX). This field represents the high byte index of the Byte polling. The default command is byte read (01h).

20.7.17 BYTE INDEX_L (BYTE_IDX_L) – Bank 0

Offset: 12h

Type: R/W

Bit	7	6	5	4	3	2	1	0
Name	BYTE_IDX_L							
Default	0	0	0	1	0	0	0	0

Bit	Description
7-0	BYTE_IDX_L (LOW BYTE INDEX). This field represents the low byte index of the Byte polling. The default command is byte read (10h).

The EC may read thermal information from IBX using the SMBus block read command. The IBX doesn't support byte-read or word-read SMBus commands. The read use a different address that the writes. The address must be different so that the IBX knows which target is intended, either the I2C target or the block read buffer.

The IBX and EC are set up by BIOS with the length of the read that is supported by the platform. The EC must always do reads of the lengths set up by BIOS. There is no way to change the length of the read after BIOS has set things up.

An EC that only wants the single highest temperature among MCH, and CPU could read one byte. A 2 byte read would provide both IBX and CPU/MCH package temperature. An EC that wanted each components temperature would do a 4 byte read. An EC that also wanted DIMM information would read 9 bytes. If an EC wanted to read the HOST STS status, it must read 19 bytes. An EC can also read the energy data provided by the CPU by reading 12 bytes.

21. FADING LED

21.1 FADING LED DESCRIPTION

The NCT6102D / NCT6106D provides Fading led interface that can be changed led speed of bright or dark through different frequency or duty cycle. Furthermore, the contrast of led bright or dark can be decided by maximum duty cycle, minimum duty cycle, and middle value.

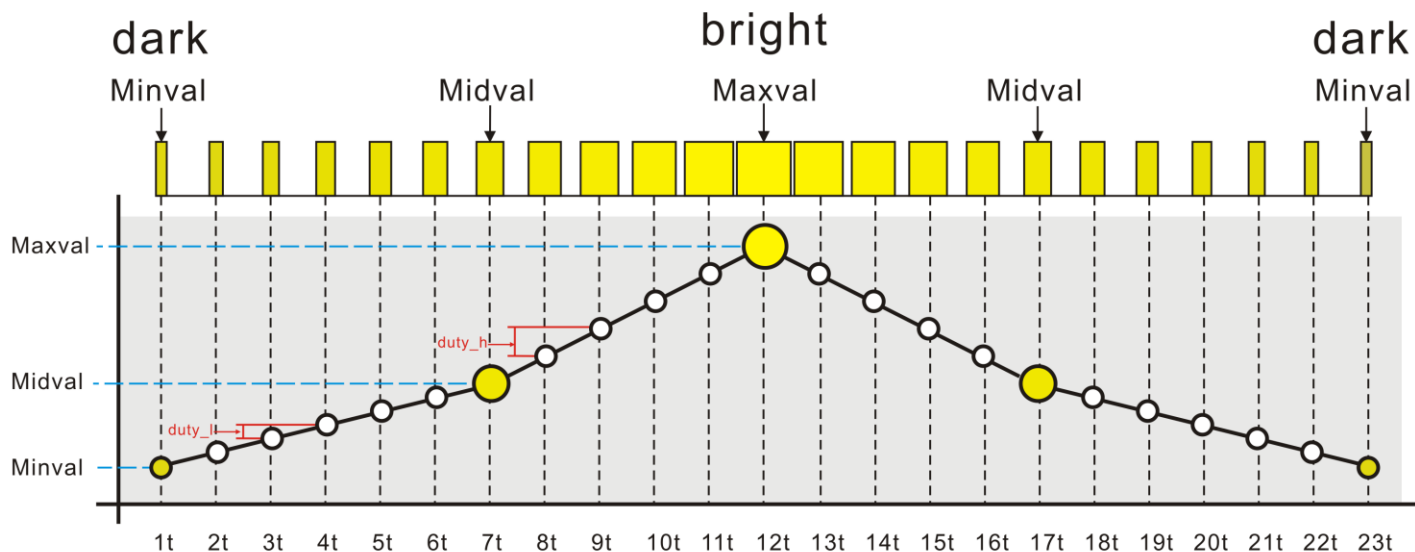

Figure 21-1 Example of Fading LED

21.2 MODULE OPERATION

MAXVAL:

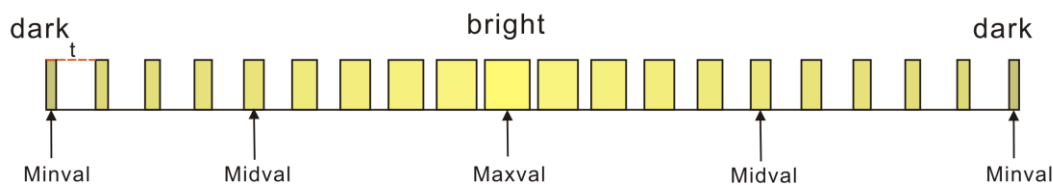

Fig1. Maxval=8'hF0

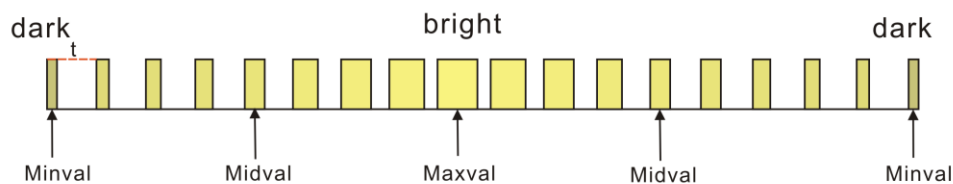

Fig2. Maxval=8'hC0

MIDVAL:

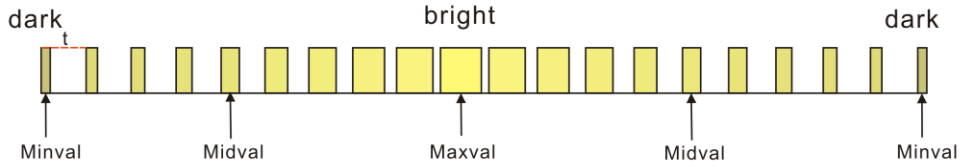

Fig1. Midval=8'h3F

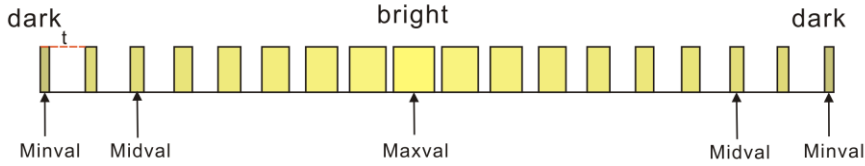

Fig2. Midval=8'h1F

MINVAL:

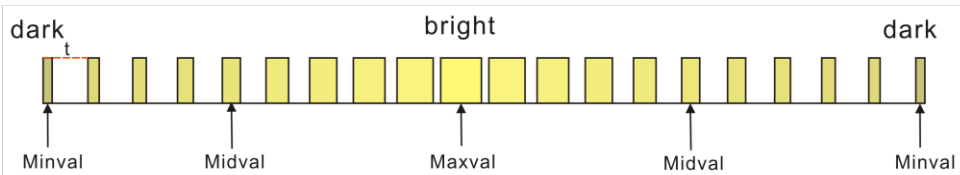

Fig1. Minval=8'h01

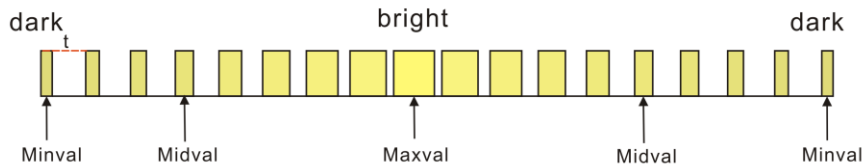

Fig2. Minval=8'h0F

DUTY HIGH, DUTY LOW:

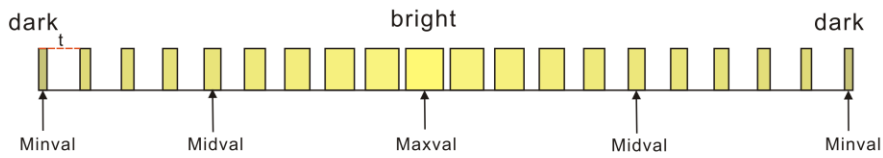

Fig1. Duty_h=2, Duty_l=1

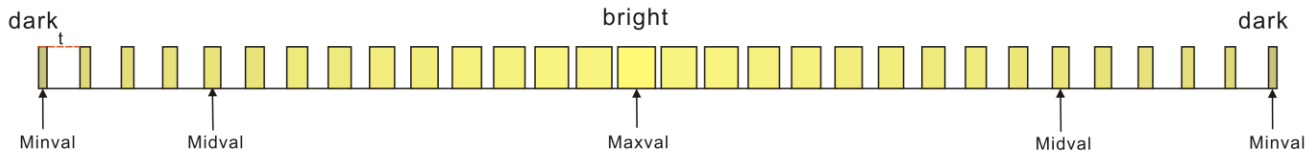

Fig2. Duty_h=1, Duty_l=1

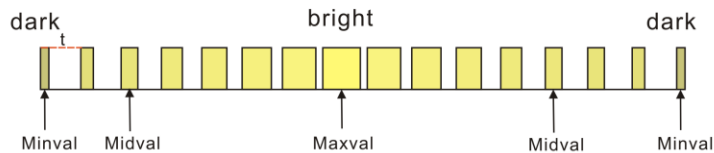

Fig3. Duty_h=2, Duty_l=2

PRGVAL: (Repeat Duty cycle value)

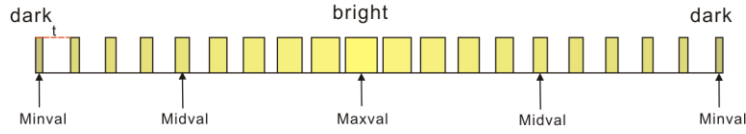

Fig1. Prgval=0

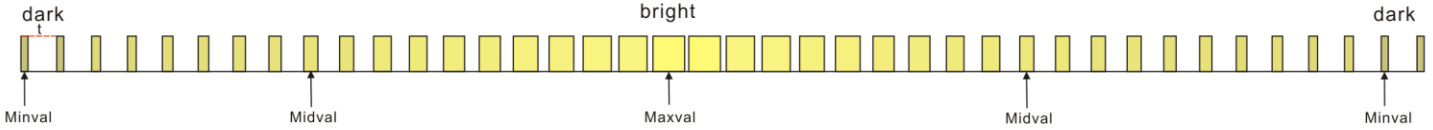

Fig2. Prgval=1

21.3 EXAMPLE ILLUSTRATION

The fading led supports three display mode, solid led, blink led, and fading led. Take pled as an example, solid led is configured through control registers logical device 15 CR[E0], CR[E5], CR[E8], shows in table 3.1, blink led is configured through control registers logical device 15 CR[E0], CR[E5], CR[E8], shows in table 3.2, fading led is configured through control registers logical device 15 CR[E0]~CR[E8] shows in table 3.3.

Table 21-1 Solid led configure mode

Logical Device 15	
Register location	Value
CR E0	8'h7F
CR E5	8'h02
CR E8	8'h10

Table 21-2 Blink led configure mode

Logical Device 15	
Register location	Value
CR E0	8'h7F
CR E5	8'h00
CR E8	8'h02

Table 21-3 Fading led configure mode

Logical Device 15	
Register location	Value
CR E0	8'hFF
CR E1	8'h7F
CR E2	8'h01
CR E3	8'h11

Logical Device 15	
Register location	Value
CR E4	8'h11
CR E5	8'h23
CR E6	8'h00
CR E7	8'h00
CR E8	8'h10

22. PORT80 TO UART

The NCT6102D / NCT6106D provides UART interface to transfer PORT80 information to other peripheral devices. Default baud rate is 115200Hz for universal UART protocol and it could be change by LD14 CRE2 and LD14 CRE3. When BIOS program PORT80 LED, in proportion to UART baud rate, it changes very frequently. Thus, some information might be lose. But we make sure the last one would be send.

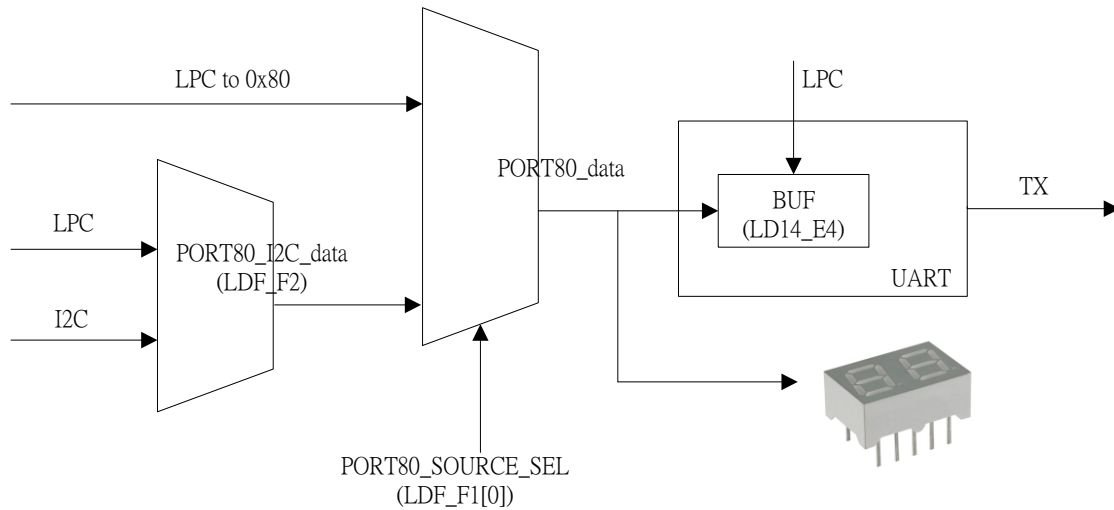

Figure 22-1 PORT80 to UART Block Diagram

After enter OS, we support other root to control PORT80 LED by write LDF CRF2 and LDF CRF1 to change other path. The UART could be control by other root, too. It is set by LD14 CRE4.

23. CONFIGURATION REGISTER

23.1 Chip (Global) Control Register

CR 02h. Software Reset Register

Location: Address 02h

Attribute: Write Only

Power Well: VCC

Reset by: LRESET#

Default :

Size: 8 bits

BIT	READ / WRITE	DESCRIPTION
7-1	Reserved.	
0	Write "1" Only	Software RESET.

CR 07h. Logical Device Selection

Location: Address 07h

Attribute: Read/Write

Power Well: VCC

Reset by: LRESET#

Default : 00h

Size: 8 bits

BIT	READ / WRITE	DESCRIPTION
7-0	R / W	Logical Device Number.

CR 10h. Device IRQ TYPE Selection

Location: Address 10h

Attribute: Read/Write

Power Well: VCC

Reset by: LRESET#

Default : FFh

Size: 8 bits

BIT	READ / WRITE	DESCRIPTION
7	R / W	FDC IRQ TYPE SELECT (note1.) 0: Edge. 1: Level.
6	R / W	PRT IRQ TYPE SELECT (note1.) 0: Edge. 1: Level.
5	R / W	UARTA IRQ TYPE SELECT (note1.) 0: Edge. 1: Level.

BIT	READ / WRITE	DESCRIPTION
4	R / W	UARTB IRQ TYPE SELECT (note1.) 0: Edge. 1: Level.
3	R / W	KBC IRQ TYPE SELECT (note1.) 0: Edge. 1: Level.
2	R / W	MOUSE IRQ TYPE SELECT (note1.) 0: Edge. 1: Level.
1	R / W	CIR IRQ TYPE SELECT (note1.) 0: Edge. 1: Level.
0	R / W	CIRWAKUP IRQ TYPE SELECT (note1.) 0: Edge. 1: Level.

Note1: Before accessing CR10, CR11, CR13 and CR14, CR26 [Bit4] must be set to logic 1.

CR 11h. Device IRQ TYPE Selection

Location: Address 11h

Attribute: Read/Write

Power Well: VCC

Reset by: LRESET#

Default : FFh

Size: 8 bits

BIT	READ / WRITE	DESCRIPTION
7	R / W	HM IRQ TYPE SELECT (note1.) 0: Edge. 1: Level.
6	R / W	WDTO IRQ TYPE SELECT (note1.) 0: Edge. 1: Level.
5	R / W	UARTC IRQ TYPE SELECT (note1.) 0: Edge. 1: Level.
4	R / W	UARTD IRQ TYPE SELECT (note1.) 0: Edge. 1: Level.
3	R / W	UARTE IRQ TYPE SELECT (note1.) 0: Edge. 1: Level.



BIT	READ / WRITE	DESCRIPTION
2	R / W	UARTF IRQ TYPE SELECT (note1.) 0: Edge. 1: Level.
1	R / W	SMI IRQ TYPE SELECT (note1.) 0: Edge. 1: Level.
0	Reserved.	

Note1: Before accessing CR10, CR11, CR13 and CR14, CR26 [Bit4] must be set to logic 1.

CR 13h. Device IRQ Polarity Selection

Location: Address 13h

Attribute: Read/Write

Power Well: VCC

Reset by: LRESET#

Default : 00h

Size: 8 bits

BIT	READ / WRITE	DESCRIPTION
7-0	R / W	IRQ Channel<15:8> Polarity (note1.) 0: High. 1: Low.

Note1: Before accessing CR10, CR11, CR13 and CR14, CR26 [Bit4] must be set to logic 1.

CR 14h. Device IRQ Polarity Selection

Location: Address 14h

Attribute: Read/Write

Power Well: VCC

Reset by: LRESET#

Default : 00h

Size: 8 bits

BIT	READ / WRITE	DESCRIPTION
7-0	R / W	IRQ Channel<7:0> Polarity (note1.) 0: High. 1: Low.

Note1: Before accessing CR10, CR11, CR13 and CR14, CR26 [Bit4] must be set to logic 1.

CR 1Ah. Multi Function Selection

Location: Address 1Ah

Attribute: Read/Write

Power Well: VSB

Reset by: RSMRST#

Default : CCh

Size: 8 bits

BIT	READ / WRITE	DESCRIPTION			
7	R / W	Pin15 function selection			
		CR24 [Bit7]	CR1A [Bit7]	Pin15	
		0	0	IRRX	
		0	1	CIRRX	
		1	x	WP#	
6	R / W	Pin16 function selection			
		CR24 [Bit7]	CR1A [Bit6]	Pin16	
		0	0	IRTX	
		0	1	CIRTX	
		1	x	RDATA#	
5-4	R / W	Pin31 function selection			
		GPIO_PORT80_SEL	CR1A [Bit5-4]	CR24 [Bit7]	Pin31
		1	xx	x	LED_A
		0	00	x	PLED
		0	01	x	SLCT
		0	1x	0	DRVDE0
		Pin32 function selection			
		GPIO_PORT80_SEL	CR1A [Bit5-4]	CR24 [Bit7]	Pin32
		1	xx	x	LED_B
		0	00	x	GP30
		0	01	x	PE
		0	1x	0	INDEX#
		Pin33 function selection			
		GPIO_PORT80_SEL	CR1A [Bit5-4]	CR24 [Bit7]	Pin33
		1	xx	x	LED_C
		0	00	x	GP31
0	01	x	BUSY		
0	1x	0	MOA#		

BIT	READ / WRITE	DESCRIPTION			
5-4	R / W	Pin34 function selection			
		GPIO_PORT80_SEL	CR1A [Bit5-4]	CR24 [Bit7]	Pin34
		1	xx	x	LED_D
		0	00	x	GP32
		0	01	x	ACK#
		0	1x	0	DSA#
		Pin35 function selection			
		GPIO_PORT80_SEL	CR1A [Bit5-4]	CR24 [Bit7]	Pin35
		1	xx	x	LED_E
		0	00	x	GP33
		0	01	x	PD7
		0	1x	0	DIR#
		Pin36 function selection			
		GPIO_PORT80_SEL	CR1A [Bit5-4]	CR24 [Bit7]	Pin36
		1	xx	x	LED_F
		0	00	x	GP34
		0	01	x	PD6
		0	1x	0	STEP#
		Pin37 function selection			
		GPIO_PORT80_SEL	CR1A [Bit5-4]	CR24 [Bit7]	Pin37
		1	xx	x	LED_G
		0	00	x	GP35
		0	01	x	PD5
		0	1x	0	WD#
		Pin38 function selection			
		GPIO_PORT80_SEL	CR1A [Bit5-4]	CR24 [Bit7]	Pin38
		1	xx	x	DGH#
		0	00	x	GP36
0	01	x	PD4		
0	1x	0	WE#		
Pin39 function selection					
GPIO_PORT80_SEL	CR1A [Bit5-4]	CR24 [Bit7]	Pin39		
1	xx	x	DGL#		
0	00	x	GP37		
0	01	x	PD3		
0	1x	0	TRAK0#		

BIT	READ / WRITE	DESCRIPTION			
5-4	R / W	Pin40 function selection			
		GPIO_PORT80_SEL	CR1A [Bit5-4]	CR24 [Bit7]	Pin40
		1	xx	x	GP40
		0	00	x	GP40
		0	01	x	PD2
		0	1x	0	WP#
		Pin41 function selection			
		GPIO_PORT80_SEL	CR1A [Bit5-4]	CR24 [Bit7]	Pin41
		1	xx	x	GP41
		0	00	x	GP41
		0	01	x	PD1
		0	1x	0	RDATA#
		Pin42 function selection			
		GPIO_PORT80_SEL	CR1A [Bit5-4]	CR24 [Bit7]	Pin42
		1	xx	x	GP42
		0	00	x	GP42
		0	01	x	PD0
		0	1x	0	HEAD#
		Pin43 function selection			
		GPIO_PORT80_SEL	CR1A [Bit5-4]	CR24 [Bit7]	Pin43
		1	xx	x	GP43
		0	00	x	GP43
		0	01	x	SLIN#
		0	1x	0	DSKCHG#
		Pin44 function selection			
		GPIO_PORT80_SEL	CR1A [Bit5-4]		Pin44
		1	xx		GP44
		0	00		GP44
0	01		INIT#		
0	1x		GP44		
Pin45 function selection					
GPIO_PORT80_SEL	CR1A [Bit5-4]		Pin45		
1	xx		GP45		
0	00		GP45		
0	01		ERR#		
0	1x		GP45		

BIT	READ / WRITE	DESCRIPTION		
5-4	R / W	Pin46 function selection		
		GPIO_PORT80_SEL	CR1A [Bit5-4]	Pin46
		1	xx	GP46
		0	00	GP46
		0	01	AFD#
		0	1x	GP46
		Pin47 function selection		
		GPIO_PORT80_SEL	CR1A [Bit5-4]	Pin47
		1	xx	GP47
		0	00	GP47
0	01	STB#		
0	1x	GP47		
3	R / W	Pin62 function selection		
		CR1A [Bit3]	Pin62	
		0	GP50	
		1	KCLK	
		Pin63 function selection		
		CR1A [Bit3]	Pin63	
0	GP51			
1	KDAT			
2	R / W	Pin65 function selection		
		CR1A [Bit2]	Pin65	
		0	GP52	
		1	MCLK	
		Pin66 function selection		
		CR1A [Bit2]	Pin66	
0	GP53			
1	MDAT			
1	R / W	Pin67 function selection		
		CR1A [Bit1]	Pin67	
		0	PSOUT#	
1	GP54			
0	R / W	Pin68 function selection		
		CR1A [Bit0]	Pin68	
		0	PSIN#	
1	GP55			

**CR 1Bh. Multi Function Selection**

Location: Address 1Bh

Attribute: Read/Write

Power Well: VSB

Reset by: RSMRST#

Default : 03h

Size: 8 bits

BIT	READ / WRITE	DESCRIPTION		
7	R / W	Pin70 function selection		
		CR1B [Bit7]	Pin70	
		0	SLP_S5#	
		1	GP56	
6	R / W	Pin71 function selection		
		CR1B [Bit6]	Pin71	
		0	PWROK	
		1	GP57	
5	R / W	Pin72 function selection		
		CR1B [Bit5]	Pin72	
		0	PSON#	
		1	GP60	
4	R / W	Pin73 function selection		
		CR1B [Bit4]	Pin73	
		0	SLP_S3#	
		1	GP61	
3	R / W	Pin75 function selection		
		CR1B [Bit3]	Pin75	
		0	RSMRST#	
		1	GP62	
2	R / W	Pin87 function selection		
		CR27 [Bit3]	CR1B [Bit2]	Pin87
		0	0	GP71
		0	1	TSIC
		1	x	CIRRXWB
		Pin88 function selection		
		CR1B [Bit2]	Pin88	
		0	PECI	
		1	TSID	



BIT	READ / WRITE	DESCRIPTION	
1-0	R / W	Pin94 function selection	
		CR1B [Bit1-0]	Pin94
		1x	SDA
		00	GP63
		01	MSDA
		Pin96 function selection	
		CR1B [Bit1-0]	Pin96
		1x	SCL
00	GP64		
01	MSCL		

CR 1Ch. Multi Function Selection

Location: Address 1Ch

Attribute: Read/Write

Power Well: VSB

Reset by: RSMRST#

Default : 10h

Size: 8 bits

BIT	READ / WRITE	DESCRIPTION		
7	R / W	Pin95 function selection		
		CR1C [Bit7]	Pin95	
		0	OVT#	
		1	SMI#	
6	R / W	Pin106 function selection		
		CR1C [Bit6]	Pin106	
		0	SUSLED	
		1	GP65	
5	R / W	Pin107 function selection		
		CR1C [Bit5]	Pin107	
		0	KEYLOCK#	
		1	GP66	
4	R / W	Pin108 function selection		
		CR27 [Bit2]	CR1C [Bit4]	Pin108
		0	0	14.7456MHZ_CLKIN
		0	1	GP67
		1	x	ATXPGD



BIT	READ / WRITE	DESCRIPTION		
3	R / W	Pin109-116 function selection		
		SOUTC_P80_SEL	CR1C [Bit3]	Pin109-116
		1	x	GP0x, SOUTC_P80
		0	0	GP0x
2	R / W	Pin117-124 function selection		
		CR1C [Bit2]	Pin117-124	
		0	GP1x	
1	R / W	Pin125-4 function selection		
		SOUTE_P80_SEL	CR1C [Bit1]	Pin125-4
		1	x	GP2x, SOUTE_P80
		0	0	GP2x
0	Reserved.	0	1	UARTE

CR 20h. Chip ID (High Byte)

Location: Address 20h

Attribute: Read Only

Power Well: VCC

Reset by: None

Default : 10h

Size: 8 bits

BIT	READ / WRITE	DESCRIPTION
7-0	Read Only	Chip ID number = 10h (high byte).

CR 21h. Chip ID (Low Byte)

Location: Address 21h

Attribute: Read Only

Power Well: VCC

Reset by: None

Default : 61h

Size: 8 bits

BIT	READ / WRITE	DESCRIPTION
7-0	Read Only	Chip ID number = 61h (low byte)

CR 22h. Device Power Down

Location: Address 22h

Attribute: Read/Write



Power Well: VCC
 Reset by: LRESET#
 Default : 7Fh
 Size: 8 bits

BIT	READ / WRITE	DESCRIPTION
7	R / W	DSIRLGRQ => = 0 Enable IR legacy mode for IRQ selection. Then HCR register (base address + 4) bit 3 is effective when selecting IRQ. = 1 Disable IR legacy mode for IRQ selection. Then HCR register (base address + 4) bit 3 is not effective when selecting IRQ.
6	R / W	IR Power Down. 0: Powered down. 1: Not powered down.
5	R / W	UARTB Power Down. 0: Powered down. 1: Not powered down.
4	R / W	UARTA Power Down. 0: Powered down. 1: Not powered down.
3	R / W	PRT Power Down. 0: Powered down. 1: Not powered down.
2	Reserved.	
1	R / W	IPD (Immediate Power Down). When set to 0, the whole chip is put into power-down mode immediately.
0	R / W	FDC Power Down. 0: Powered down. 1: Not powered down.

CR 24h. Multi Function Selection & Global Option

Location: Address 24h
 Attribute: Read/Write
 Power Well: VCC
 Reset by: LRESET#
 Default : 00h
 Size: 8 bits

BIT	READ / WRITE	DESCRIPTION																		
7	R / W	Pin5 function selection <table border="1"> <tr> <td>CR24 [Bit7]</td> <td>Pin5</td> </tr> <tr> <td>0</td> <td>CTSF#</td> </tr> <tr> <td>1</td> <td>DRVDEN0</td> </tr> </table> Pin6 function selection <table border="1"> <tr> <td>CR24 [Bit7]</td> <td>Pin6</td> </tr> <tr> <td>0</td> <td>AUXFANIN</td> </tr> <tr> <td>1</td> <td>INDEX#</td> </tr> </table> Pin7 function selection <table border="1"> <tr> <td>CR24 [Bit7]</td> <td>Pin7</td> </tr> <tr> <td>0</td> <td>DSRF#</td> </tr> <tr> <td>1</td> <td>MOA#</td> </tr> </table>	CR24 [Bit7]	Pin5	0	CTSF#	1	DRVDEN0	CR24 [Bit7]	Pin6	0	AUXFANIN	1	INDEX#	CR24 [Bit7]	Pin7	0	DSRF#	1	MOA#
CR24 [Bit7]	Pin5																			
0	CTSF#																			
1	DRVDEN0																			
CR24 [Bit7]	Pin6																			
0	AUXFANIN																			
1	INDEX#																			
CR24 [Bit7]	Pin7																			
0	DSRF#																			
1	MOA#																			

BIT	READ / WRITE	DESCRIPTION										
7	R / W	Pin8 function selection										
		<table border="1"> <thead> <tr> <th>CR24 [Bit7]</th> <th>Pin8</th> </tr> </thead> <tbody> <tr> <td>0</td> <td>RTSF#</td> </tr> <tr> <td>1</td> <td>DSA#</td> </tr> </tbody> </table>	CR24 [Bit7]	Pin8	0	RTSF#	1	DSA#				
		CR24 [Bit7]	Pin8									
		0	RTSF#									
		1	DSA#									
		Pin9 function selection										
		<table border="1"> <thead> <tr> <th>CR24 [Bit7]</th> <th>Pin9</th> </tr> </thead> <tbody> <tr> <td>0</td> <td>DTRF#</td> </tr> <tr> <td>1</td> <td>DIR#</td> </tr> </tbody> </table>	CR24 [Bit7]	Pin9	0	DTRF#	1	DIR#				
		CR24 [Bit7]	Pin9									
		0	DTRF#									
		1	DIR#									
		Pin10 function selection										
		<table border="1"> <thead> <tr> <th>CR24 [Bit7]</th> <th>Pin10</th> </tr> </thead> <tbody> <tr> <td>0</td> <td>SINF</td> </tr> <tr> <td>1</td> <td>STEP#</td> </tr> </tbody> </table>	CR24 [Bit7]	Pin10	0	SINF	1	STEP#				
		CR24 [Bit7]	Pin10									
		0	SINF									
		1	STEP#									
		Pin11 function selection										
		<table border="1"> <thead> <tr> <th>CR24 [Bit7]</th> <th>Pin11</th> </tr> </thead> <tbody> <tr> <td>0</td> <td>SOUTF</td> </tr> <tr> <td>1</td> <td>WD#</td> </tr> </tbody> </table>	CR24 [Bit7]	Pin11	0	SOUTF	1	WD#				
		CR24 [Bit7]	Pin11									
		0	SOUTF									
		1	WD#									
		Pin13 function selection										
		<table border="1"> <thead> <tr> <th>CR24 [Bit7]</th> <th>Pin13</th> </tr> </thead> <tbody> <tr> <td>0</td> <td>DCDF#</td> </tr> <tr> <td>1</td> <td>WE#</td> </tr> </tbody> </table>	CR24 [Bit7]	Pin13	0	DCDF#	1	WE#				
		CR24 [Bit7]	Pin13									
		0	DCDF#									
		1	WE#									
		Pin14 function selection										
		<table border="1"> <thead> <tr> <th>CR24 [Bit7]</th> <th>Pin14</th> </tr> </thead> <tbody> <tr> <td>0</td> <td>AUXFANOUT</td> </tr> <tr> <td>1</td> <td>TRAK0#</td> </tr> </tbody> </table>	CR24 [Bit7]	Pin14	0	AUXFANOUT	1	TRAK0#				
CR24 [Bit7]	Pin14											
0	AUXFANOUT											
1	TRAK0#											
Pin15 function selection												
<table border="1"> <thead> <tr> <th>CR24 [Bit7]</th> <th>CR1A [Bit7]</th> <th>Pin15</th> </tr> </thead> <tbody> <tr> <td>0</td> <td>0</td> <td>IRRX</td> </tr> <tr> <td>0</td> <td>1</td> <td>CIRRX</td> </tr> <tr> <td>1</td> <td>x</td> <td>WP#</td> </tr> </tbody> </table>	CR24 [Bit7]	CR1A [Bit7]	Pin15	0	0	IRRX	0	1	CIRRX	1	x	WP#
CR24 [Bit7]	CR1A [Bit7]	Pin15										
0	0	IRRX										
0	1	CIRRX										
1	x	WP#										

BIT	READ / WRITE	DESCRIPTION												
7	R / W	Pin16 function selection												
		<table border="1"> <thead> <tr> <th>CR24 [Bit7]</th> <th>CR1A [Bit6]</th> <th>Pin16</th> </tr> </thead> <tbody> <tr> <td>0</td> <td>0</td> <td>IRTX</td> </tr> <tr> <td>0</td> <td>1</td> <td>CIRTX</td> </tr> <tr> <td>1</td> <td>x</td> <td>RDATA#</td> </tr> </tbody> </table>	CR24 [Bit7]	CR1A [Bit6]	Pin16	0	0	IRTX	0	1	CIRTX	1	x	RDATA#
		CR24 [Bit7]	CR1A [Bit6]	Pin16										
		0	0	IRTX										
		0	1	CIRTX										
		1	x	RDATA#										
		Pin17 function selection												
		<table border="1"> <thead> <tr> <th>CR24 [Bit7]</th> <th>Pin17</th> </tr> </thead> <tbody> <tr> <td>0</td> <td>RIF#</td> </tr> <tr> <td>1</td> <td>HEAD#</td> </tr> </tbody> </table>	CR24 [Bit7]	Pin17	0	RIF#	1	HEAD#						
		CR24 [Bit7]	Pin17											
		0	RIF#											
		1	HEAD#											
		Pin18 function selection												
<table border="1"> <thead> <tr> <th>CR24 [Bit7]</th> <th>Pin18</th> </tr> </thead> <tbody> <tr> <td>0</td> <td>BEEP</td> </tr> <tr> <td>1</td> <td>DSKCHG#</td> </tr> </tbody> </table>	CR24 [Bit7]	Pin18	0	BEEP	1	DSKCHG#								
CR24 [Bit7]	Pin18													
0	BEEP													
1	DSKCHG#													
Pin31-43 function selection See CR 1Ah.														
6	R / W	Select output type of SYSFANOUT =0 SYSFANOUT is Open-drain. (Default) =1 SYSFANOUT is Push-pull.												
5	R / W	Select output type of CPUFANOUT =0 CPUFANOUT is Open-drain. (Default) =1 CPUFANOUT is Push-pull.												
4	R / W	Select output type of AUXFANOUT =1 AUXFANOUT is Open-drain. =0 AUXFANOUT is Push-pull. (Default)												
3	R / W	Pin14 AUXFANOUT Function Output Enable =0 Disable =1 Enable												
2	R / W	Pin16 CIRTX Function Output Enable =0 Disable =1 Enable												
1	R / W	Pin18 BEEP Function Output Enable =0 Disable =1 Enable												
0	R / W	PNPCVS => = 0 The compatible PNP address-select registers have default values. = 1 The compatible PNP address-select registers have no default values.												

CR 25h. Interface Tri-state Enable

Location: Address 25h



Attribute: Read/Write

Power Well: VCC

Reset by: LRESET#

Default : 00h

Size: 8 bits

BIT	READ / WRITE	DESCRIPTION
7	R / W	UARTFTRI
6	R / W	UARTETRI
5	R / W	UARTDTRI
4	R / W	UARTCTRI
3	R / W	UARTBTTRI
2	R / W	UARTATRI
1	R / W	PRTRTRI
0	R / W	FDCTRI.

CR 26h. Global Option s: value by strapping

Location: Address 26h

Attribute: Read/Write

Power Well: VCC

Reset by: LRESET#

Default : 0s000000b

Size: 8 bits

BIT	READ / WRITE	DESCRIPTION
7	Reserved.	
6	R / W	HEFRAS => = 0 Write 87h to location 2E twice. = 1 Write 87h to location 4E twice. The corresponding power-on strapping pin is RTSA# (Pin51).
5	R / W	LOCKREG => = 0 Enable R/W configuration registers. = 1 Disable R/W configuration registers.
4	Reserved.	
3	R / W	DSFDLGRQ => = 0 Enable FDC legacy mode for IRQ and DRQ selection. Then DO register (base address + 2) bit 3 is effective when selecting IRQ. = 1 Disable FDC legacy mode for IRQ and DRQ selection. Then DO register (base address + 2) bit 3 is not effective when selecting IRQ.
2	R / W	DSPRLGRQ => = 0 Enable PRT legacy mode for IRQ and DRQ selection. Then DCR register (base address + 2) bit 4 is effective when selecting IRQ. = 1 Disable PRT legacy mode for IRQ and DRQ selection. Then DCR register (base address + 2) bit 4 is not effective when selecting IRQ.



BIT	READ / WRITE	DESCRIPTION
1	R / W	DSUALGRQ => = 0 Enable UART A legacy mode for IRQ selection. Then HCR register (base address + 4) bit 3 is effective when selecting IRQ. = 1 Disable UART A legacy mode for IRQ selection. Then HCR register (base address + 4) bit 3 is not effective when selecting IRQ.
0	R / W	DSUBLGRQ => = 0 Enable UART B legacy mode for IRQ selection. Then HCR register (base address + 4) bit 3 is effective when selecting IRQ. = 1 Disable URAT B legacy mode for IRQ selection. Then HCR register (base address + 4) bit 3 is not effective when selecting IRQ.

CR 27h. Global Option

Location: Address 27h

Attribute: Read/Write

Power Well: VSB

Reset by: RSMRST#

Default : 00h

Size: 8 bits

BIT	READ / WRITE	DESCRIPTION												
7-4	Reserved.													
3	R / W	Pin87 function selection												
		<table border="1"> <thead> <tr> <th>CR27 [Bit3]</th> <th>CR1B [Bit2]</th> <th>Pin87</th> </tr> </thead> <tbody> <tr> <td>0</td> <td>0</td> <td>GP71</td> </tr> <tr> <td>0</td> <td>1</td> <td>TSIC</td> </tr> <tr> <td>1</td> <td>x</td> <td>CIRRXWB</td> </tr> </tbody> </table>	CR27 [Bit3]	CR1B [Bit2]	Pin87	0	0	GP71	0	1	TSIC	1	x	CIRRXWB
		CR27 [Bit3]	CR1B [Bit2]	Pin87										
		0	0	GP71										
0	1	TSIC												
1	x	CIRRXWB												
2	R / W	Pin108 function selection												
		<table border="1"> <thead> <tr> <th>CR27 [Bit2]</th> <th>CR1C [Bit4]</th> <th>Pin108</th> </tr> </thead> <tbody> <tr> <td>0</td> <td>0</td> <td>14.7456MHZ_CLKIN</td> </tr> <tr> <td>0</td> <td>1</td> <td>GP67</td> </tr> <tr> <td>1</td> <td>x</td> <td>ATXPGD</td> </tr> </tbody> </table>	CR27 [Bit2]	CR1C [Bit4]	Pin108	0	0	14.7456MHZ_CLKIN	0	1	GP67	1	x	ATXPGD
		CR27 [Bit2]	CR1C [Bit4]	Pin108										
0	0	14.7456MHZ_CLKIN												
0	1	GP67												
1	x	ATXPGD												
1	R / W	Pin16 IRTX Function Output Enable =0 Disable =1 Enable												
0	R / W	Pin31 PLED Function Output Enable =0 Disable =1 Enable												

CR 28h. Global Option

Location: Address 28h

Attribute: Read/Write

Power Well: VCC



Reset by: LRESET#

Default : 00h

Size: 8 bits

BIT	READ / WRITE	DESCRIPTION
7-6	Reserved.	
5-4	R / W	0 0: LPC or I2C to 80PORT switch 0 1: CPU temperature to 80PORT switch 1 0: SYS temperature to 80PORT switch 1 1: AUX temperature to 80PORT switch
3	Reserved.	
2-0	R / W	PRTMODS2 ~ 0 => Bits 2 1 0 = 0 x x Parallel Port Mode. = 1 x x Reserved.

CR 29h. Global Option

Location: Address 29h

Attribute: Read/Write

Power Well: VCC

Reset by: LRESET#

Default : F0h

Size: 8 bits

BIT	READ / WRITE	DESCRIPTION
7	R / W	UARTF Power Down. 0: Powered down. 1: Not powered down.
6	R / W	UARTE Power Down. 0: Powered down. 1: Not powered down.
5	R / W	UARTD Power Down. 0: Powered down. 1: Not powered down.
4	R / W	UARTC Power Down. 0: Powered down. 1: Not powered down.
3	R / W	DSUFLGRQ => = 0 Enable UART F legacy mode for IRQ selection. Then HCR register (base address + 4) bit 3 is effective when selecting IRQ. = 1 Disable UART F legacy mode for IRQ selection. Then HCR register (base address + 4) bit 3 is not effective when selecting IRQ.
2	R / W	DSUELGRQ => = 0 Enable UART E legacy mode for IRQ selection. Then HCR register (base address + 4) bit 3 is effective when selecting IRQ. = 1 Disable UART E legacy mode for IRQ selection. Then HCR register (base address + 4) bit 3 is not effective when selecting IRQ.
1	R / W	DSUDLGRQ => = 0 Enable UART D legacy mode for IRQ selection. Then HCR register (base address + 4) bit 3 is effective when selecting IRQ. = 1 Disable UART D legacy mode for IRQ selection. Then HCR register (base address + 4) bit 3 is not effective when selecting IRQ.



BIT	READ / WRITE	DESCRIPTION
0	R / W	DSUCLGRQ => = 0 Enable UART C legacy mode for IRQ selection. Then HCR register (base address + 4) bit 3 is effective when selecting IRQ. = 1 Disable UART C legacy mode for IRQ selection. Then HCR register (base address + 4) bit 3 is not effective when selecting IRQ.

CR 2Ah. Global Option

Location: Address 2Ah

Attribute: Read/Write

Power Well: VSB

Reset by: RSMRST#

Default : 00h

Size: 8 bits

BIT	READ / WRITE	DESCRIPTION
7-3	Reserved.	
2	R/W	OVT# Power Down Selection =0 Disable =1 Enable
1-0	Reserved.	

CR 2Fh. Strapping Function Result

Location: Address 2Fh

Attribute: Read/Write

Power Well: VSB

Reset by: PWROK#, RSMRST# (Bit2)

Default : by 000s_ssss

Size: 8 bits

BIT	READ / WRITE	DESCRIPTION
7-5	Reserved.	
4	R / W	SOUTE_P80_SEL Strapping result reading, it can output the port80 data to UARTE interface.
3	R / W	SOUTC_P80_SEL Strapping result reading, it can output the port80 data to UARTE interface.
2	R / W	COMB_DSW_SEL Strapping result reading, it can switch UARTB pad-mux to DSW function.
1	R / W	GPIO_PORT80_SEL Strapping result reading
0	R / W	24M_48M_SEL Strapping result reading

Note . All Strapping results can be programming by LPC Interface. There are three conditions below:

- 3) VSB Strapping result can be programming by LPC, and reset by RSMRST#
- 4) VCC Strapping result can be programming by LPC, and reset by PWROK
- 5) LRESET Strapping (2E_4E_SEL) : No change



23.2 Logical Device 0 (FDC)

CR 30h.

Location: Address 30h

Attribute: Read/Write

Power Well: VCC

Reset by: LRESET#

Default : 01h

Size: 8 bits

BIT	READ / WRITE	DESCRIPTION
7-1	Reserved.	
0	R / W	0: The FDC device is inactive. 1: The FDC device is active.

CR 60h, 61h.

Location: Address 60h, 61h

Attribute: Read/Write

Power Well: VCC

Reset by: LRESET#

Default : 03h, F0h

Size: 16 bits

BIT	READ / WRITE	DESCRIPTION
7~0	R / W	These two registers select FDC I/O base address <100h: FF8h> on 8 bytes boundary.

CR 70h.

Location: Address 70h

Attribute: Read/Write

Power Well: VCC

Reset by: LRESET#

Default : 06h

Size: 8 bits

BIT	READ / WRITE	DESCRIPTION
7-4	Reserved.	
3-0	R / W	These bits select IRQ resource for FDC.

CR 74h.

Location: Address 74h

Attribute: Read/Write

Power Well: VCC

Reset by: LRESET#

Default : 02h

Size: 8 bits



BIT	READ / WRITE	DESCRIPTION
7-3	Reserved.	
2-0	R / W	These bits select DRQ resource for FDC. 000: DMA0. 001: DMA1. 010: DMA2. 011: DMA3. 1xx: No DMA active.

CR F0h.

Location: Address F0h

Attribute: Read/Write

Power Well: VCC

Reset by: LRESET#

Default : 0Eh

Size: 8 bits

BIT	READ / WRITE	DESCRIPTION
7	Reserved.	
6	R / W	This bit determines the polarity of all FDD interface signals. 0: FDD interface signals are active low. 1: FDD interface signals are active high.
5	R / W	When this bit is logic 0, indicates a second drive is installed and is reflected in status register A. (PS2 mode only)
4	R / W	Swap Drive 0, 1 Mode => 0: No Swap. 1: Drive and Motor select 0 and 1 are swapped.
3-2	R / W	Interface Mode. 00: Model 30. 01: PS/2. 10: Reserved. 11: AT Mode
1	R / W	FDC DMA Mode. 0 : Burst Mode is enabled 1 : Non-Burst Mode.
0	R / W	Floppy Mode. 0 : Normal Floppy Mode. 1: Enhanced 3-mode FDD.

CR F1h.

Location: Address F1h

Attribute: Read/Write

Power Well: VCC

Reset by: LRESET#

Default : 00h

Size: 8 bits

BIT	READ / WRITE	DESCRIPTION
7-6	R / W	Boot Floppy. 00: FDD A. 01: Reserved. 10: Reserved. 11: Reserved.
5-4	R / W	Media ID1, Media ID0. These bits will be reflected on FDC's Tape Drive Register bit 7, 6.

**CR F5h.**

Location: Address F5h

Attribute: Read/Write

Power Well: VCC

Reset by: LRESET#

Default : 00h

Size: 8 bits

BIT	READ / WRITE	DESCRIPTION
7-0	R / W	Same as FDD0 of CR F5h.

TABLE A

DRIVE RATE TABLE SELECT		DATA RATE		SELECTED DATA RATE		SELDEN
DRTS1	DRTS0	DRATE1	DRATE0	MFM	FM	
0	0	1	1	1Meg	---	1
		0	0	500K	250K	1
		0	1	300K	150K	0
		1	0	250K	125K	0
0	1	1	1	1Meg	---	1
		0	0	500K	250K	1
		0	1	500K	250K	0
		1	0	250K	125K	0
1	0	1	1	1Meg	---	1
		0	0	500K	250K	1
		0	1	2Meg	---	0
		1	0	250K	125K	0

TABLE B

DTYPE0	DTYPE1	DRV DEN0 (pin 5)	DRIVE TYPE
0	0	SEL DEN	4/2/1 MB 3.5" 2/1 MB 5.25" 2/1.6/1 MB 3.5" (3-MODE)
0	1	DRATE1	
1	0	SEL DEN	
1	1	DRATE0	



23.3 Logical Device 1 (PRT)

CR 30h.

Location: Address 30h

Attribute: Read/Write

Power Well: VCC

Reset by: LRESET#

Default : 01h

Size: 8 bits

BIT	READ / WRITE	DESCRIPTION
7-1	Reserved.	
0	R / W	0: The logical device is inactive. 1: The logical device is active.

CR 60h, 61h.

Location: Address 60h, 61h

Attribute: Read/Write

Power Well: VCC

Reset by: LRESET#

Default : 03h, 78h

Size: 16 bits

BIT	READ / WRITE	DESCRIPTION
7-0	R / W	These two registers select PRT I/O base address. <100h: FFCh> on 4 bytes boundary (EPP not supported) or <100h: FF8h> on 8 bytes boundary (all modes supported, EPP is only available when the base address is on 8 byte boundary).

CR 70h.

Location: Address 70h

Attribute: Read/Write

Power Well: VCC

Reset by: LRESET#

Default : 07h

Size: 8 bits

BIT	READ / WRITE	DESCRIPTION
7-4	Reserved.	
3-0	R / W	These bits select IRQ resource for PRT.

CR 74h.

Location: Address 74h

Attribute: Read/Write

Power Well: VCC

Reset by: LRESET#

Default : 04h

Size: 8 bits



BIT	READ / WRITE	DESCRIPTION
7-3	Reserved.	
2-0	R / W	These bits select DRQ resource for PRT. 000: DMA0. 001: DMA1. 010: DMA2. 011: DMA3. 1xx: No DMA active.

CR F0h.

Location: Address F0h

Attribute: Read/Write

Power Well: VCC

Reset by: LRESET#

Default : 3Fh

Size: 8 bits

BIT	READ / WRITE	DESCRIPTION
7	Reserved.	
6-3	R / W	ECP FIFO Threshold.
2-0	R / W	Parallel Port Mode selection (CR28 bit2 PRTMODS2 = 0). Bits 2 1 0 0 0 0: Standard and Bi-direction (SPP) mode. 0 0 1: EPP – 1.9 and SPP mode. 0 1 0: ECP mode. 0 1 1: ECP and EPP – 1.9 mode. 1 0 0: Printer Mode. 1 0 1: EPP – 1.7 and SPP mode. 1 1 0: Reserved. 1 1 1: ECP and EPP – 1.7 mode.



23.4 Logical Device 2 (UARTA)

CR 30h.

Location: Address 30h

Attribute: Read/Write

Power Well: VCC

Reset by: LRESET#

Default : 01h

Size: 8 bits

BIT	READ / WRITE	DESCRIPTION
7-1	Reserved.	
0	R / W	0: The logical device is inactive. 1: The logical device is active.

CR 60h, 61h.

Location: Address 60h, 61h

Attribute: Read/Write

Power Well: VCC

Reset by: LRESET#

Default : 03h, F8h

Size: 16 bits

BIT	READ / WRITE	DESCRIPTION
7-0	R / W	These two registers select Serial Port 1 I/O base address <100h: FF8h> on 8 bytes boundary.

CR 70h.

Location: Address 70h

Attribute: Read/Write

Power Well: VCC

Reset by: LRESET#

Default : 04h

Size: 8 bits

BIT	READ / WRITE	DESCRIPTION
7-4	Reserved.	
3-0	R / W	These bits select IRQ resource for Serial Port 1.

CR F0h.

Location: Address F0h

Attribute: Read/Write

Power Well: VCC

Reset by: LRESET#

Default : 00h

Size: 8 bits



BIT	READ / WRITE	DESCRIPTION
7	R / W	0: Delay RXCLK for 5 ns for LG issue. 1: No delay of 5 ns for RXCLK.
6	R / W	0: IRQ is the level mode. 1: IRQ is the pulse mode for IRQ sharing function.
5	R / W	0: Using the original RX FIFO Error Indication signal (USR bit 7). 1: Using new RX FIFO Error Indication signal to solve some issues.
4-2	Reserved.	
1-0	R / W	Bits 1 0 0 0: UART A clock source is 1.8462 MHz (24 MHz / 13). 0 1: UART A clock source is 2 MHz (24 MHz / 12). 1 0: UART A clock source is 24 MHz (24 MHz / 1). 1 1: UART A clock source is 14.769 MHz (24 MHz / 1.625).

CR F2h. UARТА 9bit-mode Config Register

Location: Address F2h

Attribute: Read/Write

Power Well: VCC

Reset by: LRESET#

Default : 00h

Size: 8 bits

BIT	READ / WRITE	DESCRIPTION
7	R / W	En_auto_RX_ctrl 0: 9bitmode RX block function will pass all data or address byte and not compare any address byte. 1: 9bitmode RX block function could only receive address byte and compare the address bytes. (The address matched or not will issue IRQ. Refer to CRF6 description)
6	R / W	En_auto_only_addr_comp 0: When setting en_auto_RX_ctrl =1'b1, 9bitmode RX block function will compare the address byte and update the RX_ctrl Bit automatically. 1: When setting en_auto_RX_ctrl =1'b1, 9bitmode RX block function will only compare the address byte. But the RX_ctrl Bit will not be updated automatically by 9bitmode RX block function.
5	R / W	RST_low_time_sel 0: TX block will keep 1 bit time before inverting the driving signal. 1: TX block will keep 2 bit time before inverting the driving signal.
4	R / W	RS485_RTS_inv_sel 0: Automatic drive RTS# low when receiving data. Automatic drive RTS# high when transmitting data. 1: Automatic drive RTS# high when receiving data. Automatic drive RTS# low when transmitting data.



BIT	READ / WRITE	DESCRIPTION
3	R / W	En_auto_TX_ctrl 0: En_address_byte bit will not be automatic updated to "logic 0" by hardware after TX block sent address byte. 1: En_address_byte bit will be automatic updated to "logic 0" by hardware after TX block sent address byte.
2	R / W	En_auto_RX_ctrl 0: the address byte will be ingored by the receiver. 1: the address byte will be received into RX FIFO by the receiver.
1	R / W	En_RS485_RTS 0: RS232 driver 1: RS485 driver The 9bitmode TX block function will drive RTS_L to high when transmit data automatically
0	R / W	En_9bit_mode 0: normal UART function. 1: enable 9-bit mode function. (9bit-TX block use parity bit as address/Data bit when setting En_9bit_mode = 1'b1.)

CR F3h. UARTA 9bit-mode Slave Address Register

Location: Address F3h

Attribute: Read/Write

Power Well: VCC

Reset by: LRESET#

Default : 00h

Size: 8 bits

BIT	READ / WRITE	DESCRIPTION
7-0	R / W	Slave address

CR F4h. UARTA 9bit-mode Slave Mask Address Register

Location: Address F4h

Attribute: Read/Write

Power Well: VCC

Reset by: LRESET#

Default : FFh

Size: 8 bits

BIT	READ / WRITE	DESCRIPTION
7-0	R / W	Slave mask address

CR F5h. UARTA 9bit-mode Broadcase Address Register

Location: Address F5h

Attribute: Read/Write



Power Well: VCC

Reset by: LRESET#

Default : FFh

Size: 8 bits

BIT	READ / WRITE	DESCRIPTION
7-0	R / W	Broadcase Address

CR F6h. UARTA 9bit-mode Interrupt Control Register

Location: Address F6h

Attribute: Read/Write

Power Well: VCC

Reset by: LRESET#

Default : 02h

Size: 8 bits

BIT	READ / WRITE	DESCRIPTION
7-2	Reserved.	
1	R / W	IRQ_type_sel 0: 9bitemode RX block function will issue an IRQ when receive any address byte. (when IRQ_addr_Enable bit = 1) 1: 9bitemode RX block function will issue an IRQ when only receive the matched address byte. (when IRQ_addr_Enable bit = 1)
0	R / W	IRQ_addr_Enable 0: Disable UARTA 9bit-mode IRQ output. 1: Enalbe UARTA 9bit-mode IRQ output.

CR F7h. UARTA 9bit-mode IRQ Status Register

Location: Address F7h

Attribute: Read/Write

Power Well: VCC

Reset by: LRESET#

Default : 00h

Size: 8 bits

BIT	READ / WRITE	DESCRIPTION
7-1	Reserved.	
0	R / W	UARTA 9bit-mode Status Bit 0: UARTA 9bit-mode IRQ have not been triggered. 1: UARTA 9bit-mode IRQ have been triggered.

CR F8h. Extending UARTA Control Register

Location: Address F8h

Attribute: Read/Write

Power Well: VCC



Reset by: LRESET#

Default : 00h

Size: 8 bits

BIT	7	6	5	4	3	2	1	0
NAME	fifo_level_mode		Reserved	uartAB_switch_enable	Reserved <i>(All should be set to 0)</i>			Enable_128_bytes_fifo
DEFAULT	0	0	0	0	0	0	0	0

BIT	DESCRIPTION																																															
7-6	fifo_level_mode: (Also check UFR register B7-6 definition)																																															
	<table border="1"> <thead> <tr> <th colspan="7">RX FIFO INTERRUPT ACTIVE LEVEL (BYTES)</th> </tr> <tr> <th>UFR_BIT 7</th> <th>UFR_BIT 6</th> <th>FIFO_LEVEL_MODE (CRF8_B7:6 = 00)</th> <th>FIFO_LEVEL_MODE (CRF8_B7:6 = 01)</th> <th>FIFO_LEVEL_MODE (CRF8_B7:6 = 10)</th> <th>FIFO_LEVEL_MODE (CRF8_B7:6 = 11)</th> <th></th> </tr> </thead> <tbody> <tr> <td>0</td> <td>0</td> <td>01</td> <td>16</td> <td>80</td> <td>112</td> <td></td> </tr> <tr> <td>0</td> <td>1</td> <td>04</td> <td>32</td> <td>88</td> <td>116</td> <td></td> </tr> <tr> <td>1</td> <td>0</td> <td>08</td> <td>48</td> <td>96</td> <td>120</td> <td></td> </tr> <tr> <td>1</td> <td>1</td> <td>14</td> <td>64</td> <td>104</td> <td>124</td> <td></td> </tr> </tbody> </table>						RX FIFO INTERRUPT ACTIVE LEVEL (BYTES)							UFR_BIT 7	UFR_BIT 6	FIFO_LEVEL_MODE (CRF8_B7:6 = 00)	FIFO_LEVEL_MODE (CRF8_B7:6 = 01)	FIFO_LEVEL_MODE (CRF8_B7:6 = 10)	FIFO_LEVEL_MODE (CRF8_B7:6 = 11)		0	0	01	16	80	112		0	1	04	32	88	116		1	0	08	48	96	120		1	1	14	64	104	124	
RX FIFO INTERRUPT ACTIVE LEVEL (BYTES)																																																
UFR_BIT 7	UFR_BIT 6	FIFO_LEVEL_MODE (CRF8_B7:6 = 00)	FIFO_LEVEL_MODE (CRF8_B7:6 = 01)	FIFO_LEVEL_MODE (CRF8_B7:6 = 10)	FIFO_LEVEL_MODE (CRF8_B7:6 = 11)																																											
0	0	01	16	80	112																																											
0	1	04	32	88	116																																											
1	0	08	48	96	120																																											
1	1	14	64	104	124																																											
5	Reserved.																																															
4	uartAB_switch_enable (Bypass mode) 0: switch disable 1: switch enable																																															
3-1	Reserved. <i>(All should be set to 0)</i>																																															
0	Extending fifo enable bit: 0: Disable128bytes TX and RX FIFO. 1: Enable128bytes TX and RX FIFO.																																															



23.5 Logical Device 3 (UARTB)

CR 30h.

Location: Address 30h

Attribute: Read/Write

Power Well: VCC

Reset by: LRESET#

Default : 01h

Size: 8 bits

BIT	READ / WRITE	DESCRIPTION
7-1		Reserved.
0	R / W	0: The logical device is inactive. 1: The logical device is active.

CR 60h, 61h.

Location: Address 60h, 61h

Attribute: Read/Write

Power Well: VCC

Reset by: LRESET#

Default : 02h, F8h

Size: 16 bits

BIT	READ / WRITE	DESCRIPTION
7-0	R / W	These two registers select IR I/O base address <100h: FF8h> on eight-byte boundary.

CR 70h.

Location: Address 70h

Attribute: Read/Write

Power Well: VCC

Reset by: LRESET#

Default : 03h

Size: 8 bits

BIT	READ / WRITE	DESCRIPTION
7-4		Reserved.
3-0	R / W	These bits select IRQ resource for Serial Port 2.

CR F0h.

Location: Address F0h

Attribute: Read/Write

Power Well: VCC

Reset by: LRESET#

Default : 00h

Size: 8 bits



BIT	READ / WRITE	DESCRIPTION
7	R / W	0: Delay RXCLK for 5 ns for LG issue. 1: No delay of 5 ns for RXCLK.
6	R / W	0: IRQ is the level mode. 1: IRQ is the pulse mode for IRQ sharing function.
5	R / W	0: Using the original RX FIFO Error Indication signal (USR bit 7). 1: Using new RX FIFO Error Indication signal to solve some issues.
4-2	Reserved.	
1-0	R / W	Bits 1 0 0 0: UART B clock source is 1.8462 MHz (24 MHz / 13). 0 1: UART B clock source is 2 MHz (24 MHz / 12). 0 0: UART B clock source is 24 MHz (24 MHz / 1). 0 0: UART B clock source is 14.769 MHz (24 MHz / 1.625).

CR F2h. UARTB 9bit-mode Config Register

Location: Address F2h

Attribute: Read/Write

Power Well: VCC

Reset by: LRESET#

Default : 00h

Size: 8 bits

BIT	READ / WRITE	DESCRIPTION
7	R / W	En_auto_RX_ctrl 0: 9bitmode RX block function will pass all data or address byte and not compare any address byte. 1: 9bitmode RX block function could only receive address byte and compare the address bytes. (The address matched or not will issue IRQ. Refer to CRF6 description)
6	R / W	En_auto_only_addr_comp 0: When setting en_auto_RX_ctrl =1'b1, 9bitmode RX block function will compare the address byte and update the RX_ctrl Bit automatically. 1: When setting en_auto_RX_ctrl =1'b1, 9bitmode RX block function will only compare the address byte. But the RX_ctrl Bit will not be updated automatically by 9bitmode RX block function.
5	R / W	RST_low_time_sel 0: TX block will keep 1 bit time before inverting the driving signal. 1: TX block will keep 2 bit time before inverting the driving signal.
4	R / W	RS485_RTS_inv_sel 0: Automatic drive RTS# low when receiving data. Automatic drive RTS# high when transmitting data. 1: Automatic drive RTS# high when receiving data. Automatic drive RTS# low when transmitting data.



BIT	READ / WRITE	DESCRIPTION
3	R / W	En_auto_TX_ctrl 0: En_address_byte bit will not be automatic updated to "logic 0" by hardware after TX block sent address byte. 1: En_address_byte bit will be automatic updated to "logic 0" by hardware after TX block sent address byte.
2	R / W	En_auto_RX_ctrl 0: the address byte will be ingored by the receiver. 1: the address byte will be received into RX FIFO by the receiver.
1	R / W	En_RS485_RTS 0: RS232 driver 1: RS485 driver The 9bitmode TX block function will drive RTS_L to high when transmit data automatically
0	R / W	En_9bit_mode 0: normal UART function. 1: enable 9-bit mode function. (9bit-TX block use parity bit as address/Data bit when setting En_9bit_mode = 1'b1.)

CR F3h. UARTB 9bit-mode Slave Address Register

Location: Address F3h

Attribute: Read/Write

Power Well: VCC

Reset by: LRESET#

Default : 00h

Size: 8 bits

BIT	READ / WRITE	DESCRIPTION
7-0	R / W	Slave address

CR F4h. UARTB 9bit-mode Slave Mask Address Register

Location: Address F4h

Attribute: Read/Write

Power Well: VCC

Reset by: LRESET#

Default : FFh

Size: 8 bits

BIT	READ / WRITE	DESCRIPTION
7-0	R / W	Slave mask address

CR F5h. UARTB 9bit-mode Broadcase Address Register

Location: Address F5h

Attribute: Read/Write



Power Well: VCC

Reset by: LRESET#

Default : FFh

Size: 8 bits

BIT	READ / WRITE	DESCRIPTION
7-0	R / W	Broadcase Address

CR F6h. UARTB 9bit-mode Interrupt Control Register

Location: Address F6h

Attribute: Read/Write

Power Well: VCC

Reset by: LRESET#

Default : 02h

Size: 8 bits

BIT	READ / WRITE	DESCRIPTION
7-2	Reserved.	
1	R / W	IRQ_type_sel 0: 9bitemode RX block function will issue an IRQ when receive any address byte. (when IRQ_addr_Enable bit = 1) 1: 9bitemode RX block function will issue an IRQ when only receive the matched address byte. (when IRQ_addr_Enable bit = 1)
0	R / W	IRQ_addr_Enable 0: Disable UARTB 9bit-mode IRQ output. 1: Enalbe UARTB 9bit-mode IRQ output.

CR F7h. UARTB 9bit-mode IRQ Status Register

Location: Address F7h

Attribute: Read/Write

Power Well: VCC

Reset by: LRESET#

Default : 00h

Size: 8 bits

BIT	READ / WRITE	DESCRIPTION
7-1	Reserved.	
0	R / W	UARTB 9bit-mode Status Bit 0: UARTB 9bit-mode IRQ have not been triggered. 1: UARTB 9bit-mode IRQ have been triggered.

CR F8h. Extending UARTB Control Register

Location: Address F8h

Attribute: Read/Write

Power Well: VCC



Reset by: LRESET#

Default : 00h

Size: 8 bits

BIT	7	6	5	4	3	2	1	0
NAME	fifo_level_mode		Reserved		Reserved <i>(All should be set to 0)</i>			Enable_128_bytes_fifo
DEFAULT	0	0	0	0	0	0	0	0

BIT	DESCRIPTION																																									
7-6	fifo_level_mode: (Also check UFR register B7-6 definition)																																									
	<table border="1"> <thead> <tr> <th colspan="2"></th> <th colspan="4">RX FIFO INTERRUPT ACTIVE LEVEL (BYTES)</th> </tr> <tr> <th>UFR_BIT 7</th> <th>UFR_BIT 6</th> <th>FIFO_LEVEL_MODE (CRF8_B7:6 = 00)</th> <th>FIFO_LEVEL_MODE (CRF8_B7:6 = 01)</th> <th>FIFO_LEVEL_MODE (CRF8_B7:6 = 10)</th> <th>FIFO_LEVEL_MODE (CRF8_B7:6 = 11)</th> </tr> </thead> <tbody> <tr> <td>0</td> <td>0</td> <td>01</td> <td>16</td> <td>80</td> <td>112</td> </tr> <tr> <td>0</td> <td>1</td> <td>04</td> <td>32</td> <td>88</td> <td>116</td> </tr> <tr> <td>1</td> <td>0</td> <td>08</td> <td>48</td> <td>96</td> <td>120</td> </tr> <tr> <td>1</td> <td>1</td> <td>14</td> <td>64</td> <td>104</td> <td>124</td> </tr> </tbody> </table>								RX FIFO INTERRUPT ACTIVE LEVEL (BYTES)				UFR_BIT 7	UFR_BIT 6	FIFO_LEVEL_MODE (CRF8_B7:6 = 00)	FIFO_LEVEL_MODE (CRF8_B7:6 = 01)	FIFO_LEVEL_MODE (CRF8_B7:6 = 10)	FIFO_LEVEL_MODE (CRF8_B7:6 = 11)	0	0	01	16	80	112	0	1	04	32	88	116	1	0	08	48	96	120	1	1	14	64	104	124
		RX FIFO INTERRUPT ACTIVE LEVEL (BYTES)																																								
UFR_BIT 7	UFR_BIT 6	FIFO_LEVEL_MODE (CRF8_B7:6 = 00)	FIFO_LEVEL_MODE (CRF8_B7:6 = 01)	FIFO_LEVEL_MODE (CRF8_B7:6 = 10)	FIFO_LEVEL_MODE (CRF8_B7:6 = 11)																																					
0	0	01	16	80	112																																					
0	1	04	32	88	116																																					
1	0	08	48	96	120																																					
1	1	14	64	104	124																																					
5-4	Reserved.																																									
3-1	Reserved. <i>(All should be set to 0)</i>																																									
0	Extending fifo enable bit: 0: Disable 128bytes TX and RX FIFO. 1: Enable 128bytes TX and RX FIFO.																																									



23.6 Logical Device 5 (KBC)

CR 30h.

Location: Address 30h

Attribute: Read/Write

Power Well: VCC

Reset by: LRESET#

Default : 00h

Size: 8 bits

BIT	READ / WRITE	DESCRIPTION
7-1		Reserved.
0	R / W	0: The logical device is inactive. 1: The logical device is active.

CR 60h, 61h.

Location: Address 60h, 61h

Attribute: Read/Write

Power Well: VCC

Reset by: LRESET#

Default : 00h, 00h

Size: 16 bits

BIT	READ / WRITE	DESCRIPTION
7-0	R / W	These two registers select the first KBC I/O base address <100h: FFFh> on 1-byte boundary.

CR 62h, 63h.

Location: Address 62h, 63h

Attribute: Read/Write

Power Well: VCC

Reset by: LRESET#

Default : 00h, 00h

Size: 16 bits

BIT	READ / WRITE	DESCRIPTION
7-0	R / W	These two registers select the second KBC I/O base address <100h: FFFh> on 1 byte boundary.

CR 70h.

Location: Address 70h

Attribute: Read/Write

Power Well: VCC

Reset by: LRESET#

Default : 00h

Size: 8 bits



BIT	READ / WRITE	DESCRIPTION
7-4	Reserved.	
3-0	R / W	These bits select IRQ resource for KINT. (Keyboard interrupt)

CR 72h.

Location: Address 72h

Attribute: Read/Write

Power Well: VCC

Reset by: LRESET#

Default : 00h

Size: 8 bits

BIT	READ / WRITE	DESCRIPTION
7-4	Reserved.	
3-0	R / W	These bits select IRQ resource for MINT. (PS/2 Mouse interrupt)

CR F0h.

Location: Address F0h

Attribute: Read/Write

Power Well: VCC

Reset by: LRESET#

Default : 83h

Size: 8 bits

BIT	READ / WRITE	DESCRIPTION
7-6	R / W	KBC clock rate selection Bits 7 6 0 0: Reserved 0 1: Reserved 1 0: 12MHz 1 1: Reserved
5-3	Reserved.	
2	R / W	0: Port 92 disabled. 1: Port 92 enabled.
1	R / W	0: Gate A20 software control. 1: Gate A20 hardware speed up.
0	R / W	0: KBRST# software control. 1: KBRST# hardware speed up.



23.7 Logical Device 6 (CIR)

CR 30h.

Location: Address 30h

Attribute: Read/Write

Power Well: VCC

Reset by: LRESET#

Default : 00h

Size: 8 bits

BIT	READ / WRITE	DESCRIPTION
7-1	Reserved.	
0	R / W	0: CIR Interface is inactive. 1: CIR Interface is active.

CR 60h, 61h.

Location: Address 60h, 61h

Attribute: Read/Write

Power Well: VCC

Reset by: LRESET#

Default : 00h, 00h

Size: 16 bits

BIT	READ / WRITE	DESCRIPTION
7-0	R / W	These two registers select CIR Interface I/O base address <100h: FF8h> on 1 byte boundary.

CR 70h.

Location: Address 70h

Attribute: Read/Write

Power Well: VCC

Reset by: LRESET#

Default : 00h

Size: 8 bits

BIT	READ / WRITE	DESCRIPTION
7-4	Reserved.	
3-0	R / W	These bits select IRQ resource for CIR.

CR F0h.

Location: Address F0h

Attribute: Read/Write

Power Well: VCC

Reset by: LRESET#

Default : 08h

Size: 8 bits



BIT	READ / WRITE	DESCRIPTION
7-4	Reserved.	
3	R/W	CIR wide band filter select 0: Low-pass filter 1: Band-pass filter
2-1	R/W	Timeout margin selection of CIR wide band band-pass filter 00: 200% recording carrier period 01: 100% recording carrier period 10: 50% recording carrier period 11: 25% recording carrier period
0	R/W	Carrier recording mode CIR wide band band-pass filter 0: Second carrier 1: Every carrier

CR F1h.

Location: Address F1h

Attribute: Read/Write

Power Well: VCC

Reset by: LRESET#

Default : 09h

Size: 8 bits

BIT	READ / WRITE	DESCRIPTION
7-6	R / W	Reserved.
5-0	R / W	Highest input period of CIR wide band band-pass filter (unit : us)

CR F2h.

Location: Address F2h

Attribute: Read/Write

Power Well: VCC

Reset by: LRESET#

Default : 32h

Size: 8 bits

BIT	READ / WRITE	DESCRIPTION
7-6	R / W	Reserved.
5-0	R / W	Lowest input period of CIR wide band band-pass filter (unit : us)

CR F3h.

Location: Address F3h

Attribute: Read/Write

Power Well: VCC

Reset by: LRESET#

Default : 00h

Size: 8 bits

BIT	READ / WRITE	DESCRIPTION
7-6	R / W	Reserved.
5-0	R / W	Recording carrier period of CIR wide band band-pass filter (unit : us)



23.8 Logical Device 7 (GPIO)

CR 30h.

Location: Address 30h

Attribute: Read/Write

Power Well: VSB

Reset by: RSMRST#, LRESET# (Bit2)

Default : DFh

Size: 8 bits

BIT	READ / WRITE	DESCRIPTION	
7	R / W	0: GPIO7 is inactive.	1: GPIO7 is active.
6	R / W	0: GPIO6 is inactive.	1: GPIO6 is active.
5	R / W	0: GPIO5 is inactive.	1: GPIO5 is active.
4	R / W	0: GPIO4 is inactive.	1: GPIO4 is active.
3	R / W	0: GPIO3 is inactive.	1: GPIO3 is active.
2	R / W	0: GPIO2 is inactive.	1: GPIO2 is active.
1	R / W	0: GPIO1 is inactive.	1: GPIO1 is active.
0	R / W	0: GPIO0 is inactive.	1: GPIO0 is active.

CR E0h. GPIO0 I/O Register

Location: Address E0h

Attribute: Read/Write

Power Well: VSB

Reset by: GP0X_MRST

Default : FFh

Size: 8 bits

BIT	READ / WRITE	DESCRIPTION
7-0	R / W	GPIO0 I/O register 0: The respective GPIO0 PIN is programmed as an output port 1: The respective GPIO0 PIN is programmed as an input port.

CR E1h. GPIO0 Data Register

Location: Address E1h

Attribute: Read/Write

Power Well: VSB

Reset by: GP0X_MRST

Default : 00h

Size: 8 bits

BIT	READ / WRITE	DESCRIPTION
7-0	R / W	GPIO0 Data register For output ports, the respective bits can be read/written and produced to pins.



BIT	READ / WRITE	DESCRIPTION
	Read Only	For input ports, the respective bits can be read only from pins. Write accesses will be ignored.

CR E2h. GPIO0 Inversion Register

Location: Address E2h

Attribute: Read/Write

Power Well: VSB

Reset by: GP0X_MRST

Default : 00h

Size: 8 bits

BIT	READ / WRITE	DESCRIPTION
7-0	R / W	GPIO0 Inversion register 0: The respective bit and the port value are the same. 1: The respective bit and the port value are inverted. (Both Input & Output ports)

CR E3h. GPIO0 Status Register

Location: Address E3h

Attribute: Read Only

Power Well: VSB

Reset by: GP0X_MRST

Default : 00h

Size: 8 bits

BIT	READ / WRITE	DESCRIPTION
7-0	Read Only Read-Clear	GPIO0 Event Status Bit 7-0 corresponds to GP07-GP00, respectively. 0 : No active edge (rising/falling) has been detected 1 : An active edge (rising/falling) has been detected Read the status bit clears it to 0.

CR E4h. GPIO1 I/O Register

Location: Address E4h

Attribute: Read/Write

Power Well: VSB

Reset by: GP1X_MRST

Default : FFh

Size: 8 bits

BIT	READ / WRITE	DESCRIPTION
7-0	R / W	GPIO1 I/O register 0: The respective GPIO1 PIN is programmed as an output port 1: The respective GPIO1 PIN is programmed as an input port.

**CR E5h. GPIO1 Data Register**

Location: Address E5h

Attribute: Read/Write

Power Well: VSB

Reset by: GP1X_MRST

Default : 00h

Size: 8 bits

BIT	READ / WRITE	DESCRIPTION
7-0	R / W	GPIO1 Data register For output ports, the respective bits can be read/written and produced to pins.
	Read Only	For input ports, the respective bits can be read only from pins. Write accesses will be ignored.

CR E6h. GPIO1 Inversion Register

Location: Address E6h

Attribute: Read/Write

Power Well: VSB

Reset by: GP1X_MRST

Default : 00h

Size: 8 bits

BIT	READ / WRITE	DESCRIPTION
7-0	R / W	GPIO1 Inversion register 0: The respective bit and the port value are the same. 1: The respective bit and the port value are inverted. (Both Input & Output ports)

CR E7h. GPIO1 Status Register

Location: Address E7h

Attribute: Read Only

Power Well: VSB

Reset by: GP0X_MRST

Default : 00h

Size: 8 bits

BIT	READ / WRITE	DESCRIPTION
7-0	Read Only Read-Clear	GPIO1 Event Status Bit 7-0 corresponds to GP17-GP10, respectively. 0 : No active edge (rising/falling) has been detected 1 : An active edge (rising/falling) has been detected Read the status bit clears it to 0.

CR E8h. GPIO2 I/O Register

Location: Address E8h

Attribute: Read/Write



Power Well: VCC
 Reset by: GP2X_MRST
 Default : FFh
 Size: 8 bits

BIT	READ / WRITE	DESCRIPTION
7-0	R / W	GPIO2 I/O register 0: The respective GPIO2 PIN is programmed as an output port 1: The respective GPIO2 PIN is programmed as an input port.

CR E9h. GPIO2 Data Register

Location: Address E9h
 Attribute: Read/Write
 Power Well: VCC
 Reset by: GP2X_MRST
 Default : 00h
 Size: 8 bits

BIT	READ / WRITE	DESCRIPTION
7-0	R / W	GPIO2 Data register For output ports, the respective bits can be read/written and produced to pins.
	Read Only	For input ports, the respective bits can be read only from pins. Write accesses will be ignored.

CR EAh. GPIO2 Inversion Register

Location: Address EAh
 Attribute: Read/Write
 Power Well: VCC
 Reset by: GP2X_MRST
 Default : 00h
 Size: 8 bits

BIT	READ / WRITE	DESCRIPTION
7-0	R / W	GPIO2 Inversion register 0: The respective bit and the port value are the same. 1: The respective bit and the port value are inverted. (Both Input & Output ports)

CR EBh. GPIO2 Status Register

Location: Address EBh
 Attribute: Read Only
 Power Well: VCC
 Reset by: GP2X_MRST
 Default : 00h
 Size: 8 bits



BIT	READ / WRITE	DESCRIPTION
7-0	Read Only Read-Clear	GPIO2 Event Status Bit 7-0 corresponds to GP27-GP20, respectively. 0 : No active edge (rising/falling) has been detected 1 : An active edge (rising/falling) has been detected Read the status bit clears it to 0.

CR ECh. GPIO3 I/O Register

Location: Address ECh

Attribute: Read/Write

Power Well: VSB

Reset by: GP3X_MRST

Default : FFh

Size: 8 bits

BIT	READ / WRITE	DESCRIPTION
7-0	R / W	GPIO3 I/O register 0: The respective GPIO3 PIN is programmed as an output port 1: The respective GPIO3 PIN is programmed as an input port.

CR EDh. GPIO3 Data Register

Location: Address EDh

Attribute: Read/Write

Power Well: VSB

Reset by: GP3X_MRST

Default : 00h

Size: 8 bits

BIT	READ / WRITE	DESCRIPTION
7-0	R / W	GPIO3 Data register For output ports, the respective bits can be read/written and produced to pins.
	Read Only	For input ports, the respective bits can be read only from pins. Write accesses will be ignored.

CR EEh. GPIO3 Inversion Register

Location: Address EEh

Attribute: Read/Write

Power Well: VSB

Reset by: GP3X_MRST

Default : 00h

Size: 8 bits

BIT	READ / WRITE	DESCRIPTION
-----	--------------	-------------



BIT	READ / WRITE	DESCRIPTION
7-0	R / W	GPIO3 Inversion register 0: The respective bit and the port value are the same. 1: The respective bit and the port value are inverted. (Both Input & Output ports)

CR EFh. GPIO3 Status Register

Location: Address EFh

Attribute: Read Only

Power Well: VSB

Reset by: GP3X_MRST

Default : 00h

Size: 8 bits

BIT	READ / WRITE	DESCRIPTION
7-0	Read Only Read-Clear	GPIO3 Event Status Bit 7-0 corresponds to GP37-GP30, respectively. 0 : No active edge (rising/falling) has been detected 1 : An active edge (rising/falling) has been detected Read the status bit clears it to 0.

CR F0h. GPIO4 I/O Register

Location: Address F0h

Attribute: Read/Write

Power Well: VSB

Reset by: GP4X_MRST

Default : FFh

Size: 8 bits

BIT	READ / WRITE	DESCRIPTION
7-0	R / W	GPIO4 I/O register 0: The respective GPIO4 PIN is programmed as an output port 1: The respective GPIO4 PIN is programmed as an input port.

CR F1h. GPIO4 Data Register

Location: Address F1h

Attribute: Read/Write

Power Well: VSB

Reset by: GP4X_MRST

Default : 00h

Size: 8 bits

BIT	READ / WRITE	DESCRIPTION
7-0	R / W	GPIO4 Data register For output ports, the respective bits can be read/written and produced to pins.



BIT	READ / WRITE	DESCRIPTION
	Read Only	For input ports, the respective bits can be read only from pins. Write accesses will be ignored.

CR F2h. GPIO4 Inversion Register

Location: Address F2h

Attribute: Read/Write

Power Well: VSB

Reset by: GP4X_MRST

Default : 00h

Size: 8 bits

BIT	READ / WRITE	DESCRIPTION
7-0	R / W	GPIO4 Inversion register 0: The respective bit and the port value are the same. 1: The respective bit and the port value are inverted. (Both Input & Output ports)

CR F3h. GPIO4 Status Register

Location: Address F3h

Attribute: Read Only

Power Well: VSB

Reset by: GP4X_MRST

Default : 00h

Size: 8 bits

BIT	READ / WRITE	DESCRIPTION
7-0	Read Only Read-Clear	GPIO4 Event Status Bit 7-0 corresponds to GP47-GP40, respectively. 0 : No active edge (rising/falling) has been detected 1 : An active edge (rising/falling) has been detected Read the status bit clears it to 0.

CR F4h. GPIO5 I/O Register

Location: Address F4h

Attribute: Read/Write

Power Well: VSB

Reset by: GP5X_MRST

Default : FFh

Size: 8 bits

BIT	READ / WRITE	DESCRIPTION
7-0	R / W	GPIO5 I/O register 0: The respective GPIO5 PIN is programmed as an output port 1: The respective GPIO5 PIN is programmed as an input port.

**CR F5h. GPIO5 Data Register**

Location: Address F5h

Attribute: Read/Write

Power Well: VSB

Reset by: GP5X_MRST

Default : 00h

Size: 8 bits

BIT	READ / WRITE	DESCRIPTION
7-0	R / W	GPIO5 Data register For output ports, the respective bits can be read/written and produced to pins.
	Read Only	For input ports, the respective bits can be read only from pins. Write accesses will be ignored.

CR F6h. GPIO5 Inversion Register

Location: Address F6h

Attribute: Read/Write

Power Well: VSB

Reset by: GP5X_MRST

Default : 00h

Size: 8 bits

BIT	READ / WRITE	DESCRIPTION
7-0	R / W	GPIO5 Inversion register 0: The respective bit and the port value are the same. 1: The respective bit and the port value are inverted. (Both Input & Output ports)

CR F7h. GPIO5 Status Register

Location: Address F7h

Attribute: Read Only

Power Well: VSB

Reset by: GP5X_MRST

Default : 00h

Size: 8 bits

BIT	READ / WRITE	DESCRIPTION
7-0	Read Only Read-Clear	GPIO5 Event Status Bit 7-0 corresponds to GP57-GP50, respectively. 0 : No active edge (rising/falling) has been detected 1 : An active edge (rising/falling) has been detected Read the status bit clears it to 0.

CR F8h. GPIO6 I/O Register

Location: Address F8h

Attribute: Read/Write



Power Well: VSB
 Reset by: GP6X_MRST
 Default : FFh
 Size: 8 bits

BIT	READ / WRITE	DESCRIPTION
7-0	R / W	GPIO6 I/O register 0: The respective GPIO6 PIN is programmed as an output port 1: The respective GPIO6 PIN is programmed as an input port.

CR F9h. GPIO6 Data Register

Location: Address F9h
 Attribute: Read/Write
 Power Well: VSB
 Reset by: GP6X_MRST
 Default : 00h
 Size: 8 bits

BIT	READ / WRITE	DESCRIPTION
7-0	R / W	GPIO6 Data register For output ports, the respective bits can be read/written and produced to pins.
	Read Only	For input ports, the respective bits can be read only from pins. Write accesses will be ignored.

CR FAh. GPIO6 Inversion Register

Location: Address FAh
 Attribute: Read/Write
 Power Well: VSB
 Reset by: GP6X_MRST
 Default : 00h
 Size: 8 bits

BIT	READ / WRITE	DESCRIPTION
7-0	R / W	GPIO6 Inversion register 0: The respective bit and the port value are the same. 1: The respective bit and the port value are inverted. (Both Input & Output ports)

CR FBh. GPIO6 Status Register

Location: Address FBh
 Attribute: Read Only
 Power Well: VSB
 Reset by: GP6X_MRST
 Default : 00h
 Size: 8 bits



BIT	READ / WRITE	DESCRIPTION
7-0	Read Only Read-Clear	GPIO6 Event Status Bit 7-0 corresponds to GP67-GP60, respectively. 0 : No active edge (rising/falling) has been detected 1 : An active edge (rising/falling) has been detected Read the status bit clears it to 0.

CR FCh. GPIO7 I/O Register

Location: Address FCh

Attribute: Read/Write

Power Well: VSB

Reset by: GP7X_MRST

Default : 02h

Size: 8 bits

BIT	READ / WRITE	DESCRIPTION
7-2	Reserved.	
1	R / W	GPIO7 I/O register 0: The respective GPIO7 PIN is programmed as an output port 1: The respective GPIO7 PIN is programmed as an input port.
0	Reserved.	

CR FDh. GPIO7 Data Register

Location: Address FDh

Attribute: Read/Write

Power Well: VSB

Reset by: GP7X_MRST

Default : 00h

Size: 8 bits

BIT	READ / WRITE	DESCRIPTION
7-2	Reserved.	
1	R / W	GPIO7 Data register For output ports, the respective bits can be read/written and produced to pins.
	Read Only	For input ports, the respective bits can be read only from pins. Write accesses will be ignored.
0	Reserved.	

CR FEh. GPIO7 Inversion Register

Location: Address FEh

Attribute: Read/Write

Power Well: VSB

Reset by: GP7X_MRST



Default : 00h

Size: 8 bits

BIT	READ / WRITE	DESCRIPTION
7-1	Reserved.	
1	R / W	GPIO7 Inversion register 0: The respective bit and the port value are the same. 1: The respective bit and the port value are inverted. (Both Input & Output ports)
0	Reserved.	

CR FFh. GPIO7 Status Register

Location: Address FFh

Attribute: Read Only

Power Well: VSB

Reset by: GP7X_MRST

Default : 00h

Size: 8 bits

BIT	READ / WRITE	DESCRIPTION
7-2	Reserved.	
1	Read Only Read-Clear	GPIO7 Event Status Bit 1 corresponds to GP71. 0 : No active edge (rising/falling) has been detected 1 : An active edge (rising/falling) has been detected Read the status bit clears it to 0.
0	Reserved.	



23.9 Logical Device 8 (GPIO, WDT1)

CR 30h.

Location: Address 30h

Attribute: Read/Write

Power Well: VCC

Reset by: LRESET#

Default : 01h

Size: 8 bits

BIT	READ / WRITE	DESCRIPTION
7-2		Reserved.
1	R / W	0: GPIO Base Address mode is inactive 1: GPIO Base Address mode is active
0	R / W	0: WDT1 is inactive. 1: WDT1 is active.

CR 60h, 61h.

Location: Address 60h, 61h

Attribute: Read/Write

Power Well: VCC

Reset by: LRESET#

Default : 00h, 00h

Size: 16 bits

BIT	READ / WRITE	DESCRIPTION
7-0	R / W	These two registers select GPIO Interface I/O base address <100h: FF8h> on 1 byte boundary.

CR E0h. GPIO0 Multi-function Select Register

Location: Address E0h

Attribute: Read/Write

Power Well: VSB

Reset by: GP0X_MRST

Default : 00h

Size: 8 bits

BIT	READ / WRITE	DESCRIPTION
7	R / W	0: GPIO07 1: GPIO07 → YLW
6	R / W	0: GPIO06 1: GPIO06 → GRN
5	R / W	0: GPIO05 1: GPIO05 → WDT0#
4	R / W	0: GPIO04 1: GPIO04 → SUSLED



BIT	READ / WRITE	DESCRIPTION
3	R / W	0: GPIO03 1: GPIO03 → YLW
2	R / W	0: GPIO02 1: GPIO02 → GRN
1	R / W	0: GPIO01 1: GPIO01 → WDTO#
0	R / W	0: GPIO00 1: GPIO00 → SUSLED

CR E1h. GPIO1 Multi-function Select Register

Location: Address E1h

Attribute: Read/Write

Power Well: VSB

Reset by: GP1X_MRST

Default : 00h

Size: 8 bits

BIT	READ / WRITE	DESCRIPTION
7	R / W	0: GPIO17 1: GPIO17 → YLW
6	R / W	0: GPIO16 1: GPIO16 → GRN
5	R / W	0: GPIO15 1: GPIO15 → BEEP
4	R / W	0: GPIO14 1: GPIO14 → SMI
3	R / W	0: GPIO13 1: GPIO13 → YLW
2	R / W	0: GPIO12 1: GPIO12 → GRN
1	R / W	0: GPIO11 1: GPIO11 → BEEP
0	R / W	0: GPIO10 1: GPIO10 → SMI

CR E2h. GPIO2 Multi-function Select Register

Location: Address E2h

Attribute: Read/Write

Power Well: VCC

Reset by: GP2X_MRST

Default : 00h

Size: 8 bits



BIT	READ / WRITE	DESCRIPTION
7	R / W	0: GPIO27 1: GPIO27 → WDTO#
6	R / W	0: GPIO26 1: GPIO26 → BEEP
5	R / W	0: GPIO25 1: GPIO25 → SMI
4	R / W	0: GPIO24 1: GPIO24 → PLED
3	R / W	0: GPIO23 1: GPIO23 → WDTO#
2	R / W	0: GPIO22 1: GPIO22 → BEEP
1	R / W	0: GPIO21 1: GPIO21 → SMI
0	R / W	0: GPIO20 1: GPIO20 → PLED

CR E3h. GPIO3 Multi-function Select Register

Location: Address E3h

Attribute: Read/Write

Power Well: VSB

Reset by: GP3X_MRST

Default : 00h

Size: 8 bits

BIT	READ / WRITE	DESCRIPTION
7	R / W	0: GPIO37 1: GPIO37 → BEEP
6	R / W	0: GPIO36 1: GPIO36 → SMI
5	R / W	0: GPIO35 1: GPIO35 → WDTO#
4	R / W	0: GPIO34 1: GPIO34 → SUSLED
3	R / W	0: GPIO33 1: GPIO33 → BEEP
2	R / W	0: GPIO32 1: GPIO32 → SMI
1	R / W	0: GPIO31 1: GPIO31 → WDTO#



BIT	READ / WRITE	DESCRIPTION
0	R / W	0: GPIO30 1: GPIO30 → SUSLED

CR E4h. GPIO4 Multi-function Select Register

Location: Address E4h

Attribute: Read/Write

Power Well: VSB

Reset by: GP4X_MRST

Default : 00h

Size: 8 bits

BIT	READ / WRITE	DESCRIPTION
7	R / W	0: GPIO47 1: GPIO47 → YLW
6	R / W	0: GPIO46 1: GPIO46 → GRN
5	R / W	0: GPIO45 1: GPIO45 → PLED
4	R / W	0: GPIO44 1: GPIO44 → SMI
3	R / W	0: GPIO43 1: GPIO43 → YLW
2	R / W	0: GPIO42 1: GPIO42 → GRN
1	R / W	0: GPIO41 1: GPIO41 → PLED
0	R / W	0: GPIO40 1: GPIO40 → SMI

CR E5h. GPIO5 Multi-function Select Register

Location: Address E5h

Attribute: Read/Write

Power Well: VSB

Reset by: GP5X_MRST

Default : 00h

Size: 8 bits

BIT	READ / WRITE	DESCRIPTION
7	R / W	0: GPIO57 1: GPIO57 → YLW
6	R / W	0: GPIO56 1: GPIO56 → GRN



BIT	READ / WRITE	DESCRIPTION
5	R / W	0: GPIO55 1: GPIO55 → BEEP
4	R / W	0: GPIO54 1: GPIO54 → WDTO#
3	R / W	0: GPIO53 1: GPIO53 → YLW
2	R / W	0: GPIO52 1: GPIO52 → GRN
1	R / W	0: GPIO51 1: GPIO51 → BEEP
0	R / W	0: GPIO50 1: GPIO50 → WDTO#

CR E6h. GPIO6 Multi-function Select Register

Location: Address E6h

Attribute: Read/Write

Power Well: VSB

Reset by: GP6X_MRST

Default : 00h

Size: 8 bits

BIT	READ / WRITE	DESCRIPTION
7		Reserved.
6	R / W	0: GPIO66 1: GPIO66 → YLW
5	R / W	0: GPIO65 1: GPIO65 → GRN
4	R / W	0: GPIO64 1: GPIO64 → BEEP
3	R / W	0: GPIO63 1: GPIO63 → SMI
2	R / W	0: GPIO62 1: GPIO62 → WDTO#
1	R / W	0: GPIO61 1: GPIO61 → SUSLED
0	R / W	0: GPIO60 1: GPIO60 → PLED

CR E7h. GPIO6 & GPIO7 Multi-function Select Register

Location: Address E7h

Attribute: Read/Write



Power Well: VSB

Reset by: GP6X_MRST (Bit7-5), GP7X_MRST(Bit3-1)

Default : 00h

Size: 8 bits

BIT	READ / WRITE	DESCRIPTION
7-5	R / W	000: GPIO67 001: GPIO67 → YLW 010: GPIO67 → GRN 011: GPIO67 → BEEP 100: GPIO67 → SMI 101: GPIO67 → WDTO# 110: GPIO67 → SUSLED 111: GPIO67 → PLED
4-1	Reserved.	
0	R / W	0: GPIO71 1: GPIO71 → WDTO#

CR F0h. Watchdog Timer I(WDT1) and KBC P20 Control Mode Register

Location: Address F0h

Attribute: Read/Write

Power Well: VCC

Reset by: LRESET# or PWROK

Default : 00h

Size: 8 bits

BIT	READ / WRITE	DESCRIPTION
7-5	Reserved.	
4	R / W	Watchdog Timer I count mode is 1000 times faster. 0: Disable. 1: Enable. (If bit-3 is 0, the count mode is 1/1000 seconds mode.) (If bit-3 is 1, the count mode is 1/1000 minutes mode.)
3	R / W	Select Watchdog Timer I count mode. 0: Second Mode. 1: Minute Mode.
2	R / W	Enable the rising edge of a KBC reset (P20) to issue a time-out event. 0: Disable. 1: Enable.
1	R / W	Disable / Enable the Watchdog Timer I output low pulse to the KBRST# pin (PIN59) 0: Disable. 1: Enable.
0	Reversed	



CR F1h. Watchdog Timer I(WDT1) Counter Register

Location: Address F1h

Attribute: Read/Write

Power Well: VCC

Reset by: LRESET# or PWROK

Default : 04h

Size: 8 bits

BIT	READ / WRITE	DESCRIPTION
7-0	R / W	<p>Watch Dog Timer I Time-out value. Writing a non-zero value to this register causes the counter to load the value into the Watch Dog Counter and start counting down. If CR F2h, bits 7 and 6 are set, any Mouse Interrupt or Keyboard Interrupt event causes the previously-loaded, non-zero value to be reloaded to the Watch Dog Counter and the count down resumes. Reading this register returns the current value in the Watch Dog Counter, not the Watch Dog Timer Time-out value.</p> <p>00h: Time-out Disable</p> <p>01h: Time-out occurs after 5.03×10^7 CLKIN cycle time, by analogy. $(5.03 \times 10^7 \times (1/48\text{MHz}) = 1.046\text{s})$</p>

CR F2h. Watchdog Timer I(WDT1) Control & Status Register

Location: Address F2h

Attribute: Read/Write

Power Well: VCC

Reset by: LRESET# or PWROK

Default : 00h

Size: 8 bits

BIT	READ / WRITE	DESCRIPTION
7	R / W	<p>Mouse interrupt reset enables watch-dog timer reload</p> <p>0: Watchdog Timer I is not affected by mouse interrupt.</p> <p>1: Watchdog Timer I is reset by mouse interrupt.</p>
6	R / W	<p>Keyboard interrupt reset enables watch-dog timer reload</p> <p>0: Watchdog Timer I is not affected by keyboard interrupt.</p> <p>1: Watchdog Timer I is reset by keyboard interrupt.</p>
5	Write "1" Only	Trigger Watchdog Timer I event. This bit is self-clearing.
4	R / W Write "0" Clear	<p>Watchdog Timer I status bit</p> <p>0: Watchdog Timer I is running.</p> <p>1: Watchdog Timer I issues time-out event.</p>
3-0	R / W	These bits select the IRQ resource for the Watchdog Timer I



23.10 Logical Device 9 (GPIO)

CR E0h. Input Detected Type Register

Location: Address E0h

Attribute: Read/Write

Power Well: VSB CR 20h

Reset by: GP4X_MRST

Default : 00h

Size: 8 bits

BIT	READ / WRITE	DESCRIPTION
7	R / W	0: Enable GP47 input de-bouncer 1: Disable GP47 input de-bouncer
6	R / W	0: Enable GP46 input de-bouncer 1: Disable GP46 input de-bouncer
5	R / W	0: Enable GP45 input de-bouncer 1: Disable GP45 input de-bouncer
4	R / W	0: Enable GP44 input de-bouncer 1: Disable GP44 input de-bouncer
3	R / W	0: GP47 trigger type: edge 1: GP47 trigger type: level
2	R / W	0: GP46 trigger type: edge 1: GP46 trigger type: level
1	R / W	0: GP45 trigger type: edge 1: GP45 trigger type: level
0	R / W	0: GP44 trigger type: edge 1: GP44 trigger type: level

CR E1h. GPIO44, 45, 46 & 47 Event Route Selection Register

Location: Address E1h

Attribute: Read/Write

Power Well: VSB

Reset by: RSMRST#

Default : 00h

Size: 8 bits

BIT	READ / WRITE	DESCRIPTION
7	R / W	0: Disable GP47 event route to PSOUT#. 1: Enable GP47 event route to PSOUT#.
6	R / W	0: Disable GP46 event route to PSOUT#. 1: Enable GP46 event route to PSOUT#.
5	R / W	0: Disable GP45 event route to PSOUT#. 1: Enable GP45 event route to PSOUT#.



BIT	READ / WRITE	DESCRIPTION
4	R / W	0: Disable GP44 event route to PSOUT#. 1: Enable GP44 event route to PSOUT#.
3	R / W	0: Disable GP47 event route to PME#. 1: Enable GP47 event route to PME#.
2	R / W	0: Disable GP46 event route to PME#. 1: Enable GP46 event route to PME#.
1	R / W	0: Disable GP45 event route to PME#. 1: Enable GP45 event route to PME#.
0	R / W	0: Disable GP44 event route to PME#. 1: Enable GP44 event route to PME#.

CR E2h. GPIOs Reset Source Register

Location: Address E2h

Attribute: Read/Write

Power Well: VSB

Reset by: RSMRST#

Default : 00h

Size: 8 bits

BIT	READ / WRITE	DESCRIPTION
7	R / W	GP7X_MRST 0: GP7X reset by RSMRST#. 1: GP7X reset by SLPS5.
6	R / W	GP6X_MRST 0: GP6X reset by RSMRST#. 1: GP6X reset by SLPS5.
5	R / W	GP5X_MRST 0: GP5X reset by RSMRST#. 1: GP5X reset by SLPS5.
4	R / W	GP4X_MRST 0: GP4X reset by RSMRST#. 1: GP4X reset by SLPS5.
3	R / W	GP3X_MRST 0: GP3X reset by RSMRST#. 1: GP3X reset by SLPS5.
2	R / W	GP2X_MRST 0: GP2X reset by LRESET#. 1: GP2X reset by PWROK.
1	R / W	GP1X_MRST 0: GP1X reset by RSMRST#. 1: GP1X reset by SLPS5.
0	R / W	GP0X_MRST 0: GP0X reset by RSMRST#. 1: GP0X reset by SLPS5.



23.11 Logical Device A (ACPI)

CR E0h.

Location: Address E0h

Attribute: Read/Write

Power Well: VRTC

Reset by: Battery reset

Default : 01h

Size: 8 bits

BIT	READ / WRITE	DESCRIPTION																												
7	R / W	DIS_PSIN => Disable the panel switch input to turn on the system power supply. 0: PSIN is wire-AND and connected to PSOUT#. 1: PSIN is blocked and cannot affect PSOUT#.																												
6	R / W	Enable KBC wake-up 0: Disable keyboard wake-up function via PSOUT#. 1: Enable keyboard wake-up function via PSOUT#.																												
5	R / W	Enable Mouse wake-up 0: Disable mouse wake-up function via PSOUT#. 1: Enable mouse wake-up function via PSOUT#.																												
4	R / W	MSRKEY => Three keys (ENMDAT_UP, CRE6[7]; MSRKEY, CRE0[4]; MSXKEY, CRE0[1]) define the combinations of the mouse wake-up events. Please see the following table for the details. <table border="1" style="margin-left: 20px;"> <thead> <tr> <th>ENMDAT_UP</th> <th>MSRKEY</th> <th>MSXKEY</th> <th>Wake-up event</th> </tr> </thead> <tbody> <tr> <td>1</td> <td>x</td> <td>1</td> <td>Any button clicked or any movement.</td> </tr> <tr> <td>1</td> <td>x</td> <td>0</td> <td>One click of left or right button.</td> </tr> <tr> <td>0</td> <td>0</td> <td>1</td> <td>One click of the left button.</td> </tr> <tr> <td>0</td> <td>1</td> <td>1</td> <td>One click of the right button.</td> </tr> <tr> <td>0</td> <td>0</td> <td>0</td> <td>Two clicks of the left button.</td> </tr> <tr> <td>0</td> <td>1</td> <td>0</td> <td>Two clicks of the right button.</td> </tr> </tbody> </table>	ENMDAT_UP	MSRKEY	MSXKEY	Wake-up event	1	x	1	Any button clicked or any movement.	1	x	0	One click of left or right button.	0	0	1	One click of the left button.	0	1	1	One click of the right button.	0	0	0	Two clicks of the left button.	0	1	0	Two clicks of the right button.
ENMDAT_UP	MSRKEY	MSXKEY	Wake-up event																											
1	x	1	Any button clicked or any movement.																											
1	x	0	One click of left or right button.																											
0	0	1	One click of the left button.																											
0	1	1	One click of the right button.																											
0	0	0	Two clicks of the left button.																											
0	1	0	Two clicks of the right button.																											
3	R / W	Enable CIR wake-up 0: Disable CIR wake-up function via PSOUT#. 1: Enable CIR wake-up function via PSOUT#.																												
2	R / W	Keyboard / Mouse swap enable 0: Normal mode. 1: Keyboard / Mouse ports are swapped.																												
1	R / W	MSXKEY => Three keys (ENMDAT_UP, CRE6[7]; MSRKEY, CRE0[4]; MSXKEY, CRE0[1]) define the combinations of the mouse wake-up events. Please check out the table in CRE0[4] for the detailed.																												



BIT	READ / WRITE	DESCRIPTION
0	R / W	KBXKEY => 0: Only the pre-determined key combination in sequence can wake up the system. 1: Any character received from the keyboard can wake up the system.

CR E1h. KBC Wake-Up Index Register

Location: Address E1h

Attribute: Read/Write

Power Well: VSB

Reset by: RSMRST#

Default : 00h

Size: 8 bits

BIT	READ / WRITE	DESCRIPTION
7-0	R / W	Keyboard wake-up index register. This is the index register of CRE2, which is the access window for the keyboard's pre-determined key key-combination characters. The first set of wake-up keys is in of 0x00 – 0x0E, the second set 0x30 – 0x3E, and the third set 0x40 – 0x4E. Incoming key combinations can be read through 0x10 – 0x1E.

CR E2h. KBC Wake-Up Data Register

Location: Address E2h

Attribute: Read/Write

Power Well: VSB

Reset by: RSMRST#

Default : 00h

Size: 8 bits

BIT	READ / WRITE	DESCRIPTION
7-0	R / W	Keyboard wake-up data register. This is the data register for the keyboard's pre-determined key-combination characters, which is indexed by CRE1.

CR E3h. Event Status Register

Location: Address E3h

Attribute: Read Only

Power Well: VRTC

Reset by: Battery reset

Default : 00h

Size: 8 bits

BIT	READ / WRITE	DESCRIPTION
7-5	Reserved.	
4	Read Only Read-Clear	This status flag indicates VSB power off/on.



BIT	READ / WRITE	DESCRIPTION
3	Read Only Read-Clear	Thermal shutdown status. 0: No thermal shutdown event issued. 1: Thermal shutdown event issued.
2	Read Only Read-Clear	PSIN_STS 0: No PSIN event issued. 1: PSIN event issued.
1	Read Only Read-Clear	MSWAKEUP_STS => The bit is latched by the mouse wake-up event. 0: No mouse wake-up event issued. 1: Mouse wake-up event issued.
0	Read Only Read-Clear	KBWAKEUP_STS => The bit is latched by the keyboard wake-up event. 0: No keyboard wake-up event issued. 1: Keyboard wake-up event issued.

CR E4h.

Location: Address E4h

Attribute: Read/Write

Power Well: VRTC

Reset by: Battery reset

Default : 00h

Size: 8 bits

BIT	READ / WRITE	DESCRIPTION
7	Reserved	
6-5	R / W	Power-loss control bits => (VBAT) Bits 6 5 0 0: System always turns off when it returns from power-loss state. 0 1: System always turns on when it returns from power-loss state. 1 0: System turns off / on when it returns from power-loss state depending on the state before the power loss. 1 1: User defines the resuming state before power loss.(refer to Logic Device A, CRE6[4])
4	R / W	VSBGATE# Enable bit => (Reset by 3VCC) 0: Disable. 1: Enable.
3	R / W	Keyboard wake-up options. 0: Password or sequence hot keys programmed in the registers. 1: Any key.
2	R / W	Enable the hunting mode for all wake-up events set in CRE0. This bit is cleared when any wake-up events is captured. (this bit is reset by LRESET#) (Note. This bit is to generate PSOUT# via KB or MS under S1.) 0: Disable. 1: Enable.
1-0	Reserved.	

**CR E5h. PWROK Option Register**

Location: Address E5h

Attribute: Read/Write

Power Well: VSB

Reset by: RSMRST#

Default : 02h

Size: 8 bits

BIT	READ / WRITE	DESCRIPTION
7-2	Reserved.	
1	R / W	PWROK source selection. 0: PSON#. 1: SLP_S3#.
0	R / W	ATXPGD signal to control PWROK 0: Enable. 1: Disable.

CR E6h.

Location: Address E6h

Attribute: Read/Write

Power Well: VRTC

Reset by: Battery reset

Default : 1Ch

Size: 8 bits

BIT	READ / WRITE	DESCRIPTION
7	R / W	ENMDAT => Three keys (ENMDAT_UP, CRE6[7]; MSRKEY, CRE0[4]; MSXKEY, CRE0[1]) define the combinations of the mouse wake-up events. Please see the table in CRE0, bit 4 for the details.
6	Reserved.	
5	R / W	CASEOPEN Clear Control. Write 1 to this bit to clear CASEOPEN status. This bit will clear the status itself.
4	R / W	Power-loss Last State Flag. 0: ON 1: OFF.
3-1	R / W	PWROK_DEL Set the delay time when rising from 3VCC to PWROK Bits 3 2 1 0 0 0: 300 ~ 600mS 0 0 1: 330 ~ 670mS 0 1 0: 390 ~ 730mS 0 1 1: 520 ~ 860mS 1 0 0: 200 ~ 300mS 1 0 1: 230 ~ 370mS 1 1 0: 290 ~ 430mS 1 1 1: 420 ~ 560mS
0	R / W-Clear	PWROK_TRIG => Write 1 to re-trigger the PWROK signal from low to high.

**CR E7h.**

Location: Address E7h

Attribute: Read/Write

Power Well: VRTC

Reset by: RSMRST#, Battery reset (Bit0, 1, 4)

Default : 00h

Size: 8 bits

BIT	READ / WRITE	DESCRIPTION
7	R / W	ENKD3 => Enable the third set of keyboard wake-up key combination. Its values are accessed through keyboard wake-up index register (CRE1) and keyboard wake-up data register (CRE2) at the index from 40h to 4eh. 0: Disable the third set of the key combinations. 1: Enable the third set of the key combinations.
6	R / W	ENKD2 => Enable the second set of keyboard wake-up key combination. Its values are accessed through keyboard wake-up index register (CRE1) and keyboard wake-up data register (CRE2) at the index from 30h to 3eh. 0: Disable the second set of the key combinations. 1: Enable the second set of the key combinations.
5	R / W	ENWIN98KEY => Enable Win98 keyboard dedicated key to wake-up system via PSOUT# when keyboard wake-up function is enabled. 0: Disable Win98 keyboard wake-up. 1: Enable Win98 keyboard wake-up.
4	R / W	EN_ONPSOUT Disable/Enable to issue a 0.5s delay PSOUT# level when system returns from power loss state and is supposed to be on as described in CRE4[6:5], logic device A. (for SiS & VIA chipsets) 0: Disable. 1: Enable.
3	R / W	Select WDT1 reset source 0: Watchdog timer is reset by LRESET#. 1: Watchdog timer is reset by PWROK.
2	Reserved.	
1	R / W	DIS_RSM2PWR 0: Enable RSMRST# to control PWROK 1: Disable RSMRST# to control PWROK
0	R / W	Hardware Monitor RESET source select 0: PWROK. 1: LRESET#.

**CR F0h.**

Location: Address F0h

Attribute: Read/Write

Power Well: VRTC

Reset by: Battery reset

Default : 80h

Size: 8 bits

BIT	READ / WRITE	DESCRIPTION	
7-6	R / W	Pin64 function selection	
		LDA, CRF0 [Bit7-6]	Pin64
		1x	DEEP_S5_2
		00	3VSBSW
		01	LATCH_BKFD_CUT
5-0	Reserved.		

CR F1h.

Location: Address F1h

Attribute: Read/Write

Power Well: VSB

Reset by: RSMRST#

Default : 00h

Size: 8 bits

BIT	READ / WRITE	DESCRIPTION	
7	R / W-Clear	PME status of the RIA event. Write 1 to clear this status.	
6	R / W-Clear	PME status of the RIB event. Write 1 to clear this status.	
5	R / W-Clear	PME status of the RIC event. Write 1 to clear this status.	
4	R / W-Clear	PME status of the RID event. Write 1 to clear this status.	
3	R / W-Clear	PME status of the RIE event. Write 1 to clear this status.	
2	R / W-Clear	PME status of the RIF event. Write 1 to clear this status.	
1-0	Reserved.		

CR F2h.

Location: Address F2h

Attribute: Read/Write

Power Well: VSB

Reset by: RSMRST#



Default : 40h

Size: 8 bits

BIT	READ / WRITE	DESCRIPTION
7-6	Reserved.	
5	R / W	Block SLP_S3# to PSON# 0: Disable 1: Enable
4-1	Reserved.	
0	R / W	EN_PME => 0 : Disable PME. 1 : Enable PME.

CR F3h.

Location: Address F3h

Attribute: Read/Write

Power Well: VSB

Reset by: RSMRST#

Default : 00h

Size: 8 bits

BIT	READ / WRITE	DESCRIPTION
7-6	Reserved.	
5	R / W-Clear	PME status of the Mouse IRQ event. Write 1 to clear this status.
4	R / W-Clear	PME status of the KBC IRQ event. Write 1 to clear this status.
3	R / W-Clear	PME status of the PRT IRQ event. Write 1 to clear this status.
2	R / W-Clear	PME status of the FDC IRQ event. Write 1 to clear this status.
1	R / W-Clear	PME status of the URA IRQ event. Write 1 to clear this status.
0	R / W-Clear	PME status of the URB IRQ event. Write 1 to clear this status.

CR F4h.

Location: Address F4h

Attribute: Read/Write

Power Well: VSB

Reset by: RSMRST#

Default : 00h

Size: 8 bits

BIT	READ / WRITE	DESCRIPTION
7	R / W-Clear	PME status of the URC IRQ event. Write 1 to clear this status.



BIT	READ / WRITE	DESCRIPTION
6	R / W-Clear	PME status of the URD IRQ event. Write 1 to clear this status.
5	R / W-Clear	PME status of the URE IRQ event. Write 1 to clear this status.
4	R / W-Clear	PME status of the URF IRQ event. Write 1 to clear this status.
3	R / W-Clear	PME status of the HM IRQ event. Write 1 to clear this status.
2	R / W-Clear	PME status of the WDT1 event. Write 1 to clear this status.
1-0	Reserved.	

CR F5h.

Location: Address F5h

Attribute: Read/Write

Power Well: VSB

Reset by: RSMRST#

Default : 00h

Size: 8 bits

BIT	READ / WRITE	DESCRIPTION
7	R / W	0: Disable PME interrupt of the URC IRQ event. 1: Enable PME interrupt of the URC IRQ event.
6	R / W	0: Disable PME interrupt of the URD IRQ event. 1: Enable PME interrupt of the URD IRQ event.
5	R / W	0: Disable PME interrupt of the URE IRQ event. 1: Enable PME interrupt of the URE IRQ event.
4	R / W	0: Disable PME interrupt of the URF IRQ event. 1: Enable PME interrupt of the URF IRQ event.
3-0	Reserved.	

CR F6h.

Location: Address F6h

Attribute: Read/Write

Power Well: VSB

Reset by: RSMRST#

Default : 00h

Size: 8 bits

BIT	READ / WRITE	DESCRIPTION
7	R / W	0: Disable KB, MS interrupt of the KBC password event. 1: Enable KB, MS interrupt of the KBC password event.



BIT	READ / WRITE	DESCRIPTION
6	R / W	0: Disable PME interrupt of the RIA event. 1: Enable PME interrupt of the RIA event.
5	R / W	0: Disable PME interrupt of the Mouse IRQ event. 1: Enable PME interrupt of the Mouse IRQ event.
4	R / W	0: Disable PME interrupt of the KBC IRQ event. 1: Enable PME interrupt of the KBC IRQ event.
3	R / W	0: Disable PME interrupt of the PRT IRQ event. 1: Enable PME interrupt of the PRT IRQ event.
2	R / W	0: Disable PME interrupt of the FDC IRQ event. 1: Enable PME interrupt of the FDC IRQ event.
1	R / W	0: Disable PME interrupt of the URA IRQ event. 1: Enable PME interrupt of the URA IRQ event.
0	R / W	0: Disable PME interrupt of the URB IRQ event. 1: Enable PME interrupt of the URB IRQ event.

CR F7h.

Location: Address F7h

Attribute: Read/Write

Power Well: VSB

Reset by: RSMRST#

Default : 00h

Size: 8 bits

BIT	READ / WRITE	DESCRIPTION
7	R / W	0: Disable PME interrupt of the RIC event. 1: Enable PME interrupt of the RIC event.
6	R / W	0: Disable PME interrupt of the RID event. 1: Enable PME interrupt of the RID event.
5	R / W	0: Disable PME interrupt of the RIE event. 1: Enable PME interrupt of the RIE event.
4	R / W	0: Disable PME interrupt of the CIRWAKEUP IRQ event. 1: Enable PME interrupt of the CIRWAKEUP IRQ event.
3	R / W	0: Disable PME interrupt of the HM IRQ event. 1: Enable PME interrupt of the HM IRQ event.
2	R / W	0: Disable PME interrupt of the WDT1 event. 1: Enable PME interrupt of the WDT1 event.
1	R / W	0: Disable PME interrupt of the RIF event. 1: Enable PME interrupt of the RIF event.
0	R / W	0: Disable PME interrupt of the RIB event. 1: Enable PME interrupt of the RIB event.

**CR F8h.**

Location: Address F8h

Attribute: Read/Write

Power Well: VRTC

Reset by: Battery reset

Default : 00h

Size: 8 bits

BIT	READ / WRITE	DESCRIPTION
7-4	R / W	
3-0	R / W	

CR FAh.

Location: Address FAh

Attribute: Read/Write

Power Well: VSB

Reset by: RSMRST#

Default : 00h

Size: 8 bits

BIT	READ / WRITE	DESCRIPTION
7	R/W	ATXPGD de-bounce for BKFD function. 0: enable 1: disable (de-bounce time depend on LDA_FA[1-0])
6-2	Reserved	
1-0	R/W	ATXPGD de-bounce time select 00: 20us ~ 26us 01: 70us ~ 100us 10: 140us ~ 200us 11: 360us ~ 560us



23.12 Logical Device B (HM, LED)

CR 30h.

Location: Address 30h

Attribute: Read/Write

Power Well: VCC

Reset by: LRESET#

Default : 00h

Size: 8 bits

BIT	READ / WRITE	DESCRIPTION
7-1		Reserved.
0	R / W	0: Hardware Monitor & SB-TSI device is inactive. 1: Hardware Monitor & SB-TSI device is active.

CR 60h, 61h.

Location: Address 60h, 61h

Attribute: Read/Write

Power Well: VCC

Reset by: LRESET#

Default : 00h, 00h

Size: 16 bits

BIT	READ / WRITE	DESCRIPTION
7-0	R / W	These two registers select the HM base address <100h : FFEh> along a two-byte boundary.

CR 62h, 63h.

Location: Address 62h, 63h

Attribute: Read/Write

Power Well: VCC

Reset by: LRESET#

Default : 00h, 00h

Size: 16 bits

BIT	READ / WRITE	DESCRIPTION
7-0	R / W	These two registers select the SB-TSI base address <100h : FFEh> along a two-byte boundary.

CR 70h.

Location: Address 70h

Attribute: Read/Write

Power Well: VCC

Reset by: LRESET#

Default : 00h

Size: 8 bits



BIT	READ / WRITE	DESCRIPTION
7-4	Reserved.	
3-0	R / W	These bits select the IRQ resource for HM.

CR E0h. SYSFAN Duty Cycle Register

Location: Address E0h

Attribute: Read/Write

Power Well: VSB

Reset by: RSMRST#

Default : 7Fh

Size: 8 bits

BIT	READ / WRITE	DESCRIPTION
7-0	R / W	SYSFAN Duty Cycle Register

CR E1h. CPUFAN Duty Cycle Register

Location: Address E1h

Attribute: Read/Write

Power Well: VSB

Reset by: RSMRST#

Default : 7Fh

Size: 8 bits

BIT	READ / WRITE	DESCRIPTION
7-0	R / W	CPUFAN Duty Cycle Register

CR E2h. AUXFAN Duty Cycle Register

Location: Address E2h

Attribute: Read/Write

Power Well: VSB

Reset by: RSMRST#

Default : FFh

Size: 8 bits

BIT	READ / WRITE	DESCRIPTION
7-0	R / W	AUXFAN Duty Cycle Register

CR F0h. FANIN de-bouncer Register

Location: Address F0h

Attribute: Read/Write

Power Well: VSB

Reset by: LRESET#

Default : 00h

Size: 8 bits

BIT	READ / WRITE	DESCRIPTION
-----	--------------	-------------



BIT	READ / WRITE	DESCRIPTION
7	R / W	1: Enable AUXFANIN input de-bouncer. 0: Disable AUXFANIN input de-bouncer.
6	R / W	1: Enable CPUFANIN input de-bouncer. 0: Disable CPUFANIN input de-bouncer.
5	R / W	1: Enable SYSFANIN input de-bouncer. 0: Disable SYSFANIN input de-bouncer.
4-0	Reserved.	

CR F1h. SMI IRQ Register

Location: Address F1h

Attribute: Read/Write

Power Well: VCC

Reset by: LRESET#

Default : 00h

Size: 8 bits

BIT	READ / WRITE	DESCRIPTION
7	R / W	SMI IRQ Enable
6-0	Reserved.	

CR F2h. SMBus de-bouncer Register

Location: Address F2h

Attribute: Read/Write

Power Well: VSB

Reset by: RSMRST#

Default : 00h

Size: 8 bits

BIT	READ / WRITE	DESCRIPTION
7-2	Reserved.	
1	R / W	0: Enable SCL input de-bouncer 80 ~ 120ns. 1: Disable SCL input de-bouncer.
0	R / W	0: Enable SDA input de-bouncer 80 ~ 120ns. 1: Disable SDA input de-bouncer.

CR F3h. DEEPER_SLEEPING_STATE Front panel green & yellow LED control register

Location: Address F3h

Attribute: Read/Write

Power Well: VRTC

Reset by: Battery reset

Default : 00h

Size: 8 bits

BIT	READ / WRITE	DESCRIPTION
7-4	R / W	DEEPS3_YLW_BLK_FREQ bits (powered by VSB, RSMRST# reset, default 000b), when LDB CRF9 Bit 7 is set to 0 1xxx : Fading LED. 0111 : YLW_LED will drive low. 0110 : YLW_LED will output 2Hz , 50% duty-cycle signal. 0101 : YLW_LED will output 1Hz , 50% duty-cycle signal. 0100 : YLW_LED will output 0.5Hz , 50% duty-cycle signal. 0011 : YLW_LED will output 0.25Hz , 50% duty-cycle signal. 0010 : YLW_LED will output 0.125Hz , 50% duty-cycle signal. 0001 : YLW_LED will output 0.0625Hz , 50% duty-cycle signal. 0000 : YLW_LED will output High-Z. (since GRN_LED pin is open-drain).
3-0	R / W	DEEPS3_GRN_BLK_FREQ bits (powered by VSB, RSMRST# reset, default 000b), when LDB CRF9 Bit 6 is set to 0 1xxx : Fading LED. 0111 : GRN_LED will drive low. 0110 : GRN_LED will output 2Hz , 50% duty-cycle signal. 0101 : GRN_LED will output 1Hz , 50% duty-cycle signal. 0100 : GRN_LED will output 0.5Hz , 50% duty-cycle signal. 0011 : GRN_LED will output 0.25Hz , 50% duty-cycle signal. 0010 : GRN_LED will output 0.125Hz , 50% duty-cycle signal. 0001 : GRN_LED will output 0.0625Hz , 50% duty-cycle signal. 0000 : GRN_LED will output High-Z. (since GRN_LED pin is open-drain).

CR F4h. DEEPER_SLEEPING_STATE Front panel green & yellow LED control register

Location: Address F4h

Attribute: Read/Write

Power Well: VRTC

Reset by: Battery reset

Default : 00h

Size: 8 bits

BIT	READ / WRITE	DESCRIPTION
7-4	R / W	DEEPS5_YLW_BLK_FREQ bits (powered by VSB, RSMRST# reset, default 000b), when LDB CRF9 Bit 5 is set to 0 1xxx : Fading LED. 0111 : YLW_LED will drive low. 0110 : YLW_LED will output 2Hz , 50% duty-cycle signal. 0101 : YLW_LED will output 1Hz , 50% duty-cycle signal. 0100 : YLW_LED will output 0.5Hz , 50% duty-cycle signal. 0011 : YLW_LED will output 0.25Hz , 50% duty-cycle signal. 0010 : YLW_LED will output 0.125Hz , 50% duty-cycle signal. 0001 : YLW_LED will output 0.0625Hz , 50% duty-cycle signal. 0000 : YLW_LED will output High-Z. (since GRN_LED pin is open-drain).



BIT	READ / WRITE	DESCRIPTION
3-0	R / W	DEEPS5_GRN_BLK_FREQ bits (powered by VSB, RSMRST# reset, default 000b), when LDB CRF9 Bit 4 is set to 0 1xxx : Fading LED. 0110 : GRN_LED will output 2Hz , 50% duty-cycle signal. 0101 : GRN_LED will output 1Hz , 50% duty-cycle signal. 0100 : GRN_LED will output 0.5Hz , 50% duty-cycle signal. 0011 : GRN_LED will output 0.25Hz , 50% duty-cycle signal. 0010 : GRN_LED will output 0.125Hz , 50% duty-cycle signal. 0001 : GRN_LED will output 0.0625Hz , 50% duty-cycle signal. 0000 : GRN_LED will output High-Z. (since GRN_LED pin is open-drain).

CR F5h. Front panel green LED control register

Location: Address F5h

Attribute: Read/Write

Power Well: VSB

Reset by: RSMRST#

Default : 87h

Size: 8 bits

BIT	READ / WRITE	DESCRIPTION
7	R / W	AUTO_EN bit (powered by VSB, RSMRST# reset , default 1b) Set to 0, the GRN_LED and YLW_LED are controlled by GRN_LED_RST, GRN_BLK_FREQ and YLW_LED_RST, YLW_BLK_FREQ bits. Set to 1, the GRN_LED and YLW_LED are controlled by SLP_S5#, SLP_S3# pins and GRN_BLK_FREQ, YLW_BLK_FREQ bits.
6	R / W	GRN_LED_RST# (powered by VSB, RSMRST# reset , default 0b) Set to 0, GRN_BLK_FREQ will be reset to 000 when (SLP_S3# & internal PWROK) = 0, which means when in S3~S5 states, GRN_LED will output High-Z. Set to 1, GRN_BLK_FREQ will be kept when (SLP_S3# & internal PWROK) = 0.
5	R / W	GRN_LED_POL (powered by VSB, RSMRST# reset , default 0b) Set to 0 , GRN_LED output is active low. Set to 1 , GRN_LED output is active high.
4	Reserved.	
3-0	R / W	GRN_BLK_FREQ bits (powered by VSB, RSMRST# reset, default 000b) 1xxx : Fading LED. 0111 : GRN_LED will drive low. 0110 : GRN_LED will output 2Hz , 50% duty-cycle signal. 0101 : GRN_LED will output 1Hz , 50% duty-cycle signal. 0100 : GRN_LED will output 0.5Hz , 50% duty-cycle signal. 0011 : GRN_LED will output 0.25Hz , 50% duty-cycle signal. 0010 : GRN_LED will output 0.125Hz , 50% duty-cycle signal. 0001 : GRN_LED will output 0.0625Hz , 50% duty-cycle signal. 0000 : GRN_LED will output High-Z. (since GRN_LED pin is open-drain).

CR F6h. Front panel yellow LED control register

Location: Address F6h



Attribute: Read/Write

Power Well: VSB

Reset by: RSMRST#

Default : 47h

Size: 8 bits

BIT	READ / WRITE	DESCRIPTION
7	Reserved.	
6	R / W	YLV_LED_RST# (powered by VSB, RSMRST# reset , default 1b) Set to 0, YLV_BLK_FREQ will be reset to 000 when (SLP_S3# & internal PWROK) = 0, which means when in S3~S5 states, YLV_LED will output High-Z. Set to 1, YLV_BLK_FREQ will be kept when (SLP_S3# & internal PWROK) = 0.
5	R / W	YLV_LED_POL (powered by VSB, RSMRST# reset , default 0b) Set to 0, YLV_LED output is active low. Set to 1, YLV_LED output is active high.
4	Reserved.	
3-0	R / W	YLV_BLK_FREQ bits (powered by VSB, RSMRST# reset, default 111b) 1xxx : Fading LED. 0111 : YLV_LED will drive low. 0110 : YLV_LED will output 2Hz , 50% duty-cycle signal. 0101 : YLV_LED will output 1Hz , 50% duty-cycle signal. 0100 : YLV_LED will output 0.5Hz , 50% duty-cycle signal. 0011 : YLV_LED will output 0.25Hz , 50% duty-cycle signal. 0010 : YLV_LED will output 0.125Hz , 50% duty-cycle signal. 0001 : YLV_LED will output 0.0625Hz , 50% duty-cycle signal. 0000 : YLV_LED will output High-Z. (since YLV_LED pin is open-drain).

CR F7h.YLV & GRN Eanble register

Location: Address F7h

Attribute: Read/Write

Power Well: VRTC

Reset by: Battery reset

Default : 00h

Size: 8 bits

BIT	READ / WRITE	DESCRIPTION
7	R / W	YLV_DEEPS3_SET
6	R / W	GRN_DEEPS3_SET
5	R / W	YLV_DEEPS5_SET
4	R / W	GRN_DEEPS5_SET
3-0	Reserved.	



23.13 Logical Device D (WDT2)

CR E0h. Watchdog Timer II(WDTII) Control Register

Location: Address E0h

Attribute: Read/Write

Power Well: VSB

Reset by: RSMRST#

Default : 00h

Size: 8 bits

BIT	READ / WRITE	DESCRIPTION
7-4	Reserved.	
3-2	R / W	Clock select of 5 second Watchdog Timer II Bits 3 2 = 0 0, clock rate 4Hz = 0 1, clock rate 1Hz = 1 0, cloak rate 1/2Hz = 1 1, clock rate 1MHz
1-0	R / W	Clock select of 100ms Watchdog Timer II Bits 1 0 = 0 0, clock rate 512Hz, WDT will generate 100mS low pulse after 5S = 0 1, clock rate 256Hz, WDT will generate 200mS low pulse after 5S = 1 0, clock rate 1KHz, WDT will generate 50mS low pulse after 5S = 1 1, clock rate 1MHz, WDT will generate 50uS low pulse after 5S

CR E1h. Watchdog Timer II 100ms counter Register

Location: Address E1h

Attribute: Read only

Power Well: VSB

Reset by: RSMRST#

Default : 32h

Size: 8 bits

BIT	READ / WRITE	DESCRIPTION
7-0	R	Setting of 100mS watch dog time out counter. Default is 8'h32. Note. If CRE7[1:0] is 2'b00, then Watchdog Timer II 100ms counter will be 1.95ms(512Hz) * 50(8'h32) = 100m sec

CR E2h. Watchdog Timer II 5s counter Register

Location: Address E2h

Attribute: Read only

Power Well: VSB

Reset by: RSMRST#

Default : 14h



Size: 8 bits

BIT	READ / WRITE	DESCRIPTION
7-0	R	Setting of 5 second watch dog time out counter. Default is 8'h14. Note. If CRE7[3:2] is 2'b00, then Watchdog Timer II counter will be $0.25s(4Hz) * 20(8'h14) = 5 \text{ sec}$

CR E3h. Watchdog Timer II Software Reset Register

Location: Address E3h

Attribute: Read/Write

Power Well: VSB

Reset by: RSMRST#

Default : 00h

Size: 8 bits

BIT	READ / WRITE	DESCRIPTION
7-1	Reserved.	
0	R/W	This bit is used to start Watchdog Timer II counter 0: Disable 1: Start the counter. When the time is up, it will clear itself to 0.

CR E4h. Watchdog Timer II Status Register

Location: Address E4h

Attribute: Read/Write

Power Well: VSB

Reset by: RSMRST#

Default : 00h

Size: 8 bits

BIT	READ / WRITE	DESCRIPTION
7	R/W	Watchdog Timer II status. When this bit is set to 1, it means timeout event occurs.
6-0	Reversed	



23.14 Logical Device E (CIR WAKE-UP)

CR 30h.

Location: Address 00h

Attribute: Read/Write

Power Well: VCC

Reset by: LRESET#

Default : 00h

Size: 8 bits

BIT	READ / WRITE	DESCRIPTION
7-1		Reserved.
0	R / W	0: CIR Wake-up is inactive. 1: CIR Wake-up Interface is active.

CR 60h, 61h.

Location: Address 60h, 61h

Attribute: Read/Write

Power Well: VCC

Reset by: LRESET#

Default : 00h, 00h

Size: 16 bits

BIT	READ / WRITE	DESCRIPTION
7-0	R / W	These two registers select CIR Wake-up Interface I/O base address <100h: FF8h> on 1 byte boundary.

CR 70h.

Location: Address 70h

Attribute: Read/Write

Power Well: VCC

Reset by: LRESET#

Default : 00h

Size: 8 bits

BIT	READ / WRITE	DESCRIPTION
7-4		Reserved.
3-0	R / W	These bits select IRQ resource for CIR Wake-up.

CR E0h.

Location: Address E0h

Attribute: Read/Write

Power Well: VRTC

Reset by: Battery reset

Default : 25h



Size: 8 bits

BIT	READ / WRITE	DESCRIPTION
7-6	Reserved.	
5-0	R / W	Clock 1M to 40K divisor register

CR E1h.

Location: Address E1h

Attribute: Read/Write

Power Well: VSB

Reset by: LRESET#

Default : 00h

Size: 8 bits

BIT	READ / WRITE	DESCRIPTION
7-6	Reserved.	
2	R/W	Clock 1M to 40K divisor number flush. Write 1 then auto-clear.
1	R/W1C	CIR Wake-up clock calibration done status bit. .
0	R/W	CIR Wake-up clock calibration enable. Cleaned once calibration is done.



23.15 Logical Device F (GPIO)

CR E0h.

Location: Address E0h

Attribute: Read/Write

Power Well: VSB

Reset by: RSMRST#

Default : FFh

Size: 8 bits

BIT	READ / WRITE	DESCRIPTION
7-0	R / W	GP0 Push-Pull/OD select 0:Push-Pull 1:Open Drain

CR E1h.

Location: Address E1h

Attribute: Read/Write

Power Well: VSB

Reset by: RSMRST#

Default : FFh

Size: 8 bits

BIT	READ / WRITE	DESCRIPTION
7-0	R / W	GP1 Push-Pull/OD select 0:Push-Pull 1:Open Drain

CR E2h.

Location: Address E2h

Attribute: Read/Write

Power Well: VSB

Reset by: RSMRST#

Default : FFh

Size: 8 bits

BIT	READ / WRITE	DESCRIPTION
7-0	R / W	GP2 Push-Pull/OD select 0:Push-Pull 1:Open Drain

CR E3h.

Location: Address E3h

Attribute: Read/Write

Power Well: VSB

Reset by: RSMRST#



Default : FFh

Size: 8 bits

BIT	READ / WRITE	DESCRIPTION
7-0	R / W	GP3 Push-Pull/OD select 0:Push-Pull 1:Open Drain

CR E4h.

Location: Address E4h

Attribute: Read/Write

Power Well: VSB

Reset by: RSMRST#

Default : FFh

Size: 8 bits

BIT	READ / WRITE	DESCRIPTION
7-0	R / W	GP4 Push-Pull/OD select 0:Push-Pull 1:Open Drain

CR E5h.

Location: Address E5h

Attribute: Read/Write

Power Well: VSB

Reset by: RSMRST#

Default : FFh

Size: 8 bits

BIT	READ / WRITE	DESCRIPTION
7-0	R / W	GP5 Push-Pull/OD select 0:Push-Pull 1:Open Drain

CR E6h.

Location: Address E6h

Attribute: Read/Write

Power Well: VSB

Reset by: RSMRST#

Default : FFh

Size: 8 bits

BIT	READ / WRITE	DESCRIPTION
7-0	R / W	GP6 Push-Pull/OD select 0:Push-Pull 1:Open Drain

**CR E7h.**

Location: Address E7h

Attribute: Read/Write

Power Well: VSB

Reset by: RSMRST#

Default : 03h

Size: 8 bits

BIT	READ / WRITE	DESCRIPTION
7-2		Reserved.
1	R / W	GP7 Push-Pull/OD select 0:Push-Pull 1:Open Drain
0		Reserved.

CR F0h. I2C Control & Address Register

Location: Address F0h

Attribute: Read/Write

Power Well: VSB

Reset by: RSMRST#

Default : 9Dh

Size: 8 bits

BIT	READ / WRITE	DESCRIPTION
7	R / W	Enable I2C_Slave
6-0	R / W	I2C Address

CR F1h. I2C to 80PORT Control Register

Location: Address F1h

Attribute: Read/Write

Power Well: VSB

Reset by: LRESET#

Default : 00h

Size: 8 bits

BIT	READ / WRITE	DESCRIPTION
7-2		Reserved.
1	R / W	80PORT Display 0: Enable 1: Disable
0	R / W	LPC or I2C to 80PORT switch 0: LPC 1: I2C

CR F2h. I2C to 80PORT Data Register

Location: Address F2h



Attribute: Read/Write

Power Well: VSB

Reset by: RSMRST#

Default : 00h

Size: 8 bits

BIT	READ / WRITE	DESCRIPTION
7-0	R / W	I2C to 80PORT Data



23.16 Logical Device 10 (UARTC)

CR 30h.

Location: Address 30h

Attribute: Read/Write

Power Well: VCC

Reset by: LRESET#

Default : 00h

Size: 8 bits

BIT	READ / WRITE	DESCRIPTION
7-1		Reserved.
0	R / W	0: The logical device is inactive. 1: The logical device is active.

CR 60h, 61h.

Location: Address 60h, 61h

Attribute: Read/Write

Power Well: VCC

Reset by: LRESET#

Default : 03h, E0h

Size: 16 bits

BIT	READ / WRITE	DESCRIPTION
7-0	R / W	These two registers select IR I/O base address <100h: FF8h> on eight-byte boundary.

CR 70h.

Location: Address 70h

Attribute: Read/Write

Power Well: VCC

Reset by: LRESET#

Default : 04h

Size: 8 bits

BIT	READ / WRITE	DESCRIPTION
7-4		Reserved.
3-0	R / W	These bits select IRQ resource for Serial Port 3.

CR F0h.

Location: Address F0h

Attribute: Read/Write

Power Well: VCC

Reset by: LRESET#

Default : 00h

Size: 8 bits



BIT	READ / WRITE	DESCRIPTION
7	R / W	0: Delay RXCLK for 5 ns for LG issue. 1: No delay of 5 ns for RXCLK.
6	R / W	0: IRQ is the level mode. 1: IRQ is the pulse mode for IRQ sharing function.
5	R / W	0: Using the original RX FIFO Error Indication signal (USR bit 7). 1: Using new RX FIFO Error Indication signal to solve some issues.
4-2	Reserved.	
1-0	R / W	Bits 1 0 0 0: UART C clock source is 1.8462 MHz (24 MHz / 13). 0 1: UART C clock source is 2 MHz (24 MHz / 12). 0 0: UART C clock source is 24 MHz (24 MHz / 1). 0 0: UART C clock source is 14.769 MHz (24 MHz / 1.625).

CR F2h. UARTC 9bit-mode Config Register

Location: Address F2h

Attribute: Read/Write

Power Well: VCC

Reset by: LRESET#

Default : 00h

Size: 8 bits

BIT	READ / WRITE	DESCRIPTION
7	R / W	En_auto_RX_ctrl 0: 9bitmode RX block function will pass all data or address byte and not compare any address byte. 1: 9bitmode RX block function could only receive address byte and compare the address bytes. (The address matched or not will issue IRQ. Refer to CRF6 description)
6	R / W	En_auto_only_addr_comp 0: When setting en_auto_RX_ctrl =1'b1, 9bitmode RX block function will compare the address byte and update the RX_ctrl Bit automatically. 1: When setting en_auto_RX_ctrl =1'b1, 9bitmode RX block function will only compare the address byte. But the RX_ctrl Bit will not be updated automatically by 9bitmode RX block function.
5	R / W	RST_low_time_sel 0: TX block will keep 1 bit time before inverting the driving signal. 1: TX block will keep 2 bit time before inverting the driving signal.
4	R / W	RS485_RTS_inv_sel 0: Automatic drive RTS# low when receiving data. Automatic drive RTS# high when transmitting data. 1: Automatic drive RTS# high when receiving data. Automatic drive RTS# low when transmitting data.



BIT	READ / WRITE	DESCRIPTION
3	R / W	En_auto_TX_ctrl 0: En_address_byte bit will not be automatic updated to "logic 0" by hardware after TX block sent address byte. 1: En_address_byte bit will be automatic updated to "logic 0" by hardware after TX block sent address byte.
2	R / W	En_auto_RX_ctrl 0: the address byte will be ingored by the receiver. 1: the address byte will be received into RX FIFO by the receiver.
1	R / W	En_RS485_RTS 0: RS232 driver 1: RS485 driver The 9bitmode TX block function will drive RTS_L to high when transmit data automatically
0	R / W	En_9bit_mode 0: normal UART function. 1: enable 9-bit mode function. (9bit-TX block use parity bit as address/Data bit when setting En_9bit_mode = 1'b1.)

CR F3h. UARTC 9bit-mode Slave Address Register

Location: Address F3h

Attribute: Read/Write

Power Well: VCC

Reset by: LRESET#

Default : 00h

Size: 8 bits

BIT	READ / WRITE	DESCRIPTION
7-0	R / W	Slave address

CR F4h. UARTC 9bit-mode Slave Mask Address Register

Location: Address F4h

Attribute: Read/Write

Power Well: VCC

Reset by: LRESET#

Default : FFh

Size: 8 bits

BIT	READ / WRITE	DESCRIPTION
7-0	R / W	Slave mask address

CR F5h. UARTC 9bit-mode Broadcase Address Register

Location: Address F5h

Attribute: Read/Write



Power Well: VCC

Reset by: LRESET#

Default : FFh

Size: 8 bits

BIT	READ / WRITE	DESCRIPTION
7-0	R / W	Broadcast Address

CR F6h. UARTC 9bit-mode Interrupt Control Register

Location: Address F6h

Attribute: Read/Write

Power Well: VCC

Reset by: LRESET#

Default : 02h

Size: 8 bits

BIT	READ / WRITE	DESCRIPTION
7-2	Reserved.	
1	R / W	IRQ_type_sel 0: 9bitmode RX block function will issue an IRQ when receive any address byte. (when IRQ_addr_Enable bit = 1) 1: 9bitmode RX block function will issue an IRQ when only receive the matched address byte. (when IRQ_addr_Enable bit = 1)
0	R / W	IRQ_addr_Enable 0: Disable UARTC 9bit-mode IRQ output. 1: Enable UARTC 9bit-mode IRQ output.

CR F7h. UARTC 9bit-mode IRQ Status Register

Location: Address F7h

Attribute: Read/Write

Power Well: VCC

Reset by: LRESET#

Default : 00h

Size: 8 bits

BIT	READ / WRITE	DESCRIPTION
7-1	Reserved.	
0	R / W	UARTC 9bit-mode Status Bit 0: UARTC 9bit-mode IRQ have not been triggered. 1: UARTC 9bit-mode IRQ have been triggered.

CR F8h. Extending UARTC Control Register

Location: Address F8h

Attribute: Read/Write

Power Well: VCC



Reset by: LRESET#

Default : 00h

Size: 8 bits

BIT	7	6	5	4	3	2	1	0
NAME	fifo_level_mode		Reserved	uartCD_switch_enable	Reserved <i>(All should be set to 0)</i>			Enable_128_bytes_fifo
DEFAULT	0	0	0	0	0	0	0	0

BIT	DESCRIPTION																																									
7-6	fifo_level_mode: (Also check UFR register B7-6 definition)																																									
	<table border="1"> <thead> <tr> <th colspan="2"></th> <th colspan="4">RX FIFO INTERRUPT ACTIVE LEVEL (BYTES)</th> </tr> <tr> <th>UFR_BIT 7</th> <th>UFR_BIT 6</th> <th>FIFO_LEVEL_MODE (CRF8_B7:6 = 00)</th> <th>FIFO_LEVEL_MODE (CRF8_B7:6 = 01)</th> <th>FIFO_LEVEL_MODE (CRF8_B7:6 = 10)</th> <th>FIFO_LEVEL_MODE (CRF8_B7:6 = 11)</th> </tr> </thead> <tbody> <tr> <td>0</td> <td>0</td> <td>01</td> <td>16</td> <td>80</td> <td>112</td> </tr> <tr> <td>0</td> <td>1</td> <td>04</td> <td>32</td> <td>88</td> <td>116</td> </tr> <tr> <td>1</td> <td>0</td> <td>08</td> <td>48</td> <td>96</td> <td>120</td> </tr> <tr> <td>1</td> <td>1</td> <td>14</td> <td>64</td> <td>104</td> <td>124</td> </tr> </tbody> </table>								RX FIFO INTERRUPT ACTIVE LEVEL (BYTES)				UFR_BIT 7	UFR_BIT 6	FIFO_LEVEL_MODE (CRF8_B7:6 = 00)	FIFO_LEVEL_MODE (CRF8_B7:6 = 01)	FIFO_LEVEL_MODE (CRF8_B7:6 = 10)	FIFO_LEVEL_MODE (CRF8_B7:6 = 11)	0	0	01	16	80	112	0	1	04	32	88	116	1	0	08	48	96	120	1	1	14	64	104	124
		RX FIFO INTERRUPT ACTIVE LEVEL (BYTES)																																								
UFR_BIT 7	UFR_BIT 6	FIFO_LEVEL_MODE (CRF8_B7:6 = 00)	FIFO_LEVEL_MODE (CRF8_B7:6 = 01)	FIFO_LEVEL_MODE (CRF8_B7:6 = 10)	FIFO_LEVEL_MODE (CRF8_B7:6 = 11)																																					
0	0	01	16	80	112																																					
0	1	04	32	88	116																																					
1	0	08	48	96	120																																					
1	1	14	64	104	124																																					
5	Reserved.																																									
4	uartCD_switch_enable (Bypass mode) 0: switch disable 1: switch enable																																									
3-1	Reserved. <i>(All should be set to 0)</i>																																									
0	Extending fifo enable bit: 0: Disable128bytes TX and RX FIFO. 1: Enable128bytes TX and RX FIFO.																																									



23.17 Logical Device 11 (UARTD)

CR 30h.

Location: Address 30h

Attribute: Read/Write

Power Well: VCC

Reset by: LRESET#

Default : 00h

Size: 8 bits

BIT	READ / WRITE	DESCRIPTION
7-1		Reserved.
0	R / W	0: The logical device is inactive. 1: The logical device is active.

CR 60h, 61h.

Location: Address 60h, 61h

Attribute: Read/Write

Power Well: VCC

Reset by: LRESET#

Default : 02h, E0h

Size: 16 bits

BIT	READ / WRITE	DESCRIPTION
7-0	R / W	These two registers select IR I/O base address <100h: FF8h> on eight-byte boundary.

CR 70h.

Location: Address 70h

Attribute: Read/Write

Power Well: VCC

Reset by: LRESET#

Default : 03h

Size: 8 bits

BIT	READ / WRITE	DESCRIPTION
7-4		Reserved.
3-0	R / W	These bits select IRQ resource for Serial Port 4.

CR F0h.

Location: Address F0h

Attribute: Read/Write

Power Well: VCC

Reset by: LRESET#

Default : 00h

Size: 8 bits



BIT	READ / WRITE	DESCRIPTION
7	R / W	0: Delay RXCLK for 5 ns for LG issue. 1: No delay of 5 ns for RXCLK.
6	R / W	0: IRQ is the level mode. 1: IRQ is the pulse mode for IRQ sharing function.
5	R / W	0: Using the original RX FIFO Error Indication signal (USR bit 7). 1: Using new RX FIFO Error Indication signal to solve some issues.
4-2	Reserved.	
1-0	R / W	Bits 1 0 0 0: UART D clock source is 1.8462 MHz (24 MHz / 13). 0 1: UART D clock source is 2 MHz (24 MHz / 12). 0 0: UART D clock source is 24 MHz (24 MHz / 1). 0 0: UART D clock source is 14.769 MHz (24 MHz / 1.625).

CR F2h. UARTD 9bit-mode Config Register

Location: Address F1h

Attribute: Read/Write

Power Well: VCC

Reset by: LRESET#

Default : 00h

Size: 8 bits

BIT	READ / WRITE	DESCRIPTION
7	R / W	En_auto_RX_ctrl 0: 9bitmode RX block function will pass all data or address byte and not compare any address byte. 1: 9bitmode RX block function could only receive address byte and compare the address bytes. (The address matched or not will issue IRQ. Refer to CRF6 description)
6	R / W	En_auto_only_addr_comp 0: When setting en_auto_RX_ctrl =1'b1, 9bitmode RX block function will compare the address byte and update the RX_ctrl Bit automatically. 1: When setting en_auto_RX_ctrl =1'b1, 9bitmode RX block function will only compare the address byte. But the RX_ctrl Bit will not be updated automatically by 9bitmode RX block function.
5	R / W	RST_low_time_sel 0: TX block will keep 1 bit time before inverting the driving signal. 1: TX block will keep 2 bit time before inverting the driving signal.
4	R / W	RS485_RTS_inv_sel 0: Automatic drive RTS# low when receiving data. Automatic drive RTS# high when transmitting data. 1: Automatic drive RTS# high when receiving data. Automatic drive RTS# low when transmitting data.

BIT	READ / WRITE	DESCRIPTION
3	R / W	En_auto_TX_ctrl 0: En_address_byte bit will not be automatic updated to "logic 0" by hardware after TX block sent address byte. 1: En_address_byte bit will be automatic updated to "logic 0" by hardware after TX block sent address byte.
2	R / W	En_auto_RX_ctrl 0: the address byte will be ingored by the receiver. 1: the address byte will be received into RX FIFO by the receiver.
1	R / W	En_RS485_RTS 0: RS232 driver 1: RS485 driver The 9bitmode TX block function will drive RTS_L to high when transmit data automatically
0	R / W	En_9bit_mode 0: normal UART function. 1: enable 9-bit mode function. (9bit-TX block use parity bit as address/Data bit when setting En_9bit_mode = 1'b1.)

CR F3h. UARTD 9bit-mode Slave Address Register

Location: Address F2h

Attribute: Read/Write

Power Well: VCC

Reset by: LRESET#

Default : 00h

Size: 8 bits

BIT	READ / WRITE	DESCRIPTION
7-0	R / W	Slave address

CR F4h. UARTD 9bit-mode Slave Mask Address Register

Location: Address F3h

Attribute: Read/Write

Power Well: VCC

Reset by: LRESET#

Default : FFh

Size: 8 bits

BIT	READ / WRITE	DESCRIPTION
7-0	R / W	Slave mask address

CR F5h. UARTD 9bit-mode Broadcase Address Register

Location: Address F4h

Attribute: Read/Write



Power Well: VCC

Reset by: LRESET#

Default : FFh

Size: 8 bits

BIT	READ / WRITE	DESCRIPTION
7-0	R / W	Broadcase Address

CR F6h. UARTD 9bit-mode Interrupt Control Register

Location: Address F5h

Attribute: Read/Write

Power Well: VCC

Reset by: LRESET#

Default : 02h

Size: 8 bits

BIT	READ / WRITE	DESCRIPTION
7-2	Reserved.	
1	R / W	IRQ_type_sel 0: 9bitemode RX block function will issue an IRQ when receive any address byte. (when IRQ_addr_Enable bit = 1) 1: 9bitemode RX block function will issue an IRQ when only receive the matched address byte. (when IRQ_addr_Enable bit = 1)
0	R / W	IRQ_addr_Enable 0: Disable UARTD 9bit-mode IRQ output. 1: Enalbe UARTD 9bit-mode IRQ output.

CR F7h. UARTD 9bit-mode IRQ Status Register

Location: Address F6h

Attribute: Read/Write

Power Well: VCC

Reset by: LRESET#

Default : 00h

Size: 8 bits

BIT	READ / WRITE	DESCRIPTION
7-1	Reserved.	
0	R / W	UARTD 9bit-mode Status Bit 0: UARTD 9bit-mode IRQ have not been triggered. 1: UARTD 9bit-mode IRQ have been triggered.

CR F8h. Extending UARTD Control Register

Location: Address F7h

Attribute: Read/Write

Power Well: VCC



Reset by: LRESET#

Default : 00h

Size: 8 bits

BIT	7	6	5	4	3	2	1	0
NAME	fifo_level_mode		Reserved		Reserved (All should be set to 0)			Enable_128_bytes_fifo
DEFAULT	0	0	0	0	0	0	0	0

BIT	DESCRIPTION					
7-6	fifo_level_mode: (Also check UFR register B7-6 definition)					
	UFR_ BIT 7	UFR_ BIT 6	RX FIFO INTERRUPT ACTIVE LEVEL (BYTES)			
			FIFO_LEVEL_ MODE (CRF8_B7:6 = 00)	FIFO_LEVEL_ MODE (CRF8_B7:6 = 01)	FIFO_LEVEL_ MODE (CRF8_B7:6 = 10)	FIFO_LEVEL_ MODE (CRF8_B7:6 = 11)
	0	0	01	16	80	112
	0	1	04	32	88	116
	1	0	08	48	96	120
	1	1	14	64	104	124
5-4	Reserved.					
3-1	Reserved. (All should be set to 0)					
0	Extending fifo enable bit: 0: Disable 128bytes TX and RX FIFO. 1: Enable 128bytes TX and RX FIFO.					



23.18 Logical Device 12 (UARTE)

CR 30h.

Location: Address 30h

Attribute: Read/Write

Power Well: VCC

Reset by: LRESET#

Default : 00h

Size: 8 bits

BIT	READ / WRITE	DESCRIPTION
7-1		Reserved.
0	R / W	0: The logical device is inactive. 1: The logical device is active.

CR 60h, 61h.

Location: Address 60h, 61h

Attribute: Read/Write

Power Well: VCC

Reset by: LRESET#

Default : 03h, E8h

Size: 16 bits

BIT	READ / WRITE	DESCRIPTION
7-0	R / W	These two registers select IR I/O base address <100h: FF8h> on eight-byte boundary.

CR 70h.

Location: Address 70h

Attribute: Read/Write

Power Well: VCC

Reset by: LRESET#

Default : 04h

Size: 8 bits

BIT	READ / WRITE	DESCRIPTION
7-4		Reserved.
3-0	R / W	These bits select IRQ resource for Serial Port 5.

CR F0h.

Location: Address F0h

Attribute: Read/Write

Power Well: VCC

Reset by: LRESET#

Default : 00h

Size: 8 bits



BIT	READ / WRITE	DESCRIPTION
7	R / W	0: Delay RXCLK for 5 ns for LG issue. 1: No delay of 5 ns for RXCLK.
6	R / W	0: IRQ is the level mode. 1: IRQ is the pulse mode for IRQ sharing function.
5	R / W	0: Using the original RX FIFO Error Indication signal (USR bit 7). 1: Using new RX FIFO Error Indication signal to solve some issues.
4-2	Reserved.	
1-0	R / W	Bits 1 0 0 0: UART E clock source is 1.8462 MHz (24 MHz / 13). 0 1: UART E clock source is 2 MHz (24 MHz / 12). 0 0: UART E clock source is 24 MHz (24 MHz / 1). 0 0: UART E clock source is 14.769 MHz (24 MHz / 1.625).

CR F2h. UARTE 9bit-mode Config Register

Location: Address F1h

Attribute: Read/Write

Power Well: VCC

Reset by: LRESET#

Default : 00h

Size: 8 bits

BIT	READ / WRITE	DESCRIPTION
7	R / W	En_auto_RX_ctrl 0: 9bitmode RX block function will pass all data or address byte and not compare any address byte. 1: 9bitmode RX block function could only receive address byte and compare the address bytes. (The address matched or not will issue IRQ. Refer to CRF6 description)
6	R / W	En_auto_only_addr_comp 0: When setting en_auto_RX_ctrl =1'b1, 9bitmode RX block function will compare the address byte and update the RX_ctrl Bit automatically. 1: When setting en_auto_RX_ctrl =1'b1, 9bitmode RX block function will only compare the address byte. But the RX_ctrl Bit will not be updated automatically by 9bitmode RX block function.
5	R / W	RST_low_time_sel 0: TX block will keep 1 bit time before inverting the driving signal. 1: TX block will keep 2 bit time before inverting the driving signal.
4	R / W	RS485_RTS_inv_sel 0: Automatic drive RTS# low when receiving data. Automatic drive RTS# high when transmitting data. 1: Automatic drive RTS# high when receiving data. Automatic drive RTS# low when transmitting data.



BIT	READ / WRITE	DESCRIPTION
3	R / W	En_auto_TX_ctrl 0: En_address_byte bit will not be automatic updated to "logic 0" by hardware after TX block sent address byte. 1: En_address_byte bit will be automatic updated to "logic 0" by hardware after TX block sent address byte.
2	R / W	En_auto_RX_ctrl 0: the address byte will be ingored by the receiver. 1: the address byte will be received into RX FIFO by the receiver.
1	R / W	En_RS485_RTS 0: RS232 driver 1: RS485 driver The 9bitmode TX block function will drive RTS_L to high when transmit data automatically
0	R / W	En_9bit_mode 0: normal UART function. 1: enable 9-bit mode function. (9bit-TX block use parity bit as address/Data bit when setting En_9bit_mode = 1'b1.)

CR F3h. UARTE 9bit-mode Slave Address Register

Location: Address F2h

Attribute: Read/Write

Power Well: VCC

Reset by: LRESET#

Default : 00h

Size: 8 bits

BIT	READ / WRITE	DESCRIPTION
7-0	R / W	Slave address

CR F4h. UARTE 9bit-mode Slave Mask Address Register

Location: Address F3h

Attribute: Read/Write

Power Well: VCC

Reset by: LRESET#

Default : FFh

Size: 8 bits

BIT	READ / WRITE	DESCRIPTION
7-0	R / W	Slave mask address

CR F5h. UARTE 9bit-mode Broadcase Address Register

Location: Address F4h

Attribute: Read/Write



Power Well: VCC

Reset by: LRESET#

Default : FFh

Size: 8 bits

BIT	READ / WRITE	DESCRIPTION
7-0	R / W	Broadcast Address

CR F6h. UARTE 9bit-mode Interrupt Control Register

Location: Address F5h

Attribute: Read/Write

Power Well: VCC

Reset by: LRESET#

Default : 02h

Size: 8 bits

BIT	READ / WRITE	DESCRIPTION
7-2	Reserved.	
1	R / W	IRQ_type_sel 0: 9bitmode RX block function will issue an IRQ when receive any address byte. (when IRQ_addr_Enable bit = 1) 1: 9bitmode RX block function will issue an IRQ when only receive the matched address byte. (when IRQ_addr_Enable bit = 1)
0	R / W	IRQ_addr_Enable 0: Disable UARTE 9bit-mode IRQ output. 1: Enable UARTE 9bit-mode IRQ output.

CR F7h. UARTE 9bit-mode IRQ Status Register

Location: Address F6h

Attribute: Read/Write

Power Well: VCC

Reset by: LRESET#

Default : 00h

Size: 8 bits

BIT	READ / WRITE	DESCRIPTION
7-1	Reserved.	
0	R / W	UARTE 9bit-mode Status Bit 0: UARTE 9bit-mode IRQ have not been triggered. 1: UARTE 9bit-mode IRQ have been triggered.

CR F8h. Extending UARTE Control Register

Location: Address F7h

Attribute: Read/Write

Power Well: VCC



Reset by: LRESET#

Default : 00h

Size: 8 bits

BIT	7	6	5	4	3	2	1	0
NAME	fifo_level_mode		Reserved	uartEF_switch_enable	Reserved <i>(All should be set to 0)</i>			Enable_128_bytes_fifo
DEFAULT	0	0	0	0	0	0	0	0

BIT	DESCRIPTION																																									
7-6	fifo_level_mode: (Also check UFR register B7-6 definition)																																									
	<table border="1"> <thead> <tr> <th colspan="2"></th> <th colspan="4">RX FIFO INTERRUPT ACTIVE LEVEL (BYTES)</th> </tr> <tr> <th>UFR_BIT 7</th> <th>UFR_BIT 6</th> <th>FIFO_LEVEL_MODE (CRF8_B7:6 = 00)</th> <th>FIFO_LEVEL_MODE (CRF8_B7:6 = 01)</th> <th>FIFO_LEVEL_MODE (CRF8_B7:6 = 10)</th> <th>FIFO_LEVEL_MODE (CRF8_B7:6 = 11)</th> </tr> </thead> <tbody> <tr> <td>0</td> <td>0</td> <td>01</td> <td>16</td> <td>80</td> <td>112</td> </tr> <tr> <td>0</td> <td>1</td> <td>04</td> <td>32</td> <td>88</td> <td>116</td> </tr> <tr> <td>1</td> <td>0</td> <td>08</td> <td>48</td> <td>96</td> <td>120</td> </tr> <tr> <td>1</td> <td>1</td> <td>14</td> <td>64</td> <td>104</td> <td>124</td> </tr> </tbody> </table>								RX FIFO INTERRUPT ACTIVE LEVEL (BYTES)				UFR_BIT 7	UFR_BIT 6	FIFO_LEVEL_MODE (CRF8_B7:6 = 00)	FIFO_LEVEL_MODE (CRF8_B7:6 = 01)	FIFO_LEVEL_MODE (CRF8_B7:6 = 10)	FIFO_LEVEL_MODE (CRF8_B7:6 = 11)	0	0	01	16	80	112	0	1	04	32	88	116	1	0	08	48	96	120	1	1	14	64	104	124
		RX FIFO INTERRUPT ACTIVE LEVEL (BYTES)																																								
UFR_BIT 7	UFR_BIT 6	FIFO_LEVEL_MODE (CRF8_B7:6 = 00)	FIFO_LEVEL_MODE (CRF8_B7:6 = 01)	FIFO_LEVEL_MODE (CRF8_B7:6 = 10)	FIFO_LEVEL_MODE (CRF8_B7:6 = 11)																																					
0	0	01	16	80	112																																					
0	1	04	32	88	116																																					
1	0	08	48	96	120																																					
1	1	14	64	104	124																																					
5	Reserved.																																									
4	uartEF_switch_enable (Bypass mode) 0: switch disable 1: switch enable																																									
3-1	Reserved. <i>(All should be set to 0)</i>																																									
0	Extending fifo enable bit: 0: Disable128bytes TX and RX FIFO. 1: Enable128bytes TX and RX FIFO.																																									



23.19 Logical Device 13 (UARTF)

CR 30h.

Location: Address 30h

Attribute: Read/Write

Power Well: VCC

Reset by: LRESET#

Default : 00h

Size: 8 bits

BIT	READ / WRITE	DESCRIPTION
7~1		Reserved.
0	R / W	0: The logical device is inactive. 1: The logical device is active.

CR 60h, 61h.

Location: Address 60h, 61h

Attribute: Read/Write

Power Well: VCC

Reset by: LRESET#

Default : 02h, E8h

Size: 16 bits

BIT	READ / WRITE	DESCRIPTION
7~0	R / W	These two registers select IR I/O base address <100h: FF8h> on eight-byte boundary.

CR 70h.

Location: Address 70h

Attribute: Read/Write

Power Well: VCC

Reset by: LRESET#

Default : 03h

Size: 8 bits

BIT	READ / WRITE	DESCRIPTION
7~4		Reserved.
3~0	R / W	These bits select IRQ resource for Serial Port 6.

CR F0h.

Location: Address F0h

Attribute: Read/Write

Power Well: VCC

Reset by: LRESET#

Default : 00h

Size: 8 bits



BIT	READ / WRITE	DESCRIPTION
7	R / W	0: Delay RXCLK for 5 ns for LG issue. 1: No delay of 5 ns for RXCLK.
6	R / W	0: IRQ is the level mode. 1: IRQ is the pulse mode for IRQ sharing function.
5	R / W	0: Using the original RX FIFO Error Indication signal (USR bit 7). 1: Using new RX FIFO Error Indication signal to solve some issues.
4~2	Reserved.	
1~0	R / W	Bits 1 0 0 0: UART F clock source is 1.8462 MHz (24 MHz / 13). 0 1: UART F clock source is 2 MHz (24 MHz / 12). 0 0: UART F clock source is 24 MHz (24 MHz / 1). 0 0: UART F clock source is 14.769 MHz (24 MHz / 1.625).

CR F2h. UARTF 9bit-mode Config Register

Location: Address F1h

Attribute: Read/Write

Power Well: VCC

Reset by: LRESET#

Default : 00h

Size: 8 bits

BIT	READ / WRITE	DESCRIPTION
7	R / W	En_auto_RX_ctrl 0: 9bitmode RX block function will pass all data or address byte and not compare any address byte. 1: 9bitmode RX block function could only receive address byte and compare the address bytes. (The address matched or not will issue IRQ. Refer to CRF6 description)
6	R / W	En_auto_only_addr_comp 0: When setting en_auto_RX_ctrl =1'b1, 9bitmode RX block function will compare the address byte and update the RX_ctrl Bit automatically. 1: When setting en_auto_RX_ctrl =1'b1, 9bitmode RX block function will only compare the address byte. But the RX_ctrl Bit will not be updated automatically by 9bitmode RX block function.
5	R / W	RST_low_time_sel 0: TX block will keep 1 bit time before inverting the driving signal. 1: TX block will keep 2 bit time before inverting the driving signal.
4	R / W	RS485_RTS_inv_sel 0: Automatic drive RTS# low when receiving data. Automatic drive RTS# high when transmitting data. 1: Automatic drive RTS# high when receiving data. Automatic drive RTS# low when transmitting data.

BIT	READ / WRITE	DESCRIPTION
3	R / W	En_auto_TX_ctrl 0: En_address_byte bit will not be automatic updated to "logic 0" by hardware after TX block sent address byte. 1: En_address_byte bit will be automatic updated to "logic 0" by hardware after TX block sent address byte.
2	R / W	En_auto_RX_ctrl 0: the address byte will be ingored by the receiver. 1: the address byte will be received into RX FIFO by the receiver.
1	R / W	En_RS485_RTS 0: RS232 driver 1: RS485 driver The 9bitmode TX block function will drive RTS_L to high when transmit data automatically
0	R / W	En_9bit_mode 0: normal UART function. 1: enable 9-bit mode function. (9bit-TX block use parity bit as address/Data bit when setting En_9bit_mode = 1'b1.)

CR F3h. UARTF 9bit-mode Slave Address Register

Location: Address F2h

Attribute: Read/Write

Power Well: VCC

Reset by: LRESET#

Default : 00h

Size: 8 bits

BIT	READ / WRITE	DESCRIPTION
7-0	R / W	Slave address

CR F4h. UARTF 9bit-mode Slave Mask Address Register

Location: Address F3h

Attribute: Read/Write

Power Well: VCC

Reset by: LRESET#

Default : FFh

Size: 8 bits

BIT	READ / WRITE	DESCRIPTION
7-0	R / W	Slave mask address

CR F5h. UARTF 9bit-mode Broadcase Address Register

Location: Address F4h

Attribute: Read/Write



Power Well: VCC

Reset by: LRESET#

Default : FFh

Size: 8 bits

BIT	READ / WRITE	DESCRIPTION
7-0	R / W	Broadcase Address

CR F6h. UARTF 9bit-mode Interrupt Control Register

Location: Address F5h

Attribute: Read/Write

Power Well: VCC

Reset by: LRESET#

Default : 02h

Size: 8 bits

BIT	READ / WRITE	DESCRIPTION
7-2	Reserved.	
1	R / W	IRQ_type_sel 0: 9bitemode RX block function will issue an IRQ when receive any address byte. (when IRQ_addr_Enable bit = 1) 1: 9bitemode RX block function will issue an IRQ when only receive the matched address byte. (when IRQ_addr_Enable bit = 1)
0	R / W	IRQ_addr_Enable 0: Disable UARTF 9bit-mode IRQ output. 1: Enalbe UARTF 9bit-mode IRQ output.

CR F7h. UARTF 9bit-mode IRQ Status Register

Location: Address F6h

Attribute: Read/Write

Power Well: VCC

Reset by: LRESET#

Default : 00h

Size: 8 bits

BIT	READ / WRITE	DESCRIPTION
7-1	Reserved.	
0	R / W	UARTF 9bit-mode Status Bit 0: UARTF 9bit-mode IRQ have not been triggered. 1: UARTF 9bit-mode IRQ have been triggered.

CR F8h. Extending UARTF Control Register

Location: Address F7h

Attribute: Read/Write

Power Well: VCC



Reset by: LRESET#

Default : 00h

Size: 8 bits

BIT	7	6	5	4	3	2	1	0
NAME	fifo_level_mode		Reserved		Reserved <i>(All should be set to 0)</i>			Enable_128_bytes_fifo
DEFAULT	0	0	0	0	0	0	0	0

BIT	DESCRIPTION																																									
7-6	fifo_level_mode: (Also check UFR register B7-6 definition)																																									
	<table border="1"> <thead> <tr> <th colspan="2"></th> <th colspan="4">RX FIFO INTERRUPT ACTIVE LEVEL (BYTES)</th> </tr> <tr> <th>UFR_BIT 7</th> <th>UFR_BIT 6</th> <th>FIFO_LEVEL_MODE (CRF8_B7:6 = 00)</th> <th>FIFO_LEVEL_MODE (CRF8_B7:6 = 01)</th> <th>FIFO_LEVEL_MODE (CRF8_B7:6 = 10)</th> <th>FIFO_LEVEL_MODE (CRF8_B7:6 = 11)</th> </tr> </thead> <tbody> <tr> <td>0</td> <td>0</td> <td>01</td> <td>16</td> <td>80</td> <td>112</td> </tr> <tr> <td>0</td> <td>1</td> <td>04</td> <td>32</td> <td>88</td> <td>116</td> </tr> <tr> <td>1</td> <td>0</td> <td>08</td> <td>48</td> <td>96</td> <td>120</td> </tr> <tr> <td>1</td> <td>1</td> <td>14</td> <td>64</td> <td>104</td> <td>124</td> </tr> </tbody> </table>								RX FIFO INTERRUPT ACTIVE LEVEL (BYTES)				UFR_BIT 7	UFR_BIT 6	FIFO_LEVEL_MODE (CRF8_B7:6 = 00)	FIFO_LEVEL_MODE (CRF8_B7:6 = 01)	FIFO_LEVEL_MODE (CRF8_B7:6 = 10)	FIFO_LEVEL_MODE (CRF8_B7:6 = 11)	0	0	01	16	80	112	0	1	04	32	88	116	1	0	08	48	96	120	1	1	14	64	104	124
		RX FIFO INTERRUPT ACTIVE LEVEL (BYTES)																																								
UFR_BIT 7	UFR_BIT 6	FIFO_LEVEL_MODE (CRF8_B7:6 = 00)	FIFO_LEVEL_MODE (CRF8_B7:6 = 01)	FIFO_LEVEL_MODE (CRF8_B7:6 = 10)	FIFO_LEVEL_MODE (CRF8_B7:6 = 11)																																					
0	0	01	16	80	112																																					
0	1	04	32	88	116																																					
1	0	08	48	96	120																																					
1	1	14	64	104	124																																					
5-4	Reserved.																																									
3-1	Reserved. <i>(All should be set to 0)</i>																																									
0	Extending fifo enable bit: 0: Disable 128bytes TX and RX FIFO. 1: Enable 128bytes TX and RX FIFO.																																									



23.20 Logical Device 14 (PORT80, IR)

CR 30h.

Location: Address 30h

Attribute: Read/Write

Power Well: VCC

Reset by: LRESET#

Default : 00h

Size: 8 bits

BIT	READ / WRITE	DESCRIPTION
7~1		Reserved.
0	R / W	0: IR is inactive. 1: IR is active.

CR 60h, 61h.

Location: Address 60h, 61h

Attribute: Read/Write

Power Well: VCC

Reset by: LRESET#

Default : 00h, 00h

Size: 16 bits

BIT	READ / WRITE	DESCRIPTION
7~0	R / W	These two registers select IR I/O base address <100h: FF8h> on eight-byte boundary.

CR 70h.

Location: Address 70h

Attribute: Read/Write

Power Well: VCC

Reset by: LRESET#

Default : 00h

Size: 8 bits

BIT	READ / WRITE	DESCRIPTION
7~4		Reserved.
3~0	R / W	These bits select IRQ resource for IR.

CR E0h. PORT80 UART Control Register

Location: Address E0h

Attribute: Read/Write

Power Well: VCC

Reset by: LRESET#

Default : 80h

Size: 8 bits



BIT	READ / WRITE	DESCRIPTION
7	R / W	TxEN (Transmit enable)
6-5	Reserved.	
4	R / W	PARE (Parity enable)
3	R / W	PARS (Parity Selection) 0: odd parity 1: even parity
2	R / W	STPS (Stop bit length selection) 0: 1 stop bit 1: 2 stop bits
1	R / W	CHAS (Character length selection) 0: 8 bits 1: 7bits
0	Reserved.	

CR E1h. PORT80 UART Status Register

Location: Address E1h

Attribute: Read/Write

Power Well: VCC

Reset by: LRESET#

Default : 00h

Size: 8 bits

BIT	READ / WRITE	DESCRIPTION
7-2	Reserved.	
1	R	TD (Transmit done status) When UART finish transmit, it would be 1 and auto clear by hardware
0	R	TBF (Transmit buffer full flag) 0: UART is idle 1: UART is transmitting

CR E2h. PORT80 UART Baud Rate Generator High Byte

Location: Address E2h

Attribute: Read/Write

Power Well: VCC

Reset by: LRESET#

Default : 00h

Size: 8 bits

BIT	READ / WRITE	DESCRIPTION
7-0	R / W	BRGL (Baud rate generator high byte)

**CR E3h. PORT80 UART Baud Rate Generator Low Byte**

Location: Address E3h

Attribute: Read/Write

Power Well: VCC

Reset by: LRESET#

Default : 10h

Size: 8 bits

BIT	READ / WRITE	DESCRIPTION
7-0	R / W	BRGL (Baud rate generator low byte) Baud Rate = 2MHz / ({BRGH, BRGL} + 1)

CR E4h. PORT80 UART Transmit Buffer

Location: Address E4h

Attribute: Read/Write

Power Well: VCC

Reset by: LRESET#

Default : 00h

Size: 8 bits

BIT	READ / WRITE	DESCRIPTION
7-0	R / W	UARTBUF (UART Transmit buffer)

CR F0h.

Location: Address F0h

Attribute: Read/Write

Power Well: VCC

Reset by: LRESET#

Default : 00h

Size: 8 bits

BIT	READ / WRITE	DESCRIPTION
7	R / W	0: Delay RXCLK for 5 ns for LG issue. 1: No delay of 5 ns for RXCLK.
6	R / W	0: IRQ is the level mode. 1: IRQ is the pulse mode for IRQ sharing function.
5	R / W	0: Using the original RX FIFO Error Indication signal (USR bit 7). 1: Using new RX FIFO Error Indication signal to solve some issues.
4~2	Reserved.	
1~0	R / W	Bits 1 0 0 0: IR clock source is 1.8462 MHz (24 MHz / 13). 0 1: IR clock source is 2 MHz (24 MHz / 12). 0 0: IR clock source is 24 MHz (24 MHz / 1). 0 0: IR clock source is 14.769 MHz (24 MHz / 1.625).

**CR F1h.**

Location: Address F1h

Attribute: Read/Write

Power Well: VCC

Reset by: LRESET#

Default : 00h

Size: 8 bits

BIT	READ / WRITE	DESCRIPTION
7-6	Reserved.	
5-3	R / W	IRMODE => IR function mode selection. See the table below.
2	R / W	IR half / full duplex function selection. 0: IR function is Full Duplex. 1: IR function is Half Duplex.
1	R / W	0: IRTX pin of IR function in normal condition. 1: Inverse IRTX pin of IR function.
0	R / W	0: IRRX pin of IR function in normal condition. 1: Inverse IRRX pin of IR function.

IR MODE	IR FUNCTION	IRTX	IRRX
00X	Disable	Tri-state	High
010*	IrDA	Active pulse 1.6 μ S	Demodulation into SINB/IRRX
011*	IrDA	Active pulse 3/16 bit time	Demodulation into SINB/IRRX
100	ASK-IR	Inverting IRTX/SOUTB pin	Routed to SINB/IRRX
101	ASK-IR	Inverting IRTX/SOUTB & 500 KHZ clock	Routed to SINB/IRRX
110	ASK-IR	Inverting IRTX/SOUTB	Demodulation into SINB/IRRX
111*	ASK-IR	Inverting IRTX/SOUTB & 500 KHZ clock	Demodulation into SINB/IRRX

Note: The notation is normal mode in the IR function.



23.21 Logical Device 15 (FADING LED)

CR E0.Fading Maximun Duty Cycle Value Register

Location: Address E0h

Attribute: Read/Write

Power Well: VSB

Reset by: RSMRST#

Default : FFh

Size: 8 bits

BIT	READ / WRITE	DESCRIPTION
7-0	R / W	Fading_maxval Fading led → Intel_led_clk_sel = 1: 250KHz and Pled_en=1 The maximum duty cycle value. Solid led → Pled_clk_sel = 1: 250KHz and Pled_en=0 <duty cycle> 8'h01: 1/255 = 0.3% 8'h02: 2/255 = 0.7% ... 8'h40: 64/255 = 25.1% ... 8'hFF: 255/255 = 100% Blink led → Pled_clk_sel = 0: 4Hz <duty cycle> 8'h01: 1/255 = 0.3% 8'h02: 2/255 = 0.7% ... 8'h40: 64/255 = 25.1% ... 8'hFF: 255/255 = 100%

CR E1. Fading Middle Duty Cycle Value Register

Location: Address E1h

Attribute: Read/Write

Power Well: VSB

Reset by: RSMRST#

Default : 3Fh

Size: 8 bits

BIT	READ / WRITE	DESCRIPTION
7-0	R / W	Fading_midval turning point, the duty cycle value between the minimum and maximum duty cycle value.

CR E2. Fading Minimun Duty Cycle Value Register

Location: Address E2h



Attribute: Read/Write

Power Well: VSB

Reset by: RSMRST#

Default : 01h

Size: 8 bits

BIT	READ / WRITE	DESCRIPTION
7-0	R / W	Fading_minval The minimum duty cycle value.

CRE3. Fading Increase Duty Cycle Value Register

Location: Address E3h

Attribute: Read/Write

Power Well: VSB

Reset by: RSMRST#

Default : 11h

Size: 8 bits

BIT	READ / WRITE	DESCRIPTION
7-4	R / W	Fading_duty_inc_h The increased duty cycle value between the turning point and the maximum duty cycle value.
3-0	R / W	Fading_duty_inc_l The increased duty cycle value between the minimum duty cycle value and turning point.

CR E4. Fading Decrease Duty Cycle Value Register

Location: Address E4h

Attribute: Read/Write

Power Well: VSB

Reset by: RSMRST#

Default : 11h

Size: 8 bits

BIT	READ / WRITE	DESCRIPTION
7-4	R / W	Fading_duty_dec_h The decreased duty cycle value between the maximum duty cycle value and the turning point.
3-0	R / W	Fading_duty_dec_l The decreased duty cycle value between the turning point and the minimum duty cycle value.

CR E5. Fading Configure Register

Location: Address E5h

Attribute: Read/Write

Power Well: VSB

Reset by: RSMRST#

Default : 02h

Size: 8 bits



BIT	READ / WRITE	DESCRIPTION
7-4	R / W	Fading_prgval Repeat each duty cycle value for a few time.
3-2	R / W	Fading_extend 2'b00: No extend. 2'b01: Only extend the minimum duty cycle value for a few time. 2'b10: Only extend the maximum duty cycle value for a few time. 2'b11: Both extend the minimum and the maximum duty cycle value for a few time.
1	R / W	Fading_clk_sel 1: 250KHz 0: 4Hz
0	R / W	Fading_en 1: fading led 0: solid led

CRE6. Fading Light extend Register

Location: Address E6h

Attribute: Read/Write

Power Well: VSB

Reset by: RSMRST#

Default : 00h

Size: 8 bits

BIT	READ / WRITE	DESCRIPTION
7-0	R / W	Fading_light_ext The time for extend the maximum duty cycle value.

CR E7. Fading Dark extend Register

Location: Address E7h

Attribute: Read/Write

Power Well: VSB

Reset by: RSMRST#

Default : 00h

Size: 8 bits

BIT	READ / WRITE	DESCRIPTION
7-0	R / W	Fading_dark_ext The time for extend the minimum duty cycle value.

CR E8. Fading Frequency Divide Register

Location: Address E8h

Attribute: Read/Write

Power Well: VSB

Reset by: RSMRST#

Default : 01h

Size: 8 bits

BIT	READ / WRITE	DESCRIPTION
-----	--------------	-------------



BIT	READ / WRITE	DESCRIPTION
7-0	R / W	Fading freq_div led_clk_sel =1: 250KHz 8'h01: 250Khz/1=250Khz 8'h02: 250Khz/2=125Khz ... 8'hFF: 250Khz/255=0.98Khz Fading_clk_sel =0: 4Hz 8'h00: always high 8'h01: always low 8'h02: 4Hz 8'h03: 2Hz 8'h04: 1Hz 8'h05: 1/2Hz 8'h06: 1/4Hz 8'h07: always high others: always low

CR E9. Suspend LED S5 Enable Register

Location: Address E9h

Attribute: Read/Write

Power Well: VSB

Reset by: RSMRST#

Default : 00h

Size: 8 bits

BIT	READ / WRITE	DESCRIPTION
7-1	Reserved	
0	R / W	Suspend led S5 enable (1:Enable, 0:Disbale)



23.22 Logical Device 16 (DEEP SLEEP)

CR 30h. Deep Sleep configuration register

Location: Address 30h

Attribute: Read/Write

Power Well: VRTC

Reset by: Battery reset

Default : 20h

Size: 8 bits

BIT	READ / WRITE	DESCRIPTION
7		Reserved.
6	R / W	Set to 0, the RSMRST_SYS detect PSOUT# voltage. Set to 1, the RSMRST_SYS detect PCHVSB voltage.
5	R / W	deep_s3_opt Set to 0, when enter Deep S3 state, the SUS_WARN_5VDUAL will keep low. Set to 1, when enter Deep S3 state, the SUS_WARN_5VDUAL will follow DSW sequence.
4	R / W	dsw_wake_opt (test mode) Set to 0, the PSOUT# will assert until SLPS3# high when deep s5 wakeup event happened. Set to 1, the PSOUT# will assert until RSMRST_L high and SLP_SUS_L high when deep s5 wakeup event happened. PS. This bit only active when PCH_DSW_EN & (Deep S5 Enable Deep S3 Enable)
3	R / W	PCH_DSW_EN Set to 0, if PCH disable DSW (Deep Sleep Well) function. Set to 1, if PCH enable DSW (Deep Sleep Well) function.
2	R / W	The pin Deep_S5#_Delay option. Set to 0, If Deep_S5 de-asserts, then Deep_S5#_Dleay will de-assert after 50ms. Set to 1, If Deep_S5 de-asserts, then Deep_S5#_Dleay will de-assert after 100ms..
1	R / W	Deep S3 Enable Set to 0, If SLP_S3# state, will not enter Deep S3 state. Set to 1, If SLP_S3# state, will enter Deep S3 state.
0	R / W	Deep S5 Enable Set to 0, If SLP_S5# state, will not enter Deep S5 state. Set to 1, If SLP_S5# state, will enter Deep S5 state.

CR E0h. Deep Sleep wake up PSOUT# delay time

Location: Address E0h

Attribute: Read/Write

Power Well: VSB

Reset by: RSMRST#



Default : **20h** (Default: 512ms)

Size: 8 bits

BIT	READ / WRITE	DESCRIPTION
7~6	Reserved.	
5~0	R / W	Deep Sleep wake up PSOUT# delay time. When system wake up from deep sleep state, IO will issue a low pulse via PSOUT# after SYS_3VSB and wait a delay time. DELAY TIME = (Setting Value) * 16ms Example : maximum delay time = (3F) _{hex} * 16ms = 1008ms

CR E1h. Deep Sleep wake up PSOUT# pulse width

Location: Address E1h

Attribute: Read/Write

Power Well: VSB

Reset by: RSMRST#

Default : **04h** (Default: 128 ms)

Size: 8 bits

BIT	READ / WRITE	DESCRIPTION
7	R/W	Deep_S5_2 signal status. 0: Deep_S5_2 signal always keep low. 1: Deep_S5_2 signal follow Deep_S5_1 signal.
6	Reserved	
5	SUSLED	SUSLED Enable: 0:Disable (default and output low) 1: Enable
4	Reserved	
3~0	R / W	Deep Sleep wake up PSOUT# pulse width. When system wake up from deep sleep state, IO will issue a low pulse via PSOUT#.. Pulse Width = (Setting Value) * 32ms Example : maximum pulse width = (F) _{hex} * 32ms = 480ms

CR E2h. Deep Sleep Delay Time Control

Location: Address E2h

Attribute: Read/Write

Power Well: VSB

Reset by: RSMRST#

Default : 05h (Default: 5 sec)

Size: 8 bits

BIT	READ / WRITE	DESCRIPTION
7	R / W	0: The unit of deep sleep delay time is second. 1: The unit of deep sleep delay time is Minute.
6~0	R / W	Deep Sleep Delay Time Control. When system leaves S0 State, IO will wait a delay time before entering into Deep Sleep State. Example: maximum delay time = 127 second/minute



24. SPECIFICATIONS

24.1 Absolute Maximum Ratings

SYMBOL	PARAMETER	RATING	UNIT
3VCC	Power Supply Voltage (3.3V)	-0.3 to 3.6	V
VI	Input Voltage	-0.3 to 3VCC+0.3	V
	Input Voltage (5V tolerance)	-0.3 to 5.5	V
TA	Operating Temperature	-40 to +85	°C
TSTG	Storage Temperature	-55 to +150	°C

Note: Exposure to conditions beyond those listed under Absolute Maximum Ratings may adversely affect the life and reliability of the device.

24.2 DC CHARACTERISTICS

($T_A = 0^\circ\text{C}$ to $+70^\circ\text{C}$, $V_{DD} = 3.3\text{V} \pm 5\%$, $V_{SS} = 0\text{V}$)

PARAMETER	SYM	MIN	TYP	MAX.	UNIT	CONDITIONS
Battery Quiescent Current	IBAT			2.4	μA	$V_{BAT} = 2.5\text{V}$
ACPI Stand-by Power Supply Quiescent Current	IVSB			8.0	mA	$V_{SB} = 3.3\text{V}$, All ACPI pins are not connected.
VCC Quiescent Current	IVCC			25	mA	$V_{SB} = 3.3\text{V}$ $V_{CC} (AVCC) = 3.3\text{V}$ LRESET = High IOCLK = 48MHz CASEOPEN Pull-Up to V_{BAT}
Vtt Quiescent Current	IVTT			1	mA	$V_{SB} = 3.3\text{V}$ $V_{CC} (AVCC) = 3.3\text{V}$ $V_{TT} = 1.2\text{V}$ LRESET = High IOCLK = 48MHz CASEOPEN Pull-Up to V_{BAT}
AIN – Analog input						
AOUT – Analog output						
IN_{tp3} – 3.3V TTL-level input pin						

PARAMETER	SYM	MIN	TYP	MAX.	UNIT	CONDITIONS
Input Low Voltage	V _{IL}			0.8	V	
Input High Voltage	V _{IH}	2.0			V	
Input High Leakage	I _{LIH}			+10	μA	V _{IN} = 3.3V
Input Low Leakage	I _{LIL}			-10	μA	V _{IN} = 0 V
IN_{tsp3} – 3.3V TTL-level, Schmitt-trigger input pin						
Input Low Threshold Voltage	V _{t-}	0.5	0.8	1.1	V	V _{CC} = 3.3 V
Input High Threshold Voltage	V _{t+}	1.6	2.0	2.4	V	V _{CC} = 3.3 V
Hysteresis	V _{TH}	0.5	1.2		V	V _{CC} = 3.3 V
Input High Leakage	I _{LIH}			+10	μA	V _{IN} = 3.3 V
Input Low Leakage	I _{LIL}			-10	μA	V _{IN} = 0 V
IN_{gp5} – 5V GTL-level input pin						
Input Low Voltage	V _{IL}		0.72		V	
Input High Voltage	V _{IH}		0.72		V	
Input High Leakage	I _{LIH}			+10	μA	V _{IN} = 3.3V
Input Low Leakage	I _{LIL}			-10	μA	V _{IN} = 0 V
IN_{tp5} – 5V TTL-level input pin						
Input Low Voltage	V _{IL}			0.8	V	
Input High Voltage	V _{IH}	2.0			V	
Input High Leakage	I _{LIH}			+10	μA	V _{IN} = 3.3V
Input Low Leakage	I _{LIL}			-10	μA	V _{IN} = 0 V
IN_{tscup5} – 5V TTL-level, Schmitt-trigger input buffer with controllable pull-up						
Input Low Threshold Voltage	V _{t-}	0.5	0.8	1.1	V	V _{CC} = 3.3 V
Input High Threshold Voltage	V _{t+}	1.6	2.0	2.4	V	V _{CC} = 3.3 V
Hysteresis	V _{TH}	0.5	1.2		V	V _{CC} = 3.3 V
Input High Leakage	I _{LIH}			+10	μA	V _{IN} = 3.3 V
Input Low Leakage	I _{LIL}			-10	μA	V _{IN} = 0 V
IN_{tsp5} – 5V TTL-level, Schmitt-trigger input pin						
Input Low Threshold Voltage	V _{t-}	0.5	0.8	1.1	V	V _{CC} = 3.3 V
Input High Threshold Voltage	V _{t+}	1.6	2.0	2.4	V	V _{CC} = 3.3 V
Hysteresis	V _{TH}	0.5	1.2		V	V _{CC} = 3.3 V
Input High Leakage	I _{LIH}			+10	μA	V _{IN} = 3.3 V
Input Low Leakage	I _{LIL}			-10	μA	V _{IN} = 0 V
IN_{tdp5} – 5V TTL-level input pin with internal pull-down resistor						
Input Low Voltage	V _{IL}			0.8	V	

PARAMETER	SYM	MIN	TYP	MAX.	UNIT	CONDITIONS
Input High Voltage	V _{IH}	2.0			V	
Input High Leakage	I _{LIH}			+10	μA	V _{IN} = 3.3V
Input Low Leakage	I _{LIL}			-10	μA	V _{IN} = 0 V
O8 – Output pin with 8mA source-sink capability						
Output Low Voltage	V _{OL}			0.4	V	I _{OL} = 8 mA
Output High Voltage	V _{OH}	2.4			V	I _{OH} = -8 mA
OD8 – Open-drain output pin with 8mA sink capability						
Output Low Voltage	V _{OL}			0.4	V	I _{OL} = 8 mA
O12 – Output pin with 12mA source-sink capability						
Output Low Voltage	V _{OL}			0.4	V	I _{OL} = 12 mA
Output High Voltage	V _{OH}	2.4			V	I _{OH} = -12 mA
OD12 – Open-drain output pin with 12mA sink capability						
Output Low Voltage	V _{OL}			0.4	V	I _{OL} = 12 mA
O24 – Output pin with 24mA source-sink capability						
Output Low Voltage	V _{OL}			0.4	V	I _{OL} = 24 mA
Output High Voltage	V _{OH}	2.4			V	I _{OH} = -24 mA
OD24 – Open-drain output pin with 24mA sink capability						
Output Low Voltage	V _{OL}			0.4	V	I _{OL} = 24 mA
O48 – Output pin with 48mA source-sink capability						
Output Low Voltage	V _{OL}			0.4	V	I _{OL} = 48 mA
Output High Voltage	V _{OH}	2.4			V	I _{OH} = -48 mA
OD48 – Open-drain output pin with 48mA sink capability						
Output Low Voltage	V _{OL}			0.4	V	I _{OL} = 48 mA
I/O_{V3} – Bi-direction pin with source capability of 6 mA and sink capability of 1 mA for INTEL® PECL						
Input Low Voltage	V _{IL}	0.275*V _{tt}		0.5*V _{tt}	V	
Input High Voltage	V _{IH}	0.55*V _{tt}		0.725*V _{tt}	V	
Output Low Voltage	V _{OL}			0.25*V _{tt}	V	
Output High Voltage	V _{OH}	0.75*V _{tt}			V	
Hysteresis	V _{Hys}	0.1*V _{tt}			V	
O12cu – Output pin 12mA source-sink capability with controllable pull-up						
Output Low Voltage	V _{OL}			0.4	V	I _{OL} = 12 mA
Output High Voltage	V _{OH}	2.4			V	I _{OH} = -12 mA
OD12cu – Open-drain 12mA sink capability output pin with controllable pull-up						
Output Low Voltage	V _{OL}			0.4	V	I _{OL} = 12 mA

25. AC CHARACTERISTICS

25.1 Power On / Off Timing

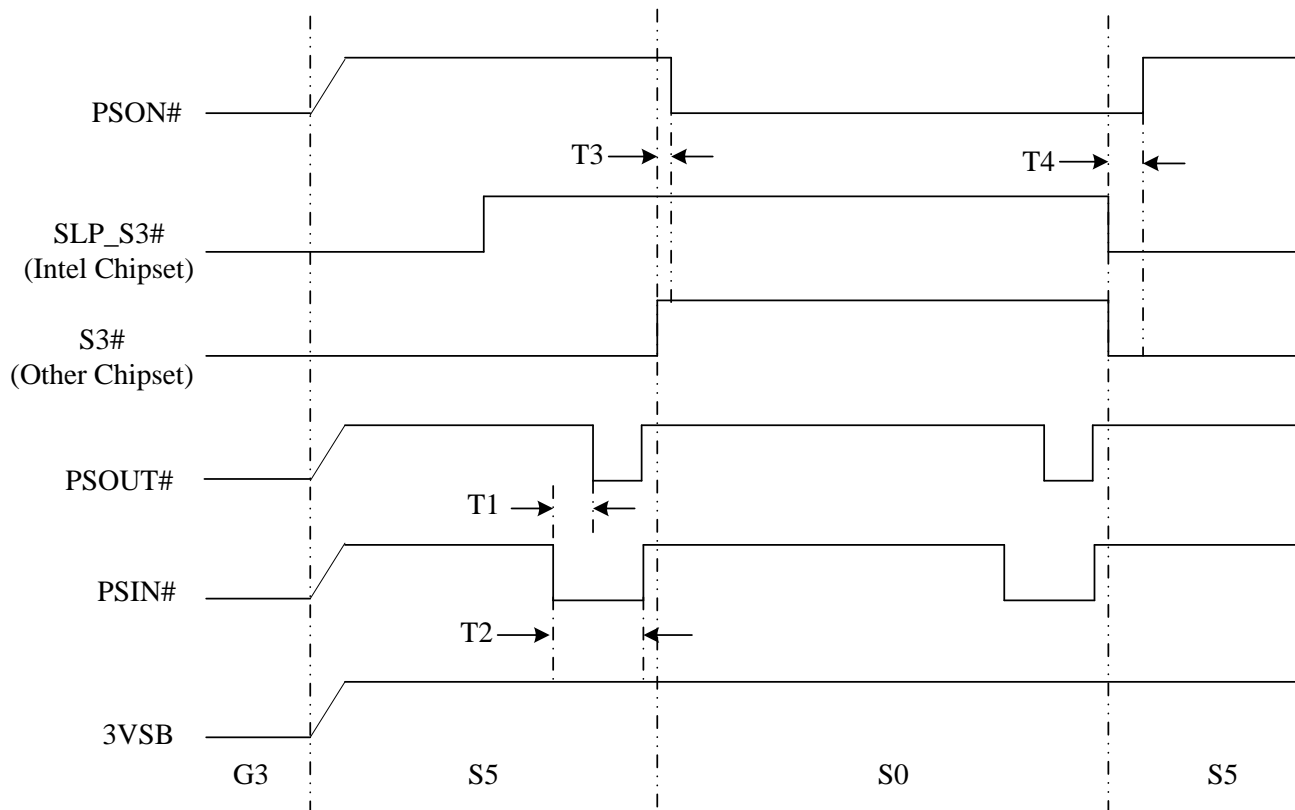

	T1	T2	T3	T4
IDEAL TIMING	64ms	Over 64ms at least	< 10ns	32ms

25.2 AC Power Failure Resume Timing

(1) Logical Device A, CR [E4h] bits [6:5] =00 means "OFF" state
("OFF" means the system is always turned off after the AC power loss recovered.)

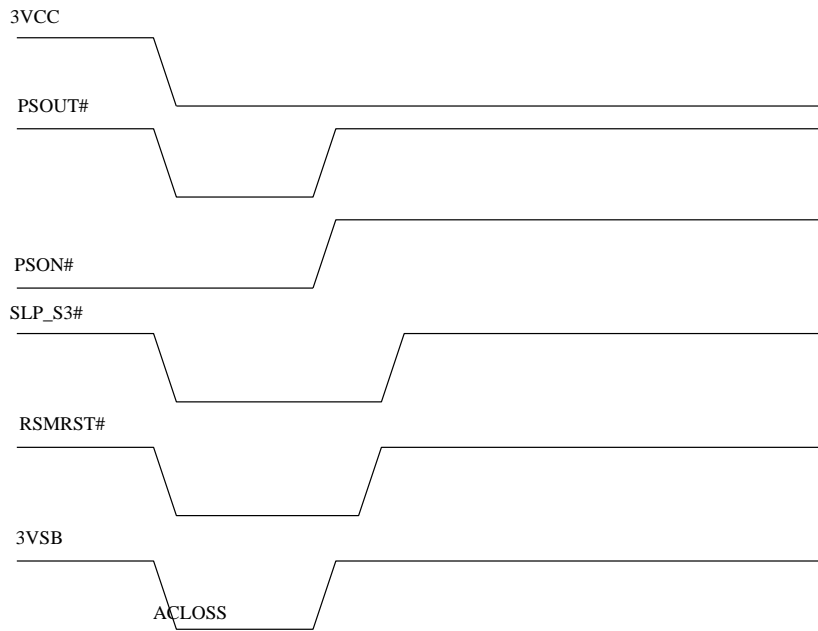



(2) Logical Device A, CR [E4h] bits [6:5]=01 means “ON” state.
 (“ON” means the system is always turned on after AC power loss recovered.)

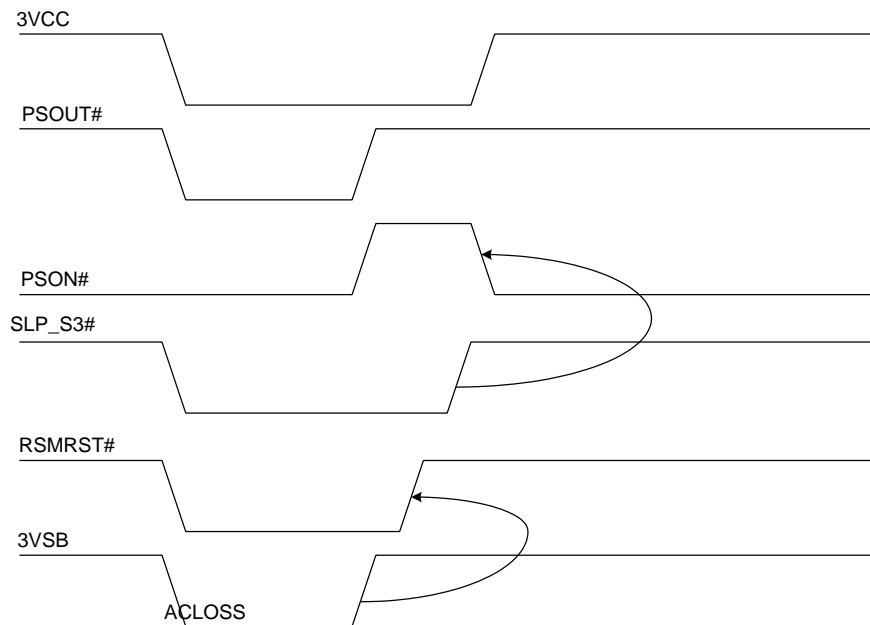

**** What's the definition of former state at AC power failure?**

1) The previous state is "ON"

VCC falls to 2.6V and SLP_S3# keeps at VIH 2.0V

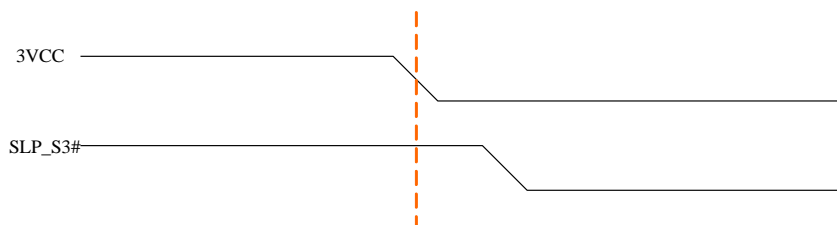

2) The previous state is "OFF"

VCC fall to 2.6V and SLP_S3# keeps at VIL 0.8V

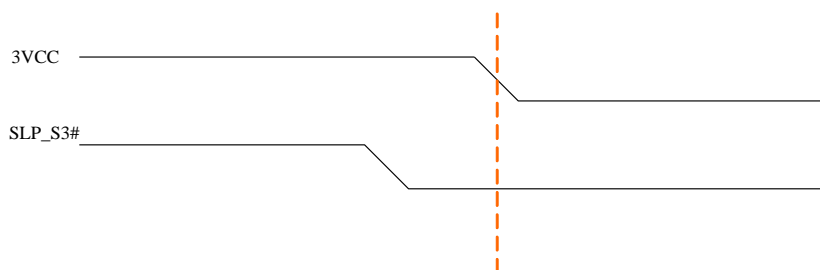

To ensure that VCC does not fall faster than VSB in various ATX Power Supplies, the NCT6102D / NCT6106D adds the option of "user define mode" for the pre-defined state before AC power failure. BIOS can set the pre-defined state for the system to be "On" or "Off". According to this setting, the system chooses the state after the AC power recovery.

Please refer to the descriptions of bit 6~5 of CR E4h and bit 4 of CR E6h in Logical Device A.

CR E4h

BIT	READ/WRITE	DESCRIPTION
6~5	R / W	Power-loss control bits => (VBAT) 0 0: System always turns off when it returns from power-loss state. 0 1: System always turns on when it returns from power-loss state. 1 0: System turns off / on when it returns from power-loss state depending on the state before the power loss. 1 1: User defines the resuming state before power loss.(refer to Logic Device A, CRE6[4])

CR E6h

BIT	READ/WRITE	DESCRIPTION
4	R / W	Power loss Last State Flag. (VBAT) 0: ON 1: OFF

25.3 Clock Input Timing

PARAMETER	48MHZ / 24MHZ		UNIT
	MIN	MAX	
Cycle to cycle jitter		300/500	ps
Duty cycle	45	55	%

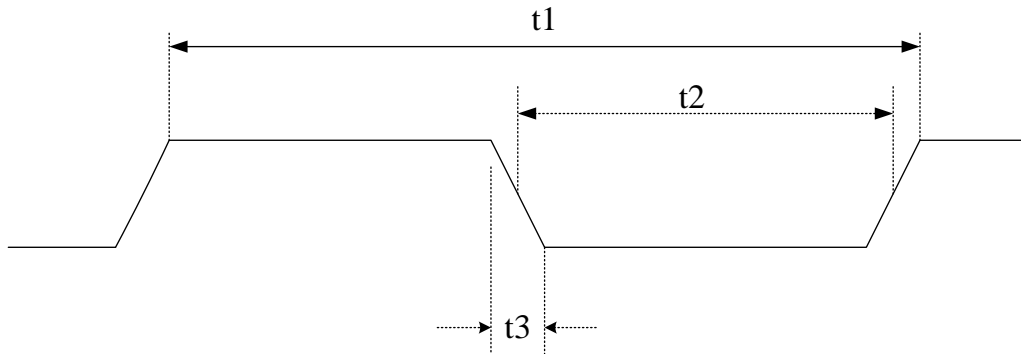

PARAMETER	DESCRIPTION	48MHZ / 24MHZ			UNIT
		MIN	TYP	MAX	
t1	Clock cycle time		20.8 / 41.7		ns
t2	Clock high time/low time	9 / 19	10 / 21		ns
t3	Clock rising time/falling time (0.4V~2.4V)			3	ns

25.4 PECEI Timing

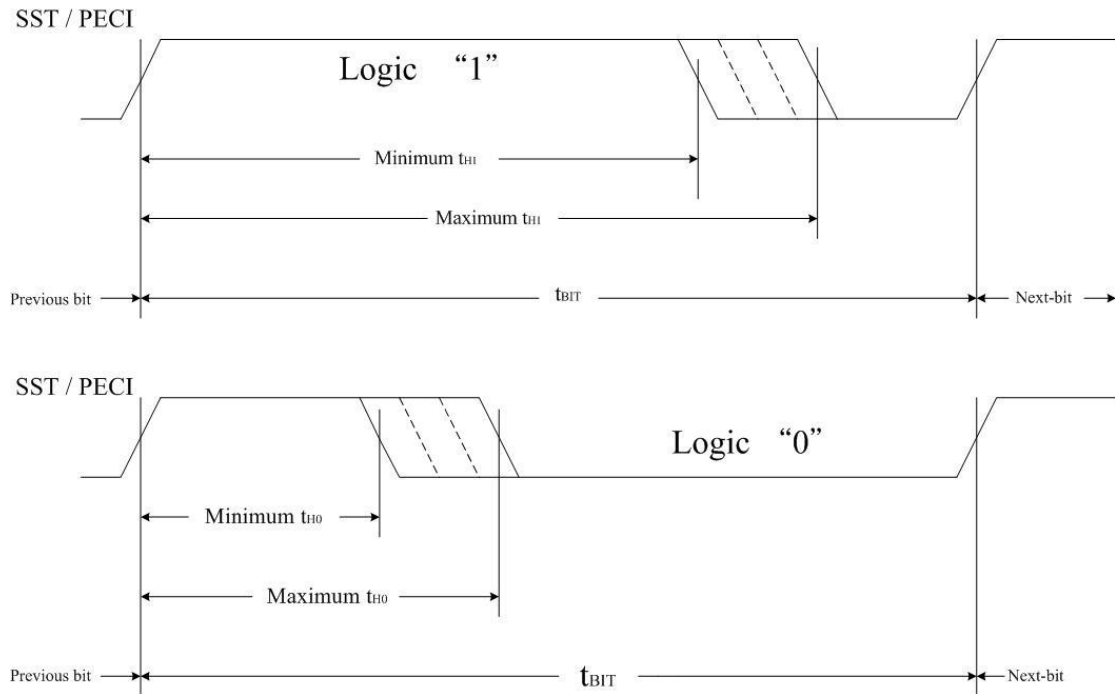

SYMBOL		MIN	TYP	MAX	UNITS
t _{BIT}	Client	0.495		500	μs
	Originator	0.495		250	
t _{H1}		0.6	3/4	0.8	× t _{BIT}
t _{H0}		0.2	1/4	0.4	× t _{BIT}

25.5 SMBus Timing

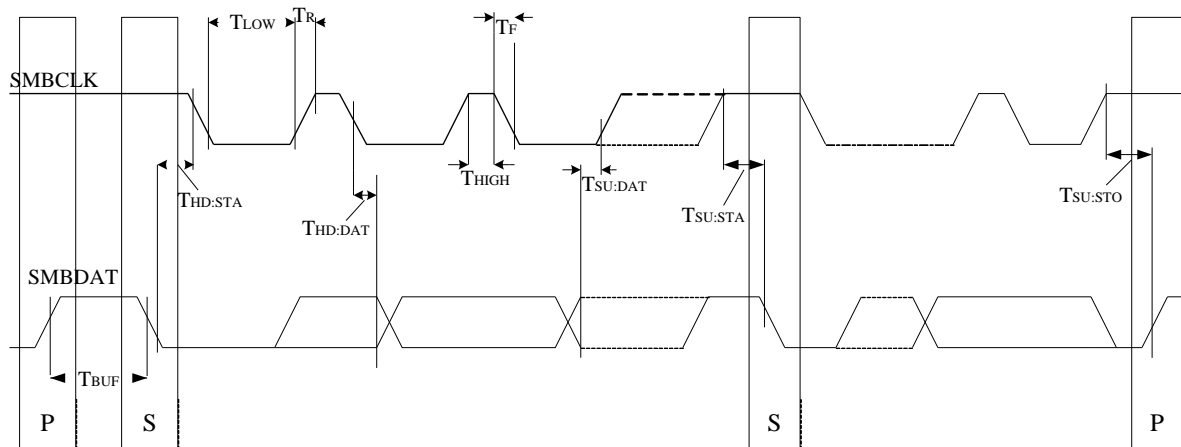



25.6 Floppy Disk Drive Timing

FDC: Data rate = 1MB, 500KB, 300KB, 250KB/sec.

PARAMETER	SYM.	MIN.	TYP. (NOTE 1)	MAX.	UNIT
DIR# setup time to STEP#	T _{DST}	1.0/1.6 /2.0/4.0			μS
DIR# hold time from STEP#	T _{STD}	24/40 /48/96			μS
STEP# pulse width	T _{STP}	6.8/11.5 /13.8/27. 8	7/11.7 /14/28	7.2/11.9 /14.2/28. 2	μS
STEP# cycle width	T _{SC}	NOTE 2	NOTE 2	NOTE 2	mS
INDEX# pulse width	T _{IDX}	125/250 /417/500			nS
RDATA# pulse width	T _{RD}	40			nS
WD# pulse width	T _{WD}	100/185 /225/475	125/210 /250/500	150/235 /275/525	nS

Notes:

1. Typical values for T = 25°C and normal supply voltage.
2. Programmable from 0.5 mS through 32 mS as described in step rate table.
(Please refer to the description of the SPECIFY command set.)

Step Rate Table

DATA RATE SRT	1MB/S	500KB/S	300KB/S	250KB/S
0	8	16	26.7	32
1	7.5	15	25	30
...
E	1.0	2	3.33	4
F	0.5	1	1.67	2

Floppy Disk Driving Timing

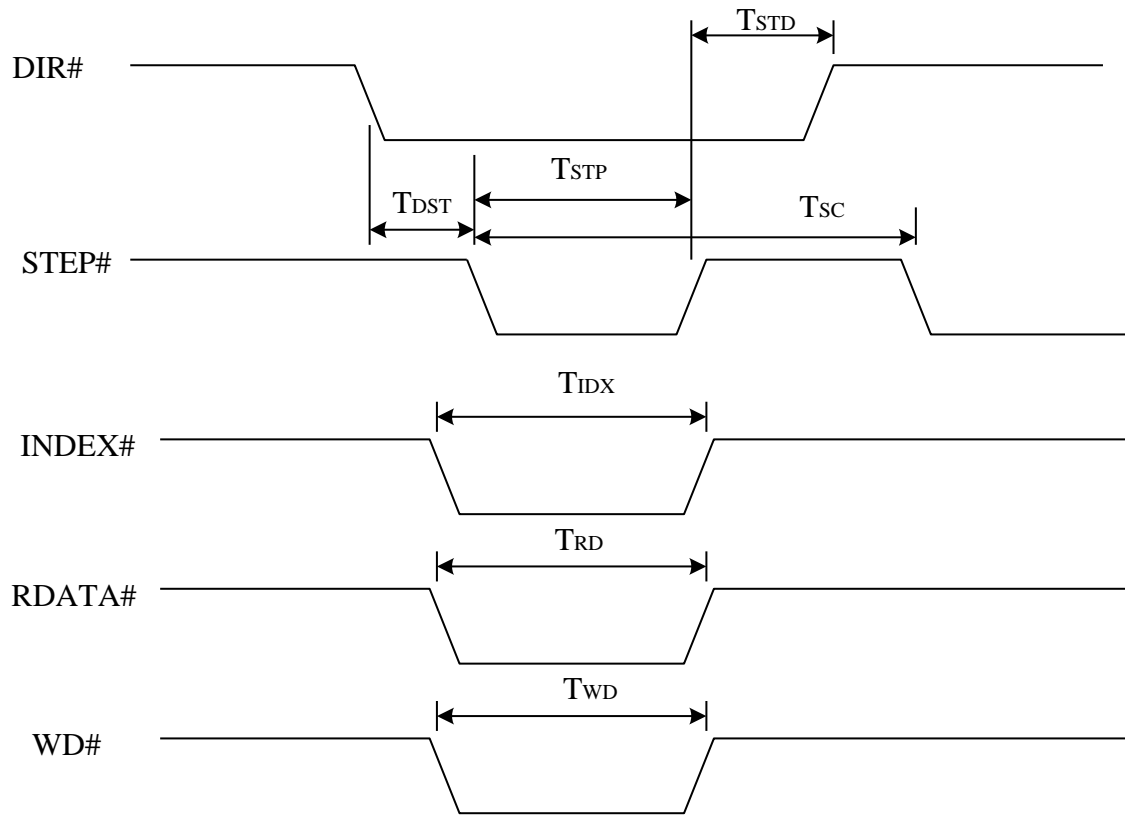



25.7 UART/Parallel Port

PARAMETER	SYMBOL	TEST CONDITIONS	MIN.	MAX.	UNIT
Delay from Stop to Set Interrupt	TSINT		9/16		Baud Rate
Delay from $\overline{\text{IOR}}$ Reset Interrupt	TRINT		9	1000	nS
Delay from Initial IRQ Reset to Transmit Start	TIRS		1/16	8/16	Baud Rate
Delay from to Reset interrupt	THR			175	nS
Delay from Initial $\overline{\text{IOW}}$ to interrupt	TSI		9/16	16/16	Baud Rate
Delay from Stop to Set Interrupt	TSTI			8/16	Baud Rate
Delay from $\overline{\text{IOR}}$ to Reset Interrupt	TIR		8	250	nS
Delay from $\overline{\text{IOR}}$ to Output	TMWO		6	200	nS
Set Interrupt Delay from Modem Input	TSIM		18	250	nS
Reset Interrupt Delay from $\overline{\text{IOR}}$	TRIM		9	250	nS
Baud Divisor	N	100 pF Loading		$2^{16}-1$	

UART Receiver Timing

Receiver Timing

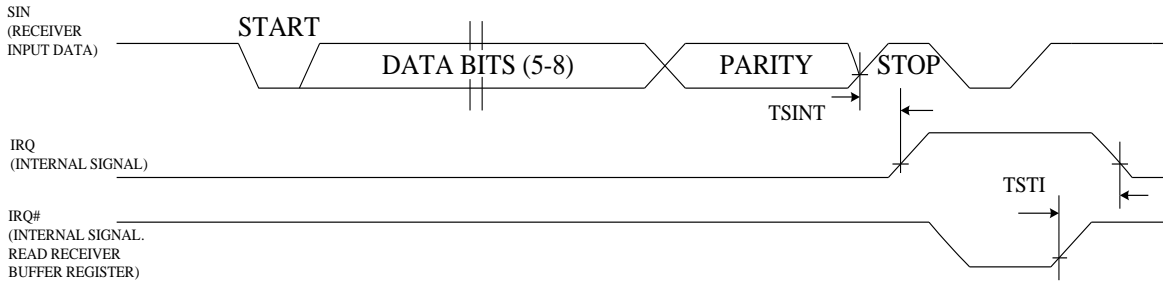

UART Transmitter Timing

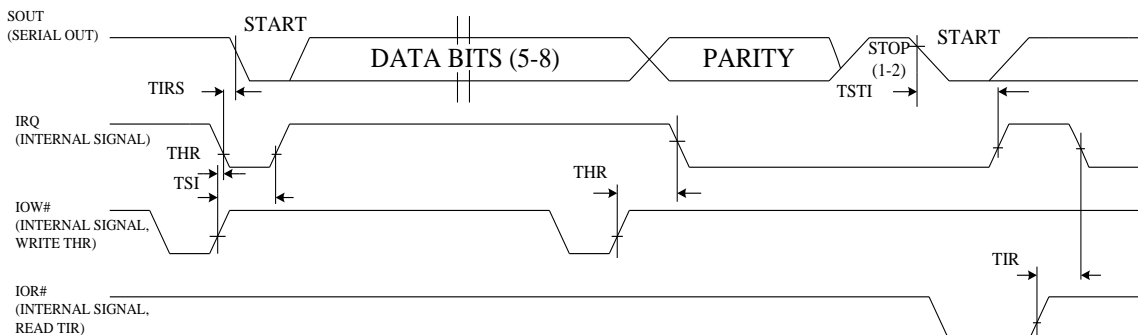

25.8 Modem Control Timing

Modem Control Timing

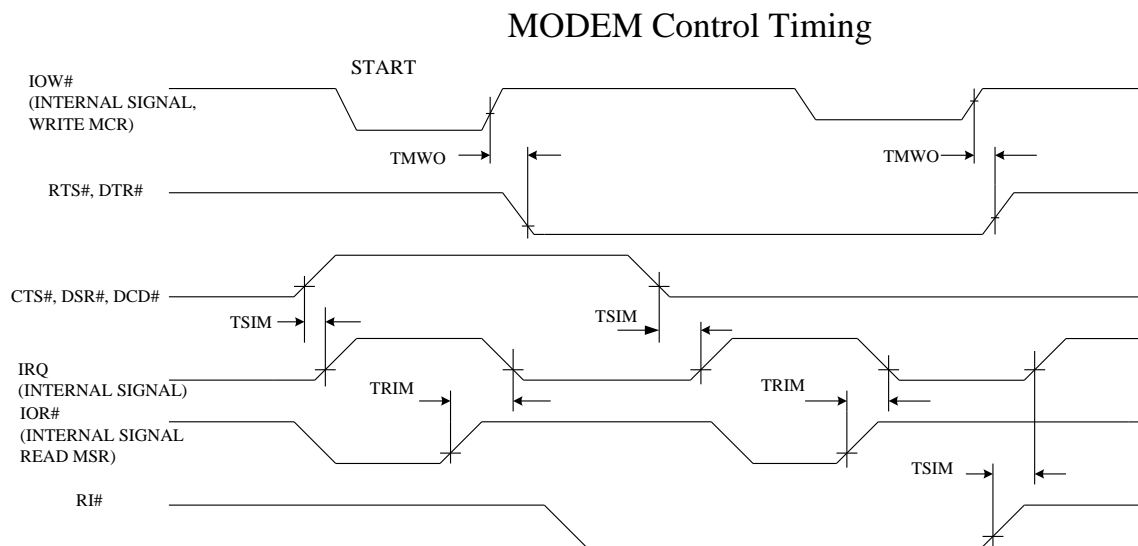

25.9 Parallel Port Mode Parameters

PARAMETER	SYM.	MIN.	TYP.	MAX.	UNIT
PD0-7, INDEX, STROBE, AUTOFD Delay from IOW	t1			100	nS
IRQ Delay from ACK, nFAULT	t2			60	nS
IRQ Delay from IOW	t3			105	nS
IRQ Active Low in ECP and EPP Modes	t4	200		300	nS
ERROR Active to IRQ Active	t5			105	nS
PARAMETER	SYM.	MIN.	TYP.	MAX.	UNIT
PD0-7, INDEX, STROBE, AUTOFD Delay from IOW	t1			100	nS
IRQ Delay from ACK, nFAULT	t2			60	nS
IRQ Delay from IOW	t3			105	nS
IRQ Active Low in ECP and EPP Modes	t4	200		300	nS
ERROR Active to IRQ Active	t5			105	nS

25.9.1 Parallel Port Timing

Parallel Port Timing

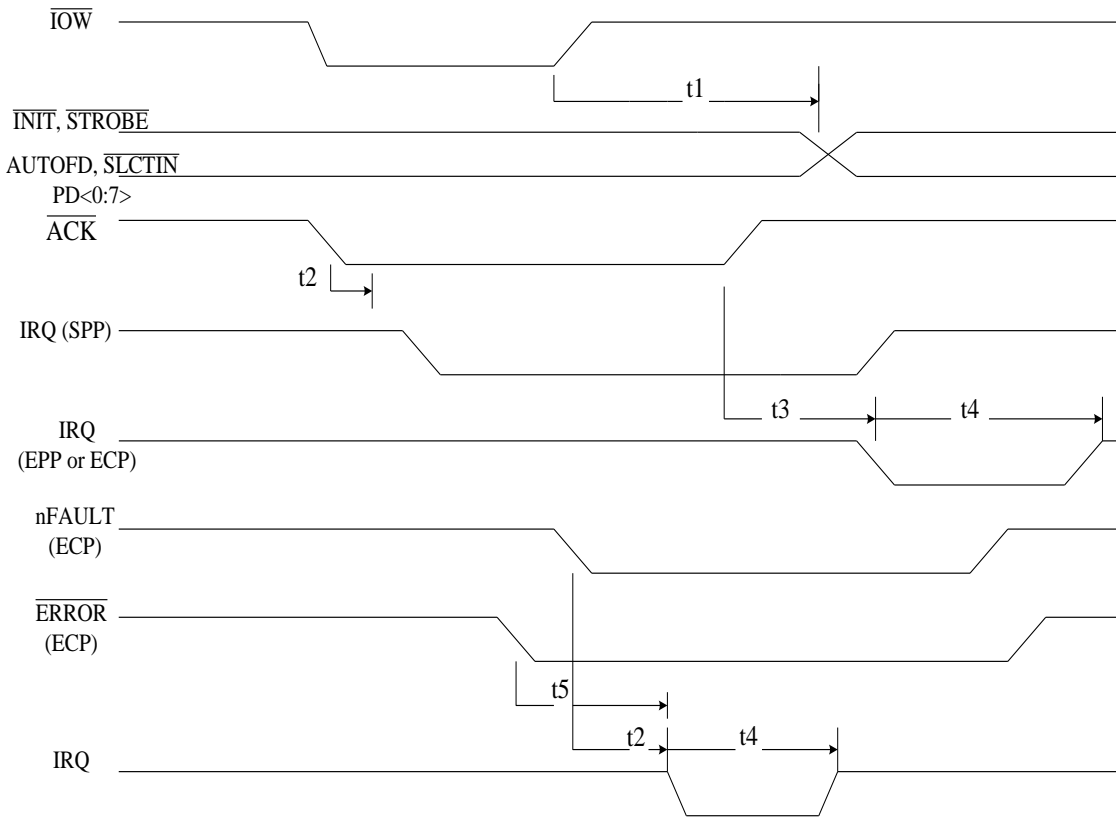

25.9.2 EPP Data or Address Read Cycle Timing Parameters

PARAMETER	SYM.	MIN.	MAX.	UNIT
$\overline{\text{WAIT}}$ Asserted to $\overline{\text{WRITE}}$ Deasserted	t14	0	185	nS
Deasserted to $\overline{\text{WRITE}}$ Modified	t15	60	190	nS
$\overline{\text{WAIT}}$ Asserted to PD Hi-Z	t17	60	180	nS
Command Asserted to PD Valid	t18	0		nS
Command Deasserted to PD Hi-Z	t19	0		nS
$\overline{\text{WAIT}}$ Deasserted to PD Drive	t20	60	190	nS
$\overline{\text{WRITE}}$ Deasserted to Command	t21	1		nS
PBDIR Set to Command	t22	0	20	nS
PD Hi-Z to Command Asserted	t23	0	30	nS
Asserted to Command Asserted	t24	0	195	nS
$\overline{\text{WAIT}}$ Deasserted to Command Deasserted	t25	60	180	nS
Time out	t26	10	12	nS
PD Valid to $\overline{\text{WAIT}}$ Deasserted	t27	0		nS
PD Hi-Z to $\overline{\text{WAIT}}$ Deasserted	t28	0		μS
PARAMETER	SYM.	MIN.	MAX.	UNIT
Ax Valid to $\overline{\text{IOR}}$ Asserted	t1	40		nS
IOCHRDY Deasserted to $\overline{\text{IOR}}$ Deasserted	t2	0		nS
$\overline{\text{IOR}}$ Deasserted to Ax Valid	t3	10	10	nS
$\overline{\text{IOR}}$ Deasserted to $\overline{\text{IOW}}$ or $\overline{\text{IOR}}$ Asserted	t4	40		
$\overline{\text{IOR}}$ Asserted to IOCHRDY Asserted	t5	0	24	nS
PD Valid to SD Valid	t6	0	75	nS
$\overline{\text{IOR}}$ Deasserted to SD Hi-Z (Hold Time)	t7	0	40	μS
SD Valid to IOCHRDY Deasserted	t8	0	85	nS
$\overline{\text{WAIT}}$ Deasserted to IOCHRDY Deasserted	t9	60	160	nS
PD Hi-Z to PDBIR Set	t10	0		nS
$\overline{\text{WRITE}}$ Deasserted to $\overline{\text{IOR}}$ Asserted	t13	0		nS
$\overline{\text{WAIT}}$ Asserted to $\overline{\text{WRITE}}$ Deasserted	t14	0	185	nS
Deasserted to $\overline{\text{WRITE}}$ Modified	t15	60	190	nS
$\overline{\text{IOR}}$ Asserted to PD Hi-Z	t16	0	50	nS
$\overline{\text{WAIT}}$ Asserted to PD Hi-Z	t17	60	180	nS
Command Asserted to PD Valid	t18	0		nS
Command Deasserted to PD Hi-Z	t19	0		nS



PARAMETER	SYM.	MIN.	MAX.	UNIT
$\overline{\text{WAIT}}$ Deasserted to PD Drive	t20	60	190	nS
$\overline{\text{WRITE}}$ Deasserted to Command	t21	1		nS
PBDIR Set to Command	t22	0	20	nS
PD Hi-Z to Command Asserted	t23	0	30	nS
Asserted to Command Asserted	t24	0	195	nS
$\overline{\text{WAIT}}$ Deasserted to Command Deasserted	t25	60	180	nS
Time out	t26	10	12	nS
PD Valid to $\overline{\text{WAIT}}$ Deasserted	t27	0		nS
PD Hi-Z to $\overline{\text{WAIT}}$ Deasserted	t28	0		μS

25.9.3 EPP Data or Address Read Cycle (EPP Version 1.9)

EPP Data or Address Read Cycle (EPP Version 1.9)

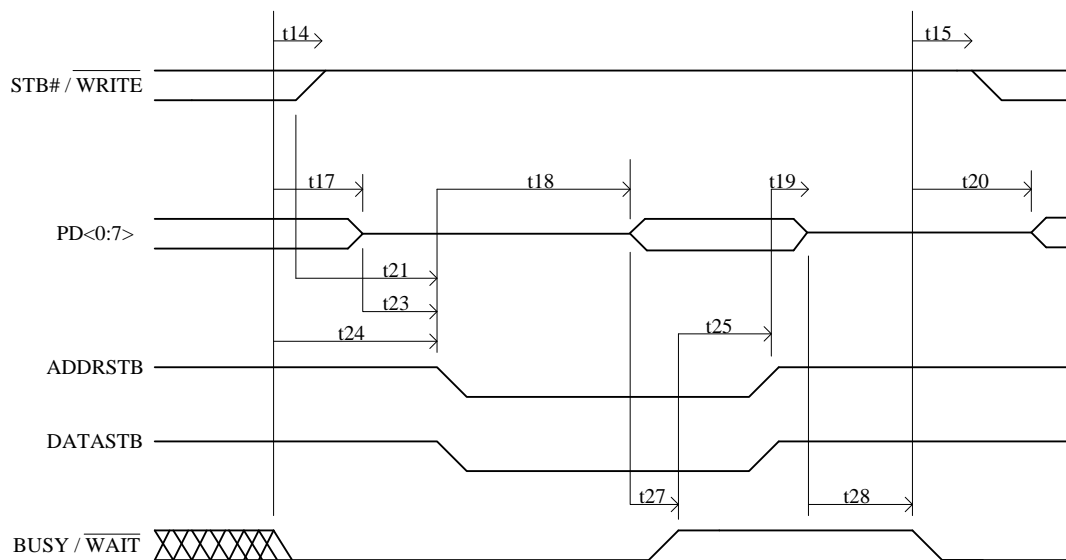

25.9.4 EPP Data or Address Read Cycle (EPP Version 1.7)

EPP Data or Address Read Cycle (EPP Version 1.7)

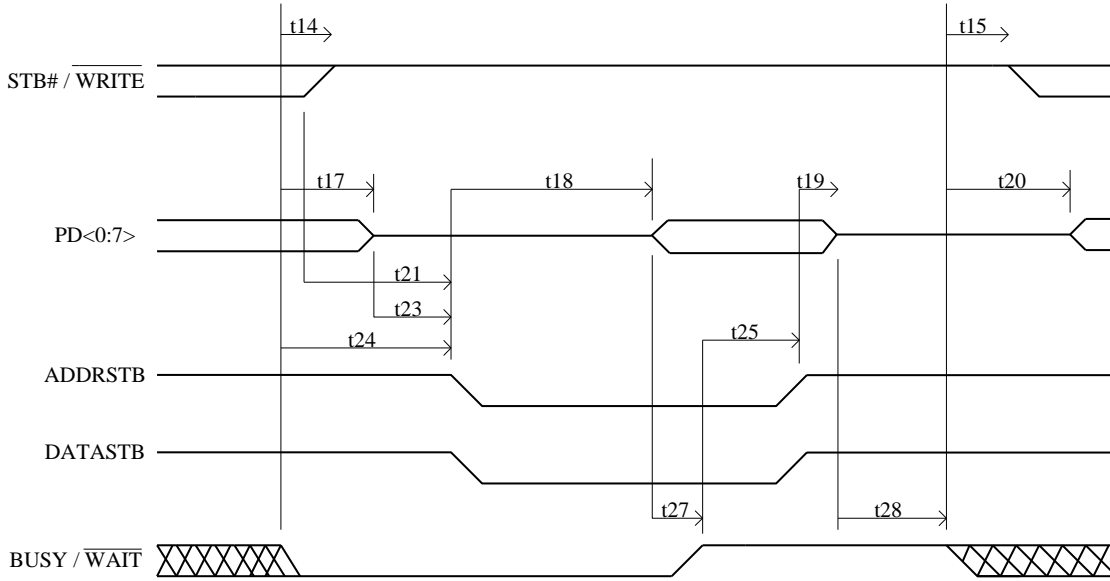

25.9.5 EPP Data or Address Write Cycle Timing Parameters

PARAMETER	SYM.	MIN.	MAX.	UNIT
PBDIR Low to $\overline{\text{WRITE}}$ Asserted	t10	0		nS
$\overline{\text{WAIT}}$ Asserted to $\overline{\text{WRITE}}$ Asserted	t11	60	185	nS
$\overline{\text{WAIT}}$ Asserted to $\overline{\text{WRITE}}$ Change	t12	60	185	nS
$\overline{\text{WAIT}}$ Asserted to PD Invalid	t14	0		nS
PD Invalid to Command Asserted	t15	10		nS
$\overline{\text{WAIT}}$ Asserted to Command Asserted	t17	60	210	nS
$\overline{\text{WAIT}}$ Deasserted to Command Deasserted	t18	60	190	nS
Command Asserted to $\overline{\text{WAIT}}$ Deasserted	t19	0	10	μS
Time out	t20	10	12	μS
Command Deasserted to $\overline{\text{WAIT}}$ Asserted	t21	0		nS
PARAMETER	SYM.	MIN.	MAX.	UNIT
Ax Valid to $\overline{\text{IOW}}$ Asserted	t1	40		nS
SD Valid to Asserted	t2	10		nS
$\overline{\text{IOW}}$ Deasserted to Ax Invalid	t3	10		nS
$\overline{\text{WAIT}}$ Deasserted to IOCHRDY Deasserted	t4	0		nS
Command Asserted to $\overline{\text{WAIT}}$ Deasserted	t5	10		nS
$\overline{\text{IOW}}$ Deasserted to $\overline{\text{IOW}}$ or $\overline{\text{IOR}}$ Asserted	t6	40		nS
IOCHRDY Deasserted to $\overline{\text{IOW}}$ Deasserted	t7	0	24	nS
$\overline{\text{WAIT}}$ Asserted to Command Asserted	t8	60	160	nS
$\overline{\text{IOW}}$ Asserted to $\overline{\text{WAIT}}$ Asserted	t9	0	70	nS
PBDIR Low to $\overline{\text{WRITE}}$ Asserted	t10	0		nS
$\overline{\text{WAIT}}$ Asserted to $\overline{\text{WRITE}}$ Asserted	t11	60	185	nS
$\overline{\text{WAIT}}$ Asserted to $\overline{\text{WRITE}}$ Change	t12	60	185	nS
$\overline{\text{IOW}}$ Asserted to PD Valid	t13	0	50	nS
$\overline{\text{WAIT}}$ Asserted to PD Invalid	t14	0		nS
PD Invalid to Command Asserted	t15	10		nS
$\overline{\text{IOW}}$ to Command Asserted	t16	5	35	nS
$\overline{\text{WAIT}}$ Asserted to Command Asserted	t17	60	210	nS
$\overline{\text{WAIT}}$ Deasserted to Command Deasserted	t18	60	190	nS
Command Asserted to $\overline{\text{WAIT}}$ Deasserted	t19	0	10	μS
Time out	t20	10	12	μS
Command Deasserted to $\overline{\text{WAIT}}$ Asserted	t21	0		nS
$\overline{\text{IOW}}$ Deasserted to $\overline{\text{WRITE}}$ Deasserted and PD invalid	t22	0		nS
$\overline{\text{WRITE}}$ to Command Asserted	t16	5	35	nS

25.9.6 EPP Data or Address Write Cycle (EPP Version 1.9)

EPP Data or Address Write Cycle (EPP Version 1.9)

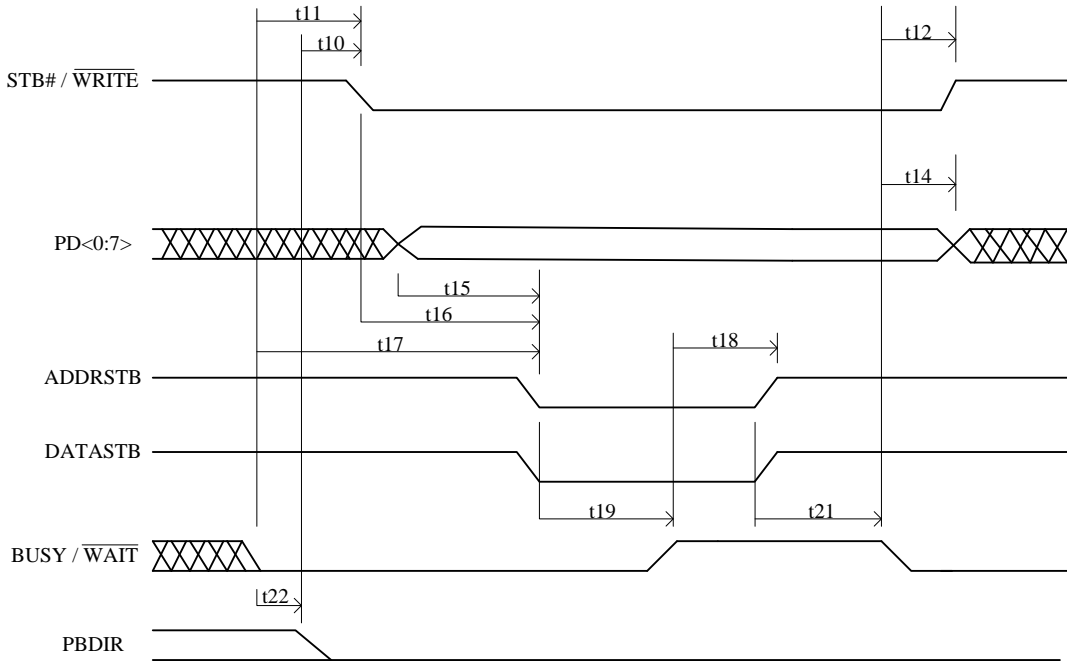

25.9.7 EPP Data or Address Write Cycle (EPP Version 1.7)

EPP Data or Address Write Cycle (EPP Version 1.7)

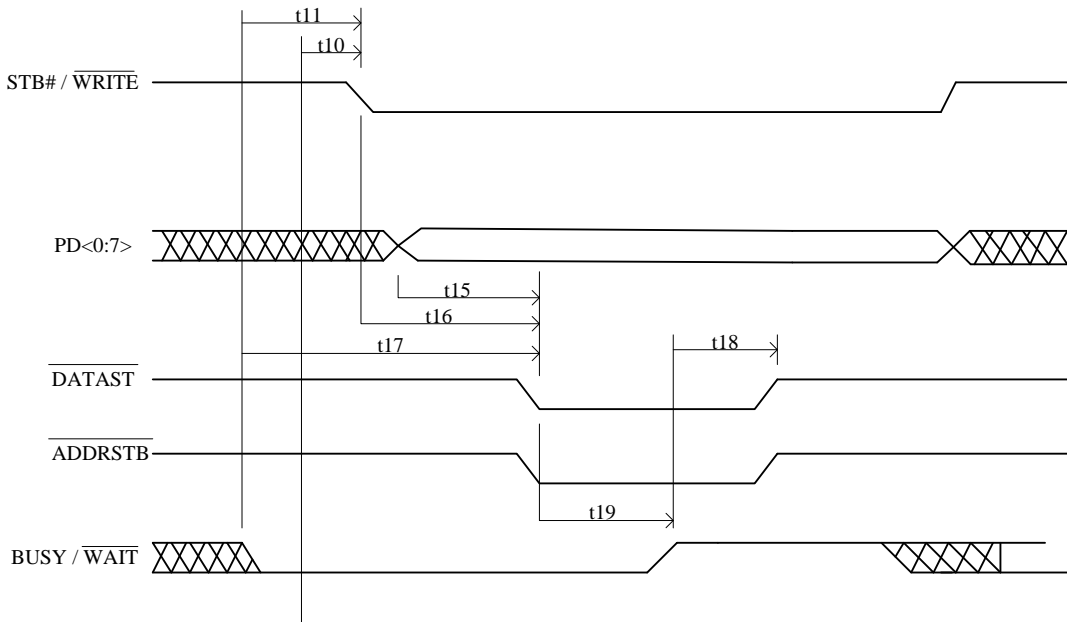

25.9.8 Parallel Port FIFO Timing Parameters

PARAMETER	SYMBOL	MIN.	MAX.	UNIT
DATA Valid to nSTROBE Active	t1	600		nS
nSTROBE Active Pulse Width	t2	600		nS
DATA Hold from nSTROBE Inactive	t3	450		nS
BUSY Inactive to PD Inactive	t4	80		nS
BUSY Inactive to nSTROBE Active	t5	680		nS
nSTROBE Active to BUSY Active	t6		500	nS

25.9.9 Parallel FIFO Timing

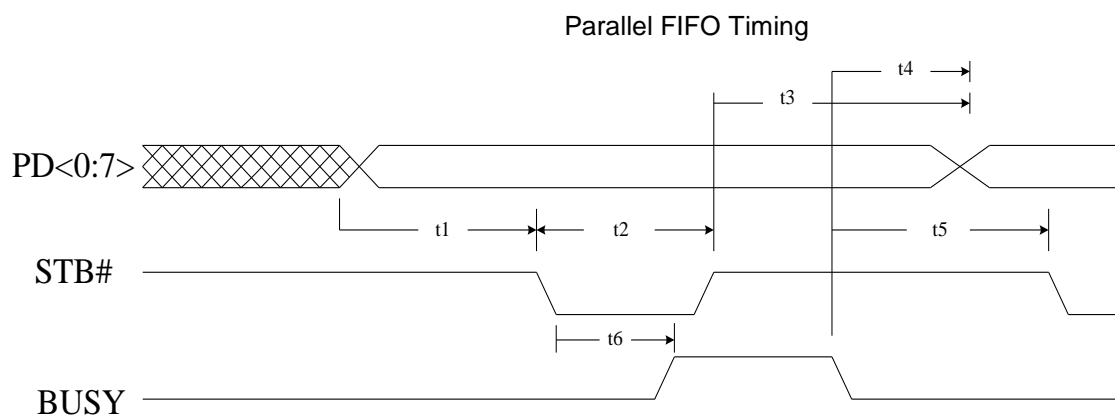

25.9.10ECP Parallel Port Forward Timing Parameters

PARAMETER	SYMBOL	MIN.	MAX.	UNIT
nAUTOFD Valid to nSTROBE Asserted	t1	0	60	nS
PD Valid to nSTROBE Asserted	t2	0	60	nS
BUSY Deasserted to nAUTOFD Changed	t3	80	180	nS
BUSY Deasserted to PD Changed	t4	80	180	nS
nSTROBE Deasserted to BUSY Deasserted	t5	0		nS
BUSY Deasserted to nSTROBE Asserted	t6	80	200	nS
nSTROBE Asserted to BUSY Asserted	t7	0		nS
BUSY Asserted to nSTROBE Deasserted	t8	80	180	nS

25.9.11 ECP Parallel Port Forward Timing

ECP Parallel Port Forward Timing

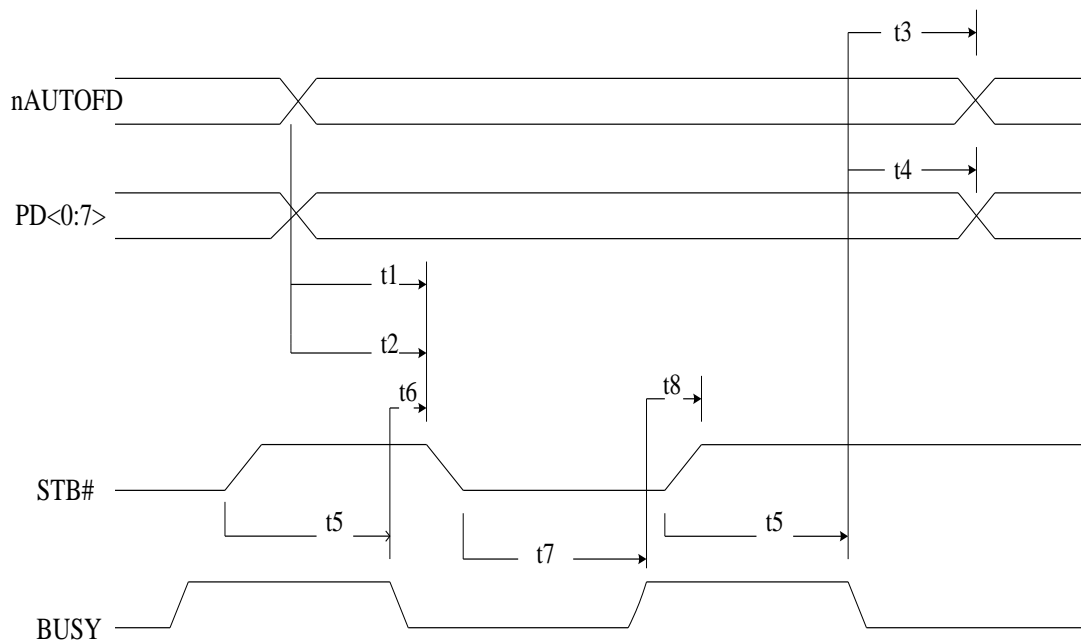

25.9.12 ECP Parallel Port Reverse Timing Parameters

PARAMETER	SYMBOL	MIN.	MAX.	UNIT
PD Valid to nACK Asserted	t1	0		nS
nAUTOFD Deasserted to PD Changed	t2	0		nS
nAUTOFD Asserted to nACK Asserted	t3	0		nS
nAUTOFD Deasserted to nACK Deasserted	t4	0		nS
nACK Deasserted to nAUTOFD Asserted	t5	80	200	nS
PD Changed to nAUTOFD Deasserted	t6	80	200	nS

25.9.13 ECP Parallel Port Reverse Timing

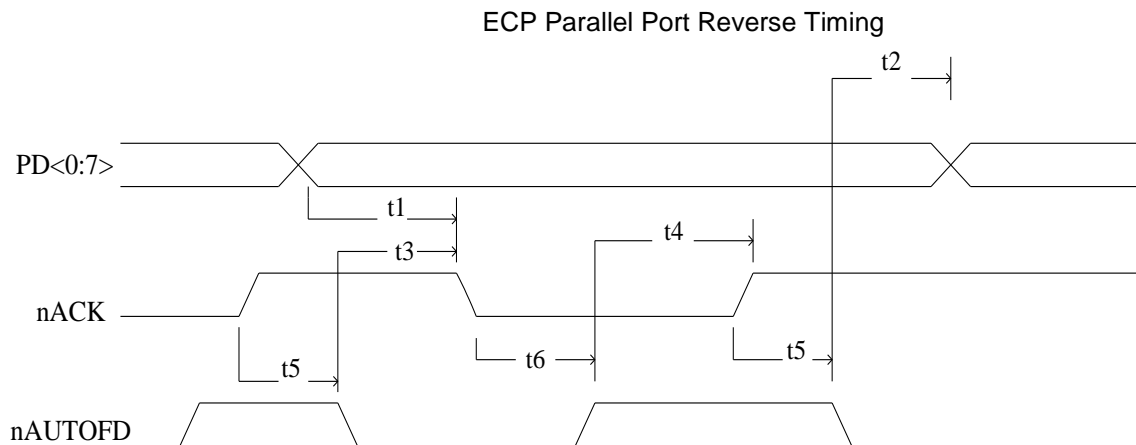

25.9.14 KBC Timing Parameters

NO.	DESCRIPTION	MIN.	MAX.	UNIT
T1	Address Setup Time from WRB	0		nS
T2	Address Setup Time from RDB	0		nS
T3	WRB Strobe Width	20		nS
T4	RDB Strobe Width	20		nS
T5	Address Hold Time from WRB	0		nS
T6	Address Hold Time from RDB	0		nS
T7	Data Setup Time	50		nS
T8	Data Hold Time	0		nS
T9	Gate Delay Time from WRB	10	30	nS
T10	RDB to Drive Data Delay		40	nS
T11	RDB to Floating Data Delay	0	20	nS
T12	Data Valid After Clock Falling (SEND)		4	μ S
T13	K/B Clock Period	20		μ S
T14	K/B Clock Pulse Width	10		μ S
T15	Data Valid Before Clock Falling (RECEIVE)	4		μ S
T16	K/B ACK After Finish Receiving	20		μ S
T19	Transmit Timeout		2	mS
T20	Data Valid Hold Time	0		μ S

NO.	DESCRIPTION	MIN.	MAX.	UNIT
T21	Input Clock Period (6–16 Mhz)	63	167	nS
T22	Duration of CLK inactive	30	50	μS
T23	Duration of CLK active	30	50	μS
T24	Time from inactive CLK transition, used to time when the auxiliary device sample DATA	5	25	μS
T25	Time of inhibit mode	100	300	μS
T26	Time from rising edge of CLK to DATA transition	5	T28-5	μS
T27	Duration of CLK inactive	30	50	μS
T28	Duration of CLK active	30	50	μS
T29	Time from DATA transition to falling edge of CLK	5	25	μS

25.9.15 Writing Cycle Timing

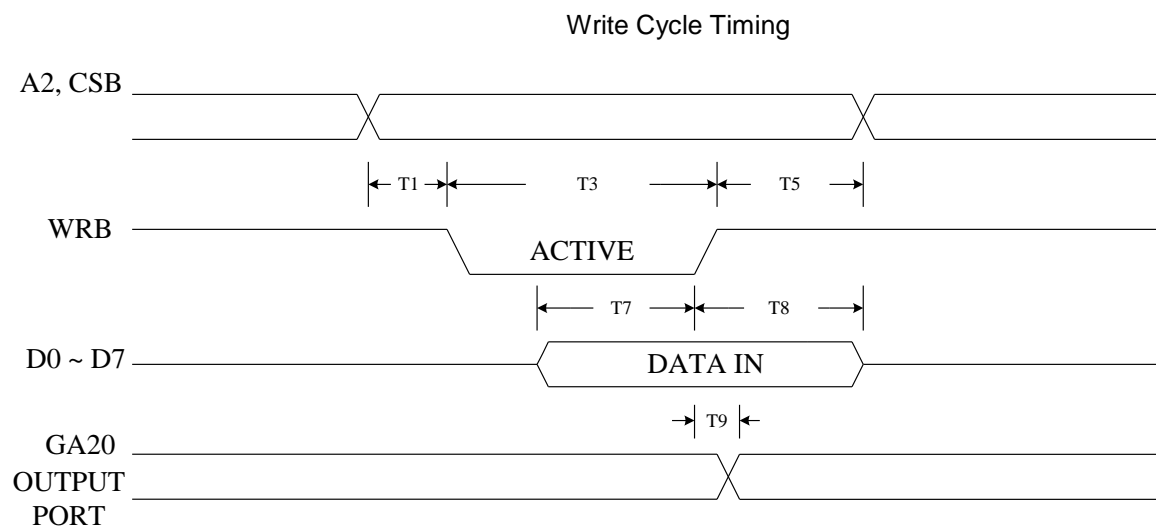

25.9.16 Read Cycle Timing

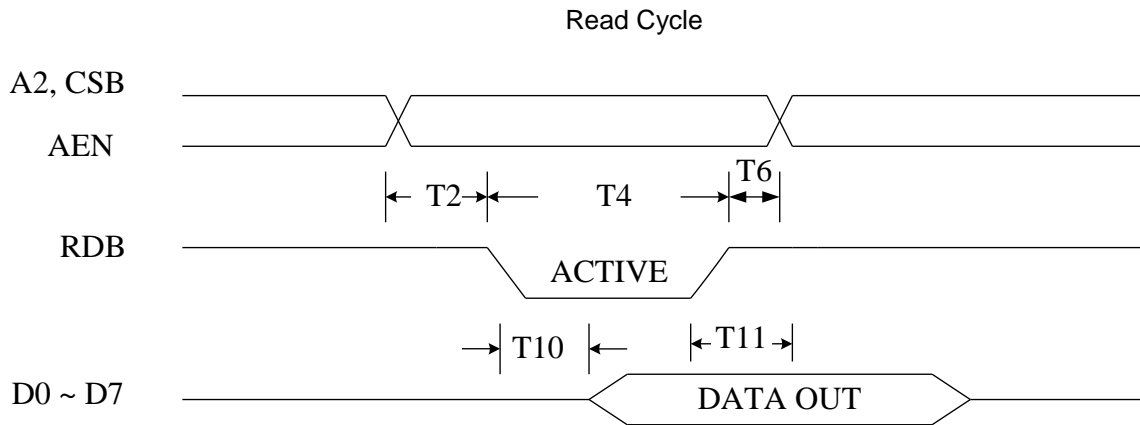

25.9.17 Send Data to K/B

Send Data to K/B

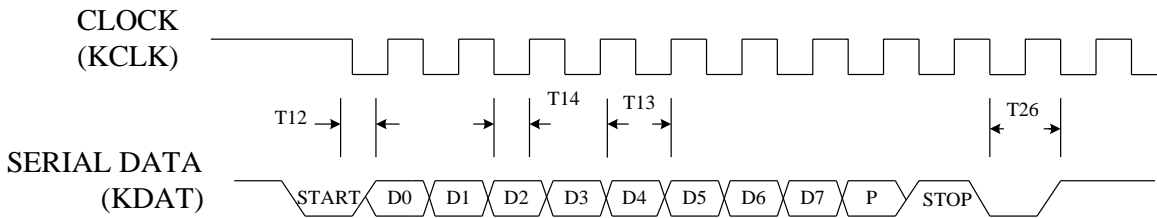

25.9.18 Receive Data from K/B

Receive Data from K/B

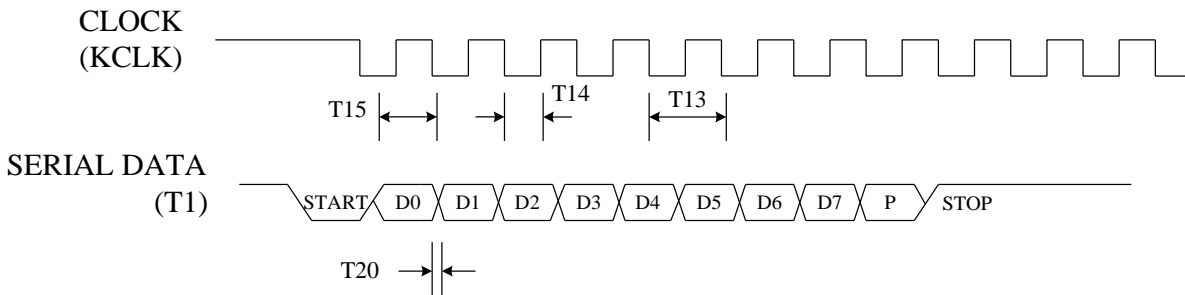

25.9.19 Input Clock

Input Clock

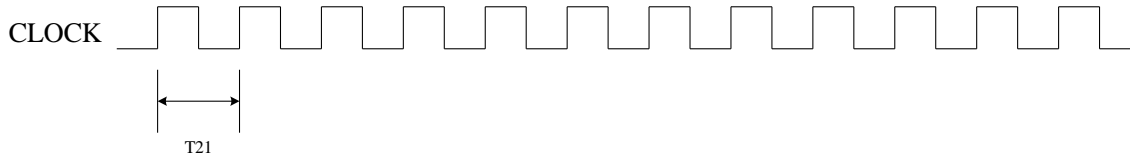

25.9.20 Send Data to Mouse

Send Data to Mouse

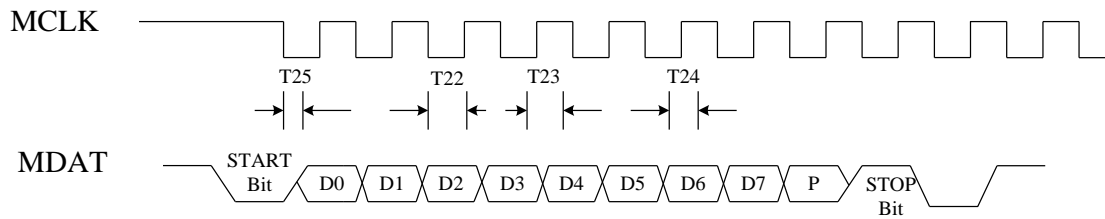

25.9.21 Receive Data from Mouse

Receive Data from Mouse

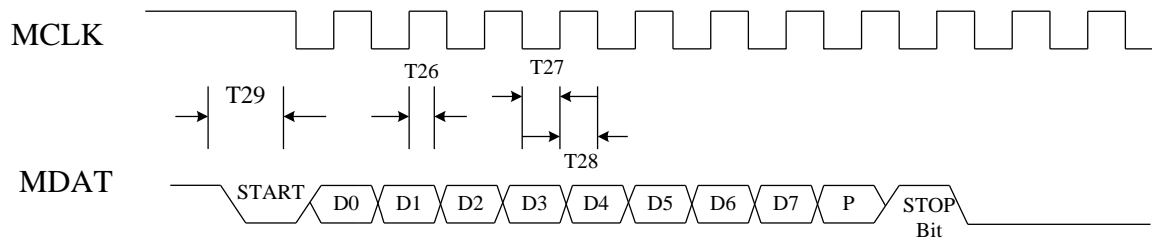

25.10 GPIO Timing Parameters

SYMBOL	PARAMETER	MIN.	MAX.	UNIT
t _{WGO}	Write data to GPIO update		300(Note 1)	ns
t _{SWP}	SWITCH pulse width	16		msec

Note: Refer to Microprocessor Interface Timing for Read Timing.

25.10.1 GPIO Write Timing

GPIO Write Timing diagram

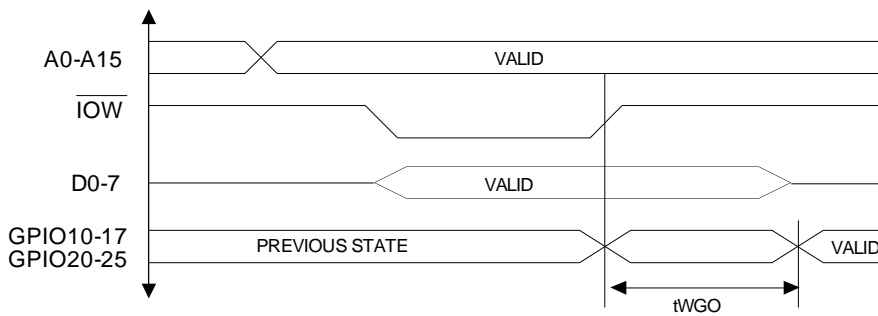

26. TOP MARKING SPECIFICATIONS



1st line: Nuvoton logo

2nd line: part number **NCT6102D**

3rd line: wafer production series lot number 28201234

4th line: tracking code 206G9BFA

206: packages made in 2012, week 06

G: assembly house ID; G means GR, A means ASE, etc

9: code version; 9 means code 009

B: IC revision; A means version A; B means version B, and C means version C

FA: Nuvoton internal use



1st line: Nuvoton logo

2nd line: part number **NCT6106D**

3rd line: wafer production series lot number 28201234

4th line: tracking code 206G9BFA

206: packages made in 2012, week 06

G: assembly house ID; G means GR, A means ASE, etc

9: code version; 9 means code 009

B: IC revision; A means version A; B means version B, and C means version C

FA: Nuvoton internal use

27. ORDERING INFORMATION

PART NUMBER	PACKAGE TYPE	PRODUCTION FLOW
NCT6102D	128Pin LQFP (Green package)	-40°C ~+85°C
NCT6106D	128Pin LQFP (Green package)	-40°C ~+85°C

28. PACKAGE SPECIFICATION

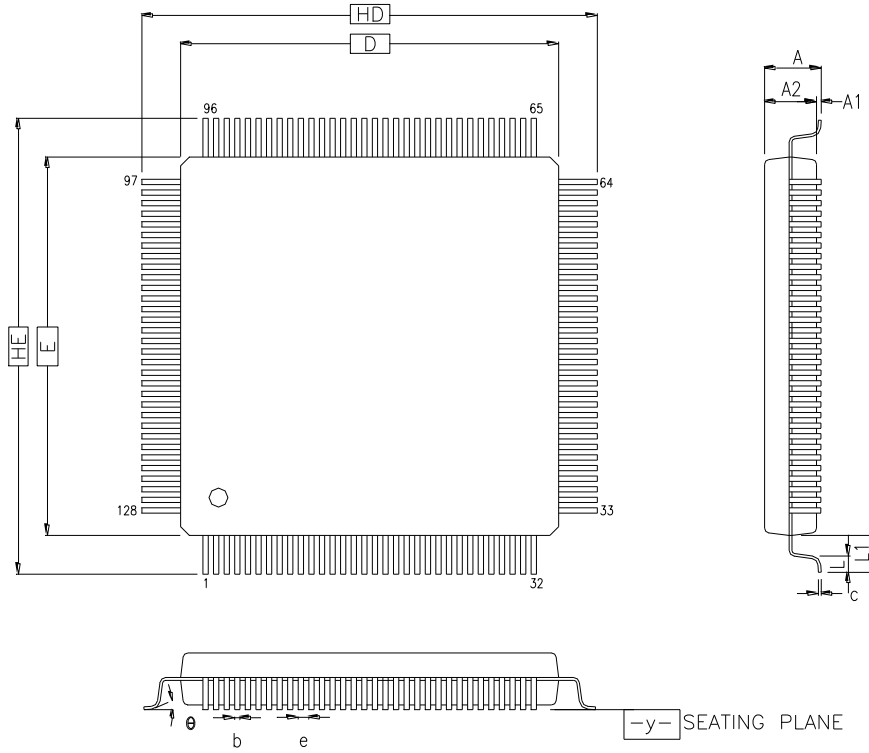

COTROL DIMENSIONS ARE IN MILLIMETERS.

SYMBOL	MILLIMETER			INCH		
	MIN.	NOM.	MAX.	MIN.	NOM.	MAX.
A	—	—	1.60	—	—	0.063
A1	0.05	—	0.15	0.002	—	0.006
A2	1.35	1.40	1.45	0.053	0.055	0.057
HD	16.00 BSC.			0.630 BSC.		
D	14.00 BSC.			0.551 BSC.		
HE	16.00 BSC.			0.630 BSC.		
E	14.00 BSC.			0.551 BSC.		
b	0.13	0.16	0.23	0.005	0.006	0.009
e	0.40 BSC.			0.016 BSC.		
θ	0°	3.5°	7°	0°	3.5°	7°
c	0.09	—	0.20	0.004	—	0.008
L	0.45	0.60	0.75	0.018	0.024	0.030
L ₁	1.00 REF			0.039 REF		
y	—	—	0.1	—	—	0.004

128-pin LQFP (14x14x1.4mm)

29. REVISION HISTORY

VERSION	DATE	PAGE	DESCRIPTION
0.1	08/03/2010	N.A.	Draft datasheet
0.5	06/27/2011	N.A.	Preliminary datasheet
0.6	09/29/2011	N.A.	Move PCHVSB from pin #78 to pin #69
1.0	01/11/2012	N.A.	Add part number NCT6102D Update GPIO7 description

Important Notice

Nuvoton Products are neither intended nor warranted for usage in systems or equipment, any malfunction or failure of which may cause loss of human life, bodily injury or severe property damage. Such applications are deemed, "Insecure Usage".

Insecure usage includes, but is not limited to: equipment for surgical implementation, atomic energy control instruments, airplane or spaceship instruments, the control or operation of dynamic, brake or safety systems designed for vehicular use, traffic signal instruments, all types of safety devices, and other applications intended to support or sustain life.

All Insecure Usage shall be made at customer's risk, and in the event that third parties lay claims to Nuvoton as a result of customer's Insecure Usage, customer shall indemnify the damages and liabilities thus incurred by Nuvoton.

*Please note that all data and specifications are subject to change without notice.
All the trademarks of products and companies mentioned in this datasheet belong to their respective owners.*