

NCV4279B

5.0 V Micropower 150 mA LDO Linear Regulator with DELAY, Adjustable RESET, and Monitor FLAG

The NCV4279B is a 5.0 V precision micropower voltage regulator. The output current capability is 150 mA.

The output voltage is accurate within $\pm 2.0\%$ with a maximum dropout voltage of 0.6 V at 150 mA. Low quiescent current is a feature drawing only 90 μA with a 100 μA load. This part is ideal for any and all battery operated microprocessor equipment.

Microprocessor control logic includes an active $\overline{\text{RESET}}$ (with DELAY), and a FLAG monitor which can be used to provide an early warning signal to the microprocessor of a potential impending $\overline{\text{RESET}}$ signal. The use of the FLAG monitor allows the microprocessor to finish any signal processing before the $\overline{\text{RESET}}$ shuts the microprocessor down.

The active $\overline{\text{RESET}}$ circuit operates correctly at an output voltage as low as 1.0 V. The $\overline{\text{RESET}}$ function is activated during the power up sequence or during normal operation if the output voltage drops outside the regulation limits.

The reset threshold voltage can be decreased by the connection of external resistor divider to R_{ADJ} lead.

The regulator is protected against reverse battery, short circuit, and thermal overload conditions. The device can withstand load dump transients making it suitable for use in automotive environments. The device has also been optimized for EMC conditions.

Features

- 5.0 V $\pm 2.0\%$ Output
- Low 90 μA Quiescent Current
- Active $\overline{\text{RESET}}$
- Adjustable Reset
- 150 mA Output Current Capability
- Fault Protection
 - +60 V Peak Transient Voltage
 - -15 V Reverse Voltage
 - Short Circuit
 - Thermal Overload
- Early Warning through $\overline{\text{FLAG}}/\text{MON}$ Leads
- Internally Fused Leads in SO-14 and SO-20L Packages
- NCV Prefix for Automotive and Other Applications Requiring Site and Control Changes



ON Semiconductor®

<http://onsemi.com>

MARKING DIAGRAMS

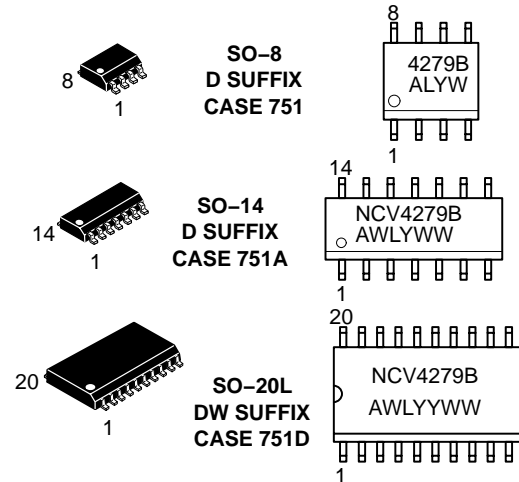

A = Assembly Location
 WL, L = Wafer Lot
 YY, Y = Year
 WW, W = Work Week

PIN CONNECTIONS

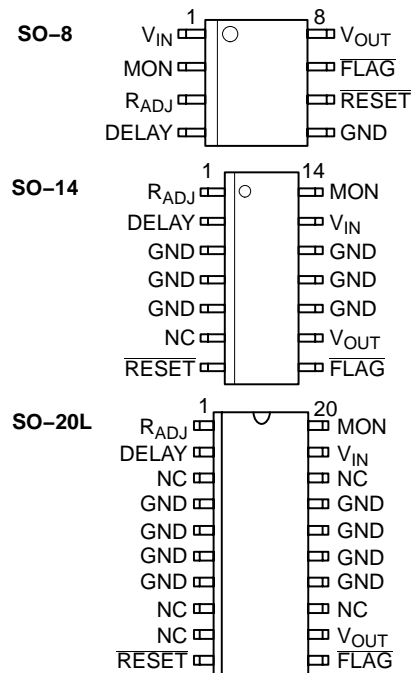

ORDERING INFORMATION

See detailed ordering and shipping information in the package dimensions section on page 10 of this data sheet.

NCV4279B

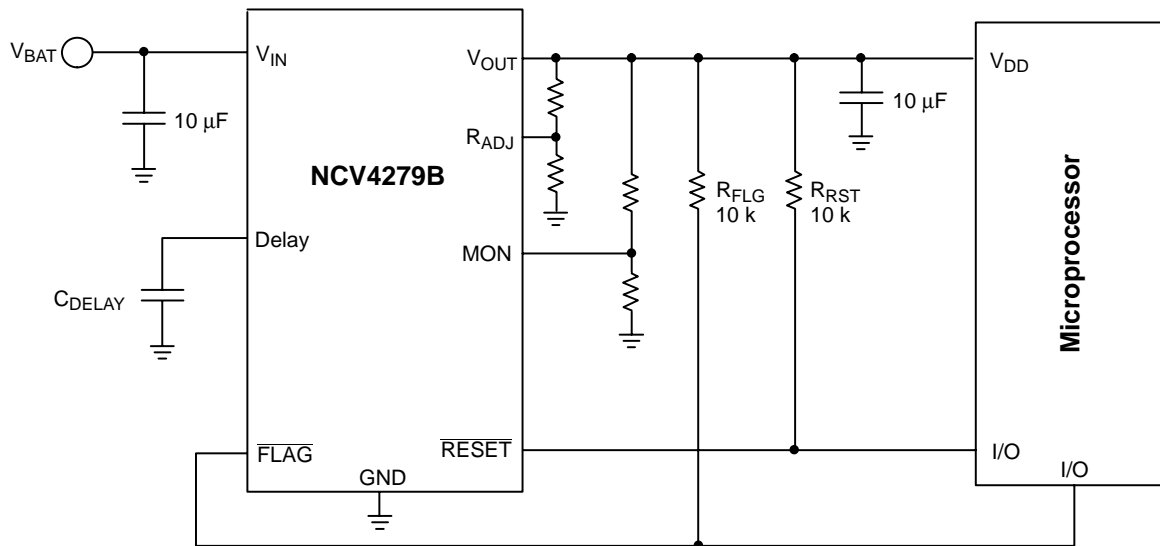

Figure 1. Application Diagram

MAXIMUM RATINGS*†

Rating	Value	Unit
V _{IN} (DC)	-15 to 45	V
Peak Transient Voltage (46 V Load Dump @ V _{IN} = 14 V)	60	V
Operating Voltage	45	V
V _{OUT} (DC)	16	V
Voltage Range (RESET, FLAG)	-0.3 to 10	V
Input Voltage Range (MON)	-0.3 to 10	V
ESD Susceptibility (Human Body Model)	2.0	kV
Junction Temperature, T _J	-40 to +150	°C
Storage Temperature, T _S	-55 to 150	°C
Package Thermal Resistance, SO-8: Junction-to-Case, R _{θJC} Junction-to-Ambient, R _{θJA}	45 165	°C/W
Package Thermal Resistance, SO-14 (Fused) Minimum Pad Data: Junction-to-Case, R _{θJC} Junction-to-Ambient, R _{θJA} Junction-to-Pin, R _{θJP} (Note 3)	15 110 33	°C/W
Package Thermal Resistance, SO-20L (Fused) Minimum Pad Data: Junction-to-Case, R _{θJC} Junction-to-Ambient, R _{θJA} Junction-to-Pin, R _{θJP} (Note 4)	12 82 26	°C/W
Lead Temperature Soldering:	Reflow: (SMD styles only) (Notes 1, 2)	240 peak °C

1. 60 second maximum above 183°C.
2. -5°C/+0°C allowable conditions.
3. Measured to pin 9.
4. Measured to pin 12.

*The maximum package power dissipation must be observed.

†During the voltage range which exceeds the maximum tested voltage of V_{IN}, operation is assured, but not specified. Wider limits may apply. Thermal dissipation must be observed closely.

NCV4279B

ELECTRICAL CHARACTERISTICS ($I_{OUT} = 1.0 \text{ mA}$, $-40^{\circ}\text{C} \leq T_J \leq 125^{\circ}\text{C}$; $6.0 \text{ V} < V_{IN} < 26 \text{ V}$; unless otherwise specified.)

Characteristic	Test Conditions	Min	Typ	Max	Unit
Output Stage					
Output Voltage	$9.0 \text{ V} < V_{IN} < 16 \text{ V}$, $100 \mu\text{A} \leq I_{OUT} \leq 150 \text{ mA}$ $6.0 \text{ V} < V_{IN} < 26 \text{ V}$, $100 \mu\text{A} \leq I_{OUT} \leq 150 \text{ mA}$	4.90 4.85	5.0 5.0	5.10 5.15	V V
Dropout Voltage ($V_{IN} - V_{OUT}$)	$I_{OUT} = 150 \text{ mA}$ $I_{OUT} = 100 \mu\text{A}$	– –	400 100	600 150	mV mV
Load Regulation	$V_{IN} = 14 \text{ V}$, $5.0 \text{ mA} \leq I_{OUT} \leq 150 \text{ mA}$	-30	5.0	30	mV
Line Regulation	$[V_{OUT}(\text{typ}) + 1.0] < V_{IN} < 26 \text{ V}$, $I_{OUT} = 1.0 \text{ mA}$	–	15	60	mV
Quiescent Current, (I_Q) Active Mode	$I_{OUT} = 100 \mu\text{A}$, $V_{IN} = 12 \text{ V}$, Delay = 3.0 V, MON = 3.0 V $I_{OUT} = 75 \text{ mA}$, $V_{IN} = 14 \text{ V}$, Delay = 3.0 V, MON = 3.0 V $I_{OUT} \leq 150 \text{ mA}$, $V_{IN} = 14 \text{ V}$, Delay = 3.0 V, MON = 3.0 V	– – –	90 4.0 12	125 6.0 19	μA mA mA
Current Limit	–	151	300	–	mA
Short Circuit Output Current	$V_{OUT} = 0 \text{ V}$	40	190	–	mA
Thermal Shutdown	(Guaranteed by Design)	150	180	–	$^{\circ}\text{C}$

Reset Function (RESET)

RESET Threshold HIGH (V_{RH}) LOW (V_{RL})	V_{OUT} Increasing V_{OUT} Decreasing	4.55 4.50	4.70 4.60	$0.98 \times V_{OUT}$ $0.97 \times V_{OUT}$	V V
Output Voltage Low (V_{RLO})	$1.0 \text{ V} \leq V_{OUT} \leq V_{RL}$, $R_{RESET} = 10 \text{ k}$	–	0.1	0.4	V
Delay Switching Threshold (V_{DT})	–	1.4	1.8	2.2	V
Reset Delay Low Voltage	$V_{OUT} < \overline{\text{RESET}}$ Threshold Low(min)	–	–	0.1	V
Delay Charge Current	DELAY = 1.0 V, $V_{OUT} > V_{RH}$	1.5	2.5	3.5	μA
Delay Discharge Current	DELAY = 1.0 V, $V_{OUT} = 1.5 \text{ V}$	5.0	–	–	mA
Reset Adjust Switching Voltage ($V_{R(ADJ)}$)	–	1.23	1.31	1.39	V

FLAG/Monitor

Monitor Threshold	Increasing and Decreasing	1.10	1.20	1.31	V
Hysteresis	–	20	50	100	mV
Input Current	MON = 2.0 V	-0.5	0.1	0.5	μA
Output Saturation Voltage	MON = 0 V, $I_{FLAG} = 1.0 \text{ mA}$	–	0.1	0.4	V

PACKAGE PIN DESCRIPTION

Package Pin Number			Pin Symbol	Function
SO-8	SO-14	SO-20L		
3	1	1	R _{ADJ}	Reset Adjust. If not needed connect to ground.
4	2	2	DELAY	Timing capacitor for $\overline{\text{RESET}}$ function.
5	3-5, 10-12	4-7, 14-17	GND	Ground. All GND leads must be connected to Ground.
-	6	3, 8, 9, 13, 18	NC	No connection.
6	7	10	$\overline{\text{RESET}}$	Active reset (accurate to $V_{\text{OUT}} \geq 1.0 \text{ V}$)
7	8	11	FLAG	Open collector output from early warning comparator.
8	9	12	V _{OUT}	$\pm 2.0\%$, 150 mA output.
1	13	19	V _{IN}	Input Voltage.
2	14	20	MON	Monitor. Input for early warning comparator. If not needed connect to V _{OUT} .

TYPICAL PERFORMANCE CHARACTERISTICS

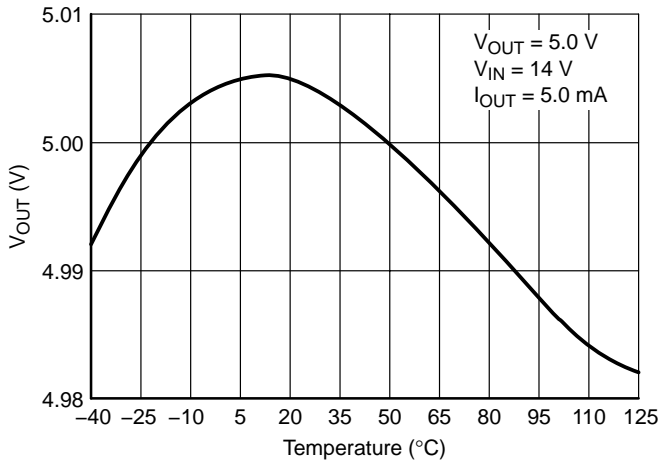

Figure 2. Output Voltage vs. Temperature

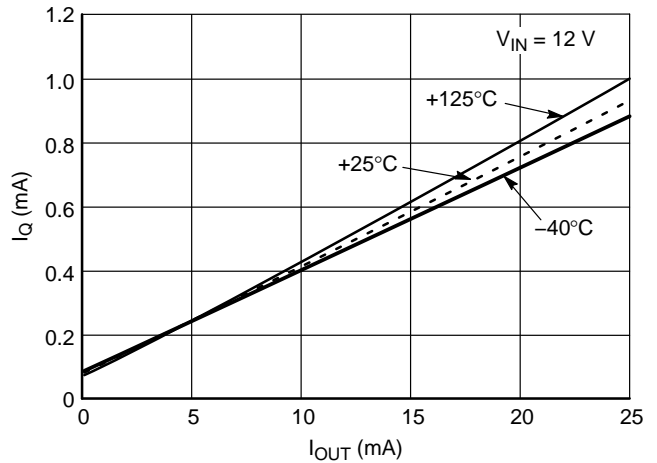

Figure 3. Quiescent Current vs. Output Current

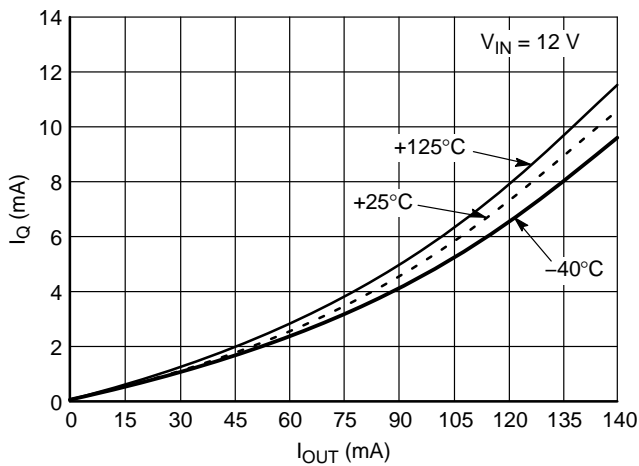

Figure 4. Quiescent Current vs. Output Current

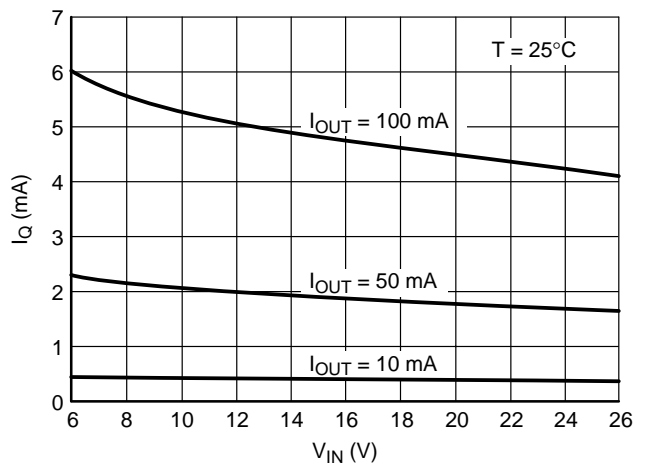

Figure 5. Quiescent Current vs. Input Voltage

TYPICAL PERFORMANCE CHARACTERISTICS

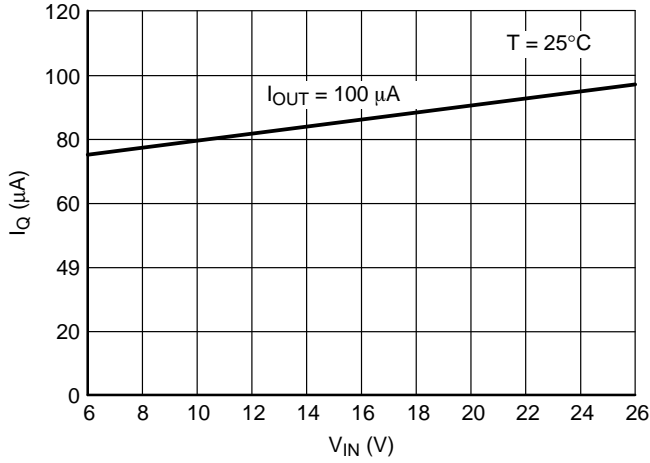

Figure 6. Quiescent Current vs. Input Voltage

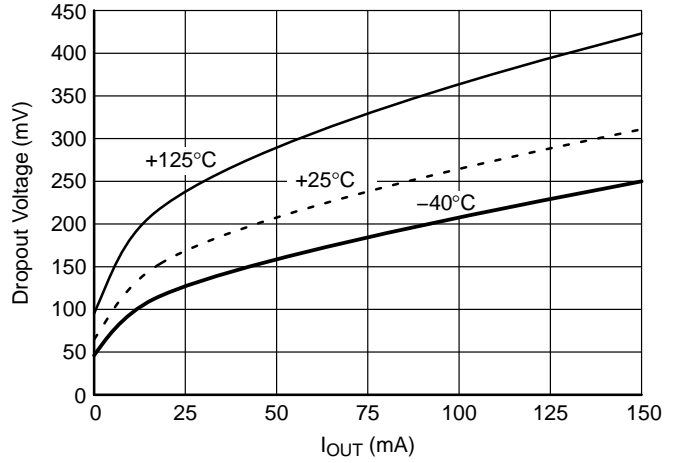

Figure 7. Dropout Voltage vs. Output Current

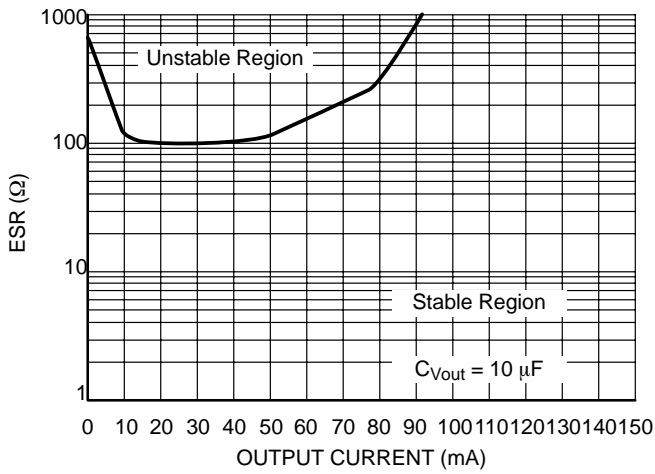

Figure 8. Output Capacitor ESR

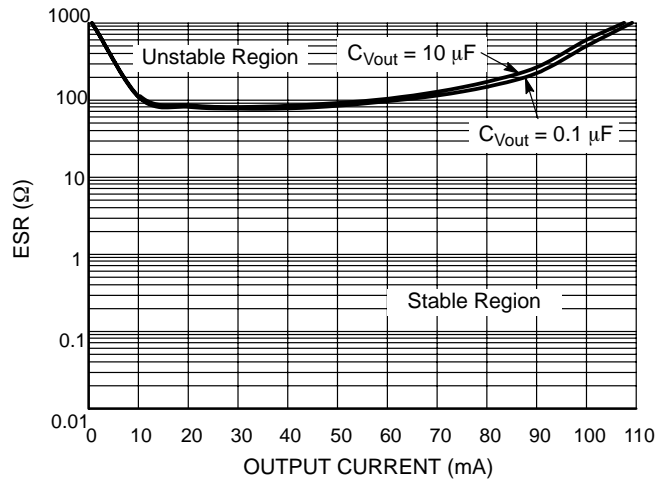

Figure 9. Output Stability with Output Capacitor Change

NCV4279B

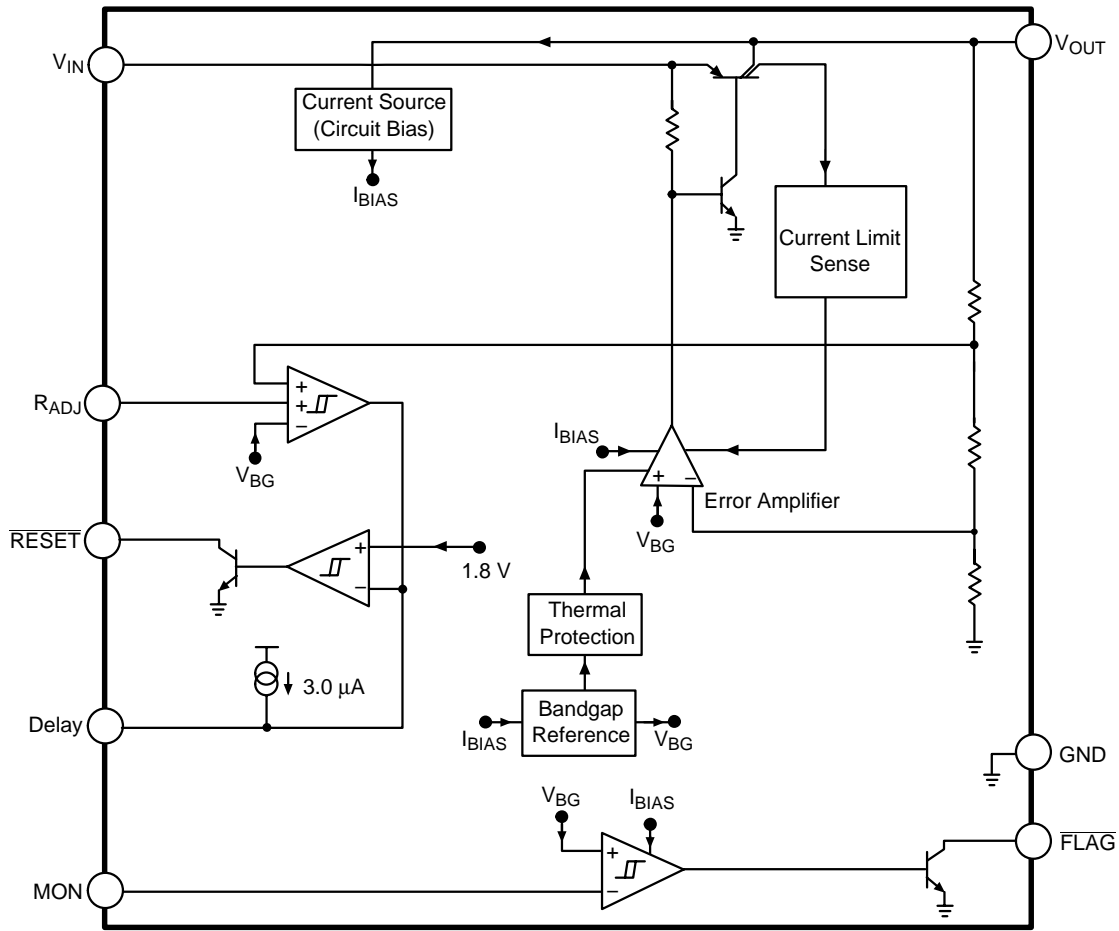

Figure 10. Block Diagram

CIRCUIT DESCRIPTION

REGULATOR CONTROL FUNCTIONS

The NCV4279B contains the microprocessor compatible control function $\overline{\text{RESET}}$ (Figure 11).

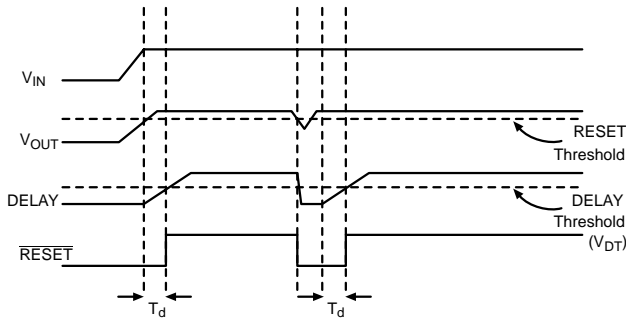

Figure 11. Reset and Delay Circuit Wave Forms

$\overline{\text{RESET}}$ Function

A $\overline{\text{RESET}}$ signal (low voltage) is generated as the IC powers up until V_{OUT} is within 6.0% of the regulated output voltage, or when V_{OUT} drops out of regulation, and is lower than 8.0% below the regulated output voltage. Hysteresis is included in the function to minimize oscillations.

The $\overline{\text{RESET}}$ output is an open collector NPN transistor, controlled by a low voltage detection circuit. The circuit is functionally independent of the rest of the IC thereby guaranteeing that the $\overline{\text{RESET}}$ signal is valid for V_{OUT} as low as 1.0 V.

Adjustable Reset Function

The reset threshold can be made lower by connecting an external resistor divider to the R_{ADJ} lead from the V_{OUT} lead, as displayed in Figure 12. This lead is grounded to select the default value of 4.6 V.

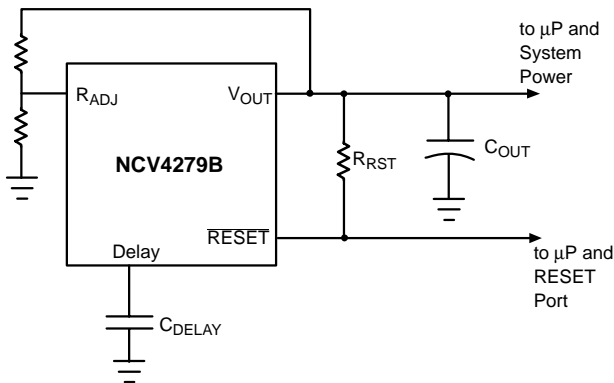

Figure 12. Adjustable $\overline{\text{RESET}}$

DELAY Function

The reset delay circuit provides a programmable (by external capacitor) delay on the $\overline{\text{RESET}}$ output lead.

The DELAY lead provides source current (typically $2.5 \mu\text{A}$) to the external DELAY capacitor during the following proceedings:

1. During Power Up (once the regulation threshold has been verified).
2. After a reset event has occurred and the device is back in regulation. The DELAY capacitor is discharged when the regulation ($\overline{\text{RESET}}$ threshold) has been violated. This is a latched incident. The capacitor will fully discharge and wait for the device to regulate before going through the delay time event again.

FLAG/Monitor Function

An on-chip comparator is provided to perform an early warning to the microprocessor of a possible reset signal. The reset signal typically turns the microprocessor off instantaneously. This can cause unpredictable results with the microprocessor. The signal received from the $\overline{\text{FLAG}}$ pin will allow the microprocessor time to complete its present task before shutting down. This function is performed by a comparator referenced to the bandgap reference. The actual trip point can be programmed externally using a resistor divider to the input monitor (MON) (Figure 13). The typical threshold is 1.20 V on the MON Pin.

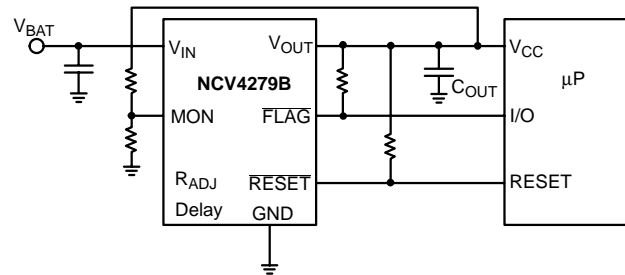

Figure 13. FLAG/Monitor Function

APPLICATION NOTES

FLAG MONITOR

Figure 14 shows the FLAG Monitor waveforms as a result of the circuit depicted in Figure 13. As the output voltage falls (V_{OUT}), the Monitor threshold is crossed. This causes the voltage on the \overline{FLAG} output to go low sending a warning signal to the microprocessor that a \overline{RESET} signal may occur in a short period of time. $T_{WARNING}$ is the time the microprocessor has to complete the function it is currently working on and get ready for the \overline{RESET} shutdown signal.

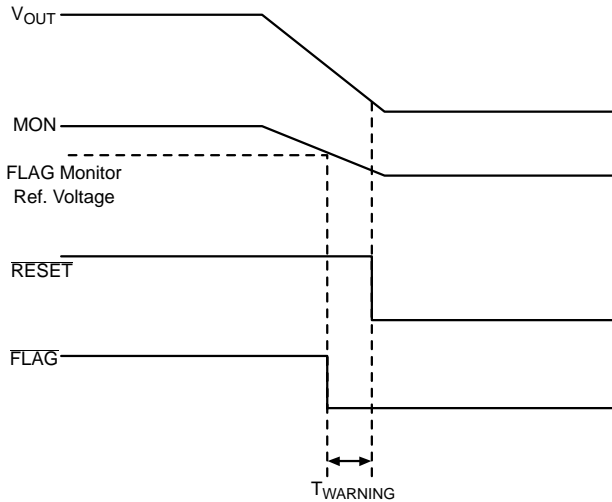

Figure 14. FLAG Monitor Circuit Waveform

SETTING THE DELAY TIME

The delay time is controlled by the Reset Delay Low Voltage, Delay Switching Threshold, and the Delay Charge Current. The delay follows the equation:

$$t_{DELAY} = \frac{[C_{DELAY}(V_{dt} - \text{Reset Delay Low Voltage})]}{\text{Delay Charge Current}}$$

Example:

Using $C_{DELAY} = 33 \text{ nF}$.

Assume reset Delay Low Voltage = 0.

Use the typical value for $V_{dt} = 1.8 \text{ V}$.

Use the typical value for Delay Charge Current = $2.5 \mu\text{A}$.

$$t_{DELAY} = \frac{[33 \text{ nF}(1.8 - 0)]}{2.5 \mu\text{A}} = 23.8 \text{ ms}$$

STABILITY CONSIDERATIONS

The output or compensation capacitor helps determine three main characteristics of a linear regulator: start-up delay, load transient response and loop stability.

The capacitor value and type should be based on cost, availability, size and temperature constraints. A tantalum or aluminum electrolytic capacitor is best, since a film or ceramic capacitor with almost zero ESR can cause instability. The aluminum electrolytic capacitor is the least expensive solution, but, if the circuit operates at low temperatures (-25°C to -40°C), both the value and ESR of the capacitor will vary considerably. The capacitor manufacturers data sheet usually provides this information.

The value for the output capacitor C_{OUT} shown in Figure 15 should work for most applications, however it is not necessarily the optimized solution.

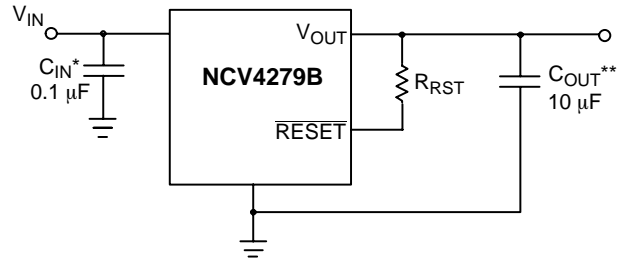

* C_{IN} required if regulator is located far from the power supply filter.
** C_{OUT} required for stability. Capacitor must operate at minimum temperature expected.

Figure 15. Test and Application Circuit Showing Output Compensation

CALCULATING POWER DISSIPATION IN A SINGLE OUTPUT LINEAR REGULATOR

The maximum power dissipation for a single output regulator (Figure 16) is:

$$P_{D(max)} = [V_{IN(max)} - V_{OUT(min)}]I_{OUT(max)} + V_{IN(max)}I_Q \quad (1)$$

where:

$V_{IN(max)}$ is the maximum input voltage,

$V_{OUT(min)}$ is the minimum output voltage,

$I_{OUT(max)}$ is the maximum output current for the application, and

I_Q is the quiescent current the regulator consumes at $I_{OUT(max)}$.

Once the value of $P_{D(max)}$ is known, the maximum permissible value of $R_{\theta JA}$ can be calculated:

$$R_{\theta JA} = \frac{150^{\circ}\text{C} - T_A}{P_D} \quad (2)$$

The value of $R_{\theta JA}$ can then be compared with those in the package section of the data sheet. Those packages with $R_{\theta JA}$'s less than the calculated value in equation 2 will keep the die temperature below 150°C .

In some cases, none of the packages will be sufficient to dissipate the heat generated by the IC, and an external heatsink will be required.

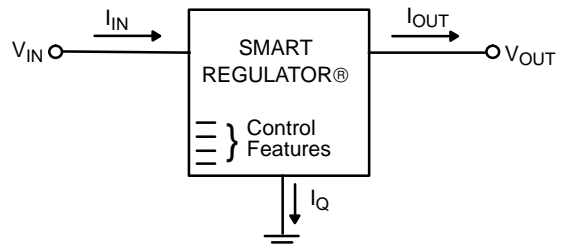

Figure 16. Single Output Regulator with Key Performance Parameters Labeled

HEAT SINKS

A heat sink effectively increases the surface area of the package to improve the flow of heat away from the IC and into the surrounding air.

Each material in the heat flow path between the IC and the outside environment will have a thermal resistance. Like series electrical resistances, these resistances are summed to determine the value of $R_{\theta JA}$:

$$R_{\theta JA} = R_{\theta JC} + R_{\theta CS} + R_{\theta SA} \quad (3)$$

where:

$R_{\theta JC}$ = the junction-to-case thermal resistance,
 $R_{\theta CS}$ = the case-to-heat sink thermal resistance, and
 $R_{\theta SA}$ = the heat sink-to-ambient thermal resistance.

$R_{\theta JC}$ appears in the package section of the data sheet. Like $R_{\theta JA}$, it too is a function of package type. $R_{\theta CS}$ and $R_{\theta SA}$ are functions of the package type, heat sink and the interface between them. These values appear in heat sink data sheets of heat sink manufacturers.

NCV4279B

ORDERING INFORMATION

Device	Output Voltage	Package	Shipping
NCV4279BD1	5.0 V	SO-8	98 Units/Rail
NCV4279BD1R2			2500 Tape & Reel
NCV4279BD2		SO-14	55 Units/Rail
NCV4279BD2R2			1000 Tape & Reel
NCV4279BDW		SO-20L	37 Units/Rail
NCV4279BDWR2			1000 Tape & Reel

NCV4279B

PACKAGE DIMENSIONS

SO-8
D SUFFIX
CASE 751-07
ISSUE AA

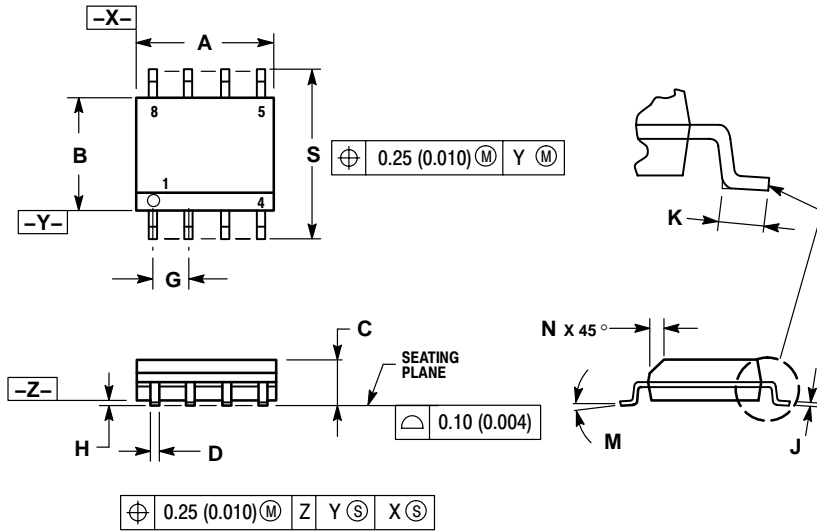

NOTES:

1. DIMENSIONING AND TOLERANCING PER ANSI Y14.5M, 1982.
2. CONTROLLING DIMENSION: MILLIMETER.
3. DIMENSION A AND B DO NOT INCLUDE MOLD PROTRUSION.
4. MAXIMUM MOLD PROTRUSION 0.15 (0.006) PER SIDE.
5. DIMENSION D DOES NOT INCLUDE DAMBAR PROTRUSION. ALLOWABLE DAMBAR PROTRUSION SHALL BE 0.127 (0.005) TOTAL IN EXCESS OF THE D DIMENSION AT MAXIMUM MATERIAL CONDITION.
6. 751-01 THRU 751-06 ARE OBSOLETE. NEW STANDARD IS 751-07

DIM	MILLIMETERS		INCHES	
	MIN	MAX	MIN	MAX
A	4.80	5.00	0.189	0.197
B	3.80	4.00	0.150	0.157
C	1.35	1.75	0.053	0.069
D	0.33	0.51	0.013	0.020
G	1.27 BSC		0.050 BSC	
H	0.10	0.25	0.004	0.010
J	0.19	0.25	0.007	0.010
K	0.40	1.27	0.016	0.050
M	0°	8°	0°	8°
N	0.25	0.50	0.010	0.020
S	5.80	6.20	0.228	0.244

SO-14
D SUFFIX
CASE 751A-03
ISSUE F

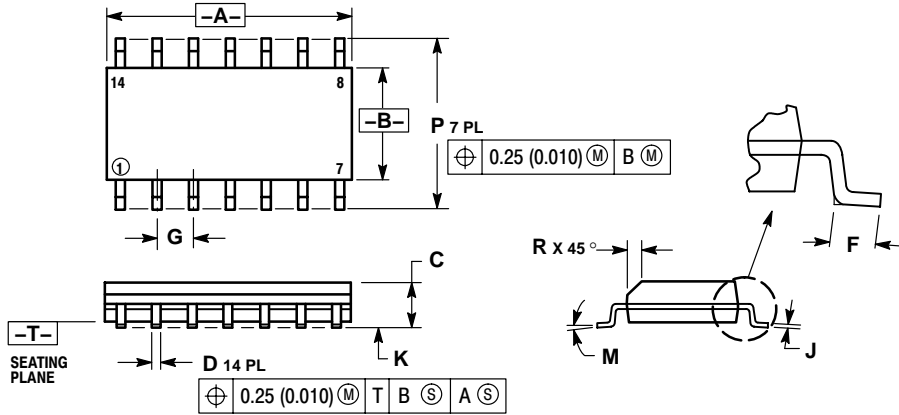

NOTES:

1. DIMENSIONING AND TOLERANCING PER ANSI Y14.5M, 1982.
2. CONTROLLING DIMENSION: MILLIMETER.
3. DIMENSIONS A AND B DO NOT INCLUDE MOLD PROTRUSION.
4. MAXIMUM MOLD PROTRUSION 0.15 (0.006) PER SIDE.
5. DIMENSION D DOES NOT INCLUDE DAMBAR PROTRUSION. ALLOWABLE DAMBAR PROTRUSION SHALL BE 0.127 (0.005) TOTAL IN EXCESS OF THE D DIMENSION AT MAXIMUM MATERIAL CONDITION.

DIM	MILLIMETERS		INCHES	
	MIN	MAX	MIN	MAX
A	8.55	8.75	0.337	0.344
B	3.80	4.00	0.150	0.157
C	1.35	1.75	0.054	0.068
D	0.35	0.49	0.014	0.019
F	0.40	1.25	0.016	0.049
G	1.27 BSC		0.050 BSC	
J	0.19	0.25	0.008	0.009
K	0.10	0.25	0.004	0.009
M	0°	7°	0°	7°
P	5.80	6.20	0.228	0.244
R	0.25	0.50	0.010	0.019

NCV4279B

PACKAGE DIMENSIONS

SO-20L
DW SUFFIX
CASE 751D-05
ISSUE F

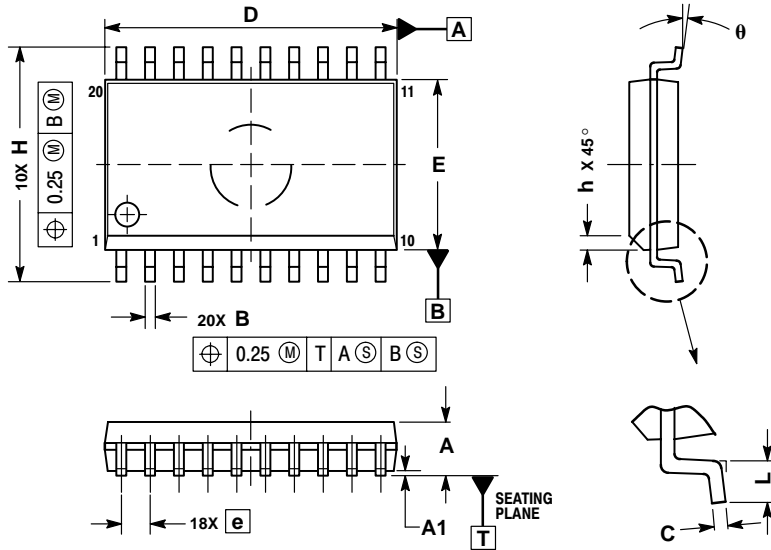

NOTES:

1. DIMENSIONS ARE IN MILLIMETERS.
2. INTERPRET DIMENSIONS AND TOLERANCES PER ASME Y14.5M, 1994.
3. DIMENSIONS D AND E DO NOT INCLUDE MOLD PROTRUSION.
4. MAXIMUM MOLD PROTRUSION 0.15 PER SIDE.
5. DIMENSION B DOES NOT INCLUDE DAMBAR PROTRUSION. ALLOWABLE PROTRUSION SHALL BE 0.13 TOTAL IN EXCESS OF B DIMENSION AT MAXIMUM MATERIAL CONDITION.

DIM	MILLIMETERS	
	MIN	MAX
A	2.35	2.65
A1	0.10	0.25
B	0.35	0.49
C	0.23	0.32
D	12.65	12.95
E	7.40	7.60
e	1.27 BSC	
H	10.05	10.55
h	0.25	0.75
L	0.50	0.90
θ	0 °	7 °

SMART REGULATOR is a registered trademark of Semiconductor Components Industries, LLC.

ON Semiconductor and  are registered trademarks of Semiconductor Components Industries, LLC (SCILLC). SCILLC reserves the right to make changes without further notice to any products herein. SCILLC makes no warranty, representation or guarantee regarding the suitability of its products for any particular purpose, nor does SCILLC assume any liability arising out of the application or use of any product or circuit, and specifically disclaims any and all liability, including without limitation special, consequential or incidental damages. "Typical" parameters which may be provided in SCILLC data sheets and/or specifications can and do vary in different applications and actual performance may vary over time. All operating parameters, including "Typicals" must be validated for each customer application by customer's technical experts. SCILLC does not convey any license under its patent rights nor the rights of others. SCILLC products are not designed, intended, or authorized for use as components in systems intended for surgical implant into the body, or other applications intended to support or sustain life, or for any other application in which the failure of the SCILLC product could create a situation where personal injury or death may occur. Should Buyer purchase or use SCILLC products for any such unintended or unauthorized application, Buyer shall indemnify and hold SCILLC and its officers, employees, subsidiaries, affiliates, and distributors harmless against all claims, costs, damages, and expenses, and reasonable attorney fees arising out of, directly or indirectly, any claim of personal injury or death associated with such unintended or unauthorized use, even if such claim alleges that SCILLC was negligent regarding the design or manufacture of the part. SCILLC is an Equal Opportunity/Affirmative Action Employer.

PUBLICATION ORDERING INFORMATION

Literature Fulfillment:

Literature Distribution Center for ON Semiconductor
P.O. Box 5163, Denver, Colorado 80217 USA
Phone: 303-675-2175 or 800-344-3860 Toll Free USA/Canada
Fax: 303-675-2176 or 800-344-3867 Toll Free USA/Canada
Email: orderlit@onsemi.com

N. American Technical Support: 800-282-9855 Toll Free USA/Canada

JAPAN: ON Semiconductor, Japan Customer Focus Center
2-9-1 Kamimeguro, Meguro-ku, Tokyo, Japan 153-0051
Phone: 81-3-5773-3850

ON Semiconductor Website: <http://onsemi.com>

For additional information, please contact your local Sales Representative.