

# NCV7681

## 100 mA Linear Current Regulator and Controller for Automotive LED Lighting

The NCV7681 consists of eight linear programmable constant current sources. The part is designed for use in the regulation and control of LED based Rear Combination Lamps and blinking functions for automotive applications. System design with the NCV7681 allows for two programmed levels for stop (100% Duty Cycle) and tail illumination (programmable Duty Cycle), or an optional external PWM control can be implemented.

LED brightness levels are easily programmed (stop is programmed to the absolute current value, tail is programmed to the duty cycle) with two external resistors. The use of an optional external ballast FET allows for power distribution on designs requiring high currents. Set back power limit reduces the drive current during overvoltage conditions. This is most useful for low power applications when no external FET is used.

The device is available in a SOIC-16 WB package with exposed pad.

### Features

- Constant Current Outputs for LED String Drive
- LED Drive Current up to 100 mA per Channel
- Open LED String Diagnostic with Open-Drain Output in All Modes
- Slew Rate Control Eliminates EMI Concerns
- Low Dropout Operation for Pre-Regulator Applications
- External Modulation Capable
- On-chip 800 Hz Tail PWM Dimming
- Single Resistor for Stop Current Set Point
- Single Resistor for Tail Dimming Set Point
- Overvoltage Set Back Power Limitation
- AEC-Q100 Qualified and PPAP Capable
- 16 Lead SOICW Exposed Pad
- Improved EMC Performance
- Latch-Off Function on Open String (NCV7681L)
  - ◆ Restart Option of Unaffected Strings
- Over Temperature Fault Reporting
- These are Pb-Free Devices

### Applications

- Rear Combination Lamps (RCL)
- Daytime Running Lights (DRL)
- Fog Lights
- Center High Mounted Stop Lamps (CHMSL) Arrays
- Turn Signal and Other Externally Modulated Applications
- Signature Lamp



ON Semiconductor®

[www.onsemi.com](http://www.onsemi.com)

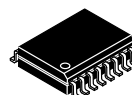

SOIC-16 WB  
PW SUFFIX  
CASE 751DW

### MARKING DIAGRAM

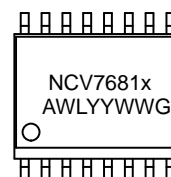

NCV7681 = Specific Device Code  
x = A (No Latch-Off Function)  
or L (Latch-Off Function)  
A = Assembly Location  
WL = Wafer Lot  
YY = Year  
WW = Work Week  
G = Pb-Free Device

### ORDERING INFORMATION

Device	Package	Shipping†
NCV7681APWR2G	SOIC-16WB (Pb-Free)	1000 / Tape & Reel
NCV7681LPWR2G	SOIC-16WB (Pb-Free)	1000 / Tape & Reel

†For information on tape and reel specifications, including part orientation and tape sizes, please refer to our Tape and Reel Packaging Specifications Brochure, BRD8011/D.

# NCV7681

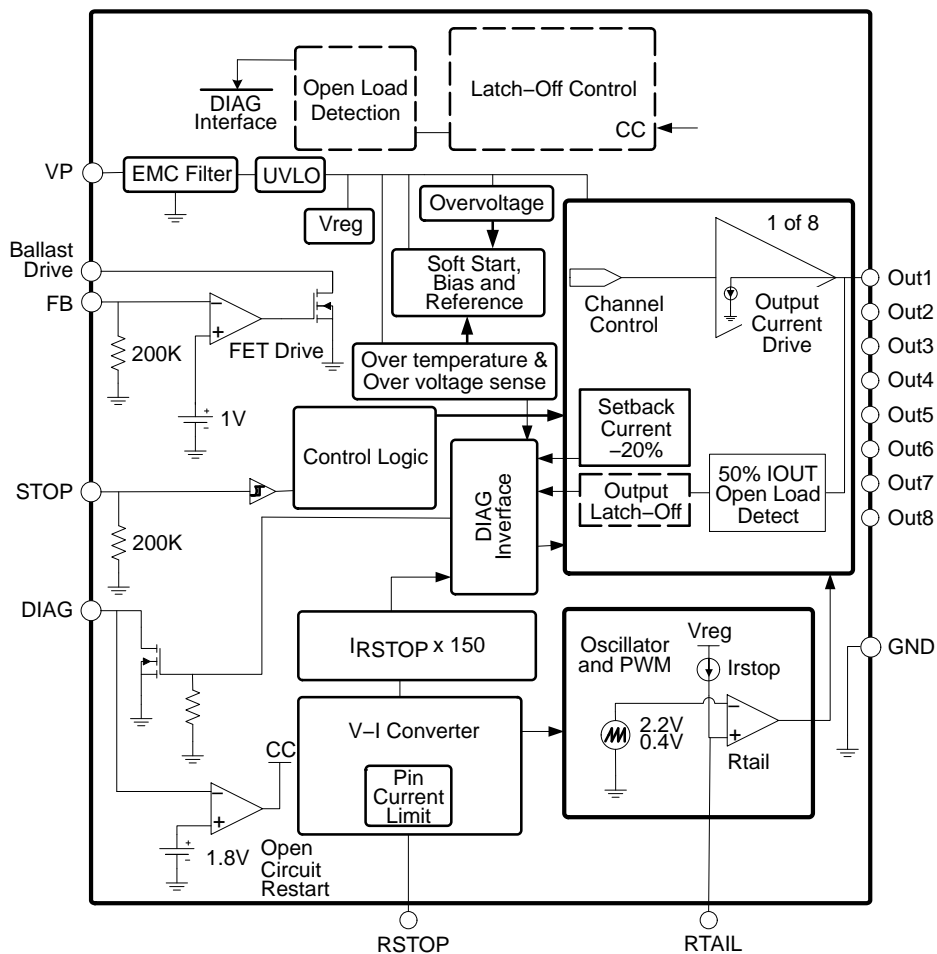

Boxes with dotted lines signify NCV7681L only.

**Figure 1. Block Diagram**

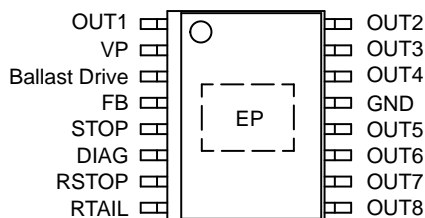

**Figure 2. Pinout Diagram**

# NCV7681

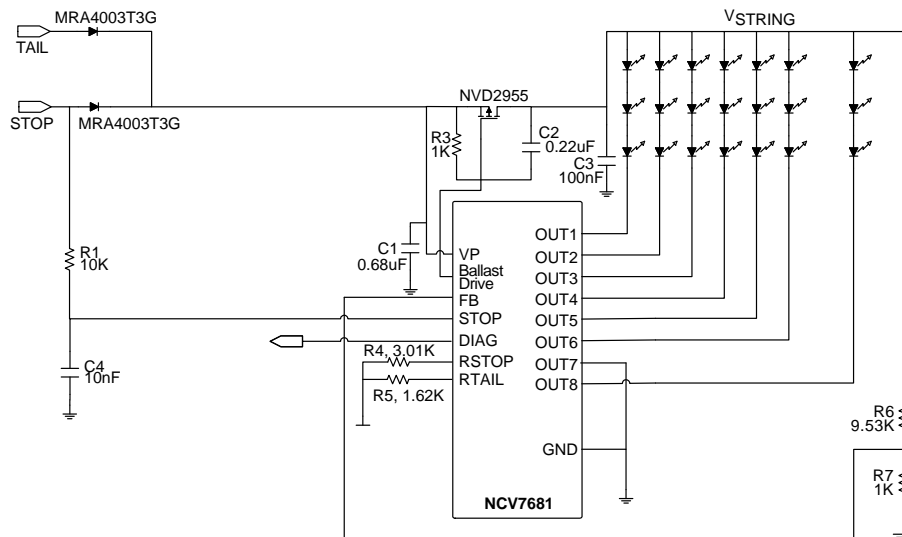

**Figure 3. Application Diagram with External FET Ballast Transistor**

R6 and R7 values shown yield 10.5 V regulation on  $V_{STRING}$ .

C1 is for line noise and stability considerations.

C3 is for EMC considerations.

Unused OUTx channels should be shorted to ground as OUT7 shows in this example.

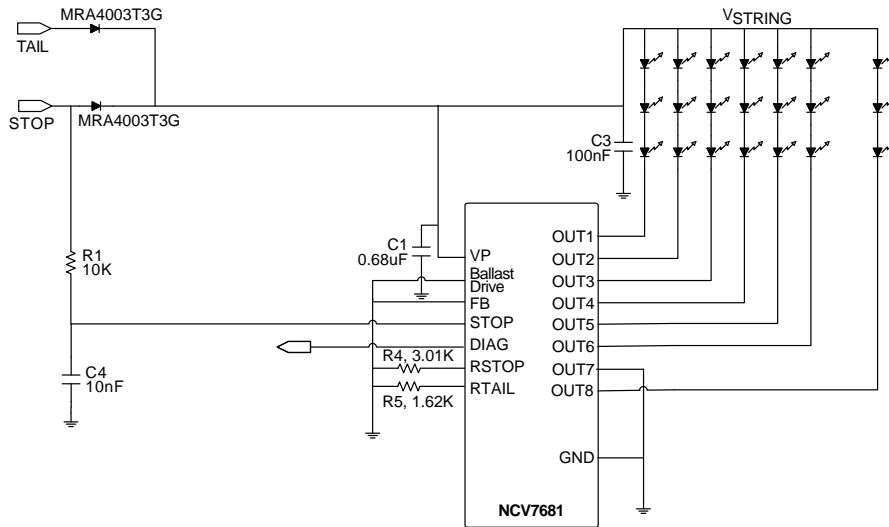

**Figure 4. Application Diagram without the FET Ballast Transistor**

When using the NCV7681 without the FET ballast transistor, tie the FB pin and Ballast Drive pin to GND.

# NCV7681

**Table 1. APPLICATION I/O TRUTH TABLE**

STOP INPUT	TAIL MODE	OUTx LATCH OFF (w/ $\overline{LO}$ = GND)	OUTX CURRENT	FAULT STATE*	DIAG STATE**
0	0	NCV7681A	OFF	-	1
1	X	NCV7681A	$I_{STOP}$	NORMAL	0
1	X	NCV7681A	$I_{STOP}$	OPEN CIRCUIT***	1
1	X	NCV7681L	OFF	OPEN CIRCUIT***	1
0	1	NCV7681A	PWM	NORMAL	0
0	1	NCV7681A	PWM	OPEN CIRCUIT***	PWM

Reference Figures below.

X = don't care

0 = LOW

1 = HIGH

\* Open Circuit, RSTOP Current Limit, Set Back Current Limit down 20%, and thermal shutdown

\*\*Pull-up resistor to DIAG required.

\*\*\* OPEN CIRCUIT = Any string open.

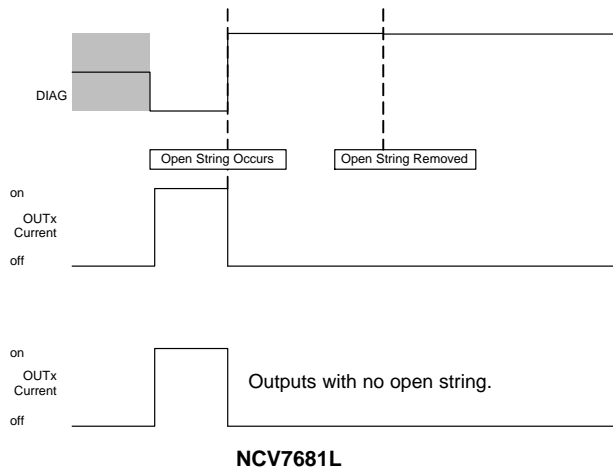

**Figure 5. DIAG timing diagram WITH Open String Latch Active  
All outputs latch off.**

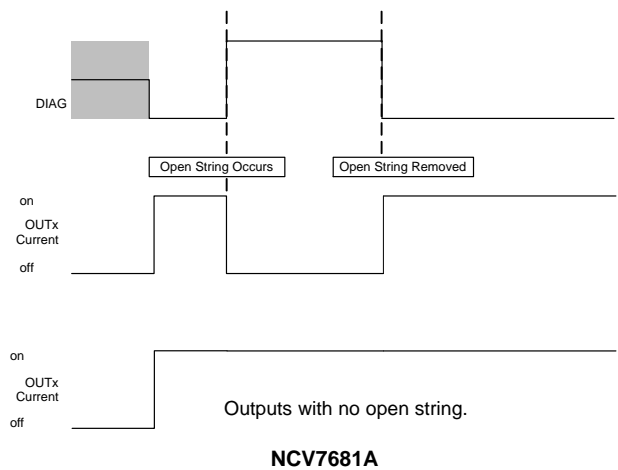

**Figure 6. DIAG timing diagram WITHOUT Open String Latch Active  
No outputs are turned off.  
DIAG will report the state.**

# NCV7681

**Table 2. PIN FUNCTION DESCRIPTION** (16 Pin SO Wide Exposed Pad Package)

Pin #	Label	Description
1	OUT1	Channel 1 constant current output to LED. Unused pin should be grounded.
2	VP	Supply Voltage Input.
3	Ballast Drive	Gate drive for external power distribution PFET. Ground if not used.
4	FB	Feedback Sense node for $V_P$ regulation. Use feedback resistor divider or connect to $V_P$ with a 10k resistor.
5	STOP	Stop Logic Input. External Modulation Input.
6	DIAG	Open-drain diagnostic output. Reporting Open Circuit, $R_{STOP}$ Current Limit, and Overvoltage Set Back Current down 20%. Normal Operation = LOW. Ground if not used.
7	RSTOP	Stop current bias program resistor.
8	RTAIL	Tail current duty cycle PWM program resistor. Ground if using external modulation.
9	OUT8	Channel 8 constant current output to LED. Unused pin should be grounded.
10	OUT7	Channel 7 constant current output to LED. Unused pin should be grounded.
11	OUT6	Channel 6 constant current output to LED. Unused pin should be grounded.
12	OUT5	Channel 5 constant current output to LED. Unused pin should be grounded.
13	GND	Ground.
14	OUT4	Channel 4 constant current output to LED. Unused pin should be grounded.
15	OUT3	Channel 3 constant current output to LED. Unused pin should be grounded.
16	OUT2	Channel 2 constant current output to LED. Unused pin should be grounded.
epad*	epad	Ground. Do not connect to pcb traces other than GND.

\*Grounding will provide better thermal and electrical performance.

# NCV7681

**Table 3. MAXIMUM RATINGS** (Voltages are with respect to device substrate.)

Rating	Value	Unit
Supply Input (VP, Ballast Drive, STOP, DIAG) DC Peak Transient	-0.3 to 40 40	V
Output Pin Voltage (OUTX)	-0.3 to 40	V
Output Pin Current (OUTX)	200	mA
DIAG Pin Current	10	mA
Input Voltage (RTAIL, RSTOP, FB)	-0.3 to 3.6	V
Junction Temperature, T <sub>J</sub>	-40 to 150	°C
Peak Reflow Soldering Temperature: Lead-free 60 to 150 seconds at 217°C (Note 1)	260 peak	°C

Stresses exceeding those listed in the Maximum Ratings table may damage the device. If any of these limits are exceeded, device functionality should not be assumed, damage may occur and reliability may be affected.

**Table 4. ATTRIBUTES**

Characteristic	Value
ESD Capability Human Body Model Machine Model	≥ ± 4.0 kV ≥ ± 200 V
Moisture Sensitivity (Note 1)	MSL3
Storage Temperature	-55 to 150°C
Package Thermal Resistance (Note 2) SOIC-16 WB EP Junction-to-Board (R <sub>ψJB</sub> ) Junction-to-Ambient (R <sub>θJA</sub> ) Junction-to-Pin (R <sub>ψJL</sub> )	15°C/W 73°C/W 43°C/W

- For additional information, see or download ON Semiconductor's Soldering and Mounting Techniques Reference Manual, SOLDERRM/D, and Application Note AND8003/D.
- Values represent typical still air steady-state thermal performance on 1 oz. copper FR4 PCB with 650 mm<sup>2</sup> copper area with OUT1-OUT8 dissipating 50 mW each.

# NCV7681

**Table 5. ELECTRICAL CHARACTERISTICS**

(4.5 V < VP < 16 V, STOP = VP, RSTOP = 3.01 kΩ, RTAIL = 1.62 kΩ, -40°C ≤ TJ ≤ 150°C, unless otherwise specified.)

Characteristic	Conditions	Min	Typ	Max	Unit
<b>GENERAL PARAMETERS</b>					
Quiescent Current (IOUTx = 50 mA) STOP mode Tail mode Fault mode (Note 5)	VP = 16 V VP = 16 V VP = 16 V, STOP = 0 V, OUTx = 0 mA, Disconnected output	- - -	6 5 -	12 12 2.0	mA
Driver Ground Pin Current (pin12)	IOUT1 to IOUT8 = 50 mA	-	400	500	mA
Output Under Voltage Lockout	VP Rising	3.8	4.1	4.4	V
Output Under Voltage Lockout Hysteresis		-	200	-	mV
Open Load Disable Threshold		7.2	7.7	8.2	V
Open Load Disable Hysteresis		-	200	-	mV
<b>THERMAL LIMIT</b>					
Thermal Shutdown	(Note 3)	150	175	-	°C
Thermal Hysteresis	(Note 3)	-	15	-	°C
<b>CURRENT SOURCE OUTPUTS</b>					
Output Current	OUTX = 0.5 V, TJ = 25°C, 150°C OUTX = 1 V, RSTOP = 1.5 K	45 90	50 100	55 110	mA
Maximum Regulated Output Current	0.5V to 16V	100	-	-	mA
Current Matching	$\left[ \frac{2I_{OUTx(min)}}{I_{OUTx(min)} + I_{OUTx(max)}} - 1 \right] \times 100$ $\left[ \frac{2I_{OUTx(max)}}{I_{OUTx(min)} + I_{OUTx(max)}} - 1 \right] \times 100$	-4	0	4	%
Line Regulation	9 V ≤ VP ≤ 16 V	-	1.2	6.0	mA
Open Circuit Detection Threshold	25 mA 50 mA	25 35	50 50	75 65	% of Output Current
Current Slew Rate	Iout = 44 mA, 10% to 90% points	-	6	15	mA/μs
Overvoltage Set Back Threshold	@ 99% Iout	16.0	17.2	18.4	V
Overvoltage Set Back Current	VP = 20 V (Note 4)	-	78	-	%Iout
Diag Reporting of Set Back Current		-	80	-	%Iout
Output Off Leakage	EN = high	-	-	1	μA
<b>FET DRIVER</b>					
Ballast Drive DC Bias Sink Current	FB = 1.5 V, Ballast Drive = 3 V FB = 0.5 V, Ballast Drive = 3 V	- 4	1.0 13	2.4 20	mA
Ballast Drive Reference Voltage		0.92	1.00	1.08	V
<b>STOP LOGIC</b>					
Input High Threshold		0.75	1.25	1.75	V
Input Low Threshold		0.70	1.00	1.44	V
VIN Hysteresis		100	250	400	mV
Input Impedance	Vin = 14 V	120	200	300	kΩ

3. Designed to meet these characteristics over the stated voltage and temperature recommended operating ranges, though may not be 100% parametrically tested in production.

4. The output current degrades at a rate of 8%/V.

5. This test parameter applies only to the NCV7681LPWR2G.

# NCV7681

**Table 5. ELECTRICAL CHARACTERISTICS**

(4.5 V < VP < 16 V, STOP = VP, RSTOP = 3.01 kΩ, RTAIL = 1.62 kΩ, -40°C ≤ TJ ≤ 150°C, unless otherwise specified.)

Characteristic	Conditions	Min	Typ	Max	Unit
----------------	------------	-----	-----	-----	------

## CURRENT PROGRAMMING

RSTOP Bias Voltage	Stop current programming voltage	0.94	1.00	1.06	V
RSTOP K multiplier I <sub>OUTX</sub> /I <sub>RSTOP</sub>		–	150	–	–
RSTOP Over Current Detection	RSTOP = 0 V	0.70	1.00	1.45	mA
RTAIL Bias Current	Tail duty cycle programming current	290	330	370	μA
Duty Cycle	RTAIL = 0.49 V RTAIL = 0.76 V RTAIL = 1.66 V	3.5 17 59.5	5 20 70	6.5 23 80.5	%

## DIAG OUTPUT

Output Low Voltage	DIAG Active, I <sub>DIAG</sub> = 1 mA	–	0.1	0.40	V
DIAG Output Leakage	V <sub>DIAG</sub> = 5 V	–	–	10	μA
Open Load Reset Voltage on DIAG	(Note 5)	1.6	1.8	2.0	V

## AC CHARACTERISTICS

Stop Turn-on Delay Time	V(STOP) > 1.75 V to I(OUTx) = 90%	–	14	45	μsec
Stop Turn-off Delay Time	V(STOP) < 0.75 V to I(OUTx) = 10%	–	14	45	μsec
PWM Frequency	STOP = 0 V	400	800	1200	Hz
Open Circuit to DIAG Reporting	4.8 mA pull-up to VP, V(DIAG) > 1.5 V	1	2	4	μs
VP Turn-on Time		0.55	0.80	1.2	msec

3. Designed to meet these characteristics over the stated voltage and temperature recommended operating ranges, though may not be 100% parametrically tested in production.
4. The output current degrades at a rate of 8%/V.
5. This test parameter applies only to the NCV7681LPWR2G.



TYPICAL CHARACTERISTICS

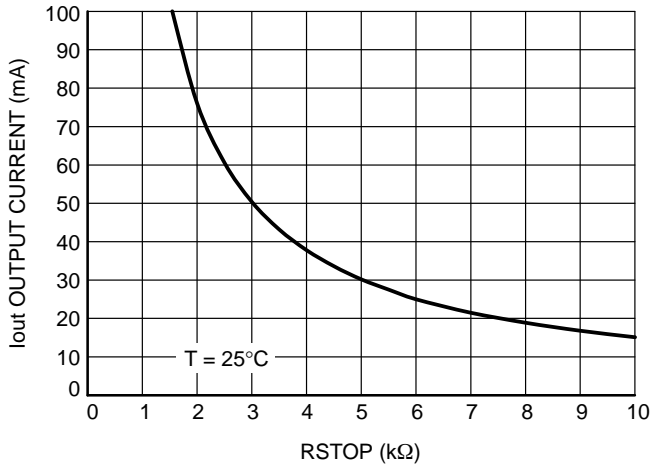

Figure 7. I<sub>out</sub> vs. R<sub>STOP</sub>

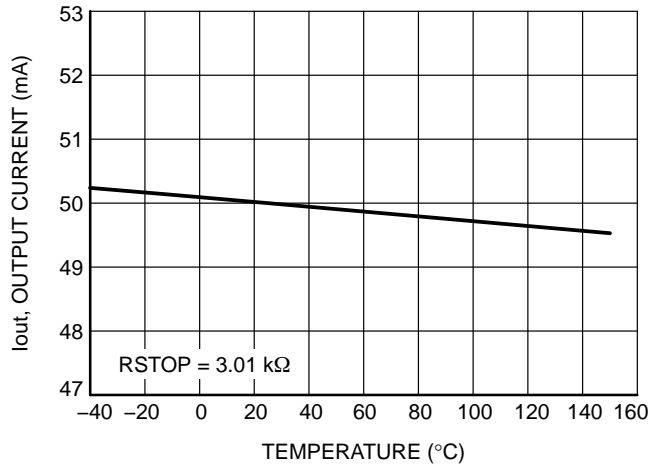

Figure 8. I<sub>out</sub> vs. Temperature

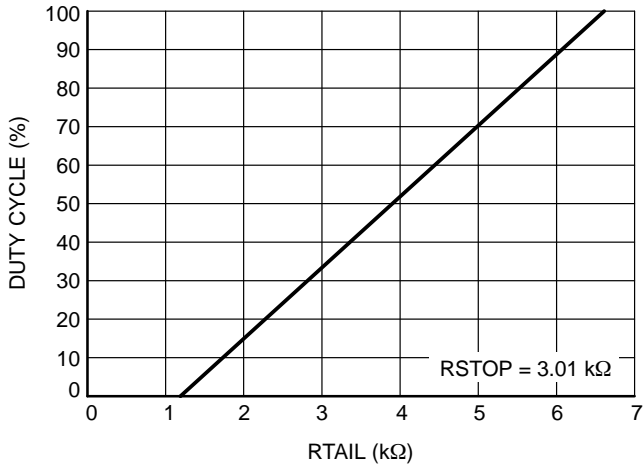

Figure 9. Duty Cycle vs. R<sub>TAIL</sub>

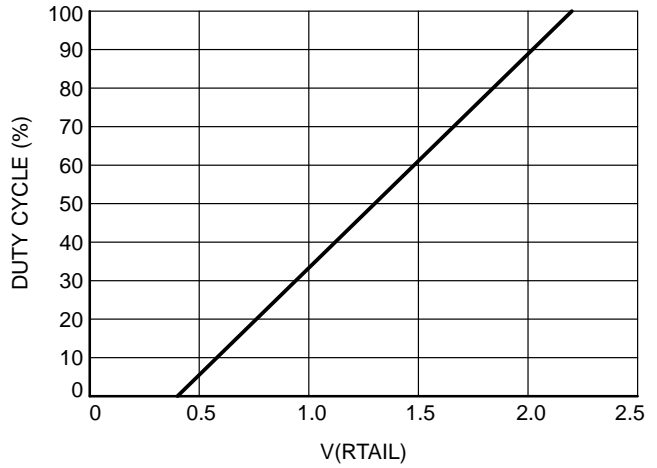

Figure 10. Duty Cycle vs. V(R<sub>TAIL</sub>)

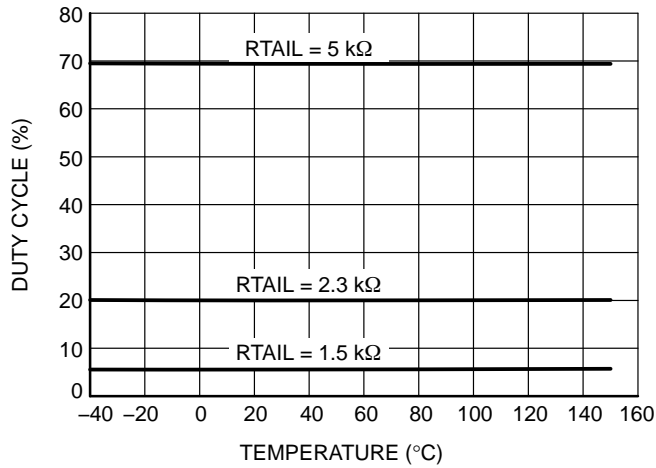

Figure 11. Duty Cycle vs. Temperature

TYPICAL CHARACTERISTICS

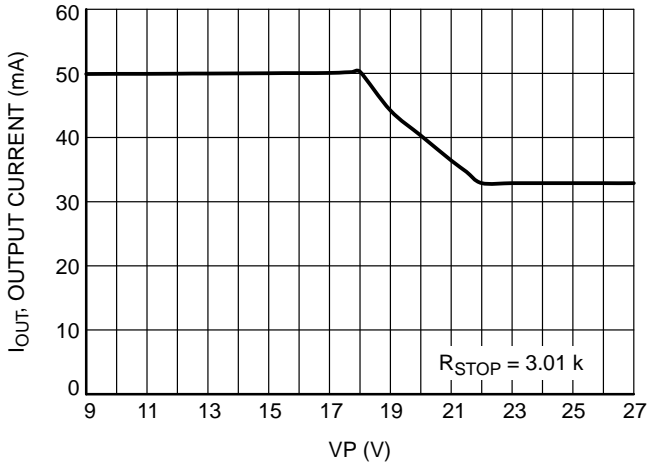

Figure 12. I<sub>OUT</sub> vs. V<sub>P</sub>

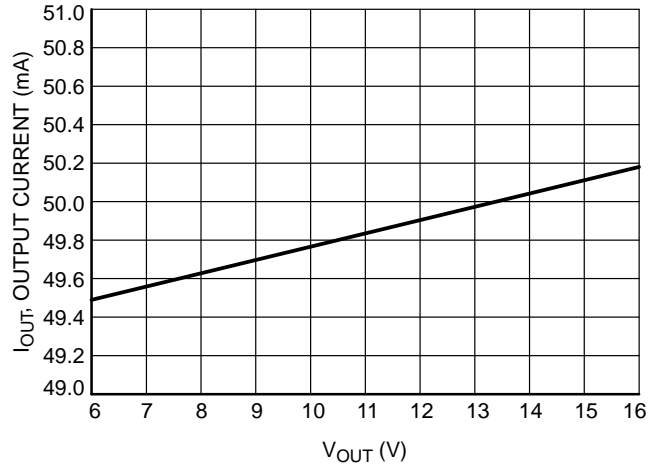

Figure 13. I<sub>OUT</sub> Line Regulation

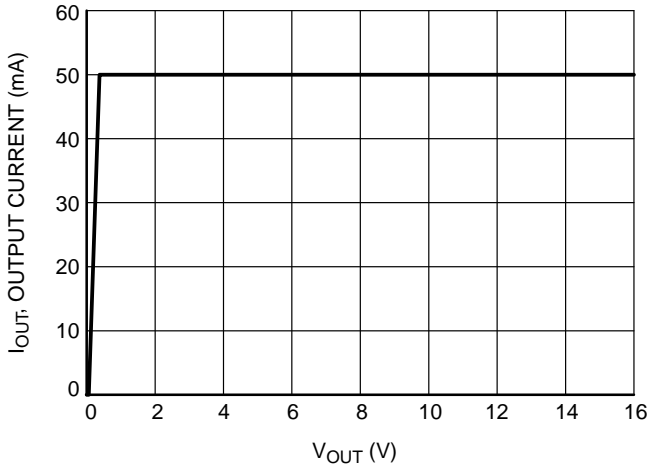

Figure 14. I<sub>OUT</sub> vs. V<sub>OUT</sub>

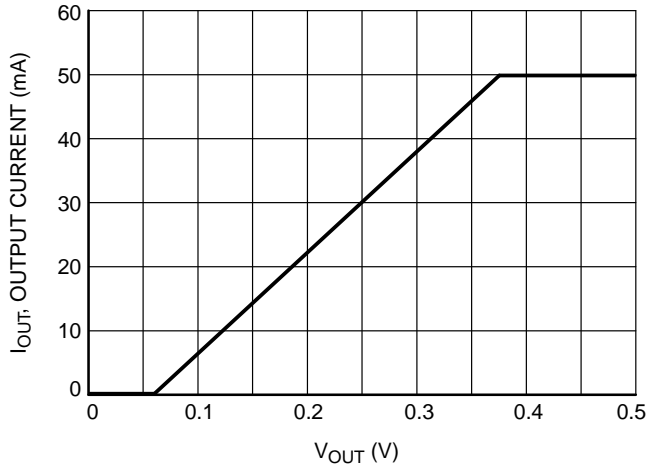

Figure 15. I<sub>OUT</sub> vs. V<sub>OUT</sub>

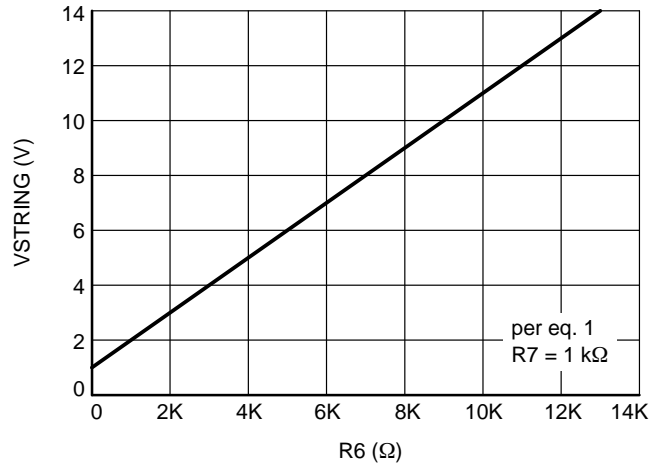

Figure 16. V<sub>STRING</sub> vs. R<sub>6</sub>

TYPICAL PERFORMANCE CHARACTERISTICS

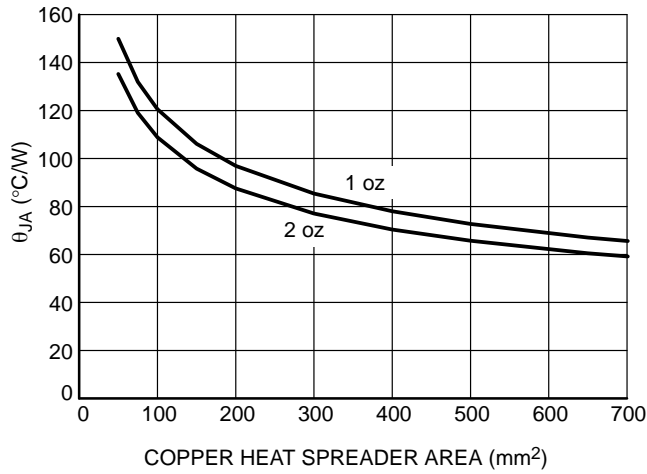

Figure 17.  $\theta_{JA}$  vs. Copper Spreader Area

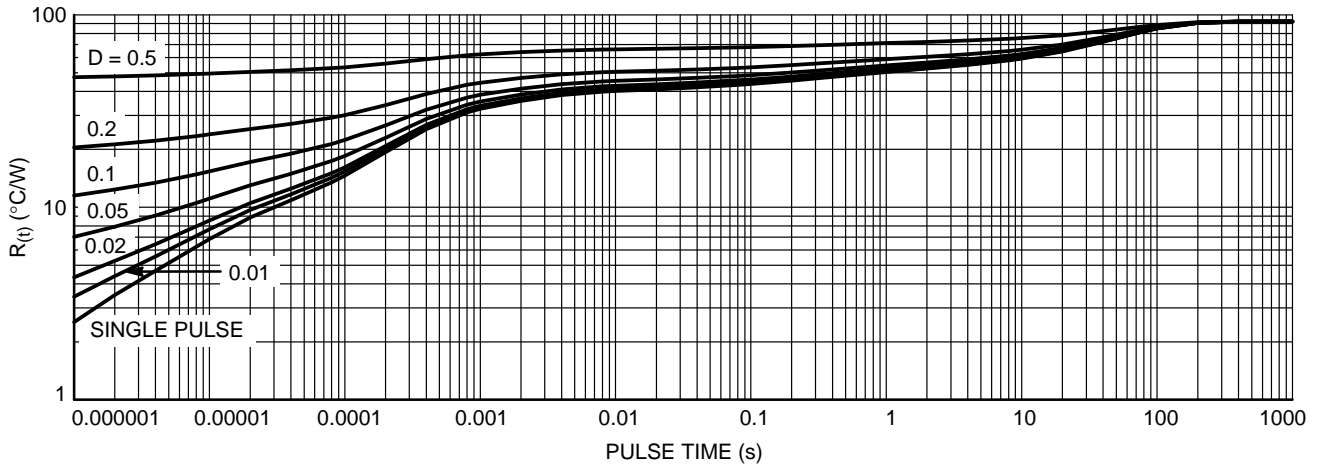

Figure 18. Thermal Duty Cycle Curves on 500 mm<sup>2</sup> Spreader Test Board

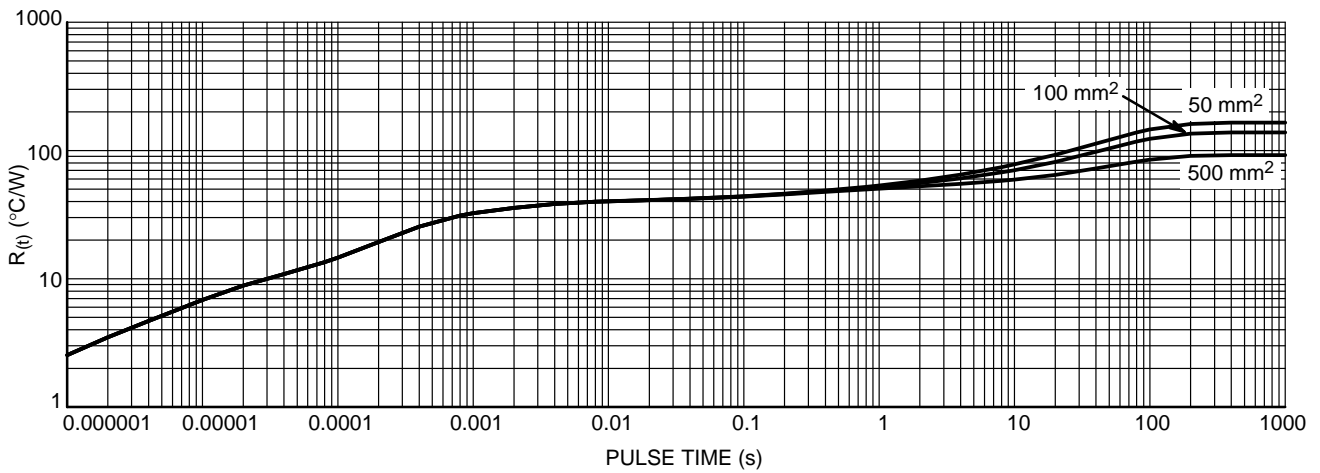

Figure 19. Single Pulse Heating Curve

DETAILED OPERATING DESCRIPTION

General

The NCV7681 device is an eight channel LED driver whose output currents up to 100 mA/channel are programmed by an external resistor. The target application for the device is in automotive Rear Combination Lighting (RCL) systems.

The STOP logic input switches the two modes of the IC. While in the STOP mode (high), the duty cycle of the outputs is at 100%. When STOP is low, the duty cycle of the outputs is programmed via an external resistor on the RTAIL pin.

A logic output (DIAG) communicates open circuit of the LED driver outputs back to the microprocessor. DIAG requires a pull-up resistor for proper operation.

An optional external control for a ballast transistor helps distribute the system power.

Latch Off (NCV7681L)

The Latch Off feature applies only to the NCV7681L.

Automotive requirements sometime dictate all outputs turn off if one of the outputs is an open circuit. This eliminates driving with partial illuminated lights. The

module will either display all LED strings or no LED strings at all. This function is designed into the NCV7681L.

Each output has its own sensing circuitry. An open string detection on any output latches off all 8 outputs. There are three means to reinitiate the IC drivers.

1. Forcing the DIAG pin below the Open Circuit Reset Voltage (1.8 V typical).
2. Toggling the ENABLE input
3. A complete power down of the device below the Under Voltage Lockout threshold including hysteresis (3.9 V typical).

Open Load Detection

Open load detection has an under voltage lockout feature to remove the possibility of turning off the device while it is powering up. The Open Load Disable Threshold is 7.7 V (typ). Open load detection becomes active above this threshold. Current is monitored internal to the NCV7681 device and an open load is flagged when the current is 1/2 of the targeted output current.

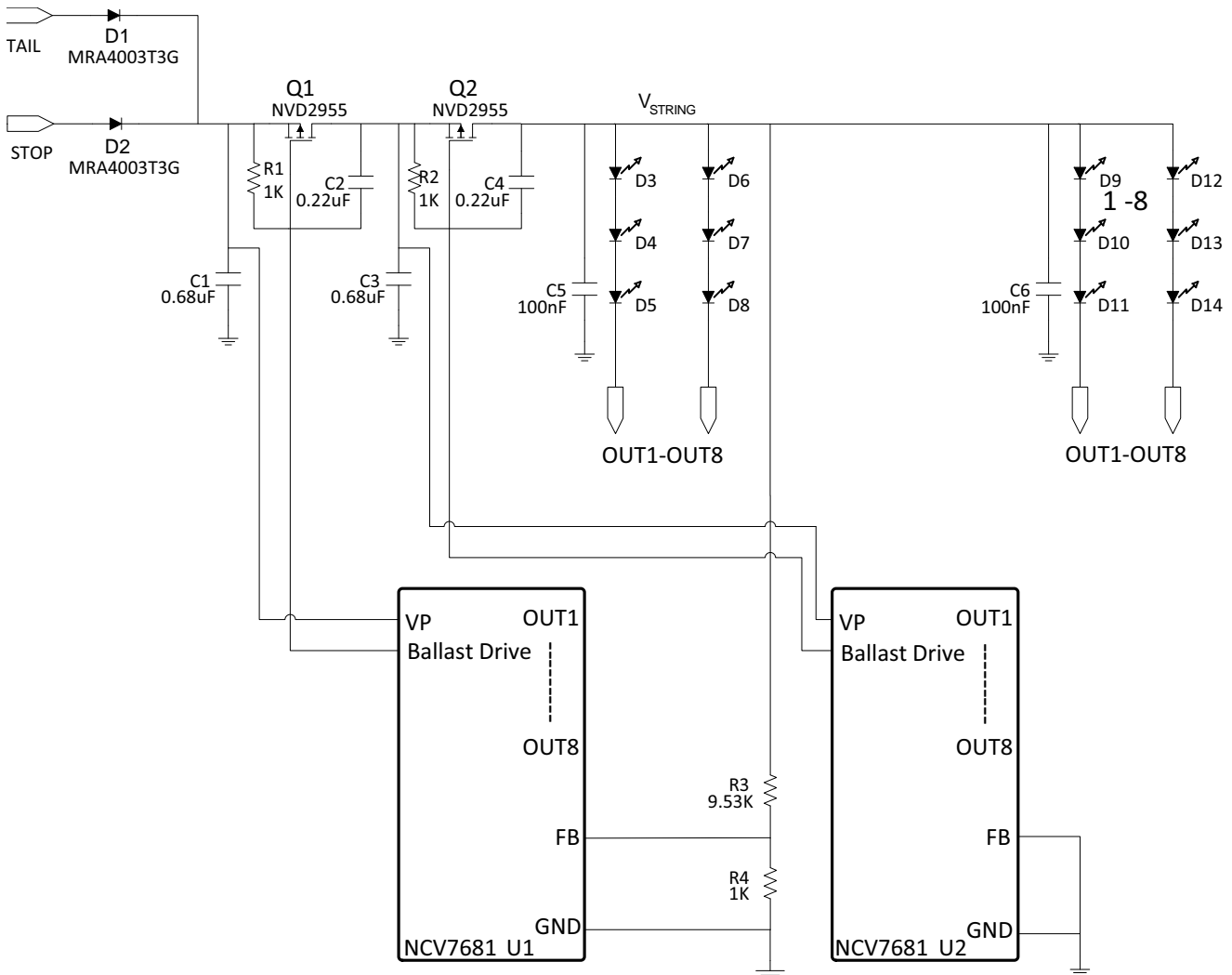

Figure 20.

## DIAG

The logic DIAG pin's main function is to alert the controlling microprocessor an open string has occurred on one of the outputs (DIAG high = open string). Reference Table 1 for details on logic performance.

Open circuit conditions are reported when the outputs are actively driven. When operating in STOP mode the DIAG signal is a DC signal. When operating in TAIL the DIAG signal is a PWM signal reporting open circuit when the output drive is active.

## Ballast Drive

The use of an external FET device (NVD2955) helps distribute the system power. A DC voltage regulation system is used which regulates the voltage at the top (anode) of the LED strings (Vstring). This has the effect of limiting the power in the NCV7681 by setting the voltage on the IOUTx pins specific to each customer application. The Ballast Drive pin provides the drive in the feedback loop from the FB pin. In steady state, the voltage is regulated at the feedback voltage (FB). A simple voltage divider helps set the voltage at Vstring. Unlike other systems, the ballast drive current does not turn off in a leakage state when turned off (FB high), but instead provides 1 mA of current providing a faster response of the system loop. This sets the gate voltage of the NVD2955 to 1 V at 25°C.

## Parallel Outputs

The maximum rating per output is 100 mA. In order to increase system level LED string current, parallel combinations of any number of outputs is allowed. Combining all 8 outputs will allow for a maximum system level string current design of 800 mA.

## Unused Outputs

Unused outputs should be shorted to ground. The NCV7681 detects the condition during power-up using the open load disable threshold and disables the open circuit detection circuitry.

## Programmability

Strings of LEDs are a common configuration for RCL applications. The NCV7681 provides eight matched outputs allowing individual string drive with current set by a single resistor. Output currents are mirrored and matched within ±4% at hot temperature.

A high STOP condition sets the output current using equation 1 below.

A low STOP condition, modulates the output currents at a duty cycle (DC) programmed using equation 2 below.

Note, current limiting on RSTOP limits the current which can be referenced from the RSTOP Pin. Exceeding the RSTOP Current Limit will set the output current to less than 100 mA, and the DIAG Pin will go high. This helps limit output current (brightness and power) for this type of fault.

The average ISTOP Duty Cycle current provides the dimmed tail illumination function and assures a fixed

brightness level for tail. The PWM generator's fixed frequency (800 Hz typ.) oscillator allows flicker-free illumination. PWM control is the preferred method for dimming LEDs.

The diagnostic function allows the detection of an open in any one of the output circuits. The active-low diagnostic output (DIAG) is coincident with the STOP input and the ON state in the tail mode. DIAG remains high (pulled up) if an open load is detected in any LED string when STOP is high.

## Output Current Programming

Reference Figure 7 (typ performance graph) to choose programming resistor (RSTOP) value for stop current. Reference Figure 9 Typical Performance Graph (Duty Cycle vs. RTAIL) to choose a typical value programming resistor for output duty cycle (with a typical RSTOP value of 3.01 kΩ). Note the duty cycle is dependent on both RSTOP and RTAIL values. RSTOP should always be chosen first as the stop current is only dependent on this value.

Alternatively, the equations below can be used to calculate a typical value and used for worst case analysis.

Set the Stop Current using RSTOP

$$I_{OUTX} = 150 \cdot \frac{RSTOP\_Bias\_Voltage}{RSTOP} \quad (\text{eq. 1})$$

RSTOP Bias Voltage = 1 V (typ)

## Set the Duty Cycle (DC) using RTAIL

$$RTAIL = 1.8 \cdot RSTOP(DC + 0.22) \quad (\text{eq. 2})$$

DC = duty cycle expressed in fractional form. (e.g. 0.50 is equivalent to 50% duty cycle) (ground RTAIL when using external modulation)

Output Current is directly tested per the electrical parameter table to be ±10% (with RSTOP = 3.01 KΩ) or 45 mA (min), 50 mA (typ), 55 mA (max) at room and hot temperature.

Duty Cycle will vary according to the changes in RTAIL Voltage and RTAIL Bias Current (generated from the current through RSTOP).

Voltage errors encompass generator errors (0.4 V to 2.2 V) and comparator errors and are included in testing as the Duty Cycle. Typical duty cycle measurements are 5% with RTAIL = 0.49 V and 70% with RTAIL = 1.66 V.

RTAIL Bias Current errors are measured as RTAIL Bias Current and vary as 290 μA (min), 330 μA (typ), and 370 μA (max) with RSTOP = 3.01 kΩ.

The error duality originating from both the internal current source generated on the RSTOP pin and the comparator voltage thresholds of the RTAIL pin combined with the choice of duty cycle levels make it difficult to specify duty cycle minimum and maximum limits, but worst case conditions can be calculated when considering the variation in the voltage threshold and current source. Duty Cycle variation must include the direct duty cycle as specified in the electrical parameter table plus an additional error due to the Istop current which generates this voltage in the system.

## **RSTOP Over Current Protection**

Over Current protection has been included for the RSTOP pin. Without protection, the device performance could cause excessive high current and potential damage to the external LEDs. Detection of the RSTOP over current event (RSTOP to ground) is 1 mA (typ) and is current limited to 2.2 mA (typ). Output drive currents will limit to typically 65 mA.

Note – A feature of the NCV7681 device includes operation of the device during a short circuit on the RSTOP pin. Iout is decreased during the STOP condition and the TAIL duty cycle is reduced to less than 40% by reducing the voltage on the RTAIL pin to 2/3 of normal operation.

## **Set Back Current**

Automotive battery systems have wide variations in line supply voltage. Low dropout is a key attribute for providing

consistent LED light output at low line voltage. Unlike adjustable regulator based constant current source schemes where the set point resistor resides in the load path, the NCV7681's set point resistor lies outside the LED load path, and aids in the low dropout capability.

Setback Current Limit is employed during high voltage. During a Setback Current Limit event, the drive current is reduced resulting in lower power dissipation on the IC. This occurs during high battery voltage ( $V_P > 16\text{ V}$ ). In this way the NCV7681 can operate in extreme conditions and still provide a controlled level of light output. The Setback Current (–20%) condition is reported on the DIAG Pin.

Activation of the set back current feature provides a roll-off rate of –8%/V.

# NCV7681

## PACKAGE DIMENSIONS

### SOIC-16 WB, EP CASE 751DW ISSUE A

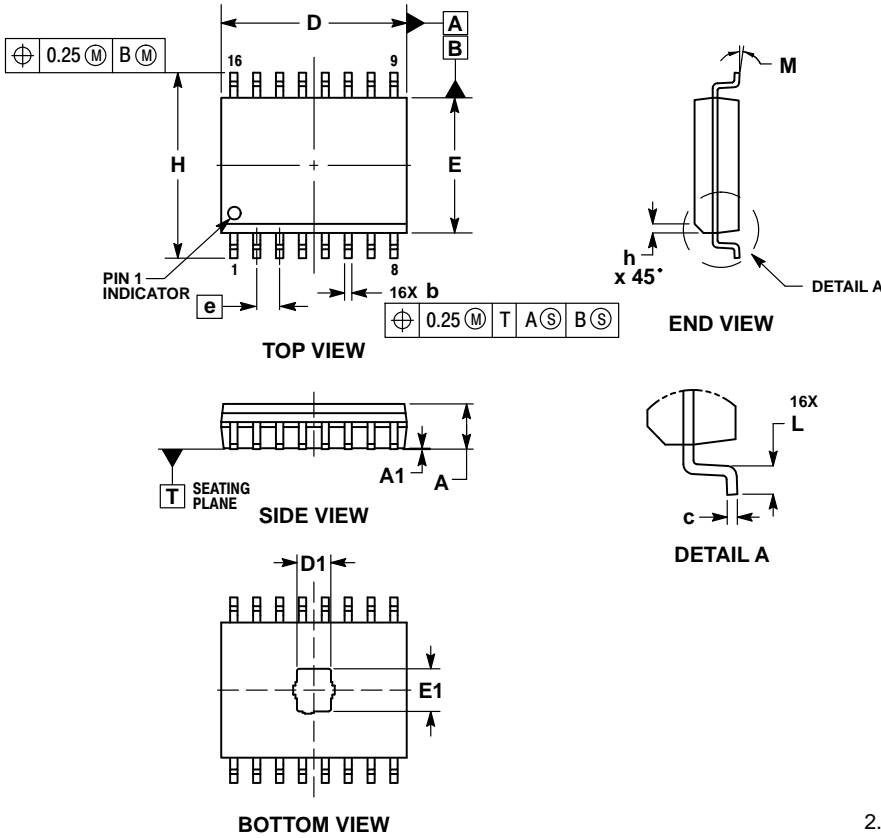

**NOTES:**

1. DIMENSIONING AND TOLERANCING PER ASME Y14.5M, 1994.
2. CONTROLLING DIMENSION: MILLIMETERS.
3. DIMENSION b DOES NOT INCLUDE DAMBAR PROTRUSION. DAMBAR PROTRUSION SHALL BE 0.13 TOTAL IN EXCESS OF b DIMENSION AT MAXIMUM MATERIAL CONDITION.
4. DIMENSIONS D AND E DO NOT INCLUDE MOLD PROTRUSIONS.
5. MAXIMUM MOLD PROTRUSION OR FLASH TO BE 0.15 PER SIDE.

DIM	MILLIMETERS	
	MIN	MAX
A	2.35	2.65
A1	0.00	0.10
b	0.35	0.49
c	0.25	0.32
D	10.15	10.45
D1	1.79	2.00
E	7.40	7.60
E1	2.27	2.47
e	1.27 BSC	
H	10.05	10.55
h	0.53 REF	
L	0.50	0.90
M	0°	7°

### RECOMMENDED SOLDERING FOOTPRINT

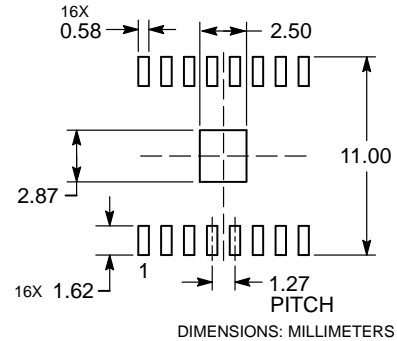

ON Semiconductor and are trademarks of Semiconductor Components Industries, LLC dba ON Semiconductor or its subsidiaries in the United States and/or other countries. ON Semiconductor owns the rights to a number of patents, trademarks, copyrights, trade secrets, and other intellectual property. A listing of ON Semiconductor's product/patent coverage may be accessed at [www.onsemi.com/site/pdf/Patent-Marking.pdf](http://www.onsemi.com/site/pdf/Patent-Marking.pdf). ON Semiconductor reserves the right to make changes without further notice to any products herein. ON Semiconductor makes no warranty, representation or guarantee regarding the suitability of its products for any particular purpose, nor does ON Semiconductor assume any liability arising out of the application or use of any product or circuit, and specifically disclaims any and all liability, including without limitation special, consequential or incidental damages. Buyer is responsible for its products and applications using ON Semiconductor products, including compliance with all laws, regulations and safety requirements or standards, regardless of any support or applications information provided by ON Semiconductor. "Typical" parameters which may be provided in ON Semiconductor data sheets and/or specifications can and do vary in different applications and actual performance may vary over time. All operating parameters, including "Typicals" must be validated for each customer application by customer's technical experts. ON Semiconductor does not convey any license under its patent rights nor the rights of others. ON Semiconductor products are not designed, intended, or authorized for use as a critical component in life support systems or any FDA Class 3 medical devices or medical devices with a same or similar classification in a foreign jurisdiction or any devices intended for implantation in the human body. Should Buyer purchase or use ON Semiconductor products for any such unintended or unauthorized application, Buyer shall indemnify and hold ON Semiconductor and its officers, employees, subsidiaries, affiliates, and distributors harmless against all claims, costs, damages, and expenses, and reasonable attorney fees arising out of, directly or indirectly, any claim of personal injury or death associated with such unintended or unauthorized use, even if such claim alleges that ON Semiconductor was negligent regarding the design or manufacture of the part. ON Semiconductor is an Equal Opportunity/Affirmative Action Employer. This literature is subject to all applicable copyright laws and is not for resale in any manner.

### PUBLICATION ORDERING INFORMATION

**LITERATURE FULFILLMENT:**

Literature Distribution Center for ON Semiconductor  
19521 E. 32nd Pkwy, Aurora, Colorado 80011 USA  
**Phone:** 303-675-2175 or 800-344-3860 Toll Free USA/Canada  
**Fax:** 303-675-2176 or 800-344-3867 Toll Free USA/Canada  
**Email:** [orderlit@onsemi.com](mailto:orderlit@onsemi.com)

**N. American Technical Support:** 800-282-9855 Toll Free  
USA/Canada  
**Europe, Middle East and Africa Technical Support:**  
Phone: 421 33 790 2910  
**Japan Customer Focus Center**  
Phone: 81-3-5817-1050

**ON Semiconductor Website:** [www.onsemi.com](http://www.onsemi.com)

**Order Literature:** <http://www.onsemi.com/orderlit>

For additional information, please contact your local Sales Representative