

# Low power compandor

# NE/SA576

## DESCRIPTION

The NE/SA576 is a unity gain level programmable compandor designed for low power applications. The NE576 is internally configured as an expander and a compressor to minimize external component count.

The NE576 can operate at 1.8V. During normal operations, the NE576 can operate from at least a 2V battery. If the battery voltage drops to 1.8V, this part will still continue to function, however, turning on the part at a  $V_{CC}$  of 1.8V requires two external resistors to bring  $V_{REF}$  to half  $V_{CC}$ . One resistor connects between  $V_{CC}$  and  $V_{REF}$ ; the other connects from  $V_{REF}$  to ground. A typical value for these external resistors is approximately 20k. A lower value can be used, but the power consumption will go up.

The NE576 is available in a 14-pin plastic DIP and SO packages.

## FEATURES

- Operating voltage range 1.8V to 7V
- Low power consumption (1.4mA @ 3.6V)
- Over 80dB of dynamic range
- Wide input/output swing capability (rail-to-rail)
- Low external component count
- ESD hardened

## APPLICATIONS

- Cordless telephone
- Consumer audio
- Wireless microphones
- Modems
- Electric organs
- Hearing aids
- Automatic level control

## PIN CONFIGURATION

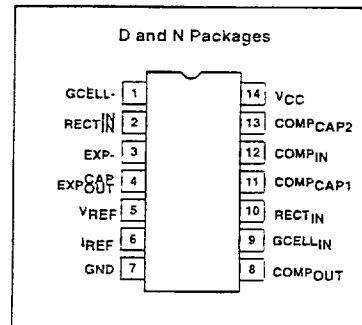

## ORDERING INFORMATION

DESCRIPTION	TEMPERATURE RANGE	ORDER CODE	DWG #
14-Pin Plastic Dual In-Line Package (DIP)	0 to +70°C	NE576N	0405B
14-Pin Plastic Small Outline (SO)	0 to +70°C	NE576D	0175D
14-Pin Plastic Dual In-Line Package (DIP)	-40 to +85°C	SA576N	0405B
14-Pin Plastic Small Outline (SO)	-40 to +85°C	SA576D	0175D

## ABSOLUTE MAXIMUM RATINGS

SYMBOL	PARAMETER	RATING		UNITS
		NE576	SA576	
$V_{CC}$	Supply voltage	8	8	V
$T_A$	Operating ambient temperature range	0 to +70	-40 to +85	°C
$T_{STG}$	Storage temperature range	-65 to +150	-65 to +150	°C
$\theta_{JA}$	Thermal impedance	DIP	90	°C/W
		SO	125	°C/W

# Low power compandor

# NE/SA576

## BLOCK DIAGRAM and TEST AND APPLICATION CIRCUIT

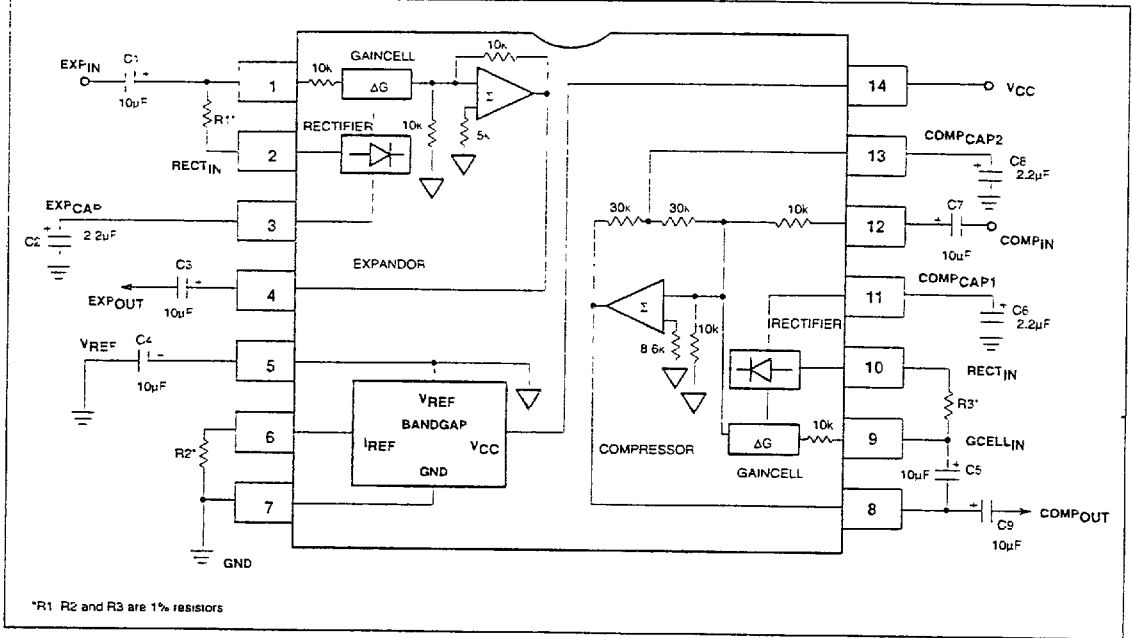

## ELECTRICAL CHARACTERISTICS

$T_A = 25^\circ\text{C}$ ,  $V_{CC} = 3.6\text{VDC}$ , compandor 0dB level =  $-20\text{dBV} = 100\text{mV}_{\text{RMS}}$ , output load  $R_L = 10\text{k}\Omega$ , Freq = 1kHz, unless otherwise specified  
 R1, R2 and R3 are 1% resistors

SYMBOL	PARAMETER	TEST CONDITIONS	LIMITS			UNITS
			NE/SA576			
			MIN	TYP	MAX	
$V_{CC}$	Supply voltage <sup>1</sup>		2	3.6	7	V
$I_{CC}$	Supply current	No signal $R_2 = 100\text{k}\Omega$		1.4	3	mA
$V_{REF}$	Reference voltage <sup>2</sup>	$V_{CC} = 3.6\text{V}$		1.8		V
$R_L$	Summing amp output load		10			$\text{k}\Omega$
THD	Total harmonic distortion	1kHz, 0dB, BW = 3.5kHz		0.25	1.5	%
$E_{NO}$	Expandor output noise voltage	BW = 20kHz, $F_S = 0\Omega$		10	30	$\mu\text{V}$
0dB	Unity gain level	0dB at 1kHz	-1.5	0.18	1.5	dB
$V_{OS}$	Output voltage offset	No signal	-150	1	150	mV
	Expandor output DC shift	No signal to 0dB	-100	7	100	mV
	Tracking error relative to 0dB output	-20dB expandor	-1.0	0.3	1.0	dB
	Crosstalk, COMP to EXP	1kHz, 0dB, $C_{REF} = 10\mu\text{F}$		-80		dB
$V_O$	Output swing low			0.2		V
	Output swing high				$V_{CC} - 0.2$	V

### NOTE:

1. Operation down to  $V_{CC} = 1.8\text{V}$  is possible, see description on front page of NE576 data sheet.
2. Reference voltage.  $V_{REF}$  is typically at  $1/2 V_{CC}$

# Low power compandor

NE/SA576

## TYPICAL PERFORMANCE CHARACTERISTICS

$V_{CC} = 3.6V$ ,  $T_A = 25^\circ C$ ,  $R_1=R_3=7.15k\Omega$ ,  $R_2=100k\Omega$ ,  $0dB$  level =  $100mV$ ,  $F_{req} = 1kHz$

