

# Stepper Motor NEMA 17

This document describes mechanical and electrical specifications for PBC Linear stepper motors; including standard, hollow, and extended shaft variations.



Phases	2
Steps/Revolution	200
Step Accuracy	±5%
Shaft Load	20,000 Hours at 1000 RPM
Axial	25 N (5.6 lbs.) Push 65 N (15 lbs.) Pull
Radial	29 N (6.5 lbs.) At Flat Center
IP Rating	40
Approvals	RoHS
Operating Temp	-20° C to +40° C
Insulation Class	B, 130° C
Insulation Resistance	100 MegOhms

Standard shaft motor shown.

Description	Length	Mounted Rated Current	Mounted Holding Torque		Winding Ohms mH		Detent Torque		Rotor Inertia		Motor Weight	
			Nm Typ.	oz-in Typ.	±10% @ 20°C Typ.	mNm	oz-in	g cm2	oz-in2	kg	lbs	
(Stack)	"L" Max	Amps										
Single	39.8 mm (1.57 in)	2	0.48	68	1.04	2.2	15	2.1	57	0.31	0.28	0.62
Double	48.3 mm (1.90 in)	2	0.63	89	1.3	2.9	25	3.5	82	0.45	0.36	0.79
Triple	62.8 mm (2.47 in)	2	0.83	120	1.49	3.8	30	4.2	123	0.67	0.6	1.3

\*All standard motors have plug connector. Consult factory for other options.

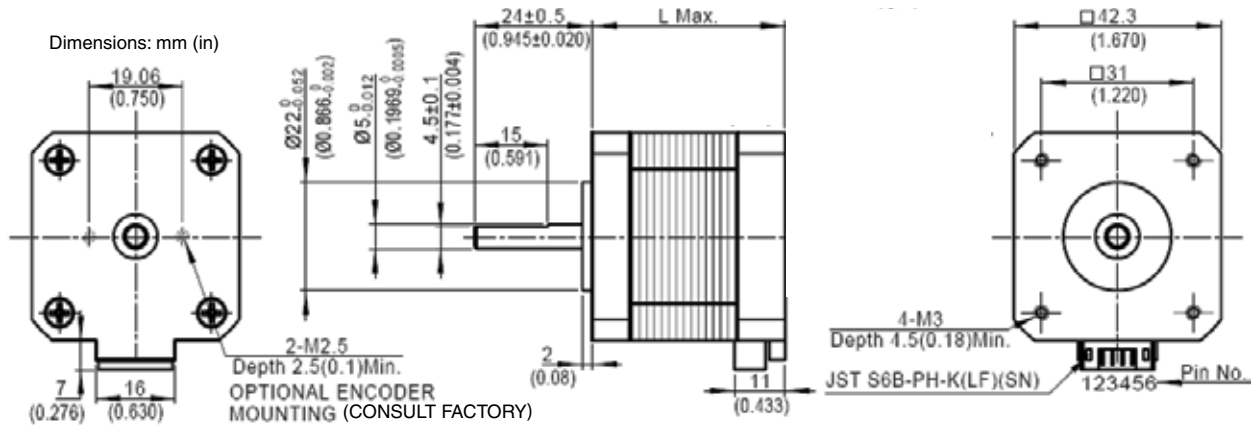

Standard shaft dimensions shown. All other dimensions apply to hollow and extended shaft options.

Dimensions: mm (in)  
4 Lead Connector, PBC Part#6200490  
(Consult factory for optional motor connectors)

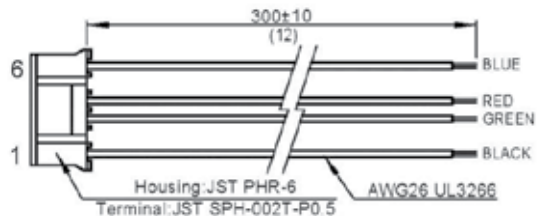

# NEMA 17 Stepper Motor

\*Performance curves apply to continuous duty cycles.  
Consult factory for intermittent cycles or other voltages.

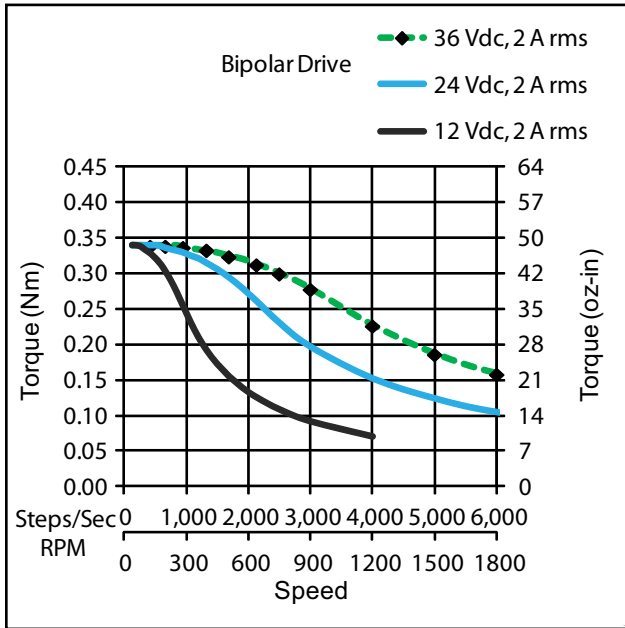

Single Stack

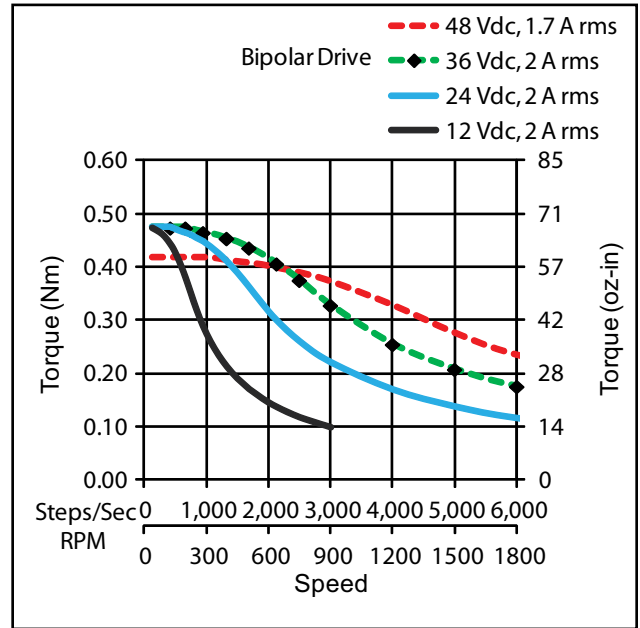

Double Stack

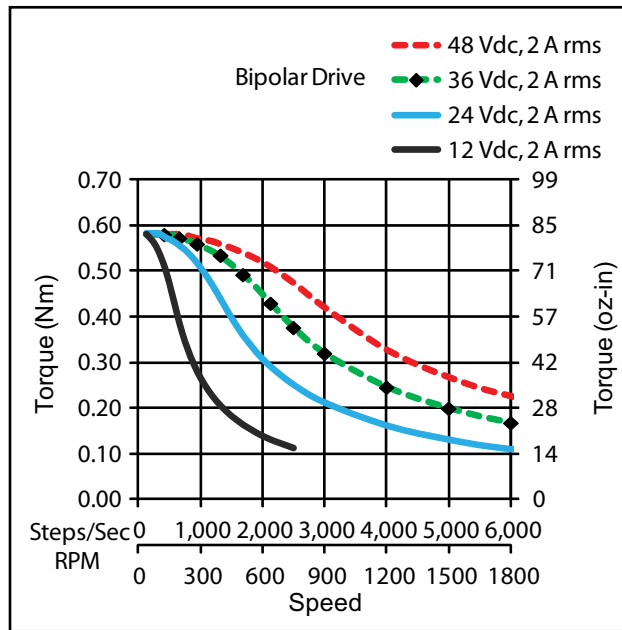

Triple Stack



# Stepper Motor NEMA 23

This document describes mechanical and electrical specifications for PBC Linear stepper motors; including standard, hollow, and extended shaft variations.



Standard shaft motor shown.

Phases	2
Steps/Revolution	200
Step Accuracy	±5%
Shaft Load	20,000 Hours at 1000 RPM
Axial	40 N (9 lbs.) Push 130 N (30 lbs.) Pull
Radial	70 N (15.5 lbs.) At Flat Center
IP Rating	40
Approvals	RoHS
Operating Temp	-20° C to +40° C
Insulation Class	B, 130° C
Insulation Resistance	100 MegOhms

Description	Length	Mounted Rated Current	Mounted Holding Torque	Winding Ohms mH	Detent Torque	Rotor Inertia	Motor Weight
(Stack)	"L" Max	Amps	Nm oz-in Typ. Typ.	±10% @ 20°C Typ.	mNm oz-in	g cm <sup>2</sup> oz-in <sup>2</sup>	kg lbs
Single	55.0 mm (2.17 in)	2.2	1.50 210	1.6 6.9	45 6.4	220 1.2	0.6 1.3
Double	77.0 mm (3.03 in)	3	2.30 330	1.1 4.5	75 11	390 2.1	1 2.2
Power Plus (Triple)	77.0 mm (3.03 in)	3	3.30 470	1.1 3.7	150 21	390 2.1	1.1 2.4

\*All standard motors have plug connector. Consult factory for other options.

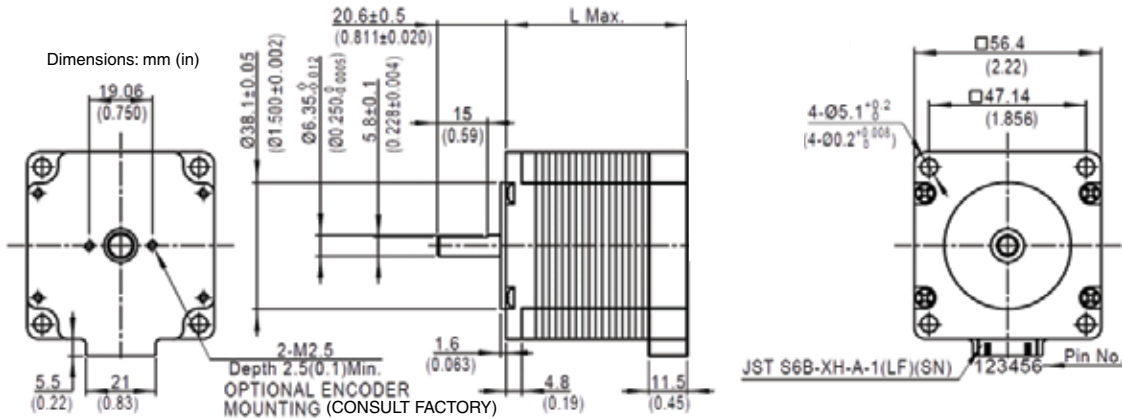

Motor with leads: Lead wire is 22 AWG UL3266, 300 ±10 (12 ±.5) long

Standard shaft dimensions shown. All other dimensions apply to hollow and extended shaft options.

Dimensions: mm (in)  
4 Lead Connector, PBC Part#6200491  
(Consult factory for optional motor connectors)

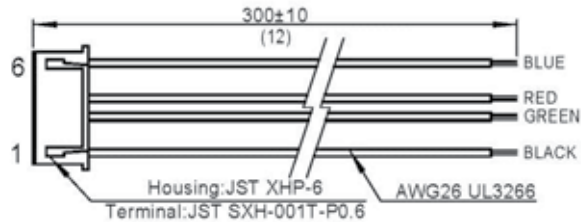

# NEMA 23 Stepper Motor

\*Performance curves apply to continuous duty cycles.  
Consult factory for intermittent cycles or other voltages.

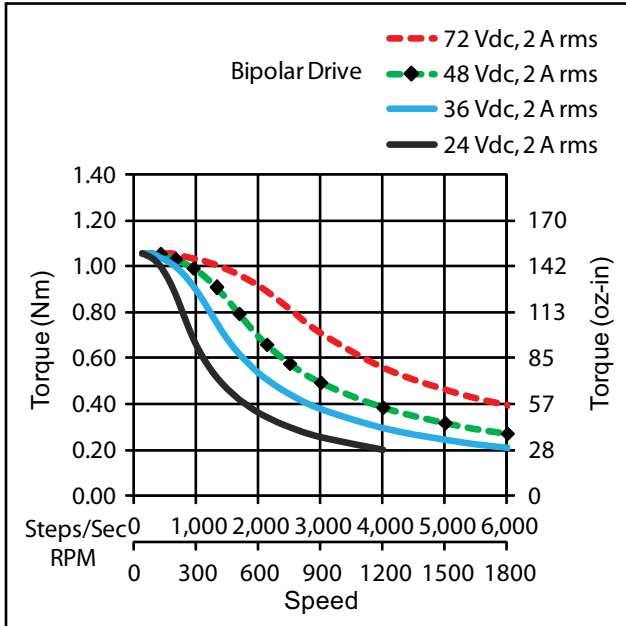

Single Stack

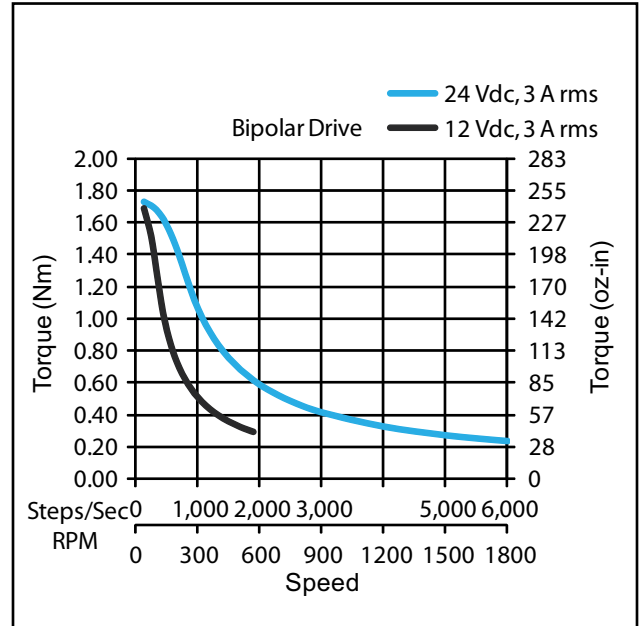

Double Stack

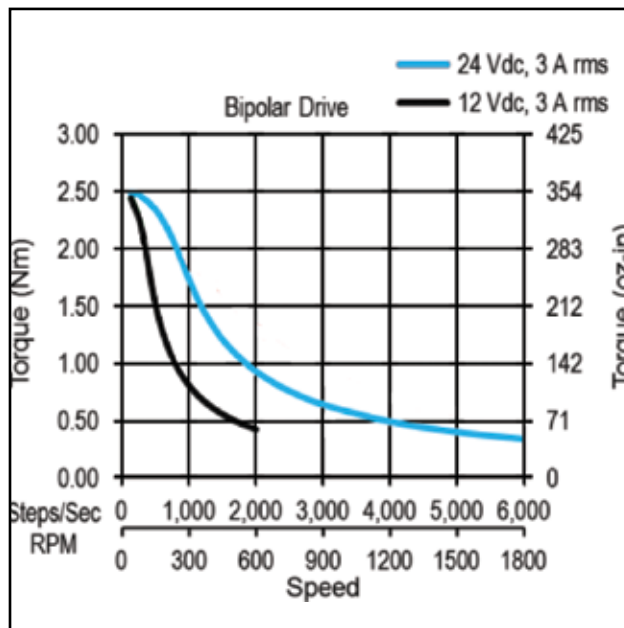

Power Plus (Triple Stack)

