



NEX13120-Q100

12-channel automotive linear LED driver

Rev. 3 — 18 March 2025

Product data sheet

1. General description

NEX13120-Q100 is an AEC-Q100 Grade 1 qualified 12-channel, 40 V high-side LED driver with up to 100 mA output current per channel, PWM and analog dimming support, and MTP for configurable depending on application requirements in Automotive lighting systems.

NEX13120-Q100 supports 8-bit output current with high accuracy from channel to channel and device to device, channels can be used in parallel to support higher current output than 100 mA. The low dropout of the device helps to eliminate the heat generation of the device itself. The device integrates UART over CAN as the digital interface to enable long distance off-board communication, which is a typical scenario for Automotive exterior lighting where different lamp functions are typically located in different PCB boards. NEX13120-Q100 also supports LED open-circuit, short to ground, and single LED short-circuit diagnostics. Additionally, a configurable watchdog automatically sets the part into Fail-Safe states when the CAN bus connection is lost.

NEX13120-Q100 can operate at a junction temperature range from -40 °C to +150 °C in a thermally enhanced 24-pin HTSSOP24 package.

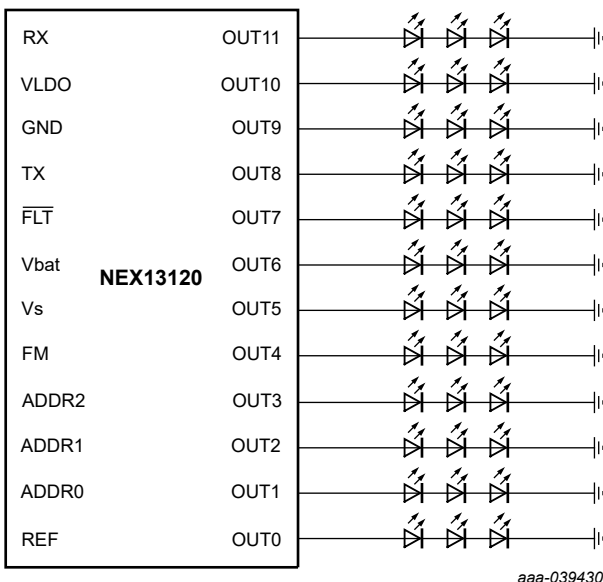

Fig. 1. Typical application

2. Features and benefits

- AEC-Q100 qualified for automotive applications
 - Specified from -40 °C to 125 °C
- Function safety capable
 - Provide documents to support function safety design
- 12-channel precision high-side current output:
 - Vbat: 4.5 V to 36 V and Vs: 3.8 V to 36 V
 - Up to 100 mA channel current per channel
 - 2-bit global, 6-bit independent current setting
 - Current accuracy within $\pm 5\%$ from 18 mA to 100 mA
 - Low voltage drops: 600 mV at 100 mA
 - 12-bit independent PWM dimming
 - Programmable PWM frequency: 50 Hz to 23.4 kHz
 - Linear and exponential dimming method
- Integrated UART interface:
 - Data rate up to 2 Mbit/s
 - Support UART data format
 - Support 27 slave address set by resistor
- Diagnostics and protections:
 - Programmable Fail-Safe state
 - LED open-circuit detection
 - LED short-circuit detection
 - Single-LED short-circuit diagnostic
 - Programmable low-Vs detection
 - Open-drain FLT pin for fault indication
 - Watchdog and CRC for data line
 - MTP ECC check
 - 8-bit ADC for pin voltage measurement
 - Over-temperature protection
- ESD protection:
 - HBM: ANSI/ESDA/JEDEC JS-001 class 2 exceeds 2000 V
 - CDM: ANSI/ESDA/JEDEC JS-002 class C2a exceeds 500 V

3. Applications

- Automotive exterior rear light
- Automotive exterior headlight

4. Ordering information

Table 1. Ordering information

Type number	Package			Version
	Temperature range	Name	Description	
NEX13120PC-Q100	-40 °C to +125 °C	HTSSOP24	Thermal enhanced thin shrink small outline package; 24 leads; body size: 7.8 mm x 4.4 mm x 1.2 mm	SOT8083-1

5. Device comparison

Table 2. Device Comparison

Type number	Output current (I_{OUT})
NEX13120PC-Q100	12-channel UART+FS capable
NEX13120FPC-Q100	12-channel UART+FS compliant

6. Marking

Table 3. Marking

Type number	Marking code
NEX13120PC-Q100	N13120

7. Application block diagram

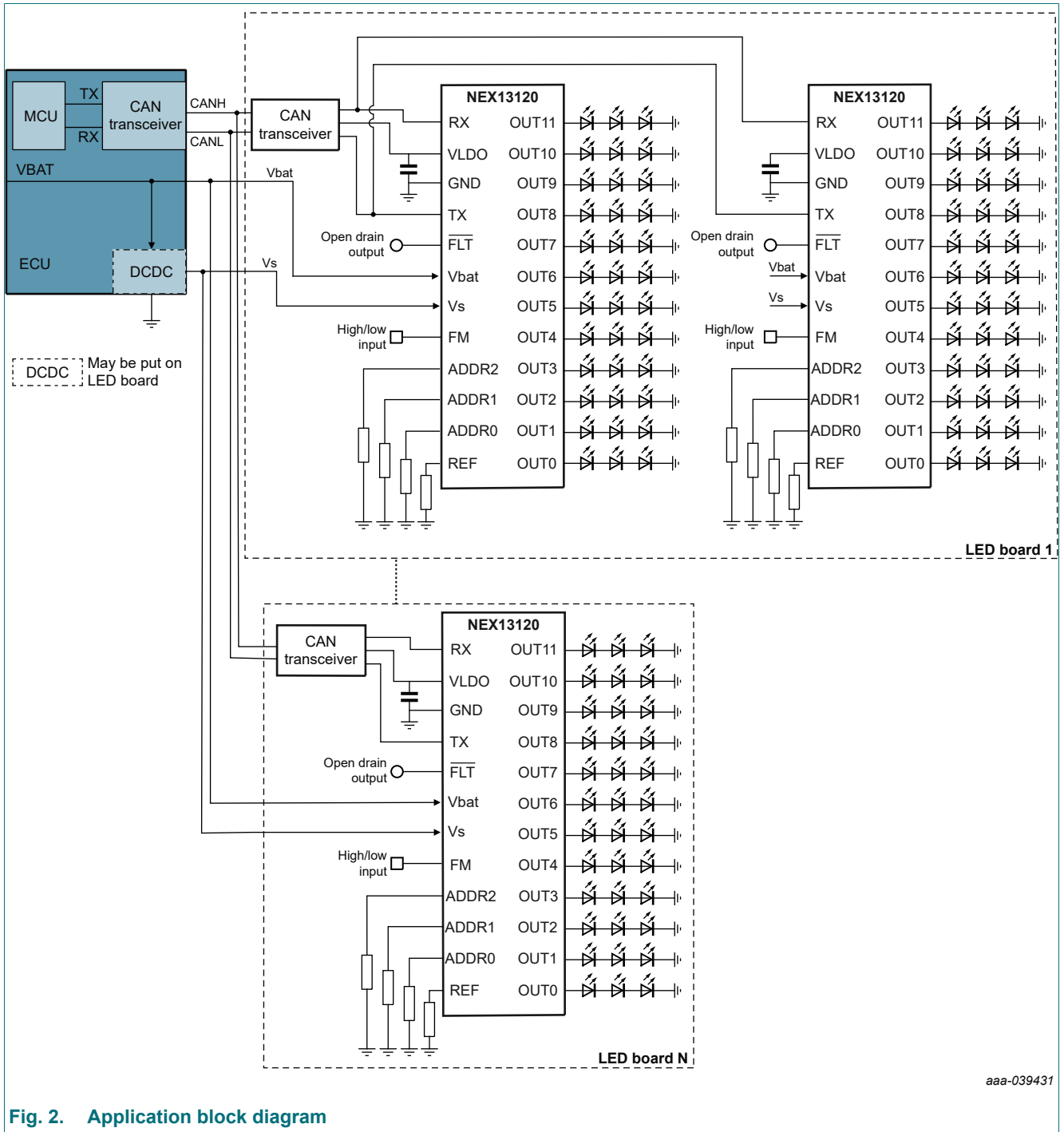

Fig. 2. Application block diagram

8. Pinning information

8.1. Pinning

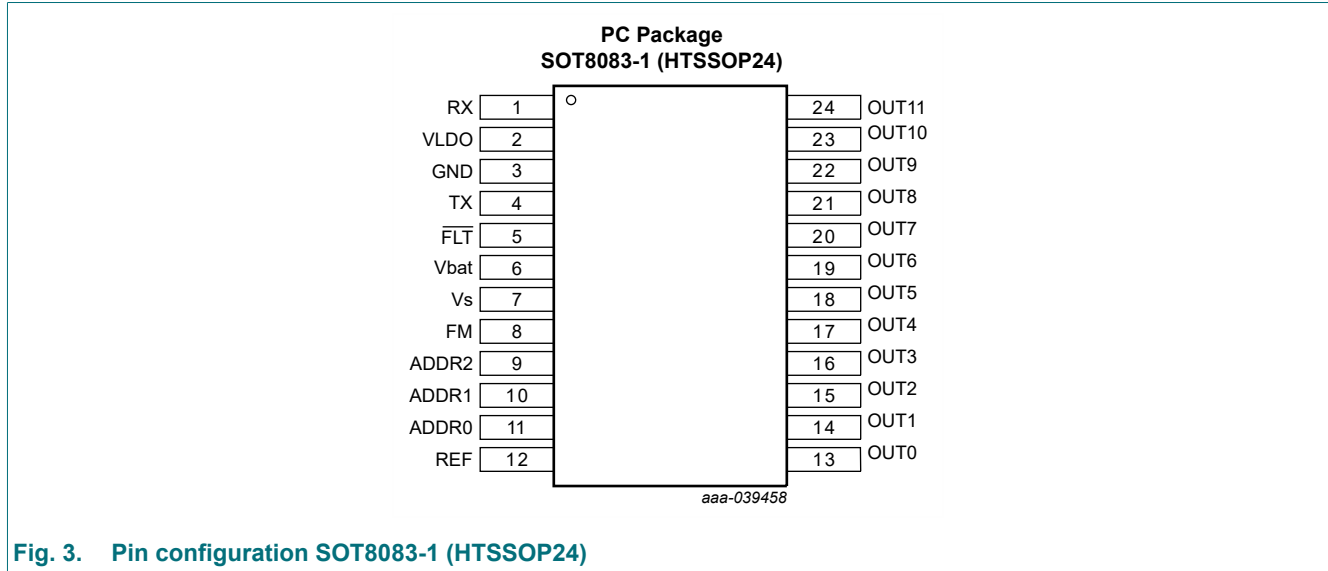

Fig. 3. Pin configuration SOT8083-1 (HTSSOP24)

8.2. Pin description

Table 4. Pin description

Symbol	Pin	I/O	Description
RX	1	I	UART RX over CAN physical layer
VLDO	2	Power	output of internal 5 V LDO
GND	3	GND	device ground
TX	4	O	UART TX over CAN physical layer
FLT	5	I/O	open-drain fault/error output
Vbat	6	I	power supply for internal circuit
Vs	7	I	power supply for current output channels
FM	8	I	Fail-Safe state selection; 0: Fail-Safe mode 0; 1: Fail-Safe mode 1
ADDR2	9	I	device address 2
ADDR1	10	I	device address 1
ADDR0	11	I	device address 0
REF	12	I/O	device reference current setting, MTP programming chip-selection input
OUT0 to OUT11	13 to 24	O	current output channel 0 to 11

9. Limiting values

Table 5. Limiting values

In accordance with the Absolute Maximum Rating System (IEC 60134). Voltages are referenced to GND (ground = 0 V).

Symbol	Parameter	Conditions	Min	Max	Unit
V _I	input voltage	pins Vbat, Vs	-0.3	45	V
		pin REF, ADDRn	-0.3	5.5	V
V _O	output voltage	pins OUTn	-0.3	V _s + 0.3	V
		pin VLDO	-0.3	5.5	V
V _{I/O}	I/O voltage	pin FM	-0.3	V _s + 0.3	V
		pin FLT	-0.3	22	V
		pins RX, TX	-0.3	5.5	V
T _j	junction temperature		-40	150	°C
T _{amb}	ambient temperature		-40	125	°C
T _{stg}	Storage temperature		-65	150	°C
ESD					
V _{ESD}	ESD voltage	Human Body Model (HBD) for all pins, per AECQ100-002	-2000	+2000	V
		Charged device model (CDM), per AEC Q100-011			
		corner pins (1, 12, 13 and 24)	-750	+750	V
		all pins	-500	+500	V

10. Recommended operating conditions

Table 6. Recommended operating conditions

Symbol	Parameter	Conditions	Min	Typ	Max	Unit
V _I	input voltage	pin Vbat; device supply voltage	4.5	-	36	V
		pin Vs; power supply for output current channel	3.8	-	36	V
I _O	output current	pins OUTn; channel output current	-	-	100	mA
V _I	input voltage	pin FM; external Fail-Safe selection input	0	-	V _s	V
V _{I/O}	input/output voltage	pin TX; UART TX output	0	-	5	V
		pin RX; UART RX input	0	-	5	V
V _{VLDO}	VLDO voltage	pin VLDO; internal 5 V VLDO output	0	-	5	V
I _{VLDO}	VLDO current	pin VLDO; current capability	0	-	80	mA
V _I	input voltage	pins ADDRn; device address selection	0	-	5	V
V _{I/O}	input/output voltage	pin REF; current reference setting	0	-	5	V
		pin FLT; fault/error feedback open-drain output	0	-	20	V
F _{CLK}	UART baud rate		0.1	-	2	Mbps
D _{sync}	synchronization pulse duty cycle		45	50	55	%
T _j	junction temperature		-40	-	150	°C
T _{amb}	ambient temperature		-40	25	125	°C

11. Thermal information

Table 7. Thermal information

Symbol	Parameter	SOT8083-1	Unit
$R_{\theta JA}$	junction-to-ambient thermal resistance	25.8	°C/W
$R_{\theta JC(TOP)}$	junction-to-case (top) thermal resistance	29.2	°C/W
$R_{\theta JB}$	junction-to-board thermal resistance	11.7	°C/W
Ψ_{JT}	junction-to-top char parameter	3.6	°C/W

12. Electrical characteristics

Table 8. Static characteristics

At recommended operating conditions. Voltages are referenced to GND (ground = 0 V).

Symbol	Parameter	Conditions	-40 °C to +125 °C			Unit
			Min	Typ	Max	
Bias						
$V_{(Vbat)}$	operating input voltage range		4.5	12	36	V
$I_{q(Vbat)}$	quiescent current, all-channels ON	$V_{bat} = 12\text{ V}$; $R_{REF} = 8.45\text{ k}\Omega$; all outputs ON; REFRANGE = 11b; PWM duty = 0	-	8	9	mA
	quiescent current, all-channels OFF	$V_{bat} = 12\text{ V}$; $R_{REF} = 8.45\text{ k}\Omega$; REFRANGE = 11b; all outputs OFF	-	8	9	mA
$I_{q(Vs)}$	quiescent current, all-channels ON	$V_{bat} = 12\text{ V}$; $V_s = 12\text{ V}$; $R_{REF} = 8.45\text{ k}\Omega$; REFRANGE = 11b; PWM Duty = 0; all outputs ON	-	8	-	mA
	quiescent current, all-channels-off	$V_{bat} = 12\text{ V}$; $V_s = 12\text{ V}$; $R_{REF} = 8.45\text{ k}\Omega$; REFRANGE = 11b; all outputs OFF	-	20	30	μA
$I_{fault(Vbat)}$	quiescent current, Fail-Safe state fault mode	$V_s = 12\text{ V}$; Fail-Safe state; all outputs OFF; $\overline{FLT} = \text{LOW}$	-	8	9	mA
$I_{fault(Vs)}$	quiescent current, Fail-Safe state fault mode	$V_s = 12\text{ V}$; Fail-Safe state; all outputs OFF; $\overline{FLT} = \text{LOW}$	-	20	30	μA
$I_{LKG(Vs)}$	V_s leakage current	$V_s = 36\text{ V}$; $V_{bat} = 0\text{ V}$	-	-	85	μA
$V_{(Vbat_POR_rise)}$	V_{bat} power-on-reset rising threshold		4	4.2	4.45	V
$V_{(Vbat_POR_fall)}$	V_{bat} power-on-reset falling threshold		3.8	4	4.2	V
$V_{O(VLDO)}$	VLDO output voltage	$V_{bat} > 5.6\text{ V}$; $I_{(VLDO)} = 40\text{ mA}$	4.65	5	5.25	V
$I_{O(VLDO)}$	VLDO output current capability		80	-	-	mA
$I_{(VLDO_limit)}$	VLDO output current limit		110	-	-	mA
$V_{(VLDO_POR_rise)}$	VLDO power-on-reset rising threshold		2.75	3	3.25	V
$V_{(VLDO_POR_fall)}$	VLDO power-on-reset falling threshold		2.45	2.75	3	V
$V_{(VLDO_OV_rise)}$	VLDO overvoltage rising threshold [1]		-	5.7	-	V
$V_{(VLDO_OV_fall)}$	VLDO overvoltage falling threshold [1]		-	5.5	-	V
C_{VLDO}	supported VLDO loading capacitance		1	-	10	μF
f_{osc}	internal oscillator frequency		-	24	-	MHz

Symbol	Parameter	Conditions	-40 °C to +125 °C			Unit
			Min	Typ	Max	
FLT						
V _{IH(FLT)}	logic High voltage, $\overline{\text{FLT}}$		2	-	-	V
V _{IL(FLT)}	logic Low voltage, $\overline{\text{FLT}}$		-	-	0.7	V
I _{pd(FLT)}	$\overline{\text{FLT}}$ pull-down current capability	V _(FLT) = 0.4 V	3	5.5	9	mA
I _{LKG(FLT)}	$\overline{\text{FLT}}$ leakage current	V _(FLT) = 5 V	-	-	1	μA
UART interface						
V _{IL(RX)}	input logic low voltage, RX		-	-	0.7	V
V _{IH(RX)}	input logic high voltage, RX		2	-	-	V
V _{OL(TX)}	low-level output voltage TX,	I _{sink} = 5 mA	0	-	0.47	V
V _{OH(TX)}	high-level output voltage TX,	I _{source} = 5 mA; V _{pull-up} = 5 V	4.5	-	5	V
I _{LKG(TX-RX)}	TX, RX leakage current	V _{RX} = 5 V; V _{TX} = 5 V	-1	-	1	μA
ADDRESS, FS						
V _{IL(FS)}	input logic low voltage, FS		-	-	0.7	V
V _{IH(FS)}	input logic high voltage, FS		2	-	-	V
V _{IL(ADDRn)}	logic low voltage ADDR2, ADDR1, ADDR0		-	-	0.7	V
V _{IM(ADDRn)}	middle logic voltage ADDR2, ADDR1, ADDR0		0.86	-	1.6	V
V _{IH(ADDRn)}	logic high voltage ADDR2, ADDR1, ADDR0		2	-	-	V
R _{PD(FS)}	internal pull-down resistance, FS		-	100	-	kΩ
ADC[1]						
DNL	differential non linearity		-1	-	1	LSB
INL	differential non linearity		-2	-	2	LSB
OUTPUT DRIVERS						
f _{PWM}	PWM dimming frequency range	CONF_PWMSLOW = 0	0.2	-	25.3	kHz
		CONF_PWMSLOW = 1	0.05	-	5.86	kHz
ΔI _(OUT_d2d)	device-to-device accuracy ΔI _(OUT_d2d) = 1 - I _{avg(OUT)} /I _{nom(OUT)}	R _{REF} = 6.34 kΩ; REFRANGE = 11b; DC = 63; I _{OUT} = 100 mA	-5	0	5	%
		R _{REF} = 8.45 kΩ; REFRANGE = 11b; DC = 63; I _{OUT} = 75 mA	-5	0	5	%
		R _(REF) = 8.45 kΩ; REFRANGE = 10b; DC = 63; I _{OUT} = 37.5 mA	-5	0	5	%
		R _{REF} = 8.45 kΩ; REFRANGE = 01b; DC = 63; I _{OUT} = 18.75 mA	-6	0	6	%
ΔI _(OUT_c2c)	channel-to-channel accuracy ΔI _(OUT_c2c) = 1 - I _(OUTn) /I _{avg(OUT)}	R _{REF} = 6.34 kΩ; REFRANGE = 11b; DC = 63; I _{OUT} = 100 mA	-5	0	5	%
		R _{REF} = 8.45 kΩ; REFRANGE = 11b; DC = 63; I _{OUT} = 75 mA	-5	0	5	%
		R _{REF} = 8.45 kΩ; REFRANGE = 10b; DC = 63; I _{OUT} = 37.5 mA	-5	0	5	%
		R _{REF} = 8.45 kΩ; REFRANGE = 01b; DC = 63; I _{OUT} = 18.75 mA	-6	0	6	%

Symbol	Parameter	Conditions	-40 °C to +125 °C			Unit
			Min	Typ	Max	
$V_{(OUT_drop)}$	output dropout voltage	$R_{REF} = 8.45 \text{ k}\Omega$; REFRANGE = 11b; DC = 38; $I_{OUT} = 45 \text{ mA}$	300	430	590	mV
		$R_{REF} = 8.45 \text{ k}\Omega$; REFRANGE = 11b; DC = 63; $I_{OUT} = 75 \text{ mA}$	360	490	730	mV
		$R_{REF} = 6.34 \text{ k}\Omega$; REFRANGE = 11b; DC = 63; $I_{OUT} = 100 \text{ mA}$	400	600	860	mV
R_{REF}			5	-	50	k Ω
C_{REF}			0	-	4.7	nF
V_{REF}			-	1.235	-	V
$K_{(REF_11)}$		REFRANGE = 11b	-	512	-	-
$K_{(REF_10)}$		REFRANGE = 10b	-	256	-	-
$K_{(REF_01)}$		REFRANGE = 01b	-	128	-	-
$K_{(REF_00)}$		REFRANGE = 00b	-	64	-	-
$I_{(REF_OPEN_th)}$			4	12	20	μA
$V_{(REF_SHORT_th)}$			0.4	0.6	0.8	V
DIAGNOSTICS						
$V_{(Vs_th_rise)}$	V_s undervoltage rising threshold		2.5	2.75	2.9	V
$V_{(Vs_th_fall)}$	V_s undervoltage falling threshold		2.3	2.55	2.7	V
$V_{(Vs_th_hyst)}$	V_s undervoltage hysteresis		-	200	-	mV
$V_{(OPEN_th_rise)}$	LED open rising threshold, AUTOSS=0	$V_{(Vs)} - V_{(OUTn)}$	200	240	325	mV
$V_{(OPEN_th_rise)}$	LED open rising threshold, AUTOSS=1	$V_{(Vs)} - V_{(OUTn)}$	230	300	445	mV
$V_{(OPEN_th_fall)}$	LED open falling threshold	$V_{(Vs)} - V_{(OUTn)}$	140	400	450	mV
$V_{(OPEN_th_hyst)}$	LED open hysteresis		-	100	-	mV
$V_{(SG_th_rise)}$	short to GND rising threshold		0.8	0.9	1	V
$V_{(SG_th_fall)}$	short to GND falling threshold		1.05	1.2	1.3	V
$V_{(SG_th_hyst)}$	short to GND hysteresis		-	0.3	-	V
MTP						
$N_{(MTP)}$	number of programming cycles	VLDO = 5 V	1000	-	-	-
Temperature^[1]						
$T_{(PRETSD)}$	pre-thermal warning threshold		-	135	-	$^{\circ}\text{C}$
$T_{(PRETSD_HYS)}$	pre-thermal warning hysteresis		-	5	-	$^{\circ}\text{C}$
$T_{(TSD1)}$	over-temperature protection threshold		-	175	-	$^{\circ}\text{C}$
$T_{(TSD2)}$	over-temperature shutdown threshold		-	185	-	$^{\circ}\text{C}$
$T_{(TSD1_HYS)}$	over-temperature protection hysteresis		-	15	-	$^{\circ}\text{C}$
$T_{(TSD2_HYS)}$	over-temperature shutdown hysteresis		-	15	-	$^{\circ}\text{C}$

[1] Guaranteed by bench test, not fully tested in production.

Table 9. Timing requirement

Symbol	Parameter	Conditions	-40 °C to +125 °C			Unit
			Min	Typ	Max	
t _(ODPW)	diagnostics pulse-width, ODPW = 0h		-	100	-	µs
t _(CONV)	time needed to complete one AD conversion		-	55	-	µs
t _(retry)	fault retry timer		-	10	-	ms

13. Typical characteristics

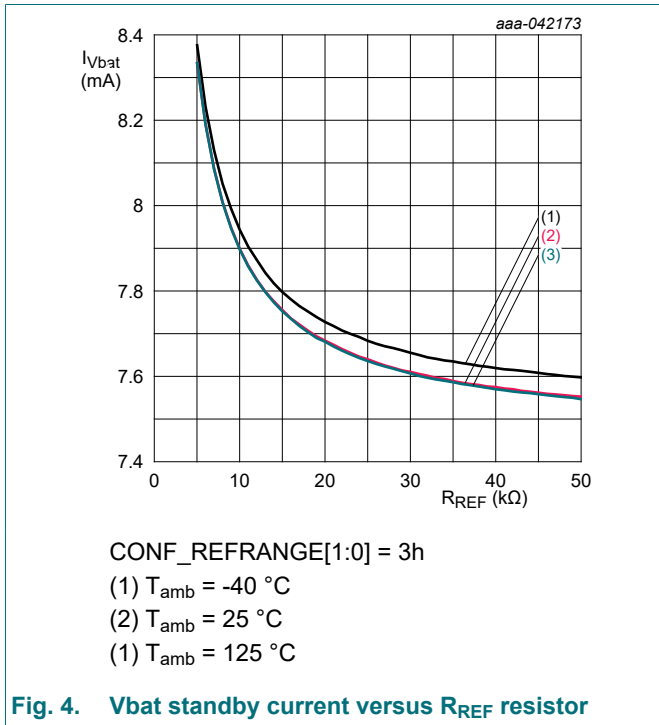

Fig. 4. Vbat standby current versus R_{REF} resistor

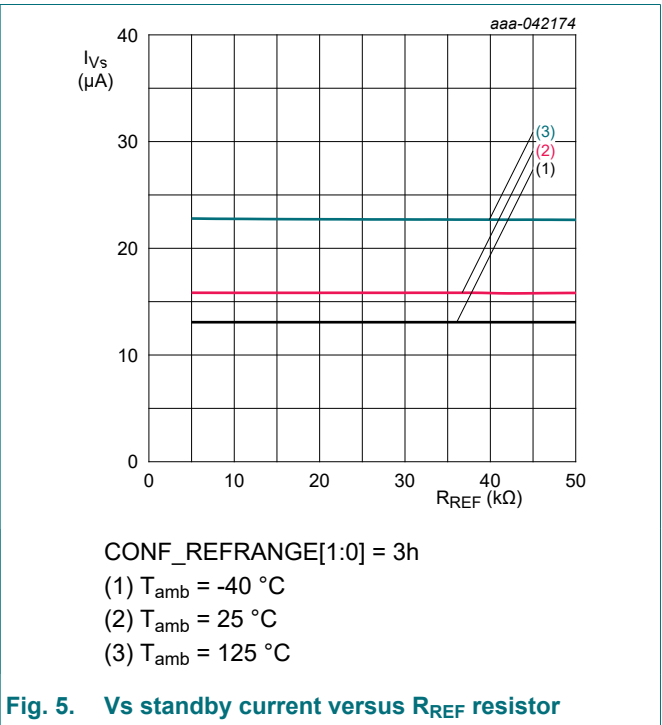
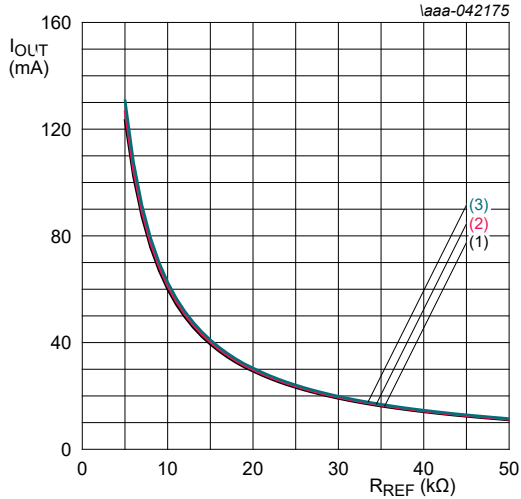
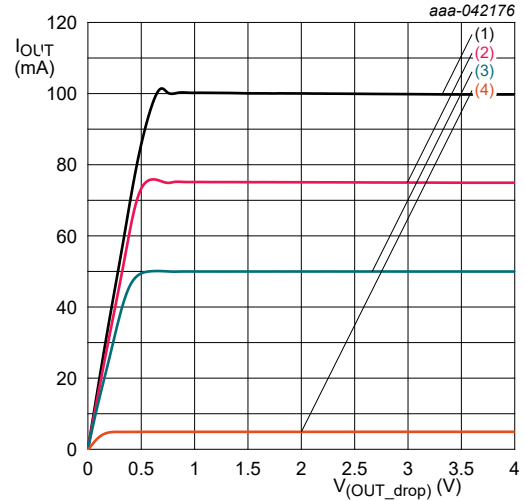

Fig. 5. Vs standby current versus R_{REF} resistor



CONF_IOUTx[5:0] = 3Fh
 CONF_REFRANGE[1:0] = 3h
 (1) $T_{amb} = -40\text{ °C}$
 (2) $T_{amb} = 25\text{ °C}$
 (3) $T_{amb} = 125\text{ °C}$

Fig. 6. Output full-range current versus R_{REF} Resistor



CONF_REFRANGE[1:0] = 3h
 (1) $I_{OUT} = 100\text{ mA}$
 (2) $I_{OUT} = 75\text{ mA}$
 (3) $I_{OUT} = 50\text{ mA}$
 (4) $I_{OUT} = 5\text{ mA}$

Fig. 7. Output current versus dropout voltage

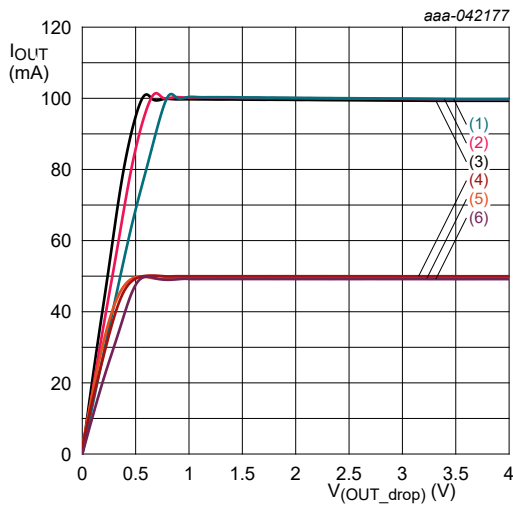

$R_{REF} = 6.34\text{ k}\Omega$ & $12.6\text{ k}\Omega$
 CONF_REFRANGE[1:0] = 3h
 (1) $I_{OUT} = 100\text{ mA}$; $T_{amb} = 125\text{ °C}$
 (2) $I_{OUT} = 100\text{ mA}$; $T_{amb} = 25\text{ °C}$
 (3) $I_{OUT} = 100\text{ mA}$; $T_{amb} = -40\text{ °C}$
 (4) $I_{OUT} = 50\text{ mA}$; $T_{amb} = 125\text{ °C}$
 (5) $I_{OUT} = 50\text{ mA}$; $T_{amb} = -40\text{ °C}$
 (6) $I_{OUT} = 50\text{ mA}$; $T_{amb} = 25\text{ °C}$

Fig. 8. Output current versus dropout voltage

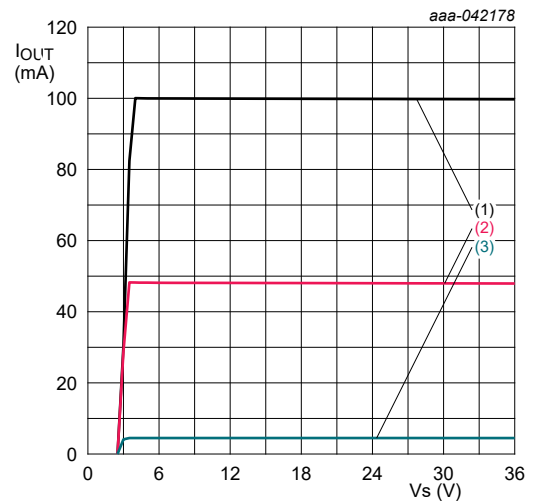

CONF_REFRANGE[1:0] = 3h
 (1) $I_{OUT} = 100\text{ mA}$
 (2) $I_{OUT} = 50\text{ mA}$
 (3) $I_{OUT} = 5\text{ mA}$

Fig. 9. Output current versus dropout voltage

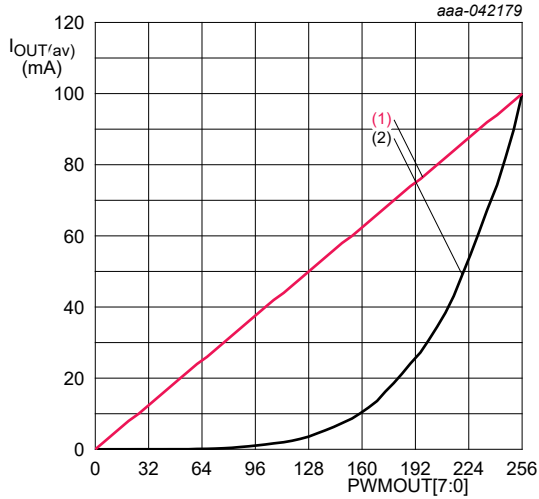

CONF_EXPEN = 0 & 1
 CONF_IOUTx[5:0] = 3Fh
 (1) CONF_EXPEN = 0
 (2) CONF_EXPEN = 1

Fig. 10. Average current versus PWMOUT[7:0]

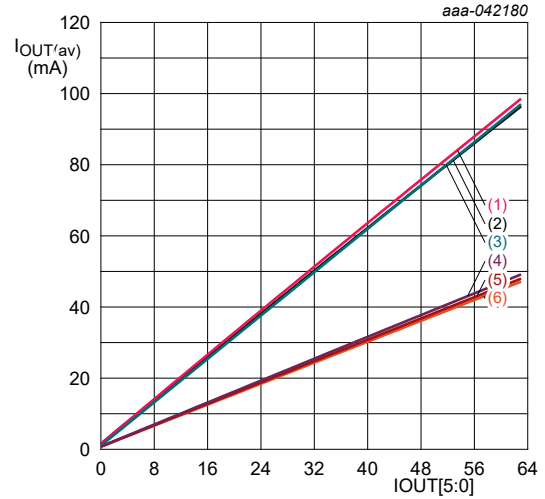

$R_{REF} = 6.34 \text{ k}\Omega$ & $12.6 \text{ k}\Omega$
 CONF_REFRANGE[1:0] = 3h
 (1) $I_{OUT} = 100 \text{ mA}$; $T_{amb} = 25 \text{ }^\circ\text{C}$
 (2) $I_{OUT} = 100 \text{ mA}$; $T_{amb} = -40 \text{ }^\circ\text{C}$
 (3) $I_{OUT} = 100 \text{ mA}$; $T_{amb} = 125 \text{ }^\circ\text{C}$
 (4) $I_{OUT} = 50 \text{ mA}$; $T_{amb} = 125 \text{ }^\circ\text{C}$
 (5) $I_{OUT} = 50 \text{ mA}$; $T_{amb} = 25 \text{ }^\circ\text{C}$
 (6) $I_{OUT} = 50 \text{ mA}$; $T_{amb} = -40 \text{ }^\circ\text{C}$

Fig. 11. Output DC current versus IOU[5:0]

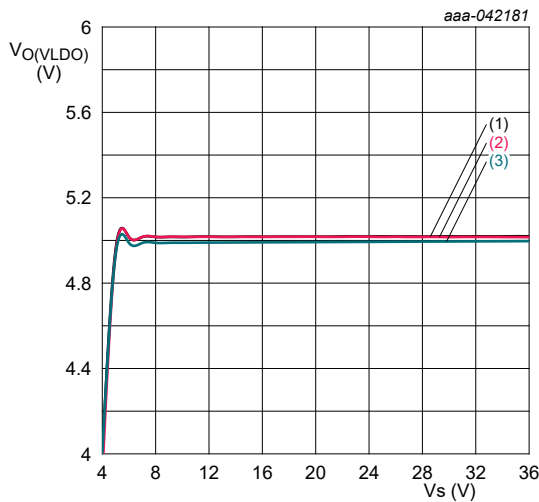

(1) $T_{amb} = -40 \text{ }^\circ\text{C}$
 (2) $T_{amb} = 25 \text{ }^\circ\text{C}$
 (3) $T_{amb} = 125 \text{ }^\circ\text{C}$

Fig. 12. LDO output line regulation

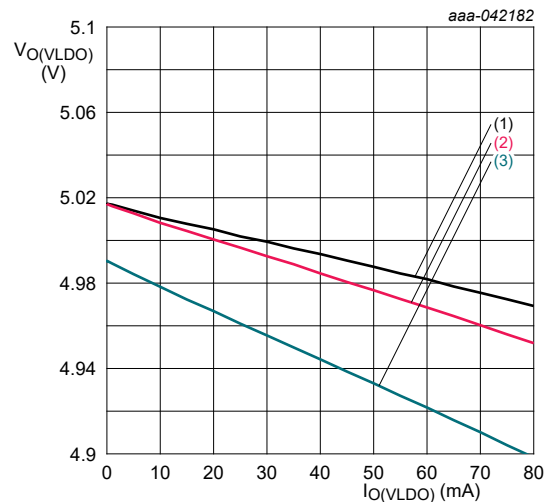

(1) $T_{amb} = -40 \text{ }^\circ\text{C}$
 (2) $T_{amb} = 25 \text{ }^\circ\text{C}$
 (3) $T_{amb} = 125 \text{ }^\circ\text{C}$

Fig. 13. LDO output load regulation

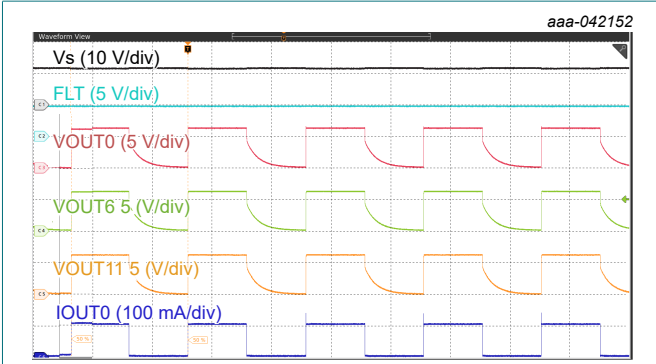

Fig. 14. PWM dimming at 50 Hz

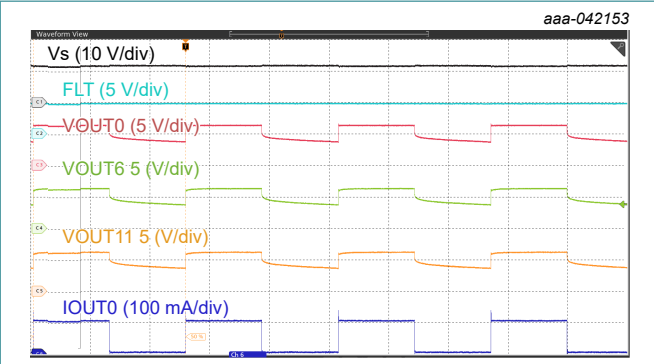

Fig. 15. PWM dimming at 2000 Hz

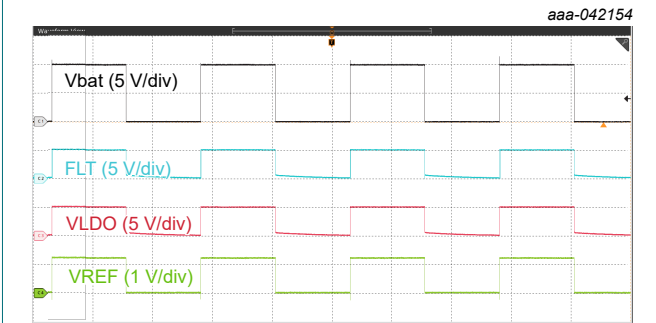

Fig. 16. Vbat start-up and shutdown

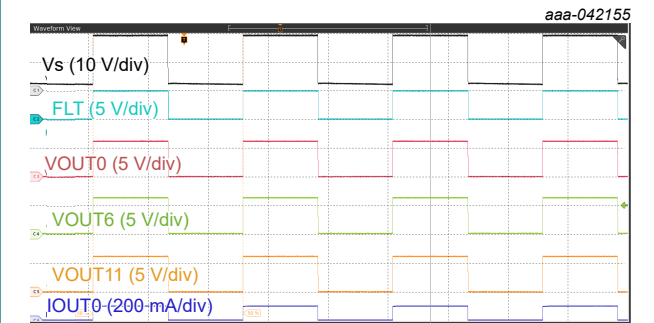

Fig. 17. Vs start-up and shutdown

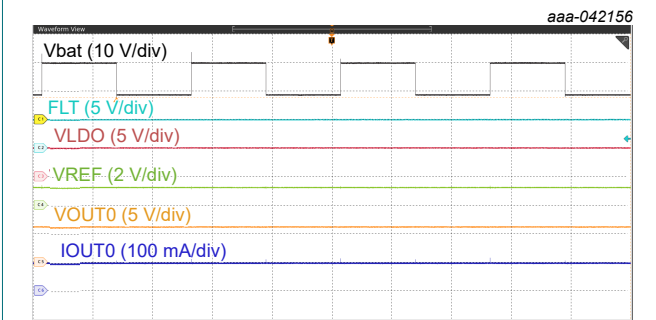

Fig. 18. Vbat transient

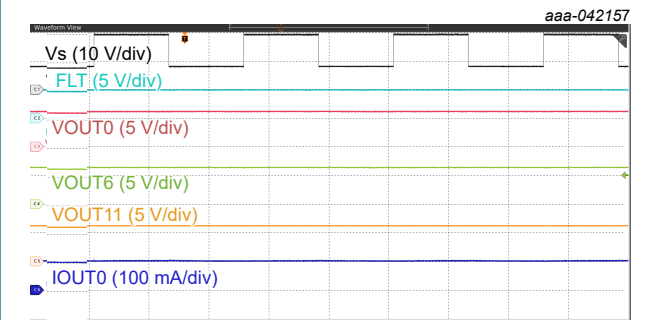

Fig. 19. Vs transient

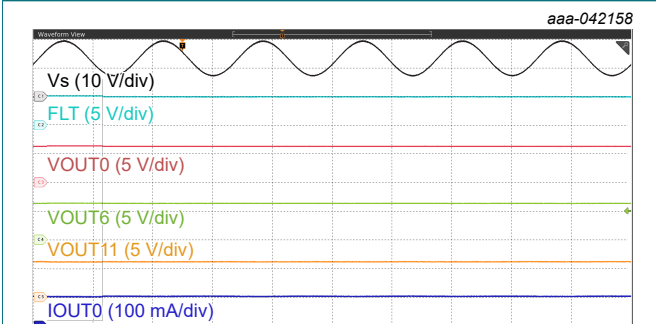

Fig. 20. Superimposed alternating voltage 15 Hz

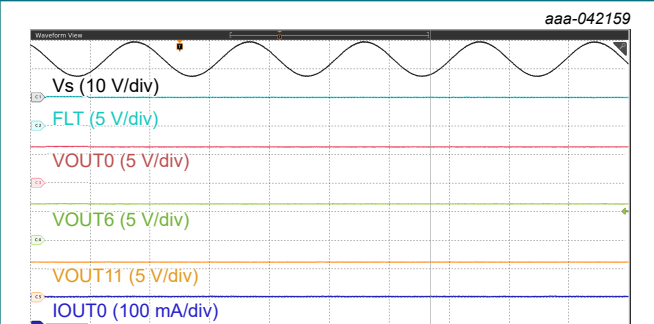

Fig. 21. Superimposed alternating voltage 1 kHz

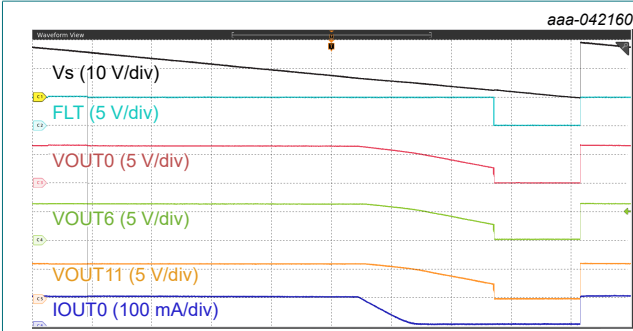

Fig. 22. Slow decrease and quick increase of supply voltage

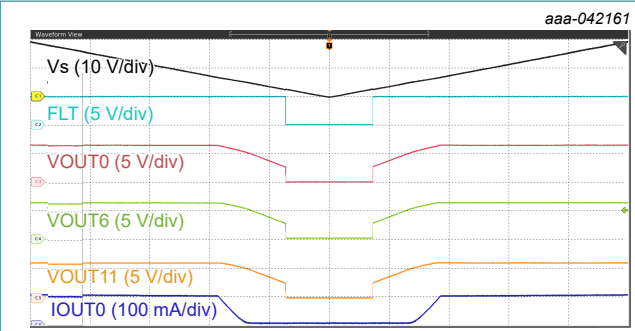

Fig. 23. Slow decrease and slow increase of supply voltage

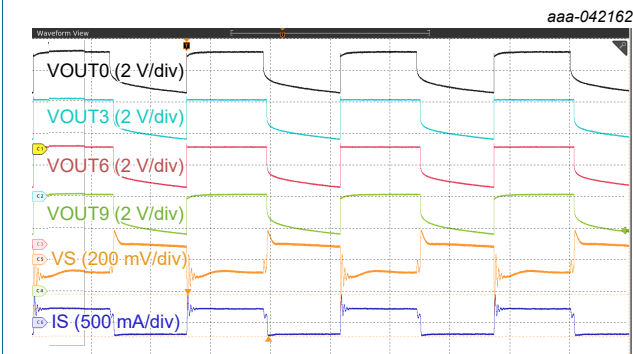

Fig. 24. Phase shift disable

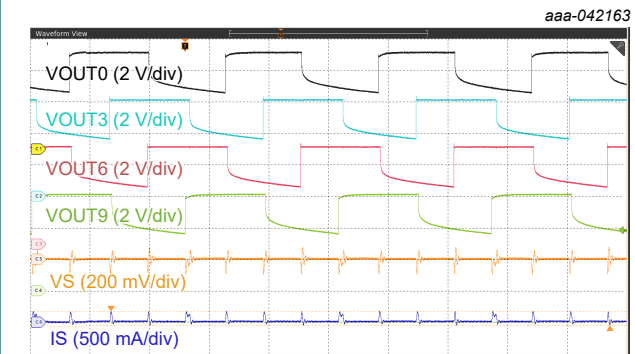

Fig. 25. Phase shift enable

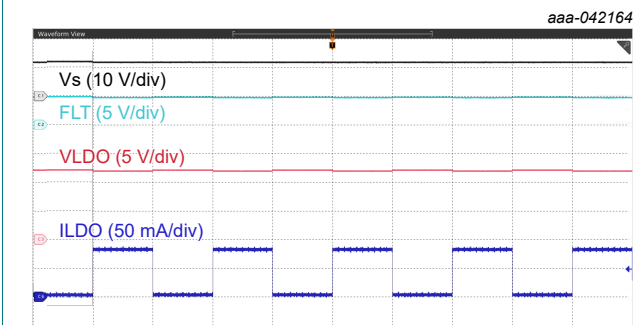

Fig. 26. LDO output load transient

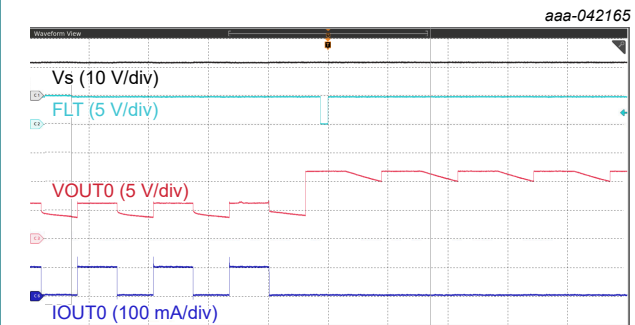

Fig. 27. LED open-circuit detection in normal mode

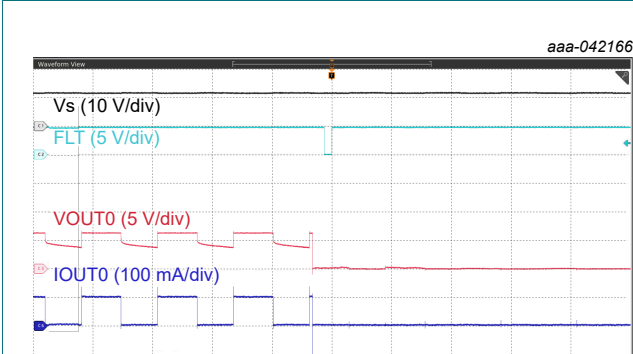

Fig. 28. LED short-circuit detection in normal mode

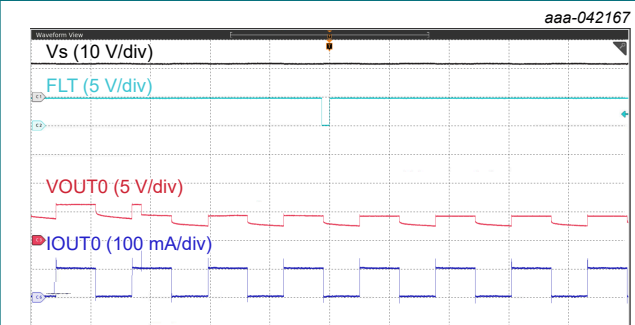

Fig. 29. Single-LED short circuit detection in normal mode

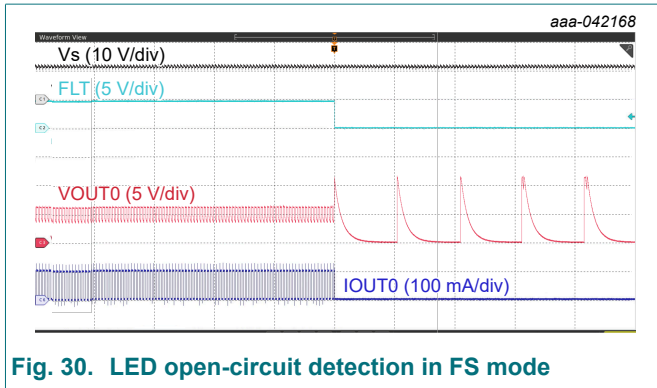

Fig. 30. LED open-circuit detection in FS mode

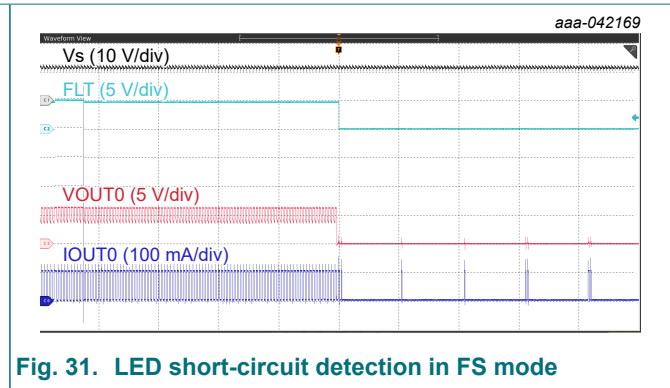

Fig. 31. LED short-circuit detection in FS mode

14. Detailed description

14.1. Overview

The NEX13120-Q100 is an automotive 12-channel LED driver equipped with a UART interface to meet the growing demand for individual control of each LED string. Each channel supports both analog dimming and pulse-width modulation (PWM) dimming, configurable via the UART. The internal MTP (Multi-time Programming memory) enables users to set configurations in the event of communication loss, ensuring compliance with system-level safety requirements.

The integrated UART interface is compliant with physical layer transceiver such as CAN or LIN transceivers. It can support off board communication with the transition of CAN or LIN transceivers.

Each output channel serves as a constant current source, allowing for individually programmable current outputs and PWM duty cycles. The device includes various diagnostic features, such as LED open-circuit, short-circuit, and single-LED short-circuit detection. Additionally, the on-chip analog-to-digital converter (ADC) enables real-time monitoring of output conditions.

To enhance robustness, NEX13120-Q100 integrates Fail-Safe state machine that automatically switches to Fail-Safe states in case of communication loss, such as MCU failure. Users can program Fail-Safe settings using the MTP, allowing for different configurations in the event of output failure, such as one-fails-all-fail or one-fails-others-on. Each channel can be independently programmed to either remain on or off during Fail-Safe states.

The Fail-Safe state machine also permits the system to operate with pre-programmed MTP settings without the presence of a controller, enabling stand-alone operation. The microcontroller can access each device through the UART interface, allowing full control over the device and LEDs by setting and reading back registers. All MTPs are pre-programmed with default values, and Nexperia recommends that users program the MTP at the end of the production line for application-specific settings and Fail-Safe configurations.

14.2. Function block diagram

The NEX13120-Q100 function block diagram is shown below:

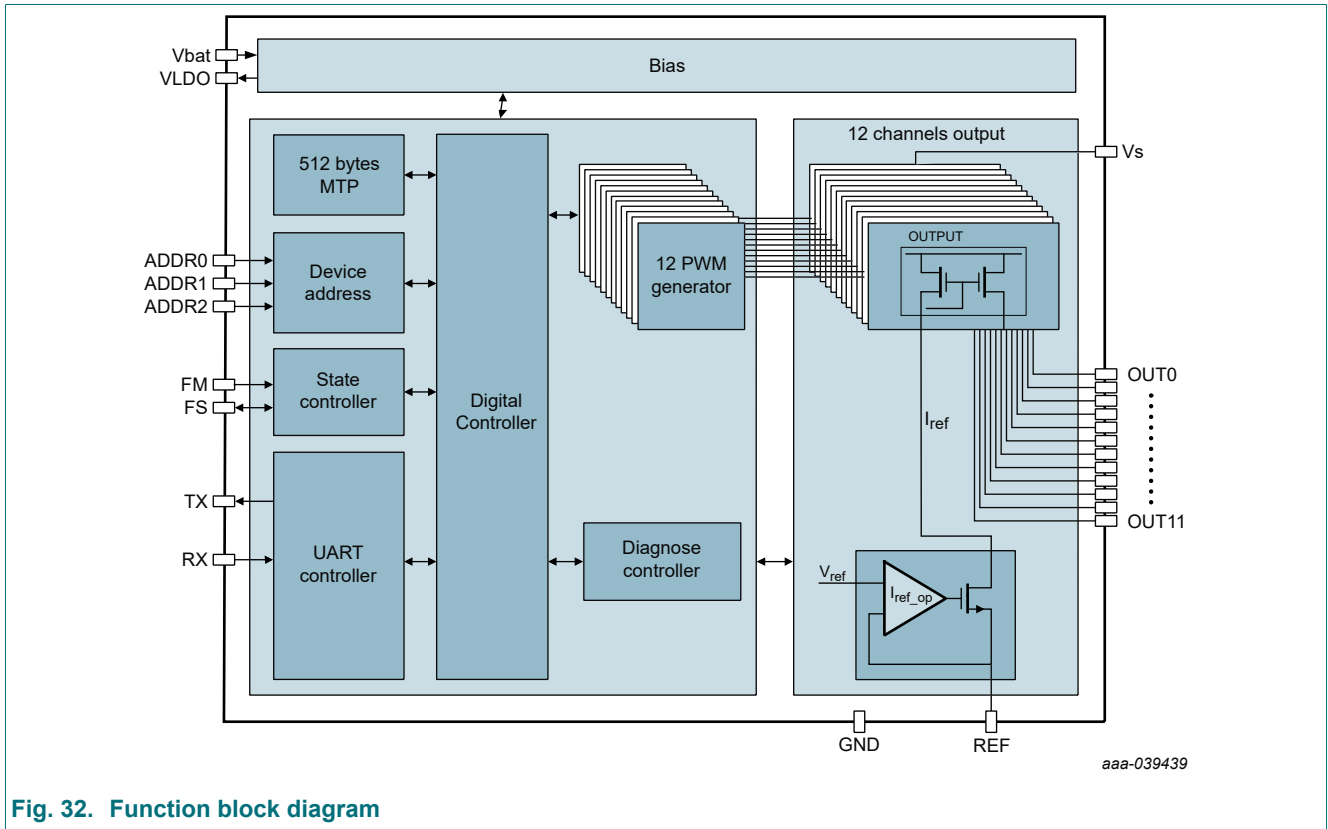

Fig. 32. Function block diagram

14.3. Feature description

14.3.1. Device bias and power

Power supply (Vbat)

The NEX13120-Q100 is AECQ-100 qualified for automotive applications. The power input to the device through Vbat pin can be low to 4.5 V and up to 36 V for automotive battery directly powered systems. All the internal analog and digital circuits except for the current output channels are powered by Vbat.

5 V Low Drop-Out linear regulator (VLDO)

NEX13120-Q100 has an integrated low-drop-out linear regulator to provide power supply to external CAN transceivers. The internal LDO powered by input voltage $V_{(Vbat)}$ provides a stable 5 V output with up to 80 mA constant current capability. Nexperia recommends a ceramic capacitor from 1 μ F to 10 μ F on the VLDO pin. The LDO has an internal current limit $I_{(VLDO_limit)}$ for protection and soft start. The capacitor charging time must be considered to total start-up time because the device is held in POR state if the capacitor voltage is not charged to above UVLO threshold.

Undervoltage Lockout (UVLO) and Power-On-Reset (POR)

NEX13120-Q100 uses UVLO and POR circuitry to clear its internal registers upon power up and to reset registers with its default values. NEX13120-Q100 has internal UVLO circuits so that when either input voltage $V_{(Vbat)}$ or LDO output voltage $V_{(VLDO)}$ is lower than its UVLO threshold, POR is triggered. In POR state, the device resets digital core and all registers to default value. FLAG_POR and FLAG_ERR register are set to 1 for each POR cycle to indicate the POR history. Before both powers are above UVLO thresholds, NEX13120-Q100 stays in POR state with all outputs off and \overline{FLT} pin pulled down. Once

both power supplies are above UVLO threshold, the device enters INIT mode for initialization releasing $\overline{\text{FLT}}$ pin pull-down. A programmable timer starts counting in INIT state, the timer length can be set by MTP register NV_INITTIMER. When the timer is completed, the device switches to NORMAL state. In INIT state, setting CLR_POR to 1 clears FLAG_POR, disables the timer, and sets the device to NORMAL state. Upon powering up, NEX13120-Q100 automatically loads all settings stored in MTP to correlated registers and sets the other registers to default value which do not have correlated MTP. All channels are powered up off-state by default to avoid unwanted blinking. Writing 1 to CLR_REG manually loads MTP setting to the correlated registers and set the other registers to default value. After CLR_REG is set, the FLAG_POR is cleared to 0.

Writing 1 to CLR_POR also resets the FLAG_POR register to 0. Nexperia recommends setting CLR_REG to 1 to clear the internal registers every time after POR. The CLR_REG automatically resets to 0.

Power supply (Vs)

NEX13120-Q100 has additional Vs input pins for powering all 12 high-side current output channels. The Vs voltage can be low to 3.8 V and up to 36 V for either automotive battery directly powered systems or an external DC to DC converter output. An external DC to DC converter can provide a regulated voltage for required LED output forward voltage from wide automotive battery voltage range.

NEX13120-Q100 has an internal undervoltage detection circuit for Vs input. When the Vs input voltage is lower than undervoltage threshold, $V_{(Vs_th_fall)}$, all 12 current output channels are disabled with $\overline{\text{FLT}}$ pin constantly pulled low and register flags set to 1 including FLAG_ERR bit and FLAG_VSUV bit. [Table 17](#) shows the detailed fault behavior in NORMAL state.

Programmable low Vs supply warning

NEX13120-Q100 uses its internal ADC to monitor supply voltage Vs. If the Vs is below allowable working threshold, the output voltage can be insufficient to keep the LED operating with the desired brightness output as expected. The Vs voltage is automatically compared with the threshold set by register CONF_ADCLOWVSTH. When the Vs voltage is below the threshold, the device sets the warning flag register FLAG_LOWVVS and FLAG_ERR to 1 in the status register. CLR_ERR can clear the FLAG_LOWVVS as well as other fault registers. Low-Vs warning will clear LED open and single-LED short faults. In addition, the LED open circuit and single LED short-circuit detection is disabled if the Vs voltage is below threshold to avoid the LED open circuit and to prevent the single LED short-circuit fault from being mis-triggered. The 4-bit register CONF_ADCLOWVSTH has 16 options covering from 4 V to 19 V as shown below.

Table 10. Low supply warning threshold setting

CONF_ADCLOWVSTH	0h	1h	2h	3h	4h	5h	6h	7h	8h	9h	Ah	Bh	Ch	Dh	Eh	Fh
Voltage (V)	5	6	7	8	9	10	11	12	13	14	15	16	17	18	19	4

14.3.2. Constant current output

Constant current output reference current with external resistor (R_{REF})

The NEX13120-Q100 must have an external resistor R_{REF} to set the internal current reference I_{REF} as shown in below [Fig. 33](#).

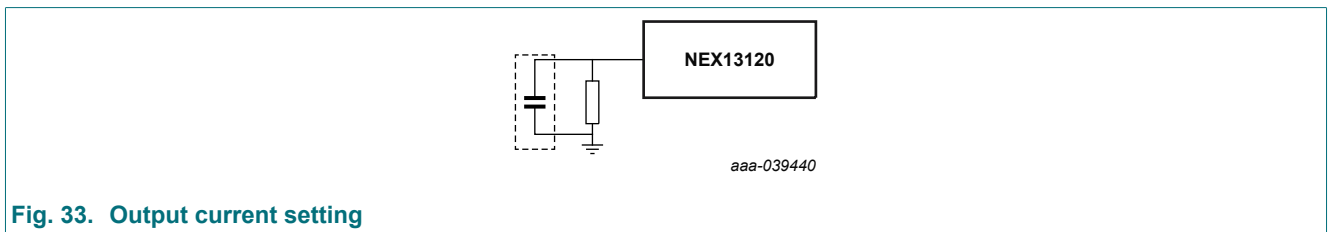

Fig. 33. Output current setting

The internal current reference, $I_{(FULL_RANGE)}$, is generated based on the I_{REF} multiplied by factor $K_{(REF)}$ to provide the full range current reference for each OUTx channel. The K_{REF} is programmable by 2-bit register CONF_REFRANGE with four different options. Use the following equation to calculate the $I_{(full_range)}$:

$$I_{\text{full_range}} = \frac{V_{\text{REF}}}{R_{\text{REF}}} \cdot K_{\text{REF}} \quad (1)$$

Where $V_{\text{REF}} = 1.235 \text{ V}$, $K_{\text{REF}} = 64, 128, 256$ or 512 (default)

Table 11. Reference current range setting

Reference	K_{REF}	Full range current (mA)			
		$R_{\text{REF}} = 6.34 \text{ k}\Omega$	$R_{\text{REF}} = 8.45 \text{ k}\Omega$	$R_{\text{REF}} = 12.7 \text{ k}\Omega$	$R_{\text{REF}} = 31.6 \text{ k}\Omega$
11b	512	100	75	50	20
10b	256	50	37.5	25	10
01b	128	25	18.75	12.5	5
00b	64	12.5	9.375	6.25	2.5

Nexperia recommends placing the R_{REF} resistor as close as possible to the REF pin with an up to 2.2 nF ceramic capacitor in parallel to improve the noise immunity. Nexperia recommends a 1 nF ceramic capacitor in parallel with R_{REF} .

64-step programmable high-side constant-current output

NEX13120-Q100 has 12-channels of high-side current sources. Each channel has its own enable configuration register CONF_ENCHn. Setting CONF_ENCHn to 1 enables the channel output, clearing the register to 0 disables the channel output. To completely turn off the channel current, user can clear channel enable bit CONF_ENCHn to 0. Upon power up, CONF_ENCHn is automatically reset to 0 to avoid unwanted blinking.

Each OUTn channel supports individual 64-step programmable current setting, also known as Dot Correction (DC). The DC feature can be used to set binning values for output LEDs or to calibrate the LEDs to achieve high brightness homogeneity based on external visual system to further save binning cost. The 6 bit register CONF_IOUTn sets the current independently, where n is the channel number from 0 to 11. The OUTn current can be calculated with Equation below:

$$I_{\text{(OUTn)}} = \frac{(\text{CONF_IOUTn} + 1)}{64} \times I_{\text{(full_range)}} \quad (2)$$

Where:

- CONF_IOUTn is programmable from 0 to 63
- n is from 0 to 11 for different output channel
- $I_{\text{(full_range)}}$ can be calculated with equation (1)

14.3.3. PWM dimming

NEX13120-Q100 integrates independent 12-bit PWM generators for each OUTn channel. The integrated PWM generator turns the current output for each OUTn channel on and off. The average current of each OUTn can be adjusted by PWM duty cycle independently, therefore, to control the brightness for LEDs in each channel.

PWM dimming frequency

The frequency for PWM dimming is programmable by 4-bit register CONF_PWMFREQ and register CONF_PWMSLOW with 32 options covering from 50 Hz to 23.4 kHz. CONF_PWMSLOW default value is 0, it will support 200 Hz to 23.4 kHz; when set CONF_PWMSLOW to 1, it supports lower PWM frequency, the range is 50 Hz to 5.86 kHz. Select the frequency for PWM dimming based on the minimum brightness requirement in application. NEX13120-Q100 supports down to 1 μ s minimum pulse current for all 12 channel outputs.

Below is the frequency table:

Table 12. PWM frequency setting

PWM frequency setting CONF_PWMFREQ	PWM cycle frequency	
	CONF_PWMSLOW = 0	CONF_PWMSLOW = 1
0	200	50
1	250	60
2	300	75
3	350	90
4	400	100
5	500	125
6	600	150
7	800	200
8	1000	250
9	1200	300
10	2000	500
11	4000	1000
12	5800	1500
13	7800	2000
14	9400	2300
15	23400	5800

ODPW Time

Because NEX13120-Q100 supports PWM control for adjusting LED brightness, the voltage on OUTn is like a pulse waveform. The output voltage and current ramp up to the target value in a certain period of time after the channel is turned on depending on the value of capacitor on the OUTn pin. The ramping up period is proportional to the capacitance value of the capacitor. To avoid the output voltage of each OUTn is measured in the ramping up transient period, NEX13120-Q100 integrates a $t_{(ODPW)}$ timer which is programmable by a 4-bit register CONF_ODPW to setup the ODPW time for all OUTn. The device does not start the OUTn diagnostics and ADC measurement until the $t_{(ODPW)}$ timer is overflow. The $t_{(ODPW)}$ timer is programmable from 20 μ s to 5 ms as described in Table 13. Nexperia recommends setting the $t_{(ODPW)}$ less than the PWM dimming period which is programmable by CONF_PWMFREQ register, otherwise the OUTn diagnostics and ADC measurement only operates properly when PWM duty cycle is set to 100 %.

Table 13. ODPW time setting

	ODPW time															
Binary code	0000	0001	0010	0011	0100	0101	0110	0111	1000	1001	1010	1011	1100	1101	1110	1111
$T_{(ODPW)}$ (μ s)	100	20	30	50	80	150	200	300	500	800	1000	1200	1500	2000	3000	5000

Phase shift PWM dimming

If all 12 output channels start PWM period at the same time, the peak output current of the chip is high. To reduce the peak current of the chip, the user can configure a phase shift. In phase shift PWM dimming mode, every three current output channels are formed as one group, one group phase is same and its phase is controlled by NV_PS0[1:0]. In case the phase shift is enabled, Group[x] turns on with a delay of $T\theta = X \times \theta \times 1/FPWM$, where $X = 0$ to 4. In case the phase shift is disabled, Group[x] turns on simultaneously with Group[x-1]. Both cases are shown in Fig. 34. When CONF_PSENx is set to 1, Group[x] phase shift is enabled, set CONF_PSENx to 0 can disable phase shift for Group[x]. θ is configurable by register CONF_PS0[1:0], θ is a ratio parameter of $1/FPWM$, FPWM is configured by CONF_PWMFREQ.

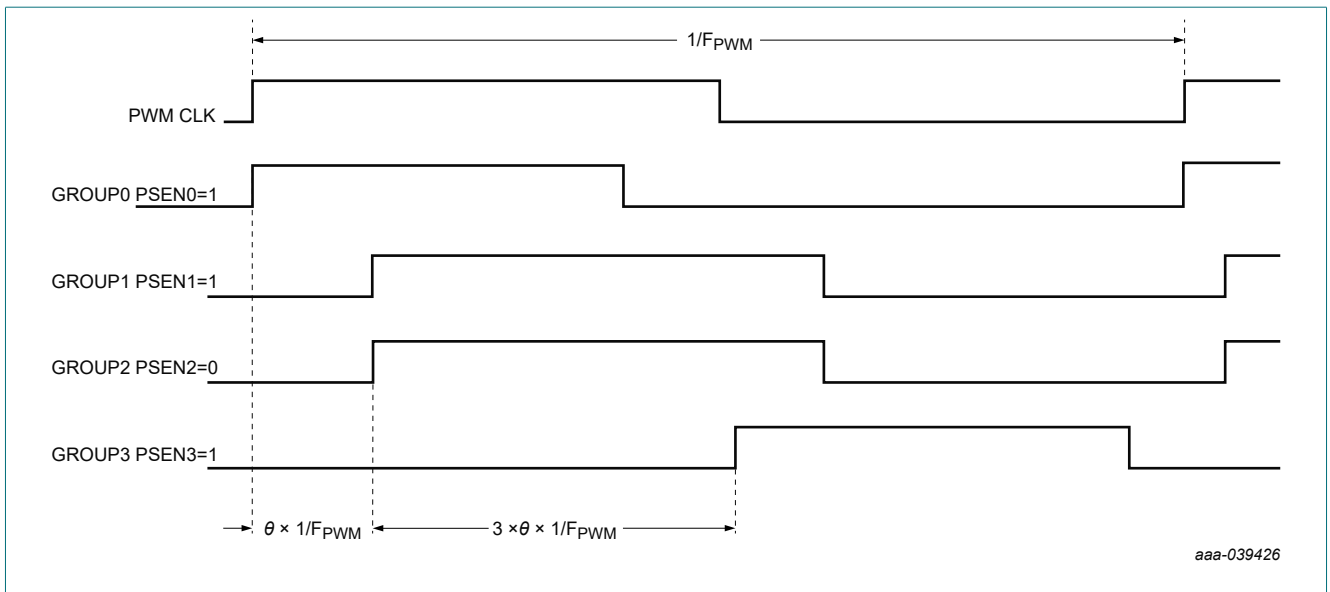

Group	Outputs	CONF_PS0	Description
GROUP0	OUT0, OUT1, OUT2	0	Delay time is 1/4 of $1/FPWM$
GROUP1	OUT3, OUT4, OUT5	1	Delay time is 1/6 of $1/FPWM$
GROUP2	OUT6, OUT7, OUT8	2	Delay time is 1/8 of $1/FPWM$
GROUP3	OUT9, OUT10, OUT11	3	Delay time is 1/12 of $1/FPWM$

Fig. 34. PWM phase shift

Linear brightness control

When register CONF_EXPEN is set to 0, the MSB 8 bits of 12-bit binary input to PWM generator are directly copied from 8 bit register CONF_PWMOUTn, and the LSB 4 bits are directly copied from 4-bit register CONF_PWMLOWOUTn. The PWM output duty cycle can be calculated with the following equation. The PWM output duty cycle is linearly controlled by the register CONF_PWMOUTn and CONF_PWMLOWOUTn, which provides linear brightness control to each channel output. When CONF_PWMOUTn is 00h, and CONF_PWMLOWOUTn is 0h, the channel will turn off.

$$D_{OUTn} = \frac{(16 \times \text{PWMOUTn} + \text{PWMLOWOUTn} + 1)}{4096} \times 100\% \quad (3)$$

Where:

PWMOUTn is decimal number from 0 to 255

PWMLOWOUTn is decimal number from 0 to 15

n is from 0 to 11

Because 12-bit PWM duty cycles require 2 bytes of write operation to update the completed data, the output PWM duty cycle is not changed in between of the two bytes data transmission. NEX13120-Q100 only updates the PWM duty cycle of any output when its high 8-bit CONF_PWMOUTn is written. When very fast brightness change is needed, such as fade-in and fade-out effects, it is essential to change the PWM duty cycles of all channels simultaneously. Setting CONF_SHAREPWM to 1 enables all channels using the PWM duty cycle setting of channels 0 to save communication latency.

Exponential brightness control

The NEX13120-Q100 can generate PWM duty-cycle outputs that follow an exponential curve. When the CONF_EXPEN register is set to 1, the integrated conversion circuit provides a one-to-one conversion from the 8-bit register CONF_PWMOUTn to a 12-bit binary code that follows an exponential increment, as illustrated in Fig. 35. In exponential mode, the upper 8 bits (MSB) of the PWM configuration register serve as the input to the exponential conversion circuit. The output from this circuit is a 12-bit value, which is used as the duty cycle of the PWM engine.

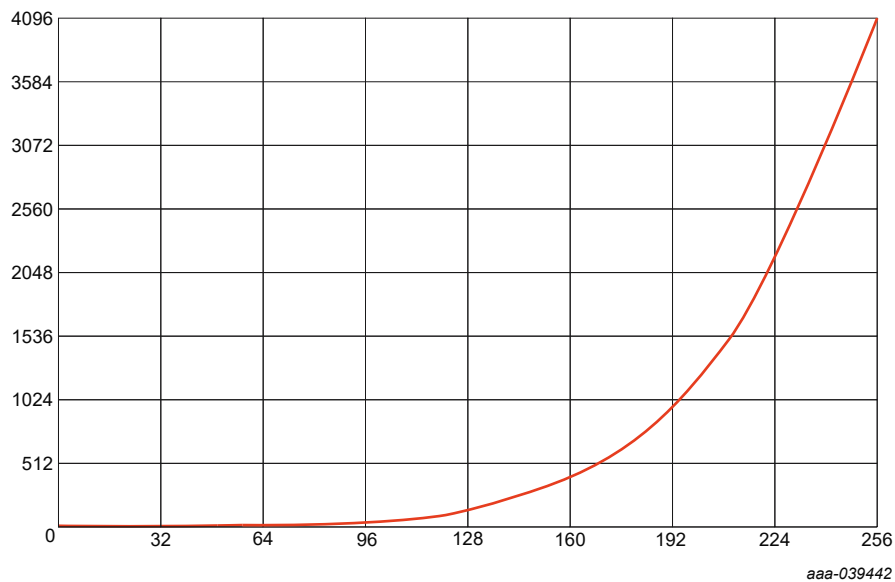

Fig. 35. PWM duty cycle versus 8 bit code for exponential dimming

CONF_EXPEN bit selects the dimming method between linear or exponential. Setting the bit CONF_EXPEN to 1 enables the conversion circuit for exponential dimming curve. In exponential PWM dimming mode, 8 bit register CONF_PWMOUTn is converted to 12 bit PWM duty cycle by conversion circuit automatically. Clearing the bit CONF_EXPEN to 0 disables the conversion. In this case, users must provide 12 bit PWM duty cycle. CONF_PWMOUTn stores the high 8-bit of 12-bit PWM duty-cycle information. CONF_PWMLOWOUTn stores the low 4 bit.

To avoid visible brightness flicker for exponential dimming, choose PWM frequency higher than 2 kHz through setting register CONF_PWMFREQ. Higher PWM frequency can also avoid the visible LED flash in video display due to the low beat frequency between digital camera shutter frequency and PWM frequency for LED dimming.

During power-up or in Fail-Safe state, the registers CONF_EXPEN, CONF_PWMOUT_n, CONF_PWMFREQ are automatically reset to their default values stored in MTP register NV_EXPEN, NV_PWMOUT_n, NV_PWMFREQ. CONF_PWMLOWOUT_n is reset to Fh as default value.

In Fail-Safe state, PWM generator only uses 8-bit MTP data from NV_PWMOUT_n to build PWM duty cycle output and ignores the low 4 bit. The PWM duty-cycle calculation is as shown in equation below. When NV_PWMOUT_n is 00h, the channel will turn off.

$$D_{OUTn} = \frac{NV_PWMOUTn+1}{256} \times 100\% \quad (4)$$

where:

NV_PWMOUT_n is decimal number from 0 to 255

n is from 0 to 11 for different output channel

14.3.4. Fail-Safe state operation

The NEX13120-Q100 supports independent channel brightness control through the UART interface. The brightness of each channel is adjustable according to its DC current register I_{OUTn}, PWM duty cycle register CONF_PWMOUT_n, CONF_PWMLOWOUT_n and channel enable register CONF_ENOUT_n setting. The brightness of each channel reflects its register setting value immediately after register is successfully updated through the UART interface by master unit.

However, the master unit will lose control for all current channels if the UART communication fails between master unit and the NEX13120-Q100. For example, the interface cable broke by accident. Therefore, the brightness for all output channels of the NEX13120-Q100 is stuck and the ON and OFF control for all output channels are missing too. To keep the basic ON and OFF control for each output channel, the NEX13120-Q100 provides a FAIL-SAFE state when the communication to master is lost. For detailed description for FAIL-SAFE state entering and quitting criteria, refer to Device Functional Modes. When the NEX13120-Q100 is entering FAIL-SAFE state, all the registers are set to default value or reloaded from MTP, including CONF_IOUT_n, CONF_PWMOUT_n and CONF_ENOUT_n. The pre-programmed settings in the MTP are loaded and the corresponding registers are reset to the default values. During the MTP loading process, all the PWM output channels are disabled, and the channels' faults detected in the NORMAL state are cleared. The NEX13120-Q100 provides one hardware input pin, FM to turn on or off corresponding current output channels in FAIL-SAFE state. Each current output channel has its own register. The FAIL-SAFE state also allows the NEX13120-Q100 to operate as a standalone device without master controlling in the system. The FLT pin is used as a fault indicator to achieve one-fails-all-fail or one-fails-others-on diagnostics requirement. When low quiescent current in fault mode is required, the device must be set as one-fails-all-fail. In this case, if a fault is triggered, the device goes into low current fault mode.

14.3.5. 8 bit ADC

NEX13120-Q100 has integrated a successive-approximation-register (SAR) ADC for diagnostics. It routinely monitors supply voltage if the ADC is idle and stores V_s conversion results into ADC_Vs. To manually read the voltage of an ADC channel as listed in below Table , user must write the 5 bit register CONF_ADCCH to select channel. Once CONF_ADCCH register is written, the onetime ADC conversion starts and clears FLAG_ADCDONE register. If the ADC conversion is completed, the ADC result is available in 8 bit register ADC_OUT and sets FLAG_ADCDONE to 1. Reading the ADC_OUT register also clears FLAG_ADCDONE, and the FLAG_ADCDONE is set to 0 after reading completion. Because NEX13120-Q100 supports PWM control for adjusting LED brightness, the voltage on OUT0 to OUT11 is like a pulse waveform. When the current output is enabled by setting CONF_ENCH_n to 1, the ADC measures the voltage on assigned OUT_n after the channel is turned on with t_(diag_pulse) delay time, which is programmable by 4 bit register CONF_ODPW. When the channel is disabled by setting CONF_ENCH_n to 0, the ADC samples the voltage on assigned OUT_n at off state. The analog value can be calculated based on the read back binary code with Equation 5 and Table 14. Auto scan for below values

$$\text{AnalogValue} = a + k \times (\text{ADC_OUT}) \quad (5)$$

Were ADC_OUT is decimal number from 0 to 255

The NEX13120-Q100 also provides ADC auto-scan mode for single-led short-circuit diagnostics. The detail description for auto-scan mode can be found in On-Demand Off-State Single-LED Short-Circuit (SS) Diagnostics.

In ADC auto-scan mode, If MAXOUT channel is selected by writing 05h to CONF_ADCCH, the maximum voltage of OUT0 to OUT11 is recorded into ADC_OUT register. The maximum channel output voltage is available after at least one output

PWM cycle is completed. Based on the measured maximum output voltage and supply voltage, microcontroller is able to regulate supply voltage from previous power stage to minimize the power consumption on the NEX13120-Q100. To refresh the MAXOUT result, Nexperia recommend setting CONF_ADCCH to a different value before setting CONF_ADCCH to 05 each time; MAXOUT value would not refresh, if CONF_ADCCH remains at 05h. Basically, microcontroller needs to program the output voltage of previous power stage to be just higher than the measured maximum channel output voltage plus the required dropout voltage $V_{(OUT_drop)}$ of the NEX13120-Q100. In this way, the NEX13120-Q100 can achieve minimum power consumption, and overall power efficiency is optimized.

Table 14. ADC channel definition

CHANNEL	CONF_ADCCH	NAME	ADC CALCULATION PARAMETER (a)	ADC CALCULATION PARAMETER (k)	Comment
0	00h	REF	0.007 V	0.0101 V/LSB	Reference voltage
1	01h	VS	0.0673 V	0.0804 V/LSB	Supply voltage
2	02h	VLDO	0.0465V	0.022 V/LSB	5 V VLDO output voltage
3	03h	TEMPSNS	-242.35 °C	2.152 °C/LSB	Internal temperature sensor
4	04h	IREF	0.9969 µA	0.9969 µA/LSB	Reference current
5	05h	MAXOUT	0.0673 V	0.0804 V/LSB	Maximum channel output voltage
6	06h	VBAT	0.1346 V	0.1608 V/LSB	Vbat pin voltage
8-15	08h- 0Fh	Reserved	Reserved	Reserved	Reserved
16	10h	OUT0	0.0673 V	0.0804 V/LSB	Output voltage channel 0
17	11h	OUT1			Output voltage channel 1
18	12h	OUT2			Output voltage channel 2
19	13h	OUT3			Output voltage channel 3
20	14h	OUT4			Output voltage channel 4
21	15h	OUT5			Output voltage channel 5
22	16h	OUT6			Output voltage channel 6
23	17h	OUT7			Output voltage channel 7
24	18h	OUT8			Output voltage channel 8
25	19h	OUT9			Output voltage channel 9
26	1Ah	OUT10			Output voltage channel 10
27	1Bh	OUT11			Output voltage channel 11
28	1Ch	Reserved	Reserved	Reserved	Reserved
29	1Dh	Reserved	Reserved	Reserved	Reserved
30	1Eh	Reserved	Reserved	Reserved	Reserved
31	1Fh	Reserved	Reserved	Reserved	Reserved

14.3.6. Diagnostic and protection in NORMAL state

The NEX13120-Q100 has full-diagnostics coverage for supply voltage, current output, and junction temperature. In NORMAL state, the device detects all failures and reports the status out through the FLT pin or FLAG registers, without any actions taken by the device except VBAT UVLO, Vs undervoltage and overtemperature protection. The master controller must handle all fault actions, for example, retry several times and shut down the outputs if the error still exists. The fault behavior in NORMAL state can be found in [Table 17](#).

VBAT and VLDO undervoltage lockout diagnostics in NORMAL state

When VBAT or VLDO voltage drops below its UVLO threshold, the device enters POR state. Upon voltage recovery, the device automatically switches to INIT state with FLAG_POR and FLAG_ERR set to 1. The master controller can write 1 to register CLR_POR to clear the FLAG_POR, write 1 to CLR_ERR to clear FLAG_ERR, and the CLR_POR, CLR_ERR bit automatically returns to 0.

Low Vs-supply warning diagnostics in NORMAL state

The NEX13120-Q100 continuously monitors the Vs voltage and compares the results with internal threshold $V_{(LOWVSTH)}$ set by CONF_ADCLOWVSTH for low-Vs voltage warning. If the Vs voltage is lower than threshold, the device pulls \overline{FLT} pin down with one pulsed current sink for 50 μ s to report the fault and set flag registers including FLAG_LOWVS and FLAG_ERR to 1. The fault is latched in flag registers. When the Vs voltage rises above low-Vs warning threshold, the master controller must write 1 to register CLR_ERR to clear FLAG_LOWVS and FLAG_ERR. The CLR_ERR bit automatically returns to 0. The low-Vs warning is also used to disable the LED open-circuit detection and single-LED short-circuit detection. When the voltage applied on Vs pin is higher than the threshold $V_{(LOWVSTH)}$, the NEX13120-Q100 enables LED open-circuit and single-LED short-circuit diagnosis. When Vs is lower than the threshold $V_{(LOWVSTH)}$, the device disables LED-open-circuit detection and single-LED short-circuit diagnosis. Because when Vs drops below the maximum total LED forward voltage plus required $V_{(OUT_drop)}$ at required current, the NEX13120-Q100 is not able to deliver sufficient current output. The device pulls the voltage of each output channel as close as possible to the Vs. In this condition, the LED open-circuit fault or single-LED short-circuit fault can be detected and reported by mistake. Setting the low-Vs warning threshold high enough can avoid the LED open-circuit and single LED short-circuit fault being detected when Vs drops to low. The $V_{(LOWVSTH)}$ is programmable from 4 V to 19 V.

Vs-supply undervoltage diagnostics in NORMAL state

The NEX13120-Q100 provides an internal analog comparator to monitor the Vs voltage for undervoltage protection. If the Vs voltage falls below the internal threshold, $V_{(Vs_th_fall)}$, the device pulls the \overline{FLT} pin low with constant current sink to report the fault and set flag registers including FLAG_VSU and FLAG_ERR to 1. The supply undervoltage detection is used to disable all current output. When the voltage applied on the Vs pin is higher than the threshold $V_{(Vs_th_rise)}$, the NEX13120-Q100 enables all current outputs. When Vs is lower than the threshold $V_{(Vs_th_fall)}$, the device disables every output to avoid the unwanted LED flickering or output fault triggered improperly.

The fault is latched in flag registers. When the supply voltage rises above $V_{(Vs_th_rise)}$, the master controller must write register CLR_ERR to 1 to clear FLAG_VSU and FLAG_ERR. The CLR_ERR bit automatically returns to 0.

Reference diagnostics in NORMAL state

NEX13120-Q100 integrates diagnostics for REF resistor open and short fault in NORMAL state. The device monitors the reference current $I_{(REF)}$ set by external resistor $R_{(REF)}$. Use Equation 6 to calculate the $I_{(REF)}$. If the current output from REF pin $I_{(REF)}$ is lower than $I_{(REF_OPEN_th)}$, the reference resistor open-circuit fault is reported. The reference resistor short-circuit fault is reported if the voltage of REF pin $V_{(REF)}$ is lower than $V_{(REF_SHORT_th)}$. The device pulls the \overline{FLT} pin down with constant current sink and sets flag registers including FLAG_REF and FLAG_ERR to 1. The fault is latched in flag registers.

After the REF pin $I_{(REF)}$ and $V_{(REF_SHORT_th)}$ recover to normal, the device releases \overline{FLT} pin pull-down automatically and the master controller must send CLR_ERR to clear FLAG_REF and FLAG_ERR. CLR_ERR automatically returns to 0.

In normal state, the device does not perform any actions automatically when reference resistor fault is detected. However, the output may not work properly, and the output current may be operating at high current level when REF short. Nexperia recommended for master controller to shut down the device outputs and report error to upper level control system such as body control module (BCM).

The reference current $I_{(REF)}$ is set by external resistor $R_{(REF)}$. The $I_{(REF)}$ can be calculated with Equation 6. $V_{(REF)}$ typically is 1.235V.

$$I_{(REF)} = \frac{V_{(REF)}}{R_{(REF)}} \quad (6)$$

Pre-thermal warning in NORMAL state

The NEX13120-Q100 has pre-thermal warning at typical 135°C. When the junction temperature, T_j , of NEX13120-Q100 rises above pre-thermal warning threshold, the device reports pre-thermal warning, pull \overline{FLT} pin with pulsed current sink for 50 μ s and sets the flag registers including FLAG_PRETSD and FLAG_ERR to 1. The fault is latched in flag registers. When the junction temperature of NEX13120-Q100 falls below pre-thermal warning threshold, the master controller must write 1 to CLR_ERR register to clear FLAG_PRETSD and FLAG_ERR. The CLR_ERR bit automatically returns to 0. When more accurate thermal measurement on LED unit is required, one current output channel can be sacrificed to provide current bias to external thermal resistor such as PTC or NTC. The voltage of external thermal resistor can be measured by integrated

ADC to acquire the temperature information of the thermal resistor located area. The master controller can determine actions based on the acquired temperature information to turn off or reduce current output.

Overtemperature protection in NORMAL state

The NEX13120-Q100 has overtemperature protection at $T_{(TSD1)}$, typical 175 °C. When device junction temperature T_j further rises above overtemperature protection threshold, the device turns off all output drivers, pulls the \overline{FLT} pin low with constant current sink to report fault, and sets the flag registers including FLAG_TSD and FLAG_ERR to 1. The fault is latched in flag registers. When the junction temperature falls below $T_{(TSD1)} - T_{(TSD1_HYS)}$, the device resumes all outputs and releases \overline{FLT} pin pull-down. The master controller must write 1 to CLR_ERR to clear FLAG_TSD and FLAG_ERR. The CLR_ERR bit automatically returns to 0.

Overtemperature shutdown in NORMAL state

When the T_j rises too high above $T_{(TSD2)}$, 180 °C typically, the NEX13120-Q100 turns off the internal linear regulator, VLDO output to shut down all the analog and digital circuit. The \overline{FLT} pin is pulled down by constant current sink to report the fault, and the FLAG_POR and FLAG_ERR are all set to 1. When the T_j drops below $T_{(TSD2)} - T_{(TSD2_HYS)}$, the NEX13120-Q100 restarts from POR state with all the registers cleared to default value and \overline{FLT} pin released. The master controller must write 1 to CLR_POR to clear both FLAG_POR and FLAG_ERR after fault removal. The CLR_POR bit automatically returns to 0.

Communication loss diagnostic in NORMAL State

The NEX13120-Q100 monitors the UART interface for communication with an internal watchdog timer. Any successful non-broadcast communication with correct CRC and address matching target device automatically resets the timer. If the watchdog timer overflows, the device automatically switches to Fail-Safe state as indicated by external FM input. If FM = 0, the device switches to Fail-Safe state 0, If FM = 1, the device switches to Fail-Safe state 1. The watchdog timer is programmable by 4 bit register CONF_WDTIMER. The NEX13120-Q100 can directly enter Fail-Safe states from normal mode by burning NV_WDTIMER to 0xFh. Disabling the watchdog timer by setting CONF_WDTIMER to 0x0h prevents the device from getting into Fail-Safe state.

LED open-circuit diagnostics in NORMAL State

The NEX13120-Q100 integrates LED open-circuit diagnostics to allow users to monitor LED status in real time. The device monitors voltage difference between V_s and O_{UTn} to judge if there is any open-circuit failure. The V_s voltage is also monitored in parallel with programmable threshold to determine if V_s is high enough for open-circuit diagnostics.

The open-circuit monitor is only effective during PWM-ON state with programmable minimal pulse width greater than $t_{(ODPW)}$. The $t_{(ODPW)}$ is programmed by register ODPW. If PWM on-time is less than $t_{(ODPW)}$, the device does not report any open-circuit fault. When the device supply voltage V_s is below the threshold $V_{(LOWVSTH)}$ set by register CONF_ADCLLOWVSTH, the LED open-circuit is not detected nor reported. When the voltage difference $V_s - V_{(OUTn)}$ is below threshold $V_{(OPEN_th_rise)}$ with duration longer than $t_{(ODPW)}$, and the device supply voltage V_s is above the threshold $V_{(LOWVSTH)}$ set by register CONF_LOWVSTH, the NEX13120-Q100 pulls the FLT pin down with one pulsed current sink for 50 μ s to report fault and set flag registers including FLAG_OPENCHn, FLAG_OUT and FLAG_ERR to 1. In NORMAL state, the device does not take any actions in response to the LED open-circuit fault and waits for the master controller to determine the protection behavior. The fault is latched in flag registers. When the voltage difference $V_s - V_{(OUTn)}$ rises above threshold $V_{(OPEN_th_rise)}$ with duration longer than $t_{(ODPW)}$, or the device supply voltage V_s is below the threshold $V_{(LOWVSTH)}$, the master controller must write 1 to CLR_ERR to clear FLAG_OPENCHn, FLAG_OUT and FLAG_ERR. The CLR_ERR bit automatically returns to 0.

LED short-circuit diagnostics in NORMAL state

The NEX13120-Q100 has internal analog comparators to monitor all channel outputs with respect to a fixed threshold for reporting O_{UTn} short to GND fault. The short-circuit detection is only effective during PWM-ON state with programmable minimal pulse width of $t_{(ODPW)}$. The $t_{(ODPW)}$ is programmable by register ODPW. If PWM on-time is less than $t_{(ODPW)}$ the device can not report any short-circuit fault. When the voltage $V_{(OUTn)}$ is below threshold $V_{(SG_th_fall)}$ with duration longer than deglitch timer length of $t_{(ODPW)}$, the device pulls the FLT pin down with pulsed current sink for 50 μ s to report fault and set flag registers including FLAG_SHORTCHn, FLAG_OUT and FLAG_ERR. In NORMAL state, the device does not take any actions in response to the LED short-circuit fault and waits for the master controller to determine the protection behavior.

The fault is latched in flag registers. When the voltage $V_{(OUTn)}$ rises above threshold $V_{(SG_th_rise)}$ with duration longer than deglitch timer length of $t_{(ODPW)}$, the master controller must write 1 to CLR_ERR to clear FLAG_SHORTCHn, FLAG_OUT and FLAG_ERR. The CLR_ERR bit automatically returns to 0.

On-demand OFF-state invisible diagnostics

It is commonly required to ensure there is no fault on each LED load before lighting them up, especially for LED animation. Otherwise, the LED fault is detected in the middle of the admiration pattern, which results a random and uncertain failure animation pattern. NEX13120-Q100 provides a solution to diagnose the LED open-circuit or LED short-circuit fault without lighting up the LEDs. With this feature, the master controller can initiate the on-demand invisible diagnostics before commencing the animation sequence. If one of the channels fails, the device is able to detect it immediately instead of only when the fault channel is turned on in traditional diagnostics mode. To initiate the on-demand invisible diagnostics, the master controller writes register CONF_INVDIAGSTART to 1. The register CONF_INVDIAGSTART returns to 0 automatically in the next clock cycle. Once the diagnostics started, the on-demand diagnostics ready flag FLAG_ODREADY is cleared to 0. Once the diagnostics finished, the FLAG_ODREADY is set to 1. If any channel has output failures, its on-demand diagnostic flag FLAG_ODDIAGCHn is set to 1. To ensure the invisibility of the diagnostics, the NEX13120-Q100 outputs only a small DC current in short period to each output channel and detects if there is any LED open-circuit or LED short-circuit failures. The output DC current $I_{(ODIOUT)}$ can be adjusted to a proper value by setting the DC current CONF_ODIOUT and ignoring the DC current setup by register CONF_IOUTn. The pulse-width $t_{(ODPW)}$ of output DC current can be programmable by CONF_ODPW and neglecting duty cycle configuration by register CONF_PWMOUTn. At the end of the current output pulse, if there is any LED open-circuit fault, the NEX13120-Q100 pulls the FLT pin down with one pulsed current sink for 50 μ s to report fault and set flag registers including FLAG_OPENCHn, FLAG_OUT and FLAG_ERR to 1. If there is any LED short-circuit fault, the NEX13120-Q100 pulls the FLT pin down with one pulsed current sink for 50 μ s to report fault and set flag registers including FLAG_SHORTCHn, FLAG_OUT and FLAG_ERR to 1. The master controller must write 1 to CLR_ERR register to clear fault flags after the fault removal is verified by another on-demand off-state invisible diagnostics. Nexperia recommends turning off all output channels by setting CONF_ENCHn to 0 before invisible diagnostics. For invisible diagnostics mode, it is required to have a short-pulse and low output current to avoid lighting up LEDs. However, the diagnostics are strongly affected by large loading capacitance. If the invisible diagnostics pulse fails to charge output capacitance above short-circuit threshold, the device reports a false short-circuit failure. If pulse failed to charge output above open-circuit threshold at maximum supply voltage, the device does not report open-circuit fault correctly. Thus, the DC current and period of the detection pulse must be carefully selected based on the capacitance value at output in real applications.

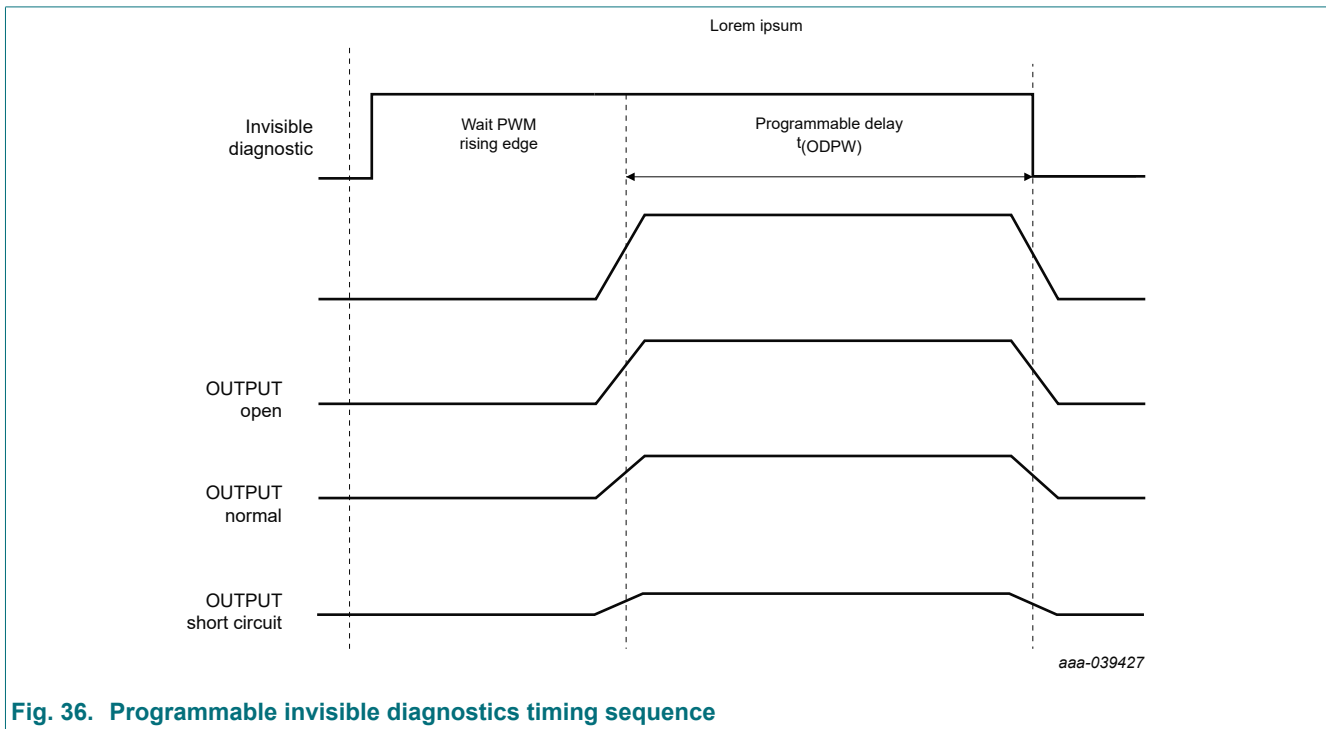

Fig. 36. Programmable invisible diagnostics timing sequence

On-demand OFF-state single-LED short-circuit (SS) diagnostics

To provide single-LED short-circuit diagnostics, the NEX13120-Q100 uses internal ADC to compare the output channel voltage with respect to pre-set threshold $V_{(ADC\SHORTTH)}$. Setting the register CONF_SSSTART to 1 starts the diagnostics immediately. The CONF_SSSTART returns to 0 in the next clock cycle. Once the diagnostics starts, the on-demand diagnostics ready flag FLAG_ODREADY are cleared to 0. Once the diagnostics finished, the FLAG_ODREADY are set to 1 in off-state single-LED short-circuit diagnostics, once the master controller initiates single-LED short-circuit diagnostics by setting the register CONF_SSSTART, the device sequentially turns on all outputs starting from OUT0 with DC current $I_{(ODIOUT)}$ programed by register CONF_ODIOUT and pulse width $t_{(ODPW)}$ programmable by CONF_ODPW. At the end of pulse, the device initiates an AD conversion. As long as the completion of ADC conversion, the result is compared with pre-set threshold $V_{(ADC\SHORTTHn)}$ and start the diagnostics for the next channel. After all channels have been checked, the NEX13120-Q100 also checks if the supply voltage is over $V_{(ADCLOWVSTH)}$ to make sure the device is not in low-dropout conditions. If the supply voltage is truly lower than $V_{(ADCLOWVSTH)}$, the single-LED short-circuit fault cannot be detected and reported. If the supply voltage is high enough, and any one channel output voltage is less than pre-set threshold $V_{(ADC\SHORTTHn)}$, the NEX13120-Q100 pulls the FLT pin down with pulsed current sink for 50 μ s to report fault and set the flag register including FLAG_ODDIAGCHn, FLAG_OUT and FLAG_ERR to 1. The master controller must write 1 to CLR_ERR register to clear the fault flags after fault removal is verified by another on-demand off-state single-LED short-circuit diagnostic. The configurable DC current $I_{(ODIOUT)}$ and pulse width $T_{(ODPW)}$ can be used to minimize the optical impact during on-demand diagnostics. Nexperia recommends using the normal current setting and short pulse-width to avoid visible pulse; however, the parasitic capacitance impact at each output must take care of to leave enough charging time and avoid false alarm. Low DC current setting also reduces LED forward voltage, which also affects the integrity of the detection. Thus, the threshold set by CONF_ADCSHORTTHn must be selected carefully. Setting CONF_ODIOUT to 0xFh uses the channel current setting by registering CONF_IOUTn as on-demand pulse current. The NEX13120-Q100 provides two alternative threshold $V_{(ADC\SHORTTH0)}$ and $V_{(ADC\SHORTTH1)}$ for single-LED short-circuit detection selected by ADCSHORTTHCHn independently for each current output. The $V_{(ADC\SHORTTH0)}$ is selected for current OUTn when ADCSHORTTHCHn is set to 0, however $V_{(ADC\SHORTTH1)}$ is selected when ADCSHORTTHCHn is set to 1. The actual voltage value for $V_{(ADC\SHORTTH0)}$ and $V_{(ADC\SHORTTH1)}$ is programmable by two 8 bit registers CONF_ADCSHORTTH0 and CONF_ADCSHORTTH1 from 0V to 20.56 V at 80 mV interval. The $V_{(ADC\SHORTTHn)}$ can be calculated with below equation:

$$V_{(ADC\SHORTTHn)} = a + K \times (CONF_ADC\SHORTTHn) \quad (7)$$

Where:

$$a = 0.0673 \text{ V}$$

$$K = 0.0804 \text{ V/LSB}$$

CONF_ADCSHORTTHn is decimal number from 0 to 255

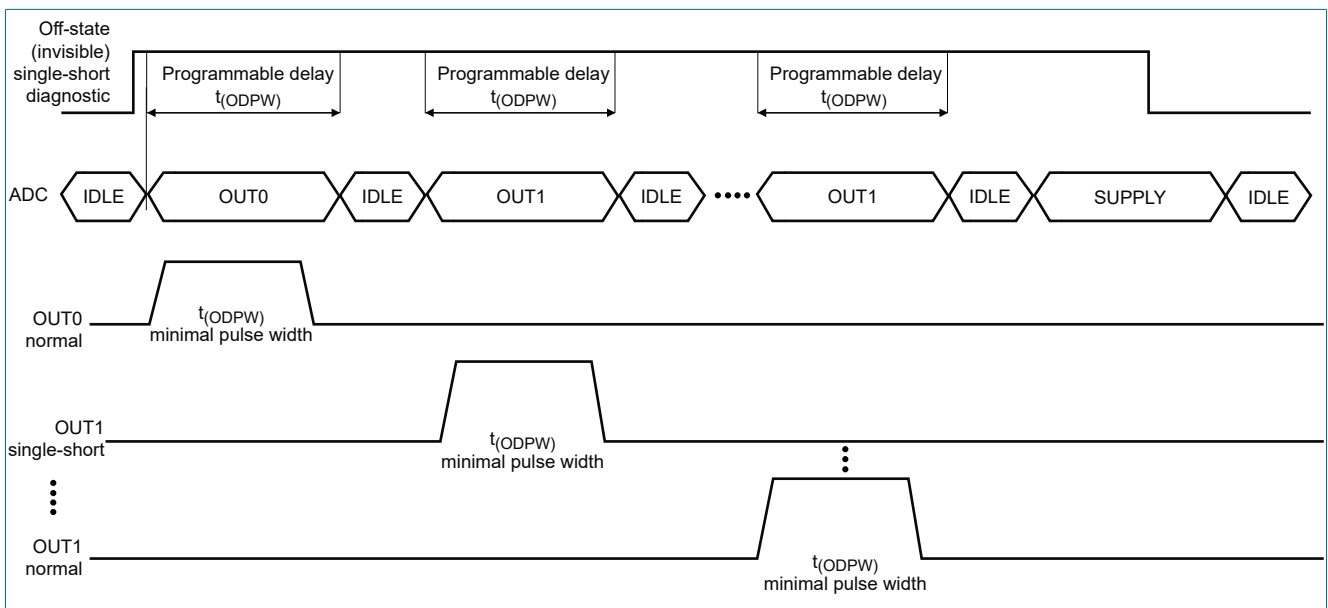

Fig. 37. Single-LED short-circuit OFF-state timing sequence

Single-LED short-circuit detection in NORMAL state (auto scan)

In order to check LED single-LED short-circuit issue during lighting up, the NEX13120-Q100 also provides automatically single- LED short-circuit (AUTOSS) diagnostic. Setting the register CONF_AUTOSS to 1 enables the scanning of each current out channel at the beginning of every PWM cycle. The AutoSS detection takes 4 PWM cycles to complete scanning 12 output channels. One group takes one PWM cycle. After sampling 12 output channel voltages, ADC will auto scan other values, includes VREF, VLDO, TEMPSNS, IREF, VBAT, VBG1. Fig. 38 shows the details. For function safety considerations, if CONF_AUTOSS is set to 1, NEX13120-Q100 will compare all ADC out value with related threshold. Find the threshold in page 19. On PWM rise edge, the device waits for a programmable delay $T_{(ODPW)}$ programmable by CONF_ODPW to allow output voltage settle and start AD conversion. The minimal pulse width of PWM must be longer than programmable delay $T_{(ODPW)}$ plus 3 times AD conversion time $T_{(CONV)}$ to make sure 3 output channels can be scanned in one PWM cycle. The NEX13120-Q100 checks low-Vs warning to avoid reporting the single-LED short-circuit fault by mistake in low-dropout mode. If the supply voltage is truly lower than $V_{(ADCLOWVSTH)}$, the single-LED short-circuit fault cannot be detected and reported. If the supply voltage is high enough, and any one channel output voltage is less than pre-set threshold $V_{(ADCSHORTTH)}$, the NEX13120-Q100 pulls FLT pin down with pulsed current sink for 50 μ s to report fault and set the flag register including FLAG_ODDIAGCHn, FLAG_OUT and FLAG_ERR to 1. The master controller must write 1 to CLR_ERR register to clear the fault flags. The NEX13120-Q100 provides two alternative threshold $V_{(ADCSHORTTH0)}$ and $V_{(ADCSHORTTH1)}$ for single-LED short-circuit detection selected by ADCSHORTTHCHn independently for each current output. The $V_{(ADCSHORTTH0)}$ is selected for current OUTn when ADCSHORTTHCHn is set to 0, however $V_{(ADCSHORTTH1)}$ is selected when ADCSHORTTHCHn is set to 1. The actual voltage value for $V_{(ADCSHORTTH0)}$ and $V_{(ADCSHORTTH1)}$ is programmable by two 8 bit registers CONF_ADCSHORTTH0 and CONF_ADCSHORTTH1 from 0V to 20.56 V at 80 mV interval. If any channel is disabled by CONF_ENCHn to 0, the AutoSS diagnostics skips the channel. During the single-led short-circuit diagnostics, the ADC keeps the on-demand ADC conversion request pending until single-led short-circuit diagnostics finished. When CONF_AUTOSS is set to 1, selecting MAXOUT by writing 05h to CONF_ADCCH automatically outputs the ADC conversion result to register ADC_OUT for the output channel with the highest voltage in all scanned channels. The master controller can adjust the previous power stage output voltage based on the voltage difference read back from register ADC_Vs and ADC_OUT to minimize the voltage drop on the NEX13120-Q100 as well as temperature rising if the output voltage of previous power stage is programmable by digital interface.

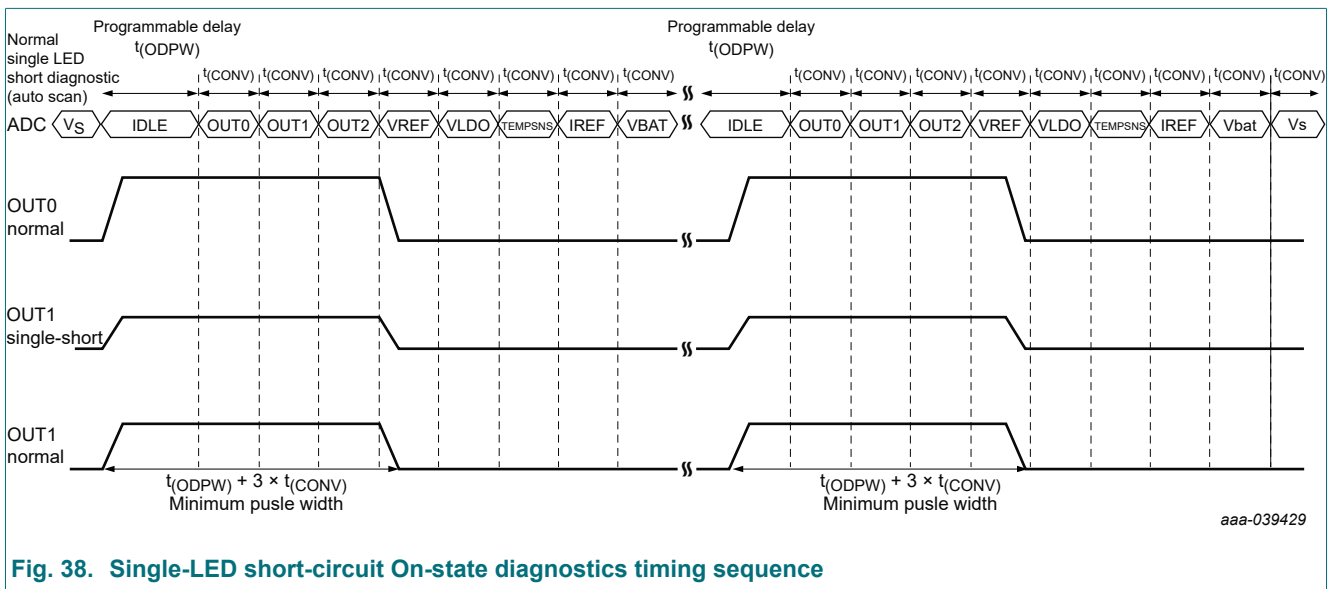

Fig. 38. Single-LED short-circuit On-state diagnostics timing sequence

MTP CRC error in NORMAL state

The NEX13120-Q100 implements MTP CRC check after loading the MTP code to configuration register in NORMAL state. The calculated CRC result is sent to register CALC_MTPCRC and compared to the data in register MTPCRC, which stores the CRC code for all MTP registers. If the code in register CALC_MTPCRC is not matched to the code in register MTPCRC, the NEX13120-Q100 pulls the \overline{FLT} pin down with pulsed current sink for 50 μ s to report the fault and set the registers including FLAG_MTPCRC and FLAG_ERR to 1. The NEX13120-Q100 only loads MTP to corresponding registers one time during initialization state. Reloading the MTP triggers the MTP CRC check. The master controller must write CLR_ERR to 1 to clear the fault flags, and the CLR_ERR bit automatically returns to 0. The CRC code algorithm for multiple bytes of binary

data is based on the polynomial, $X^8 + X^5 + X^4 + 1$. The CRC code contain 8 bits binary code, and the initial value is FFh. All bits code shift to MSB direction for 1 bit with three exclusive-OR calculation. A new CRC code for one byte input could be generated after repeating the 1-bit shift and three exclusive-OR calculation for 8 times. Based on this logic, the CRC code can be calculated for all the EEPROM register byte. MTPCRC calculation range as below:

Table 15. CRC calculation definition

	CRC calculation range
CALC_NVCR	80h to 8Bh, A0h to ABh, C0h to CEh

Communication loss diagnostic in NORMAL state

The NEX13120-Q100 monitors the UART interface for communication with an internal watchdog timer. Any successful non-broadcast communication with correct CRC and address matching target device automatically resets the timer. If the watchdog timer overflows, device automatically switches to FAIL-SAFE state and sets the FLAG_FS to 1. The master controller can access the NEX13120-Q100 and write 1 to CLR_FS to set the device to NORMAL state again when the communication recovers. The watchdog timer is programmable by 4-bit register CONF_WDTIMER. The NEX13120-Q100 can directly enter FAIL-SAFE state from NORMAL state by burning MTP of NV_WDTIMER to Fh. Disabling the watchdog timer by setting CONF_WDTIMER to 0h prevents the device from getting into FAIL-SAFE state.

ECC protection

For protecting possible single-bit memory content error. Each byte to be stored in the MTP is encoded with 6-bit ECC parity bits. These 6 bits together with the original 8 data bits occupy two bytes in the MTP memory at 2 consecutive addresses. The ECC decoder can correct any single-bit error in the 14 bits (data and parity) read value. The corrected data is then sent to the MTP. When memory content error occurred, NEX13120-Q100 pulls the $\overline{\text{FLT}}$ pin down with pulsed current sink for 50 μs to report the fault and set the registers including FLAG_ECC and FLAG_ERR to 1. Writing 1 to CLR_ERR can clear FLAG_ECC and FLAG_ERR. Reloading the MTP triggers the ECC fault reporting.

Initial competitor self-test

In order to ensue the diagnostic competitor is normal, NEX13120-Q100 integrates self-test function during power-up, if competitor is abnormal, NEX13120-Q100 will pull the $\overline{\text{FLT}}$ pin down with pulsed current sink for 50 μs to report the fault and set registers including FLAG_CMP and FLAG_ERR to 1. Writing 1 to CLR_ERR can clear FLAG_CMP and FLAG_ERR.

Fault masking

NEX13120-Q100 provides fault masking capability using masking registers. The device is capable of masking faults by channels or by fault types. The fault masking does not disable diagnostics features but only prevents fault reporting to FLAG_OUT register, FLAG_ERR register, and $\overline{\text{FLT}}$ pin output. The below table lists the detailed description for each fault mask register in NORMAL state. To disable diagnostics on a single channel, setting CONF_DIAGENCHn registers to 0 disables open-circuit, LED short-circuit and single-LED short circuit diagnostics of channel n and thus no fault of this channel is reported to FLAG_OPENCHn, FLAG_SHORTCHn, FLAG_ODDIAGCHn, FLAG_OUT or FLAG_ERR registers, or to the $\overline{\text{FLT}}$ pin output.

Table 16. Fault masking in NORMAL state

Fault detected	Mask register	FLAG name	FLT pin
Vs Low warning	CONF_MASKLOWVS=1	FLAG_LOWVS=1	No action
	CONF_MASKLOWVS=0	FLAG_LOWVS=1 FLAG_ERR=1	One pulse pulled down for 50 μs
Vs undervoltage	CONF_MASKVSUV=1	FLAG_VSUV=1	No action
	CONF_MASKVSUV=0	FLAG_VSUV=1 FLAG_ERR=1	Constant pulled down
Reference fault	CONF_MASKREF=1	FLAG_REF=1	No action
	CONF_MASKREF=0	FLAG_REF=1 FLAG_ERR=1	Constant pulled down

Fault detected	Mask register	FLAG name	FLT pin
Pre-thermal warning	CONF_MASKPRETSD=1	FLAG_PRETSD=1	No action
	CONF_MASKPRETSD=0	FLAG_PRETSD=1 FLAG_ERR=1	One pulse pulled down for 50 μ s
Overtemperature protection	CONF_MASKTSD=1	FLAG_TSD=1	No action
	CONF_MASKTSD=0	FLAG_TSD=1 FLAG_ERR=1	Constant pulled down
MTPROMCRC error	CONF_MASKMTPCRC=1	FLAG_MTPCRC=1	No action
	CONF_MASKMTPCRC=0	FLAG_MTPCRC=1 FLAG_ERR=1	One pulse pulled down for 50 μ s
LED open-circuit fault	CONF_MASKOPEN=1	FLAG_OPENCHn=1	No action
	CONF_MASKOPEN=0	FLAG_OPENCHn=1 FLAG_OUT=1 FLAG_ERR=1	One pulse pulled down for 50 μ s
LED short-circuit fault	CONF_MASKSHORT= 1	FLAG_SHORTCHn= 1	No action
	CONF_MASKSHORT= 0	FLAG_SHORTCHn= 1 FLAG_OUT=1 FLAG_ERR=1	One pulse pulled down for 50 μ s
Auto Single LED short-circuit fault	CONF_MASKSLS=1	FLAG_ODDIAGCHn=1	No action
	CONF_MASKSLS=0	FLAG_ODDIAGCHn=1 FLAG_OUT=1 FLAG_ERR=1	One pulse pulled down for 50 μ s

Table 17. Diagnostics in Normal state

Fault type	Detection criteria	Conditions and method	Fault actions	Fault output	Fault pin	Recovery
VBAT UVLO Base on comparator	$V_{(Vbat)} < V_{(POR_fall)}$	Comparator	Device switch to POR state	FLAG_POR FLAG_ERR	Constant pulled down	Device switch to INIT state when all voltage rails are good. Clear fault flag with CLR_POR
VLDO UVLO Base on comparator	$V_{(VLDO)} < V_{(VLDO_POR_fall)}$	Comparator	Device switch to POR state	FLAG_POR FLAG_ERR	Constant pulled down	Device switch to INIT state when all voltage rails are good. Clear fault flag with CLR_POR
VLDO OV	$V_{(VLDO)} > V_{(VLDO_OV_rise)}$	Comparator	No action	FLAG_LDOOV FLAG_ERR	Constant pulled down	Automatically recovery upon fault removal Clear fault flag with CLR_ERR
Low Vs warning	$V_s < V_{(ADCLOWVSTH)}$	ADC	Disable fault type *	FLAG_LOWVS FLAG_ERR (maskable)	One pulse pulled down for 50 μ s (maskable)	Clear fault flag with CLR_ERR
Vs undervoltage	$V_s < V_{(Vs_th_fall)}$	Comparator or ADC(CONF_AUTOSS = 1)	Turn off all outputs	FLAG_VSUUV FLAG_LOWVS FLAG_ERR (maskable)	Constant pulled down(maskable)	Automatically recovery and release FLT pin upon fault removal Clear fault flag with CLR_ERR
Reference fault	$V_{(REF)} < V_{(REF_SHORT_th)}$ or $I_{(REF)} < I_{(REF_OPEN_th)}$	Comparator or ADC(CONF_AUTOSS = 1)	No action	FLAG_REF FLAG_ERR (maskable)	Constant pulled down(maskable)	Automatically release FLT pin upon fault removal Clear fault flag with CLR_ERR
Pre-thermal warning	$T_j > T_{(PRETSD)}$	Comparator or ADC(CONF_AUTOSS = 1)	No action	FLAG_PRETSD	One pulse pulled down for 50 μ s (maskable)	Clear fault flag with CLR_ERR
Overtemperature protection	$T_j > T_{(TSD1)}$	Comparator or ADC(CONF_AUTOSS = 1)	Turn off all outputs	FLAG_PRETSD FLAG_TSD FLAG_ERR (maskable)	Constant pulled down(maskable)	Automatically recover upon fault removal Clear fault flag with CLR_ERR
Overtemperature shutdown	$T_j > T_{(TSD2)}$	Comparator	Turn off LDO	FLAG_PORFLAG_ERR	Constant pulled down	Device switch to INIT state when all voltage rails are good Clear fault flag with CLR_POR
LED open-circuit fault *	$V_s - V_{(OUTn)} < V_{(OPEN_th_rise)}$ and $V_s > V_{(LOWVSTH)}$	PWM pulse width greater than $t_{(ODPW)}$ CONF_ENCHn = 1 CONF_DIAGENCHn = 1 Comparator or ADC(CONF_AUTOSS = 1)	No action	FLAG_OPENCHn FLAG_OUT (maskable) FLAG_ERR (maskable)	Onepulse pulled down for 50 μ s (maskable)	Clear fault flag with CLR_ERR

Fault type	Detection criteria	Conditions and method	Fault actions	Fault output	Fault pin	Recovery
LED short-circuit fault	$V_{(OUTn)} < V_{(SG_th_rise)}$	PWM pulse width greater than $t_{(ODPW)}$ CONF_ENCHn = 1 CONF_DIAGENCHn = 1 Comparator or ADC(CONF_AUTOSS = 1)	No action	FLAG_SHORTCHn FLAG_OUT (maskable) FLAG_ERR (maskable)	One pulse pulled down for 50 μ s (maskable)	Clear fault flag with CLR_ERR
On-demand off-state invisible diagnostic	LED Open-circuit or LED Short-circuit fault	Pulse width: $T_{(ODPW)}$ Current: $I_{(ODIOUT)}$ CONF_ENCHn = 0 CONF_DIAGENCHn = 1 CONF_INVDIAGSTART = 1	No action	FLAG_ODREADY FLAG_ODDIAGCHn FLAG_OUT FLAG_ERR FLAG_OPENCHn or FLAG_SHORTCHn	One pulse pulled down for 50 μ s	Clear fault flag with CLR_ERR
On-demand off-state single-LED Short-circuit *	$V_{(OUTn)} < V_{(ADCSHORTTH)}$ and $V_s > V_{(ADCLOWVSTH)}$	Pulse width: $T_{(ODPW)}$ Current: $I_{(ODIOUT)}$ CONF_ENCHn = 0 CONF_DIAGENCHn = 1 CONF_SSSTART = 1 ADC	No action	FLAG_ODREADY FLAG_ODDIAGCHn FLAG_OUT FLAG_ERR	One pulse pulled down for 50 μ s	Clear fault flag with CLR_ERR
Auto single-LED short circuit *	$V_{(OUTn)} < V_{(ADCSHORTTH)}$ and $V_{(SUPPLY)} > V_{(ADCLOWVSTH)}$	PWM pulse width greater than $T_{(ODPW)} + 3 \times T_{(CONV)}$ CONF_ENCHn = 1 CONF_DIAGENCHn = 1 ADC(CONF_AUTOSS = 1)	No action	FLAG_ODDIAGCHn FLAG_OUT (maskable) FLAG_ERR (maskable)	One pulse pulled down for 50 μ s (maskable)	Clear fault flag with CLR_ERR
MTPROMCRC error	CALC_MTPCRC is different MTPCRC		No action	FLAG_MTPCRC FLAG_ERR (maskable)	One pulse pulled down for 50 μ s (maskable)	Clear fault flag with CLR_ERR
Communication loss fault	$T_{(WDTIMER)}$ overflows		Enter Fail-Safe states	FLAG_FS	No action	Set CLRFS to 1 to set the device to NORMAL state
ECC	ECC_ECNT \neq 0		No action	FLAG_ECC FLAG_ERR	One pulse pulled down for 50 μ s	Clear fault flag with CLR_ERR
Initial self-test	After CLR_POR, Comparator abnormal		No action	FLAG_CMP FLAG_ERR	One pulse pulled down for 50 μ s	Clear fault flag with CLR_ERR

14.3.7. Diagnostic and protection in FAIL-SAFE state

In FAIL-SAFE state, the NEX13120-Q100 also detects failures and reports the status out by $\overline{\text{FLT}}$ pin or FLAG registers. [Table 19](#) lists the summary of the fault detection criteria and the device behavior after the fault is detected. Basically, the NEX13120-Q100 actively takes the action to turn off the failed output channels, retry on the failed channels, or restart the device to keep device operating without controlled by master. The MTP register NV_OFAP can be used to set the fault behavior for LED open-circuit, LED short-circuit, and single-LED short-circuit faults. The one-fails-all-fail behavior is selected when the register NV_OFAP is burnt to 1; otherwise, the one-fails-others-on behavior is chosen. The NEX13120-Q100 turns off all output channels when any type of LED fault is detected on any one of output channels for one-fails-all-fail behavior. On the other hand, the NEX13120-Q100 only turns off the failed channel and keeps all other normal channels on. In FAIL-SAFE state, the fault flag registers of NEX13120-Q100 still can be accessed again through UART interface in case the communication is rebuilt.

Vbat and VLDO undervoltage lockout diagnostics in FAIL-SAFE state

When Vbat or VLDO voltage drops below its UVLO threshold, the device enters POR state. Upon voltage recovery, the device automatically switches to INIT state with FLAG_POR and FLAG_ERR set to 1.

Low Vs-supply warning diagnostics in FAIL-SAFE state

The NEX13120-Q100 continuously monitors the Vs voltage and compares the results with internal threshold $V_{(\text{LOWVSTH})}$ set by CONF_LOWVSTH for low-Vs voltage warning. If the supply voltage is lower than threshold, the device sets flag registers including FLAG_LOWVVS and FLAG_ERR to 1. The fault is latched in flag registers. When the supply voltage rises above low-Vs warning threshold, the master controller must write register CLR_ERR to 1 to reset FLAG_LOWVVS and FLAG_ERR. The CLR_ERR bit automatically returns to 0. The low-Vs warning is also used to disable the LED open-circuit detection and single-LED short-circuit detection. When the voltage applied on Vs pin is higher than the threshold $V_{(\text{LOWVSTH})}$, the NEX13120-Q100 enables LED open-circuit and single-LED short-circuit diagnosis. When Vs is lower than the threshold $V_{(\text{LOWVSTH})}$, the device disables LED-open-circuit detection and single-LED short-circuit diagnosis. Because when Vs drops below the maximum total LED forward voltage plus required $V_{(\text{OUT_drop})}$ at required current, the NEX13120-Q100 is not able to deliver sufficient current output to pull the voltage of each output channel as close as possible to the Vs. In this condition, the LED open-circuit fault or single-LED short circuit fault might be detected and reported by mistake. Setting the low-Vs warning threshold high enough can avoid the LED open-circuit and single LED short-circuit fault being detected when Vs drops too low. The $V_{(\text{LOWVSTH})}$ is programmable from 4 V to 19 V.

Vs undervoltage diagnostics in FAIL-SAFE State

The NEX13120-Q100 provides internal analog comparator to monitor the supply voltage for undervoltage protection in FAIL-SAFE state. If the supply voltage falls below the internal threshold, $V_{(\text{Vs_th_fall})}$, the device pulls the $\overline{\text{FLT}}$ pin low with constant current sink to report the fault and set flag registers including FLAG_VSUV and FLAG_ERR to 1. The supply undervoltage detection is used to disable all current output. When Vs is lower than the threshold $V_{(\text{Vs_th_fall})}$, the device disables every output to avoid the unwanted LED flickering or output fault triggered improperly. When the voltage applied on Vs pin rises above the threshold $V_{(\text{Vs_th_rise})}$, the NEX13120-Q100 enables all current outputs automatically. The fault is latched in flag registers. When the supply voltage rises above $V_{(\text{Vs_th_rise})}$, the NEX13120-Q100 releases $\overline{\text{FLT}}$ pin and the master controller must write register CLR_ERR to 1 to clear FLAG_VSUV and FLAG_ERR. The CLR_ERR bit automatically returns to 0.

Reference diagnostics in FAIL-SAFE state

NEX13120-Q100 integrates diagnostics for REF resistor open and short fault in FAIL-SAFE state. The device monitors the reference current $I_{(\text{REF})}$ set by external resistor $R_{(\text{REF})}$. Use [Equation 6](#) to calculate the $I_{(\text{REF})}$. If the current output from REF pin $I_{(\text{REF})}$ is lower than $I_{(\text{REF_OPEN_th})}$, the reference resistor open-circuit fault is reported. The reference resistor short-circuit fault is reported if the voltage of REF pin $V_{(\text{REF})}$ is lower than $V_{(\text{REF_SHORT_th})}$. The device pulls the $\overline{\text{FLT}}$ pin down with constant current sink and sets flag registers including FLAG_REF and FLAG_ERR to 1. The fault is latched in flag registers.

After the REF pin $I_{(\text{REF})}$ and $V_{(\text{REF_SHORT_th})}$ recover to normal, the device releases $\overline{\text{FLT}}$ pin pull-down automatically and the master controller must send CLR_ERR to clear FLAG_REF and FLAG_ERR. The CLR_ERR automatically returns to

0. In FAIL-SAFE state, the device turns off all output channels when reference fault is detected. The device automatically recovers and turns on all enabled channels after fault removal.

Pre-thermal warning in FAIL-SAFE state

The NEX13120-Q100 has pre-thermal warning at typical 135 °C in FAIL-SAFE state. When the junction temperature T_j of NEX13120-Q100 rises above pre-thermal warning threshold, the device reports pre-thermal warning and sets the flag registers including FLAG_PRETSD and FLAG_ERR to 1. The fault is latched in flag registers. When the junction temperature of NEX13120-Q100 falls below pre-thermal warning threshold, the master controller must write 1 to CLR_ERR register to clear FLAG_PRETSD and FLAG_ERR. The CLR_ERR bit automatically returns to 0.

Overtemperature protection in FAIL-SAFE state

The NEX13120-Q100 has overtemperature protection at $T_{(TSD1)}$, typical 175 °C in FAIL-SAFE state. When device junction temperature T_j further rises above overtemperature protection threshold, the device turns off all output drivers, pulls the \overline{FLT} pin low with constant current sink to report fault, and sets the flag registers including FLAG_TSD and FLAG_ERR to 1. The fault is latched in flag registers. When the junction temperature falls below $T_{(TSD1)} - T_{(TSD1_HYS)}$, the device resumes all outputs and releases \overline{FLT} pin pull-down. The master controller must write 1 to CLR_ERR to clear FLAG_TSD and FLAG_ERR. The CLR_ERR bit automatically returns to 0.

Overtemperature shutdown in FAIL-SAFE state

When the T_j rises too high above $T_{(TSD2)}$, typically 180 °C, the NEX13120-Q100 turns off the internal linear regulator, VLDO output to shut down all the analog and digital circuits. The \overline{FLT} pin is pulled down by constant current sink to report the fault, and the FLAG_POR and FLAG_ERR are all set to 1. When the T_j drops below $T_{(TSD2)} - T_{(TSD2_HYS)}$, the NEX13120-Q100 restarts from POR state with all the registers cleared to default value and \overline{FLT} pin released. The master controller must write 1 to CLR_POR to clear both FLAG_POR and FLAG_ERR after fault removal. The CLR_POR bit automatically returns to 0.

LED open-circuit diagnostics in FAIL-SAFE state

The NEX13120-Q100 integrates LED open-circuit diagnostics to allow users to monitor LED status real time in FAIL-SAFE state. The device monitors voltage difference between V_s and OUT_n to judge if there is any open-circuit failure. The V_s voltage is also monitored in parallel with programmable threshold to determine if supply voltage is high enough for open-circuit diagnostics. The open-circuit monitor is only effective during PWM-ON state with programmable minimal pulse width greater than $t_{(ODPW)}$. The $t_{(ODPW)}$ is programmed by register ODPW. If PWM on-time is less than $t_{(ODPW)}$, the device does not report any open-circuit fault. When the device supply voltage V_s is below the threshold $V_{(LOWVSTH)}$ set by register CONF_ADCLOWVSTH, the LED open-circuit fault is not detected nor reported. When the voltage difference $V_s - V_{(OUT_n)}$ is below threshold $V_{(OPEN_th_rise)}$ with duration longer than $t_{(ODPW)}$, and the device supply voltage V_s is above the threshold $V_{(LOWVSTH)}$, the NEX13120-Q100 pulls the \overline{FLT} pin down with constant current sink to report fault and set flag registers including FLAG_OPENCH_n, FLAG_OUT and FLAG_ERR to 1. In FAIL-SAFE state, the NEX13120-Q100 shuts down the normal current regulation and PWM duty cycle for the error output, then the device sources a current $I_{(RETRY)}$ to faulty output every $t_{(retry)}$, typically 10ms for retrying. $I_{(RETRY)}$ is programmed by CONF_IOUT register. The current $I_{(RETRY)}$ can be calculated with the below equation. When the voltage difference $V_s - V_{(OUT_n)}$ of error output rises above threshold $V_{(OPEN_th_rise)}$ with duration longer than $t_{(ODPW)}$, or the supply voltage V_s is above the threshold $V_{(LOWVSTH)}$, the device automatically resumes the normal current and PWM duty cycle setup and releases the \overline{FLT} pin.

The fault is latched in flag registers. When the open-circuit failure is removed, the master controller must write 1 to CLR_ERR to clear FLAG_OPENCH_n, FLAG_OUT and FLAG_ERR. The CLR_ERR bit automatically returns to 0.

LED short-circuit diagnostics in FAIL-SAFE state

The NEX13120-Q100 has internal analog comparators to monitor all channel outputs with respect to a fixed threshold for reporting OUT_n short to GND fault in FAIL-SAFE state. The short-circuit detection is only effective during PWM-ON state with programmable minimal pulse width of $t_{(ODPW)}$. The $t_{(ODPW)}$ is programmable by register ODPW. If PWM on-time is less than $t_{(ODPW)}$, the device cannot report any short-circuit fault. When the voltage $V_{(OUT_n)}$ is below threshold $V_{(SG_th_fall)}$ with duration longer than deglitch timer length of $t_{(ODPW)}$, the device pulls \overline{FLT} pin down with constant current sink to report fault and set flag registers including FLAG_SHORTCH_n, FLAG_OUT and FLAG_ERR. In FAIL-SAFE state, the NEX13120-Q100 shuts down the normal current regulation and PWM duty cycle for the faulty output, then the device sources a pulse current to faulty output every $t_{(retry)}$, 10 ms for retrying. $I_{(RETRY)}$ is programmed by CONF_ODIOUT register. Use Equation 8 to calculate the current, $I_{(RETRY)}$. When the voltage $V_{(OUT_n)}$ of error output rises above threshold $V_{(SG_th_rise)}$ with duration longer than $t_{(ODPW)}$, the device automatically resumes the normal current and PWM duty cycle setup and releases the \overline{FLT}

pin. The fault is latched in flag registers. When the short-circuit failure is removed, the master controller must write 1 to CLR_ERR to clear FLAG_SHORTCHn, FLAG_OUT and FLAG_ERR. The CLR_ERR bit automatically returns to 0.

Single-LED short-circuit detection in FAIL-SAFE state

The NEX13120-Q100 also integrates analog comparators to monitor all outputs with respect to two alternative threshold for single-LED short-circuit diagnostic in FAIL-SAFE state. Setting the register CONF_AUTOSS to 1 enables the single-LED short-circuit detection. The single-LED short-circuit detection is only effective during PWM-ON state with programmable minimal pulse width of $t_{(ODPW)}$. The $t_{(ODPW)}$ is programmable by register ODPW. If PWM on-time is less than $t_{(ODPW)}$, the device cannot report any single-LED short-circuit fault. When the device supply voltage V_s is below the threshold $V_{(LOWVSTH)}$ set by register CONF_ADCLOWVSTH, the single-LED short-circuit is not detected nor reported. When the voltage $V_{(OUTn)}$ is below threshold $V_{(ADCSHORTTHn)}$ with duration longer than deglitch timer length of $t_{(ODPW)}$, and the device supply voltage V_s is above the threshold $V_{(LOWVSTH)}$, the device pulls the \overline{FLT} pin down with constant current sink to report fault and set flag registers including FLAG_ODDIAGCHn, FLAG_OUT and FLAG_ERR. The NEX13120-Q100 provides two alternative threshold $V_{(ADCSHORTTH0)}$ and $V_{(ADCSHORTTH1)}$ for single-LED short-circuit detection selected by ADCSHORTTHCHn independently for each current output. The $V_{(ADCSHORTTH0)}$ is selected for current OUTn when ADCSHORTTHCHn is set to 0, however $V_{(ADCSHORTTH1)}$ is selected when ADCSHORTTHCHn is set to 1. The actual voltage value for $V_{(ADCSHORTTH0)}$ and $V_{(ADCSHORTTH1)}$ is programmable by two 8 bit registers CONF_ADCSHORTTH0 and CONF_ADCSHORTTH1 from 0V to 20.56 V at 80 mV interval. In FAIL-SAFE state, the NEX13120-Q100 shuts down the normal current regulation and PWM duty cycle for the faulty output, then the device sources a pulse current, $I_{(OUTn)}$ programed by IOUTn register to the faulty output every $t_{(retry)}$, 10 ms for retrying. When the voltage $V_{(OUTn)}$ of error output rises above threshold $V_{(ADCSHORTTHn)} + 125$ mV with duration longer than $t_{(ODPW)}$ during retrying, or the supply voltage V_s is below the threshold $V_{(LOWVSTH)}$, the device automatically resumes the normal current and PWM duty cycle setup and releases the \overline{FLT} pin. The fault is latched in flag registers. When the single-LED short-circuit fault is removed, the master controller must write 1 to register CLR_ERR to clear FLAG_ODDIAGCHn, FLAG_OUT and FLAG_ERR. The CLR_ERR automatically returns to 0.

MTP CRC error in FAIL-SAFE state

The NEX13120-Q100 automatically reloads all MTP code into the corresponding configuration registers every time after entering the FAIL-SAFE state. The NEX13120-Q100 implements a MTP CRC check after loading the MTP code to configuration register in FAIL-SAFE state. The calculated CRC results are sent to register CALC_MTPCRC and compared to the data in MTP register NV_CRC, which stores the CRC code for all MTP registers. If the code in register CALC_MTPCRC is not matched to the code in register NV_CRC, the NEX13120-Q100 turns off all channels output, pulls the FLT pin down with constant current sink to report the fault, and sets the registers including FLAG_MTPCRC and FLAG_ERR to 1. The CRC code for all the MTP registers must be burnt into MTP register MTPCRC in the end of production line. The CRC code algorithm is described in MTP CRC Error in NORMAL state.

Fault masking in FAIL-SAFE state

The NEX13120-Q100 provides fault masking capability using masking registers. The device is capable of masking faults by channels or by fault types. The fault masking does not disable diagnostics features but only prevents fault reporting to FLAG_OUT register, FLAG_ERR register, and \overline{FLT} pin output. The below table gives the detailed description for each fault mask register in NORMAL state.

To disable diagnostics on a single channel in FAIL-SAFE state, burning MTP of NV_DIAGENCHn registers to 0 disables open-circuit, LED short-circuit diagnostics of channel n, and thus no fault of this channel is reported to FLAG_OPENCHn, FLAG_SHORTCHn, FLAG_OUT or FLAG_ERR registers, or to the \overline{FLT} pin output.

Table 18. Fault masking register in NORMAL state

Fault detected	Mask register	FLAG name	FLT pin
Vs Low warning	CONF_MASKLOWVS = 1	FLAG_LOWVS = 1	No action
	CONF_MASKLOWVS = 0	FLAG_LOWVS = 1 FLAG_ERR = 1	Constant pulled down
Vs undervoltage	CONF_MASKVSUV = 1	FLAG_VSUV = 1	No action
	CONF_MASKVSUV = 0	FLAG_VSUV = 1 FLAG_ERR = 1	Constant pulled down

Fault detected	Mask register	FLAG name	FLT pin
Reference fault	CONF_MASKREF = 1	FLAG_REF = 1	No action
	CONF_MASKREF = 0	FLAG_REF = 1 FLAG_ERR = 1	Constant pulled down
MTPROMCRC error	CONF_MASKMTPCRC = 1	FLAG_MTPCRC = 1	No action
	CONF_MASKMTPCRC = 0	FLAG_MTPCRC = 1 FLAG_ERR = 1	Constant pulled down
LED open-circuit fault	CONF_MASKOPEN = 1	FLAG_OPENCHn = 1	No action
	CONF_MASKOPEN = 0	FLAG_OPENCHn = 1 FLAG_OUT = 1 FLAG_ERR = 1	Constant pulled down
LED short-circuit fault	CONF_MASKSHORT= 1	FLAG_SHORTCHn = 1	No action
	CONF_MASKSHORT= 0	FLAG_SHORTCHn = 1 FLAG_OUT = 1 FLAG_ERR = 1	Constant pulled down
Overtemperature protection	CONF_MASKTSD = 1	FLAG_TSD=1	No action
	CONF_MASKTSD = 0	FLAG_TSD = 1 FLAG_ERR = 1	Constant pulled down

Table 19. Diagnostics table in FAIL-SAFE state

Fault type	Detection criteria	Conditions and method	Fault actions	Fault output	FLT pin	Recovery
VBAT UVLO Base on comparator	$V_{(Vbat)} < V_{(POR_fall)}$	Comparator	Device switch to POR state	FLAG_POR FLAG_ERR	Constant pulled down	Device switch to INIT state when all voltage rails are good. Clear fault flag with CLR_POR.
VLDO UVLO Base on comparator	$V_{(VLDO)} < V_{(VLDO_POR_fall)}$	Comparator	Device switch to POR state	FLAG_POR FLAG_ERR	Constant pulled down	Device switch to INIT state when all voltage rails are good. Clear fault flag with CLR_POR.
Low-Vs warning	$V_s < V_{(LOWVSTH)}$	ADC	Disable fault type*	FLAG_LOWVS FLAG_ERR (maskable)	No action	Clear fault flag with CLR_ERR.
Vs undervoltage	$V_s < V_{(Vs_th_fall)}$	Comparator	Turn off all outputs	FLAG_VSUUV FLAG_ERR (maskable)	Constant pulled down (maskable)	Automatically recovery and release FLT pin upon fault removal. Clear fault flag with CLR_ERR.
Reference fault	$V_{(REF)} < V_{(REF_SHORT_th)}$ or $I_{(REF)} < I_{(REF_OPEN_th)}$	Comparator	Turn off all outputs	FLAG_REF FLAG_ERR (maskable)	Constant pulled down (maskable)	Automatically recover and release FLT pin upon fault removal. Clear fault flags with CLR_ERR.
Overtemperature protection	$T_j > T_{(TSD1)}$	Comparator	Turn off all outputs	FLAG_TSD FLAG_ERR (maskable)	Constant pulled down (maskable)	Automatically recover and release FLT pin upon fault removal. Clear fault flags with CLR_ERR.
Overtemperature shutdown	$T_j > T_{(TSD2)}$	Comparator	Turn off VLDO	FLAG_POR FLAG_ERR	Constant pulled down	Device switch to INIT state when all voltage rails are good. Clear fault flag with CLR_POR.
LED open-circuit fault *	$V_s - V_{(OUTn)} < V_{(OPEN_th_rise)}$ and $V_s > V_{(LOWVSTH)}$	PWM pulse width greater than $t_{(ODPW)}$ CONF_ENCHn = 1 CONF_DIAGENCHn = 1	Turn off the failed outputs and retry every 10 ms	FLAG_OPENCHn FLAG_OUT (maskable) FLAG_ERR (maskable)	Constant pulled down (maskable)	Automatically recover and release FLT pin upon fault removal. Clear fault flags with CLR_ERR.
LED short-circuit fault	$V_{(OUTn)} < V_{(SG_th_rise)}$	PWM pulse width greater than $t_{(ODPW)}$ CONF_ENCHn = 1 CONF_DIAGENCHn = 1	Turn off the failed outputs and retry every 10 ms	FLAG_SHORTCHn FLAG_OUT (maskable) FLAG_ERR (maskable)	Constant pulled down (maskable)	Automatically recover and release FLT pin upon fault removal. Clear fault flags with CLR_ERR.
MTP CRC error	CALC_MTPCRC is different MTPCRC		Turn off all outputs	FLAG_MTPCRC FLAG_ERR (maskable)	Constant pulled down (maskable)	Clear fault flags with CLR_ERR.

14.3.8. OFAF setup in FAIL-SAFE state

The NEX13120-Q100 has a unique setup for failure behavior in FAIL-SAFE state. If there is a failure detected in FAIL-SAFE state, the NEX13120-Q100 automatically reacts to the failure. The register OFAF determines whether the result behavior of output failure is one-fails-all-fail or one-fails-others-on.

In FAIL-SAFE state, the NEX13120-Q100 shuts down all enabled current outputs except the faulty output when OFAF is set to 1. Otherwise, the NEX13120-Q100 keeps regulation for all enable current outputs except the faulty output when OFAF is set to 0. [Table 20](#) provides details.

14.3.9. $\overline{\text{FLT}}$ Output

The $\overline{\text{FLT}}$ pin is a programmable fault indicator pin. This pin can be used as an interrupt output to master controller in case there is any fault in NORMAL state. In FAIL-SAFE states, the $\overline{\text{FLT}}$ pin can be used as an output to other $\overline{\text{FLT}}$ pin of other NEX13120-Q100 to achieve one-fails-all-fail at system level. The $\overline{\text{FLT}}$ pin is an open-drain output with current limit up to $I_{\text{PD(ERR)}}$. Nexperia recommends a $< 10 \text{ k}\Omega$ external pull-up resistor from the $\overline{\text{FLT}}$ pin to the same IO voltage of the master controller.

In NORMAL state, when a fault is triggered, depending on the fault type, the $\overline{\text{FLT}}$ pin is either pulled down constantly or pulled down for a single pulse. After an $\overline{\text{FLT}}$ output is triggered, the master controller must take action to deal with the failure and reset the fault flag. For non-critical faults, the NEX13120-Q100 pulls down the $\overline{\text{FLT}}$ pin with a duration of 50 μs and release; for critical faults, device constantly pulls down $\overline{\text{FLT}}$ as described in [Table 17](#). In NORMAL state, basically, the NEX13120-Q100 only reports the faults to the master controller for most of the failure and takes no actions except supply or LDO UVLO, reference fault, and overtemperature. The master controller determines what action to take according to the type of the failure.

The NEX13120-Q100 provides a forced-error feature to validate the error feedback-loop integrity in NORMAL state. In NORMAL state, if the microcontroller sets FORCEERR to 1, the FLAG_ERR is set 1 and pulls down $\overline{\text{FLT}}$ output with a pulse of 50 μs accordingly. The FORCEERR automatically returns to 0.

In FAIL-SAFE states, the $\overline{\text{FLT}}$ pin is used as fault bus. When there is any output failure reported, the $\overline{\text{FLT}}$ is pulled down by internal current sink $I_{\text{PD(ERR)}}$. The NEX13120-Q100 monitors the voltage of the $\overline{\text{FLT}}$ pin. If the one-fails-all-fail diagnostics is enabled by setting register OFAF to 1, all current output channels are turned off, as well as diagnostics, when the $\overline{\text{FLT}}$ pin voltage is low. If register OFAF is 0, the device only turns off the failed channel with alive channels diagnostics enabled.

Table 20. One-Fails-All-Fail feature in Fail-Safe state

$\overline{\text{FLT}}$ pin	OFAF = 1	OFAF = 0
$\overline{\text{FLT}}$ pulled low internally	All OUT channel OFF except failure detected OUT retries every 10 ms	Only failure detected OUT OFF
$\overline{\text{FLT}}$ pulled low externally	All OUT channel OFF	All OUT channel ON

If multiple NEX13120-Q100 devices are used in one application, tying the $\overline{\text{FLT}}$ pins together achieves the one-fails-all-fail behavior in FAIL-SAFE states without master controlling. Any one of NEX13120-Q100 reports fault by pulling the $\overline{\text{FLT}}$ pin to low, and the low voltage on ERR bus is detected by other NEX13120-Q100 as [Fig. 39](#) illustrated. If the register OFAF is set to 1 for all NEX13120-Q100 devices having the $\overline{\text{FLT}}$ pins tied together, all NEX13120-Q100 devices turn off current for all output channels.

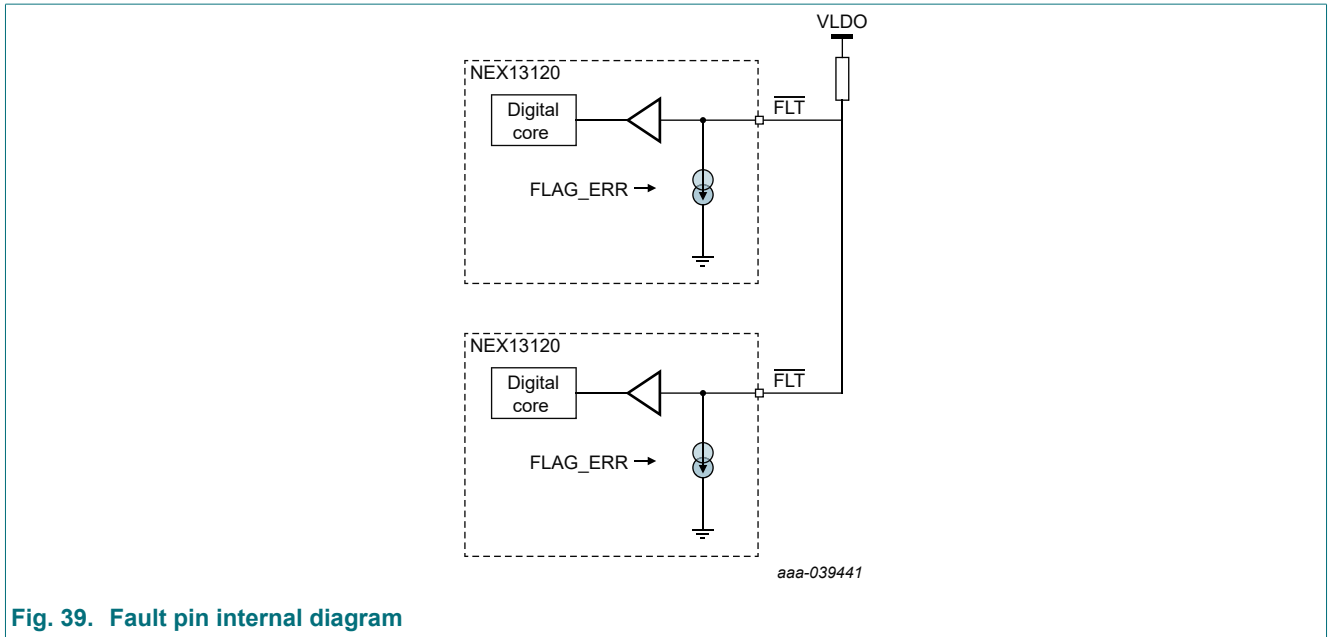

Fig. 39. Fault pin internal diagram

14.4. Device functional modes

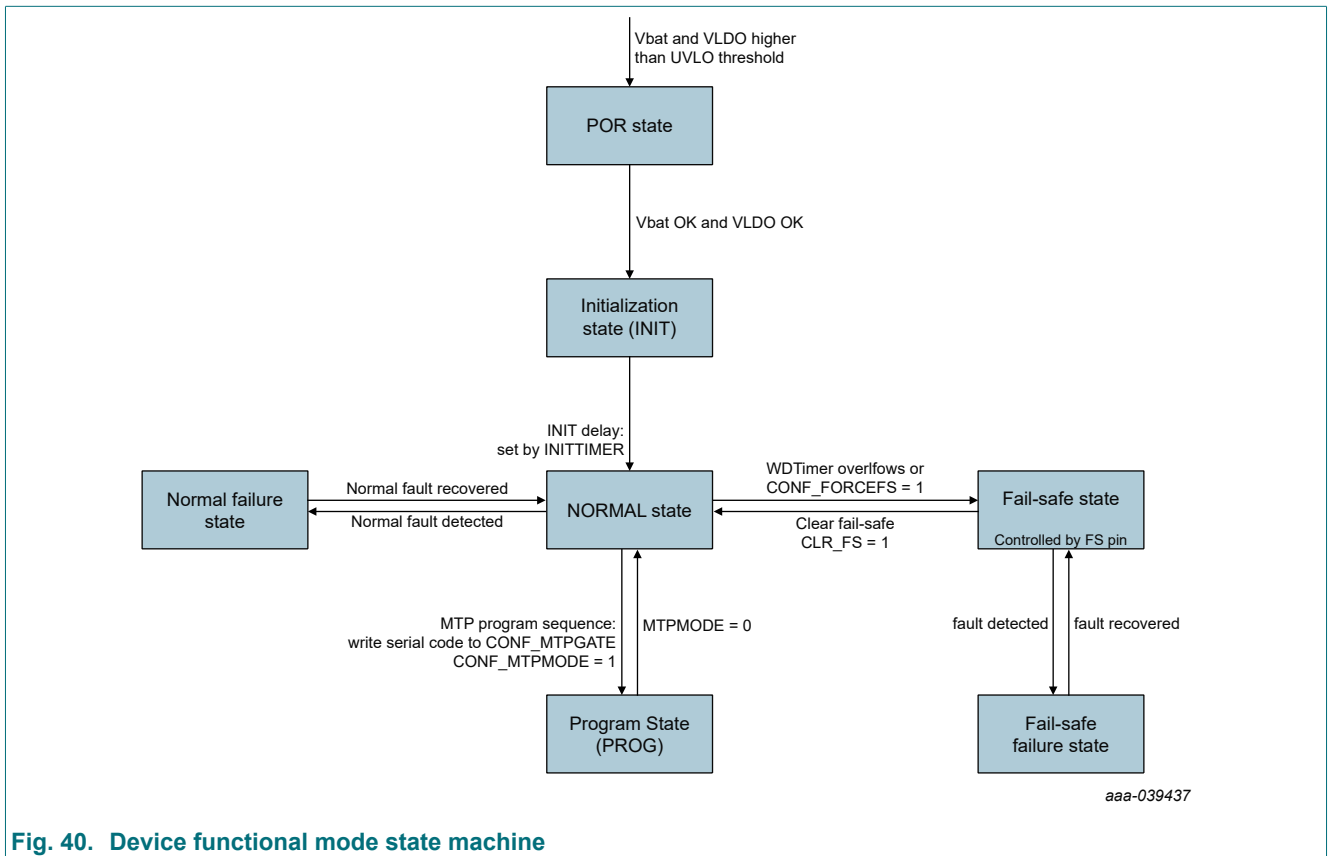

Fig. 40. Device functional mode state machine

14.4.1. POR state

Upon power up, the NEX13120-Q100 enters POWER_ON_RESET (POR) state. In this state, registers are cleared to default value, outputs are disabled, and the device cannot be accessed through the UART interface. After both the Vbat input and

the VLDO output are above their UVLO threshold, the device switches to INITIALIZATION state (INIT). If any of the supply fails below UVLO threshold in other states, the device immediately switches to POR state.

14.4.2. INITIALIZATION state

The INITIALIZATION state is designed to allow master controller to have enough time to power up before the device automatically gets into FAIL-SAFE states. INIT mode has a configurable delay programmed by 4-bit register NV_INITTIMER. After the delay counter is reached, the device changes to NORMAL state. In INIT state, the communication between master controller and the NEX13120-Q100 is enabled through UART interface. In INITIALIZATION state, device automatically load register map default values, which can be programmed in corresponding MTP. The master controller sets CLR_POR to 1 in INITIALIZATION state, the device immediately switches to NORMAL state. Only write CLR_POR to NEX13120-Q100 in INITIALIZATION state.

14.4.3. NORMAL state

After the NEX13120-Q100 is in NORMAL state, the device operates under master control for LED animation and diagnostics using UART interface. The NEX13120-Q100 integrates a watchdog timer to monitor the communication on UART interface. The watchdog timer is programmable by a 4-bit register CONF_WDTIMER for 13 options. The timer in NEX13120-Q100 starts to count when there is no instruction received from the master controller.

The NEX13120-Q100 enters FAIL-SAFE states when the timer overflows. The device can be also forced into FAIL-SAFE states anytime in NORMAL state by setting FORCEFS to 1. The FORCEFS register automatically returns to 0.

14.4.4. FAIL-SAFE state

When the NEX13120-Q100 is entering FAIL-SAFE state from NORMAL state, all the registers are set to default value or reloaded from MTP. The UART interface keeps alive in FAIL-SAFE state. Setting CONF_FORCEFS to 1 forces the device into FAIL-SAFE state from NORMAL state. The NEX13120-Q100 can quit from FAIL-SAFE state to NORMAL state by setting CLR_FS to 1 with FLAG_FS register cleared.

14.4.5. PROGRAM state

The NEX13120-Q100 can enter MTP PROGRAM state by writing multiple configuration registers to CONF_NVGATE and setting 1 to CONF_NVMODE. For details of getting into PROGRAM state, refer to MTP Programming.

14.4.5.1. UART over CAN protocol

NEX13120-Q100 integrates UART compliant controller, the structure is showed in Fig. 41. NEX13120-Q100 is compliant with the UART, the data format is similar to UART. The signal input to NEX13120-Q100 is usually transferred from external CAN transceiver.

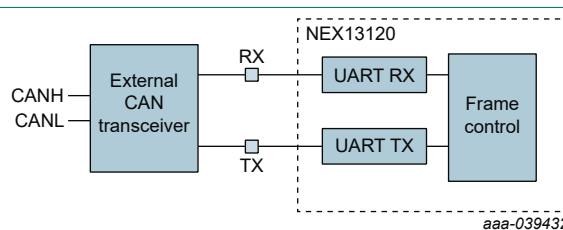

Fig. 41. Interface structure

The internal Frame controller is a UART-based protocol supported by most microcontroller units (MCU), Each frame contains multiple bytes started with a synchronization byte. The synchronization byte allows LED drivers to synchronize with master MCU frequency, therefore saving the extra cost on high precision oscillators that are commonly used in UART/CAN interfaces. Each byte has 1 start bit, 8 data bits, 1 stop bit, no parity check. The LSB data follows the start bit as below picture described. The interface supports adaptive communication frequency ranging from 50 kHz to 1 MHz. The protocol supports master-slave with star-connected topology.

UART interface slave address setting

NEX13120-Q100 supports maximum 27 slave devices. NEX13120-Q100 has three pin outs including ADDR2, ADDR1, and ADDR0 for slave address configuration. Different configurations allow NEX13120-Q100 support different slaves as below.

If NV_EXTADDR = 0, the device uses NV_DEVADDR [3] code together with external inputs on ADDR2, ADDR1 and ADDR0 to support 16 slaves as [Table 22](#).

If NV_EXTADDR = 1, ADDR2, ADDR1 and ADDR0 can support three statuses, include M status as listed in [Table 21](#). The device uses external inputs on ADDR2, ADDR1 and ADDR0 to set 27 slaves as shown in [Table 23](#), in this mode.

Table 21. Address pin status assessment

Status	Settings
0	Tie directly (0 Ω) to GND
M	Tie 30 kΩ to GND
1	Option 1: Tie 90 kΩ to GND Option 2: Tie directly to V _{CC}

Table 22. Address setting: NV_EXTADDR = 0

Address setting (NV_EXTADDR = 0)				
Address(Decimal)	Bit 3	Bit 2	Bit 1	Bit 0
	NV_DEVADDR [3]	ADDR2	ADDR1	ADDR0
0	0	0	0	0
1	0	0	0	1
2	0	0	1	0
3	0	0	1	1
4	0	1	0	0
5	0	1	0	1
6	0	1	1	0
7	0	1	1	1
8	1	0	0	0
9	1	0	0	1
10	1	0	1	0
11	1	0	1	1
12	1	1	0	0
13	1	1	0	1
14	1	1	1	0
15	1	1	1	1

Table 23. Address setting: NV_EXTADDR = 1

Address setting (NV_EXTADDR = 1)			
Address (Decimal)	ADDR2	ADDR1	ADDR0
0	0	0	0
1	0	0	1
2	0	1	0
3	0	1	1
4	1	0	0
5	1	0	1
6	1	1	0
7	1	1	1

Address setting (NV_EXTADDR = 1)			
Address (Decimal)	ADDR2	ADDR1	ADDR0
8	0	0	M
9	0	1	M
10	1	0	M
11	1	1	M
12	0	M	0
13	0	M	1
14	1	M	0
15	1	M	1
16	M	0	0
17	M	0	1
18	M	1	0
19	M	1	1
20	0	M	M
21	1	M	M
22	M	0	M
23	M	1	M
24	M	M	0
25	M	M	1
26	M	M	M

Burst mode and 27 slave configurations

NEX13120-Q100 support unique burst mode, by setting CONF_LENEXT to 0 or 1, user can select different burst mode. When CONF_LENEXT=0, burst mode supports 1 byte, 2 bytes, 4 bytes and 8 bytes; CONF_LENEXT=1, burst mode supports 1 byte, 4 bytes, 16 bytes and 24 bytes.

To support burst mode and 27 slave, user need to configure DEV_ADDR byte. The device address byte, DEV_ADDR frame follows the SYNC frame. There is total 8 bits binary code in device address byte. The detail definition for each bit function is described in below table. The DEV_ADDR register is required to set to 0000b for broadcast mode, otherwise the broadcast mode cannot be enabled. If burst mode is set to 16 or 24 bytes, NEX13120-Q100 only received first 12 bytes and CRC bytes, will ignore other data. For read, it still read 16 or 24 bytes.

Table 24. DEV_ADDR byte

Bit	Field	Description
3-0	DEVICE_ADDR	Target device address.
5-4	DATA_LENGTH	CONF_LENEXT = 0 00b: Single-byte mode with 1 byte of data; 01b: Bust mode with 2 bytes of data. 10b: Burst mode with 4 bytes of data; 11b: Burst mode with 8 bytes of data CONF_LENEXT = 1 00b: Single-byte mode with 1 byte of data; 01b: Bust mode with 4 bytes of data. 10b: Burst mode with 16 bytes of data; 11b: Burst mode with 24 bytes of data
6	BROADCAST	Broadcast mode. 1: Broadcast (DEVICE_ADDR =0000b); 0: Single-device only
7	READ/WRITE	Read/ Write mode. 1: Write mode; 0: Read mode

To support more than 16 slaves, we will use broadcast bit as address bit when slave address higher than 15, the details of DEV_ADDR byte for different slaves is listed in [Table 25](#).

Table 25. DEV_ADDR byte

DEV_ADDR byte				
Read/Write[7]	Broadcast[6]	Data_length [5:4]	Device_ADDR[3:0]	Read/Write slave
Write: 1 Read: 0	0	CONF_LENEXT = 0	1	slave 1
	0	00: 1 byte	2	slave 2
	0	01: 2 byte	3	slave 3
	0	10: 4 byte	4	slave 4
	0	11: 8 byte	5	slave 5
	0	CONF_LENEXT = 1	6	slave 6
	0	00: 1 byte	7	slave 7
	0	01: 4 byte	8	slave 8
	0	10: 16 byte	9	slave 9
	0	11: 24 byte	A	slave 10
	0		B	slave 11
	0		C	slave 12
	0		D	slave 13
	0		E	slave 14
	0		F	slave 15
	1		0	broadcast mode
	1		1	slave 16
	1		2	slave 17
	1		3	slave 18
	1		4	slave 19
	1		5	slave 20
	1		6	slave 21
	1		7	slave 22
	1		8	slave 23
	1		9	slave 24
	1		A	slave 25
1		B	slave 26	

14.4.5.2. MTP Programming

The NEX13120-Q100 has a user-programmable MTP with high reliability for automotive applications. All the MTP registers can be burnt through writing the target data into its corresponding register. The NEX13120-Q100 supports two solutions for individual chip selection through pulling the REF pin high or through device address configuration by address pin.

Chip selection by pulling REF pin high

The NEX13120-Q100 supports using REF pin as chip-select during MTP programming. Considering multiple NEX13240-Q100 devices connected on one UART bus before burning MTP, the slave address for all NEX13120-Q100 is all same before programming in case internal MTP register DEVADDR is used for slave address setup. The MTP burning instruction can be sent to target NEX13120-Q100 by pulling the REF pin of the target NEX13120-Q100 to 5 V. After the REF pin is pulled up to 5 V, the NEX13120-Q100 ignores the device address setup by ADDR2/ADDR1/ADDR0 pins or MTP programmed device address in DEVADDR.

The master controller must send out data to target NEX13120-Q100 with device address as 0h and not in broadcast mode.

Chip selection by ADDR pins configuration

The NEX13120-Q100 also supports using configuration on ADDR2/ADDR1/ADDR0 pins to determine the slave address for NEX13120-Q100 if multiple NEX13120-Q100 devices are connected on the same differential data bus.

Nexperia recommends using this approach for applications of multiple NEX13120-Q100 in the same differential data bus. The master controller can send out register data to target NEX13120-Q100 with device address matched to the ADDR2/ADDR1/ADDR0 pins configuration and not in broadcast mode.

MTP Register access and burn

After selecting the target NEX13120-Q100 for MTP burning, the master controller must send a serial data byte to register CONF_MTPGATE, set 1 to CONF_MTPMODE and set 1 to register CONF_STAYINMTP one by one to finally enable the MTP register access. For the detailed program sequence, please refer to file: ***NEX1312X-Q100 configuration guide and register map***.

MTP program state exit

The REF pin can be released after MTP burning if it is pulled high to 5 V for chip selection. The REF pin must be kept high during all MTP program state. The NEX13120-Q100 can quit the MTP program state to normal state after burning by writing 0 to register CONF_STAYINMTP. Nexperia recommends reloading the MTP data to the registers after MTP burning by set 1 to CLR_REG.

Reading back MTP

The NEX13120-Q100 supports MTP data reading back for both shadow registers and MTP cells. When the register CONF_READSHADOW is set to 1, reading back for certain MTP registers address returns shadow registers content. When the register CONF_READSHADOW is set to 0, reading back for certain MTP registers address returns content in MTP cell.

14.5. Normal register map and MTP register map

Normal register map

Table 26. Normal register map

ADDR	Name	BIT7	BIT6	BIT5	BIT4	BIT3	BIT2	BIT1	BIT0	Default
00h	IOUT0	Reserved	Reserved				CONF_IOUT0			NVI0
01h	IOUT1	Reserved	Reserved				CONF_IOUT1			NVI1
02h	IOUT2	Reserved	Reserved				CONF_IOUT2			NVI2
03h	IOUT3	Reserved	Reserved				CONF_IOUT3			NVI3
04h	IOUT4	Reserved	Reserved				CONF_IOUT4			NVI4
05h	IOUT5	Reserved	Reserved				CONF_IOUT5			NVI5
06h	IOUT6	Reserved	Reserved				CONF_IOUT6			NVI6
07h	IOUT7	Reserved	Reserved				CONF_IOUT7			NVI7
08h	IOUT8	Reserved	Reserved				CONF_IOUT8			NVI8
09h	IOUT9	Reserved	Reserved				CONF_IOUT9			NVI9
0Ah	IOUT10	Reserved	Reserved				CONF_IOUT10			NVI10
0Bh	IOUT11	Reserved	Reserved				CONF_IOUT11			NVI11
20h	PWM0					CONF_PWMOUT0				NVP0
21h	PWM1					CONF_PWMOUT1				NVP1
22h	PWM2					CONF_PWMOUT2				NVP2
23h	PWM3					CONF_PWMOUT3				NVP3
24h	PWM4					CONF_PWMOUT4				NVP4
25h	PWM5					CONF_PWMOUT5				NVP5
26h	PWM6					CONF_PWMOUT6				NVP6
27h	PWM7					CONF_PWMOUT7				NVP7
28h	PWM8					CONF_PWMOUT8				NVP8

ADDR	Name	BIT7	BIT6	BIT5	BIT4	BIT3	BIT2	BIT1	BIT0	Default
29h	PWM9	CONF_PWMOUT9								NVP9
2Ah	PWM10	CONF_PWMOUT10								NVP10
2Bh	PWM11	CONF_PWMOUT11								NVP11
3Ch	CONF_MISC13	CONF_ADCSHORTTH1[7:0]								NV16
3Dh	CONF_MISC14	CONF_ADCS_HORTTHCH7	CONF_ADCS_HORTTHCH6	CONF_ADCS_HORTTHCH5	CONF_ADCS_HORTTHCH4	CONF_ADCS_HORTTHCH3	CONF_ADCS_HORTTHCH2	CONF_ADCS_HORTTHCH1	CONF_ADCS_HORTTHCH0	NV17
3Eh	CONF_MISC15	Reserved	Reserved	Reserved	Reserved	CONF_ADCS_HORTTHCH11	CONF_ADCS_HORTTHCH10	CONF_ADCS_HORTTHCH9	CONF_ADCS_HORTTHCH8	NV18
3Fh	CONF_MISC16	Reserved	CONF_PS0[1:0]		Reserved					NV19
40h	PWML0	Reserved	Reserved	Reserved	Reserved	CONF_PWMLOWOUT0				0Fh
41h	PWML1	Reserved	Reserved	Reserved	Reserved	CONF_PWMLOWOUT1				0Fh
42h	PWML2	Reserved	Reserved	Reserved	Reserved	CONF_PWMLOWOUT2				0Fh
43h	PWML3	Reserved	Reserved	Reserved	Reserved	CONF_PWMLOWOUT3				0Fh
44h	PWML4	Reserved	Reserved	Reserved	Reserved	CONF_PWMLOWOUT4				0Fh
45h	PWML5	Reserved	Reserved	Reserved	Reserved	CONF_PWMLOWOUT5				0Fh
46h	PWML6	Reserved	Reserved	Reserved	Reserved	CONF_PWMLOWOUT6				0Fh
47h	PWML7	Reserved	Reserved	Reserved	Reserved	CONF_PWMLOWOUT7				0Fh
48h	PWML8	Reserved	Reserved	Reserved	Reserved	CONF_PWMLOWOUT8				0Fh
49h	PWML9	Reserved	Reserved	Reserved	Reserved	CONF_PWMLOWOUT9				0Fh
4Ah	PWML10	Reserved	Reserved	Reserved	Reserved	CONF_PWMLOWOUT10				0Fh
4Bh	PWML11	Reserved	Reserved	Reserved	Reserved	CONF_PWMLOWOUT11				0Fh
50h	CONF_EN0	CONF_ENCH7	CONF_ENCH6	CONF_ENCH5	CONF_ENCH4	CONF_ENCH3	CONF_ENCH2	CONF_ENCH1	CONF_ENCH0	00h
51h	CONF_EN1	Reserved	Reserved	Reserved	Reserved	CONF_ENCH11	CONF_ENCH10	CONF_ENCH9	CONF_ENCH8	00h

ADDR	Name	BIT7	BIT6	BIT5	BIT4	BIT3	BIT2	BIT1	BIT0	Default
54h	CONF_D IAGEN0	CONF_DIAGEN CH7	CONF_DIAGEN CH6	CONF_DIAGEN CH5	CONF_DIAGEN CH4	CONF_DIAGEN CH3	CONF_DIAGEN CH2	CONF_DIAGEN CH1	CONF_DIAGEN CH0	NV4
55h	CONF_D IAGEN1	Reserved	Reserved	Reserved	Reserved	CONF_DIAGEN CH11	CONF_DIAGEN CH10	CONF_DIAGEN CH9	CONF_DIAGEN CH8	NV5
56h	CONF_MISC0	CONF_AUTOSS	Reserved(R/W)	Reserved(R)	CONF_EXPEN	Reserved(R/W)				NV6
57h	CONF_MISC1	CONF_PWMFREQ				Reserved		CONF_REFRANGE		NV7
58h	CONF_MISC2	Reserved	CONF_FLTIMEOUT			CONF_ADCLOWVSTH				NV8
59h	CONF_MISC3	CONF_ODIOUT				CONF_ODPW				NV9
5Ah	CONF_MISC4	CONF_WDTIMER				Reserved				NV10
5Bh	CONF_MISC5	CONF_ADCSHORTTH0								NV11
5Dh	CONF_MISC18	Reserved	Reserved	CONF_P WMSLOW	CONF_LENEXT	CONF_PSEN3	CONF_PSEN2	CONF_PSEN1	CONF_PSEN0	NV13
5Eh	CONF_MISC19	Reserved	Reserved	Reserved	Reserved	CONF_MA SKPRETSD	CONF_M ASKVSUV	CONF_MA SKLOWVS	CONF_M ASKSLS	NV14
60h	CLR	Reserved	Reserved	CONF_FORCEFS	CLR_REG	CONF_FORCEERR	CLR_FS	CLR_ERR	CLR_POR	00h
61h	CONF_LOCK	Reserved	Reserved	Reserved	Reserved	CONF_CLRLOCK	CONF_CONFLOCK	CONF_IOUTLOCK	CONF_PWMLOCK	0Fh
62h	CONF_MISC9	CONF_STAYINEP	CONF_NVREADBCK	Reserved	CONF_ADCCH				00h	
63h	CONF_MISC10				CONF_SHAREPWM			CONF_READSHADOW	CONF_NVMODE	00h
64h	CONF_MISC11	CONF_MASKREF	CONF_MASKKMTPCRC	CONF_MASKOPEN	CONF_MASKSHORT	CONF_MASKSTD	CONF_NVPROGRAM	CONF_SSSTART	CONF_INVDIAGSTART	00h
65h	CONF_MISC12	CONF_NVGATE								00h
66h	ADC_IREF	ADC_IREF								X
6Eh	ECC0	ECC_WCNT								X

ADDR	Name	BIT7	BIT6	BIT5	BIT4	BIT3	BIT2	BIT1	BIT0	Default
6Fh	ECC1	ECC_ECNT								X
70h	FLAG0	FLAG_ECC	FLAG_REF	FLAG_FS	FLAG_OUT	FLAG_PRETSD	FLAG_TSD	FLAG_POR	FLAG_ERR	03h
71h	FLAG1	FLAG_CMP	FLAG_VSUUV	FLAG_EXTFS	FLAG_PROGRE ADY	FLAG_ADCLOW VS	FLAG_ADCDON E	FLAG_ODREAD Y	FLAG_NVCRRC	X
72h	FLAG2	ADC_VS								X
73h	FLAG3	ADC_OUT								00h
74h	FLAG4	FLAG_ODDIAG CH7	FLAG_ODDIAG CH6	FLAG_ODDIAG CH5	FLAG_ODDIAG CH4	FLAG_ODDIAG CH3	FLAG_ODDIAG CH2	FLAG_ODDIAG CH1	FLAG_ODDIAG CH0	00h
75h	FLAG5	Reserved	Reserved	Reserved	Reserved	FLAG_ODDIAG CH11	FLAG_ODDIAG CH10	FLAG_ODDIAG CH9	FLAG_ODDIAG CH8	00h
77h	FLAG7	CALC_NVCRRC								E7h
78h	FLAG8	CALC_CONFCRC								X
7Bh	FLAG11	FLAG_OPENCH 7	FLAG_OPENCH 6	FLAG_OPENCH 5	FLAG_OPENCH 4	FLAG_OPENCH 3	FLAG_OPENCH 2	FLAG_OPENCH 1	FLAG_OPENCH 0	00h
7Ch	FLAG12	Reserved	Reserved	Reserved	Reserved	FLAG_OPENCH 11	FLAG_OPENCH 10	FLAG_OPENCH 9	FLAG_OPENCH 8	00h
7Dh	FLAG13	FLAG_SHORTC H7	FLAG_SHORTC H6	FLAG_SHORTC H5	FLAG_SHORTC H4	FLAG_SHORTC H3	FLAG_SHORTC H2	FLAG_SHORTC H1	FLAG_SHORTC H0	00h
7Eh	FLAG14	Reserved	Reserved	Reserved	Reserved	FLAG_SHORTC H11	FLAG_SHORTC H10	FLAG_SHORTC H9	FLAG_SHORTC H8	00h
7Fh	FLAG15							FLAG_OFFOUT	FLAG_LDOOV	00h

MTP register map

Table 27. MTP register map

ADDR	Name	BIT7	BIT6	BIT5	BIT4	BIT3	BIT2	BIT1	BIT0	Default
80h	NVI0	Reserved	Reserved	NV_IOUT0						3Fh
81h	NVI1	Reserved	Reserved	NV_IOUT1						3Fh

ADDR	Name	BIT7	BIT6	BIT5	BIT4	BIT3	BIT2	BIT1	BIT0	Default
82h	NVI2	Reserved	Reserved	NV_IOUT2						3Fh
83h	NVI3	Reserved	Reserved	NV_IOUT3						3Fh
84h	NVI4	Reserved	Reserved	NV_IOUT4						3Fh
85h	NVI5	Reserved	Reserved	NV_IOUT5						3Fh
86h	NVI6	Reserved	Reserved	NV_IOUT6						3Fh
87h	NVI7	Reserved	Reserved	NV_IOUT7						3Fh
88h	NVI8	Reserved	Reserved	NV_IOUT8						3Fh
89h	NVI9	Reserved	Reserved	NV_IOUT9						3Fh
8Ah	NVI10	Reserved	Reserved	NV_IOUT10						3Fh
8Bh	NVI11	Reserved	Reserved	NV_IOUT11						3Fh
A0h	NVP0	NV_PWMOUT0								FFh
A1h	NVP1	NV_PWMOUT1								FFh
A2h	NVP2	NV_PWMOUT2								FFh
A3h	NVP3	NV_PWMOUT3								FFh
A4h	NVP4	NV_PWMOUT4								FFh
A5h	NVP5	NV_PWMOUT5								FFh
A6h	NVP6	NV_PWMOUT6								FFh
A7h	NVP7	NV_PWMOUT7								FFh
A8h	NVP8	NV_PWMOUT8								FFh
A9h	NVP9	NV_PWMOUT9								FFh
AAh	NVP10	NV_PWMOUT10								FFh
ABh	NVP11	NV_PWMOUT11								FFh
BCh	NV16	NV_ADCSHORTTH1[7:0]								00h
BDh	NV17	NV_ADCSH ORTTHCH7	NV_ADCSH ORTTHCH6	NV_ADCSH ORTTHCH5	NV_ADCSH ORTTHCH4	NV_ADCSH ORTTHCH3	NV_ADCSH ORTTHCH2	NV_ADCSH ORTTHCH1	NV_ADCSH ORTTHCH0	00h

ADDR	Name	BIT7	BIT6	BIT5	BIT4	BIT3	BIT2	BIT1	BIT0	Default
BEh	NV18	Reserved	Reserved	Reserved	Reserved	NV_ADCSH ORTTHCH11	NV_ADCSH ORTTHCH10	NV_ADCSH ORTTHCH9	NV_ADCSH ORTTHCH8	00h
BFh	NV19	Reserved	NV_PS0[1:0]		Reserved					00h
C0h	NV0	NV_FS0CH7	NV_FS0CH6	NV_FS0CH5	NV_FS0CH4	NV_FS0CH3	NV_FS0CH2	NV_FS0CH1	NV_FS0CH0	00h
C1h	NV1	Reserved	Reserved	Reserved	Reserved	NV_FS0CH11	NV_FS0CH10	NV_FS0CH9	NV_FS0CH8	00h
C2h	NV2	NV_FS1CH7	NV_FS1CH6	NV_FS1CH5	NV_FS1CH4	NV_FS1CH3	NV_FS1CH2	NV_FS1CH1	NV_FS1CH0	FFh
C3h	NV3	Reserved	Reserved	Reserved	Reserved	NV_FS1CH11	NV_FS1CH10	NV_FS1CH9	NV_FS1CH8	0Fh
C4h	NV4	NV_DIAGENC H7	NV_DIAGENC H6	NV_DIAGENC H5	NV_DIAGENC H4	NV_DIAGENC H3	NV_DIAGENC H2	NV_DIAGENC H1	NV_DIAGENC H0	FFh
C5h	NV5	Reserved	Reserved	Reserved	Reserved	NV_DIAGENC H11	NV_DIAGENC H10	NV_DIAGENC H9	NV_DIAGENC H8	0Fh
C6h	NV6	NV_AUTOSS	Reserved	NV_DEVADDR [4]	NV_EXPEN	NV_DEVADDR [3:0]				00h
C7h	NV7	NV_PWMFREQ				NV_EXTADDR	NV_OFAF	NV_REFRANGE		AFh
C8h	NV8	Reserved	NV_FLTIMEOUT			NV_ADCLOWVSTH				03h
C9h	NV9	NV_ODIOUT				NV_ODPW				00h
CAh	NV10	NV_WDTIMER				NV_INITTIMER				00h
CBh	NV11	NV_ADCSHORTTH0								00h
CCh	NV12	Reserved	Reserved	Reserved	Reserved	Reserved	Reserved	Reserved	Reserved	00h
CDh	NV13	Reserved	Reserved	NV_PWMSLOW	NV_LENEXT	NV_PSEN3	NV_PSEN2	NV_PSEN1	NV_PSEN0	00h
CEh	NV14	Reserved	Reserved	Reserved	Reserved	NV_MAS KPRETSD	NV_MASKVSUV	NV_MAS KLOWVS	NV_MASKSLS	00h
CFh	NV15	NV_CRC								E7h

14.6. Layout guide

A good PCB layout can minimize EMI, improve thermal performance, and achieves a good constant current output. For NEX13120-Q100, the following PCB layout guidelines are recommended.

- Use a continuous ground plane layer beneath the device and associated circuitry, incorporating multiple vias for enhanced grounding.
- Place the VLDO capacitor as close as possible to both the VLDO pin and the ground pin. This practice minimizes stray inductance and reduces the current loop area, helping to prevent EMI.
- Maximize the number of vias on the thermal pad to improve thermal performance.

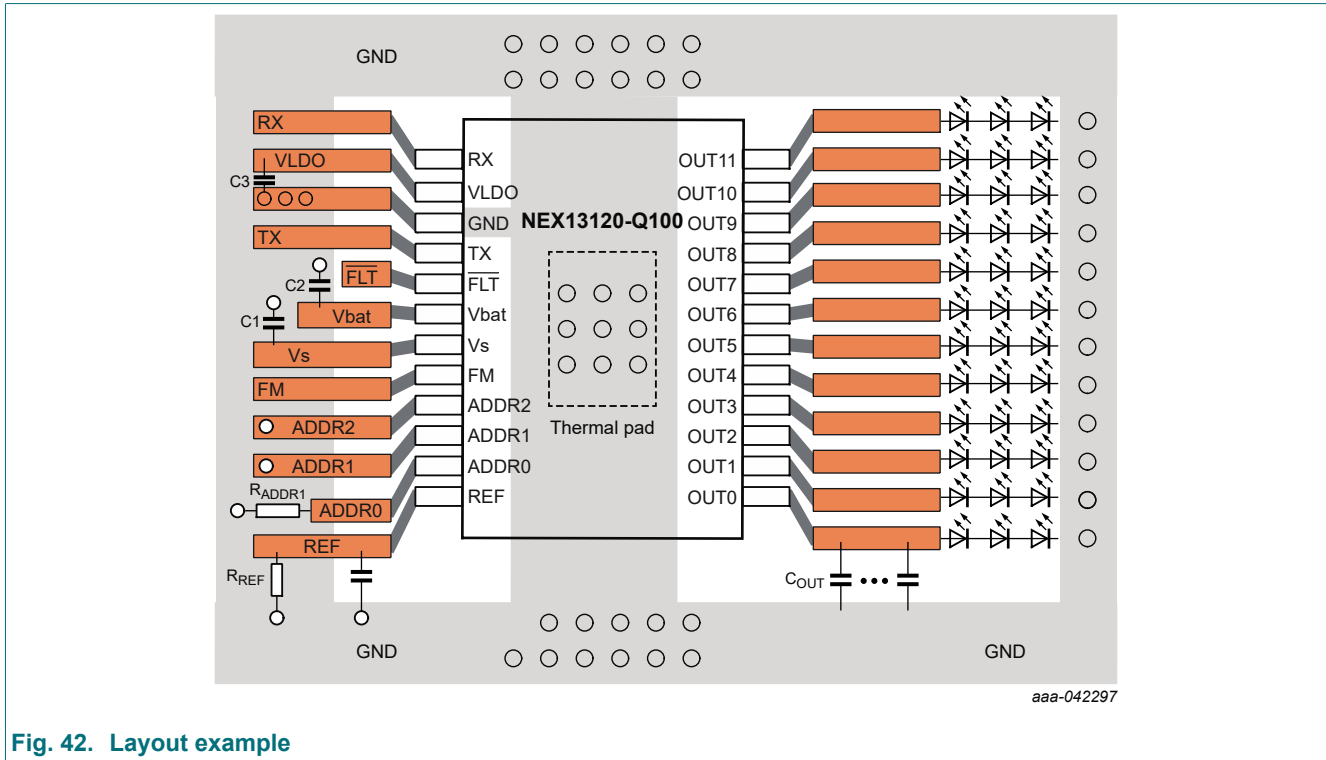

Fig. 42. Layout example

15. Package outline

HTSSOP24: 24 leads; 7.8 × 4.4 × 1.2 mm

SOT8083-1

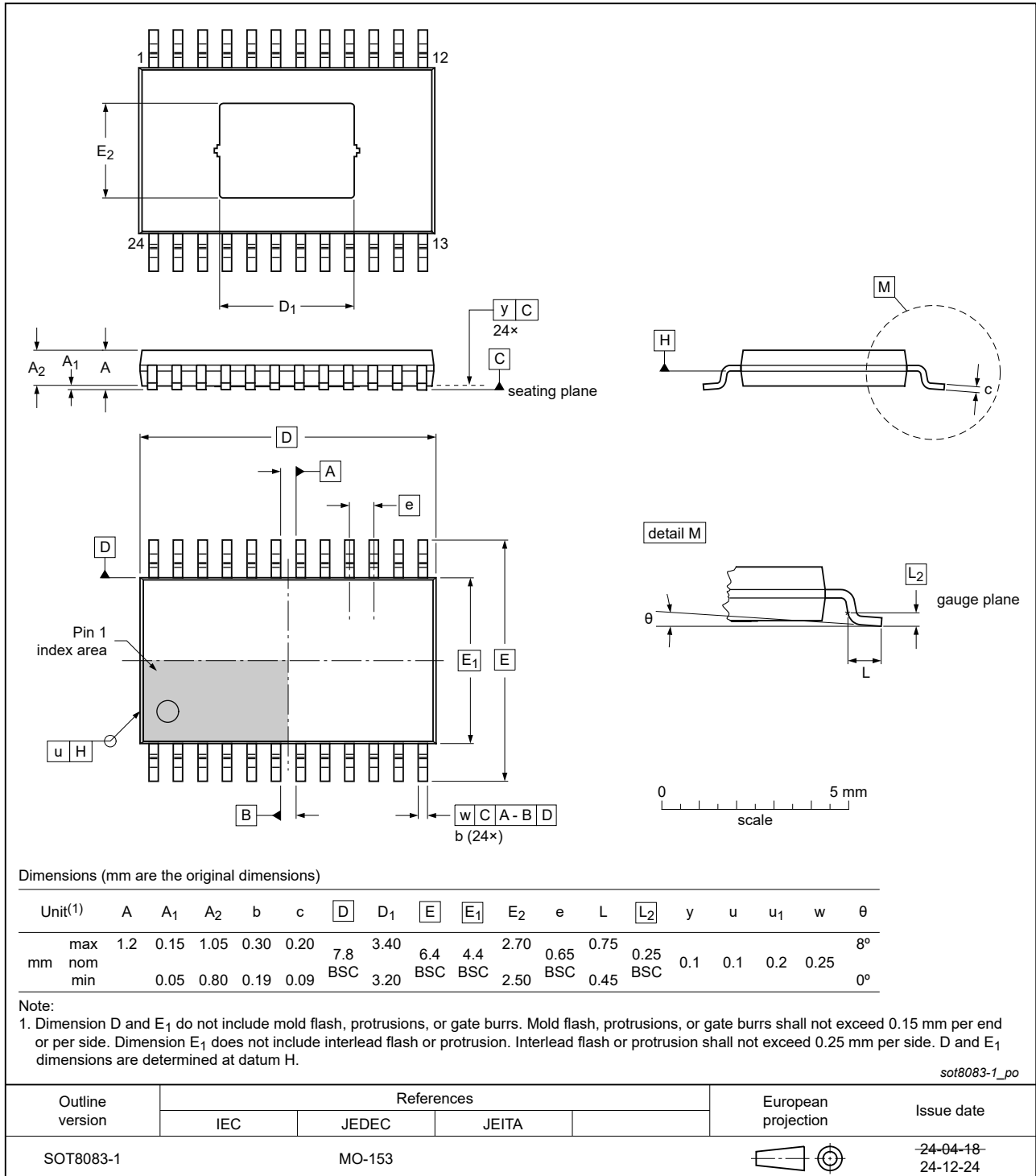

Fig. 43. Pin configuration SOT8083-1 (HTSSOP24)

16. Abbreviations

Table 28. Abbreviations

Acronym	Description
AEC	Automotive Electronics Council
BiCMOS	Bipolar Complementary Metal Oxide Semiconductor
CDM	Charged Device Model
CMOS	Complementary Metal-Oxide Semiconductor
DCO	Dynamic Controlled Output
DUT	Device Under Test
EDNMOS	Extended Drain Negative Metal-Oxide Semiconductor
ESD	ElectroStatic Discharge
ECP	Enhanced Capability Port
EPP	Enhanced Parallel Port
FET	Field-Effect Transistor
FIFO	First In First Out
HBM	Human Body Model
IEC	International Electrotechnical Commission
IEEE	Institute of Electrical and Electronics Engineers
JEDEC	Joint Electron Device Engineering Council
LSTTL	Low-power Schottky Transistor-Transistor Logic
MM	Machine Model
NMOS	N-channel Metal-Oxide Semiconductor
PCB	Printed Circuit Board
PMOS	P-channel Metal-Oxide Semiconductor
PRR	Pulse Rate Repetition
TTL	Transistor-Transistor Logic

17. Revision history

Table 29. Revision history

Document ID	Release date	Data sheet status	Change notice	Supersedes
NEX13120_Q100 v.3	20250318	Product data sheet	-	NEX13120_Q100 v.2
Modifications:	<ul style="list-style-type: none"> Minor editorial enhancements 			
NEX13120_Q100 v.2	20250121	Product data sheet	-	NEX13120_Q100 v.1
Modifications:	<ul style="list-style-type: none"> Introduction product data sheet 			
NEX13120_Q100 v.1	20241224	Short data sheet	-	-

18. Legal information

Data sheet status

Document status [1][2]	Product status [3]	Definition
Objective [short] data sheet	Development	This document contains data from the objective specification for product development.
Preliminary [short] data sheet	Qualification	This document contains data from the preliminary specification.
Product [short] data sheet	Production	This document contains the product specification.

- [1] Please consult the most recently issued document before initiating or completing a design.
- [2] The term 'short data sheet' is explained in section "Definitions".
- [3] The product status of device(s) described in this document may have changed since this document was published and may differ in case of multiple devices. The latest product status information is available on the internet at <https://www.nexperia.com>.

Definitions

Draft — The document is a draft version only. The content is still under internal review and subject to formal approval, which may result in modifications or additions. Nexperia does not give any representations or warranties as to the accuracy or completeness of information included herein and shall have no liability for the consequences of use of such information.

Short data sheet — A short data sheet is an extract from a full data sheet with the same product type number(s) and title. A short data sheet is intended for quick reference only and should not be relied upon to contain detailed and full information. For detailed and full information see the relevant full data sheet, which is available on request via the local Nexperia sales office. In case of any inconsistency or conflict with the short data sheet, the full data sheet shall prevail.

Product specification — The information and data provided in a Product data sheet shall define the specification of the product as agreed between Nexperia and its customer, unless Nexperia and customer have explicitly agreed otherwise in writing. In no event however, shall an agreement be valid in which the Nexperia product is deemed to offer functions and qualities beyond those described in the Product data sheet.

Disclaimers

Limited warranty and liability — Information in this document is believed to be accurate and reliable. However, Nexperia does not give any representations or warranties, expressed or implied, as to the accuracy or completeness of such information and shall have no liability for the consequences of use of such information. Nexperia takes no responsibility for the content in this document if provided by an information source outside of Nexperia.

In no event shall Nexperia be liable for any indirect, incidental, punitive, special or consequential damages (including - without limitation - lost profits, lost savings, business interruption, costs related to the removal or replacement of any products or rework charges) whether or not such damages are based on tort (including negligence), warranty, breach of contract or any other legal theory.

Notwithstanding any damages that customer might incur for any reason whatsoever, Nexperia's aggregate and cumulative liability towards customer for the products described herein shall be limited in accordance with the Terms and conditions of commercial sale of Nexperia.

Right to make changes — Nexperia reserves the right to make changes to information published in this document, including without limitation specifications and product descriptions, at any time and without notice. This document supersedes and replaces all information supplied prior to the publication hereof.

Suitability for use in automotive applications — This Nexperia product has been qualified for use in automotive applications. Unless otherwise agreed in writing, the product is not designed, authorized or warranted to be suitable for use in life support, life-critical or safety-critical systems or

equipment, nor in applications where failure or malfunction of an Nexperia product can reasonably be expected to result in personal injury, death or severe property or environmental damage. Nexperia and its suppliers accept no liability for inclusion and/or use of Nexperia products in such equipment or applications and therefore such inclusion and/or use is at the customer's own risk.

Quick reference data — The Quick reference data is an extract of the product data given in the Limiting values and Characteristics sections of this document, and as such is not complete, exhaustive or legally binding.

Applications — Applications that are described herein for any of these products are for illustrative purposes only. Nexperia makes no representation or warranty that such applications will be suitable for the specified use without further testing or modification.

Customers are responsible for the design and operation of their applications and products using Nexperia products, and Nexperia accepts no liability for any assistance with applications or customer product design. It is customer's sole responsibility to determine whether the Nexperia product is suitable and fit for the customer's applications and products planned, as well as for the planned application and use of customer's third party customer(s). Customers should provide appropriate design and operating safeguards to minimize the risks associated with their applications and products.

Nexperia does not accept any liability related to any default, damage, costs or problem which is based on any weakness or default in the customer's applications or products, or the application or use by customer's third party customer(s). Customer is responsible for doing all necessary testing for the customer's applications and products using Nexperia products in order to avoid a default of the applications and the products or of the application or use by customer's third party customer(s). Nexperia does not accept any liability in this respect.

Limiting values — Stress above one or more limiting values (as defined in the Absolute Maximum Ratings System of IEC 60134) will cause permanent damage to the device. Limiting values are stress ratings only and (proper) operation of the device at these or any other conditions above those given in the Recommended operating conditions section (if present) or the Characteristics sections of this document is not warranted. Constant or repeated exposure to limiting values will permanently and irreversibly affect the quality and reliability of the device.

Terms and conditions of commercial sale — Nexperia products are sold subject to the general terms and conditions of commercial sale, as published at <http://www.nexperia.com/profile/terms>, unless otherwise agreed in a valid written individual agreement. In case an individual agreement is concluded only the terms and conditions of the respective agreement shall apply. Nexperia hereby expressly objects to applying the customer's general terms and conditions with regard to the purchase of Nexperia products by customer.

No offer to sell or license — Nothing in this document may be interpreted or construed as an offer to sell products that is open for acceptance or the grant, conveyance or implication of any license under any copyrights, patents or other industrial or intellectual property rights.

Export control — This document as well as the item(s) described herein may be subject to export control regulations. Export might require a prior authorization from competent authorities.

Translations — A non-English (translated) version of a document is for reference only. The English version shall prevail in case of any discrepancy between the translated and English versions.

Trademarks

Notice: All referenced brands, product names, service names and trademarks are the property of their respective owners.

Contents

1. General description	1
2. Features and benefits	1
3. Applications	1
4. Ordering information	2
5. Device comparison	2
6. Marking	2
7. Application block diagram	3
8. Pinning information	4
8.1. Pinning.....	4
8.2. Pin description.....	4
9. Limiting values	5
10. Recommended operating conditions	5
11. Thermal information	6
12. Electrical characteristics	6
13. Typical characteristics	9
14. Detailed description	14
14.1. Overview.....	14
14.2. Function block diagram.....	15
14.3. Feature description.....	15
14.3.1. Device bias and power.....	15
14.3.2. Constant current output.....	16
14.3.3. PWM dimming.....	18
14.3.4. Fail-Safe state operation.....	21
14.3.5. 8 bit ADC.....	21
14.3.6. Diagnostic and protection in NORMAL state.....	22
14.3.7. Diagnostic and protection in FAIL-SAFE state.....	32
14.3.8. OFAF setup in FAIL-SAFE state.....	37
14.3.9. $\overline{\text{FLT}}$ Output.....	37
14.4. Device functional modes.....	38
14.4.1. POR state.....	38
14.4.2. INITIALIZATION state.....	39
14.4.3. NORMAL state.....	39
14.4.4. FAIL-SAFE state.....	39
14.4.5. PROGRAM state.....	39
14.5. Normal register map and MTP register map.....	44
14.6. Layout guide.....	50
15. Package outline	51
16. Abbreviations	52
17. Revision history	52
18. Legal information	53

© Nexperia B.V. 2025. All rights reserved

For more information, please visit: <http://www.nexperia.com>
 For sales office addresses, please send an email to: salesaddresses@nexperia.com
 Date of release: 18 March 2025