



NEX30606

1.8 V to 5.0 V, 600 mA, 220 nA ultra-low quiescent current, step-down converter

Rev. 1 — 20 November 2024

Product data sheet

1. General description

The NEX30606 is a high-efficiency step-down converter with ultra-low operating quiescent current of typically 220 nA.

The device uses COT control (Constant On Time) to achieve low power consumption mode and fast transient, operates with a switching frequency of 1.5 MHz. At light load conditions, it seamlessly enters Power Save Mode to reduce switching cycles and maintain high efficiency.

Output voltage can be configured by VSET pin. For 1.8 V output, connects the VSET pin to GND. For other output voltages, connects resistor to VSET pin following values in [Table 5](#). Sixteen internally set voltages can be selected.

The NEX30606 provides an output current up to 600 mA. With input voltage up to 5.0 V, the devices supports multiple sources such as 2S to 3S Alkaline, 1S Li-MnO₂, 1S Li-ion/Li-SOCL₂.

The NEX30606 device series comes in a tiny 6-pin WLCSP package with 0.35-mm pitch.

2. Features and benefits

- 220 nA operating quiescent current
- Input voltage range V_{VIN} from 1.8 V to 5.0 V
- Output current up to 600 mA
- 16 selectable fixed output voltages
- 2% output voltage accuracy
- Output discharge
- Constant on time control
- >90% efficiency at $I_{OUT} = 1$ mA ($V_{VIN} = 3.6$ V to $V_{OUT} = 1.8$ V)
- >92.8% efficiency at $I_{OUT} = 300$ mA ($V_{VIN} = 3.6$ V to $V_{OUT} = 1.8$ V)
- Pseudo-fixed 1.5 MHz switching frequency
- Enable pin
- WLCSP6 (SOT8055-1) package option
- ESD protection:
 - HBM: ANSI/ESDA/JEDEC JS-001 class 2 exceeds 2000 V
 - CDM: ANSI/ESDA/JEDEC JS-002 class C2a exceeds 500 V
- Specified from $T_j = -40$ °C to +85 °C and -40 °C to +125 °C

3. Applications

- Wearable electronics
- Smart meters
- Asset tracking device
- Medical sensor patches and monitor
- Industrial IOT/Narrowband (NB)-IOT
- 3 x AA battery powered applications

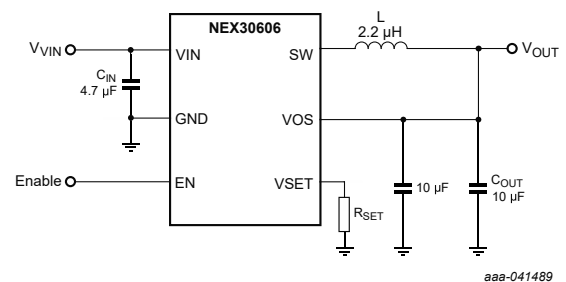

Fig. 1. Typical application

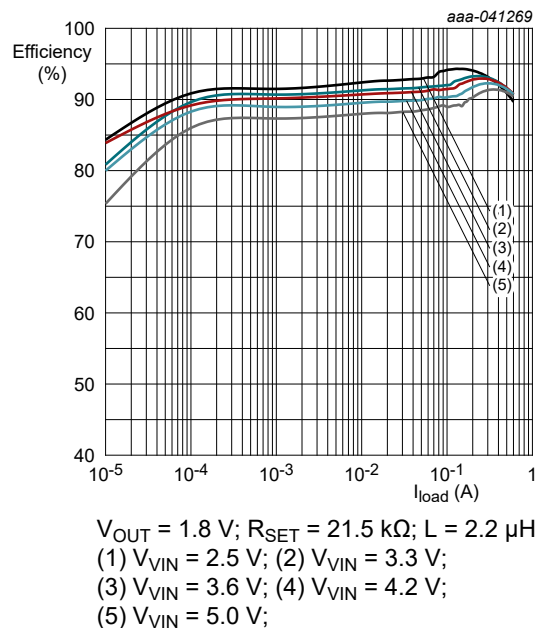

Fig. 2. Efficiency versus load current

4. Ordering information

Table 1. Ordering information

Type number	Package			
	Temperature range	Name	Description	Version
NEX30606UA	-40 °C to +125 °C	WLCSP6	Wafer level chip-size package; 6 bumps (3 x 2)	SOT8055-1

5. Marking

Table 2. Marking codes

Type number	Marking code[1]
NEX30606UA	A

[1] The pin 1 indicator is located on the lower left corner of the device, below the marking code.

6. Functional diagram

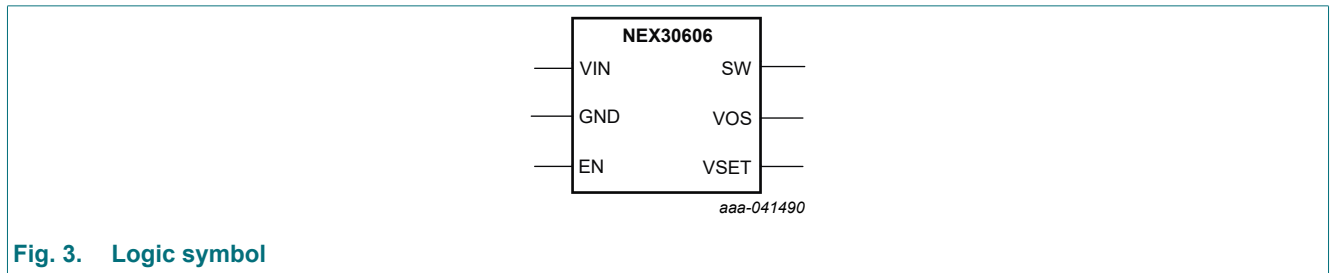

7. Pinning information

7.1. Pinning

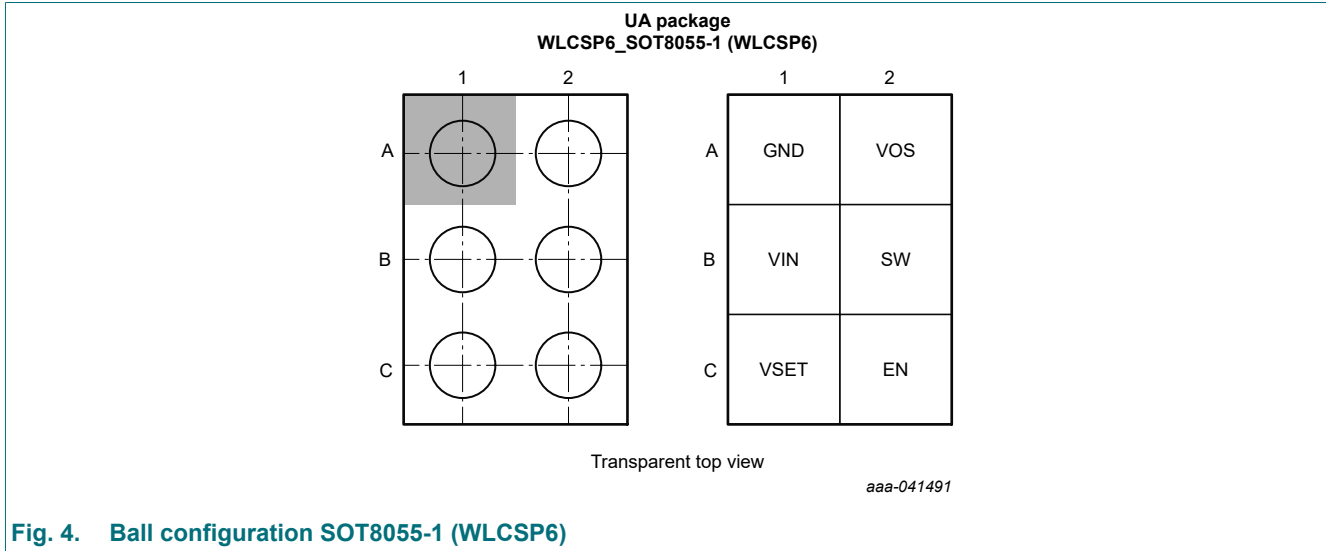

7.2. Pin description

Table 3. Pin description

Symbol	Ball	I/O	Description
	WLCSP6		
GND	A1	PWR	GND supply pin. Connect this pin close to the GND terminal of the input and output capacitors.
VIN	B1	PWR	VIN power supply pin. Connect the input capacitor close to this pin for best noise and voltage spike suppression. A 4.7 μ F ceramic capacitor is required.
VSET	C1	IN	Connecting a resistor to GND sets the output voltage when the converter is enabled before soft-start; When this pin is connected to GND, set default to 1.8 V. Once the device has started up, the VSET function is disabled.
EN	C2	IN	Enable pin. A high level enables the device and a low level turns the device off. The pin features an internal pull-down resistor, which is disabled once the device has started up and the output voltage is regulated. The pull-down resistor is activated again, once a low level has been detected.
SW	B2	PWR	The switch pin is connected to the internal MOSFET switches. Connect the inductor to this terminal.
VOS	A2	IN	Output voltage sense pin for the internal feedback divider network and regulation loop. When the converter is disabled, this pin discharges VOUT by an internal MOSFET. Connect this pin directly to the output capacitor with a short trace.

8. Device comparison

Table 4. Device Comparison

Type number	Fix Voltage	I _{OUT} [A]	Mode	F _{SW} [MHz]
NEX30606UA	1.8 V (16 selectable)	0.6	PFM/PWM	1.5

9. NEX30606 output voltage setting

Table 5. NEX30606 output voltage setting

VSET	Output voltage setting V _{OUT} (V)	R _{SET} (kΩ) resistor value, E96 resistor, 1% accuracy
0	1.8 V	Connected to GND (no resistor needed)
1	0.7 V	3.32 kΩ
2	0.8 V	5.11 kΩ
3	0.9 V	7.50 kΩ
4	1.2 V	10.2 kΩ
5	1.3 V	13.3 kΩ
6	1.5 V	16.9 kΩ
7	1.8 V	21.5 kΩ
8	1.85 V	26.7 kΩ
9	1.9 V	52.3 kΩ
10	2.7 V	82.5 kΩ
11	2.8 V	118 kΩ
12	2.95 V	162 kΩ
13	3.0 V	210 kΩ
14	3.3 V	267 kΩ
15	0.7 V	340 kΩ or larger

10. Limiting values

Table 6. Limiting values

In accordance with the Absolute Maximum Rating System (IEC 60134). Voltages are referenced to GND (ground = 0 V).

Symbol	Parameter	Conditions	Min	Max	Unit
V _I	input voltage	pin VIN	-0.3	5.5	V
		pin SW (DC)	-0.3	V _{VIN} +0.3	V
		pin SW (AC), less than 10 ns	-2.0	6.5	V
		pin EN	-0.3	5.5	V
		pin VSET	-0.3	V _{VIN} +0.3	V
		pin VOS	-0.3	3.7	V
T _j	junction temperature		-40	+150	°C
T _{stg}	storage temperature		-65	+150	°C
ESD ratings					
V _{ESD}	electrostatic discharge	HBM: ANSI/ESDA/JEDEC JS-001 Class 2	-	±2000	V
		CDM: ANSI/ESDA/JEDEC JS-002 Class C2a	-	±500	V

11. Recommended operating conditions

Table 7. Recommended operating conditions

Symbol	Parameter	Conditions	Min	Typ	Max	Unit
V _{VIN}	supply voltage on pin VIN	startup voltage V _{VIN} = 2.0 V - 5.0 V	1.8	-	5.0	V
I _{OUT}	output current		-	-	0.6	A
L	effective Inductance		-	2.2		μH
C _{OUT}	effective output capacitance		-	20	40	μF
C _{IN}	effective input capacitance		-	4.7	-	μF
C _{VSET}	external parasitic capacitance at VSET pin		-	-	30	pF
R _{SET}	external resistance range		3.32	21.5	340	kΩ
T _J	junction temperature		-40	-	125	°C

12. Thermal Information

Table 8. Thermal information

Symbol	Parameter	Package	Unit
R _{θJA}	junction to ambient thermal resistance	147	°C/W
Φ _{JB}	junction to board char parameter	28.5	°C/W

13. Electrical characteristics

Table 9. Electrical characteristics

At recommended operating conditions; V_{VIN} = 3.6 V, T_J = -40 °C to +125 °C. Typical values measured at T_J = 25 °C (unless otherwise noted), voltages are referenced to GND (ground = 0 V).

Symbol	Parameter	Conditions	T _J = -40 °C to +125 °C			Unit
			Min	Typ[1]	Max	
Supply						
I _{q(nl)}	no load operating input current	EN = VIN, I _{OUT} = 0 μA, V _{OUT} = 1.8 V, device switching, T _J = -40 °C to +85 °C	-	220	-	nA
I _{q(VIN)}	operating quiescent current into pin VIN	EN = VIN, I _{OUT} = 0 μA, V _{OUT} = 1.8 V, device non-switching, T _J = -40 °C to +85 °C	-	220	450	nA
I _{q(VOS)}	operating quiescent current into pin VOS	EN = VIN, I _{OUT} = 0 μA, V _{OUT} = 1.8 V, device non-switching	-	12	24	nA
I _{SD}	shutdown current	EN = GND, shutdown current into VIN, VSET = GND, T _J = -40 °C to 85 °C	-	7	150	nA
V _{TH_UVLO+}	undervoltage lockout threshold	rising V _{VIN}	-	1.82	2.2	V
		falling V _{VIN}	-	1.6	1.9	V
Hysteresis		hysteresis	-	215	-	mV
Input EN, VSEL						
V _{IH}	high level input voltage		1.1	-	-	V
V _{IL}	low level input voltage		-	-	0.4	V
I _{EN}	input bias current	EN = High	-	1	10	nA
R _{PD}	internal pull-down resistance	EN = Low	-	500	-	kΩ
Power switches						

1.8 V to 5.0 V, 600 mA, 220 nA ultra-low quiescent current, step-down converter

Symbol	Parameter	Conditions	T _j = -40 °C to +125 °C			Unit
			Min	Typ[1]	Max	
I _{LKG(SW)}	leakage current into SW pin	V _{SW} = 1.8 V, T _j = -40 °C to +85 °C	-	210	300	nA
R _{DS(ON)}	high side MOSFET on-resistance	V _{VIN} = 3.6 V, I _{OUT} = 200 mA	-	100	142	mΩ
	low side MOSFET on-resistance	V _{VIN} = 3.6 V, I _{OUT} = 200 mA	-	80	115	mΩ
I _{LIMH}	high side MOSFET switch current limit		0.8	1.1	1.4	A
I _{LIML}	low side MOSFET switch current limit		0.7	1.0	1.3	A
Output voltage discharge						
I _{dch(VOS)}	output discharge current	sink current into VOS pin, EN = GND, V _{OUT} = 1.8 V, T _j = -40 °C to 85 °C	-	20	28	mA
Thermal protection						
T _{SD}	thermal shutdown temperature	rising junction temperature [2]	-	160	-	°C
	thermal shutdown hysteresis	[2]	-	18	-	°C
Output						
V _{OUT}	output voltage accuracy	PWM mode, I _{OUT} = 0 mA, V _{OUT} = 0.7 to 1.9 V, T _j = 25 °C	-2	0	2	%
		PWM mode, I _{OUT} = 0 mA, V _{OUT(PWM)} = 2.7 to 3.3 V, T _j = 25 °C	-2.5	0	2.5	%
V _{OUT}	output voltage range		0.7	-	3.3	V
UVP	output UVP detection voltage		-	0.5×V _{OUT}	-	V
f _{SW}	switching frequency	V _{VIN} = 3.6 V, V _{OUT} = 1.8 V, PWM mode	-	1.5	-	MHz
t _{startup_delay}	regulator start up delay time	from EN = LOW to HIGH until the device starts switching	-	1	1.4	ms
t _{SS}	soft start time	from V _{OUT} 0 V to 0.95% of V _{OUT} nominal	-	600	1200	μs
T _{ON(min)}	minimum ON time	V _{VIN} = 5.0 V V _{OUT} = 0.7 V, I _{OUT} = 0 A [2]	-	93	-	ns
T _{OFF(min)}	minimum OFF time	V _{VIN} = 3.5 V V _{OUT} = 3.3 V, I _{OUT} = 600 mA [2]	-	60	-	ns

[1] All typical values are measured at T_j = 25 °C (unless otherwise noted)

[2] Guaranteed by design

14. Detailed description

14.1. Overview

The NEX30606 is a synchronous step-down converter with ultra-low quiescent current consumption. Using COT (Constant On Time) topology, the device extends the high efficiency operation area down to micro amperes of load current during Power-SaveMode Operation. Depending on the output voltage, the device consumes quiescent current from both the input and output to reduce the overall input current consumption to 220 nA typical.

COT control monitors the output voltage using a comparator if output voltage falls below the target voltage. High side Power FET will turn on rapidly without some delay. Characteristics of COT control are excellent DC load regulation and transient response, low output ripple voltage.

The device operates with a nominal switching frequency. The internally compensated regulation network achieves fast and stable operation with small external components and low ESR capacitors.

In Power-Save Mode, the switching frequency varies linearly with the load current. The NEX30606 offers both, excellent DC voltage and superior load transient regulation, combined with low output voltage ripple thereby minimizing interferences with radio frequency circuits.

14.2. Function block diagram

The NEX30606 function block diagram is shown in [Fig. 5](#).

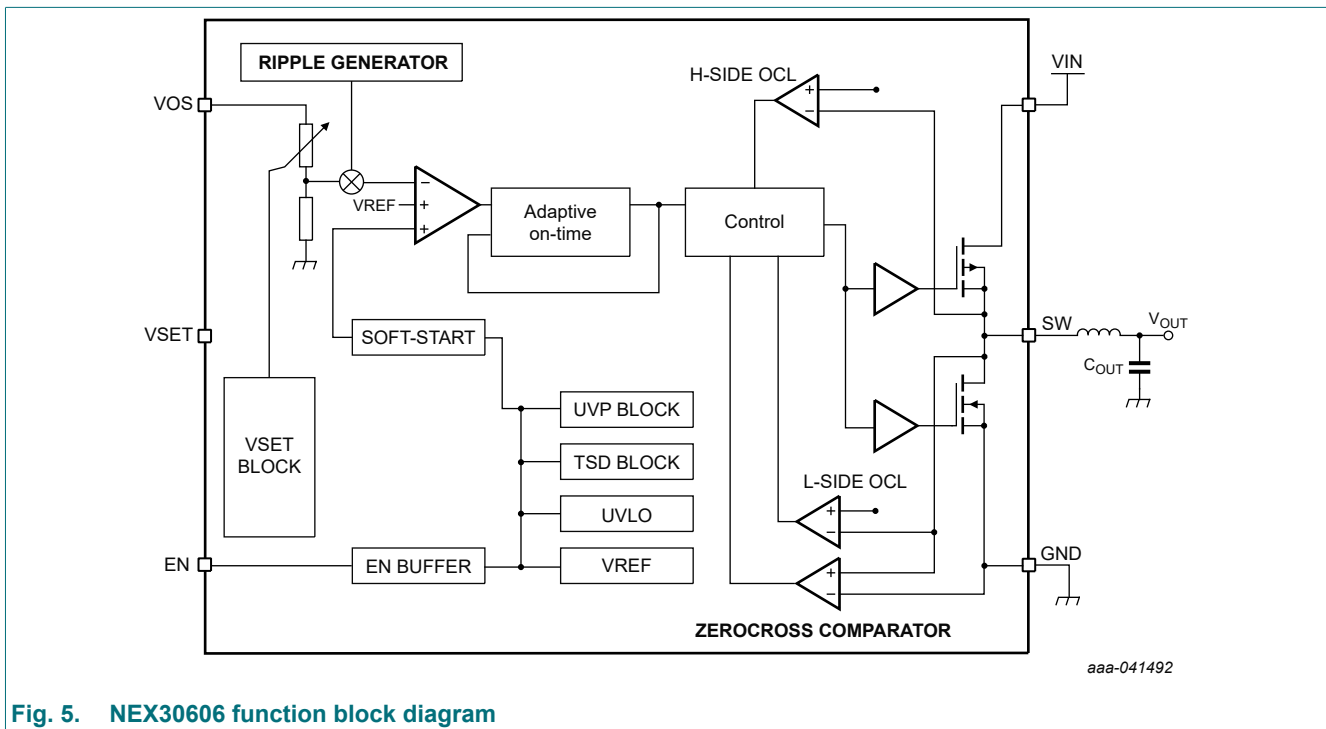

Fig. 5. NEX30606 function block diagram

14.3. Feature description

14.3.1. COT control and PWM operation

The main control loop of NEX30606 is adaptive on time Pulse Width Modulation (PWM) controller that supports Constant On Time mode control (COT). This unique COT mode control combines adaptive on-time control with an internal compensation circuit for pseudo- fixed frequency and low external component count configuration with both low ESR and ceramic output capacitor. It's stable even with virtually no ripple at the output.

At the beginning of each cycle, the high-side MOSFET is turned on. This MOSFET is turned off after internal one-shot timer expires. This on time duration is set proportional to the converter output voltage V_{OUT} , and inversely proportional to the input voltage V_O , to maintain a pseudo-fixed frequency over the input voltage range. The one-shot timer is reset and the high-side MOSFET is turned on again when the feedback voltage falls below the reference voltage.

14.3.1.1. Output voltage selection (VSET)

The output voltage is set with a single external resistor connected between the VSET pin and GND. Once the device has been enabled and the control logic as well as the reference system are powered up, an R2D (resistor to digital) conversion is started to detect the value of the external R_{SET} resistor within the regulator startup delay time $t_{startup_delay}$. An internal current source applies current through the external resistor and an internal ADC reads back the resulting voltage level. Depending on the level, an internal feedback divider network is selected to set the correct output voltage. Once this R2D conversion is finished, the current source is turned off to avoid current flow through the external resistor. Therefore, the output voltage is set only once. Ensure that there is no additional current path or capacitance to GND. The R2D converter is designed to operate with resistor values out of the E96 table and requires 1% resistor value accuracy. [Table 5](#) shows the allowed R_{SET} values.

14.3.1.2. Power save mode

Power save mode usually designed to maintain high light load efficiency. The converter operates in PWM mode at moderate to heavy loads and in PFM mode during light loads.

As the output current decreases from heavy load condition, the inductor current is also reduced and eventually comes to point that its rippled valley touches zero level, which is boundary between continuous conduction and discontinuous conduction modes. The rectify MOSFET is turned off when the zero inductor current is detected. As the load current further decreases, the converter runs into discontinuous conduction mode. The on-time is kept almost the same as it was in the continuous conduction mode so that it takes longer time to discharge the output capacitor with smaller load current to the level of the reference voltage. This makes the switching frequency lower, proportional to the load current, and keeps the light load efficiency high.

14.3.2. Ultra low power (ULP) mode

The NEX30606 device works in PFM mode during light load condition, and two comparators are used in the silicon to monitor V_{OUT} . One is main comparator and the other is ULP comparator.

The transition from normal mode to ULP mode is judged pulse by pulse. When the main compactor or the ULP comparator detects the decrease on V_{OUT} , the SW node switches for one pulse, then becomes High impedance (high-side MOSFET and low-side MOSFET are both off) after inductor current go zero.

If the high impedance state starts after zero cross comparator detects inductor current zero, the device transits from normal mode to ULP mode.

In ULP mode, the main comparator and most of the internal circuits are shutdown to achieve lowest operating quiescent current. The duration of the ULP period depends on the load current. During the ULP mode, the current consumption is reduced to typically 220 nA.

When ULP comparator detects the decrease in V_{OUT} , the main comparator and other internal circuits are enabled, the device transition from ULP mode to normal mode.

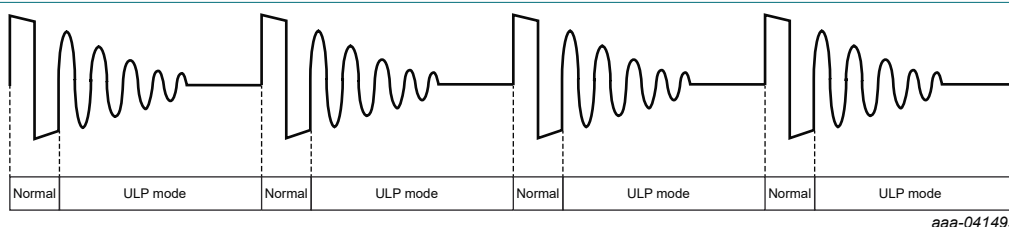

Fig. 6. ULP mode transition

14.3.3. Smart enable and shutdown (EN)

To avoid a floating input, an internal 500 k Ω resistor pulls the EN pin to GND. This prevents an uncontrolled start-up of the device in case the EN pin cannot be driven low safely. The device is in shutdown mode when the EN input is logic low.

1.8 V to 5.0 V, 600 mA, 220 nA ultra-low quiescent current, step-down converter

The NEX30606 device turns on with a logic High EN signal. An internal control circuit disconnects the EN pin pull-down resistor once the device has finished soft start and the output voltage is in regulation. With the EN pin set low, the device enters shutdown mode and the pull-down resistor is activated again.

14.3.4. Soft start

The NEX30606 device has an internal soft-start to minimize input voltage drop during start-up. This allows the operation from high impedance battery cells.

Once the device has been enabled with EN high, it initializes and powers up its internal circuits. This occurs during the regulator start-up delay time $t_{\text{startup_delay}}$. Once $t_{\text{startup_delay}}$ expires, the internal soft start circuitry ramps up the output voltage within the soft-start time t_{SS} .

The device operates with a nominal switch current limit throughout the entire soft-start phase.

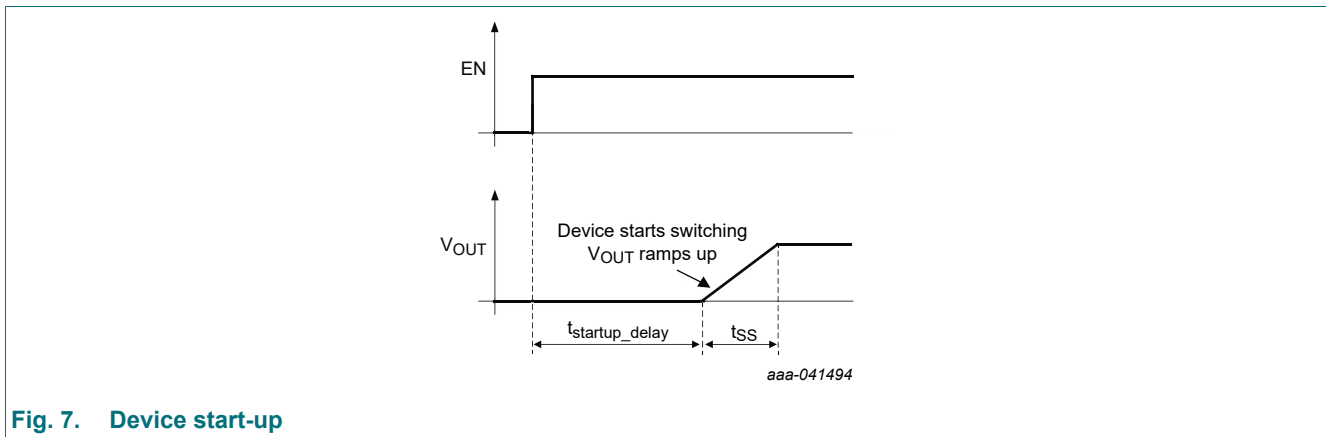

Fig. 7. Device start-up

14.3.5. Undervoltage lockout (UVLO)

To avoid mis-operation of the device at low input voltages, an undervoltage lockout (UVLO) comparator monitors the supply voltage. The UVLO comparator shuts down the device at an input below the threshold $V_{\text{TH_UVLO-}}$ with falling V_{VIN} . The device starts at an input voltage higher than the threshold $V_{\text{TH_UVLO+}}$ with rising V_{VIN} .

When the device resumes operation from an undervoltage lockout condition, it behaves like being enabled. This means the internal control logic is powered up, the external R_{SET} resistor is read out and a soft-start sequence is initiated.

14.3.6. Overcurrent protection function

The NEX30606 device integrates a current limit on the high-side as well as on the low-side MOSFETs to protect the device against overload or short circuit conditions. The current in the switches is monitored cycle-by-cycle. If the high-side MOSFET current limit (I_{LIMH}) trips, the high-side MOSFET is turned off and the low-side MOSFET is turned on to ramp the inductor current down. Once the inductor current decreases below the low-side current limit (I_{LIML}), the low-side MOSFET turns off and the high-side MOSFET turns on again.

During soft start, the current limit is the nominal value I_{LIMH} .

In forced PWM mode, a negative current limit (I_{LIMN}) is enabled to prevent excessive current flowing backwards to the input. When the inductor current reaches I_{LIMN} , the low-side MOSFET turns off and the high-side MOSFET turns on.

14.3.7. Automatic recovery type short-circuit protection function (Hiccup mode)

The NEX30606 device has a built-in automatic recovery type short-circuit protection function for hiccup control.

Hiccup control is a method for periodically carrying out automatic recovery when the IC detects overcurrent and stops the switching operation.

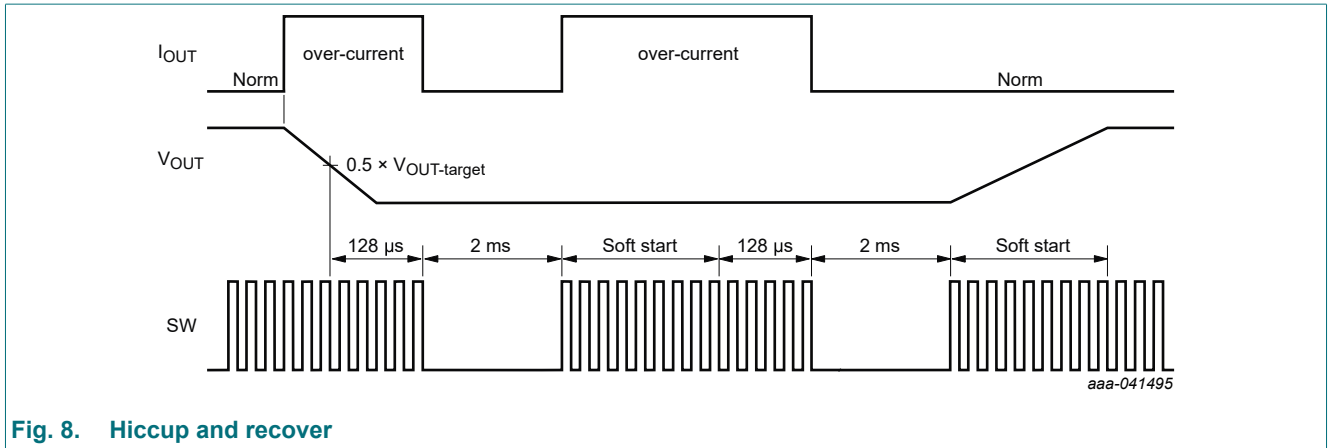

Fig. 8. Hiccup and recover

If an output overload condition which is detected by overcurrent limit function or short circuit, also Under Voltage Protection circuit (UVP circuit) detects a drop in the output voltage and last for 128 μ s, the device shuts down and enter hiccup mode. The device stop switching operation for 2 ms, and restarts again later. The Hiccup mode helps to reduce the power dissipation of the device under the overload condition.

The UVP function is disabled during soft-start time, and has a 120 μ s blank time after soft-start finish.

14.3.8. Output voltage discharge

The purpose of the output discharge function is to ensure a defined down-ramp of the output voltage when the device is disabled and to keep the output voltage close to 0 V. The output discharge feature is only active once the device has been enabled at least once since the supply voltage was applied. The output discharge function is not active if the device is disabled and the supply voltage is applied the first time.

The internal discharge resistor is connected to the VOS pin. The discharge function is enabled as soon as the device is disabled. The minimum supply required to keep the discharge function active is $V_{VIN} > V_{TH_UVLO}$.

14.3.9. Thermal shutdown

The junction temperature (T_j) of the device is monitored by an internal temperature sensor. The T_j exceeds the thermal shutdown temperature T_{SD} of 160 $^{\circ}$ C, the device enters thermal shutdown. Both the high side and low side power FETs are turned off. When T_j decreases below the hysteresis amount of typically 18 $^{\circ}$ C, the converter resumes operation, beginning with a soft start to the originally set V_{OUT} . The thermal shutdown is not active in power (ULP) mode.

15. Application implementation

15.1. Overview

The NEX30606 is a synchronous step-down converter with ultra-low quiescent current consumption. Using COT (Constant On Time) topology, the device extends the high efficiency operation area down to micro amperes of load current during Power-SaveMode Operation. Depending on the output voltage, the device consumes quiescent current from both the input and output to reduce the overall input current consumption to 220 nA typical.

COT control monitors the output voltage using a comparator if output voltage falls below the target voltage. High side Power FET will turn on rapidly without some delay. Characteristics of COT control are excellent DC load regulation and transient response, low output ripple voltage.

The device operates with a nominal switching frequency. The internally compensated regulation network achieves fast and stable operation with small external components and low ESR capacitors.

In Power-Save Mode, the switching frequency varies linearly with the load current. The NEX30606 offers both, excellent DC voltage and superior load transient regulation, combined with low output voltage ripple thereby minimizing interferences with radio frequency circuits.

15.2. Typical application

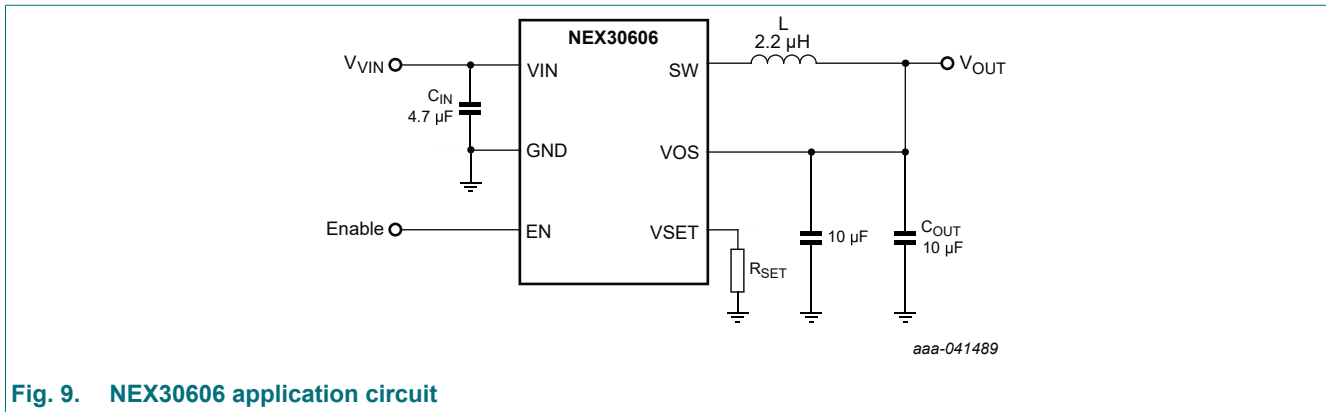

Fig. 9. NEX30606 application circuit

15.2.1. Design requirements

A typical application is the lithium battery-powered case for smart watches, usually requiring a 1.8 V output voltage to power Soc. The design parameters are listed in [Table 10](#).

Table 10. Components for NEX30606 application circuit.

Reference	Part number	Value	Size	Manufacturer
IC	NEX30606UA	1.8 V/600 mA	1.09 mm x 0.74 mm	Nexperia
C _{IN}	GRM155R60J475ME87	4.7 µF	0402	Murata/TDK
C _{OUT}	GRM155R60J106ME18	10 µF (2x)	0402	Murata/TDK
L	HTQH20120H-2R2MSR/DFE201610E-2R2M	2.2 µH	0805	Cyntec/ Murata

15.2.2. Inductor selection

The inductor value affects the peak-to-peak ripple current, the PWM to PFM transition point, the output voltage ripple and the efficiency. The selected inductor has to be rated its DC resistance and saturation current. The inductor ripple current (ΔI_L) decreases with higher inductance and increases with higher V_{VIN} and can be estimated according to equation (1) below.

Equation (2) calculates the maximum inductor current under static load conditions. The saturation current of inductor should be rated higher than the maximum inductor current, as calculated with Equation 2. This is recommended because during a heavy load transient the inductor current rises above the calculated value. A more conservative way is to select the inductor saturation current according to the high side MOSFET switch current limit.

$$\Delta I_L = V_{OUT} \times \frac{1 - \frac{V_{OUT}}{V_{VIN}}}{L \times f} \quad (1)$$

$$I_{Lmax} = I_{OUTmax} \times \frac{\Delta I_L}{2} \quad (2)$$

Where:

f = Switching frequency

L = Inductor value

ΔI_L = Peak to Peak inductor ripple current

I_{Lmax} maximum inductor current

15.2.3. Output capacitor selection

The constant on time control scheme of the NEX30606 allows the use of tiny ceramic capacitors. Ceramic capacitors with low ESR values have the lowest output voltage ripple and are recommended. The output capacitor requires either an X7R or

1.8 V to 5.0 V, 600 mA, 220 nA ultra-low quiescent current, step-down converter

X5R dielectric. At light load currents, the converter operates in Power Save mode and the output voltage ripple is dependent on the output capacitor value. A larger output capacitors can be used reducing the output voltage ripple.

The inductor and output capacitor together provides a low-pass filter. To simplify the process, [Table 11](#) below outlines the possible inductor and capacitor.

Table 11. Recommended output capacitor

Reference	Nominal inductor value	Nominal output capacitor value	
		2 x 10 μF	22 μF
NEX30606	2.2 μH	Yes	Yes

15.2.4. Input capacitor selection

Due to Buck converter has a pulsating input current, a low ESR ceramic input capacitor is required for best input voltage filtering to minimize input voltage spikes. For most applications a 4.7 μF input capacitor is sufficient. When operating from a high impedance source, like a coin cell, a larger input buffer capacitor >10 μF is recommended to avoid voltage drop during start-up and load transients. The input capacitor can be increased without any limit for better input voltage filtering. The leakage current of the input capacitor adds to the overall current consumption.

Table 12. Recommended input capacitor

Reference	Part number	Capacitance	Size	Manufacturer
C _{IN}	GRM155R60J475ME87	4.7 μF	0402	Murata
C _{IN}	GRM155R60J106ME18	10 μF	0402	Murata

16. Layout

16.1. Layout examples

[Fig. 10](#) shows a layout example of NEX30606 (WLCSP6) device.

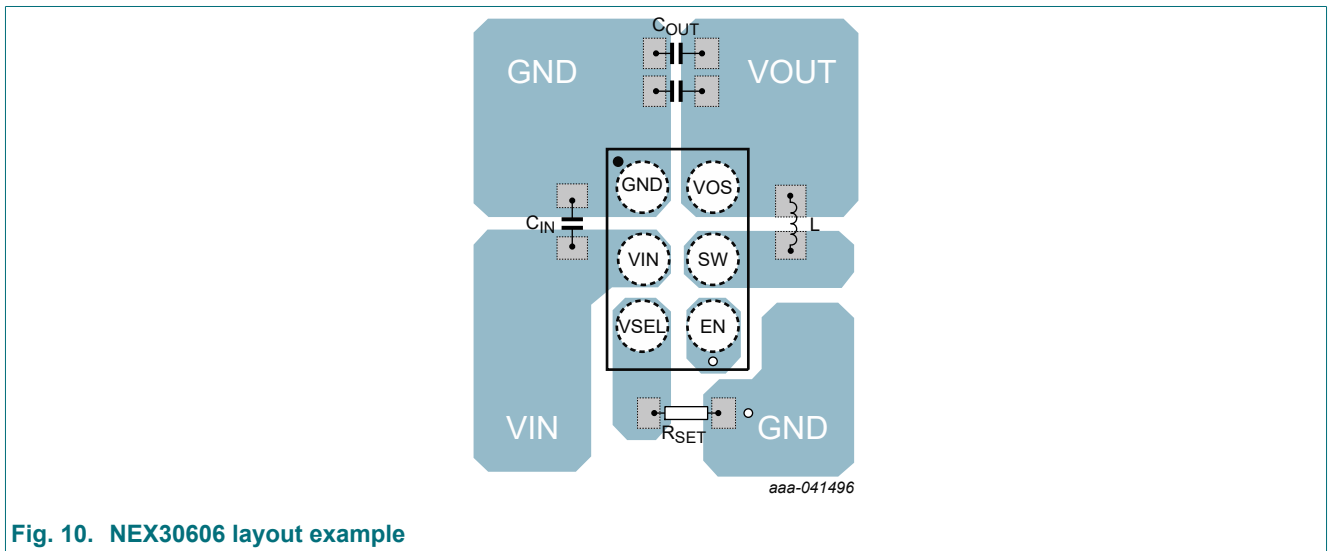
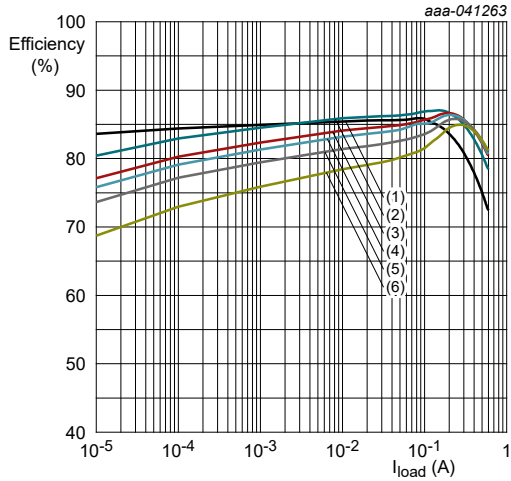

Fig. 10. NEX30606 layout example

17. Application graphs

17.1. Typical operating characteristics



$V_{OUT} = 0.7\text{ V}$; $R_{SET} = 3.32\text{ k}\Omega$; $L = 2.2\text{ }\mu\text{H}$
 (1) $V_{VIN} = 1.8\text{ V}$; (2) $V_{VIN} = 2.5\text{ V}$; (3) $V_{VIN} = 3.3\text{ V}$;
 (4) $V_{VIN} = 3.6\text{ V}$; (5) $V_{VIN} = 4.2\text{ V}$; (6) $V_{VIN} = 5.0\text{ V}$

Fig. 11. Efficiency versus load current

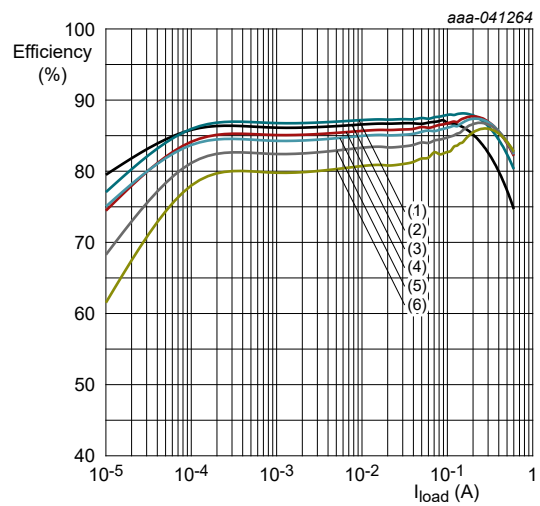

$V_{OUT} = 0.8\text{ V}$; $R_{SET} = 5.11\text{ k}\Omega$; $L = 2.2\text{ }\mu\text{H}$
 (1) $V_{VIN} = 1.8\text{ V}$; (2) $V_{VIN} = 2.5\text{ V}$; (3) $V_{VIN} = 3.3\text{ V}$;
 (4) $V_{VIN} = 3.6\text{ V}$; (5) $V_{VIN} = 4.2\text{ V}$; (6) $V_{VIN} = 5.0\text{ V}$

Fig. 12. Efficiency versus load current

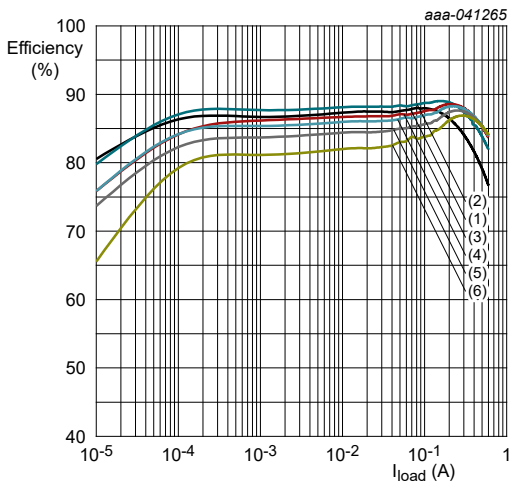

$V_{OUT} = 0.9\text{ V}$; $R_{SET} = 7.5\text{ k}\Omega$; $L = 2.2\text{ }\mu\text{H}$
 (1) $V_{VIN} = 1.8\text{ V}$; (2) $V_{VIN} = 2.5\text{ V}$; (3) $V_{VIN} = 3.3\text{ V}$;
 (4) $V_{VIN} = 3.6\text{ V}$; (5) $V_{VIN} = 4.2\text{ V}$; (6) $V_{VIN} = 5.0\text{ V}$

Fig. 13. Efficiency versus load current

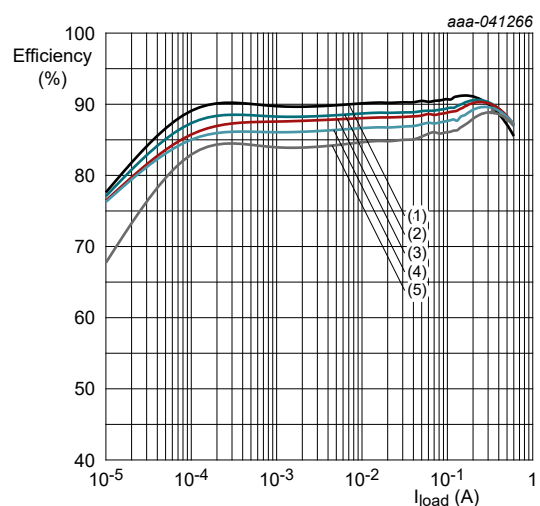

$V_{OUT} = 1.2\text{ V}$; $R_{SET} = 10.2\text{ k}\Omega$; $L = 2.2\text{ }\mu\text{H}$
 (1) $V_{VIN} = 2.5\text{ V}$; (2) $V_{VIN} = 3.3\text{ V}$; (3) $V_{VIN} = 3.6\text{ V}$;
 (4) $V_{VIN} = 4.2\text{ V}$; (5) $V_{VIN} = 5.0\text{ V}$

Fig. 14. Efficiency versus load current

1.8 V to 5.0 V, 600 mA, 220 nA ultra-low quiescent current, step-down converter

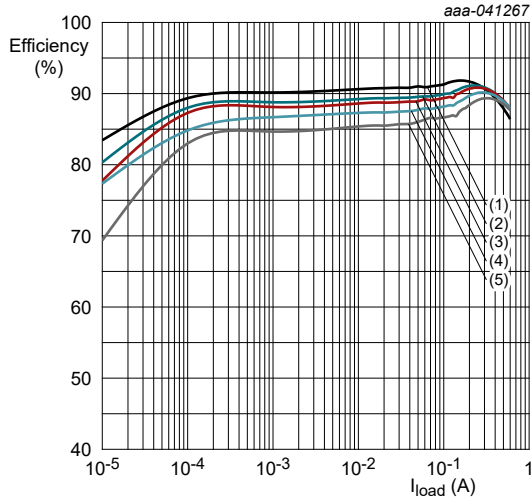

$V_{OUT} = 1.3\text{ V}$; $R_{SET} = 13.3\text{ k}\Omega$; $L = 2.2\text{ }\mu\text{H}$
 (1) $V_{VIN} = 2.5\text{ V}$; (2) $V_{VIN} = 3.3\text{ V}$; (3) $V_{VIN} = 3.6\text{ V}$;
 (4) $V_{VIN} = 4.2\text{ V}$; (5) $V_{VIN} = 5.0\text{ V}$

Fig. 15. Efficiency versus load current

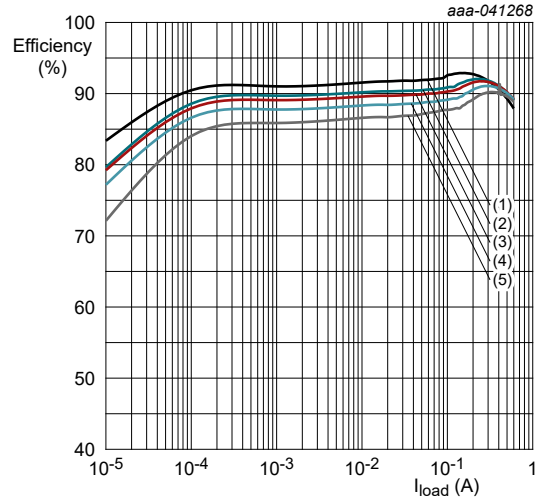

$V_{OUT} = 1.5\text{ V}$; $R_{SET} = 16.9\text{ k}\Omega$; $L = 2.2\text{ }\mu\text{H}$
 (1) $V_{VIN} = 2.5\text{ V}$; (2) $V_{VIN} = 3.3\text{ V}$; (3) $V_{VIN} = 3.6\text{ V}$;
 (4) $V_{VIN} = 4.2\text{ V}$; (5) $V_{VIN} = 5.0\text{ V}$

Fig. 16. Efficiency versus load current

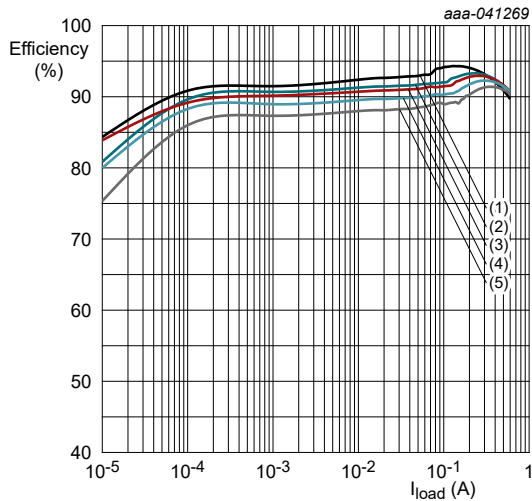

$V_{OUT} = 1.8\text{ V}$; $R_{SET} = 21.5\text{ k}\Omega$; $L = 2.2\text{ }\mu\text{H}$
 (1) $V_{VIN} = 2.5\text{ V}$; (2) $V_{VIN} = 3.3\text{ V}$; (3) $V_{VIN} = 3.6\text{ V}$;
 (4) $V_{VIN} = 4.2\text{ V}$; (5) $V_{VIN} = 5.0\text{ V}$

Fig. 17. Efficiency versus load current

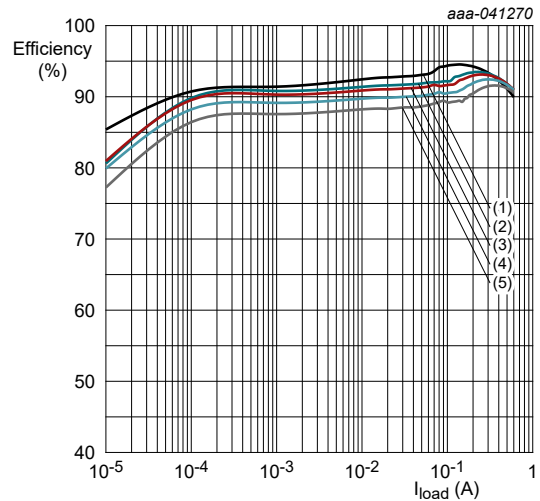

$V_{OUT} = 1.85\text{ V}$; $R_{SET} = 26.7\text{ k}\Omega$; $L = 2.2\text{ }\mu\text{H}$
 (1) $V_{VIN} = 2.5\text{ V}$; (2) $V_{VIN} = 3.3\text{ V}$; (3) $V_{VIN} = 3.6\text{ V}$;
 (4) $V_{VIN} = 4.2\text{ V}$; (5) $V_{VIN} = 5.0\text{ V}$

Fig. 18. Efficiency versus load current

1.8 V to 5.0 V, 600 mA, 220 nA ultra-low quiescent current, step-down converter

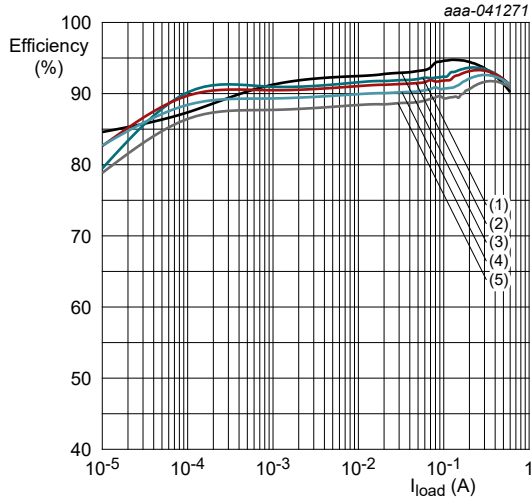

$V_{OUT} = 1.9\text{ V}$; $R_{SET} = 52.3\text{ k}\Omega$; $L = 2.2\text{ }\mu\text{H}$
 (1) $V_{VIN} = 2.5\text{ V}$; (2) $V_{VIN} = 3.3\text{ V}$; (3) $V_{VIN} = 3.6\text{ V}$;
 (4) $V_{VIN} = 4.2\text{ V}$; (5) $V_{VIN} = 5.0\text{ V}$

Fig. 19. Efficiency versus load current

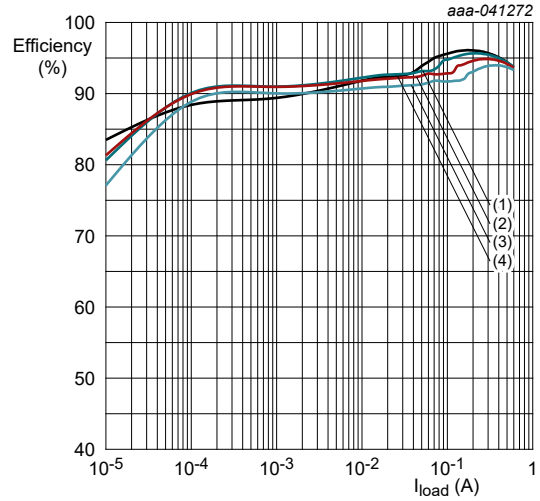

$V_{OUT} = 2.7\text{ V}$; $R_{SET} = 82.5\text{ k}\Omega$; $L = 2.2\text{ }\mu\text{H}$
 (1) $V_{VIN} = 3.3\text{ V}$; (2) $V_{VIN} = 3.6\text{ V}$; (3) $V_{VIN} = 4.2\text{ V}$;
 (4) $V_{VIN} = 5.0\text{ V}$

Fig. 20. Efficiency versus load current

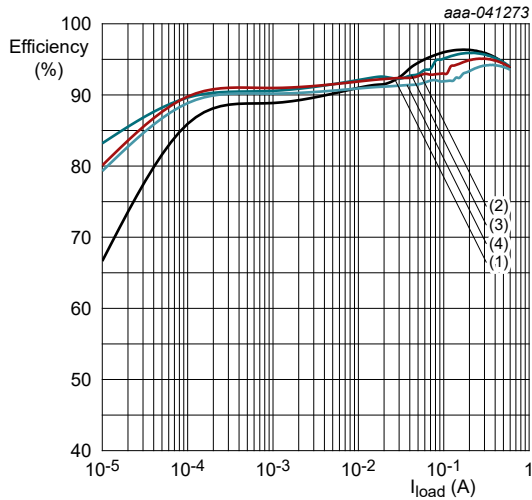

$V_{OUT} = 2.8\text{ V}$; $R_{SET} = 118\text{ k}\Omega$; $L = 2.2\text{ }\mu\text{H}$
 (1) $V_{VIN} = 3.3\text{ V}$; (2) $V_{VIN} = 3.6\text{ V}$; (3) $V_{VIN} = 4.2\text{ V}$;
 (4) $V_{VIN} = 5.0\text{ V}$

Fig. 21. Efficiency versus load current

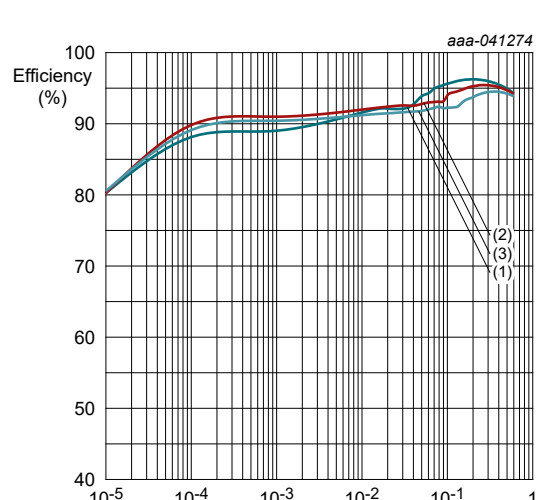

$V_{OUT} = 2.95\text{ V}$; $R_{SET} = 162\text{ k}\Omega$; $L = 2.2\text{ }\mu\text{H}$
 (1) $V_{VIN} = 3.6\text{ V}$; (2) $V_{VIN} = 4.2\text{ V}$; (3) $V_{VIN} = 5.0\text{ V}$

Fig. 22. Efficiency versus load current

1.8 V to 5.0 V, 600 mA, 220 nA ultra-low quiescent current, step-down converter

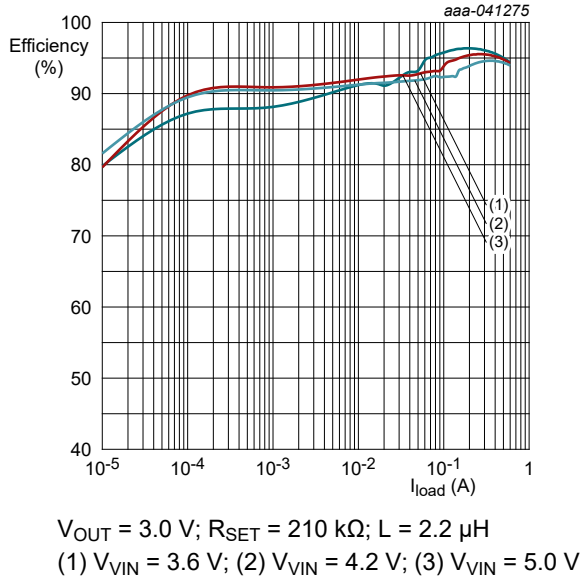

Fig. 23. Efficiency versus load current

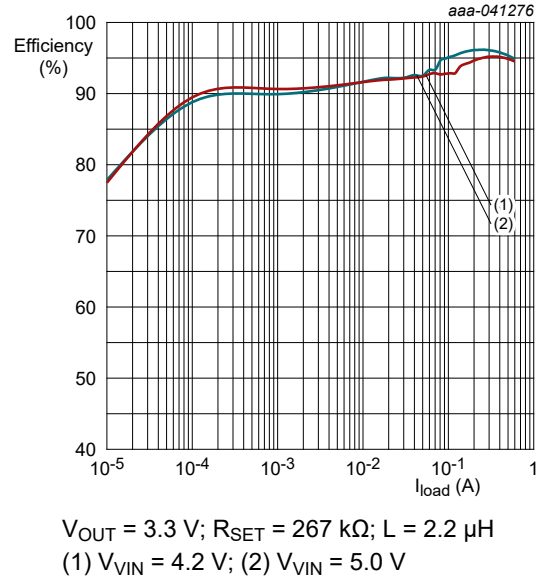

Fig. 24. Efficiency versus load current

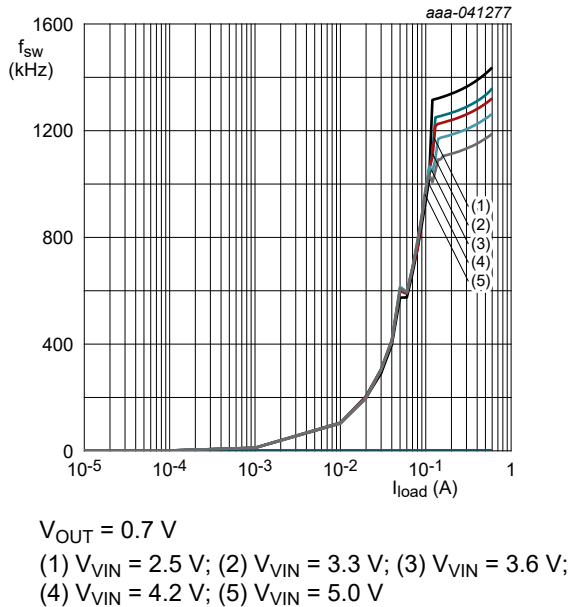

Fig. 25. Frequency versus load current

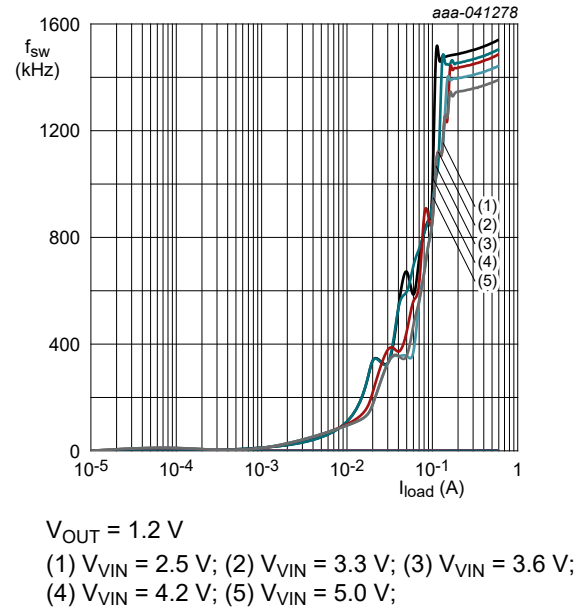
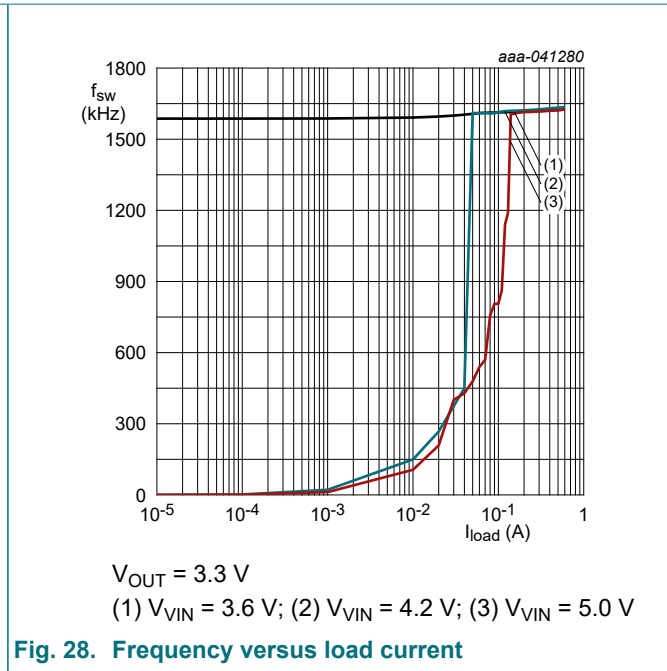
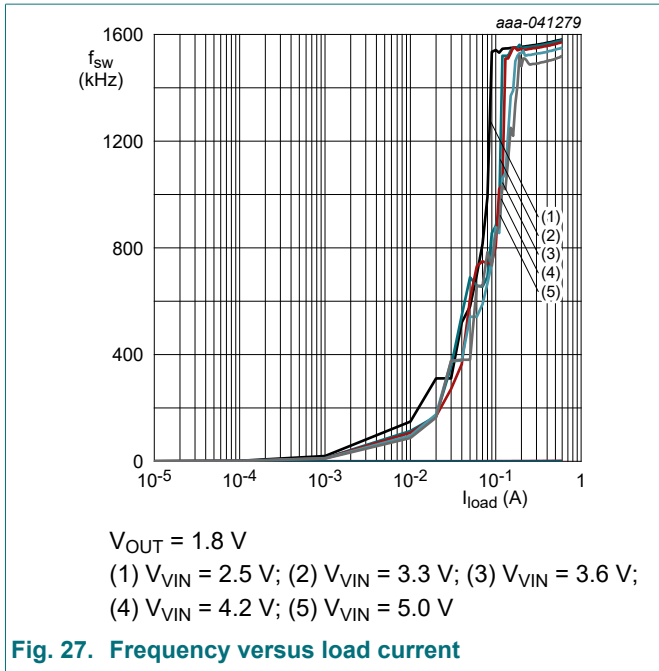
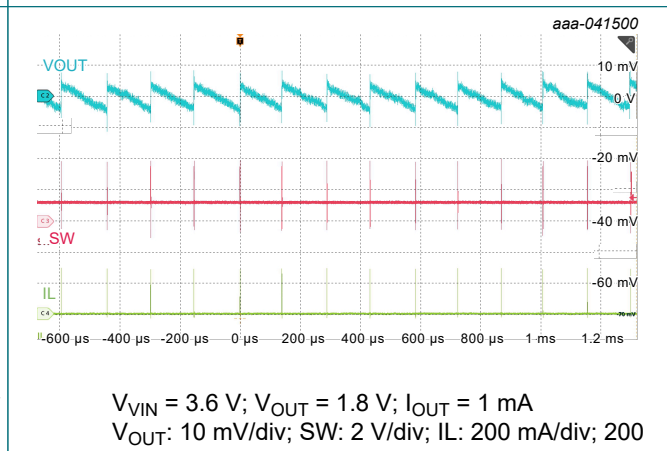
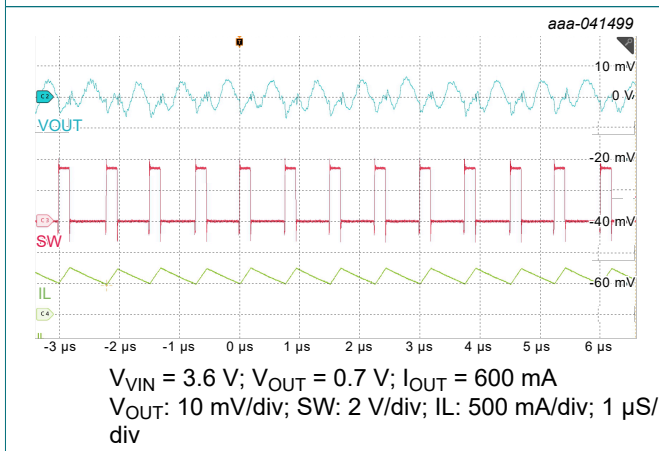
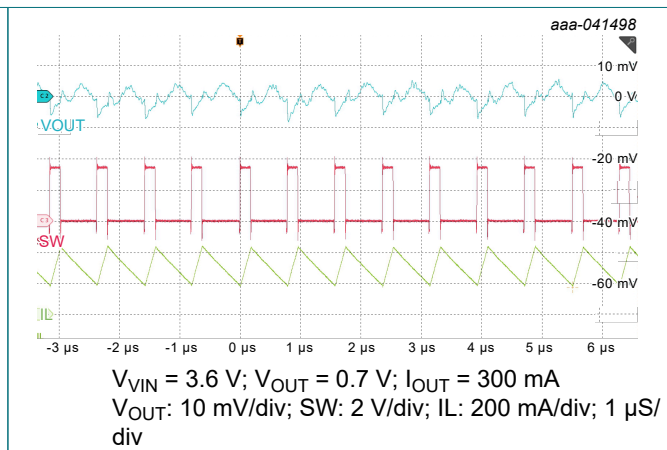
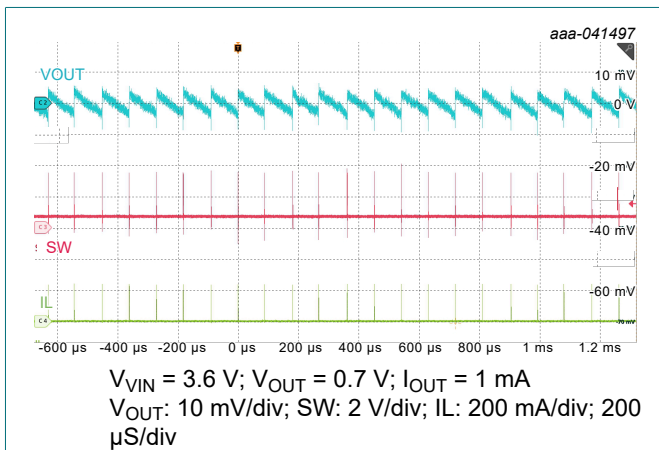

Fig. 26. Frequency versus load current

1.8 V to 5.0 V, 600 mA, 220 nA ultra-low quiescent current, step-down converter



17.2. Waveform testing



1.8 V to 5.0 V, 600 mA, 220 nA ultra-low quiescent current, step-down converter

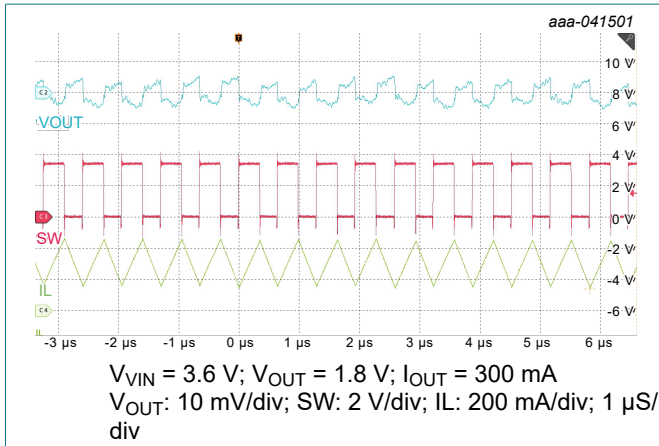

Fig. 33. Output ripple

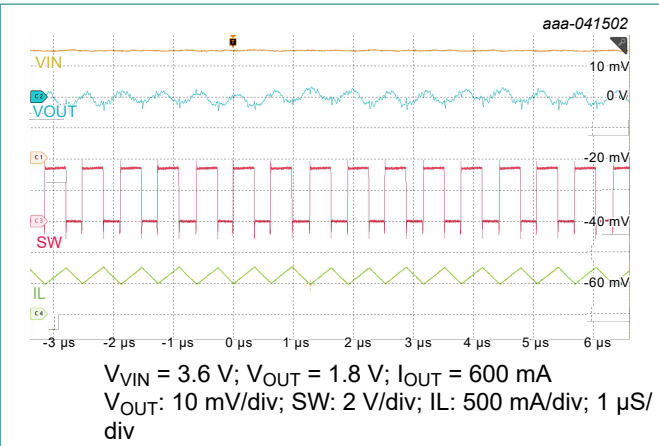

Fig. 34. Output ripple

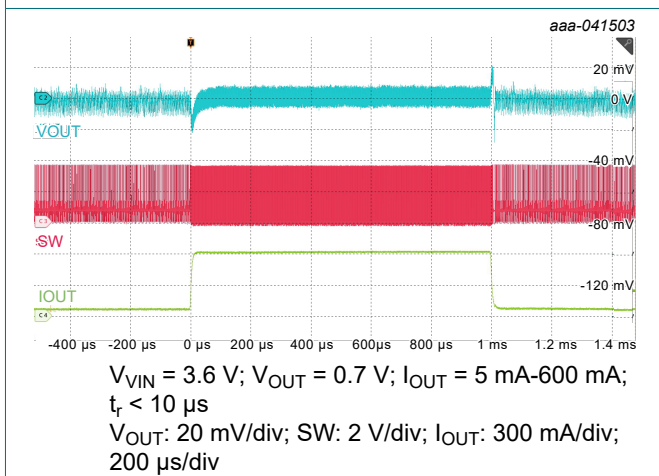

Fig. 35. Load transient

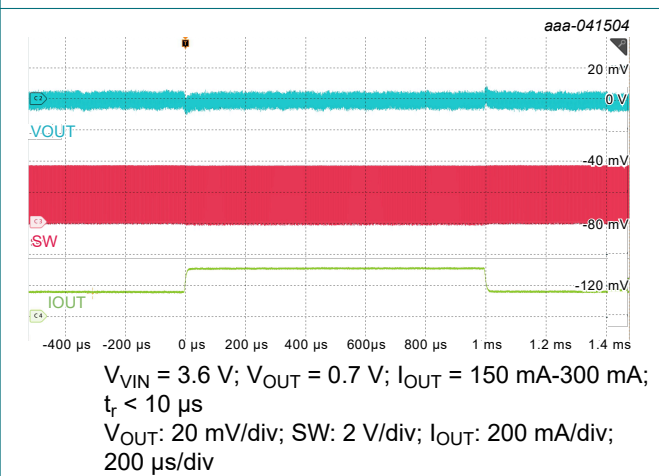

Fig. 36. Load transient

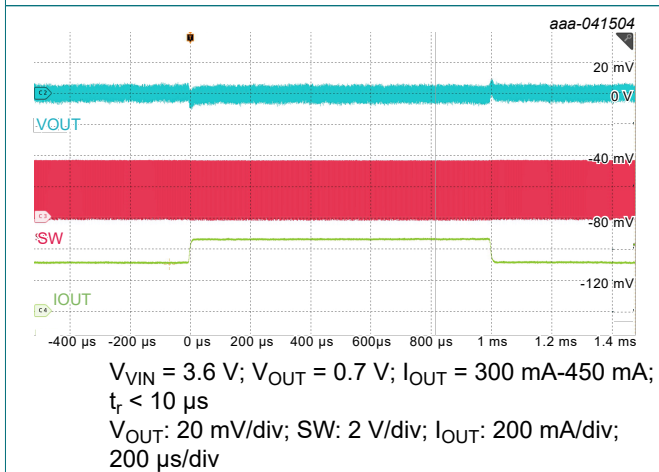

Fig. 37. Load transient

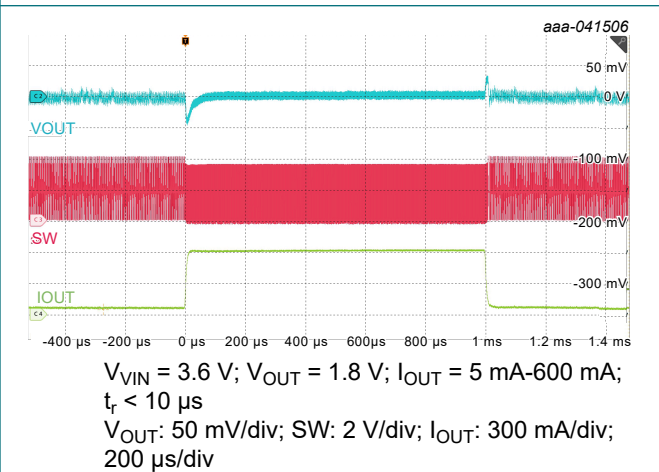

Fig. 38. Load transient

1.8 V to 5.0 V, 600 mA, 220 nA ultra-low quiescent current, step-down converter

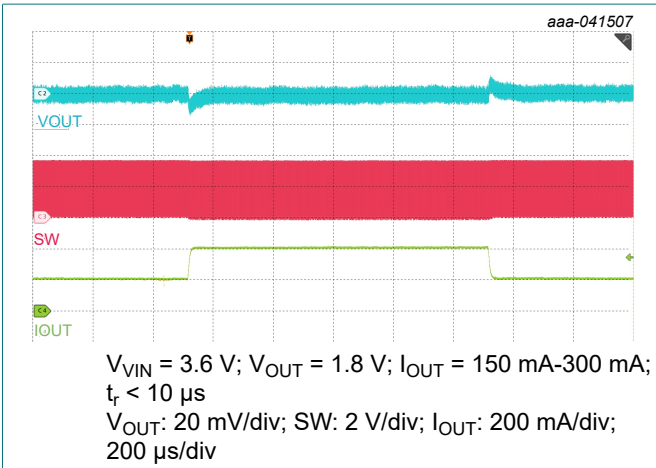

Fig. 39. Load transient

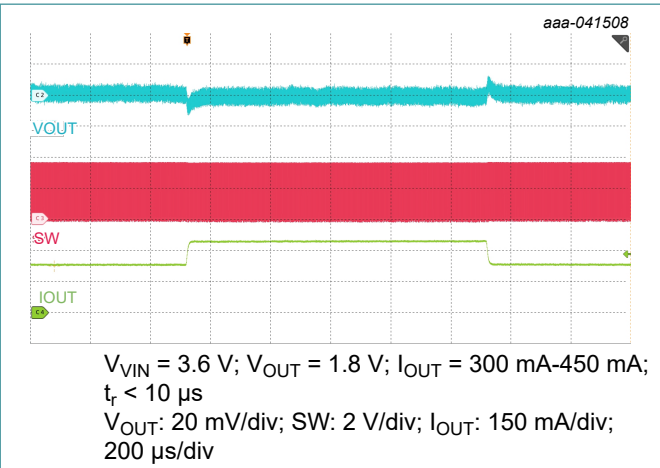

Fig. 40. Load transient

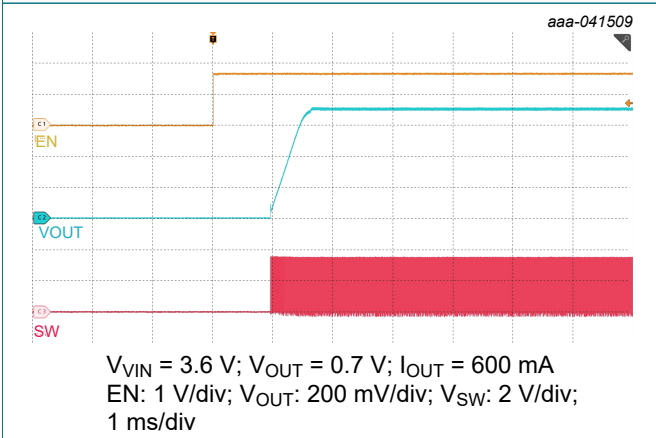

Fig. 41. EN startup

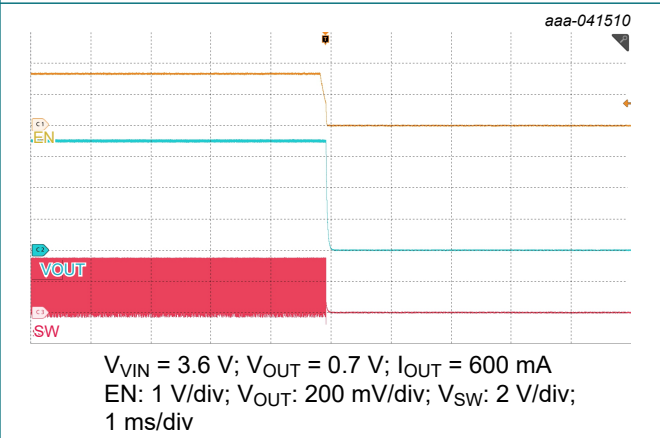

Fig. 42. EN OFF

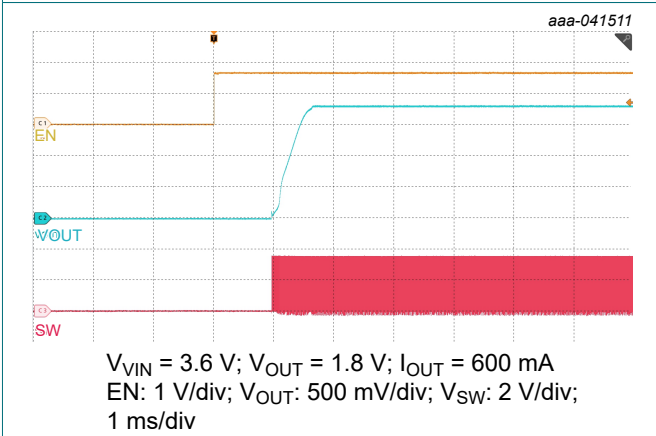

Fig. 43. EN startup

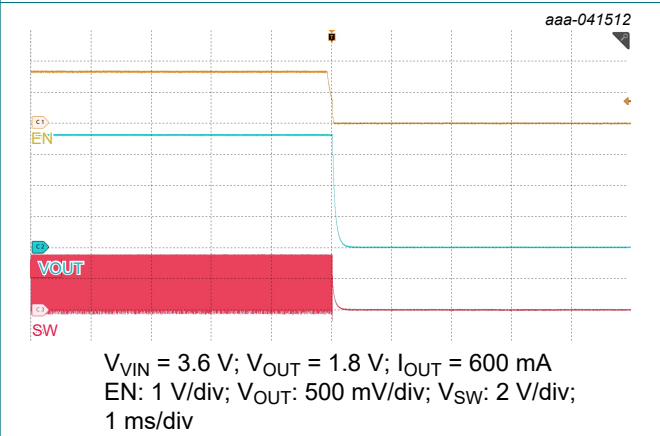
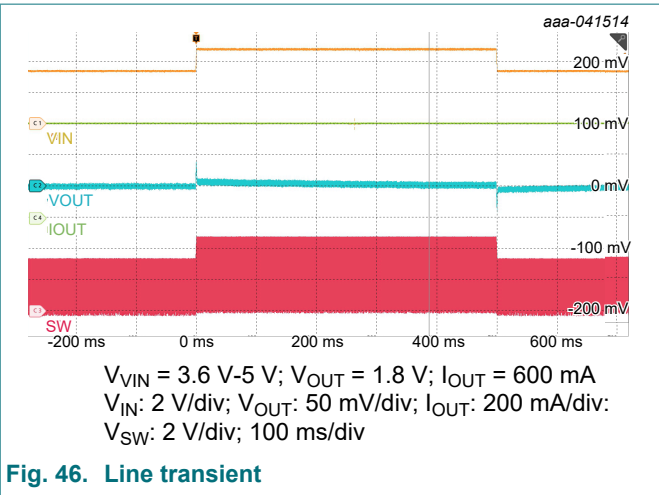
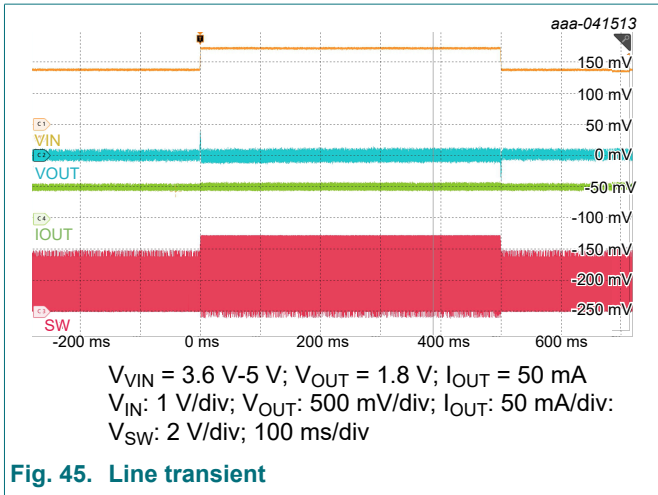

Fig. 44. EN OFF

1.8 V to 5.0 V, 600 mA, 220 nA ultra-low quiescent current, step-down converter



18. Package outline

WLCSP6: wafer level chip-size package; 6 bumps (3 x 2)

SOT8055-1

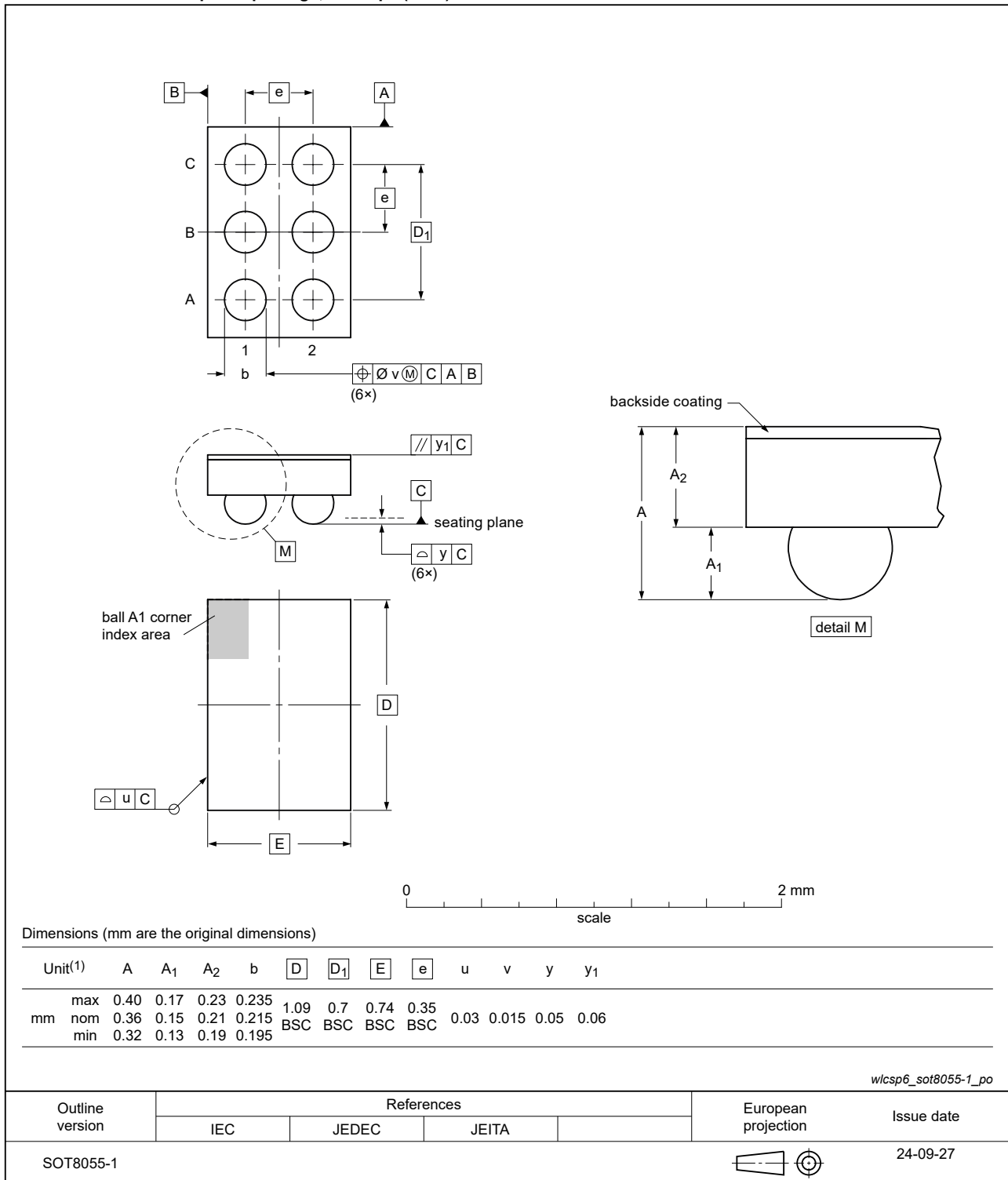

Fig. 47. Package outline SOT8055-1 (WLCSP6)

19. Abbreviations

Table 13. Abbreviations

Acronym	Description
CDM	Charged Device Model
DUT	Device Under Test
ESD	ElectroStatic Discharge
IOT	Internet Of Things
HBM	Human Body Model
NB-IOT	Narrow Band-Internet Of Things

20. Revision history

Table 14. Revision history

Document ID	Release date	Data sheet status	Change notice	Supersedes
NEX30606 v.1	20241120	Product data sheet	-	-

21. Legal information

Data sheet status

Document status [1][2]	Product status [3]	Definition
Objective [short] data sheet	Development	This document contains data from the objective specification for product development.
Preliminary [short] data sheet	Qualification	This document contains data from the preliminary specification.
Product [short] data sheet	Production	This document contains the product specification.

- [1] Please consult the most recently issued document before initiating or completing a design.
- [2] The term 'short data sheet' is explained in section "Definitions".
- [3] The product status of device(s) described in this document may have changed since this document was published and may differ in case of multiple devices. The latest product status information is available on the internet at <https://www.nexperia.com>.

Definitions

Draft — The document is a draft version only. The content is still under internal review and subject to formal approval, which may result in modifications or additions. Nexperia does not give any representations or warranties as to the accuracy or completeness of information included herein and shall have no liability for the consequences of use of such information.

Short data sheet — A short data sheet is an extract from a full data sheet with the same product type number(s) and title. A short data sheet is intended for quick reference only and should not be relied upon to contain detailed and full information. For detailed and full information see the relevant full data sheet, which is available on request via the local Nexperia sales office. In case of any inconsistency or conflict with the short data sheet, the full data sheet shall prevail.

Product specification — The information and data provided in a Product data sheet shall define the specification of the product as agreed between Nexperia and its customer, unless Nexperia and customer have explicitly agreed otherwise in writing. In no event however, shall an agreement be valid in which the Nexperia product is deemed to offer functions and qualities beyond those described in the Product data sheet.

Disclaimers

Limited warranty and liability — Information in this document is believed to be accurate and reliable. However, Nexperia does not give any representations or warranties, expressed or implied, as to the accuracy or completeness of such information and shall have no liability for the consequences of use of such information. Nexperia takes no responsibility for the content in this document if provided by an information source outside of Nexperia.

In no event shall Nexperia be liable for any indirect, incidental, punitive, special or consequential damages (including - without limitation - lost profits, lost savings, business interruption, costs related to the removal or replacement of any products or rework charges) whether or not such damages are based on tort (including negligence), warranty, breach of contract or any other legal theory.

Notwithstanding any damages that customer might incur for any reason whatsoever, Nexperia's aggregate and cumulative liability towards customer for the products described herein shall be limited in accordance with the Terms and conditions of commercial sale of Nexperia.

Right to make changes — Nexperia reserves the right to make changes to information published in this document, including without limitation specifications and product descriptions, at any time and without notice. This document supersedes and replaces all information supplied prior to the publication hereof.

Suitability for use — Nexperia products are not designed, authorized or warranted to be suitable for use in life support, life-critical or safety-critical systems or equipment, nor in applications where failure or malfunction of an Nexperia product can reasonably be expected to result in personal

injury, death or severe property or environmental damage. Nexperia and its suppliers accept no liability for inclusion and/or use of Nexperia products in such equipment or applications and therefore such inclusion and/or use is at the customer's own risk.

Quick reference data — The Quick reference data is an extract of the product data given in the Limiting values and Characteristics sections of this document, and as such is not complete, exhaustive or legally binding.

Applications — Applications that are described herein for any of these products are for illustrative purposes only. Nexperia makes no representation or warranty that such applications will be suitable for the specified use without further testing or modification.

Customers are responsible for the design and operation of their applications and products using Nexperia products, and Nexperia accepts no liability for any assistance with applications or customer product design. It is customer's sole responsibility to determine whether the Nexperia product is suitable and fit for the customer's applications and products planned, as well as for the planned application and use of customer's third party customer(s). Customers should provide appropriate design and operating safeguards to minimize the risks associated with their applications and products.

Nexperia does not accept any liability related to any default, damage, costs or problem which is based on any weakness or default in the customer's applications or products, or the application or use by customer's third party customer(s). Customer is responsible for doing all necessary testing for the customer's applications and products using Nexperia products in order to avoid a default of the applications and the products or of the application or use by customer's third party customer(s). Nexperia does not accept any liability in this respect.

Limiting values — Stress above one or more limiting values (as defined in the Absolute Maximum Ratings System of IEC 60134) will cause permanent damage to the device. Limiting values are stress ratings only and (proper) operation of the device at these or any other conditions above those given in the Recommended operating conditions section (if present) or the Characteristics sections of this document is not warranted. Constant or repeated exposure to limiting values will permanently and irreversibly affect the quality and reliability of the device.

Terms and conditions of commercial sale — Nexperia products are sold subject to the general terms and conditions of commercial sale, as published at <http://www.nexperia.com/profile/terms>, unless otherwise agreed in a valid written individual agreement. In case an individual agreement is concluded only the terms and conditions of the respective agreement shall apply. Nexperia hereby expressly objects to applying the customer's general terms and conditions with regard to the purchase of Nexperia products by customer.

No offer to sell or license — Nothing in this document may be interpreted or construed as an offer to sell products that is open for acceptance or the grant, conveyance or implication of any license under any copyrights, patents or other industrial or intellectual property rights.

Export control — This document as well as the item(s) described herein may be subject to export control regulations. Export might require a prior authorization from competent authorities.

Non-automotive qualified products — Unless this data sheet expressly states that this specific Nexperia product is automotive qualified, the product is not suitable for automotive use. It is neither qualified nor tested in accordance with automotive testing or application requirements. Nexperia accepts no liability for inclusion and/or use of non-automotive qualified products in automotive equipment or applications.

In the event that customer uses the product for design-in and use in automotive applications to automotive specifications and standards, customer (a) shall use the product without Nexperia's warranty of the product for such automotive applications, use and specifications, and (b) whenever customer uses the product for automotive applications beyond Nexperia's specifications such use shall be solely at customer's own risk, and (c) customer fully indemnifies Nexperia for any liability, damages or failed product claims resulting from customer design and use of the product for automotive applications beyond Nexperia's standard warranty and Nexperia's product specifications.

Translations — A non-English (translated) version of a document is for reference only. The English version shall prevail in case of any discrepancy between the translated and English versions.

Trademarks

Notice: All referenced brands, product names, service names and trademarks are the property of their respective owners.

Contents

1. General description	1
2. Features and benefits	1
3. Applications	1
4. Ordering information	2
5. Marking	2
6. Functional diagram	2
7. Pinning information	3
7.1. Pinning	3
7.2. Pin description	3
8. Device comparison	4
9. NEX30606 output voltage setting	4
10. Limiting values	4
11. Recommended operating conditions	5
12. Thermal Information	5
13. Electrical characteristics	5
14. Detailed description	7
14.1. Overview	7
14.2. Function block diagram	7
14.3. Feature description	7
14.3.1. COT control and PWM operation	7
14.3.2. Ultra low power (ULP) mode	8
14.3.3. Smart enable and shutdown (EN)	8
14.3.4. Soft start	9
14.3.5. Undervoltage lockout (UVLO)	9
14.3.6. Overcurrent protection function	9
14.3.7. Automatic recovery type short-circuit protection function (Hiccup mode)	9
14.3.8. Output voltage discharge	10
14.3.9. Thermal shutdown	10
15. Application implementation	10
15.1. Overview	10
15.2. Typical application	11
15.2.1. Design requirements	11
15.2.2. Inductor selection	11
15.2.3. Output capacitor selection	11
15.2.4. Input capacitor selection	12
16. Layout	12
16.1. Layout examples	12
17. Application graphs	13
17.1. Typical operating characteristics	13
17.2. Waveform testing	17
18. Package outline	21
19. Abbreviations	22
20. Revision history	22

21. Legal information

© Nexperia B.V. 2024. All rights reserved

For more information, please visit: <http://www.nexperia.com>

For sales office addresses, please send an email to: salesaddresses@nexperia.com

Date of release: 20 November 2024