

NF SERIES **RF** CO-AXIAL CONNECTORS

C15 type connectors for satellite broadcasting

Overview

C15 type connectors for satellite broadcasting (our company's NF series) conform with the specifications of Technical Standards RCZ-6015 of the Electronic Industries Association of Japan. The mechanical characteristics, electrical characteristics and environmental characteristics of the connectors are fully guaranteed.

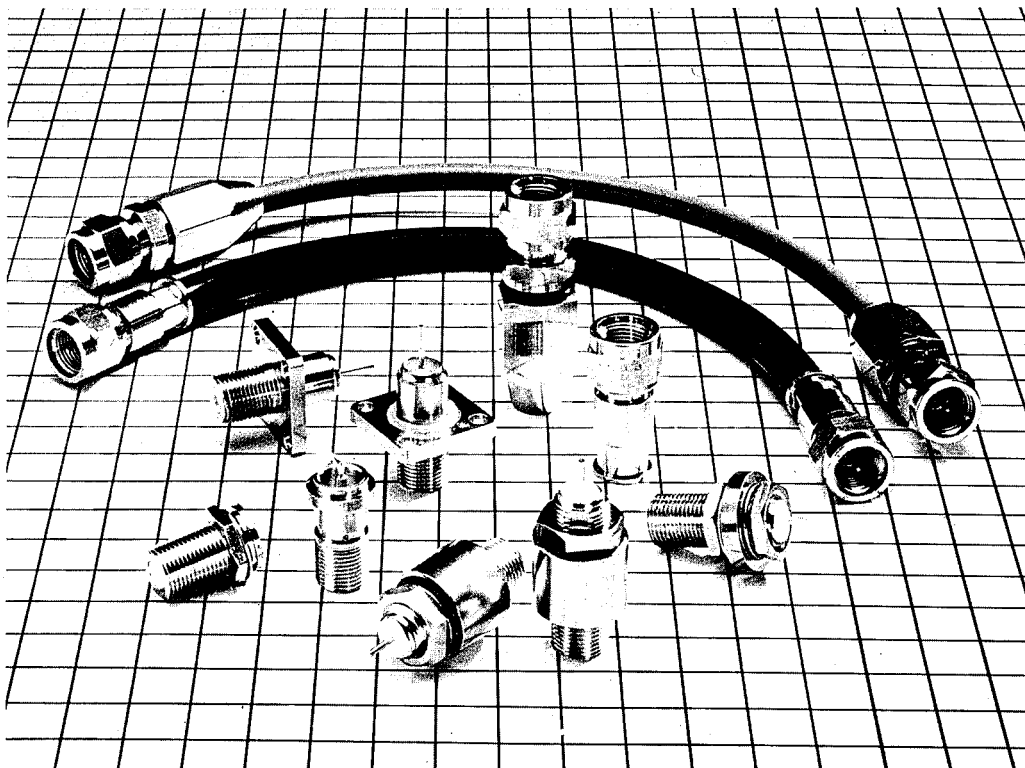

Characteristic Features

- (1) The V.S.W.R. is excellent: 1.2 or less at frequencies of up to 1.5GHz.
- (2) The plugs are all provided with pin contacts. (There is no need to work the tip of the center conductor of the cable to a conical shape.)
- (3) In both the plugs and receptacles, the center contacts are completely stationary (in both the axial direction and the circumferential direction), and adequate measures have been taken to deal with cable shrinkage caused by temperature variations.

Uses

DBS receiving systems, DBS shared receiving systems.

Performance characteristics

Items	Standard values
Impedance	75Ω
Insulation resistance	500MΩ or more at 500V DC
Contact resistance	5mΩ or less at both center and outer conductors at 1A DC.
Withstand voltage	AC 500V
Voltage standing wave ratio	1.2 or less at 0 ~ 1500MHz
Waterproof properties	0.2kgf/cm ² (waterproof connectors only)
Cable connecting strength	25kgf

Guide to products Waterproof plugs

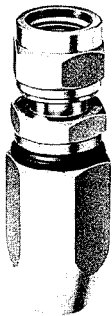

HRS No.	Part No.	Applicable cables
CL329-0002-2	NF-WP-TVEFCX	JIS C 3502 (TVEFCX)

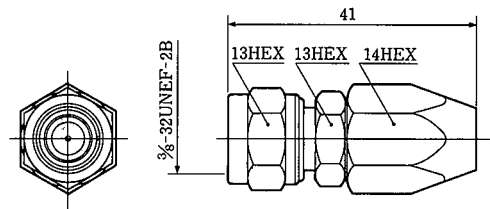

Non-waterproof plugs

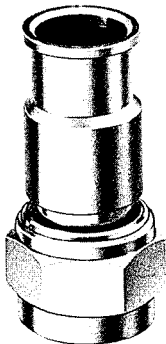

HRS No.	Part No.	Applicable cables
CL329-0012-6	NF-P-TVEFCX	JIS C 3502 (TVEFCX)
CL329-0011-3	NF-P-5CFB	JIS No.381 (5C-FB)

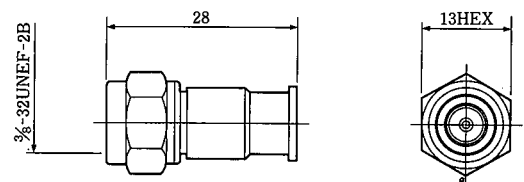

Waterproof receptacles

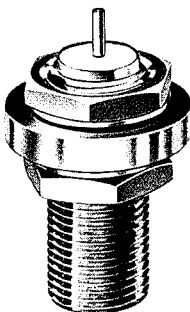

HRS No.	Part No.
CL329-0042-7	NF-WR-2A

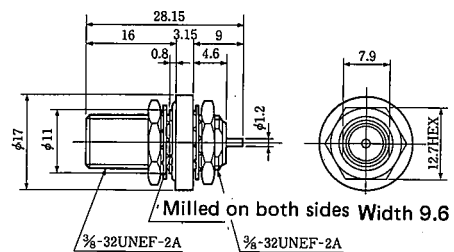

Note: The interior of the connector does not have a waterproof construction.

NF SERIES

RF CO-AXIAL CONNECTORS

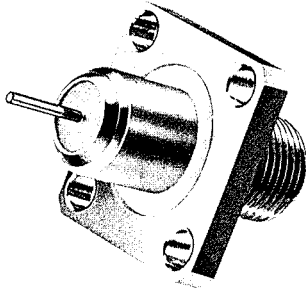

HRS No.	Part No.
CL329-0043-0	NF-WR-3

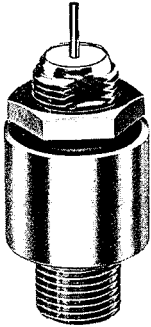
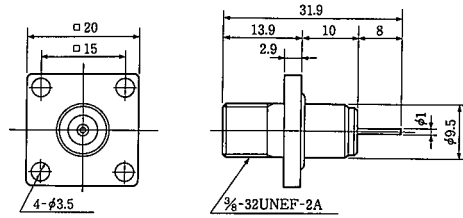

HRS No.	Part No.
CL329-0045-5	NF-WR-5

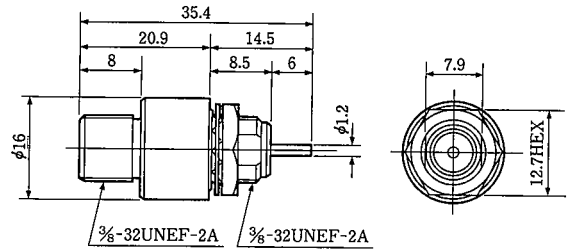

Non-waterproof receptacles

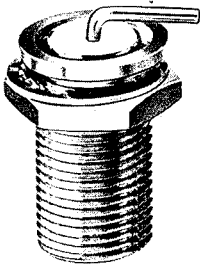

HRS No.	Part No.
CL329-0022-0	NF-R-2

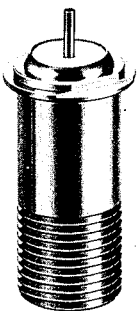
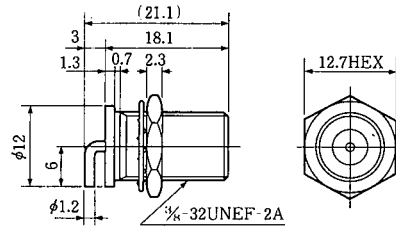

HRS No.	Part No.
CL329-0023-2	NF-R-3

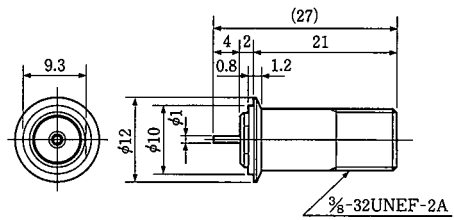

NF SERIES **RF** CO-AXIAL CONNECTORS

Dedicated tools for connecting wiring

Part No.	Center conductor	Outer conductor	Flaring tool
NF-WP-TVEFCX	NF-CCT	_____	NF-T-11
NF-P-TVEFCX		NF-T-1	
NF-P-5CFB			NF-T-12

Terminating model TVEFCX waterproof connectors

No.	Working drawing	Description
1		<ol style="list-style-type: none"> 1. Insert the cable into the tightening fixture as shown in the figure. 2. Cut off the outer cover at 12 ± 0.5 mm from the end. <p>Note: Be careful not to cut the outer conductor when cutting off the outer covering.</p>
2		<ol style="list-style-type: none"> 1. Fold the outer conductor onto the outer cover. 2. Insert the cylindrical part of the NF-T-11 between the insulation and outer conductor until the ends of the conductor and NF-T-11 fit closely as shown in the figure.
3		<ol style="list-style-type: none"> 1. Cut off the insulation about 12 mm from the cable end so that its end is flush with the end of the outer conductor. <p>Note: 1. Be careful not to cut the outer conductor when cutting off the insulation.</p> <p>2. Wipe off any extraneous matter on the center conductor with a cloth moistened with trichloroethane.</p>
4		<ol style="list-style-type: none"> 1. Fit the block of cord tube and male contact to the cable by pushing the cord tube with the end of the NF-T-11 with the male contact inserted into its $\phi 2.6$ hole.

Terminating model TVEFCX waterproof connectors

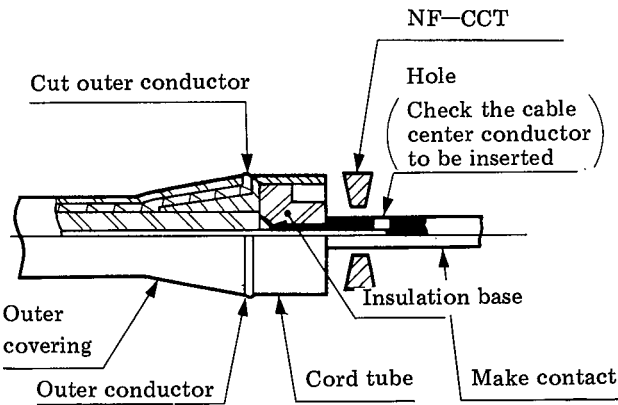
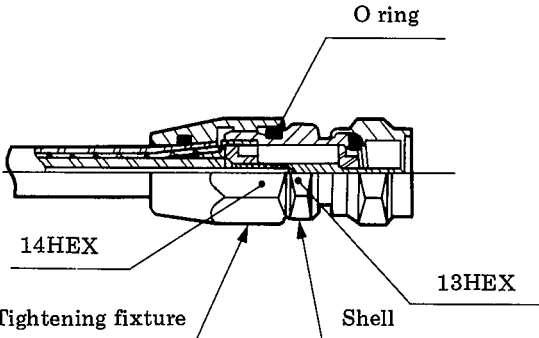
No.	Work drawing	Description
5		<ol style="list-style-type: none"> 1. Cut off the outer conductor at the point shown in the figure. 2. After confirming that the center conductor is visible through the hole in the male contact, crimp the contact with the NF-CCT.
6		<ol style="list-style-type: none"> 1. Fix the tightening fixture mounted in Step 1 on the cable to the block assembled in Step 5. With the tightening fixture fixed, screw the shell into the fixture with a spanner using torque of 30 to 40 kgf-cm or until it stops.

Terminating model TVEFCX non-waterproof connectors

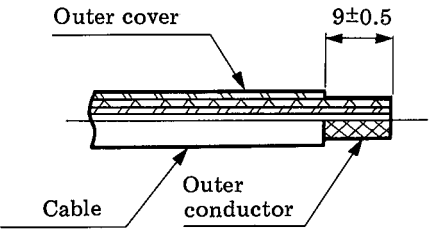
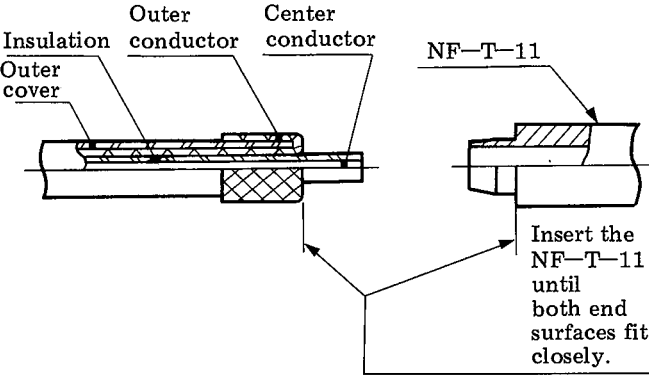
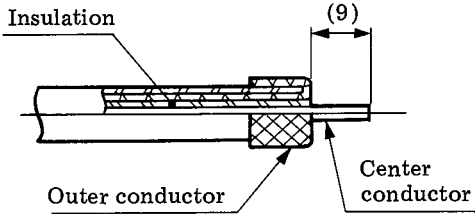
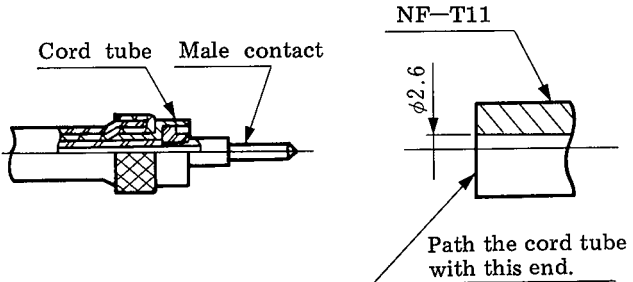
No.	Work drawing	Description
1	 <p>Outer cover</p> <p>9 ± 0.5</p> <p>Cable</p> <p>Outer conductor</p>	<ol style="list-style-type: none"> 1. Cut off the outer cover 9 ± 0.5 mm from the end. <p>Note: Be careful not to cut the outer conductor when cutting off the outer covering.</p>
2	 <p>Insulation</p> <p>Outer cover</p> <p>Outer conductor</p> <p>Center conductor</p> <p>NF-T-11</p> <p>Insert the NF-T-11 until both end surfaces fit closely.</p>	<ol style="list-style-type: none"> 1. Fold the outer conductor onto the outer cover. 2. Insert the cylindrical part of the NF-T-11 between the insulation and outer conductor until the ends of the conductor and NF-T-11 fit closely as shown in the figure.
3	 <p>Insulation</p> <p>(9)</p> <p>Outer conductor</p> <p>Center conductor</p>	<ol style="list-style-type: none"> 1. Cut off the insulation about 9 mm from the cable end such that its end is flush with the end of the outer conductor. <p>Note: 1. Be careful not to cut the outer conductor when cutting off the insulation.</p> <p>2. Wipe off any extraneous matter on the center conductor with a cloth moistened with trichloroethane.</p>
4	 <p>Cord tube</p> <p>Male contact</p> <p>NF-T-11</p> <p>φ2.6</p> <p>Path the cord tube with this end.</p>	<ol style="list-style-type: none"> 1. Fit the block of cord tube and male contact to the cable by pushing the cord tube with the end of the NF-T-11 with the male contact inserted into its φ2.6 hole.

Terminating model TVEFCX non-waterproof connectors

No.	Working drawing	Description
5		<ol style="list-style-type: none"> 1. Cut off the outer conductor 4 ± 1 mm from the end of the cord tube as shown in the figure. Note: Be careful not to cut the outer covering when cutting off the outer conductor. 2. After confirming that the center conductor is visible through the hole in the male contact, crimp the contact with the NF-CCT.
6		<ol style="list-style-type: none"> 1. Push the block assembled in Step 5 into the shell until it stops. Crimp the block at the center of dimension 6 shown in the Figure with an NF-T-1 hand press.

Terminating model 5 CFB non-waterproof connectors

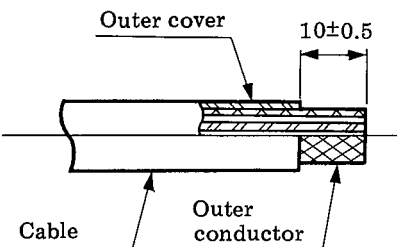
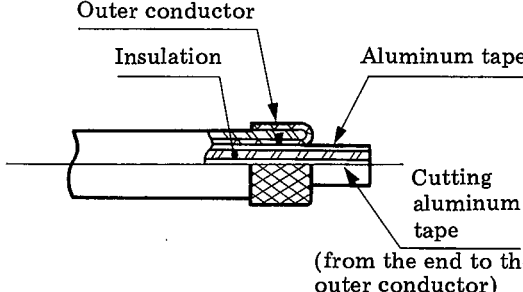
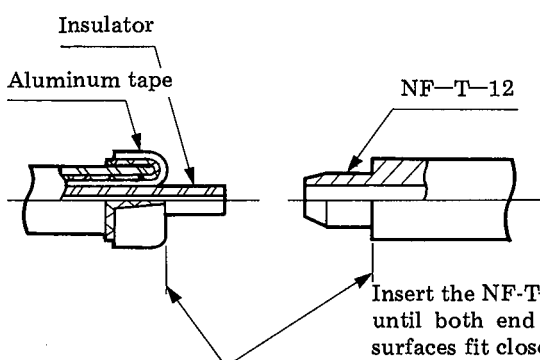
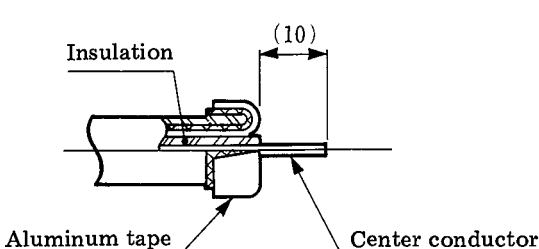
No.	Work drawing	Description
1	 <p>Outer cover</p> <p>10±0.5</p> <p>Cable</p> <p>Outer conductor</p>	<ol style="list-style-type: none"> 1. Cut off the outer cover at 10 ± 0.5 mm from the end. <p>Note: Be careful not to cut the outer conductor when cutting off the outer cover.</p>
2	 <p>Outer conductor</p> <p>Insulation</p> <p>Aluminum tape</p> <p>Cutting aluminum tape</p> <p>(from the end to the outer conductor)</p>	<ol style="list-style-type: none"> 1. Fold the outer conductor onto the outer cover. 2. Cut the aluminum tape along the cable axis from the outer conductor to the end; out the tape at two parts 180° distant on the periphery.
3	 <p>Insulator</p> <p>Aluminum tape</p> <p>NF-T-12</p> <p>Insert the NF-T-12 until both end surfaces fit closely.</p>	<ol style="list-style-type: none"> 1. Fold the aluminum tape onto the outer conductor folded in Step 2. 2. Insert the cylindrical part of the NF-T-12 between the insulation and aluminum tape until both end surfaces fit closely as shown in the Figure.
4	 <p>Insulation</p> <p>(10)</p> <p>Aluminum tape</p> <p>Center conductor</p>	<ol style="list-style-type: none"> 1. Cut off the insulation about 10 mm from the cable end so that its end is flush with the end of the outer conductor. <p>Note: Be careful not to cut the outer conductor when cutting off the insulation.</p> <ol style="list-style-type: none"> 2. Wipe off any extraneous matter on the center conductor with a cloth moistened with trichloroethans.

Terminating model 5CFB non-waterproof connectors

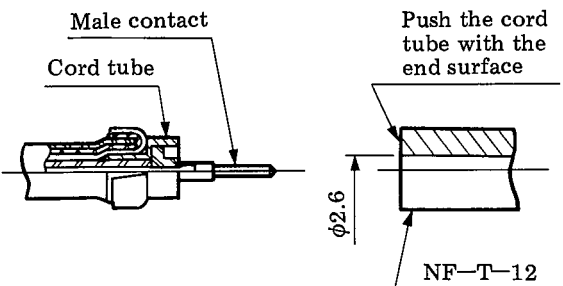
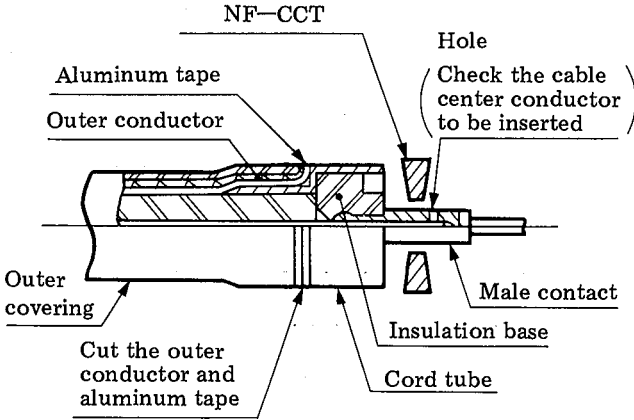
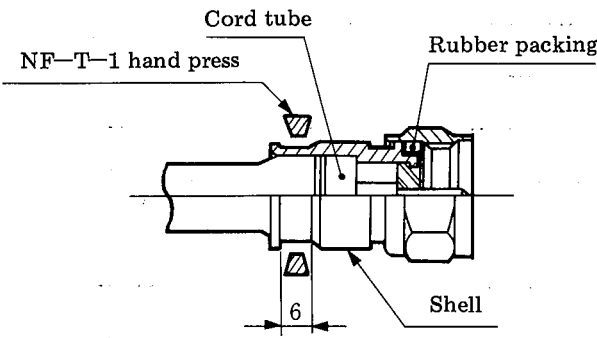
No.	Work drawing	Description
5		<ol style="list-style-type: none"> 1. Fit the block of cord tube and male contact to the cable by pushing the cord tube with the end of the NF-T-12 with the male contact inserted into its $\phi 2.6$ hole.
6		<ol style="list-style-type: none"> 1. Cut off the outer conductor and aluminum tape so that their peripheral surface is flush with that of the cord tube. 2. After confirming that the center conductor can be seen through the hole in the male contact, crimp the contact with the NF-OCT.
7		<ol style="list-style-type: none"> 1. Push the block assembled in Step 6 into the shell until it stops. Crimp the block at the center of the dimension 6 shown in the Figure with an NF-T-1 hand press.

MICROWAVE COMPONENTS

C15 type Accessories for Hirose satellite broadcasting

Materials and finish

Part name	Material	Finish
Body	Brass	Nickel plated
Insulator	Teflon	
Contact (male)	Brass	Gold plated
Contact (female)	Beryllium copper	Gold plated

Operational environment

Temperature: $-10^{\circ}\text{C} \sim +65^{\circ}\text{C}$

Humidity: $\sim 95\%$



NCJ-NFJ

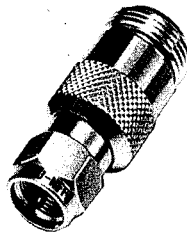

NCJ-NFP



NCP-NFP

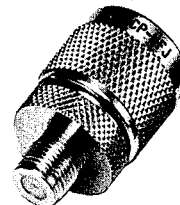

NCP-NFJ

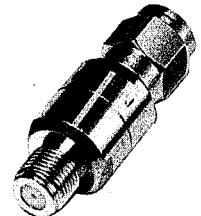

HDC-NF-PJ

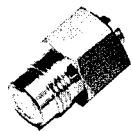

NF-TMJ-P



NF-TMP-P

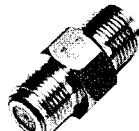

NF-A-JJ



NF-A-PJ-I



NF-TMP-I

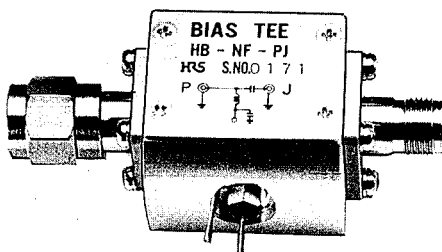



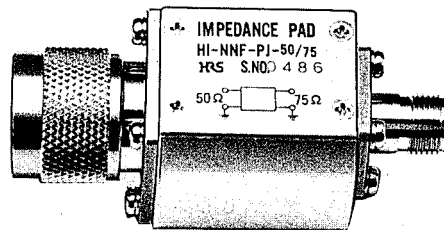

HB-NF-PJ

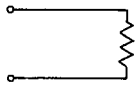
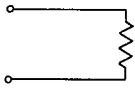
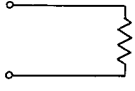
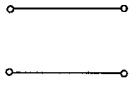
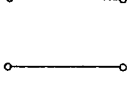
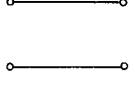

HI-NNF-PJ-50/75

MICROWAVE COMPONENTS

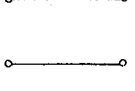
Specifications

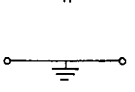
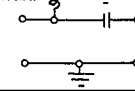
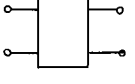
Part No.	Functions	Connectors	Schematic	Frequency range (MHz)	VSWR (Max.)	Insertion loss (dB) max.	Power (W)	weight (g)
NF-TMP-P	Resistive terminator	C15 plug	NF-P  75Ω	DC~1500	1.032	—	1/4	11
NF-TMJ-P	Resistive terminator	C15 jack	NF-J  75Ω	DC~1500	1.032	—	1/4	13
NF-TMP-1	Resistive terminator	C15 Push-on plug	NF-P*  75Ω	DC~1500	1.06	—	1/4	10
NF-A-PJ-1	Repeating connector	C15 jack / C15 push-on plug	NF-J / NF-P* 	DC~1500	1.06	—	—	10
NCJ-NFP	Repeating connector	75Ω N-type jack / C15 plug	NC-J / NF-P 	DC~1500	1.032	—	—	40
NCJ-NFJ	Repeating connector	75Ω N-type jack / C15 jack	NC-J / NF-J 	DC~1500	1.06	—	—	32
NCP-NFP	Repeating connector	75Ω N-type plug / C15 plug	NC-P / NF-P 	DC~1500	1.06	—	—	42
NCP-NFJ	Repeating connector	75Ω N-type plug / C15 jack	NC-P / NF-J 	DC~1500	1.06	—	—	38
NF-A-JJ	Repeating connector	C15 jack	NF-J / NF-J 	DC~1500	1.032	—	—	12
HDC-NF-PJ	DC CUT	C15 plug / C15 jack	NF-P / NF-J 	10~1500	1.20	0.4	—	35
HB-NF-PJ	Bias tee	C15 plug / C15 jack	NF-P / NF-J 	900~1500 1000~1350	1.20 1.10	0.4	1	81
HI-NNF-PJ-50/75	Impedance pad (λ/4 conversion)	50Ω N-type plug / C15 jack	NP (50Ω) / NF-J (75Ω) 	900~1500 1000~1350	1.25 1.20	0.4	1	108

*P: Push-on type.

MICROWAVE COMPONENTS

Dimensions

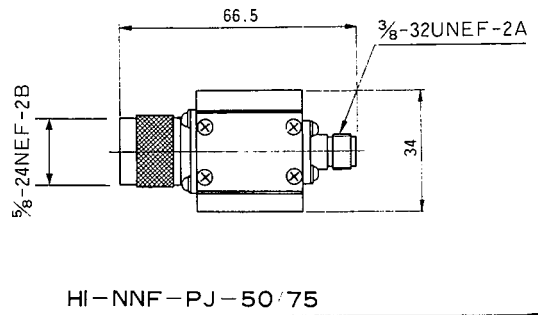
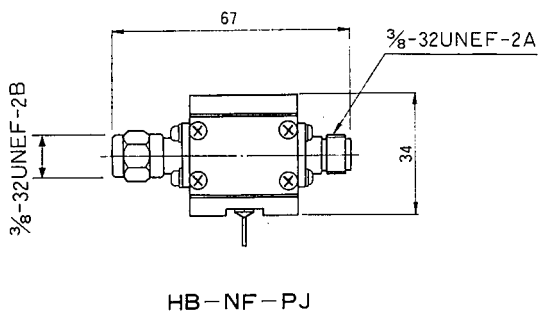
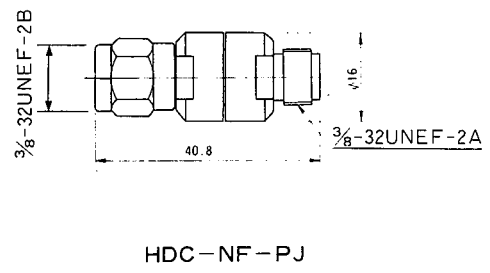
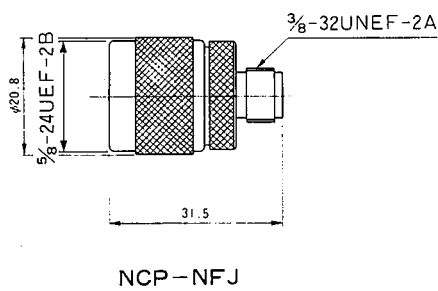
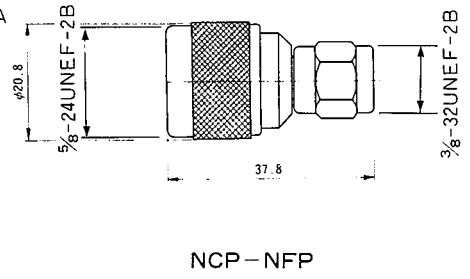
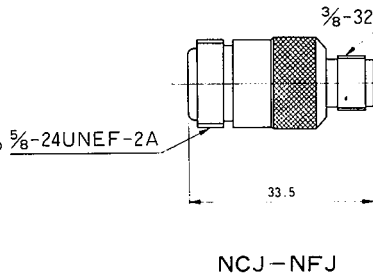
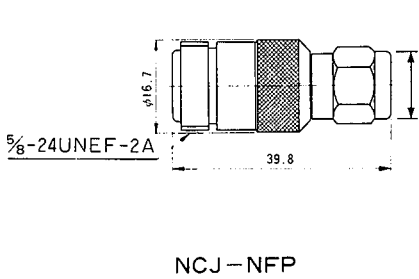
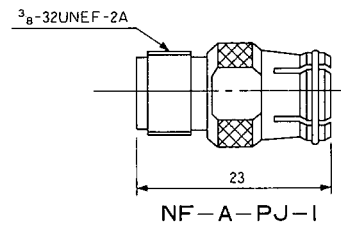
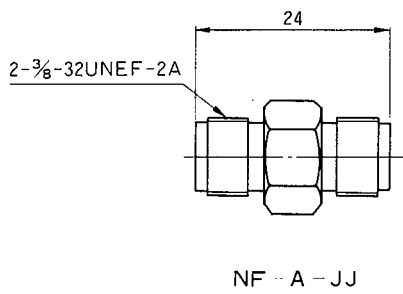
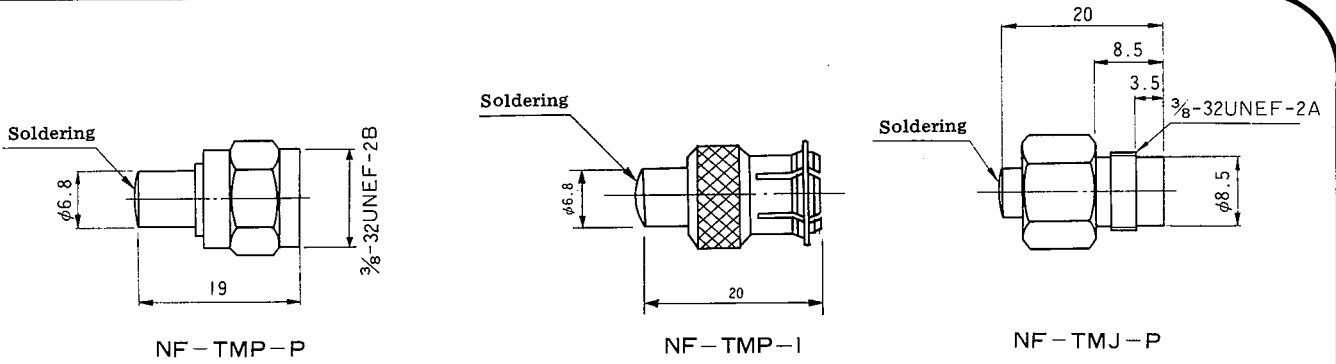

MICROWAVE COMPONENTS

High frequency data

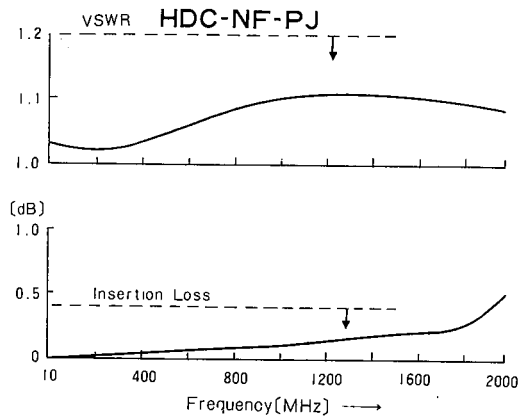
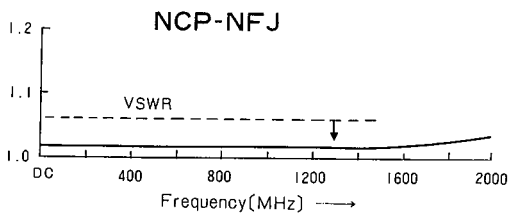
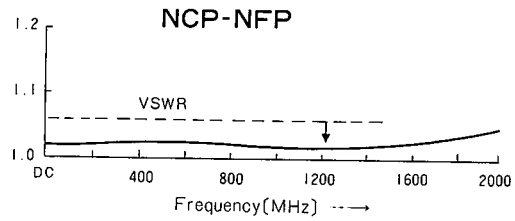
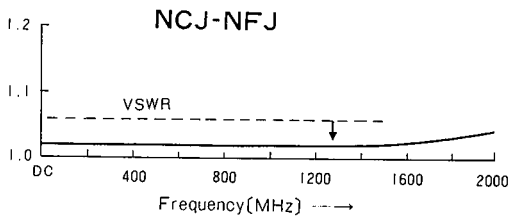
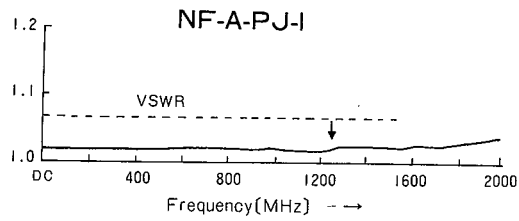
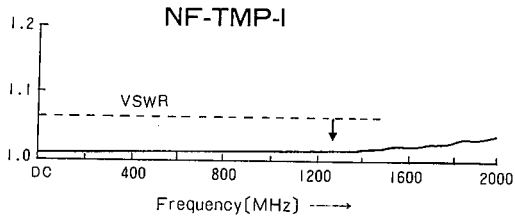
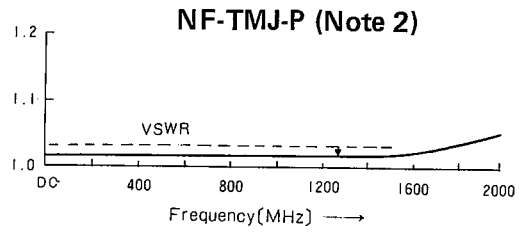
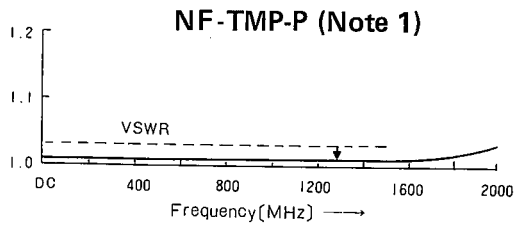

Note 1. NCJ-NFP and NF-A-JJ are included in measurements of NF-TMP-P.

Note 2. NCJ-NFP is included in measurements of NF-TMJ-P.

