

CHIP EMI SUPPRESSION FILTER

CHIP EMIFIL®

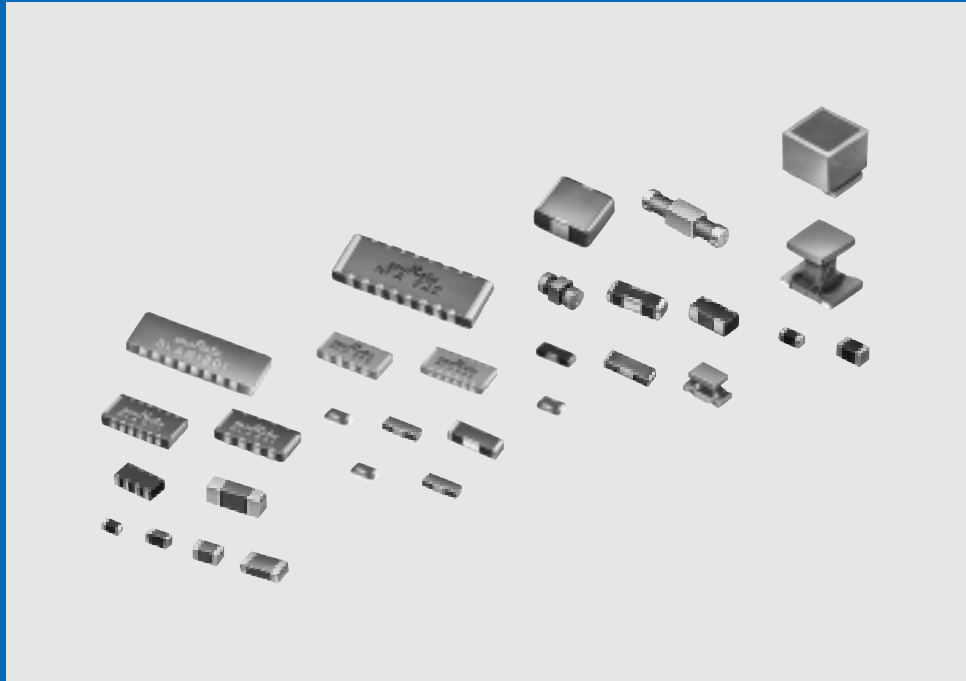

*Innovator
in Electronics*

**Murata
Manufacturing Co., Ltd.**

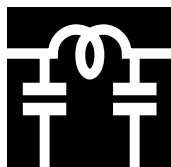

CHIP EMIFIL®

EMIFIL® is the trademark of Murata Manufacturing Co., Ltd.



Chip EMIFIL® Guide

The chip EMI suppression filter(EMIFIL®) is a noise suppression element designed to eliminate high-frequency noise. The filter is excellent for suppressing radiated noise,from digital circuits. It is also suitable to eliminate EMI/RFI

noise from other equipments. The filter consists of single capacitor, single inductor, or a capacitor and an inductor together,depending on the function.

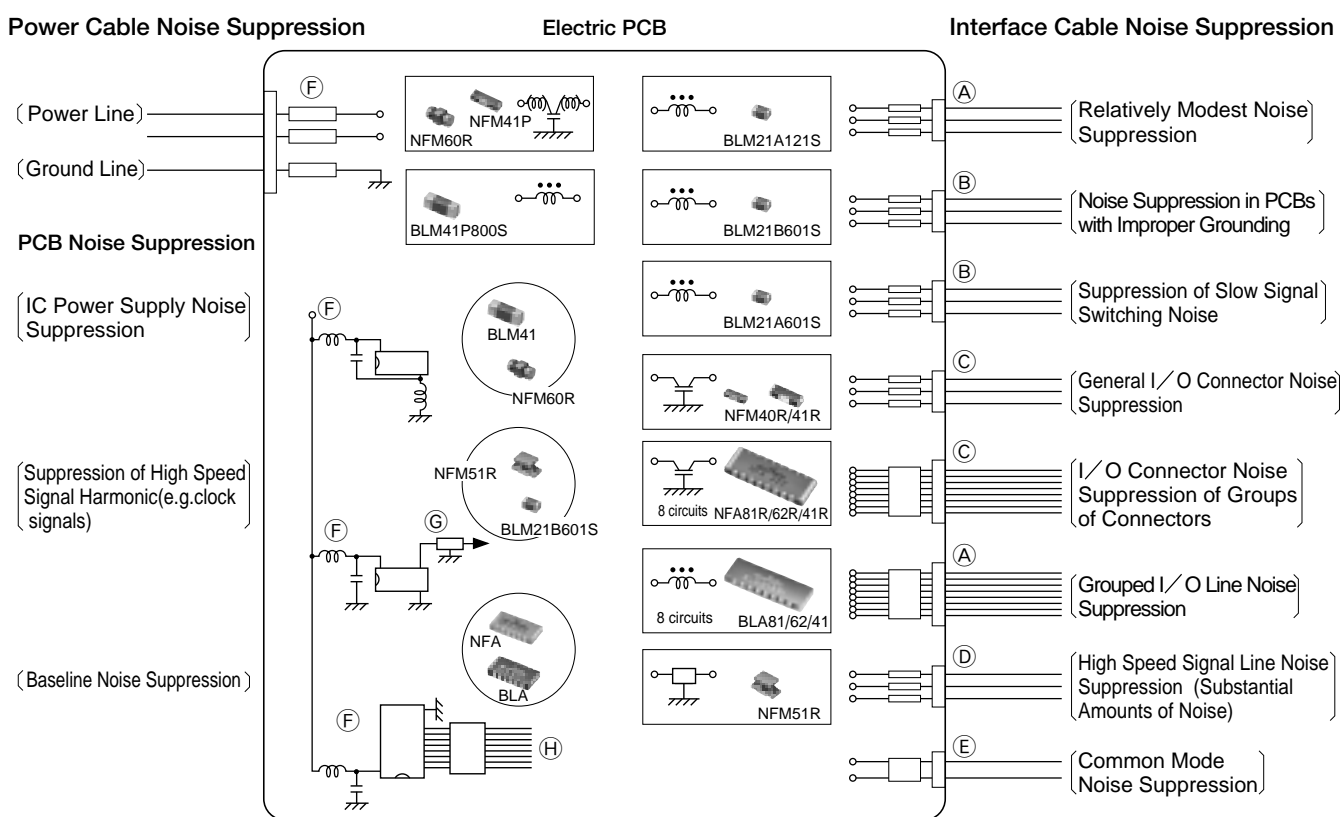

EXAMPLES OF CHIP EMI FILTERS IN APPLICATIONS



Mark	Application	Function	Recommended Chip EMIFIL®
(A)	I/O cable generating small amount of noise	Suppression of radiated noise from I/O cable	BLM11P / 21P / 31P / 41P, BLM10A / 11A / 21A / 31A Low-Impedance, BLA3216
(B)	I/O cable connected to poorly grounded PCB	Suppression of radiated noise from I/O cable	BLM11A / 21A / 31A High-Impedance BLM31B
(C)	I/O cable generating substantial amount of noise	Suppression of radiated noise from I/O cable	NFM39R / 40R / 41R NFA81R / 62R / 41R
(D)	I/O cable carrying high speed signals	Suppression of radiated noise from I/O cable	NFM839R / 51R, BLM11B / 21B, BLM21A / 31A Low-Impedance
(E)	I/O cable where common mode noise is critical	Suppression of radiated noise from I/O cable	PLM250 PLM3216K
(F)	DC power cable Individual IC power lines	Suppression of radiated noise from DC power cable, Suppression of noise near the power supply	NFM60R / 61R / 61RH, BLM41A Low-Impedance, BLM11P / 21P / 31P / 41P, NFM40P / 41P / 46P
(G)	High speed signal circuits (clock)	Suppression of radiated noise from PCB Reduction of overall system noise	NFM839R / 51R, BLM21A Low-Impedance BLA81 / 62 / 41, NFM39R / 40R / 41R, NFA81R / 62R / 41R
(H)	General signal lines, Bus lines	Suppression of radiated noise from PCB Reduction of overall system noise	BLM21A Low-Impedance, BLA81 / 62 / 41, BLA3216 NFM39R / 40R / 41R, NFA81R / 62R / 41R

■ PRODUCTS GUIDE

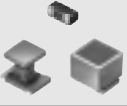
Type	Series	Dimensions		Effective Frequency Range							Page	
		(mm)	EIA Code	10kHz	100kHz	1MHz	10MHz	100MHz	1GHz	10GHz		
Inductor Type	Standard Type	BLM10A	1.0 ■ ±0.5	0402								4-19
		BLM11A	1.6 ■ ±0.8	0603								
		BLM21A	2.0 ■ ±1.25	0805								
		BLM31A	3.2 ■ ±1.6	1206								
		BLM41A	4.5 ■ ±1.6	1806								
		BLA3216A NEW	3.2 ■ ±1.6	1206								
		BLA81 (8 circuits array)	12.5 4.5	5018								
		BLA62/41 (6,4 circuits array)	6.3 3.2	2512								
	For High Speed Signal	BLM10B NEW	1.0 ■ ±0.5	0402								4-19
		BLM11B	1.6 ■ ±0.8	0603								
		BLM21B	2.0 ■ ±1.25	0805								
		BLM31B	3.2 ■ ±1.6	1206								
		BLA3216B NEW	3.2 ■ ±1.6	1206								
	For Large Current	BLM11P	1.6 ■ ±0.8	0603								4-19
		BLM21P	2.0 ■ ±1.25	0805								
BLM31P		3.2 ■ ±1.6	1206									
BLM41P		4.5 ■ ±1.6	1806									
Capacitor Type	Standard Type	NFM39R	2.0 ■ ±1.25	0805							23-26	
		NFM40R	3.2 ■ ±1.25	1205								
		NFM41R	4.5 ■ ±1.6	1806								
		NFA81R (8 circuits array)	12.5 4.5	5018								
		NFA62R/41R (6,4 circuits array)	6.3 3.2	2512								
	For Signal Line	NFM839R	2.0 ■ ±1.25	0805								29-32
		NFM51R	3.2 ■ ±1.6	1206								33-35
	For Large Current	NFM40P	3.2 ■ ±1.25	1205								36-37
		NFM41P	4.5 ■ ±1.6	1806								
		NFM46P	5.7 5.0	2220								
	T Filter for Large Current	NFM60R	3.2 ■ ±1.6	1206								38-39
		NFM61R(H)	6.8 ■ ±1.6	2706								
	With Varistor Function	VFM41R	4.5 ■ ±1.6	1806								40-41

Type	Series	Dimensions		Effective Frequency Range							Page	
		(mm)	EIA Code	10kHz	100kHz	1MHz	10MHz	100MHz	1GHz	10GHz		
Common Mode Choke Coil 	PLM3216K	3.2 ■ 11.6	1206									42-43
	PLM250S (PLM250H)	5.0 ■ 5.0 (3.6)	2020 (2014)									44-45
Chip Varistor 	VCM11R NEW	1.6 ■ +0.8	0603									46-47
	VCM21R NEW	2.0 ■ 11.25	0805									

Please refer to chip EMIFIL® usage conditions;

- Land Pattern P.48-50
- Solder Paste Printings and Adhesive Applications.... P.51-52
- Soldering..... P.53
- Cleaning, Operating Environment, Storage P.54
- Tape Dimensions P.55
- Design Kit P.56-58

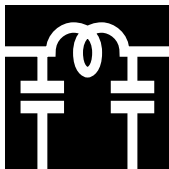

CHIP EMIFIL®

EMIFIL® is the trademark of Murata Manufacturing Co., Ltd.



Chip Ferrite Bead Inductor BLM Series

The chip ferrite bead inductor BLM series comprises ferrite bead inductors in the shape of a chip. This inductor generates a high impedance which at high frequencies mainly consists of a resistance element. The BLM series is effective in circuits without stable ground lines because the BLM series does not need a connection to ground. Chip sizes of 1.0×0.5, 1.6×0.8, 2.0×1.25, 3.2×1.6 and 4.5×1.6mm are cataloged. (The BLA series of array type chip ferrite bead inductors is also cataloged.) The nickel barrier structure of the external electrodes provides excellent solder heat resistance. Both flow and reflow soldering methods can be employed.

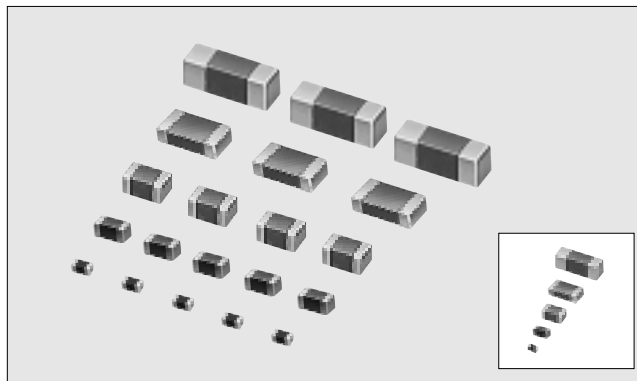

■FEATURES

The BLM series comprises the A series (standard), the B series (for high freq. signal), and the P series (high current).

1. BLM□□A series-Standard

The BLM-A series generates an impedance down to relatively low frequencies. The impedance consists of a resistance element and prevents signal ringing. Various impedances are available to match signal frequency.

2. BLM□□B series-High Frequency

The BLM-B series can minimize attenuation of the signal wave form due to its sharp impedance characteristics. Maximum signal frequencies ranging from 10MHz to 100MHz are available.

3. BLM□□P series-High Current

The BLM-P series can be used in high current circuits due to its low DC resistance. It can match power lines to a maximum of 6A DC.

■PART NUMBERING

(Please specify the part number when ordering.)

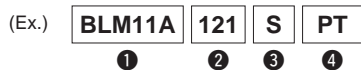

- ① Type
- ② Typical Impedance at 100MHz 121 : 120Ω
- ③ Other Characteristics
- ④ Packaging Code PT : Taped (∅ 180mm reel)
PT1 : Taped (∅ 330mm reel)
PB : Bulk package

■EQUIVALENT CIRCUIT DIAGRAM

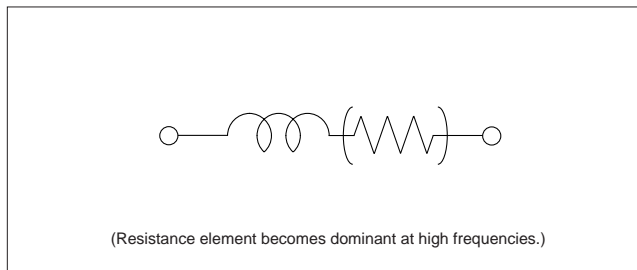

SELECTION GUIDE

● BLM□□A series-Standard • BLM□□P series-High Current

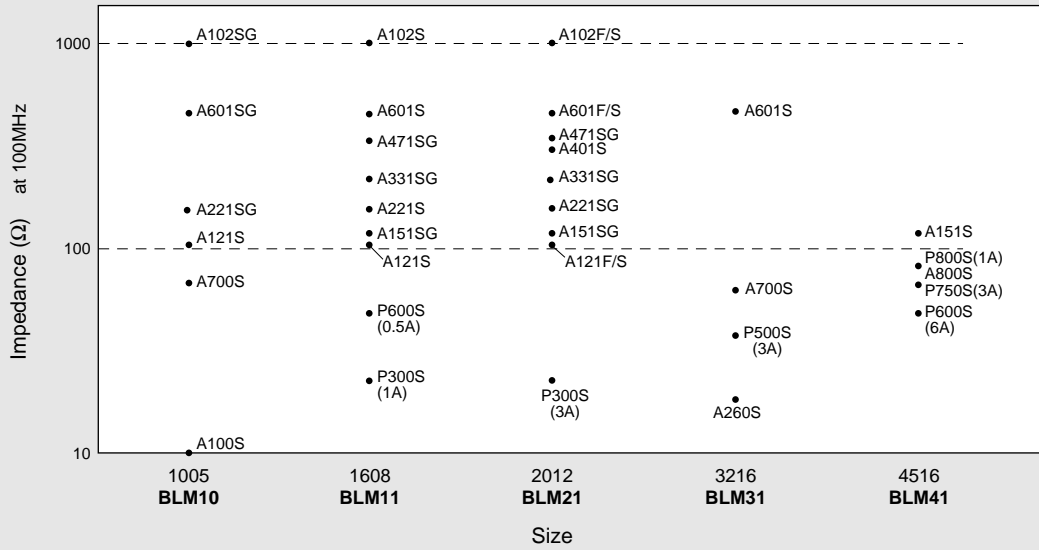

● BLM□□B series-High Frequency

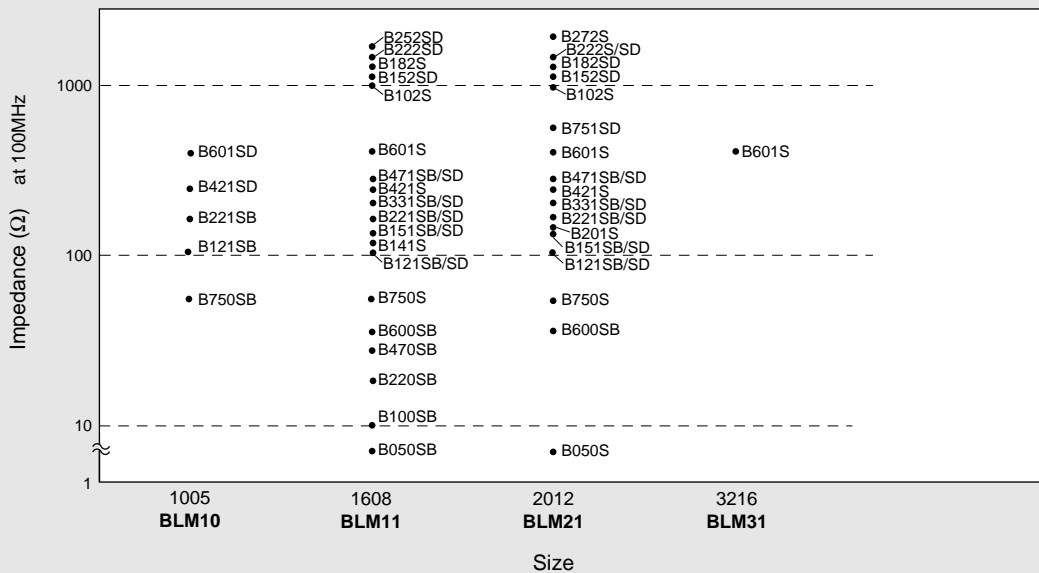

DIFFERENCE BETWEEN A SERIES AND B SERIES

The BLM□□B series has sharp impedance characteristics and it does not affect the signal frequency. So, BLM□□B series can suppress noise without distorting the wave-form.

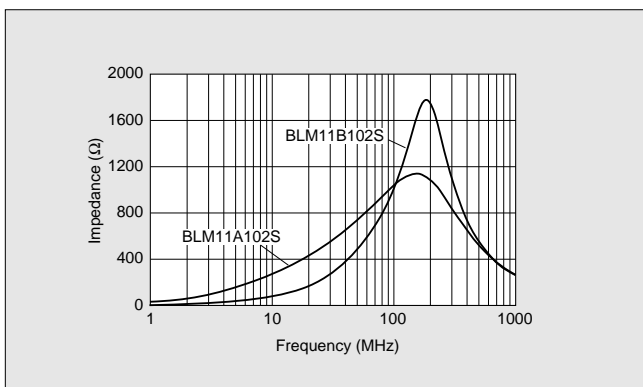

DERATING

When the BLM□□P series is for high-current used in operating temperatures exceeding +85°C, derating of current is necessary. Please apply the derating curve shown below according to the operating temperature.

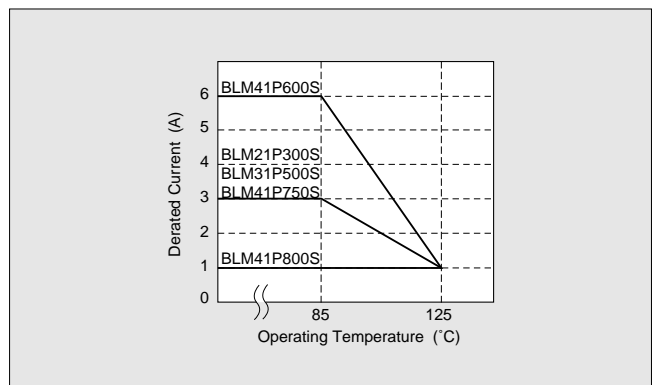

■BLM SERIES

Type	Size (mm)	Part Number	Impedance (Ω) (Typ.) at 100MHz	Rated Current (mA)	
BLM□□A Series -Standard	1.0×0.5	BLM10A100S	10	500	
		BLM10A700S	70	200	
		BLM10A121S	120		
		NEW BLM10A221SG	220	100	
		NEW BLM10A601SG	600	50	
		NEW BLM10A102SG	1000		
	BLM11A121S	120	200		
	NEW BLM11A151SG	150			
	BLM11A221S	220			
	NEW BLM11A331SG	330			
	NEW BLM11A471SG	470			
	BLM11A601S	600			
	BLM11A102S	1000	100		
	2.0×1.25	2.0×1.25	BLM21A121F	120	200
			BLM21A121S		
			NEW BLM21A151SG	150	
			NEW BLM21A221SG	220	
			NEW BLM21A331SG	330	
			BLM21A401S	400	
			NEW BLM21A471SG	470	
			BLM21A601F	600	
			BLM21A601S		
			BLM21A102F	1000	
	BLM21A102S				
	3.2×1.6	3.2×1.6	BLM31A260S	26	500
			BLM31A700S	70	200
			BLM31A601S	600	
	4.5×1.6	4.5×1.6	BLM41A800S	80	500
BLM41A151S			150	200	
BLM□□B Series -High Frequency (Sharp impedance characteristic)	1.0×0.5	NEW BLM10B750SB	75	100	
		NEW BLM10B121SB	120		
		NEW BLM10B221SB	220		
		NEW BLM10B421SD	420		
		NEW BLM10B601SD	600		
	1.6×0.8	1.6×0.8	NEW BLM11B050S	5	700
			NEW BLM11B100SB	10	500
			NEW BLM11B220SB	22	
			NEW BLM11B470SB	47	
			NEW BLM11B600SB	60	200
			BLM11B750S	75	
			NEW BLM11B121SB	120	
			NEW BLM11B121SD		
			BLM11B141S	140	
			NEW BLM11B151SB	150	
			NEW BLM11B151SD		
			NEW BLM11B221SB	220	
			NEW BLM11B221SD		
			NEW BLM11B331SB	330	
			NEW BLM11B331SD		
			BLM11B421S	420	
			NEW BLM11B471SB	470	50
			NEW BLM11B471SD		
			BLM11B601S	600	200
			BLM11B102S	1000	100
			NEW BLM11B152SD	1500	50
			BLM11B182S	1800	
			NEW BLM11B222SD	2200	
NEW BLM11B252SD	2500				

Type	Size (mm)	Part Number	Impedance (Ω) (Typ.) at 100MHz	Rated Current (mA)
BLM□□B Series -High Frequency (Sharp impedance characteristic)	2.0×1.25	BLM21B050S	5	500
		NEW BLM21B600SB	60	200
		BLM21B750S	75	
		NEW BLM21B121SB	120	
		NEW BLM21B121SD		
		NEW BLM21B151SB	150	
		NEW BLM21B151SD		
		BLM21B201S	200	
		NEW BLM21B221SB	220	
		NEW BLM21B221SD		
		NEW BLM21B331SB	330	
		NEW BLM21B331SD		
		BLM21B421S	420	
		NEW BLM21B471SB	470	
		NEW BLM21B471SD		
		BLM21B601S	600	
		BLM21B751SD	750	
		BLM21B102S	1000	
		NEW BLM21B152SD	1500	
		NEW BLM21B182SD	1800	
		BLM21B222S	2200	
NEW BLM21B222SD				
BLM21B272S	2700			
3.2×1.6	BLM31B601S	600		
BLM□□P Series -High Current	1.6×0.8	BLM11P300S	30	1000
		BLM11P600S	60	500
	2.0×1.25	BLM21P300S	30	3000
		3.2×1.6	BLM31P500S	
	4.5×1.6	BLM41P600S	60	6000
		BLM41P750S	75	3000
		BLM41P800S	80	1000

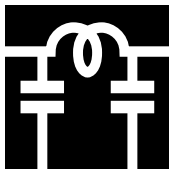

CHIP EMIFIL®

EMIFIL® is the trademark of Murata Manufacturing Co., Ltd.



Chip Ferrite Bead Inductor BLM10 Series

■ SPECIFICATIONS

Part Number	Maximum Signal Frequency (MHz)	Impedance (Ω) (Typ.) at 100MHz	Rated Current (mA)	DC Resistance (Ω max.)	Operating Temp. Range (°C)
BLM10A100S	—	10	500	0.05	-55 to +125
BLM10A700S		70	200	0.40	
BLM10A121S		120		0.50	
BLM10A221SG		220	100	0.70	
BLM10A601SG		600		1.10	
BLM10A102SG		1000		1.50	
BLM10B750SB	140	75	100	0.8	
BLM10B121SB	90	120	50	1.1	
BLM10B221SB	60	220		1.4	
BLM10B421SD	20	420		1.3	
BLM10B601SD		600		1.5	

■ DIMENSIONS

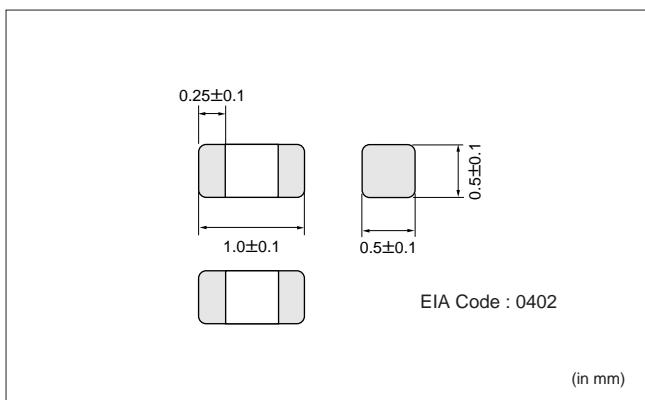

■ IMPEDANCE-FREQUENCY CHARACTERISTICS (TYPICAL)

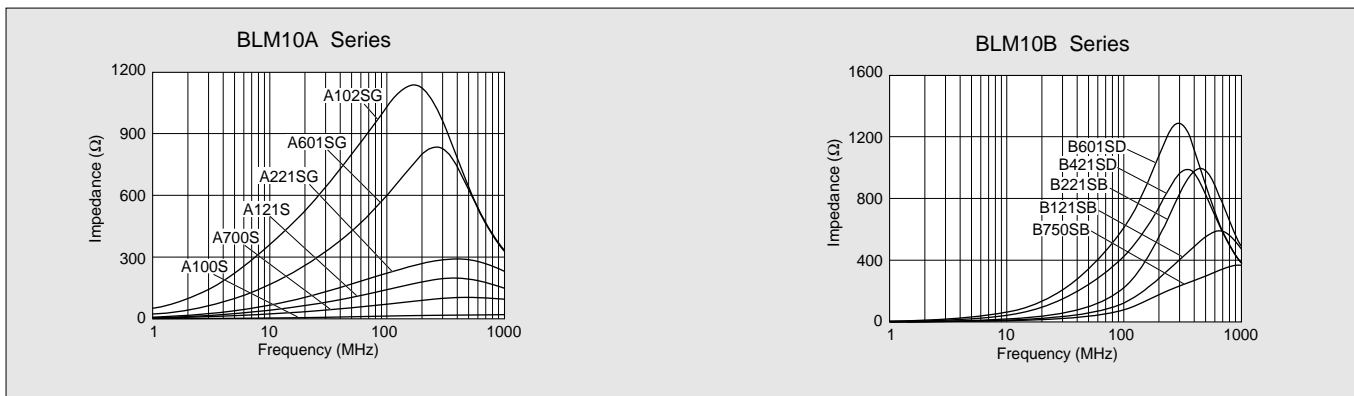

■ IMPEDANCE-FREQUENCY CHARACTERISTICS (DETAILS)

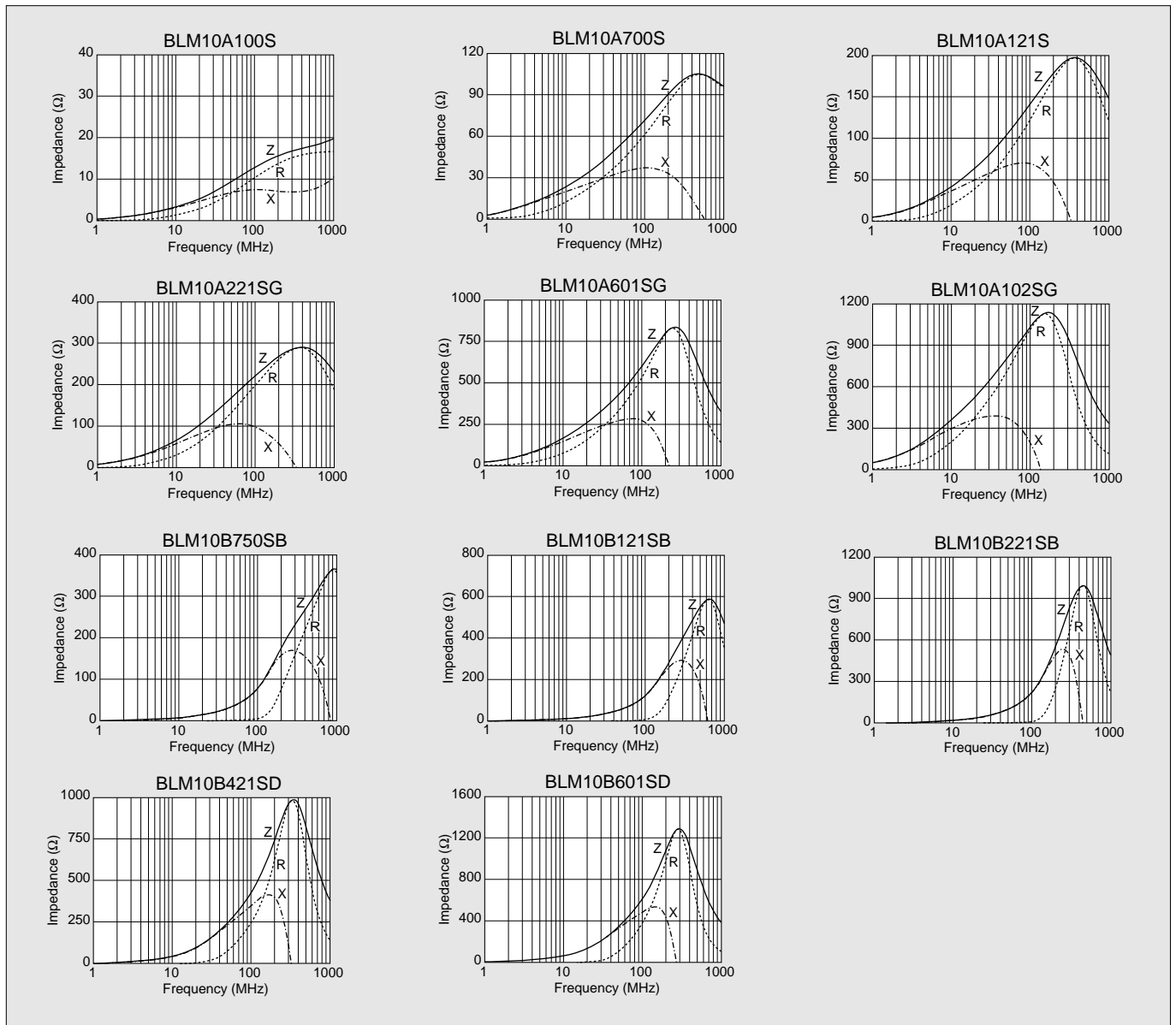

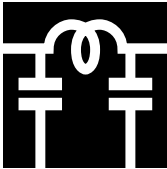

CHIP EMIFIL®

EMIFIL® is the trademark of Murata Manufacturing Co., Ltd.



Chip Ferrite Bead Inductor BLM11 Series

■ SPECIFICATIONS

Part Number	Maximum Signal Frequency (MHz)		Impedance (Ω) (Typ.) at 100MHz	Rated Current (mA)	DC Resistance (Ω max.)	Operating Temp. Range (°C)	
	*1	*2					
BLM11P300S	—	—	30	1000	0.06	-55 to +125	
BLM11P600S			60	500	0.10		
BLM11A121S			120	200	0.20		
BLM11A151SG			150		0.25		
BLM11A221S			220		0.30		
BLM11A331SG			330		0.45		
BLM11A471SG			470		0.50		
BLM11A601S			600		0.70		
BLM11A102S			1000		100		0.70
BLM11B050SB			—		500		5
BLM11B100SB	200	10		500	0.15		
BLM11B220SB	100	22			0.25		
BLM11B470SB	50	47			0.30		
BLM11B600SB	150	—	60		200		0.35
BLM11B750S	140		75	0.50			
BLM11B121SB	90		120	0.40			
BLM11B121SD	70			0.55			
BLM11B141S	80		140	0.40			
BLM11B151SB			150	0.45			
BLM11B151SD	50		220	0.75			
BLM11B221SB	60		330	0.50			
BLM11B221SD	40			0.55			
BLM11B331SB	50		420	50			1.00
BLM11B331SD	30	200		0.55			
BLM11B421S	20	470	100	0.65			
BLM11B471SB	30			600	0.85		
BLM11B471SD	20	1000	50	1.20			
BLM11B601S	15			1500	1.50		
BLM11B102S	7	—	1800	50	1.50		
BLM11B152SD			2200				
BLM11B182S			2500				
BLM11B222SD	5	—	—	—	—		
BLM11B252SD						—	

*1 has sharp impedance characteristic suitable for high speed lines. (At Maximum Signal Frequency insertion loss is 6dB in 50Ω impedance circuit.)

*2 marked items are designed for ultra-high speed signal lines such as next generation memory interface. Since these impedance curve rise from several hundred MHz, these items can suppress noise unless the misoperation of circuits. (At Maximum Signal Frequency, impedance is 22Ω which is used as Dumping.)

■ DIMENSIONS

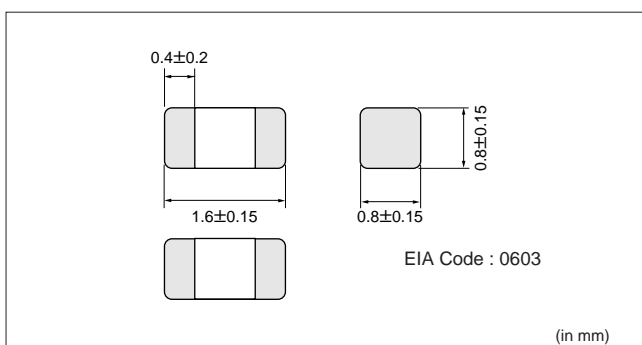

■IMPEDANCE-FREQUENCY CHARACTERISTICS (TYPICAL)

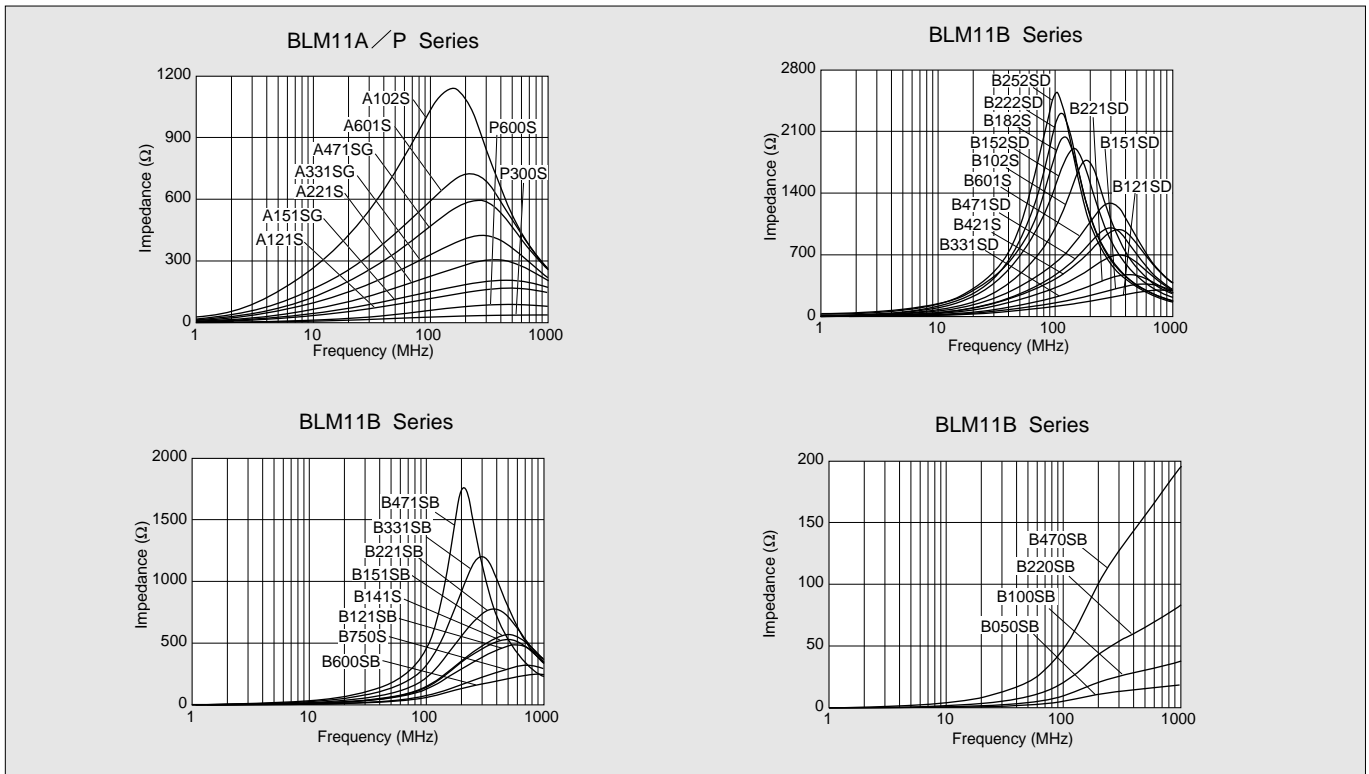

■IMPEDANCE-FREQUENCY CHARACTERISTICS (DETAILS)

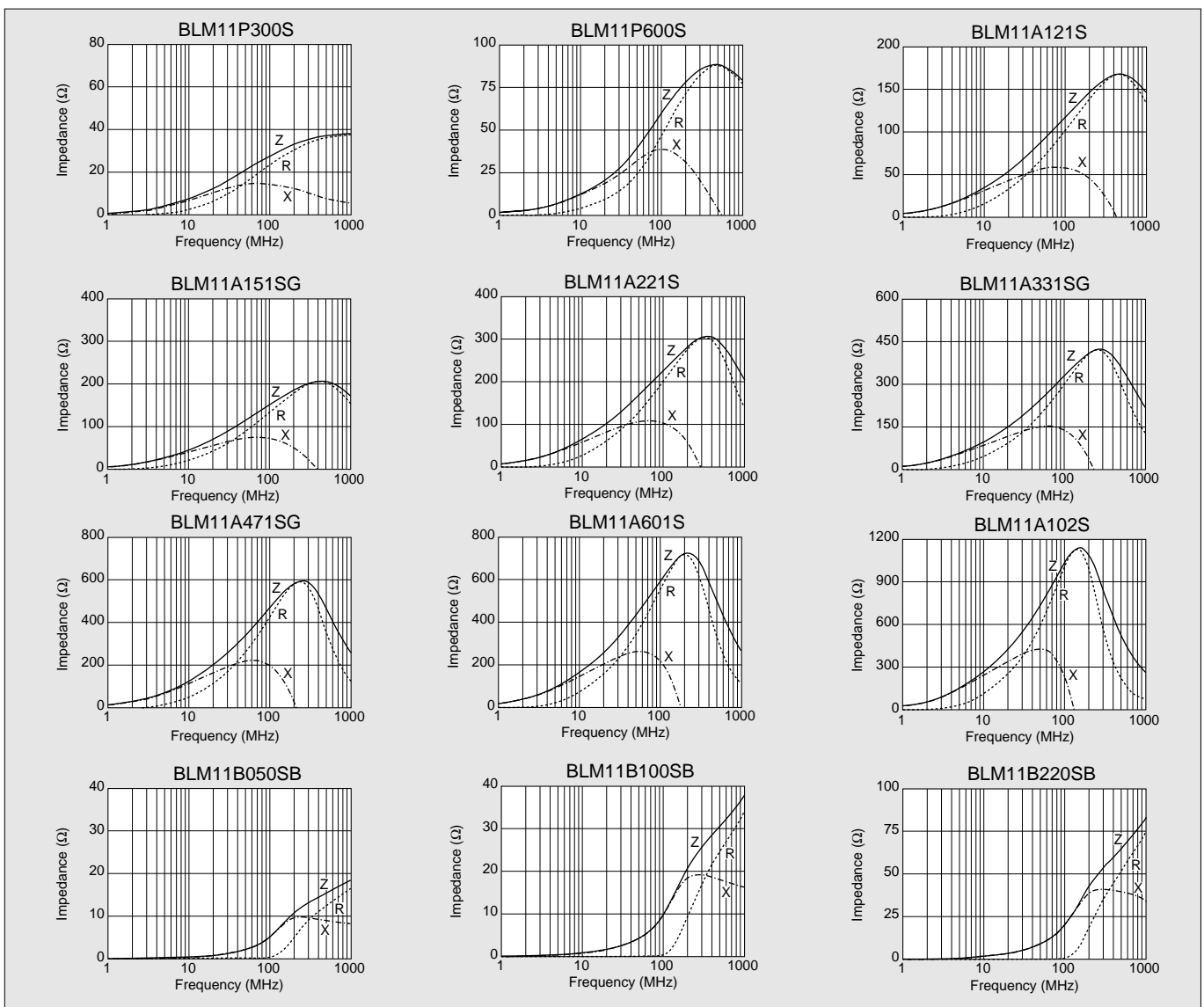

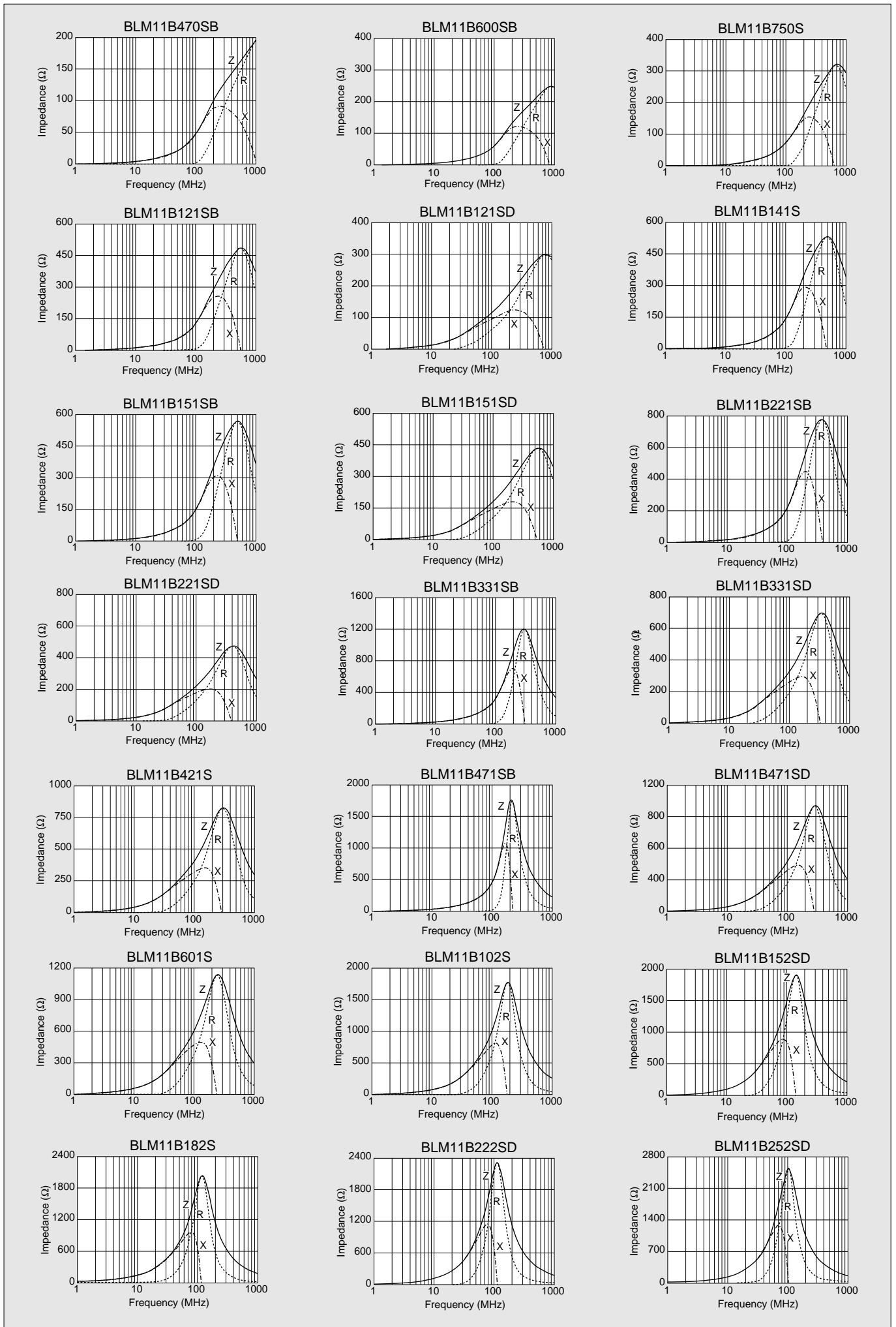

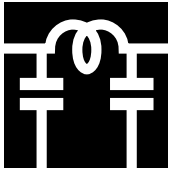

CHIP EMIFIL®

EMIFIL® is the trademark of Murata Manufacturing Co., Ltd.



Chip Ferrite Bead Inductor BLM21 Series

■ SPECIFICATIONS

Part Number	Maximum Signal Frequency (MHz)	Impedance (Ω) (Typ.) at 100MHz	Rated Current (mA)	DC Resistance (Ω max.)	Operating Temp. Range (°C)																						
BLM21P300S	—	30	3000*2	0.015	-55 to +125																						
BLM21A121F		120		200		0.40																					
BLM21A121S						150	0.15																				
BLM21A151SG							220	0.20																			
BLM21A221SG								330	0.25																		
BLM21A331SG									400	0.85																	
BLM21A401S										470	0.25																
BLM21A471SG											600	1.10															
BLM21A601F												1000	0.30														
BLM21A601S													0.45	-55 to +85													
BLM21A102F																											
BLM21A102S																											
BLM21B050S	5*1		500		0.07										-55 to +125												
BLM21B600SB	150	200	0.20																								
BLM21B750S	140		200	0.25																							
BLM21B121SB	90				120*1																						
BLM21B121SD	70					150*1																					
BLM21B151SB	80						200*1																				
BLM21B151SD	50							0.35																			
BLM21B201S	70								220*1																		
BLM21B221SB	60									0.25																	
BLM21B221SD	40										0.40																
BLM21B331SB	50											230*1															
BLM21B331SD	30												0.30														
BLM21B421S	20													420*1													
BLM21B471SB	30															470*1											
BLM21B471SD	20																600*1										
BLM21B601S																		0.35									
BLM21B751SD	15																		750*1								
BLM21B102S																				0.40							
BLM21B152SD	7																				1000*1						
BLM21B182SD																						0.45					
BLM21B222S	5																						1500*1				
BLM21B222SD																								0.50			
BLM21B222SD	1800*1																										
BLM21B222SD																									0.60		
BLM21B272S																										2200*1	
BLM21B272S																											2700*1
BLM21B272S																											

*1 has sharp impedance characteristic suitable for high speed lines.

*2 BLM21P series : Please derate the maximum current, as shown in previous page, for temperatures above +85°C.

■ DIMENSIONS

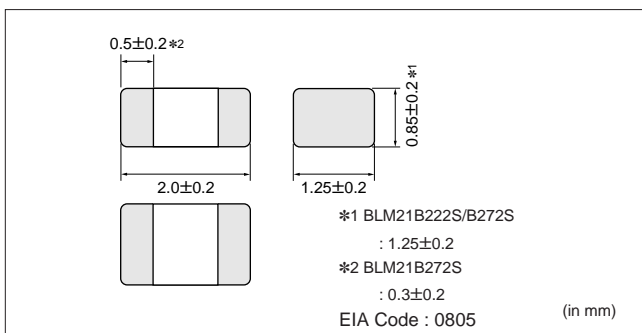

■ IMPEDANCE-FREQUENCY CHARACTERISTICS (TYPICAL)

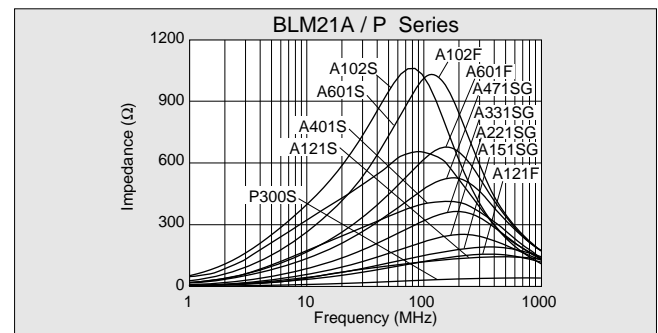

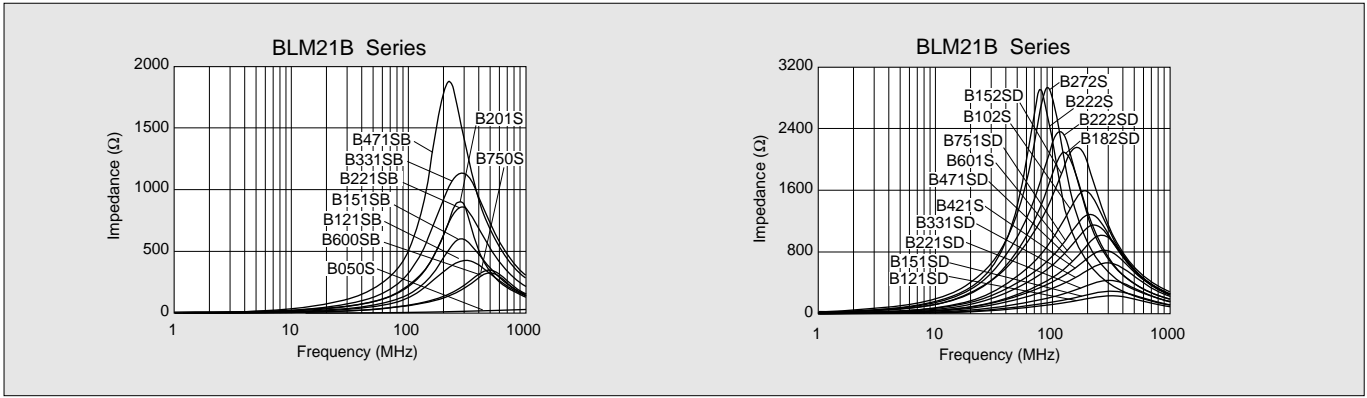

■ IMPEDANCE-FREQUENCY CHARACTERISTICS (DETAILS)

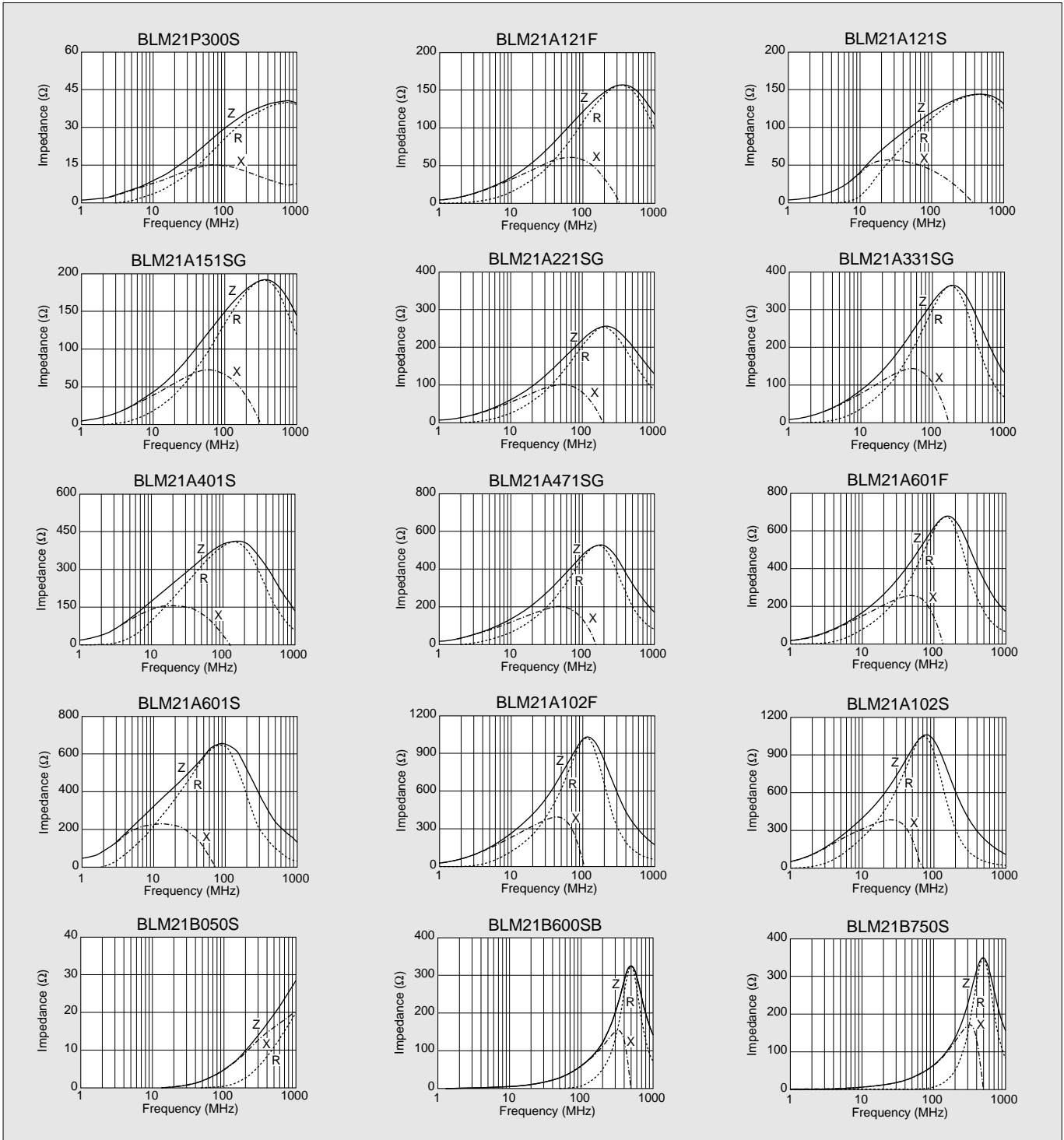

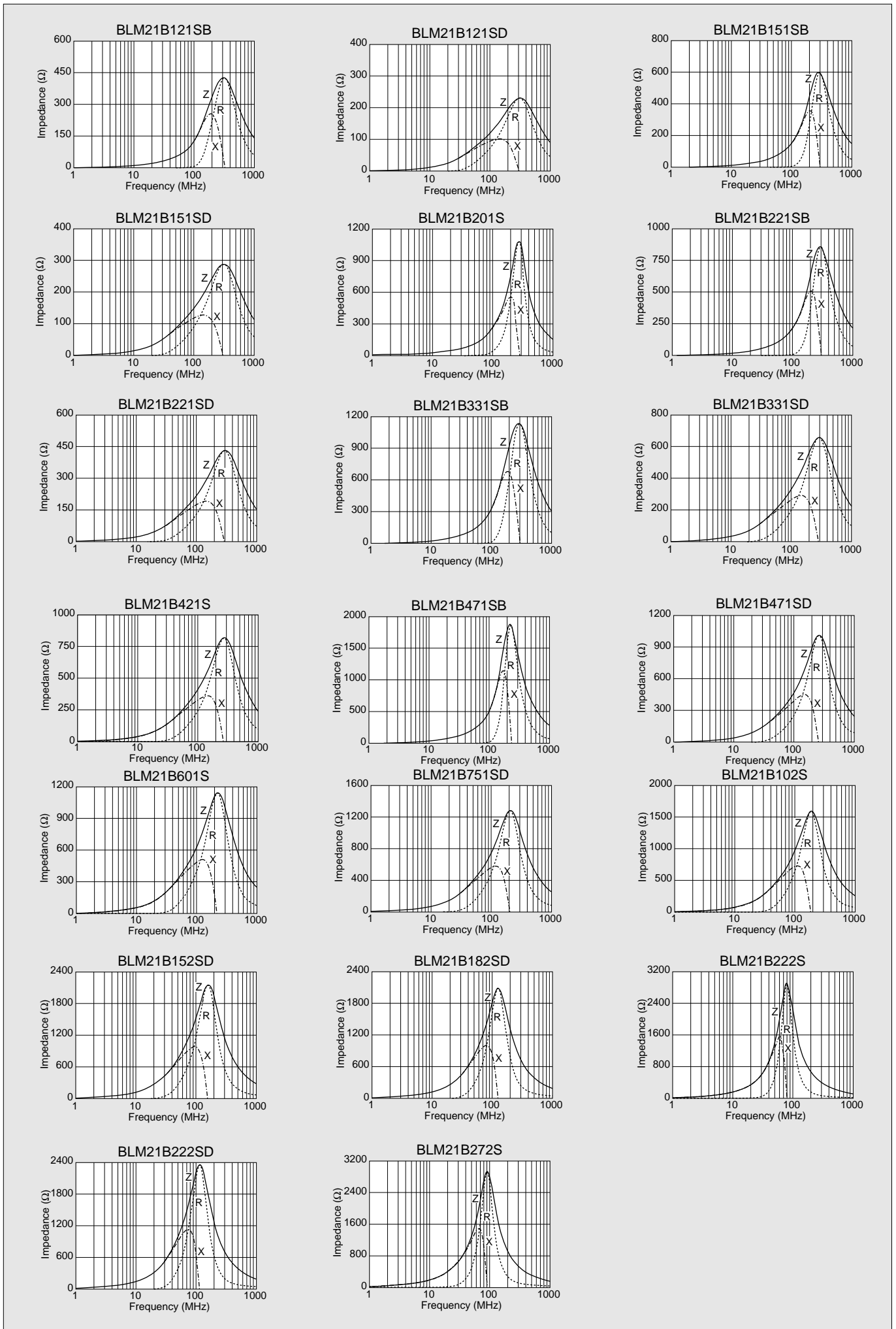

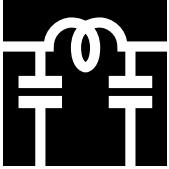

CHIP EMIFIL®

EMIFIL® is the trademark of Murata Manufacturing Co., Ltd.



Chip Ferrite Bead Inductor BLM31 Series

■ SPECIFICATIONS

Part Number	Maximum Signal Frequency (MHz)	Rated Current (mA)	DC Resistance (Ω max.)	Operating Temp. Range (°C)
BLM31P500S	50	3000 ^{*2}	0.015	-55 to +125
BLM31A260S	26	500	0.05	
BLM31A700S	70	200	0.15	
BLM31A601S	600			
BLM31B601S	600 ^{*1}	200	0.90	

*1 has sharp impedance characteristic suitable for high speed lines.

*2 BLM31P series : Please derate the maximum current, as shown in previous page, for temperatures above +85°C.

■ DIMENSIONS

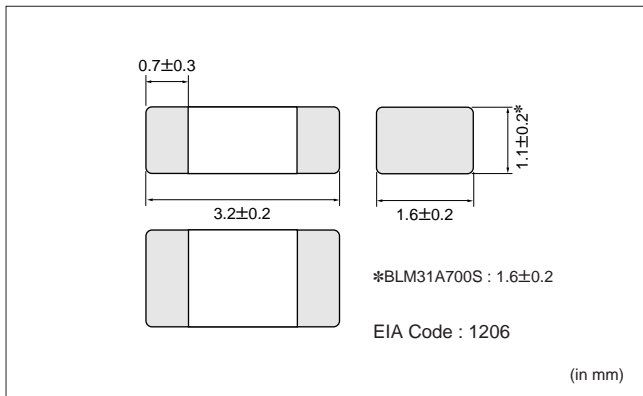

■ IMPEDANCE-FREQUENCY CHARACTERISTICS (TYPICAL)

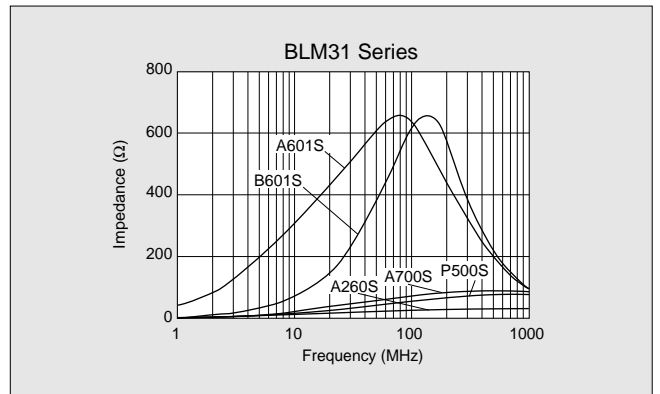

■ IMPEDANCE-FREQUENCY CHARACTERISTICS (DETAILS)

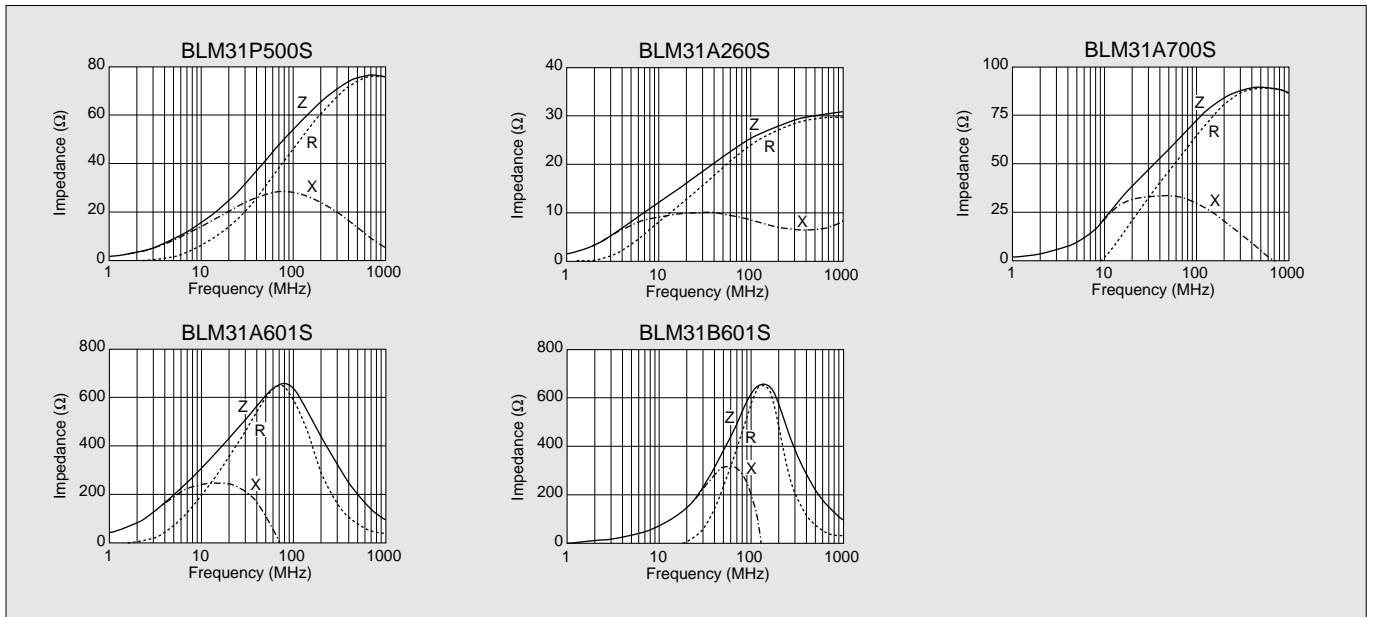

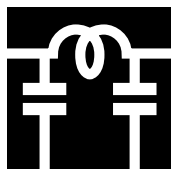

CHIP EMIFIL®

EMIFIL® is the trademark of Murata Manufacturing Co., Ltd.



Chip Ferrite Bead Inductor BLM41 Series

■ SPECIFICATIONS

Part Number	Impedance (Ω) (Typ.) at 100MHz	Rated Current (mA)	DC Resistance (Ω max.)	Operating Temp. Range (°C)
BLM41P600S	60	6000*	0.01	-55 to +125
BLM41P750S	75	3000*	0.025	
BLM41P800S	80	1000*	0.10	
BLM41A800S	80	500		
BLM41A151S	150	200	0.50	

* BLM41P series : Please derate the maximum current, as shown in previous page, for temperatures above +85°C.

■ DIMENSIONS

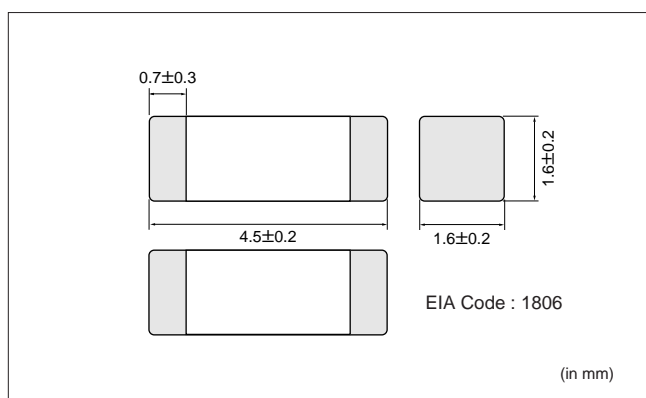

■ IMPEDANCE-FREQUENCY CHARACTERISTICS (TYPICAL)

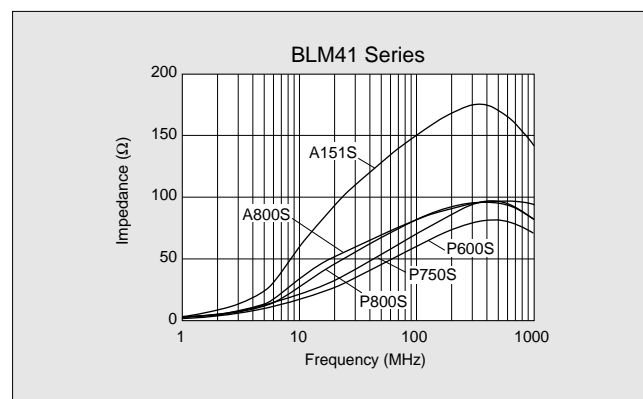

■ IMPEDANCE-FREQUENCY CHARACTERISTICS (DETAILS)

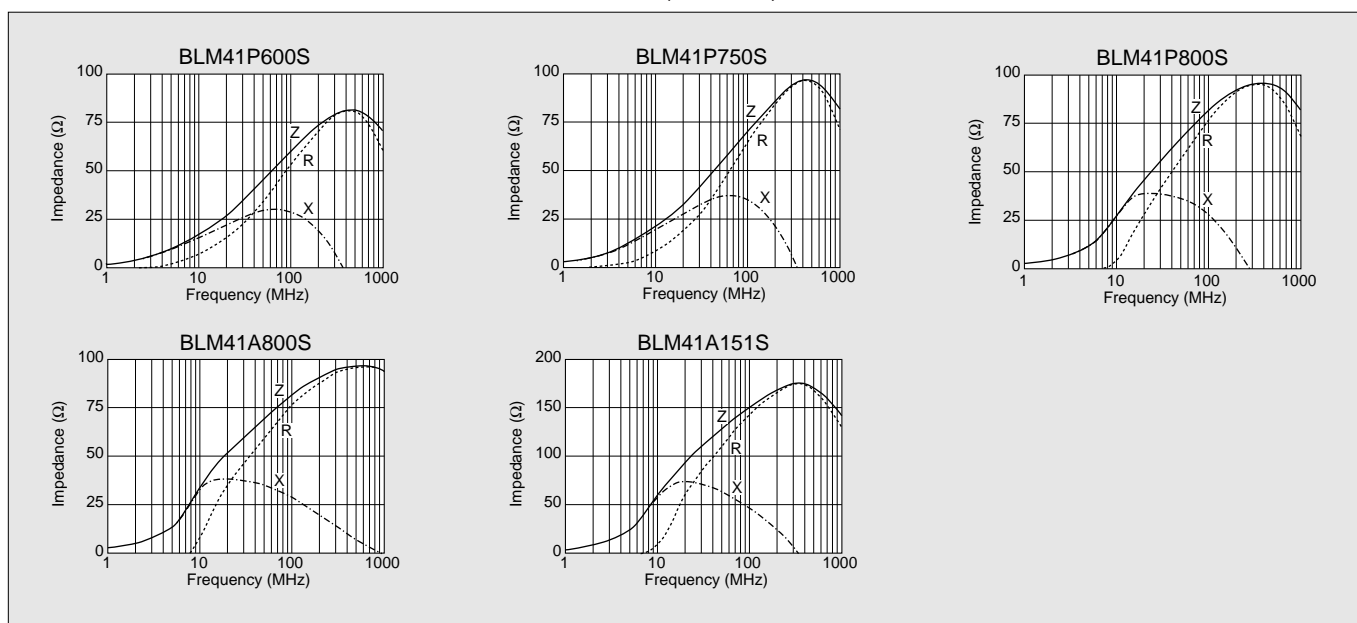

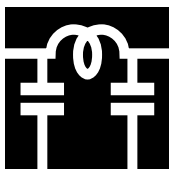

CHIP EMIFIL®

EMIFIL® is the trademark of Murata Manufacturing Co., Ltd.



Chip Ferrite Bead Array BLA3216 Series

4 Slines are Included in 3.2X1.6mm Chip

The miniaturize of electronic equipment requires high performance EMI filters which enables high density mounting. BLA3216 series consists of 4 circuit of ferrite bead inductor. BLA3216 is suitable for EMI suppression in smaller digital equipment.

FEATURES

1. BLA3216 have 4 circuits in 3.2x1.6mm body with 0.8mm pitch.
2. Provides attenuation across a broad frequency range.
Two types of impedance are available which meets general signal line and high speed signal line.
3. Original inner electrode structure enables extra low crosstalk.
4. The nickel barrier structure of the external electrodes provides excellent solder heat resistance. Both flow and reflow soldering methods can be employed.

APPLICATIONS

- Notebook size PC, PDA and other compact size digital equipment

PART NUMBERING

(Please specify the part number when ordering.)

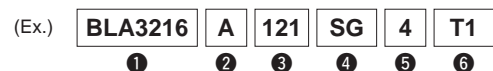

- ① Type
- ② Characteristics A : General B : High Speed
- ③ Typical Impedance at 100MHz 121 : 120Ω
- ④ Material Code
- ⑤ Number of Line
- ⑥ Packaging Code T1 : Taped B1 : Bulk package

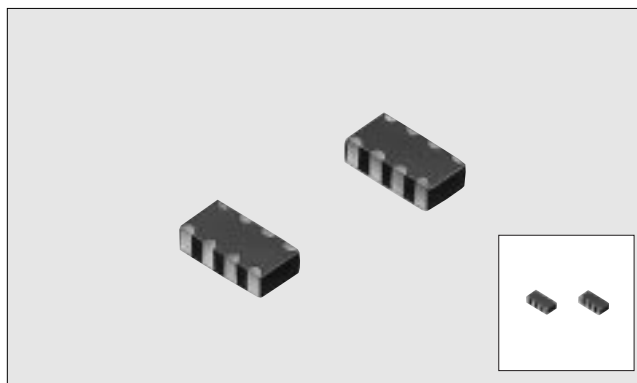

DIMENSIONS

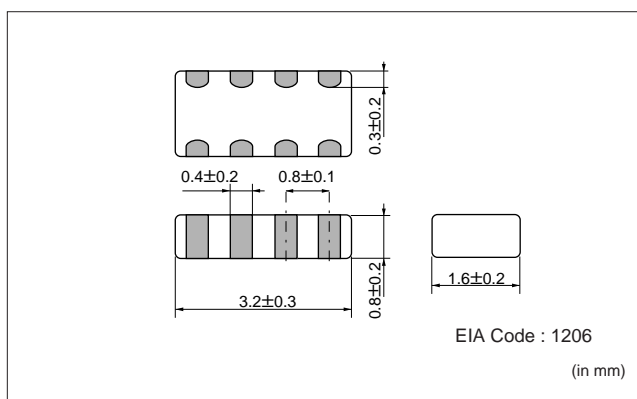

EQUIVALENT CIRCUIT DIAGRAM

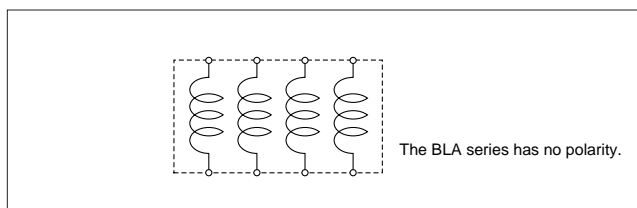

SPECIFICATIONS

Part Number	Impedance (Ω) (Typ.) at 100MHz	Rated Current (mA)	DC Resistance (Ω max.)	IR Between Element (5VDC)	Withstand Voltage Between Element	Operating Temp. Range (°C)
BLA3216A300SG4	30Ω±25%	200	0.10	100MΩmin.	100VDC	-55 to +125
BLA3216A600SG4	60Ω±25%	200	0.25			
BLA3216A121SG4	120Ω±25%	150	0.30			
BLA3216A221SG4	220Ω±25%	150	0.30			
BLA3216A601SG4	600Ω±25%	100	0.50			
BLA3216A102SG4	1000Ω±25%	50	0.70			
BLA3216B121SD4	120Ω±25%	150	0.40			
BLA3216B221SD4	220Ω±25%	150	0.45			
BLA3216B471SD4	470Ω±25%	100	0.55			
BLA3216B601SD4	600Ω±25%	100	0.65			

■IMPEDANCE-FREQUENCY CHARACTERISTICS (TYPICAL)

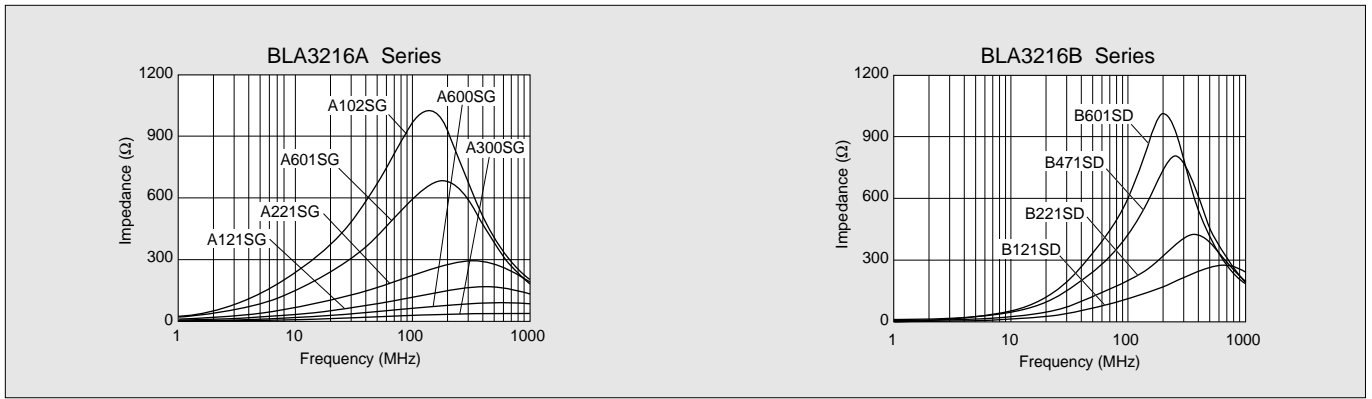

■IMPEDANCE-FREQUENCY CHARACTERISTICS (DETAILS)

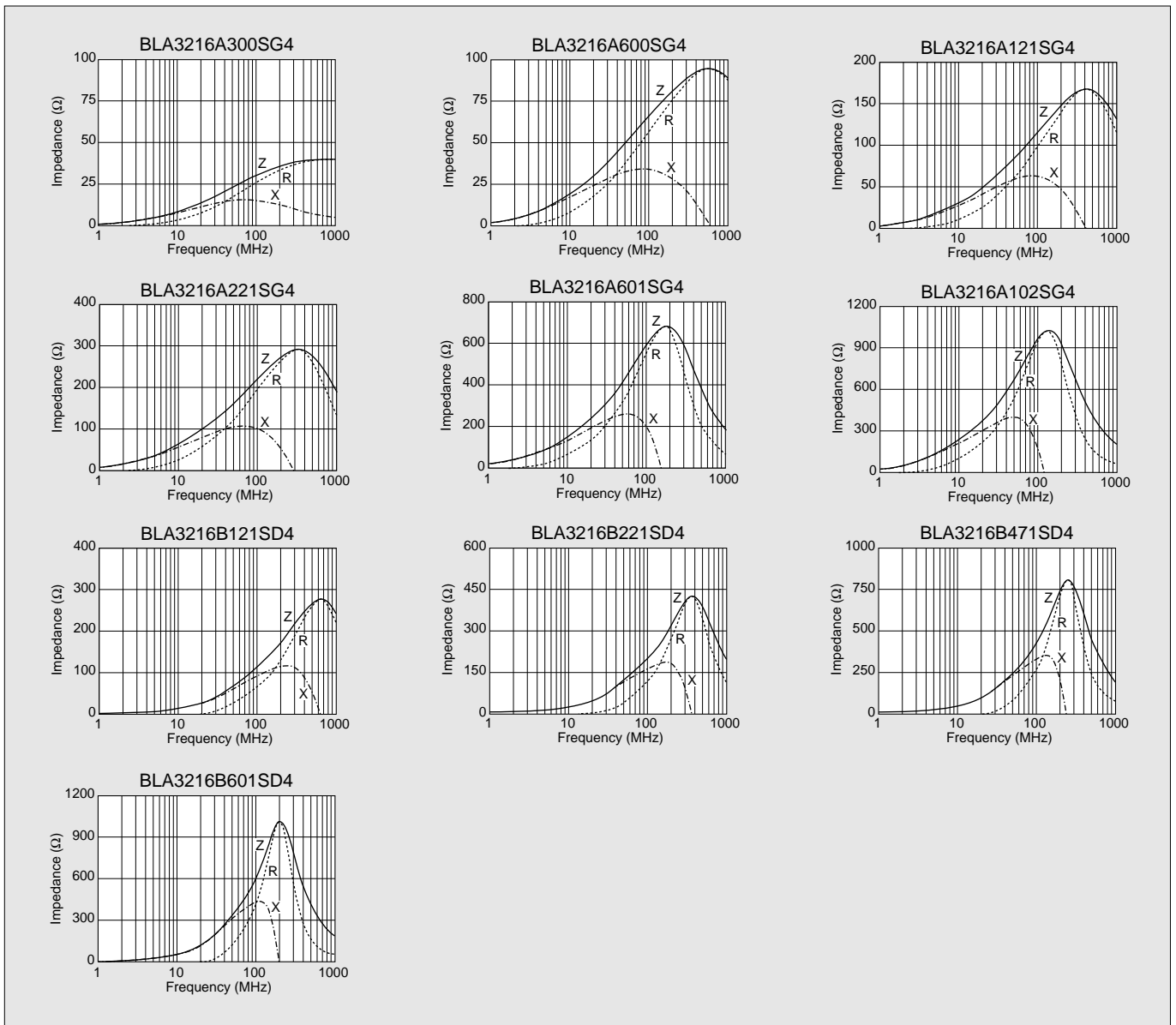

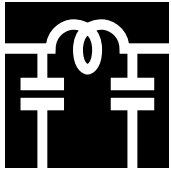

CHIP EMIFIL®

EMIFIL® is the trademark of Murata Manufacturing Co., Ltd.



Chip Ferrite Bead Inductor Array BLA41/62/81 Series

Chip Type Bead Array

(4, 6 or 8 circuits are included in one package.)

The BLA series of chip ferrite bead inductors is designed for surface mount applications. 4, 6, or 8 circuits are condensed into one package to enable significant savings in mounting space.

The inductors feature Murata's original EMI suppression technology as well as an improved design base over the single circuit type BLM series. The series is well suited for EMI suppression in digital I/O lines of varied electronic equipment such as Notebook PCs.

FEATURES

1. 4, 6, or 8 circuits are available in single packages with either 1.27mm (BLA81/41) or 0.8mm (BLA62) pitch, making the series excellent for the high density EMI suppression requirement.
2. The series can be applied to various situations by two type impedance characteristics, standard type (70Ω at 100MHz) and high-impedance type (600Ω at 100MHz).
3. The series has a unique internal structure that minimizes crosstalk.
4. The nickel barrier structure of the external electrodes provides excellent solder heat resistance.

APPLICATIONS

- Computers and peripherals, digital TVs, digital VCRs, etc.

PART NUMBERING

(Please specify the part number when ordering.)



- ① Type
- ② Number of Circuits and Terminal Pitch
 - 81....8 circuit 1.27mm pitch
 - 62....6 circuit 0.80mm pitch
 - 41....4 circuit 1.27mm pitch
- ③ Characteristics
- ④ Packaging Code T1 : Taped
 B1 : Bulk package

EQUIVALENT CIRCUIT DIAGRAM

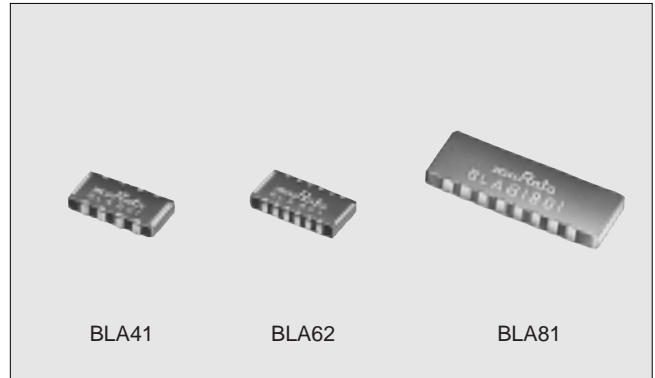
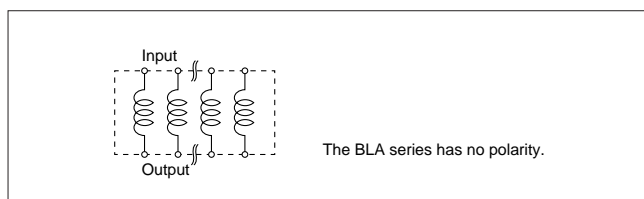

DIMENSIONS

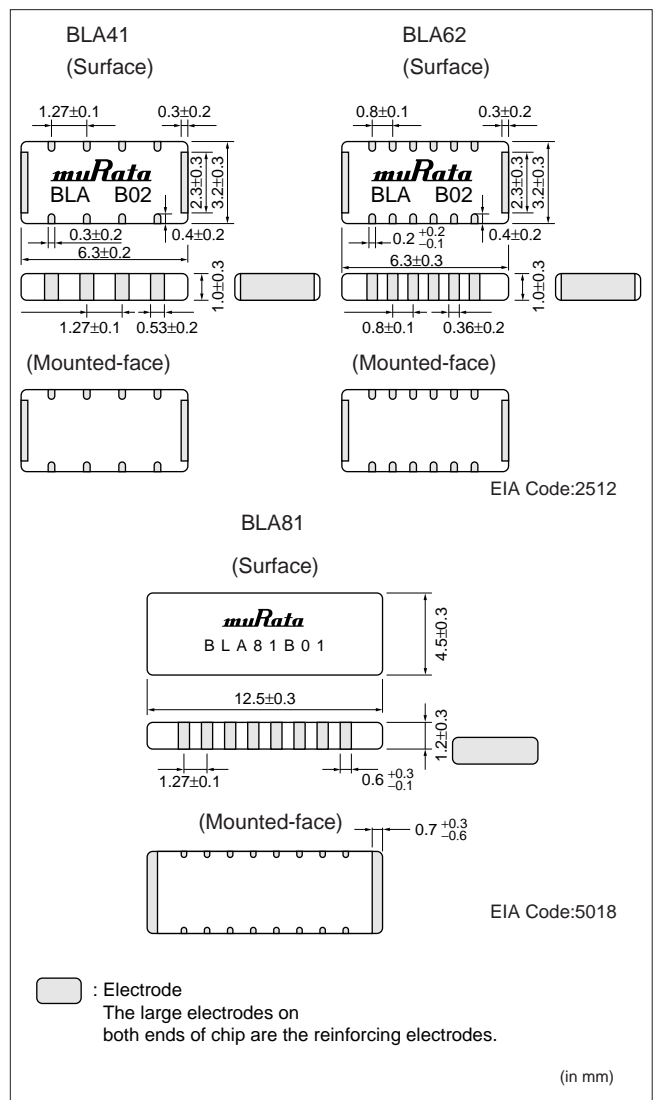

■SPECIFICATIONS

Part Number	Impedance (Ω Typ.) at 100MHz	Rated Current (mA)	Operating Temp. Range (°C)	Number of Circuits
BLA41B01	70	200	-55 to +125	4
BLA41B02	600	150*		4
BLA62B01	70	200		6
BLA62B02	600	100*		6
BLA81B01	70	300		8

*BLA41B02/BLA62B02 : Please derate the maximum current, as shown below, for temperatures above +85°C.

■IMPEDANCE-FREQUENCY CHARACTERISTICS (TYPICAL)

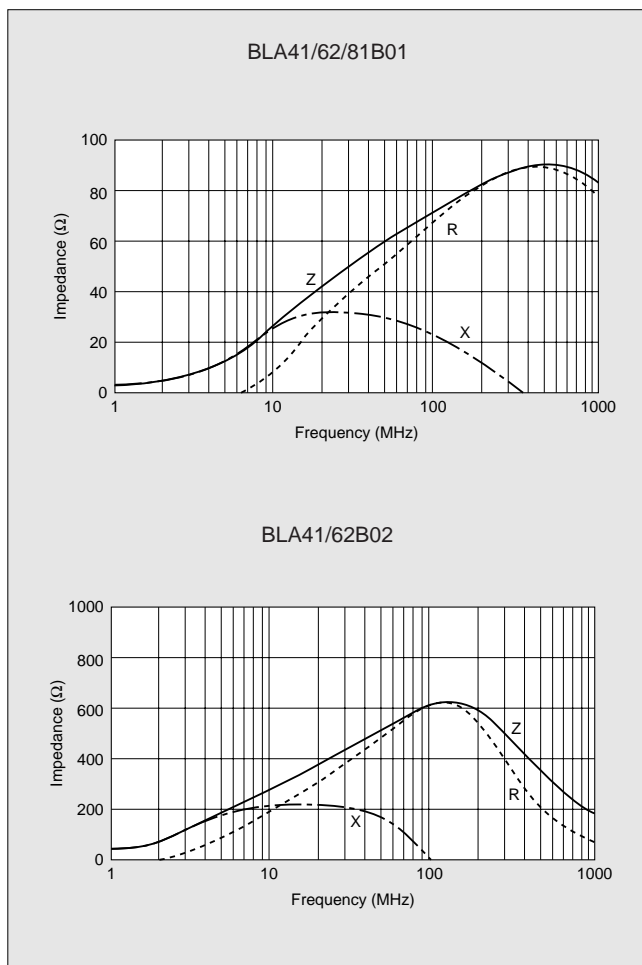

● Comparison between BLA□□B01 with BLA□□B02

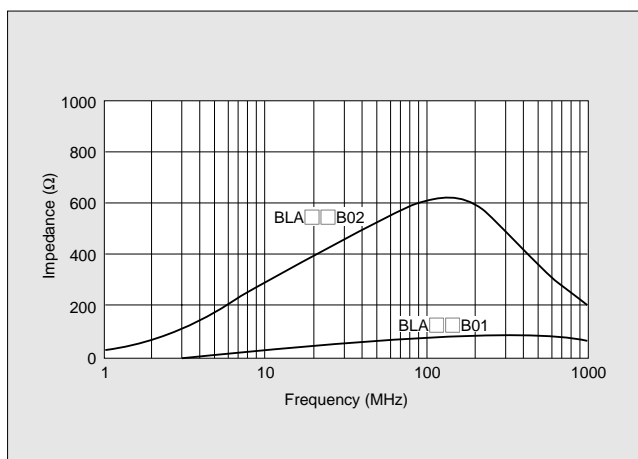

■DERATING

When the BLA41B02/BLM62B02 are used in operating temperature over 85°C, derating of current is necessary. Please apply the derating curve shown below according to the operating temperature.

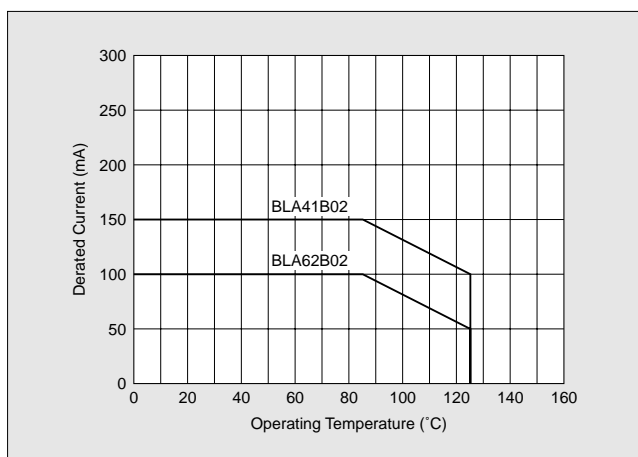

■EXAMPLE OF EMI SUPPRESSION IN PERSONAL COMPUTERS USING THE BLM SERIES

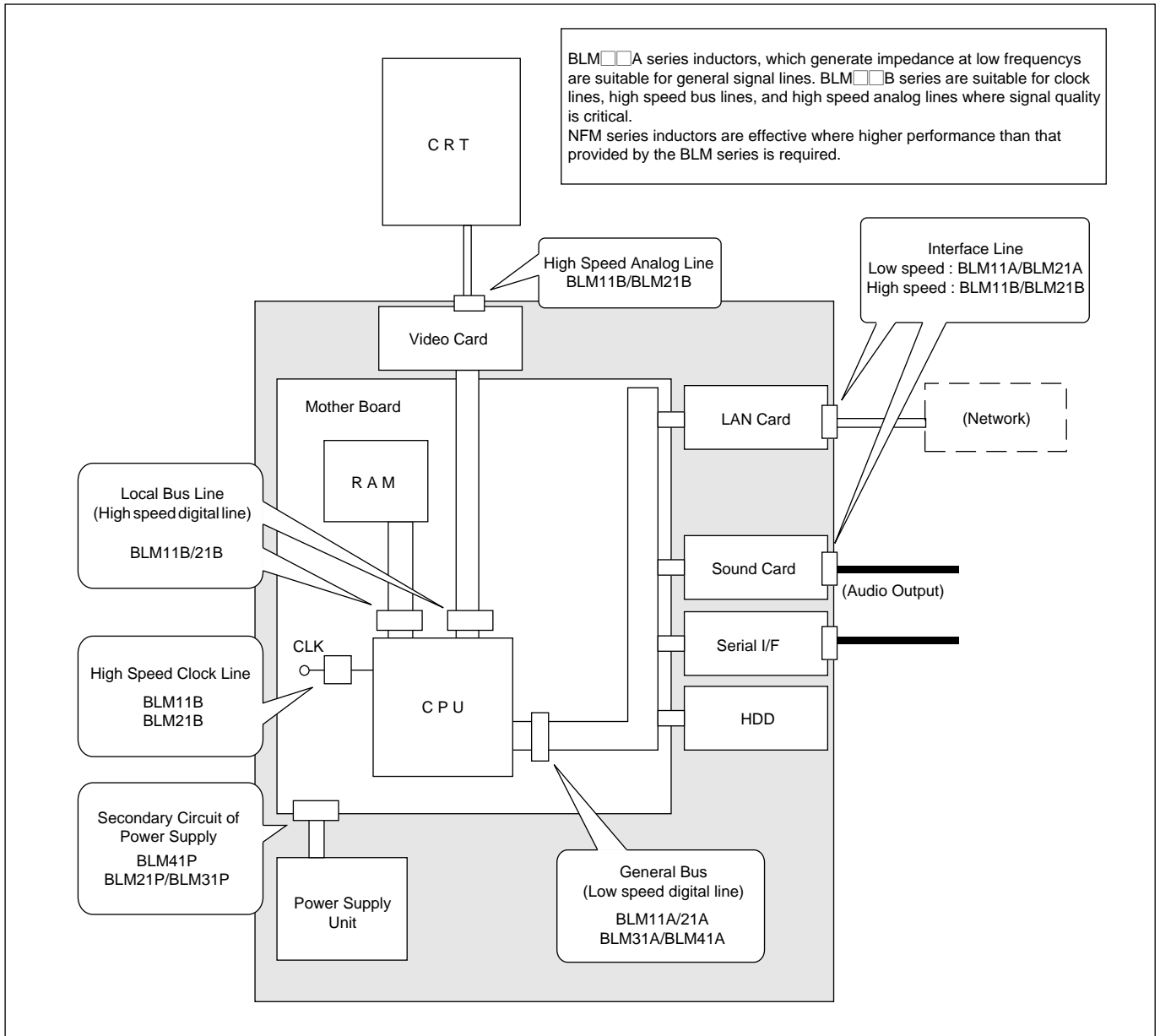

■CHIP INDUCTOR FOR CHOKE USE

There are chip inductors for choke use which are effective to suppress power line noise. Please find most suitable product in wide chip inductor for choke variation.

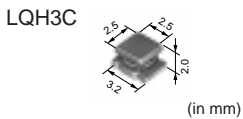

Part Number	Inductance (μH)	DC Resistance (Ω±30%)	Self-resonant Frequency (MHz min.)	Allowable Current (mA)
LQH3C○○○□34	1.0—560	0.09—22.0	5.0—96	60—800
LQH3C○○○□24	0.15—10	0.028—0.30	26—400	450—1450

● Impedance-Frequency Characteristics (Typical)

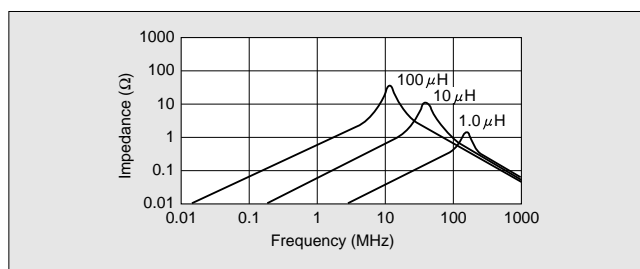

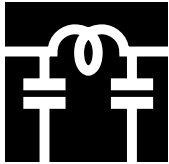

CHIP EMIFIL®

EMIFIL® is the trademark of Murata Manufacturing Co., Ltd.



Chip Solid EMIFIL® NFM39R Series

Small Size Chip 3 Terminal Capacitor which Enables Downsizing of Electrical Equipments

Chip solid EMIFIL® NFM39R is 2.0mm×1.25mm size chip 3 terminal capacitor which enables electrical equipments smaller. Equivalent capacitance range to conventional type from 22pF up to 22000pF is available in spite of its small shape.

FEATURES

1. Small and low profile of 2.0mm×1.25mm×0.5mm enables high density mounting.
2. The 3 terminal structure enables high performance in high frequency range.
3. Use original electrode structure which realize excellent solderability.

APPLICATIONS

- PCs and peripherals which emit high amount of noise
- Compact size equipment such as PDA, PC card and mobile telecommunication equipments

PART NUMBERING

(Please specify the part number when ordering)

(Ex.)

NFM39R	02	C	220	T1
①	②	③	④	⑤

① Type

② Class No.

③ Circuit Composition

④ Characteristics

⑤ Packaging Code T1 : Taped

B1 : Bulk package

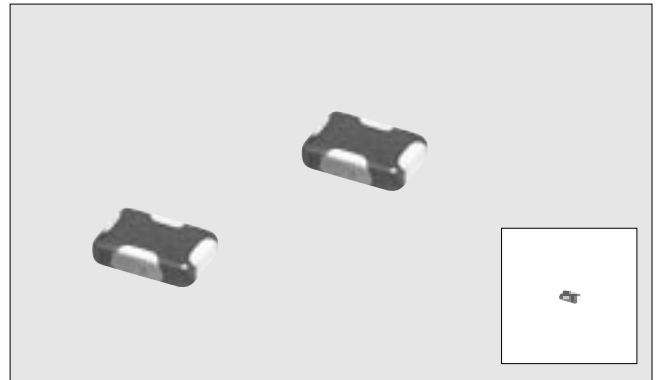

DIMENSIONS

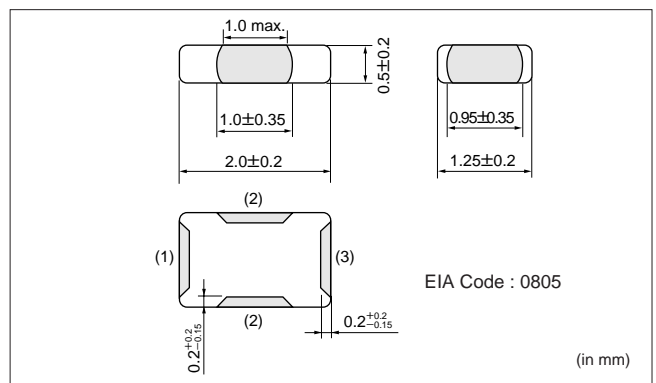

EQUIVALENT CIRCUIT DIAGRAM

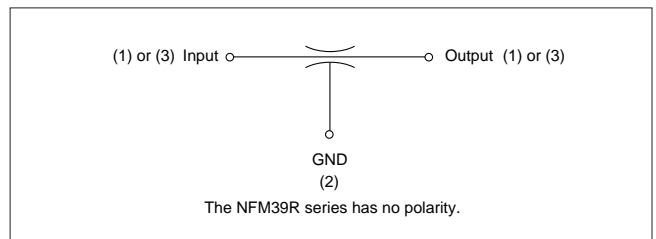

■SPECIFICATIONS

Part Number	Capacitance	Rated Voltage	Rated Current	Insulation Resistance	DC Resistance	Operating Temp. Range
NFM39R02C220	22pF±20%	50VDC	300mADC	1000MΩ min.	0.6Ω max.	-55°C to +125°C
NFM39R02C470	47pF±20%					
NFM39R02C101	100pF±20%					
NFM39R12C221	220pF±20%					
NFM39R12C471	470pF±20%					
NFM39R12C102	1000pF±20%					
NFM39R12C222	2200pF±20%					
NFM39R12C223	22000pF±20%					

■INSERTION LOSS CHARACTERISTICS (TYPICAL)

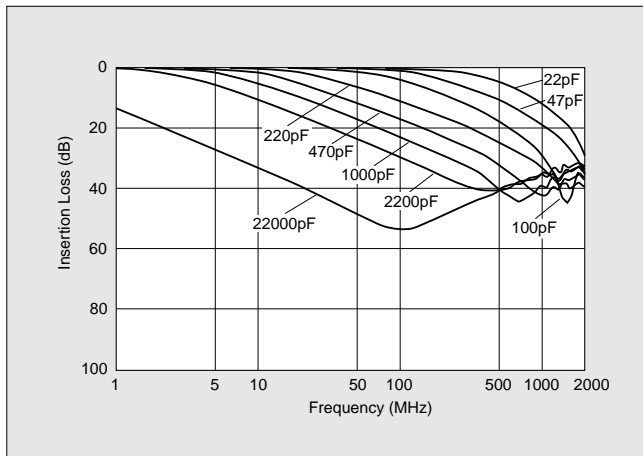

■INSERTION LOSS MEASURING CIRCUIT

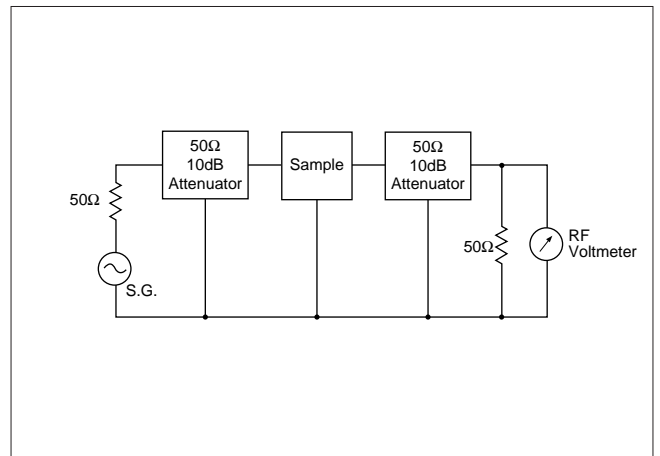

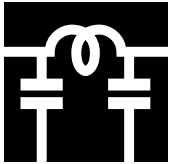

CHIP EMIFIL[®]

EMIFIL[®] is the trademark of Murata Manufacturing Co., Ltd.



Chip Solid EMIFIL[®] NFM40R/NFM41R Series

The chip solid EMIFIL[®] NFM40R/NFM41R series is a chip type 3-terminal EMI suppression filter. It can reduce residual inductance to an extremely low level making it excellent for noise suppression at high frequencies. An electrostatic capacitance range of 22pF to 22000pF enables suppression of noise at specific frequencies. (The array type NFA series is also available.)

FEATURES

1. The series is compact and thin : t=0.7mm and 1.0mm.
2. The filter offers a high level of noise suppression.
3. The filter has excellent high-frequency characteristics.

APPLICATIONS

- EMI suppression in various electronic equipment
- EMI suppression of AC signal lines and DC power lines
- Severe EMI suppression and high impedance circuits such as digital circuits

PART NUMBERING

(Please specify the part number when ordering)

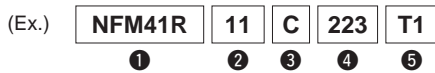

- ① Type
- ② Class No.
- ③ Circuit Composition
- ④ Characteristics
- ⑤ Packaging Code T1 : Taped
 B1 : Bulk package

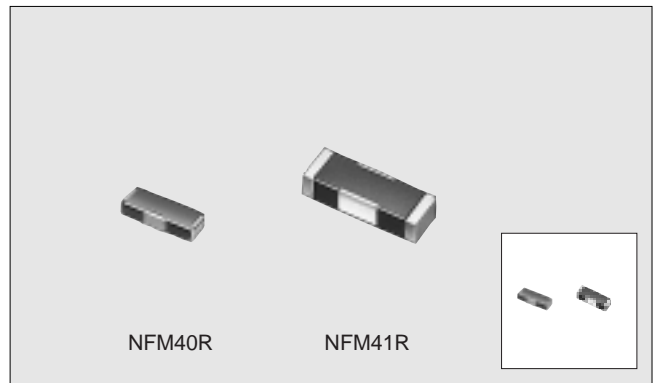

DIMENSIONS

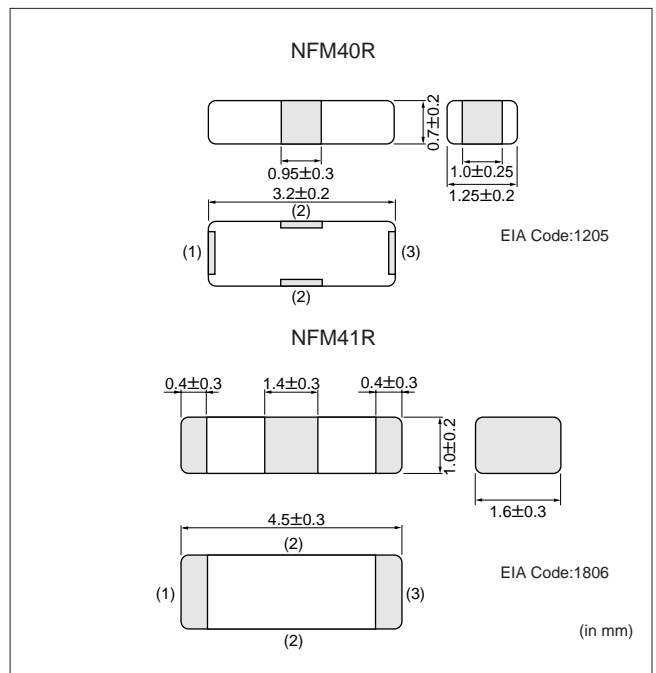

EQUIVALENT CIRCUIT DIAGRAM

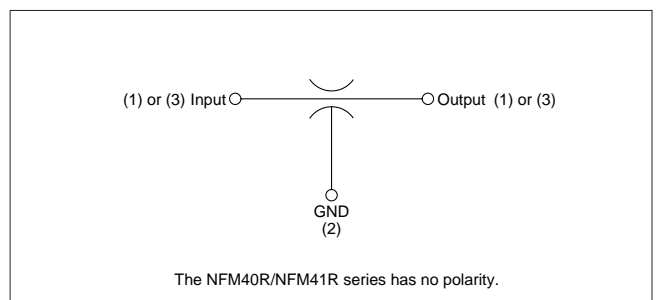

■SPECIFICATIONS

NFM40R Series

Part Number	Capacitance	Rated Voltage	Rated Current	Insulation Resistance	DC Resistance	Operating Temp. Range
NFM40R01C220	22pF ^{+50%} _{-20%}	25VDC	300mADC	1000MΩmin.	0.6Ωmax.	-55°C to +125°C
NFM40R01C470	47pF ^{+50%} _{-20%}					
NFM40R01C101	100pF ^{+50%} _{-20%}					
NFM40R11C221	220pF ^{+50%} _{-20%}					
NFM40R11C471	470pF ^{+50%} _{-20%}					
NFM40R11C102	1000pF ^{+50%} _{-20%}					
NFM40R11C222	2200pF ^{+50%} _{-20%}					-55°C to +85°C
NFM40R11C223	22000pF ^{+80%} _{-20%}					

NFM41R Series

Part Number	Capacitance	Rated Voltage	Rated Current	Insulation Resistance	DC Resistance	Operating Temp. Range
NFM41R01C220	22pF ^{+50%} _{-20%}	100VDC	300mADC	10000MΩmin.	0.3Ωmax.	-55°C to +125°C
NFM41R01C470	47pF ^{+50%} _{-20%}					
NFM41R01C101	100pF ^{+50%} _{-20%}					
NFM41R01C221	220pF ^{+50%} _{-20%}					
NFM41R01C471	470pF ^{+50%} _{-20%}					
NFM41R11C102	1000pF ^{+50%} _{-20%}					
NFM41R11C222	2200pF ^{+50%} _{-20%}					
NFM41R11C223	22000pF ^{+50%} _{-20%}					

■INSERTION LOSS CHARACTERISTICS (TYPICAL)

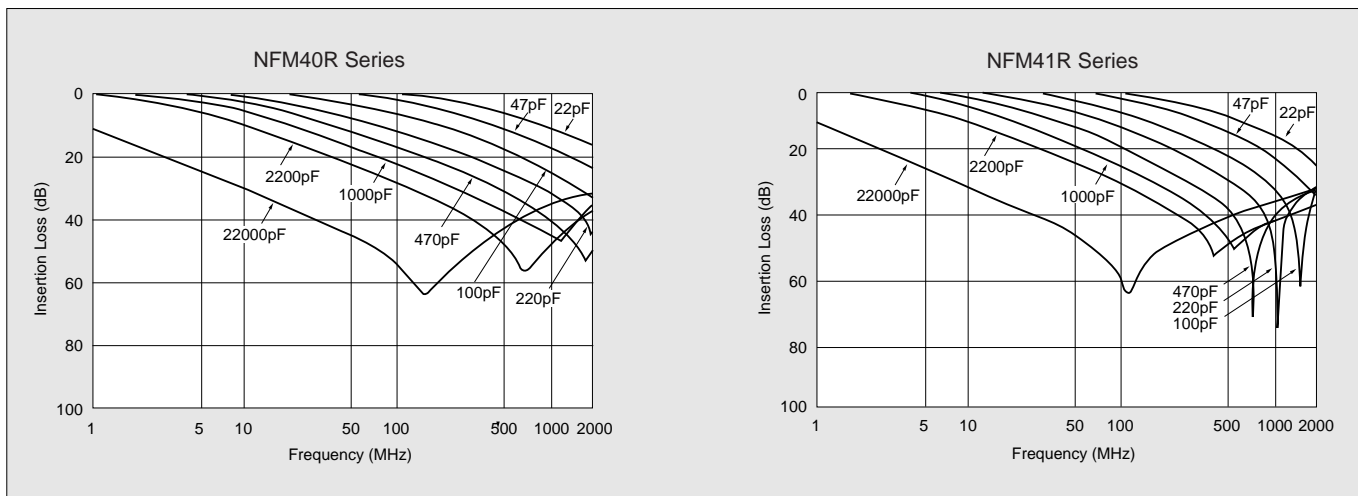

■INSERTION LOSS MEASURING CIRCUIT

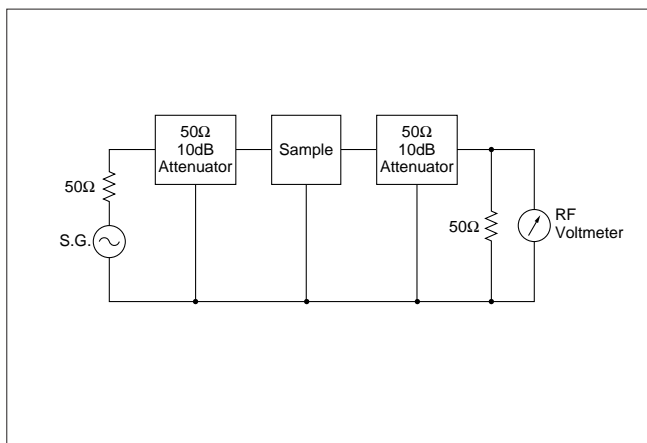

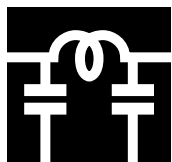

CHIP EMIFIL®

EMIFIL® is the trademark of Murata Manufacturing Co., Ltd.



Chip Solid EMIFIL® Array NFA81R/62R/41R Series

Reduces Mounting Space of 67%*

The NFA series of chip EMI suppression filters is designed for surface mount applications. 4, 6, or 8 circuits are condensed into one package to enable significant savings in mounting space. The filters feature Murata's original EMI suppression technology as well as an improved design base over the single circuit type NFM41R series. The series is well suited for EMI suppression in digital I/O lines of varied electronic equipment such as Notebook PCs.

*When NFA62R is used, compared with NFM41R.

FEATURES

1. 4, 6, or 8 circuits are available in single packages with either 0.8mm (NFA62R) or 1.27mm (NFA81R/41R) pitch, making the series excellent for the high density EMI suppression requirement. For example, a space saving of 67% can be realized when using the NFA62R instead of the NFM41R.
2. The 3-terminal structure realizes excellent EMI suppression at high frequencies. The series has a unique internal structure that minimizes crosstalk.
3. The filter has two ground terminals to provide perfect ground conditions for all filter circuits. In this way, excellent EMI suppression in a narrow path can be realized using uncomplicated land designs.
4. The nickel barrier structure of the external electrodes provides excellent solder heat resistance. Both flow and reflow soldering techniques are possible.
5. The series is available in a wide variety of capacitances to meet many of your noise suppression requirements.

APPLICATIONS

- Computers and peripherals, digital TVs, digital VCRs etc.

PART NUMBERING

(Please specify the part Number when ordering.)



- ① Type
- ② Number of Circuits and Terminal Pitch
 - 81....8 circuit 1.27mm pitch
 - 62....6 circuit 0.80mm pitch
 - 41....4 circuit 1.27mm pitch
- ③ Monolithic type
- ④ Class No.
- ⑤ Circuit Composition
- ⑥ Characteristics
- ⑦ Packaging Code T1 : Taped
 B1 : Bulk package

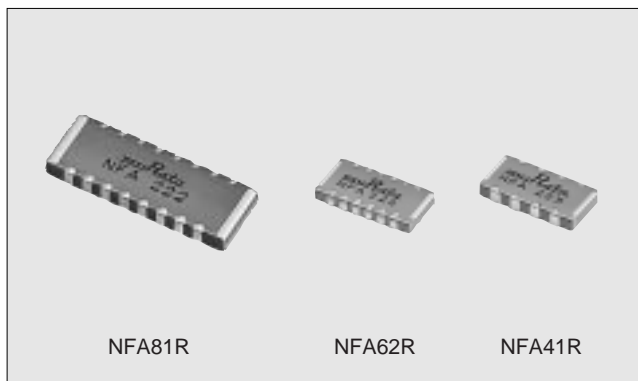

DIMENSIONS

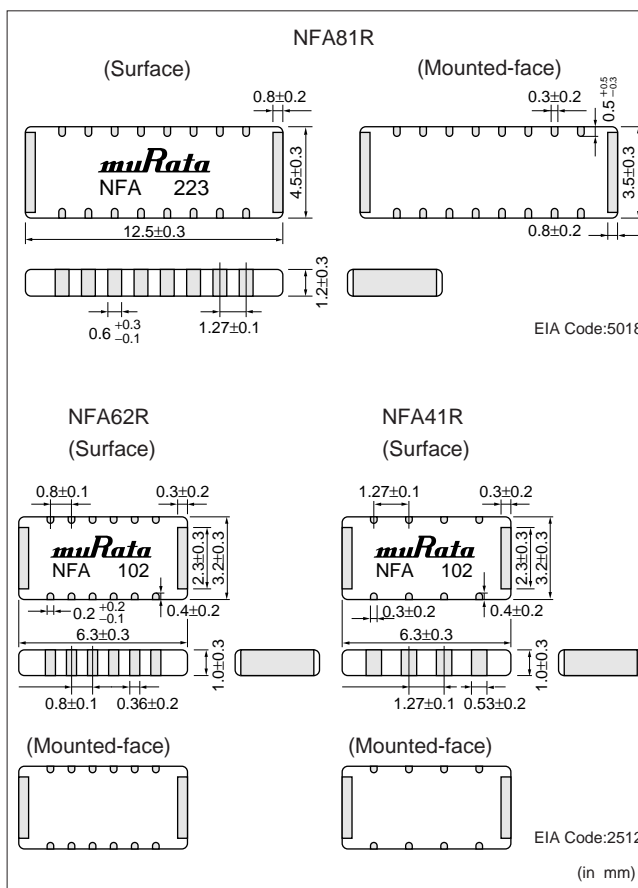

EQUIVALENT CIRCUIT DIAGRAM

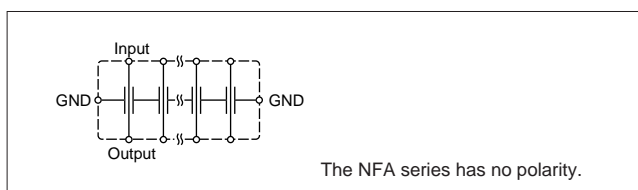

■ SPECIFICATIONS

Part Number	Capacitance	Rated Voltage	Rated Current	Insulation Resistance	Operating Temp. Range	Number of Circuit
NFA81R00C220	22pF ^{+50%} _{-20%}	50VDC	300mADC	1000MΩmin.	-55°C to +125°C	8
NFA81R00C470	47pF ^{+50%} _{-20%}					
NFA81R00C101	100pF ^{+50%} _{-20%}					
NFA81R00C221	220pF ^{+50%} _{-20%}					
NFA81R00C471	470pF ^{+50%} _{-20%}		200mADC			
NFA81R10C102	1000pF ^{+50%} _{-20%}					
NFA81R10C222	2200pF ^{+50%} _{-20%}					
NFA81R10C223	22000pF ^{+50%} _{-20%}					
NFA62R00C220	22pF ^{+50%} _{-20%}	50VDC	200mADC	1000MΩmin.	-55°C to +85°C	6
NFA62R00C470	47pF ^{+50%} _{-20%}					
NFA62R00C101	100pF ^{+50%} _{-20%}					
NFA62R00C221	220pF ^{+50%} _{-20%}					
NFA62R00C471	470pF ^{+50%} _{-20%}					
NFA62R00C102	1000pF ^{+50%} _{-20%}					
NFA62R10C222	2200pF ^{+50%} _{-20%}					
NFA62R10C223	22000pF ^{+50%} _{-20%}					
NFA41R00C220	22pF ^{+50%} _{-20%}	50VDC	200mADC	1000MΩmin.	-55°C to +85°C	4
NFA41R00C470	47pF ^{+50%} _{-20%}					
NFA41R00C101	100pF ^{+50%} _{-20%}					
NFA41R00C221	220pF ^{+50%} _{-20%}					
NFA41R00C471	470pF ^{+50%} _{-20%}					
NFA41R10C102	1000pF ^{+50%} _{-20%}					
NFA41R10C222	2200pF ^{+50%} _{-20%}					
NFA41R10C223	22000pF ^{+50%} _{-20%}					
NFA41R10C104	100000pF ^{+80%} _{-20%}					

■ INSERTION LOSS CHARACTERISTICS (TYPICAL)

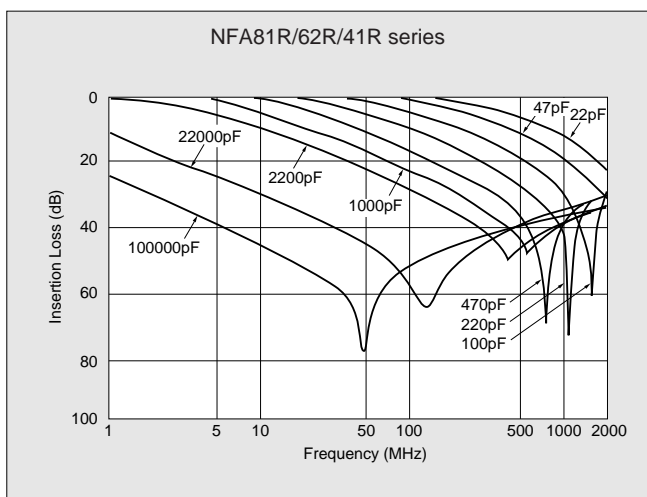

■ INSERTION LOSS MEASURING CIRCUIT

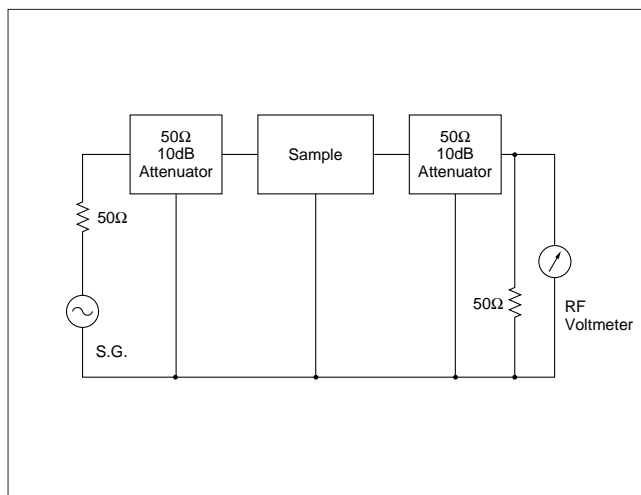

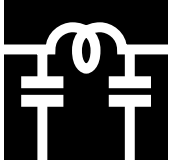

CHIP EMIFIL®

EMIFIL® is the trademark of Murata Manufacturing Co., Ltd.



Chip EMIFIL® NFM839R Series

Distributed Constant Circuit Type Chip EMIFIL® which Prevent Wave Distortion

Chip EMIFIL®NFM839R series is a high performance and small shape EMI suppression filter which can suppress distortion of the waveform. The NFM839R series can be used in interface lines and clock lines where signals tend to be distorted. Two types of cut off frequency (20MHz, 50MHz) are available for both high impedance lines and low impedance lines.

■FEATURES

1. MURATA's original inner design realized small and low profile of 2.0mm X 1.25mm X 0.5mm.
2. Distributed constant circuit realizes smooth change of impedance which prevents reflection of signal and distortion of wave shape.
3. The NFM839R series is effective in the line in which ground is not stable because the resistance element in the filter absorb noise and return it to ground line.
4. The NFM839R series has no polarity so that it can be used in dual direction transport lines.

■APPLICATIONS

- Suppression of noise in interface line or clock line of digital equipment (such as personal computers, word processors)

■PART NUMBERING

(Please specify the part number when ordering.)

(Ex.)	NFM839R	02	C	100	R	220	T1
	①	②	③	④	⑤	⑥	⑦

- ① Type
- ② Class No.
- ③ Current Composition
- ④ Capacitance
- ⑤ Class No.
- ⑥ Resistance
- ⑦ Packaging Code

T1 : Taped
B1 : Bulk package

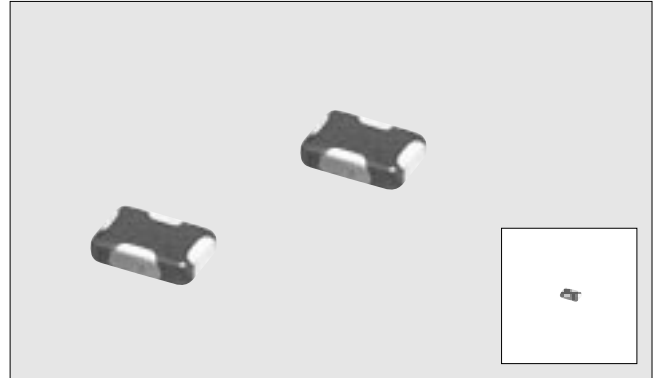

■DIMENSIONS

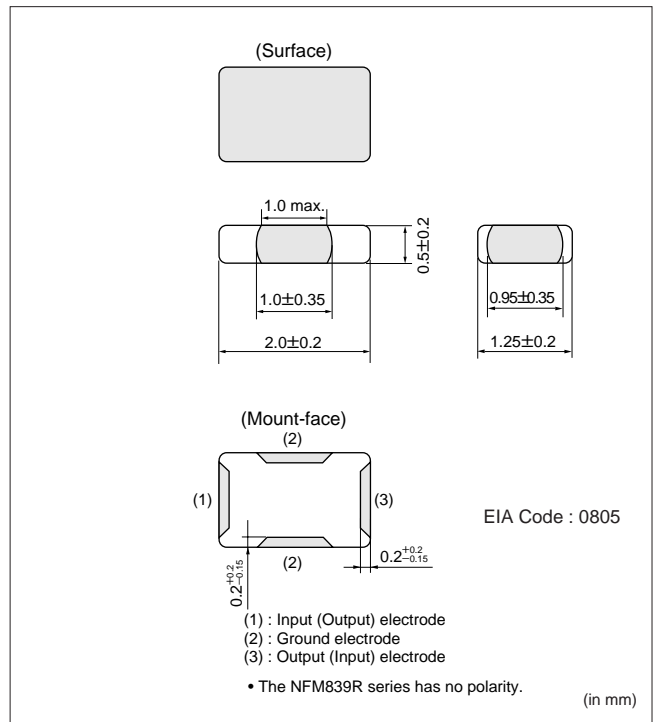

■EQUIVALENT CIRCUIT DIAGRAM

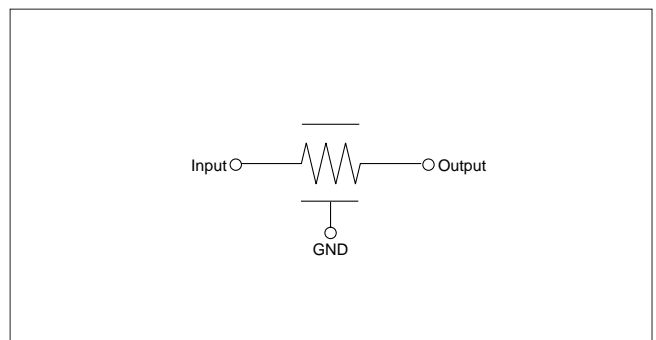

■ SPECIFICATIONS

Part Number	Capcittance (pF)	Resistance (Ω)	Rated Current (mA) (1)–(3)	Rated Voltage (VDC) (1)(3)–(2)	Insulation Resistance (MΩ) (1)(3)–(2)	Operating Temp. Range (°C)
NEW NFM839R02C100R220	10±20%	122±30%	50	50	1000min.	-40 to +85
NEW NFM839R02C100R470		147±30%	35			
NEW NFM839R02C470R220	47±20%	122±30%	50			
NFM839R02C470R470		147±30%	35			
NEW NFM839R02C470R680		168±30%	30			
NFM839R02C470R101		100±30%	25			
NEW NFM839R02C101R220	100±20%	122±30%	50			
NFM839R02C101R470		147±30%	35			
NEW NFM839R02C101R680		168±30%	30			
NFM839R02C101R101		100±30%	25			

■ INSERTION LOSS CHARACTERISTICS (TYPICAL)

• For High Impedance Line (Measured with 50Ω-3kΩ lines)

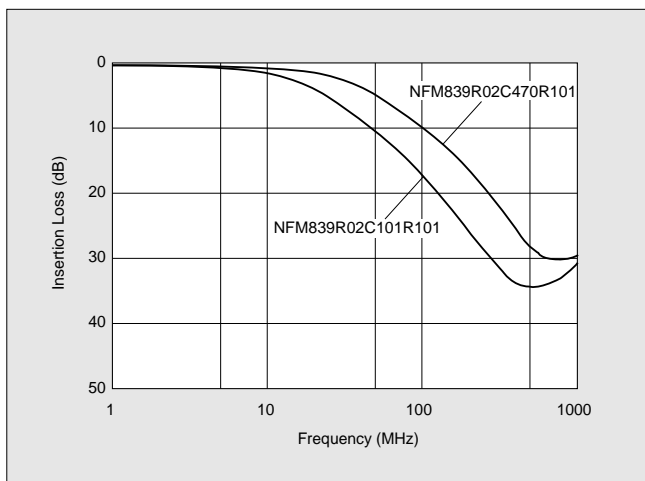

• For Low Impedance Line (Measured with 50Ω-150Ω lines)

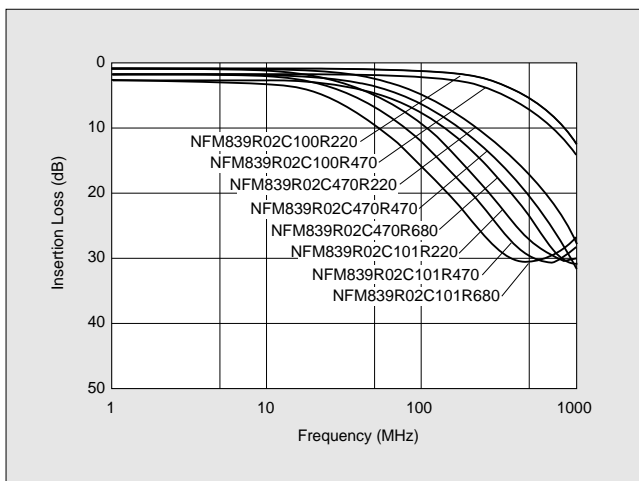

■ INSERTION LOSS MEASURING CIRCUITS

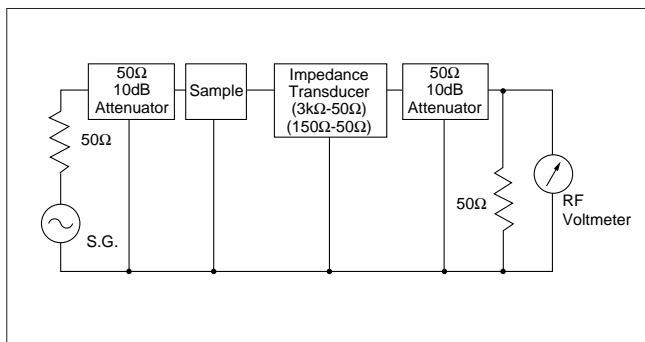

EFFECT OF NOISE SUPPRESSION BY NFM839R

The NFM839R is effective even if ground line is not stable enough due to its distribute constant circuit structure.

TESTING CIRCUIT

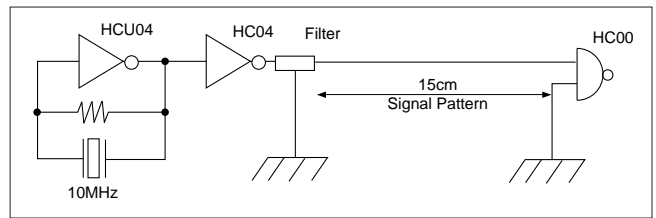

With Stable Ground Line

● Noise Level without Filter

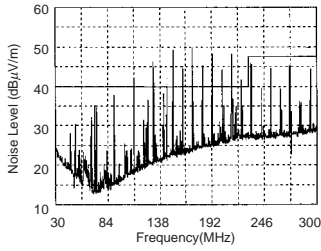

● Filter Mounting Condition

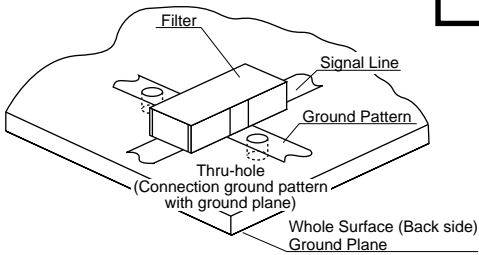

Standard Type Chip EMIFIL[®]
(100pF)

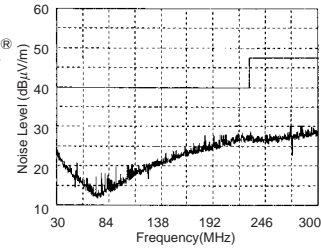

The standard type chip EMIFIL[®] is effective on stable ground line.

NFM839R02C470R101

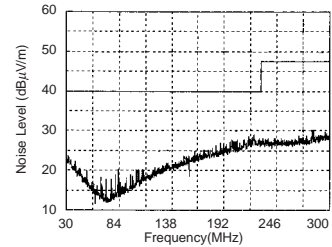

The NFM839R has some advantage to standard type EMIFIL[®] on stable ground line.

With Poor Ground Line

● Noise Level without Filter

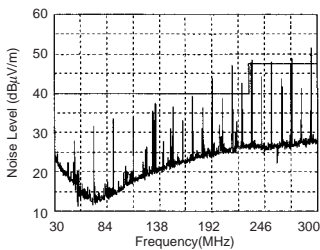

● Filter Mounting Condition

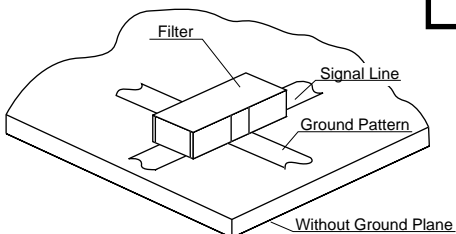

Standard Type ChipEMIFIL[®]
(100pF)

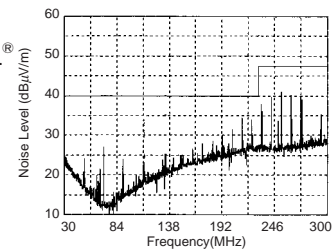

The standard type EMIFIL[®] lose efficiency on poor ground line.

NFM839R02C470R101

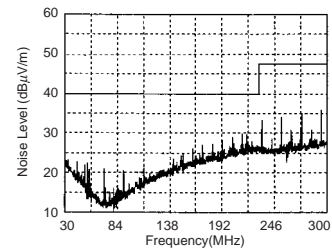

The NFM839R is effective even on poor ground line because of its distribute constant circuit structure and unique system to limit rush current.

■ WAVEFORM DISTORTION SUPPRESSING FUNCTION BY NFM839R

● Testing Circuit

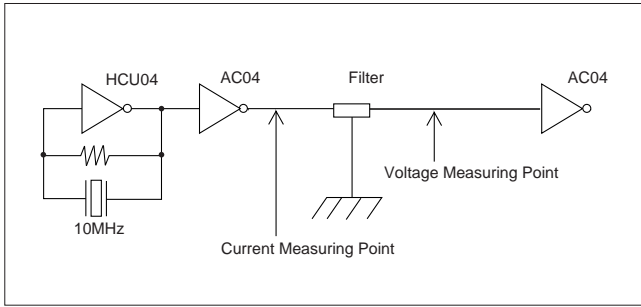

Initial Waveform (no filter)

● Voltage Waveform

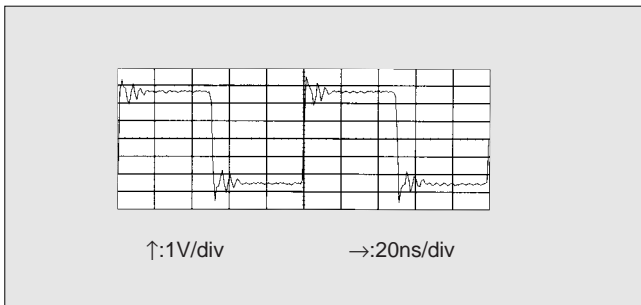

Resonance between the internal capacitance of the IC and the inductance of the print pattern causes waveform overshooting and undershooting.

● Current Waveform

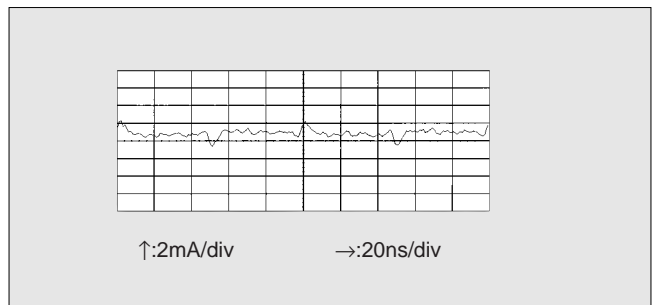

When Ordinary Capacitor Filter is Used

● Output Voltage Waveform

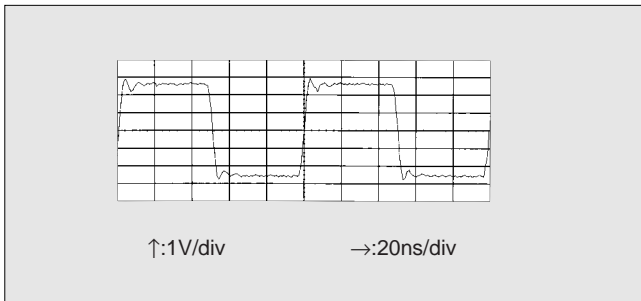

Ordinary capacitor filters have no waveform distortion suppressing capability, and they cannot suppress disturbances in the waveforms.

● Input Current Waveform

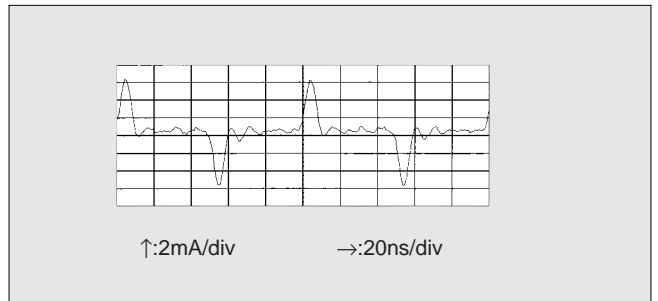

The current needed to charge and discharge the capacitor raises the peak level of current that flows out of the driver side IC, increasing the load on the IC.

NFM839R

● Output Voltage Waveform

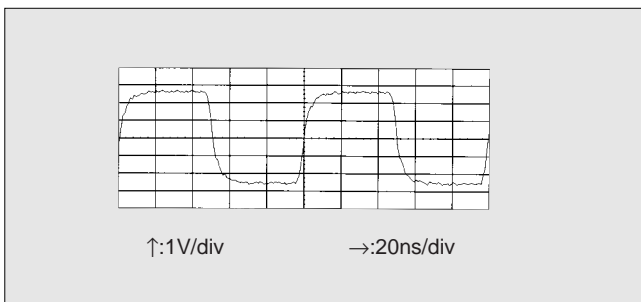

The waveform distortion suppressing function of the NFM839R minimizes disturbances of waveforms.

● Input Current Waveform

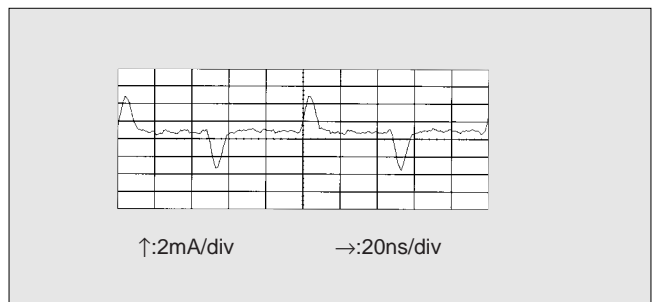

The NFM839R also includes a current limiting function, reducing the load on driver ICs.

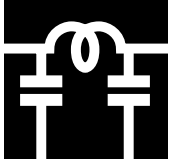

CHIP EMIFIL®

EMIFIL® is the trademark of Murata Manufacturing Co., Ltd.



Chip EMI Suppression Filter(EMIFIL®)for Signal Line NFM51R Series

The signal line chip EMIFL® NFM51R series consist of high performance EMI suppression filters. They are designed for noise suppression in high speed digital circuits in which the signal harmonics are prone to becoming noise sources. These filters achieve a 100dB/dec. (typ.) damping characteristic made possible by Murata's innovative circuit design. This makes these chips effective in applications where the signal and noise frequencies are close to each other.

FEATURES

1. The filters suppress signal noise with little or no attenuation of the signal itself.
2. Murata's original internal structure design enables excellent noise suppression up to high frequencies (40dB at 1GHz typ.).
3. The NFM51R series is available in six different values of cutoff frequency ranging from 10MHz up to 500MHz.

APPLICATIONS

- Suppression of high magnitude radiated noise generated by high speed digital circuits such as clock and RGB circuits
- Suppression of noise in high speed processing circuits such as digital image signal processing circuits

PART NUMBERING

(Please specify the part number when ordering.)



- ① Type
- ② Class No.
- ③ Cut-off Frequencies

SPECIFICATIONS

Part Number	Cut-off Frequency (MHz)	Attenuation (dB min.)							Rated Voltage (VDC)	Rated Current (mA)	Operating Temp. Range
		10MHz	20MHz	50MHz	100MHz	200MHz	500MHz	1GHz			
NFM51R00P106	10	*	5	25	25	25	30	30	25	200	-40°C to +85°C
NFM51R00P206	20	—	*	5	25	25	30	30			
NFM51R00P506	50	—	—	*	10	30	30	30			
NFM51R10P107	100	—	—	—	*	5	20	30			
NFM51R20P207	200	—	—	—	—	*	10	30			
NFM51R30P507	500	—	—	—	—	—	*	10			

*6dB max.

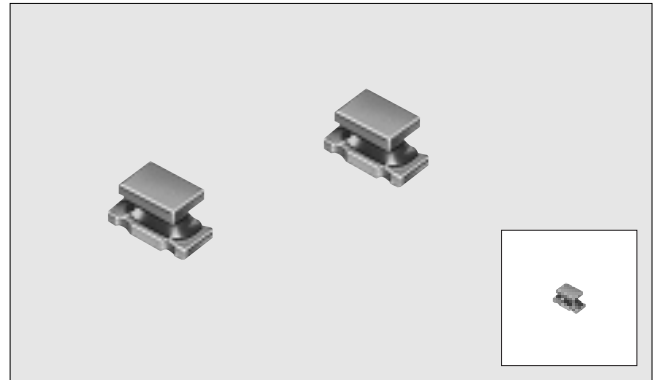

DIMENSIONS

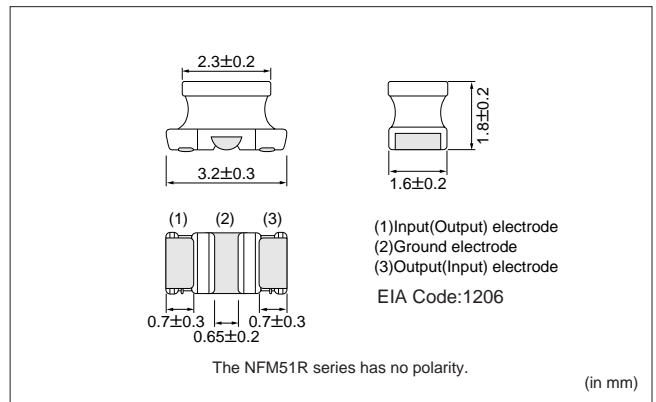

■ INSERTION LOSS CHARACTERISTICS (TYPICAL)

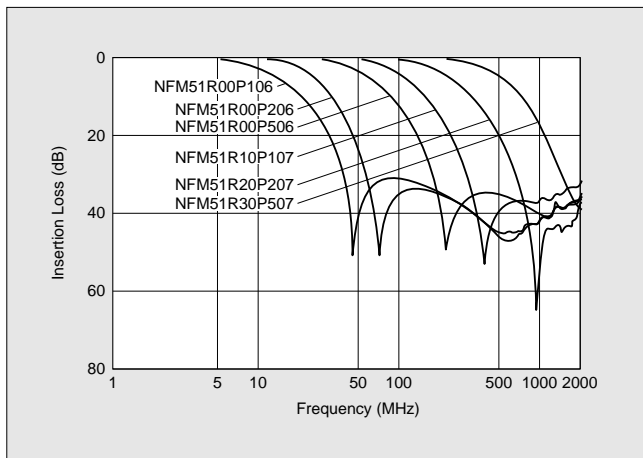

■ INSERTION LOSS MEASURING CIRCUIT

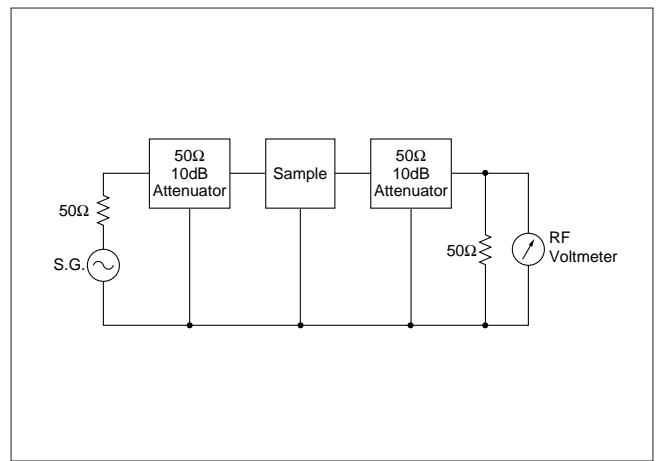

● **Comparison with Conventional Chip EMIFIL®**

NFM51R series can realize EMI suppression without reducing effective elements of the signal, because it has steep attenuation characteristics.

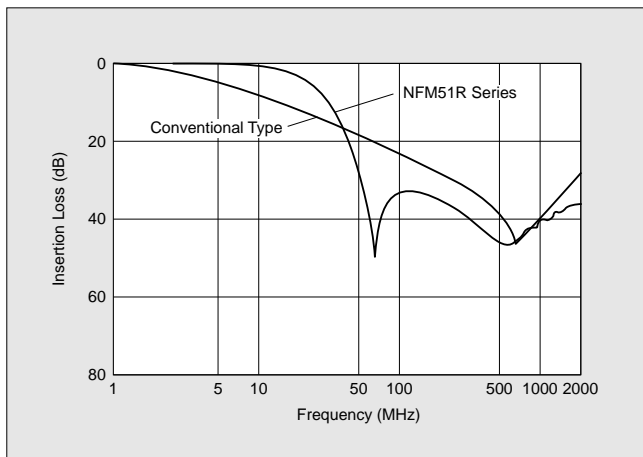

EXAMPLE OF EMI SUPPRESSION IN AN ACTUAL CIRCUIT

Measuring Circuit

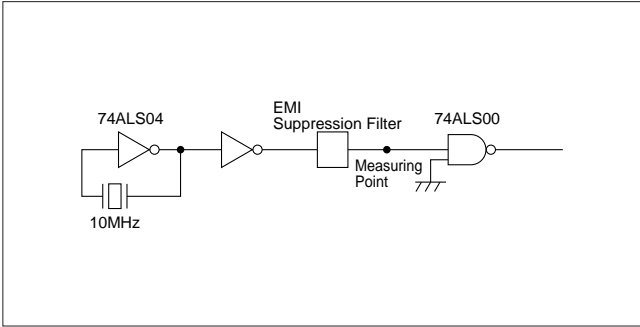

Signal Waveform and Noise Spectrum before Filter Mounting

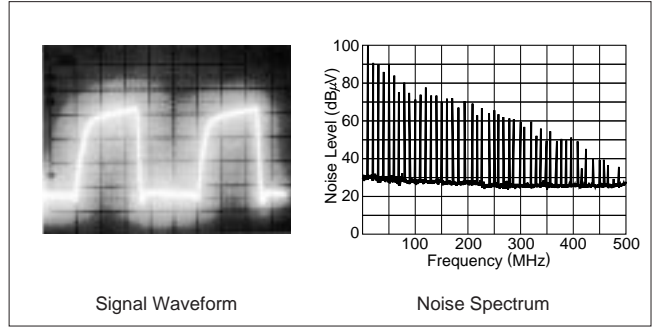

Waveform Change and Noise Suppression Effect when Filter is Inserted

Type of Filter	Signal Wave Form (20ns · 1V/div)	EMI Suppression Effect	Description
NFM51R Series (Cut-off frequency 50MHz)			The NFM51R's steep attenuation characteristic means excellent EMI suppression without waveform cornering.
Conventional Chip Solid Type EMI Filter (NFM41R 470pF)			3-terminal capacitors suppress signal frequencies as EMI frequencies so the signal waveform is distorted.
Filter Combined with Conventional LCs			Combinations of inductors and capacitors can yield a steep attenuation characteristic, but they require a great deal more mounting space. Moreover, at high frequencies the EMI suppression is less than that obtained by the NFM51R.

L : Chip Inductor
 C : Chip Capacitor
 (270pF)

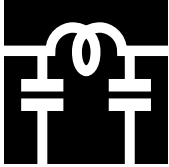

CHIP EMIFIL®

EMIFIL® is the trademark of Murata Manufacturing Co., Ltd.



Chip Solid EMIFIL® NFM40P/NFM41P/NFM46P Series

Large Rated Current 3 Terminal Capacitor in DC Power Line

Chip solid EMIFIL® NFM40P/NFM41P/NFM46P are 3 terminal structure SMT components. These components are able to be applied to large current DC power lines. NFM40P/41P/46P are suitable in noise suppression DC lines where relatively large currents operate.

FEATURES

- **NFM40P/NFM41P**
 1. The rated current of 2A is suitable for IC's individual power line.
 2. Small dimension enables higher density packaging. NFM40P is much smaller size. (3.2×1.25×0.7mm)
 3. Murata's original internal electrode structure design which realizes excellent EMI suppression effect from low frequency to high frequency .
- **NFM46P**
 1. Large insertion loss (over 30dB) can be obtained in frequency range from 500kHz to 1GHz .
 2. Large rated current (6A) and low voltage drop due to a small DC resistance are suitable for the application in DC power line.
 3. High electrostatic capacitance and remarkable high frequency performance are effective for the immunity against the surge noise and the pulse noise.
 4. Only reflow soldering should be applied.

APPLICATIONS

- Personal computers, Word processors and Peripherals
- Telephones, PPCs, Communication equipments, etc.
- Digital TVs, VCRs
- Telecommunication equipment

PART NUMBERING

(Please specify the part number when ordering.)

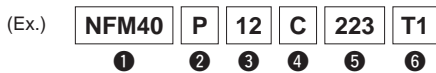

- ① Type
- ② Large current
- ③ Class No.
- ④ Circuit composition
- ⑤ Characteristics
- ⑥ Packaging code T1 : Taped
 B1 : Bulk Package

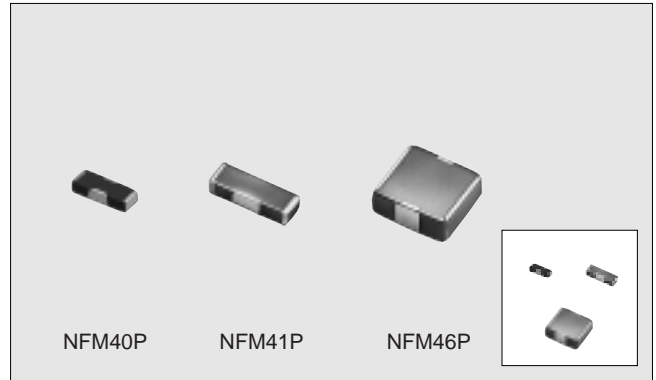

DIMENSIONS

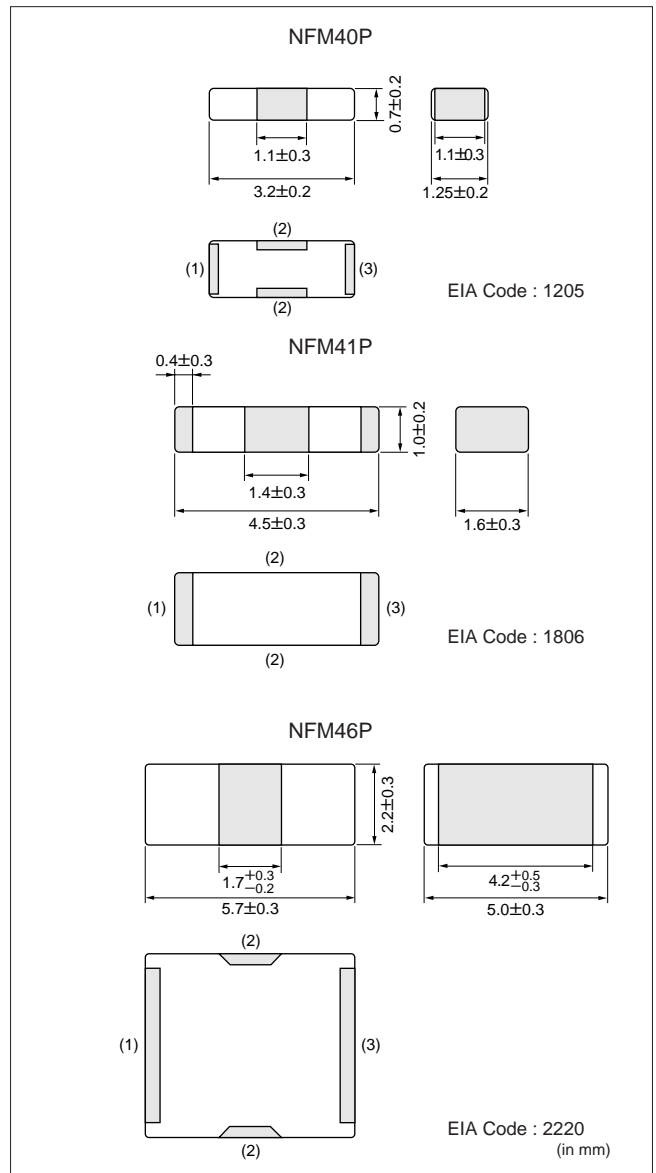

■SPECIFICATIONS

Part Number	Capacitance	Rated Voltage (VDC)	Rated Current (ADC)	Insulation Resistance (MΩ min.)	DC Resistance (1)–(3) (Ω max.)	Operating Temp. Range (°C)
NFM40P12C223	22000pF±20%	50	2	1000	0.05	-55 to +85
NFM41P11C204	200000pF± ⁸⁰ / ₂₀ % (0.2μF)				0.04	
NFM46P11C155	1.5μF± ⁸⁰ / ₂₀ %		6	100	0.01	

■INSERTION LOSS CHARACTERISTICS (TYPICAL)

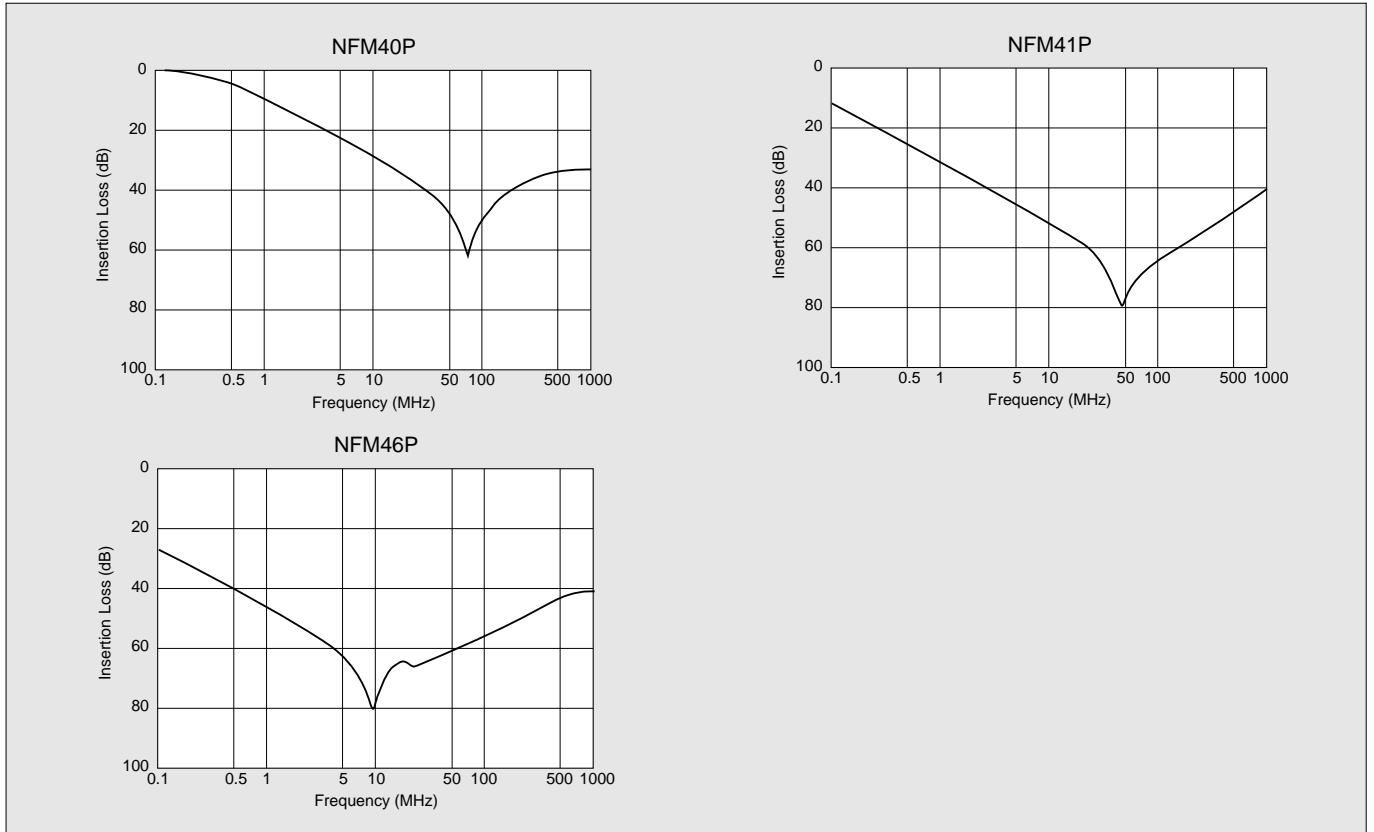

■EQUIVALENT CIRCUIT DIAGRAM

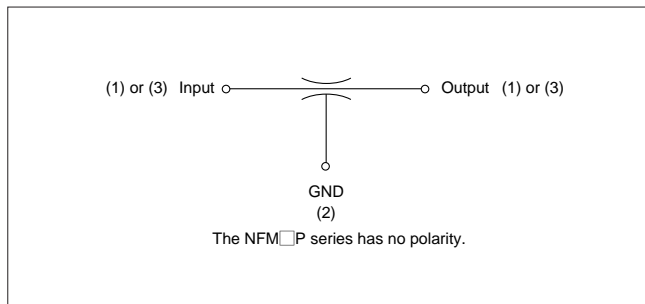

■INSERTION LOSS MEASURING CIRCUIT

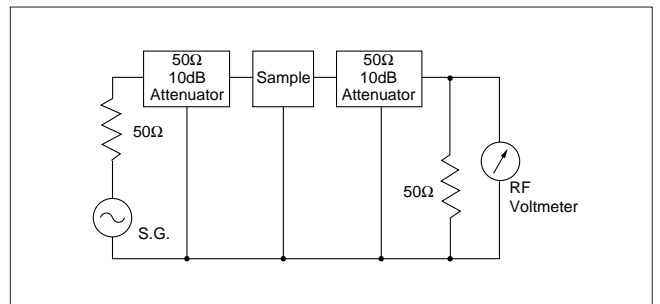

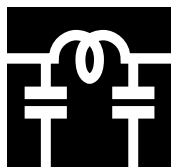

CHIP EMIFIL®

EMIFIL® is the trademark of Murata Manufacturing Co., Ltd.



T-type Chip EMIFIL® NFM60R/NFM61R/NFM61RH Series

Meets High Current of 6A T-Type Circuit Chip EMIFIL® with Ferrite Beads

FEATURES

1. Its large rated current and low voltage drop due to small DC resistance are suitable for DC power line use.
2. The feedthrough capacitor realized excellent high-frequency characteristics.
3. The structure incorporates built-in ferrite beads which minimize resonance with surrounding circuits.
4. For rugged operating environments such as automobile circuitry, Murata offers the heavy duty NFM61RH series. These filters have an extended operating temperature range of -55°C to $+125^{\circ}\text{C}$.
5. The series has excellent solder heat resistance. Both flow and reflow soldering method can be employed. (Reflow soldering should be employed with the NFM60R 1500pF, NFM61RH 3300pF filter.)

APPLICATIONS

- Office equipment such as personal computers, word processors and facsimiles
- Audio visual equipment such as TVs and VCRs

PART NUMBERING

(Please specify the part number when ordering.)

(Ex.)

NFM60R	00	T	101	T1
---------------	-----------	----------	------------	-----------

① ② ③ ④ ⑤

- ① Type
- ② Class No.
- ③ Circuit Composition
- ④ Characteristics
- ⑤ Packaging Code T1 : Taped
 B1 : Bulk package

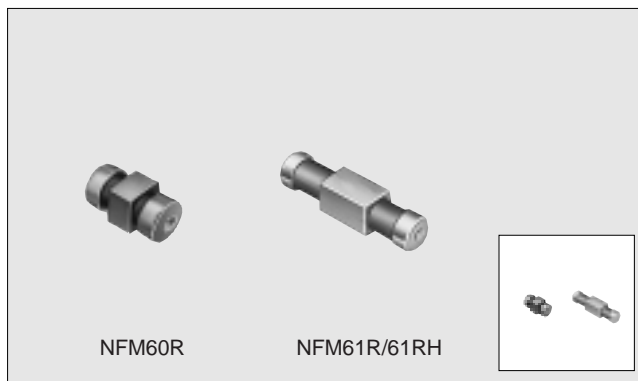

DIMENSIONS

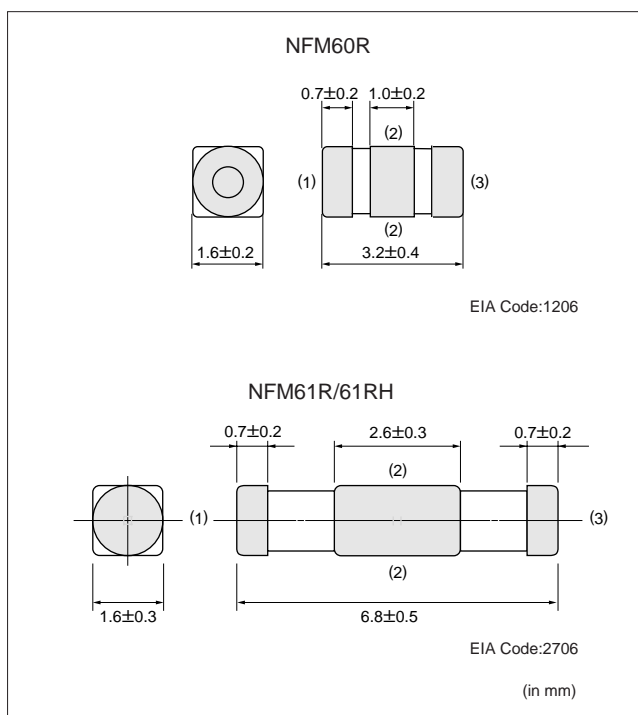

EQUIVALENT CIRCUIT DIAGRAM

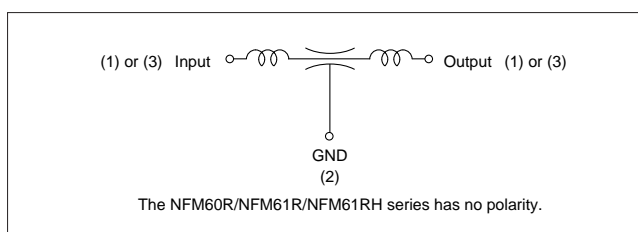

■SPECIFICATIONS

NFM60R Series (Compact Size Type)

Part Number	Capacitance	Rated Voltage	Rated Current	Insulation Resistance	Operating Temp. Range
NFM60R00T220	22pF±30%	25VDC	6ADC	1000MΩmin.	-40°C to +85°C
NFM60R00T470	47pF± $\frac{50}{20}\%$				
NFM60R00T101	100pF± $\frac{80}{20}\%$				
NFM60R00T221	220pF± $\frac{50}{20}\%$				
NFM60R10T471	470pF± $\frac{50}{20}\%$				
NFM60R20T152*1	1500pF± $\frac{50}{20}\%$				
NFM60R30T222	2200pF±50%				

*1 NFM60R20T152 is specially adapted for flow soldering. The flow soldering method should not be used.

NFM61R Series

Part Number	Capacitance	Rated Voltage	Rated Current	Insulation Resistance	Operating Temp. Range
NFM61R00T330*2	33pF±30%	50VDC	2ADC	1000MΩmin.	-25°C to +85°C
NFM61R00T680*2	68pF±30%				
NFM61R00T101	100pF±30%				
NFM61R00T181	180pF±30%				
NFM61R00T361	360pF±20%				
NFM61R00T681*2	680pF±30%				
NFM61R10T102	1000pF± $\frac{80}{20}\%$				
NFM61R30T472	4700pF± $\frac{80}{20}\%$				

NFM61RH Series (Heavy Duty Type)

Part Number	Capacitance	Rated Voltage	Rated Current	Insulation Resistance	Operating Temp. Range
NFM61RH00T330*2	33pF±30%	100VDC	2ADC	1000MΩmin.	-55°C to +125°C
NFM61RH00T680*2	68pF±30%				
NFM61RH00T101	100pF±30%				
NFM61RH00T181	180pF±30%				
NFM61RH00T361	360pF±20%				
NFM61RH00T681*2	680pF±30%				
NFM61RH10T102	1000pF± $\frac{80}{20}\%$				
NFM61RH20T332*2	3300pF± $\frac{80}{20}\%$				

*2 Marked items are not standard.

NFM61RH20T332 is specially adapted for reflow soldering. The flow soldering method should not be used.

■INSERTION LOSS CHARACTERISTICS (TYPICAL)

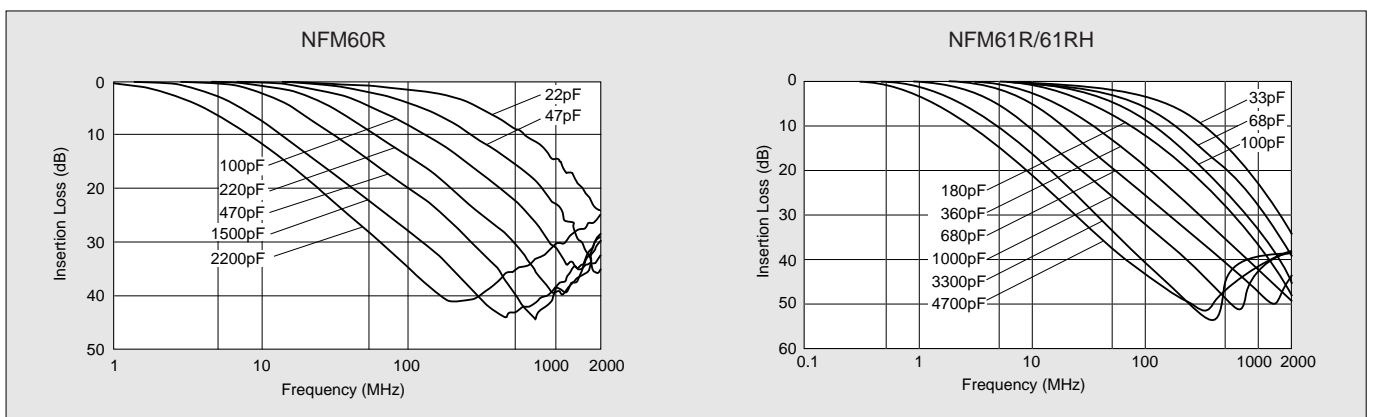

■INSERTION LOSS MEASURING CIRCUIT

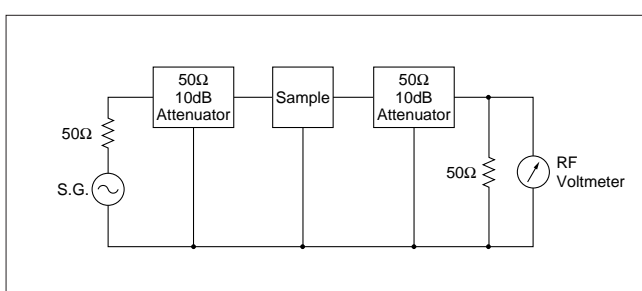

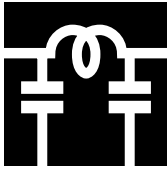

CHIP EMIFIL®

EMIFIL® is the trademark of Murata Manufacturing Co., Ltd.



Chip Solid EMIGUARD® VFM41R Series

The VFM41R series is a chip EMIFIL® with varistor function. Its 3-terminal structure provides high performance by suppressing high-frequency noise and absorbing surge noise.

FEATURES

1. The VFM41R series protect semiconductor unit from surge noise such as electrostatic discharge.
2. The VFM41R series suppress EMI noise in signal lines.
3. Chip shape enables high density mounting.

APPLICATIONS

- ESD surge protection and EMI suppression in various electric equipments such as car electronic equipments, portable electronic equipments, telecommunication terminals, office automation equipments, home automation equipments or factory automation equipments

PART NUMBERING

(Please specify the part number when ordering.)

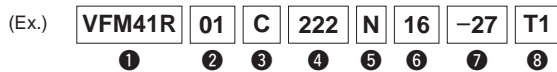

- ① Type
- ② Class No.
- ③ Circuit Composition
- ④ Capacitance
- ⑤ Capacitance Tolerance
- ⑥ Rated Voltage
- ⑦ Varistor Voltage
- ⑧ Packaging code T1 : Taped
 B1 : Bulk Package

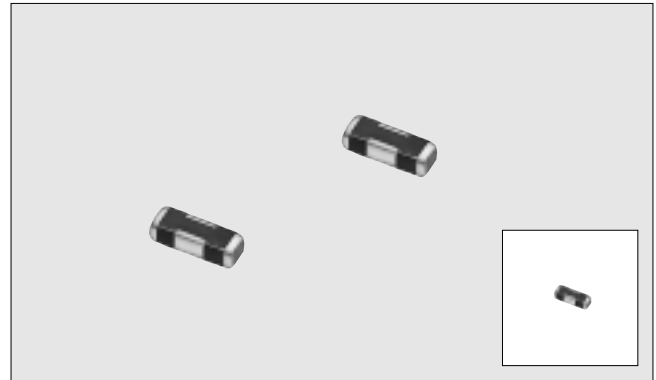

DIMENSIONS

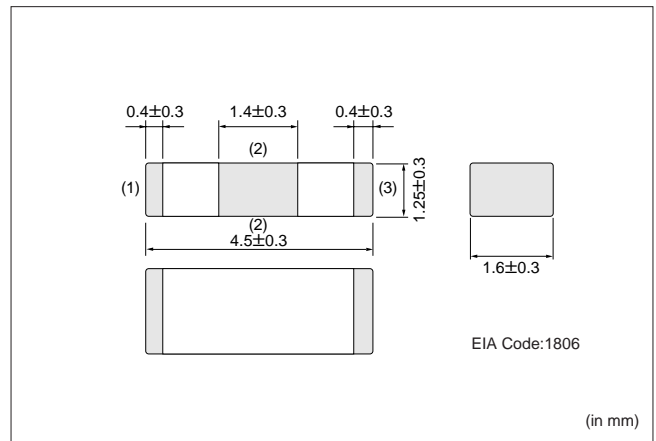

EQUIVALENT CIRCUIT DIAGRAM

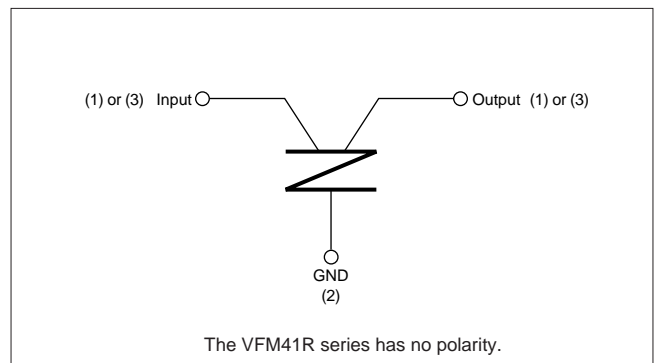

SPECIFICATIONS

Part Number	Rated Voltage (VDC)	Varistor Voltage (V)	Rated Current (mA)	Peak Pulse Current (A)	ESD Test (150pF, 330Ω)	Capacitance	Insulation Resistance (Ω) min.	Operating Temp. Range (°C)
VFM41R01C222N16-27	16	27±5	200	50	25kV, 10times	2200pF±30%	10M	-40 to +125

■ INSERTION LOSS CHARACTERISTICS (TYPICAL)

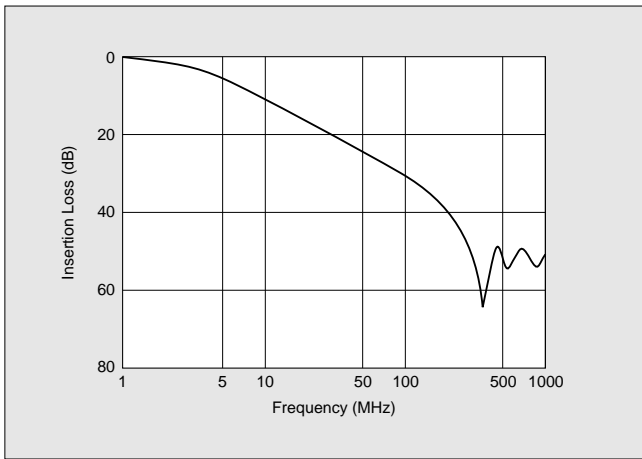

■ MEASURING CIRCUIT OF INSERTION LOSS

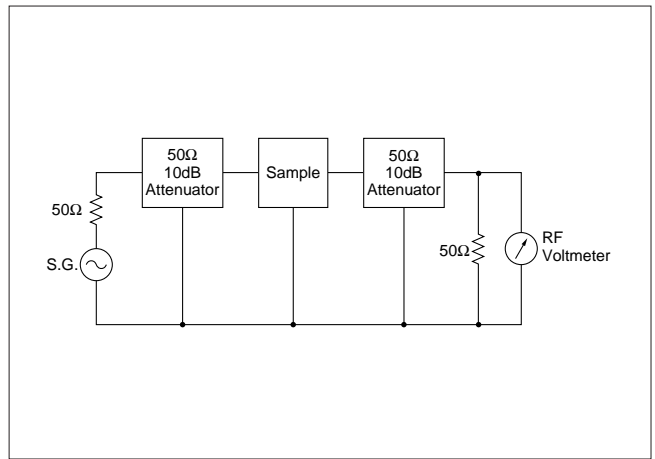

■ IMPULSE NOISE ABSORPTION (Comparison between VFM41R and Standard 2-terminal Varistor)

Impulse Generator
($Z_o=50\Omega$)
(Pulse Width 100nS)

*Final voltage comes below 0V because of the affect of signal reflection.

Output Voltage (V)

Time (nS)

174V peak

Original Waveform

Output Voltage (V)

Time (nS)

2225

1675

1125

575

25

The commonly used 2-terminal varistor

The rising part of pulse, which is mostly consists of high-frequency element, remains because inductance in electrodes becomes obstacle.

Output Voltage (dBm)

Frequency (LINEAR)

10MHz

990MHz

Original Waveform

The Lower chart is a frquency response of the upper chart. Note that the scale of original wave chart and that of the output wave chart is different because of circumstances.

Output Voltage (dBm)

Frequency (LINEAR)

10MHz

990MHz

Chip Solid EMIGUARD® VFM41R

The 3-terminal structure minimizes the effect of inductance in electrodes and pulse rising noise is absorbed completely.

Output Voltage (V)

Time (nS)

76V peak

Output Voltage (dBm)

Frequency (LINEAR)

10MHz

990MHz

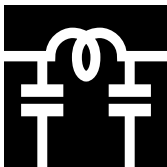

CHIP EMIFIL[®]

EMIFIL[®] is the trademark of Murata Manufacturing Co., Ltd.



Chip Common Mode Choke Coil PLM3216K Series

For common mode noise suppression in high speed signal lines. SMD, ultra small size common mode choke coil.

The PLM3216K series is effective in high frequency noise suppression and suitable for suppression of radiation noise in signal cables. The common mode choke coil structure enables noise suppression without damaging the signal. Murata's original material technology and monolithic technology enable a compact size of 3.2×1.6×1.15mm.

FEATURES

1. The PLM3216K series is effective for common mode noise suppression in digital equipment which causes radiation from cables.
2. Low leakage flux due to monolithic structure enables high density mounting.
3. The nickel barrier structure of the external electrodes provides excellent solder heat resistance.

APPLICATIONS

- Prevention of common mode noise on signal line in personal computers, computer built in equipments, facsimiles, digital telephones, etc.

PART NUMBERING

(Please specify the part number when ordering.)



- ① Type
- ② Typical Impedance at 100MHz
281 : 280Ω
- ③ Other Characteristics
- ④ Number of Line
- ⑤ Packaging code T1 : Taped
 B1 : Bulk Package

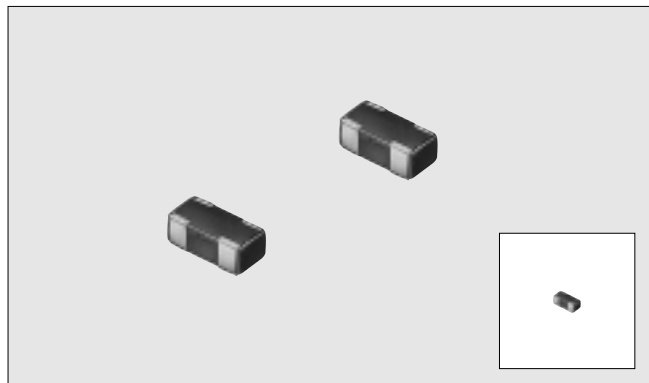

DIMENSIONS

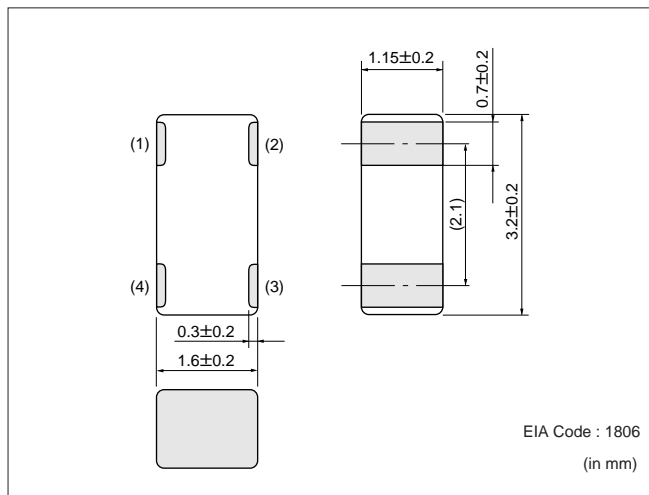

EQUIVALENT CIRCUIT DIAGRAM

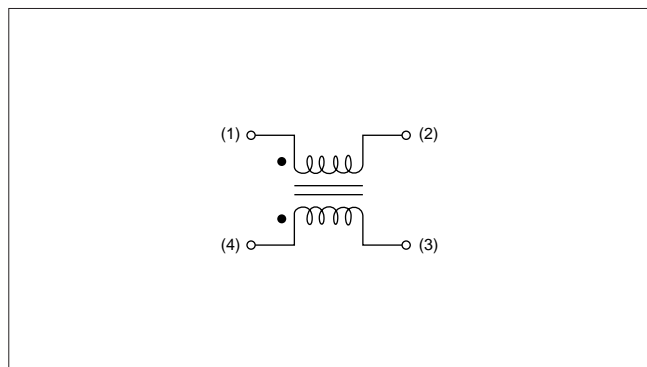

■SPECIFICATIONS

Part Number	Rated Current (mA)	Common mode Impedance (Ω) (Typ.) at 100MHz	Rated Voltage (VDC)	Withstand Voltage (VDC)	Insulation Resistance (Ω) min.	Operating Temp. Range ($^{\circ}$ C)
PLM3216K281SJ2	200	280	50	125	100M	-55 to +85

■IMPEDANCE-FREQUENCY CHARACTERISTICS

(TYPICAL)

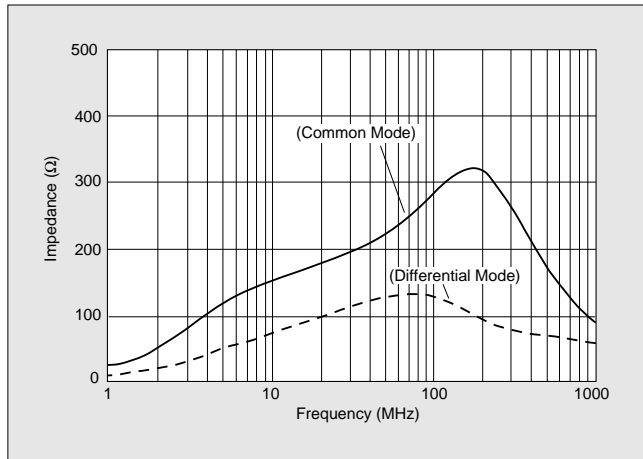

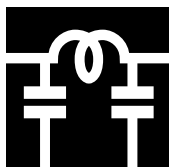

CHIP EMIFIL[®]

EMIFIL[®] is the trademark of Murata Manufacturing Co., Ltd.



Chip Common Mode Choke Coil **PLM250H/S Series**

Wire Wound Chip Type with High Impedance, Large Current, High Coupling Are Condensed into Small Chip

FEATURES

1. High impedance (maximum of 4kΩ at 100MHz : PLM250H10) enables great noise suppression.
2. Large rated current (maximum of 2A) enables power line use.
3. The PLM250 series dose not damage high speed signal due to high coupling common mode choke coil structure.
4. Automatic mounting can be applied.
5. The PLM250 series is specially adapted for reflow soldering.

APPLICATIONS

- Common mode noise suppression of signal lines in high speed digital equipment such as HDTVs, computers and peripherals
- Common mode noise suppression of DC power lines in AC adapter of notebook size computers, game machines and digital audio equipments

PART NUMBERING

(Please specify the part number when ordering.)



- ① Type
- ② Class No.
- ③ Packaging Code T1 : Taped (∅180mm reel)
 T2 : Taped (∅330mm reel)
 B1 : Bulk Package

EQUIVALENT CIRCUIT DIAGRAM

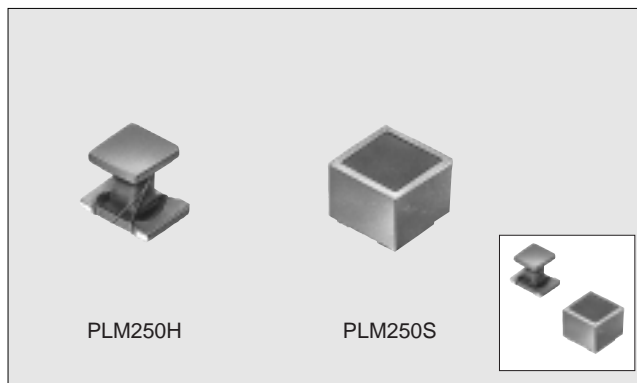
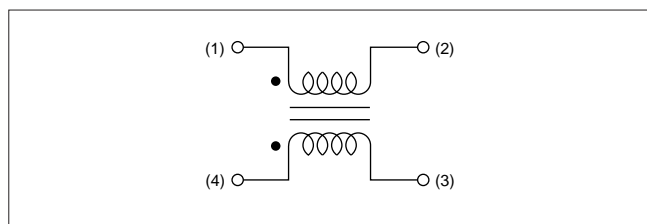

DIMENSIONS

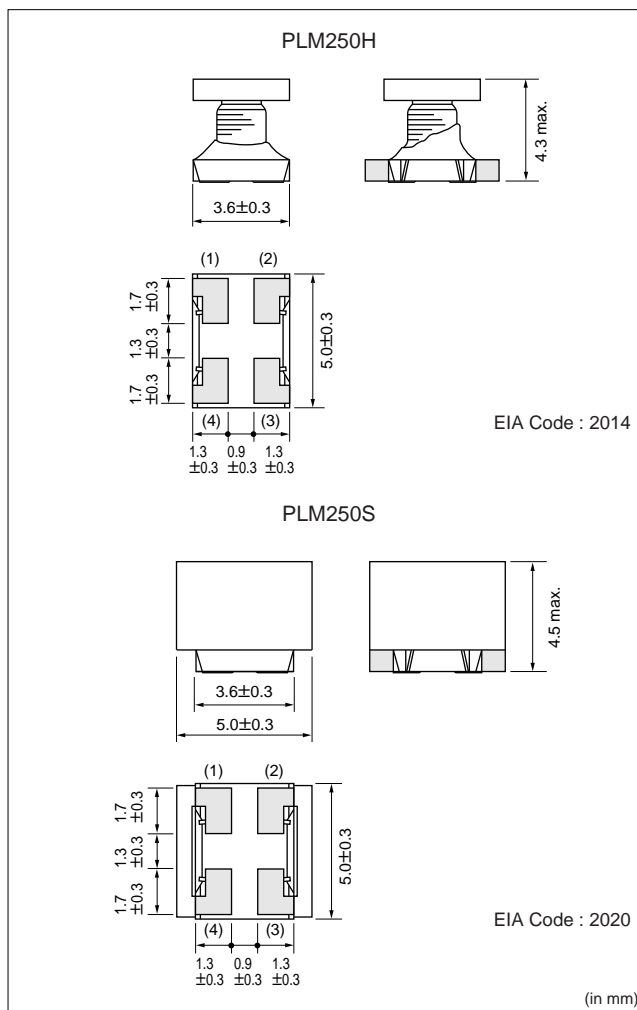

■SPECIFICATIONS

Part Number	Rated Current (A)	Impedance (Ω) (Typ.) at 100MHz	DC Resistance (Ω) max.	Rated Voltage (VDC)	Withstand Voltage (VDC)	Insulation Resistance (MΩ) min.	Operating Temp. Range (°C)
PLM250H10	0.2	4000	3.0	50	125	10	-25 to +85
PLM250S20	0.5	3000	0.3				
PLM250S30	1.0	1500	0.1				
PLM250S40	1.5	1000	0.06				
PLM250S50	2.0	350	0.04				

■IMPEDANCE-FREQUENCY CHARACTERISTICS (TYPICAL)

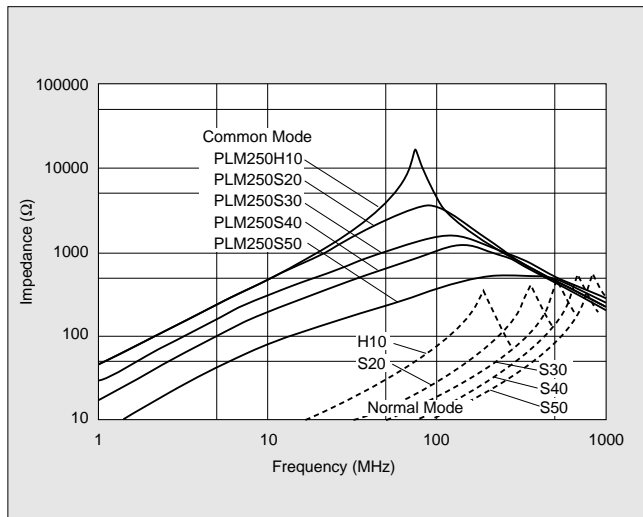

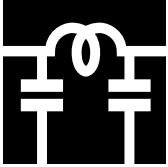

CHIP VARISTOR



Chip Varistor VCM11R/VCM21R

The surge test on electronic equipment tends to be popular because of the regulation for immunity. This situation require surge absorb components smaller dimension, lower cost and higher performance. VCM11R/21R are designed as absorbing devices which, with MURATA' s advanced technic, has higher performance in spite of its small dimension.

VCM11R/21R absorbs surge voltage, results to protect circuit simply by inserting between surge entrance line and ground line.

FEATURES

1. It is effective in high density packaging, because of smaller dimension than diode which is generally used as surge countermeasure devices.
2. The small clamping voltage ratio enables effective absorption of surge noise.
3. VCM11R can be applied in high speed signal line, because its capacitance is relatively small.
4. The large peak current of VCM21R, up to 150A, enables high reliability against surge.
5. VCM21R can be applied to ISO-7637-1. Test pulse condition.
6. The nickel barrier structure of the external electrodes provides excellent solder heat resistance. Both flow and reflow soldering methods can be applied.

APPLICATIONS

- Surge absorption in communication ports such as RS-232C.
- Motor/ relay noise absorption
- Electro static protection in I/O port of computers

PART NUMBERING

(Please specify the part number when ordering.)



- ① Type
- ② Style
- ③ Rated Voltage
- ④ Class No.
- ⑤ Peak Pulse Current
- ⑥ Packaging Code PT : Taped
 PB : Bulk package

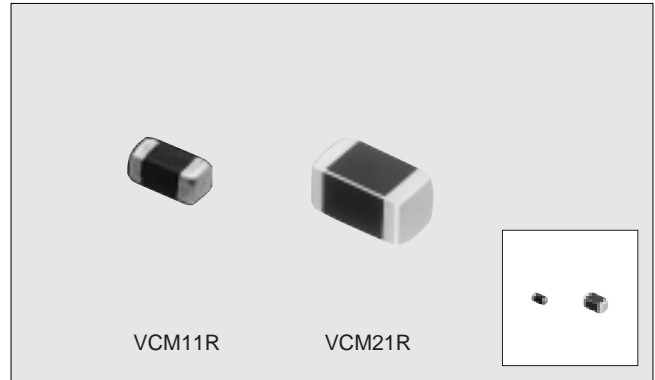

DIMENSIONS

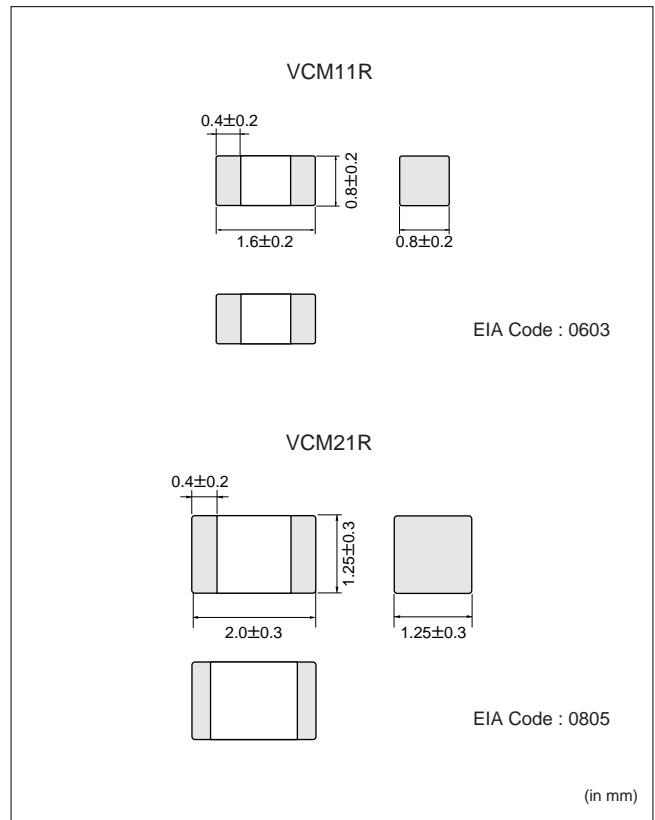

EQUIVALENT CIRCUIT DIAGRAM

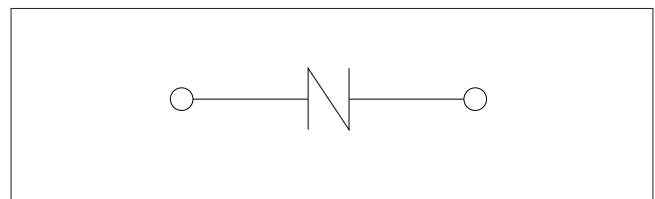

■SPECIFICATIONS

Part Number	Rated Voltage (VDC)	Varistor Voltage V1mA (V)	Clamping Voltage (V max.)	Peak Pulse Current 8/20 μ s (A)	Energy Rating (J)	ESD Test (150pF,330 Ω)	Capacitance 1MHz (pF)	Operating temp. Range (°C)
VCM11R180A300	18	29 \pm 5	50 (V1A)	30	0.05	8kV, 10 times	100 \pm 30%	-40 to+125
VCM21R180A151		25 \pm 5	45 (V10A)	150	0.3	25kV, 10 times	1000 \pm 30%	

■VOLTAGE-CURRENT CHARACTERISTICS (TYPICAL)

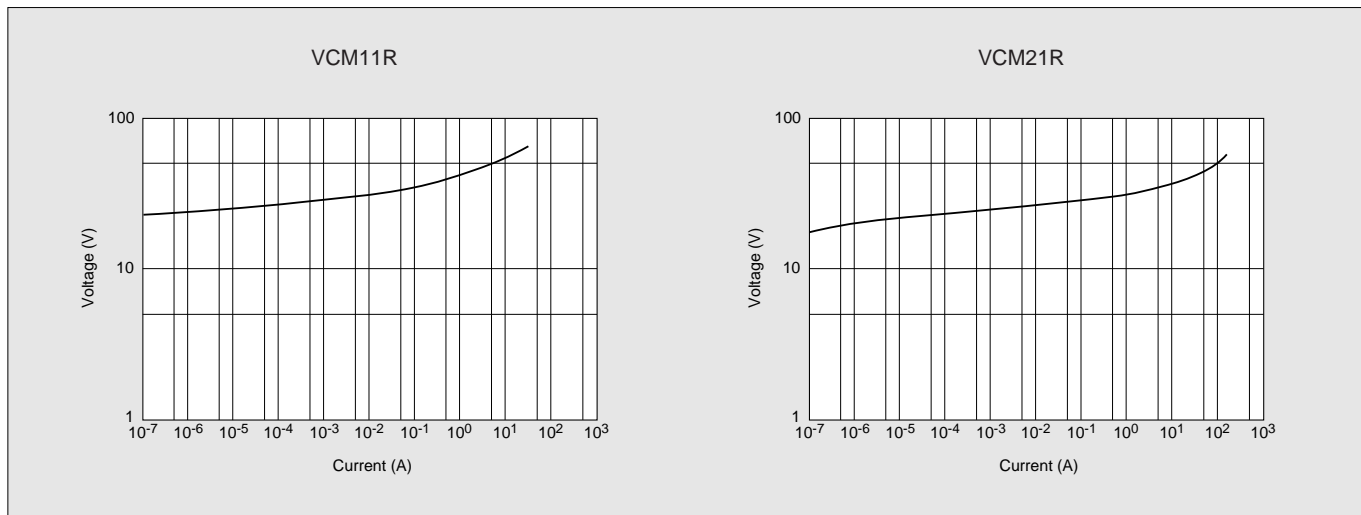





Notice of Chip EMIFIL®/Chip Varistor

1. Standard Land Pattern Dimensions

The capacitor type chip EMI suppression filters (NFM/NFA series) suppress noise by conducting the high-frequency noise element to ground. Therefore, to obtain maximum performance from these filters, the ground pattern should be made as large as possible during the PCB design stage.

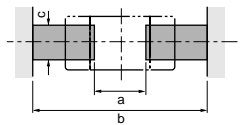
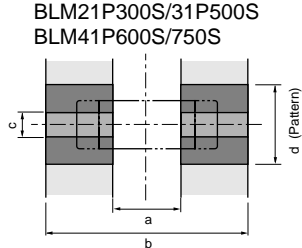
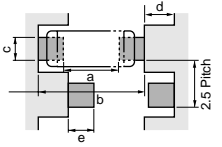
As shown below, one side of the PCB is used for chip mounting, and the other is used for grounding. Small diameter feedthrough holes are then used to connect the grounds on each side of the PCB. This reduces the high-frequency impedance of the grounding and maximizes the filter's performance.

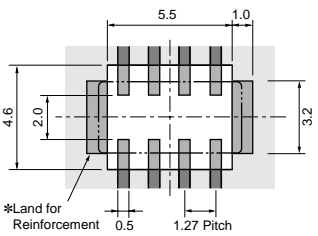
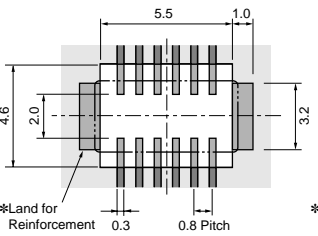
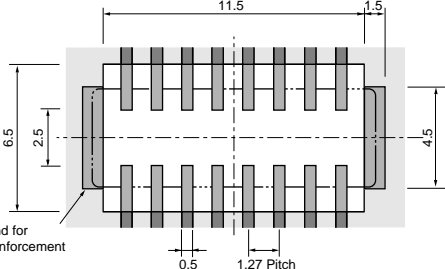
■ Copper Foil Pattern □ Resist (in mm)

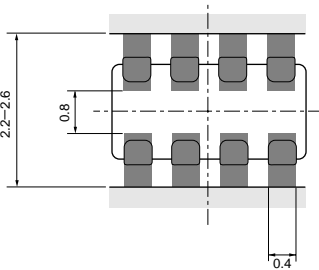
<p>BLM10/11/21/31/41</p> 	<p>● Reflow and Flow for Mounting Alone</p> <p>BLM Series (Except 21P300S, 31P500S, 41P600S/750S)</p>  <table border="1" data-bbox="331 840 718 1064"> <thead> <tr> <th rowspan="2">Type</th> <th colspan="5">Size (mm)</th> </tr> <tr> <th>L</th> <th>W</th> <th>a</th> <th>b</th> <th>c</th> </tr> </thead> <tbody> <tr> <td>BLM10</td> <td>1.0</td> <td>0.5</td> <td>0.4</td> <td>1.2-1.4</td> <td>0.5</td> </tr> <tr> <td>BLM11 (Flow)</td> <td>1.6</td> <td>0.8</td> <td>0.7</td> <td>2.2-2.6</td> <td>0.7</td> </tr> <tr> <td>BLM11 (Reflow)</td> <td>1.6</td> <td>0.8</td> <td>0.7</td> <td>1.8-2.0</td> <td>0.7</td> </tr> <tr> <td>BLM21</td> <td>2.0</td> <td>1.25</td> <td>1.2</td> <td>3.0-4.0</td> <td>1.0</td> </tr> <tr> <td>BLM31</td> <td>3.2</td> <td>1.6</td> <td>2.0</td> <td>4.2-5.2</td> <td>1.2</td> </tr> <tr> <td>BLM41</td> <td>4.5</td> <td>1.6</td> <td>3.0</td> <td>5.5-6.5</td> <td>1.2</td> </tr> </tbody> </table> <p>BLM21P300S/31P500S BLM41P600S/750S</p>  <table border="1" data-bbox="746 840 1077 1019"> <thead> <tr> <th rowspan="2">Type</th> <th colspan="3">Size (mm)</th> <th colspan="3">Land pad thickness and Dimension d</th> </tr> <tr> <th>a</th> <th>b</th> <th>c</th> <th>18 μm</th> <th>35 μm</th> <th>70 μm</th> </tr> </thead> <tbody> <tr> <td>BLM21P300S</td> <td>1.2</td> <td>3.0-4.0</td> <td>1.0</td> <td>2.4</td> <td>1.2</td> <td>1.00</td> </tr> <tr> <td>BLM31P500S</td> <td>2.0</td> <td>4.2-5.2</td> <td>1.2</td> <td>6.4</td> <td>3.3</td> <td>1.65</td> </tr> <tr> <td>BLM41P600S</td> <td>3.0</td> <td>5.5-6.5</td> <td>1.2</td> <td>2.4</td> <td>1.2</td> <td>1.20</td> </tr> </tbody> </table> <p>● Please contact us if using thinner land pad than 18μm.</p> <p>● Don't apply narrower pattern than listed above to BLM□□P. Narrow pattern can cause excessive heat or open circuit.</p>	Type	Size (mm)					L	W	a	b	c	BLM10	1.0	0.5	0.4	1.2-1.4	0.5	BLM11 (Flow)	1.6	0.8	0.7	2.2-2.6	0.7	BLM11 (Reflow)	1.6	0.8	0.7	1.8-2.0	0.7	BLM21	2.0	1.25	1.2	3.0-4.0	1.0	BLM31	3.2	1.6	2.0	4.2-5.2	1.2	BLM41	4.5	1.6	3.0	5.5-6.5	1.2	Type	Size (mm)			Land pad thickness and Dimension d			a	b	c	18 μm	35 μm	70 μm	BLM21P300S	1.2	3.0-4.0	1.0	2.4	1.2	1.00	BLM31P500S	2.0	4.2-5.2	1.2	6.4	3.3	1.65	BLM41P600S	3.0	5.5-6.5	1.2	2.4	1.2	1.20	<p>● Flow Mounting in High Density</p> <p>BLM31/41</p>  <table border="1" data-bbox="1141 840 1444 1008"> <thead> <tr> <th rowspan="2">Type</th> <th colspan="5">Size (mm)</th> </tr> <tr> <th>a</th> <th>b</th> <th>c</th> <th>d</th> <th>e</th> </tr> </thead> <tbody> <tr> <td>BLM31</td> <td>2.0</td> <td>4.2 to 5.2</td> <td>1.2</td> <td>1.3</td> <td>1.35</td> </tr> <tr> <td>BLM41</td> <td>3.0</td> <td>5.5 to 6.5</td> <td>1.2</td> <td>1.8</td> <td>1.5</td> </tr> </tbody> </table>	Type	Size (mm)					a	b	c	d	e	BLM31	2.0	4.2 to 5.2	1.2	1.3	1.35	BLM41	3.0	5.5 to 6.5	1.2	1.8	1.5
Type	Size (mm)																																																																																																									
	L	W	a	b	c																																																																																																					
BLM10	1.0	0.5	0.4	1.2-1.4	0.5																																																																																																					
BLM11 (Flow)	1.6	0.8	0.7	2.2-2.6	0.7																																																																																																					
BLM11 (Reflow)	1.6	0.8	0.7	1.8-2.0	0.7																																																																																																					
BLM21	2.0	1.25	1.2	3.0-4.0	1.0																																																																																																					
BLM31	3.2	1.6	2.0	4.2-5.2	1.2																																																																																																					
BLM41	4.5	1.6	3.0	5.5-6.5	1.2																																																																																																					
Type	Size (mm)			Land pad thickness and Dimension d																																																																																																						
	a	b	c	18 μm	35 μm	70 μm																																																																																																				
BLM21P300S	1.2	3.0-4.0	1.0	2.4	1.2	1.00																																																																																																				
BLM31P500S	2.0	4.2-5.2	1.2	6.4	3.3	1.65																																																																																																				
BLM41P600S	3.0	5.5-6.5	1.2	2.4	1.2	1.20																																																																																																				
Type	Size (mm)																																																																																																									
	a	b	c	d	e																																																																																																					
BLM31	2.0	4.2 to 5.2	1.2	1.3	1.35																																																																																																					
BLM41	3.0	5.5 to 6.5	1.2	1.8	1.5																																																																																																					
<p>BLA41/BLA62 BLA81</p> 	<p>● Reflow and Flow</p> <p>BLA41</p>  <p>BLA62</p>  <p>BLA81</p>  <p>*Land for Reinforcement 0.5 1.27 Pitch</p> <p>*Land for Reinforcement 0.3 0.8 Pitch</p> <p>*Land for Reinforcement 0.5 1.27 Pitch</p> <p>*The land for reinforcing electrode should be electrically isolated.</p>																																																																																																									
<p>BLA3216</p> 	<p>● Reflow and Flow</p>  <p>*The excessive heat by land pads may cause deterioration at joint of products with substrate.</p>																																																																																																									

Notice of Chip EMIFIL®/Chip Varistor

■ Copper Foil Pattern □ Resist (in mm)

NFM39R/40R/41R
NFM40P/41P
NFM839R
VFM41R



● Reflow Soldering

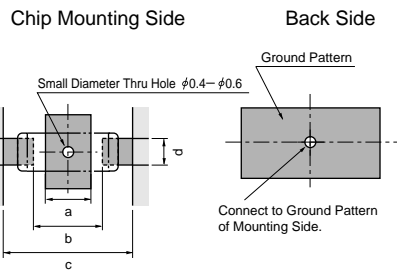

Type	Dimensions (mm)			
	a	b	c	d
NFM39R/839R	0.8	1.4	2.6	0.6
NFM40R/40P	1.4	2.5	4.4	1.0
NFM41R/41P VFM41R	2.0	3.5	6.0	1.2

● Flow Soldering

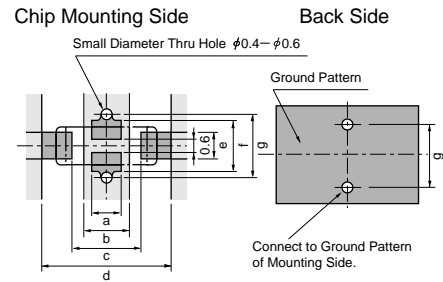

Type	Dimensions (mm)						
	a	b	c	d	e	f	g
NFM39R/839R	0.6	0.8	1.4	2.6	0.6	1.9	2.3
NFM40R/40P	1.0	1.4	2.5	4.4	1.0	2.0	2.4
NFM41R/41P VFM41R	1.5	2.0	3.5	6.0	1.2	2.6	3.0

NFA41R
NFA62R
NFA81R



● Reflow and Flow

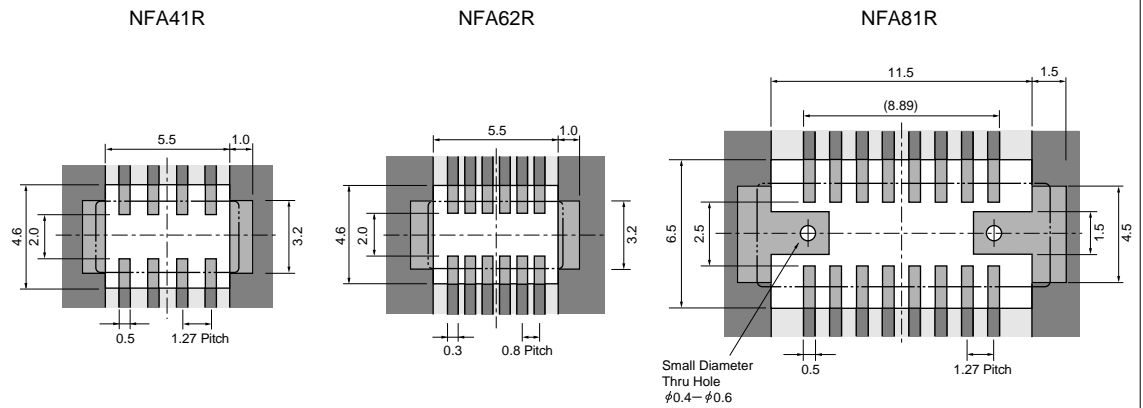

NFM51R
NFM60R



● Reflow and Flow

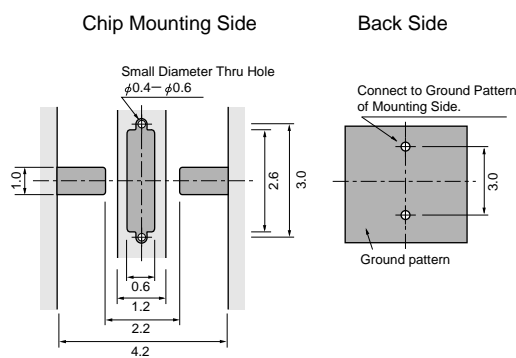

NFM61R
NFM61RH



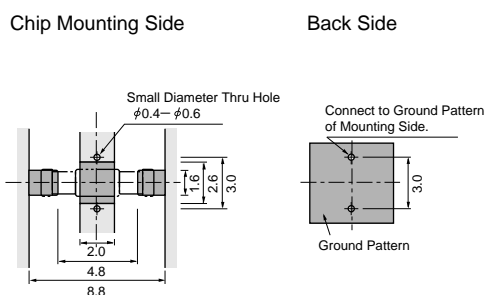

● Reflow Soldering



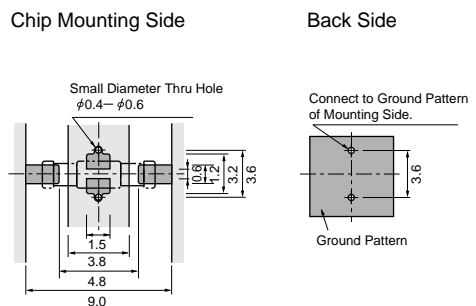

● Flow Soldering

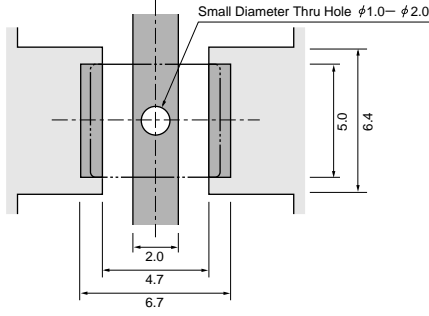
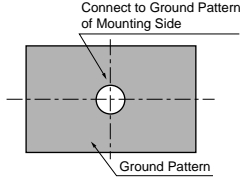

Notice of Chip EMIFIL[®]/Chip Varistor

 Copper Foil Pattern  Resist (in mm)

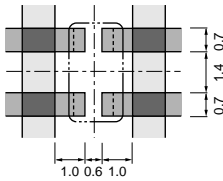
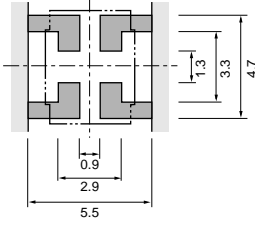
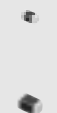
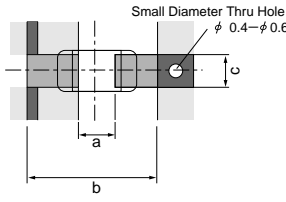
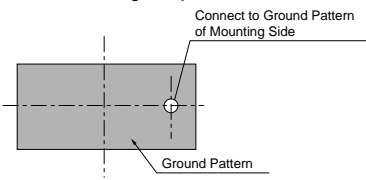
<p>NFM46P</p> 	<p>● Reflow Soldering</p> <p>Chip Mounting Side</p> 	<p>Back Side</p> <p>Ground on back side should be designed to be as large as possible.</p>  <ul style="list-style-type: none"> • NFM46P is specially adapted for reflow soldering. • Please contact us if using thinner land pad than 18 μm. 																						
<p>PLM3216K PLM250</p> 	<p>● Reflow and Flow</p> <p>PLM3216K</p> 	<p>● Reflow Soldering</p> <p>PLM250</p> 																						
<p>VCM11R VCM21R</p> 	<p>● Reflow and Flow</p> <p>Chip Mounting Side</p>  <table border="1" data-bbox="638 1456 1029 1579"> <thead> <tr> <th rowspan="2">Type</th> <th rowspan="2"></th> <th colspan="3">Size (mm)</th> </tr> <tr> <th>a</th> <th>b</th> <th>c</th> </tr> </thead> <tbody> <tr> <td rowspan="2">VCM11R</td> <td>Flow</td> <td>0.7</td> <td>2.2-2.6</td> <td>0.7</td> </tr> <tr> <td>Reflow</td> <td>0.7</td> <td>1.8-2.0</td> <td>0.7</td> </tr> <tr> <td>VCM21R</td> <td></td> <td>1.2</td> <td>3.0-4.0</td> <td>1.0</td> </tr> </tbody> </table>	Type		Size (mm)			a	b	c	VCM11R	Flow	0.7	2.2-2.6	0.7	Reflow	0.7	1.8-2.0	0.7	VCM21R		1.2	3.0-4.0	1.0	<p>Back Side</p> <p>Ground on back side should be designed to be as large as possible.</p> 
Type				Size (mm)																				
		a	b	c																				
VCM11R	Flow	0.7	2.2-2.6	0.7																				
	Reflow	0.7	1.8-2.0	0.7																				
VCM21R		1.2	3.0-4.0	1.0																				

Notice of Chip EMIFIL®/Chip Varistor

2. Solder Paste Printing and Adhesive Application

When reflow soldering the chip EMI suppression filter/Chip Varistor, the printing must be conducted in accordance with the following cream solder printing conditions.

If too much solder is applied, the chip will prone to be damaged by mechanical and thermal stress from the PCB and may crack.







In contrast, if too little solder is applied, there is the potential that the termination strength will be insufficient, creating the potential for detachment.

Standard land dimensions should be used for resist and copper foil patterns.

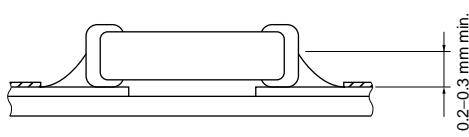
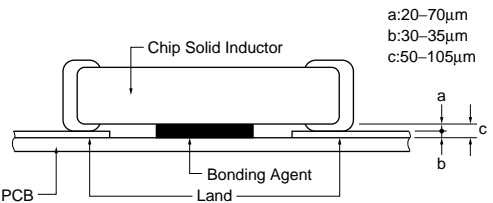
When flow soldering the EMI suppression filter/Chip Varistor, apply the adhesive in accordance with the following conditions.

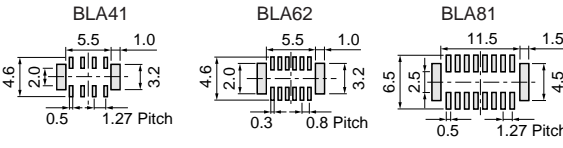
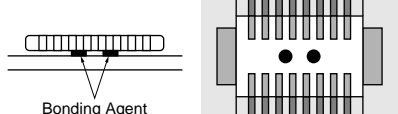

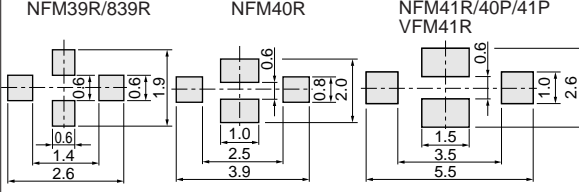
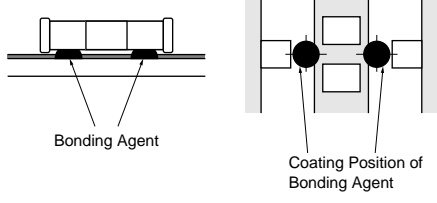

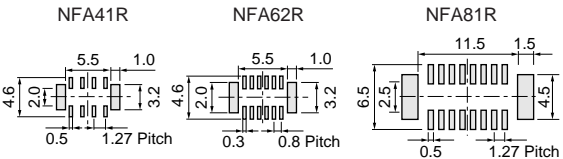
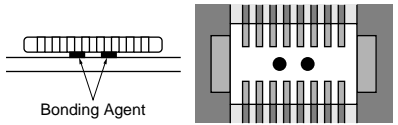

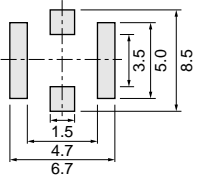
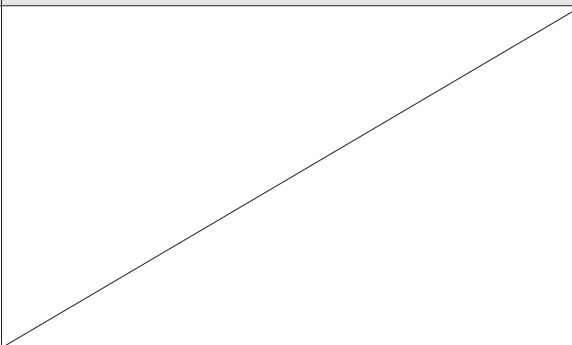

If too much adhesive is applied, then it may overflow into the land or termination areas and yield poor solderability. In contrast, if insufficient adhesive is applied, or if the adhesive is not sufficiently hardened, then the chip may become detached during flow soldering.

(in mm)

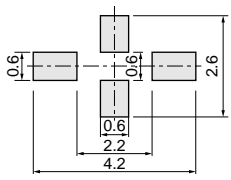
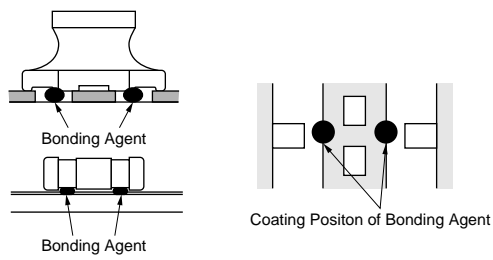
Series	Solder Paste Printing	Adhesive Application
<p>BLM10/11/21/31/41 BLA3216 VCM11R/21R</p> 	<ul style="list-style-type: none"> Ensure that solder is applied smoothly to a minimum height of 0.2mm to 0.3mm at the end surface of the part. Coat the solder paste a thickness of 100 μm to 200 μm. 	<ul style="list-style-type: none"> Coating amount is illustrated in the following diagram. 
<p>BLA41/62/81</p> 	<ul style="list-style-type: none"> Coat the solder paste a thickness of 100 μm to 200 μm (BLA41), 150 μm (BLA62), and 200 μm (BLA81). Use H60A solder for pattern printing. 	<ul style="list-style-type: none"> Apply 0.5mg to 0.9mg for BLA81 and 0.25mg to 0.6mg for BLA41/62 of bonding agent at each chip, and ensure not to cover electrodes. 
<p>NFM39R/40R/41R NFM40P/41P NFM839R VFM41R</p> 	<ul style="list-style-type: none"> Coat the solder paste a thickness of 100 μm to 150 μm (NFM39R/40R/839R/40P) and 100 μm to 200 μm (NFM41R/41P, VFM41R). Use H60A solder for pattern printing. 	<ul style="list-style-type: none"> Apply 0.1mg for NFM41R/41P, VFM41R and 0.06mg for NFM40R/40P and 0.05mg for NFM39R/839R of bonding agent at each chip. 
<p>NFA41R/62R/81R</p> 	<ul style="list-style-type: none"> Coat the solder paste a thickness of 150 μm (NFA62R/41R) and 200 μm (NFA81R). Use H60A solder for pattern printing. 	<ul style="list-style-type: none"> Apply 0.5mg to 0.9mg for NFA81R and 0.25mg to 0.6mg for NFA62R/41R of bonding agent at each chip, and ensure not to cover electrodes. 

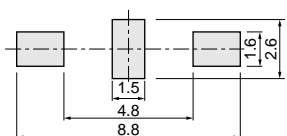
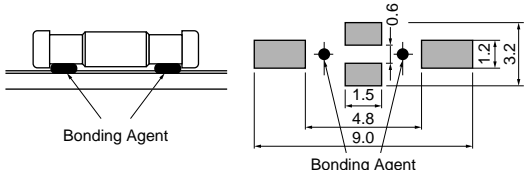
Notice of Chip EMIFIL®/Chip Varistor

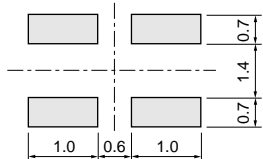
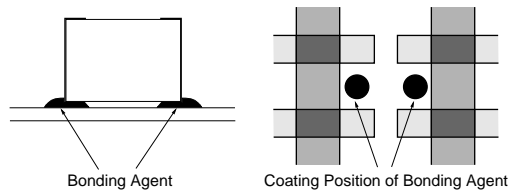
(in mm)

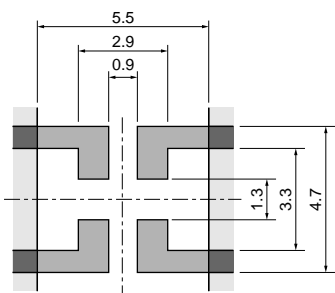
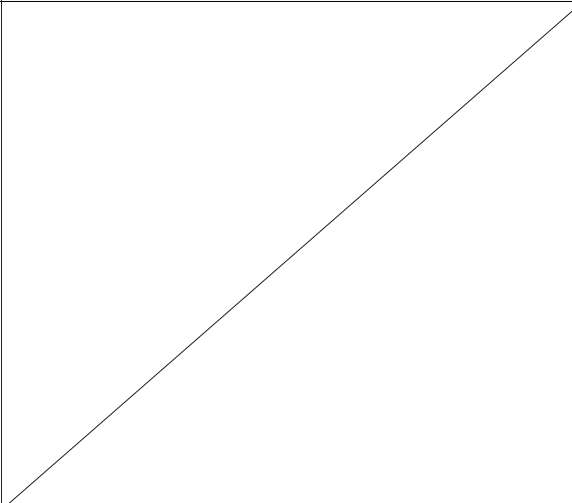
Series	Solder Paste Printing	Adhesive Application
<p>NFM46P</p> 	<ul style="list-style-type: none"> Coat the solder paste a thickness of 200 μm. Use H60A solder for pattern printing. 	
<p>NFM51R NFM60R</p> 	<ul style="list-style-type: none"> Coat the solder paste a thickness of 200 μm (NFM51R) and 150 μm (NFM60R). Use H60A solder for pattern printing. 	<ul style="list-style-type: none"> Apply 0.2mg of bonding agent at each chip. 
<p>NFM61R/61RH</p> 	<ul style="list-style-type: none"> Coat the solder paste a thickness of 200 μm. Use H60A solder for pattern printing. 	<ul style="list-style-type: none"> Apply 1.0mg of bonding agent at each chip. 
<p>PLM3216K</p> 	<ul style="list-style-type: none"> Coat the solder paste a thickness of 150 μm. Use H60A solder for pattern printing. 	<ul style="list-style-type: none"> Apply 0.3mg of bonding agent at each chip. 
<p>PLM250</p> 	<ul style="list-style-type: none"> Coat the solder paste a thickness of 200 μm. Use H60A solder for pattern printing. 	

Notice of Chip EMIFIL®/Chip Varistor

3. Standard Soldering Conditions

(1)Soldering Methods

Use flow and reflow soldering methods only.
 Use standard soldering conditions when soldering chip EMI suppression filters, Chip Varistor.
 In cases where several different parts are soldered, each having different soldering conditions, use those conditions requiring the least heat and minimum time.

(2)Soldering Temperature and Time

To prevent external electrode solder leaching and performance deterioration, solder within the temperature and time combinations illustrated by the slanted lines in the following graphs. If soldering is repeated, please note that the allowed time is the accumulated time.

• Allowable Flow Soldering Temperature and Time

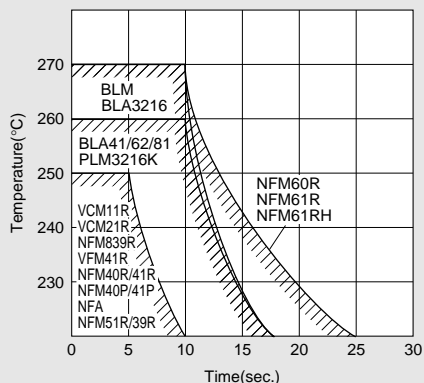

• Allowable Reflow Soldering Temperature and Time

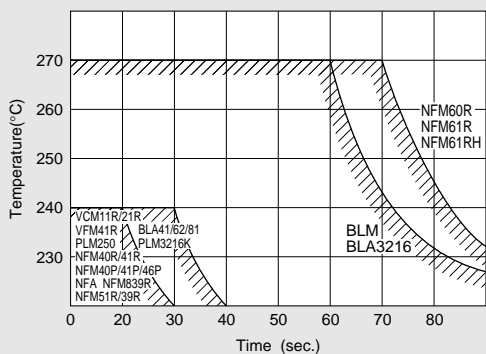

(3)Solder and Flux

Solder : H60A solder.
 Flux : Use Rosin-based flux, but not strong acidic flux (with chlorine content exceeding 0.20wt%).
 When using RA type solder, clean products sufficiently to avoid remaining flux.

(4)Reworking with Soldering Iron

The following conditions must be strictly followed when using a soldering iron.
 Soldering iron : 30W max.
 Tip Temperature : 280°C max.
 Soldering Time : 10 seconds max.
 Do not allow the tip of the soldering iron to directly contact the chip.

(5)Soldering Conditions

• Flow Solder

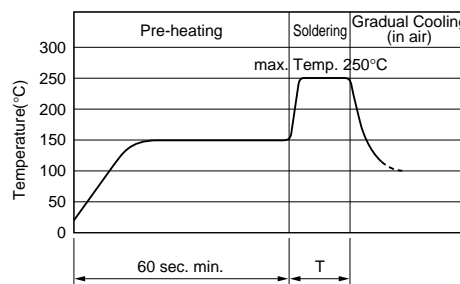

Series	Pre-heating (150°C)	Soldering Time (T)	Soldering Temp. (°C)
BLM, BLA3216	60sec. min.	10sec. max.	250
BLA41/62/81, NFA, NFM40R/41R, NFM40P/41P, NFM51R/39R, NFM839R, NFM61R(H)/60R, VFM41R, PLM3216K		5sec. max.	

• Reflow Solder

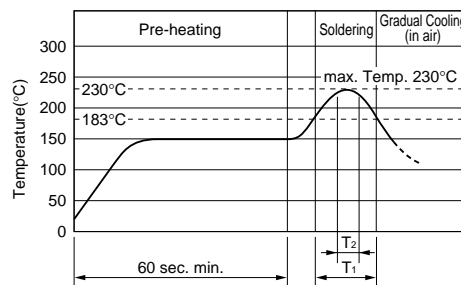

Series	Pre-heating (150°C)	Soldering Time	
		(T1) (183°C)	(T2) (230°C)
NFM61R(H)/60R	60sec. min.	60sec. max.	250°C, 20sec. max.
BLM, BLA3216			20sec. max.
BLA41/62/81, NFA, NFM39R/40R/41R, NFM40P/41P/46P, NFM51R, VFM41R, PLM3216K/250, VCM11R/21R, NFM839R	60sec. min.	60sec. max.	10sec. max.

Notice of Chip EMIFIL[®]/Chip Varistor

4. Cleaning

Following conditions should be observed when cleaning chip EMIFIL[®].

- (1) Cleaning temperature : 60°C max. (40°C max. for CFC alternatives and alcohol cleaning agents)
- (2) Ultrasonic
 - Output : 20W/l max.
 - Duration : 5 minutes max.
 - Frequency : 28 to 40kHz
- (3) Cleaning agent

The following list of cleaning agents have been tested on the individual components. Evaluation of final assembly should be completed prior to production.

 1. CFC alternatives and alcohol cleaning agents
 - Isopropyl alcohol (IPA)
 - HCFC-225
 2. Aqueous cleaning agent (PLM250 cannot be cleaned)
 - Surface active agent (Clean Thru 750H)
 - Hydrocarbon (Techno Cleaner 335)
 - High grade alcohol (Pine Alpha ST-100S)*
 - * VFM41R/VCM11R/21R series cannot be cleaned with high grade alcohol type aqueous cleaning agent.
 - Alkaline saponifier (Aqua Cleaner 240-cleaner should be diluted within 20% using deionized water.)
- (4) Ensure that flux residue is completely removed. Component should be thoroughly dried after aqueous agent has been removed with deionized water.
- (5) Some products may become slightly whitened. However, product performance or usage is not affected. For additional cleaning methods, please contact Murata engineering.

5. Operating Environment

Do not use products in corrosive gas such as chlorine gas, acid or sulfide gas.

6. Storage and Handling Requirements

- (1) Storage conditions
 - Storage temperature : -10 to +40°C
 - Relative humidity : 30 to 70%
 - Avoid sudden changes in temperature and humidity.
- (2) Do not store products in corrosive gas such as chlorine gas, acid or sulfide gas.

■WARNING

1. Rated Current/Rated Voltage/Operating Temperature
 - Don't use products beyond the rated current, the rated voltage and the operating temperature range, or, a fire may result due to the deterioration of the insulation resistance, excessive heat, etc.
2. Mounting Density
 - Give special attention when mounting products close to other product that radiate heat. The excessive heat by other products may cause deterioration of insulation resistance and excessive heat at this product, resulting in the fire.

Tape Dimensions of Chip EMIFIL[®]/Chip Varistor (EIA-J:RC-1009B)

Missing components number

The number of missing components are less than which-ever greater, 1piece or 0.1% of specified quantity per reel.

The missing components are not continued. The specified quantity per reel are kept.

BLM10/11/21/31, BLA3216, NFM39R/839R/40R/40P/51R/60R, VCM11R/21R, PLM3216K (8mm width paper/plastic tape)

*BLM10 : 2.0±0.1

2.0±0.1, 4.0±0.1, 4.0±0.1, φ1.5^{+0.1}₋₀, 1.75±0.1, 3.5±0.1, 8.0±0.3

Direction of Feed

(There are holes in the cavities of the BLM21B222S/272S/BLM31 only. φ1.0^{+0.3}₋₀)

Please contact us for BLM10/11 in bulk case.

(in mm)

Part Number	Cavity Size				Minimum Quantity(pcs/reel)		Type
	a	b	c	d	φ180mm	φ330mm	
BLM10	1.15	0.65	0.8		10,000	—	Paper
BLM11	1.85	1.05	1.1	—	4,000	10,000	
BLM21 (Except B222S/B272S)	2.25	1.45	1.1		4,000	10,000	
BLA3216	3.25	1.8	1.1	—	4,000	—	Plastic
BLM21 B222S/B272S	2.25	1.45	1.3	0.2	3,000	10,000	
BLM31 (A700S)	3.5	1.9	1.3 (1.75)		3,000 (2,500)	10,000 (8,000)	
NFM39R/839R	2.3	1.55	0.7	0.25	4,000	—	
NFM40R/40P	3.4	1.4	0.85	0.2	4,000	—	
NFM51R/60R	3.6	1.9	2.0		2,000	—	
VCM11R	1.85	1.05	0.95	0.25	4,000	—	
VCM21R	2.25	1.45	1.3	0.3	3,000	—	
PLM3216K	3.5	1.9	1.3	0.25	3,000	—	

BLM41, NFM41R/41P, NFM61R/61RH, VFM41R (12mm width plastic tape)

2.0±0.1, 4.0±0.1, 4.0±0.1, φ1.5^{+0.1}₋₀, 1.75±0.1, 5.5±0.1, 12.0±0.3

Direction of Feed

(There are holes in the cavities of the BLM41 only. φ1.5^{+0.3}₋₀)

(in mm)

Part Number	Cavity Size			Minimum Quantity(pcs/reel)	
	a	b	c	φ 180mm	φ 330mm
BLM41	4.8	1.9	1.75	2,500	8,000
NFM41R/41P	4.8	1.8	1.1	4,000	—
NFM61R/61RH	7.2	1.9	1.75	2,500	8,000
VFM41R	4.8	1.8	1.35	2,500	—

BLA62/41, NFA62R/41R, NFM46P, PLM250 (12mm width plastic tape)

2.0±0.1, 8.0±0.1, 4.0±0.1, φ1.5^{+0.1}₋₀, 1.75±0.1, 5.5±0.1, 12.0±0.3

Direction of Feed

φ1.5^{+0.3}₋₀ (NFM46P: φ1.7±0.1)

PLM250 is arranged in this direction of circuit in the tape.

(in mm)

Part Number	Cavity Size			Minimum Quantity(pcs/reel)	
	a	b	c	φ180mm	φ330mm
BLA62/41	6.6	3.5	1.13	1,000	—
NFA62R/41R	6.0	5.3	2.5	500	—
NFM46P	6.0	5.3	2.5	500	—
PLM250S (PLM250H)	5.5 (5.4)	5.4 (4.1)	4.7 (4.4)	400	1,500

BLA81/NFA81R (24mm width plastic tape)

8.0±0.1, 4.0±0.1, φ1.5^{+0.1}₋₀, 1.75±0.1, 11.5±0.1, 24.0±0.3

Direction of Feed

φ1.5^{+0.3}₋₀, 4.8

(in mm)

Minimum Quantity (order in sets only) : 1,000pcs./reel (φ180mm)

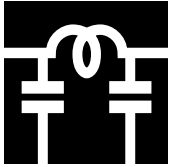

CHIP EMIFIL®

EMIFIL® is the trademark of Murata Manufacturing Co., Ltd.



Chip EMI Suppression Filter Design Kit EK115E

■Chip EMIFIL® Design Kit EK115E

The chip EMI suppression filter design kit EK115E has each of the filters in a plastic case to facilitate selection when testing the noise suppression capabilities of the EMIFIL® range.

The kit can be used equally well either on-site or in the laboratory.

(When ordering, please use the part number EK115E.)

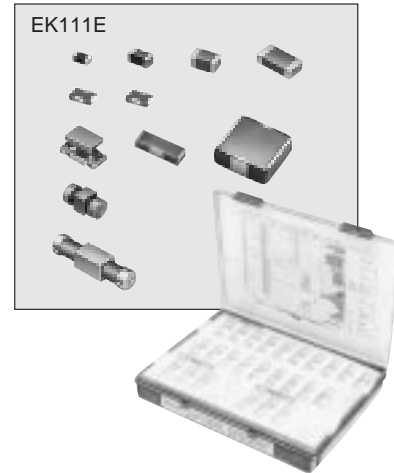

No.	Part Number	QTY.(pcs.)	Remark	
1	BLM11P300S	20	Chip Ferrite Bead Inductor	Small Size
2	BLM11P600S	20		Large Current
3	BLM11A121S	20		High Impedance
4	BLM11A221S	20		
5	BLM11A601S	20		
6	BLM11A102S	20		
7	BLM11B750S	20		Sharp Impedance Characteristics Suit for High-Speed Signal Line
8	BLM11B141S	20		
9	BLM11B421S	20		
10	BLM11B601S	20		
11	BLM11B102S	20		Large Current
12	BLM11B182S	20		
13	BLM21P300S	20		
14	BLM21A121F	20		
15	BLM21A401S	20		
16	BLM21A601F	20		Sharp Impedance Characteristics Suit for High-Speed Signal Line
17	BLM21A102F	20		
18	BLM21B050S	20		
19	BLM21B750S	20		
20	BLM21B201S	20		
21	BLM21B421S	20		
22	BLM21B601S	20		
23	BLM21B751SD	20		
24	BLM21B102S	20		
25	BLM21B222S	20		
26	BLM21B272S	20		Large Current
27	BLM31P500S	20		
28	BLM41P600S	10		
29	BLM41P750S	10		
30	BLM41P800S	10		

● Continue to next page.

No.	Part Number	QTY.(pcs.)	Remark		
31	NFM39R02C220	20	Chip Solid EMIFIL®	Wide Band Noise Suppression Effect Small Size For Signal Line	
32	NFM39R02C470	20			
33	NFM39R02C101	20			
34	NFM39R12C221	20			
35	NFM39R12C471	20			
36	NFM39R12C102	20			
37	NFM39R12C222	20			
38	NFM39R12C223	20			
39	NFM41P11C204	15			For Power Line
40	NFM46P11C155	5			
41	NFM839R02C101R101	10	Chip EMIFIL® for Signal Lines	Distributed Constant Waveform Distortion Prevention	
42	NFM839R02C470R101	10			
43	NFM839R02C101R470	10			
44	NFM839R02C470R470	10			
45	NFM51R00P106	10		Steep Attenuation Characteristics Suit for High-Speed Signal Line	
46	NFM51R00P206	10			
47	NFM51R00P506	10			
48	NFM51R10P107	10			
49	NFM51R20P207	10			
50	NFM51R30P507	10			
51	NFM60R00T220	10	Chip EMIFIL® Rectangular Type	Large Rated Current For Power Line	
52	NFM60R00T221	10			
53	NFM60R30T222	10			
54	NFM61R00T101	10			
55	NFM61R00T181	10			
56	NFM61R00T361	10			
57	NFM61R10T102	10			
58	NFM61R30T472	10			

- Please use the products in this Design Kit for experiment or test production, but do not use for mass production. When using for mass production, please order them after confirming detailed specifications by approving the appropriate individual specification sheet.

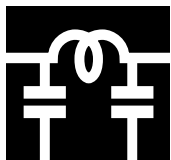

CHIP EMIFIL®

EMIFIL® is the trademark of Murata Manufacturing Co., Ltd.



Chip EMI Suppression Filter Design Kits

〈Design Kit for individual series〉

Part Number	Contents
EKEM11UA	BLM11/21/31/41, BLA3216 Series
EKEM12UA	NFM51R/839R/39R/41P/46P/60R/61R Series

EKEM11UA

No.	Part Number	Qty.
1	BLM10A100S	20
2	BLM10A700S	20
3	BLM10A121S	20
4	BLM11A121S	20
5	BLM11A221S	20
6	BLM11A471SG	20
7	BLM11A601S	20
8	BLM11A102S	20
9	BLM11B050SB	20
10	BLM11B100SB	20
11	BLM11B220SB	20
12	BLM11B470SB	20
13	BLM11B750S	20
14	BLM11B121SB	20
15	BLM11B121SD	20
16	BLM11B221SB	20
17	BLM11B221SD	20
18	BLM11B471SB	20
19	BLM11B471SD	20
20	BLM11B601S	20
21	BLM11B102S	20
22	BLM11B182S	20
23	BLM11B252SD	20
24	BLM21A121F	20
25	BLM21A221SG	20
26	BLM21A471SG	20
27	BLM21A601F	20
28	BLM21A102F	20
29	BLM21B750S	20
30	BLM21B121SB	20

EKEM12UA

No.	Part Number	Qty.
31	BLM21B121SD	20
32	BLM21B221SB	20
33	BLM21B221SD	20
34	BLM21B471SB	20
35	BLM21B471SD	20
36	BLM21B601S	20
37	BLM21B102S	20
38	BLM21B222SD	20
39	BLM21B272S	20
40	BLM31A601S	20
41	BLM31B601S	20
42	BLM11P300S	20
43	BLM11P600S	20
44	BLM21P300S	20
45	BLM31P500S	20
46	BLM41P600S	20
47	BLM41P750S	20
48	BLM41P800S	20
49	BLA3216A300SG4	5
50	BLA3216A600SG4	5
51	BLA3216A121SG4	5
52	BLA3216A221SG4	5
53	BLA3216A601SG4	5
54	BLA3216B121SD4	5
55	BLA3216B221SD4	5
56	BLA3216B471SD4	5

No.	Part Number	Qty.
1	NFM51R00P106	20
2	NFM51R00P206	20
3	NFM51R00P506	20
4	NFM51R10P107	20
5	NFM51R20P207	20
6	NFM51R30P507	20
7	NFM839R02C101R470	20
8	NFM839R02C470R470	20
9	NFM839R02C101R101	20
10	NFM839R02C470R101	20
11	NFM39R02C220	20
12	NFM39R02C470	20
13	NFM39R02C101	20
14	NFM39R12C221	20
15	NFM39R12C471	20
16	NFM39R12C102	20
17	NFM39R12C222	20
18	NFM39R12C223	20
19	NFM41P11C204	20
20	NFM46P11C155	20
21	NFM60R00T220	20
22	NFM60R00T470	20
23	NFM60R00T101	20
24	NFM60R00T221	20
25	NFM60R10T471	20
26	NFM60R20T152	20
27	NFM60R30T222	20
28	NFM61R00T681	20
29	NFM61R10T102	20
30	NFM61R30T472	20

● Please use the products in this Design Kit for experiment or test production, but do not use for mass production. When using for mass production, please order them after confirming detailed specifications by approving the appropriate individual specification sheet.

**Note:**

1. Export Control

<For customers outside Japan>

Murata products should not be used or sold for use in the development, production, stockpiling or utilization of any conventional weapons or mass-destructive weapons (nuclear weapons, chemical or biological weapons, or missiles), or any other weapons.

<For customers in Japan>

For products which are controlled items subject to "the Foreign Exchange and Foreign Trade Control Law" of Japan, the export license specified by the law is required for export.

2. Please contact our sales representatives or engineers before using our products listed in this catalog for the applications requiring especially high reliability what defects might directly cause damage to other party's life, body or property (listed below) or for other applications not specified in this catalog.

- ① Aircraft equipment
- ② Aerospace equipment
- ③ Undersea equipment
- ④ Medical equipment
- ⑤ Transportation equipment (automobiles, trains, ships, etc.)
- ⑥ Traffic signal equipment
- ⑦ Disaster prevention / crime prevention equipment
- ⑧ Data-processing equipment
- ⑨ Applications of similar complexity or with reliability requirements comparable to the applications listed in the above

3. Product specifications in this catalog are as of September 1997, and are subject to change or stop the supply without notice. Please confirm the specifications before ordering any product. If there are any questions, please contact our sales representatives or engineers.

4. The categories and specifications listed in this catalog are for information only. Please confirm detailed specifications by checking the product specification document or requesting for the approval sheet for product specification, before ordering.

5. Please note that unless otherwise specified, we shall assume no responsibility whatsoever for any conflict or dispute that may occur in connection with the effect of our and/or third party's intellectual property rights and other related rights in consideration of your using our products and/or information described or contained in our catalogs. In this connection, no representation shall be made to the effect that any third parties are authorized to use the rights mentioned above under licenses without our consent.

6. None of ozone depleting substances (ODS) under the Montreal Protocol is used in manufacturing process of us.

muRata Murata Manufacturing Co., Ltd.<http://www.murata.co.jp/>**Headquarters**

2-26-10, Tenjin Nagaokakyo-shi, Kyoto 617, Japan Phone:81-75-951-9111

International Division1-18-1 Hakusan, Midori-ku, Yokohama-shi, Kanagawa 226, Japan
Phone:81-45-931-7111 Fax:81-45-931-7105

<U.S.A.>

Murata Electronics North America, Inc.
2200 Lake Park Drive Smyrna, GA 30080-7604, U.S.A.
Phone:1-770-436-1300 Fax:1-770-436-3030

<BRAZIL>

Murata Amazônia Indústria e Comércio Ltda.
Alameda Santos, 1.893-6^o andar-conj. 62-São Paulo-SP
CEP 01419-910
Phone:55-11-287-7188 Fax:55-11-289-8310**Murata World Comercial Ltda.**Rua Fortaleza, 221-Bairro Adrianópolis-Manaus-AM CEP 69053-510
Phone:55-92-234-4351 Fax:55-92-234-5878

<GERMANY>

Murata Elektronik Handels GmbH
Holbeinstrasse 21-23,90441 Nürnberg, Germany
Phone:49-911-66870 Fax:49-911-6687411

<FRANCE>

Murata Electronique S.A.
18, 22, Avenue Edouard Herriot Copernic 6 92356 Le Plessis Robinson
Cedex, France
Phone:33-1-4094-8300 Fax:33-1-4094-0154

<ITALY>

Murata Elettronica S.p.A.
Via San Carlo, 1 20040 Caponago, Milano, Italy
Phone:39-2-95743000 Fax:39-2-95740168/95742292

<ENGLAND>

Murata Electronics(UK)Ltd.
Oak House, Ancells Road, Ancells Business Park, Fleet, Aldershot
Hampshire, GU13 8UN U.K.
Phone:44-1252-811666 Fax:44-1252-811777

<NETHERLANDS>

Murata Electronics(Netherlands)B.V.
Daalmeerstraat 4 2131 HC Hoofddorp, The Netherlands
Phone:31-23-5698410 Fax:31-23-5698411

<SWITZERLAND>

Murata Ageltro Electronics AG
Isenrietstrasse 19, CH-8617 Mönchaltorf Switzerland
Phone:41-1-948-1314 Fax:41-1-948-1769

<SINGAPORE>

Murata Electronics Singapore(Pte.)Ltd.
547 Yishun Industrial Park A. 7 Singapore 768766 Republic of
Singapore Phone:65-758-4233 Fax:65-758-2026

<MALAYSIA>

Murata Trading(Malaysia)Sdn.Bhd.
Suite 1510, Plaza Pengkalan, Batu 3 Jalan Ipoh, 51200 Kuala Lumpur
Malaysia
Phone:60-3-442-5227 Fax:60-3-443-8018**Murata Trading(Malaysia)Sdn.Bhd. Penang Office**
9.06 Wisma Tahwa No.39 Jalan Sultan Ahmad Shah 10050 Pulau
Penang Malaysia
Phone:60-4-229-4258 Fax:60-4-229-4257

<TAIWAN>

Murata Electronics North America, Inc. Taiwan Branch
Room 1403, Chia Hsin Building 96, Chung-Shan N. Rd., Sec. 2, Taipei
Taiwan
Phone:886-2-562-4218 Fax:886-2-536-6721

<THAILAND>

Murata Electronics(Thailand)Ltd.
No.62, Thaniya Building, 3rd Floor Silom Road, Bangkok, 10500
Kingdom of Thailand
Phone:66-2-236-3512/3491 Fax:66-2-238-4873
Thai Murata Electronics Trading,Ltd.
Phone:66-2-266-0750 Fax:66-2-266-0752

<HONG KONG>

Murata Co.,Ltd.
Room 709-712, Miramar Tower, 1-23 Kimberly Road, Tsimshatsui,
Kowloon, Hong Kong
Phone:852-2376-3898 Fax:852-2375-5655

<KOREA>

Murata Mfg.Co.,Ltd. Seoul Branch
14th Floor Haesung 2 Bldg., 942-10, Taechi-Dong, Kangnam-Ku,
Seoul, Korea
Phone:82-2-561-2347 Fax:82-2-561-2722

<CHINA>

Beijing Murata Electronics Co.,Ltd.
No.11 Tianzhu Road Tianzhu Airport Industry Zone Shunyi County,
Beijing 101312 the People's Republic of China
Phone:86-10-6456-8822 Fax:86-10-6456-9945**Murata Electronics Trading(Shanghai)Co.,Ltd.**
Room No.506, West Tower Sun Plaza 88 Xianxia Road, Changning
District Shanghai, 200335 P.R.C.
Phone:86-21-6270-0611/2/3 Fax:86-21-6270-0614