

NHD-3.12-25664UCB2

Graphic OLED Display Module

NHD-	Newhaven Display
3.12-	3.12" diagonal size
25664-	256 x 64 pixel resolution
UC-	Model
B-	Emitting Color: Blue
2-	+2.95V power supply

Newhaven Display International, Inc.

2661 Galvin Ct.

Elgin IL, 60124

Ph: 847-844-8795

Fax: 847-844-8796

www.newhavendisplay.com

nhtech@newhavendisplay.com

nhsales@newhavendisplay.com

Document Revision History

Revision	Date	Description	Changed by
0	5/1/2011	Initial Product Release	-
1	2/22/2013	Electrical characteristics and mechanical drawing updated	JN
2	5/2/16	Supply Current Updated	SB

Functions and Features

- 256 x 64 pixel resolution
- Built-in SSD1322 controller
- Parallel or serial MPU interface
- Single, low voltage power supply
- RoHS compliant

Mechanical Drawing

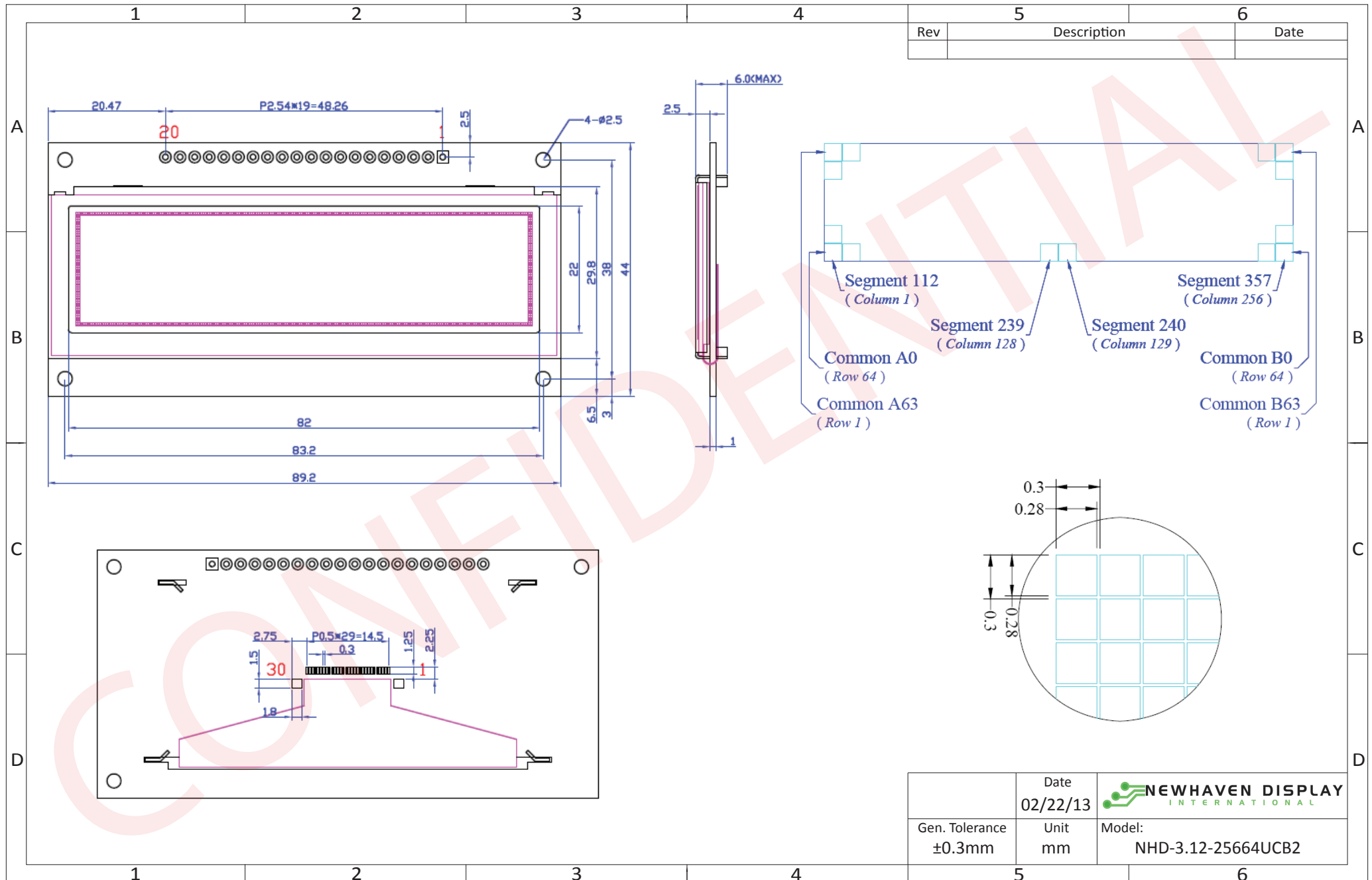

Rev	Description	Date

	Date 02/22/13	 NEWHAVEN DISPLAY <small>INTERNATIONAL</small>
Gen. Tolerance ±0.3mm	Unit mm	

The drawing contained herein is the exclusive property of Newhaven Display International, Inc. and shall not be copied, reproduced, and/or disclosed in any format without permission.

Interface Description

Parallel Interface:

Pin No.	Symbol	External Connection	Function Description
1	VSS	Power Supply	Ground
2	VDD	Power Supply	Supply Voltage for OLED and logic.
3	NC	-	No Connect
4	D/C	MPU	Register select signal. D/C=0: Command, D/C=1: Data
5	R/W or /WR	MPU	6800-interface: Read/Write select signal, R/W=1: Read R/W: =0: Write 8080-interface: Active LOW Write signal.
6	E or /RD	MPU	6800-interface: Operation enable signal. Falling edge triggered. 8080-interface: Active LOW Read signal.
7-14	DB0 – DB7	MPU	8-bit Bi-directional data bus lines.
15	NC	-	No Connect
16	/RES	MPU	Active LOW Reset signal.
17	/CS	MPU	Active LOW Chip Select signal.
18	NC	-	No Connect
19	BS1	MPU	MPU Interface Select signal.
20	BS0	MPU	MPU Interface Select signal.

Serial Interface:

Pin No.	Symbol	External Connection	Function Description
1	VSS	Power Supply	Ground
2	VDD	Power Supply	Supply Voltage for OLED and logic.
3	NC	-	No Connect
4	D/C	MPU	Register select signal. D/C=0: Command, D/C=1: Data Tie LOW for 3-wire Serial Interface.
5-6	VSS	Power Supply	Ground
7	SCLK	MPU	Serial Clock signal.
8	SDIN	MPU	Serial Data Input signal.
9	NC	-	No Connect
10-14	VSS	Power Supply	Ground
15	NC	-	No Connect
16	/RES	MPU	Active LOW Reset signal.
17	/CS	MPU	Active LOW Chip Select signal.
18	NC	-	No Connect
19	BS1	MPU	MPU Interface Select signal.
20	BS0	MPU	MPU Interface Select signal.

MPU Interface Pin Selections

Pin Name	6800 Parallel 8-bit interface	8080 Parallel 8-bit interface	3-wire Serial Interface	4-wire Serial Interface
BS1	1	1	0	0
BS0	1	0	1	0

MPU Interface Pin Assignment Summary

Bus Interface	Data/Command Interface							Control Signals					
	D7	D6	D5	D4	D3	D2	D1	D0	E	R/W	/CS	D/C	/RES
8-bit 6800	D[7:0]							E	R/W	/CS	D/C	/RES	
8-bit 8080	D[7:0]							/RD	/WR	/CS	D/C	/RES	
3-wire SPI	Tie LOW				NC	SDIN	SCLK		Tie LOW	/CS	Tie LOW	/RES	
4-wire SPI	Tie LOW				NC	SDIN	SCLK		Tie LOW	/CS	D/C	/RES	

Wiring Diagrams

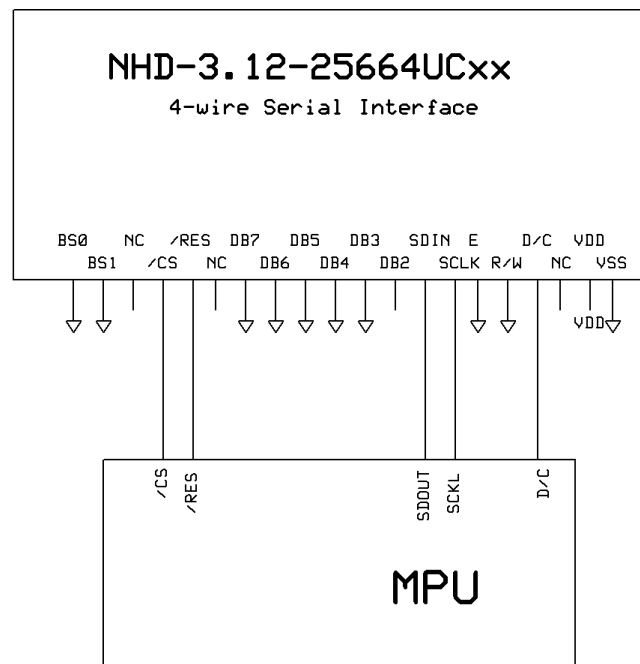
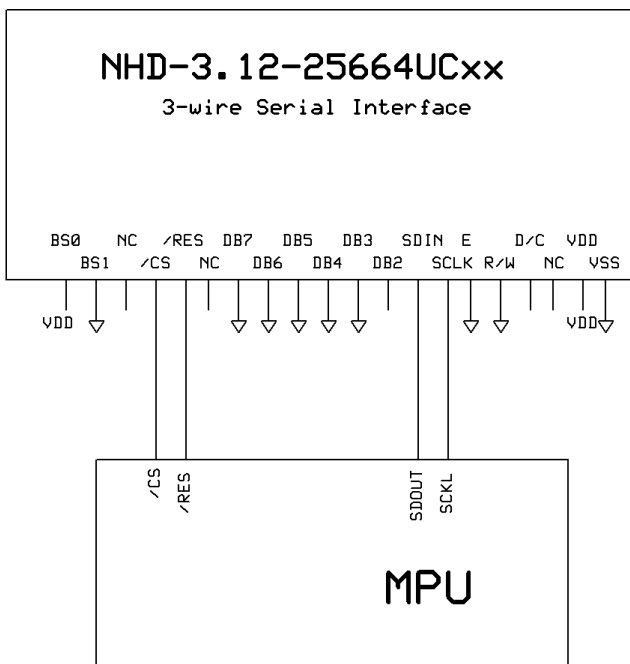
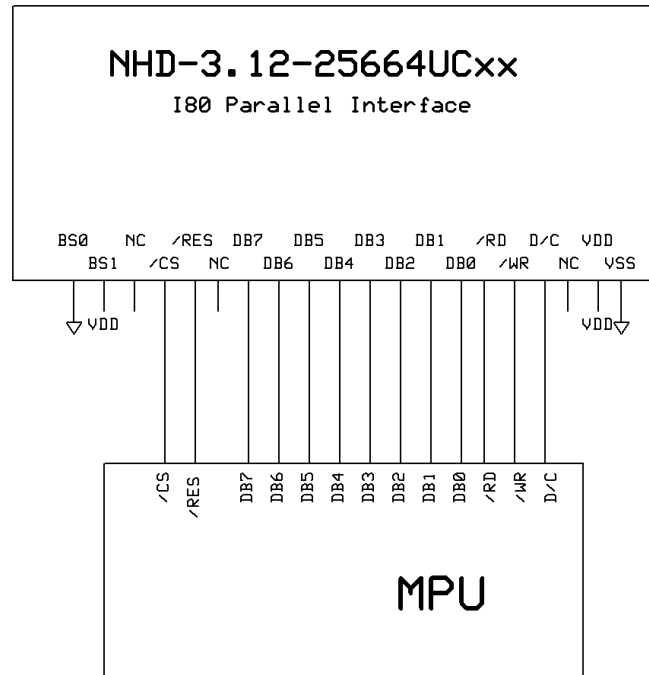
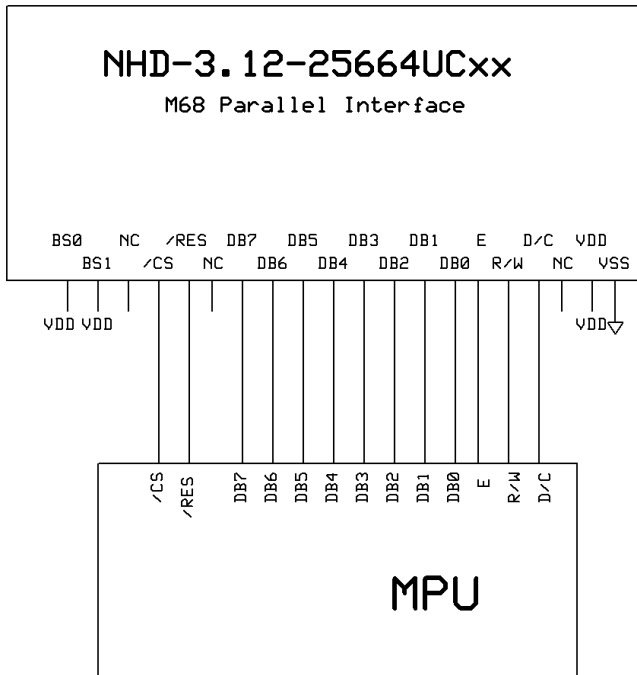

Electrical Characteristics

Item	Symbol	Condition	Min.	Typ.	Max.	Unit
Operating Temperature Range	Top	Absolute Max	-40	-	+85	°C
Storage Temperature Range	Tst	Absolute Max	-40	-	+90	°C
Supply Voltage	VDD	-	-	3.0	3.3	V
Supply Current (logic)	IDD	Ta=25°C, VDD=3.0V	-	5	6	mA
Supply Current (display)	ICC	50% ON, VDD=3.0V	-	155	165	mA
		100% ON, VDD=3.0V	-	250	265	mA
Sleep Mode Current	IDD+ICCSLEEP	-	-	-	110	μA
“H” Level input	Vih	-	0.8*VDD	-	VDD	V
“L” Level input	Vil	-	VSS	-	0.2*VDD	V
“H” Level output	Voh	-	0.9*VDD	-	VDD	V
“L” Level output	Vol	-	VSS	-	0.1*VDD	V

Optical Characteristics

Item	Symbol	Condition	Min.	Typ.	Max.	Unit
Optimal Viewing Angles	Top		-	80	-	°
	Bottom		-	80	-	°
	Left		-	80	-	°
	Right		-	80	-	°
Contrast Ratio	Cr	-	2000:1	-	-	-
Response Time	Rise	Tr	-	10	-	us
	Fall	Tf	-	10	-	us
Brightness	-	50% checkerboard	60	80	-	cd/m ²
Lifetime	-	Ta=25°C, 50% checkerboard	10,000	-	-	Hrs

Note: Lifetime at typical temperature is based on accelerated high-temperature operation. Lifetime is tested at average 50% pixels on and is rated as Hours until **Half-Brightness**. The Display OFF command can be used to extend the lifetime of the display.

Luminance of active pixels will degrade faster than inactive pixels. Residual (burn-in) images may occur. To avoid this, every pixel should be illuminated uniformly.

Built-in SSD1322 controller Instruction Table

Instruction	Code										Description	RESET value	
	D/C	HEX	DB7	DB6	DB5	DB4	DB3	DB2	DB1	DB0			
Enable Grayscale Table	0	00	0	0	0	0	0	0	0	0	0	Enable the Grayscale table settings. (see command 0xB8)	
Set Column Address	0	15	0	0	0	1	0	1	0	1	Set column start and end address	0 119d	
	1	A[6:0]	*	A6	A5	A4	A3	A2	A1	A0	A[6:0]: Column start address. Range: 0-119d		
	1	B[6:0]	*	B6	B5	B4	B3	B2	B1	B0	B[6:0]: Column end address. Range: 0-119d		
Write RAM Command	0	5C	0	1	0	1	1	1	0	0	Enable MCU to write Data into RAM		
Read RAM Command	0	5D	0	1	0	1	1	1	0	1	Enable MCU to read Data from RAM		
Set Row Address	0	75	0	1	1	1	0	1	0	1	Set row start and end address	0 127d	
	1	A[6:0]	*	A6	A5	A4	A3	A2	A1	A0	A[6:0]: Row start address. Range: 0-127d		
	1	B[6:0]	*	B6	B5	B4	B3	B2	B1	B0	B[6:0]: Row end address. Range: 0-127d		
Set Remap	0	A0	1	0	1	0	0	0	0	0	A[0] = 0; Horizontal Address Increment	0	
	1	A[5:0]	0	0	A5	A4	0	A2	A1	A0	A[0] = 1; Vertical Address Increment	0	
	1	B[4]	*	*	0	B4	0	0	0	1	A[1] = 0; Disable Column Address remap A[1] = 1; Enable Column Address remap A[2] = 0; Disable Nibble remap A[2] = 1; Enable Nibble remap A[4] = 0; Scan from COM0 to COM[N-1] A[4] = 1; Scan from COM[N-1] to COM0 A[5] = 0; Disable COM split Odd/Even A[5] = 1; Enable COM split Odd/Even B[4] = 0; Disable Dual COM mode B[4] = 1; Enable Dual COM mode Note: A[5] must be 0 if B[4] is 1.	0 0 0 0 0 0	
Set Display Start Line	0	A1	1	0	1	0	0	0	0	1	Set display RAM display start line register from 0-127.	0	
	1	A[6:0]	*	A6	A5	A4	A3	A2	A1	A0			
Set Display Offset	0	A2	1	0	1	0	0	0	1	0	Set vertical shift by COM from 0~127.	0	
	1	A[6:0]	*	A6	A5	A4	A3	A2	A1	A0			
Display Mode	0	A4/A7	1	0	1	0	0	X2	X1	X0	0xA4 = Entire display OFF 0xA5 = Entire display ON, all pixels Grayscale level 15 0xA6 = Normal display 0xA7 = Inverse display	0xA6	
Enable Partial Display	0	A8	1	0	1	0	1	0	0	0	Turns ON partial mode.		
	1	A[6:0]	0	A6	A5	A4	A3	A2	A1	A0	A[6:0] = Address of start row		
	1	B[6:0]	0	B6	B5	B4	B3	B2	B1	B0	B[6:0] = Address of end row (B[6:0] > A[6:0])		

Exit Partial Display	0	A9	1	0	1	0	1	0	0	1	Exit Partial Display mode	
Function Selection	0	AB	1	0	1	0	1	0	1	1	A[0] = 0; External VDD	1
	1	A[0]	0	0	0	0	0	0	0	A0	A[0] = 1; Internal VDD regulator	
Set Sleep Mode ON/OFF	0	AE~AF	1	0	1	0	1	1	1	X0	0xAE = Sleep Mode ON (display OFF) 0xAF = Sleep Mode OFF (display ON)	
Set Phase Length	0	B1	1	0	1	1	0	0	0	1	A[3:0] = P1. Phase 1 period of 5-31 DCLK clocks	9
	1	A[7:0]	A7	A6	A5	A4	A3	A2	A1	A0	A[7:4] = P2. Phase 2 period of 3-15 DCLK clocks	7
Set Display Clock Divide Ratio / Oscillator Frequency	0	B3	1	0	1	1	0	0	1	1	A[3:0] = 0000; divide by 1	0
	1	A[7:0]	A7	A6	A5	A4	A3	A2	A1	A0	A[3:0] = 0001; divide by 2 A[3:0] = 0010; divide by 4 A[3:0] = 0011; divide by 8 A[3:0] = 0100; divide by 16 A[3:0] = 0101; divide by 32 A[3:0] = 0110; divide by 64 A[3:0] = 0111; divide by 128 A[3:0] = 1000; divide by 256 A[3:0] = 1001; divide by 512 A[3:0] = 1010; divide by 1024 A[3:0] >= 1011; invalid A[7:4] = Set the Oscillator Frequency. Frequency increases with the value of A[7:4]. Range 0000b~1111b.	
Set GPIO	0	B5	1	0	1	1	0	1	0	1	A[1:0] = 00; GPIO0 input disabled	10b
	1	A[3:0]	*	*	*	*	A3	A2	A1	A0	A[1:0] = 01; GPIO0 input enabled A[1:0] = 10; GPIO0 output LOW A[1:0] = 11; GPIO0 output HIGH A[3:2] = 00; GPIO1 input disabled A[3:2] = 01; GPIO1 input enabled A[3:2] = 10; GPIO1 output LOW A[3:2] = 11; GPIO1 output HIGH	
Set Second Precharge Period	0	B6	1	0	1	1	0	1	1	0	Sets the second precharge period	1000b
	1	A[3:0]	*	*	*	*	A3	A2	A1	A0	A[3:0] = DCLKs	
Set Grayscale Table	0	B8	1	0	1	1	1	0	0	0	Sets the gray scale pulse width in units of DCLK. Range 0-180d.	
	1	A1[7:0]	A1₇	A1₆	A1₅	A1₄	A1₃	A1₂	A1₁	A1₀	A1[7:0] = Gamma Setting for GS1	
	1	A2[7:0]	A2₇	A2₆	A2₅	A2₄	A2₃	A2₂	A2₁	A2₀	A2[7:0] = Gamma Setting for GS2	
	1	
	1	
	1	
	1	A14[7:0]	A14₇	A14₆	A14₅	A14₄	A14₃	A14₂	A14₁	A14₀	A14[7:0] = Gamma Setting for GS14	
	1	A15[7:0]	A15₇	A15₆	A15₅	A15₄	A15₃	A15₂	A15₁	A15₀	A15[7:0] = Gamma Setting for GS15	
Select Default	0	B9	1	0	1	1	1	0	0	1	Sets Linear Grayscale table	

Linear Gray Scale Table												GSO pulse width = 0 GSO pulse width = 0 GSO pulse width = 8 GSO pulse width = 16 . . . GSO pulse width = 104 GSO pulse width = 112	
Set Precharge Voltage	0 1	BB A[4:0]	1 *	0 *	1 *	1 A4	1 A3	0 A2	1 A1	1 A0	Set precharge voltage level. A[4:0] = 0x00; 0.20*VCC . . A[4:0] = 0x3E; 0.60*VCC	0x17	
Set VCOMH Voltage	0 1	BE A[3:0]	1 *	0 *	1 *	1 *	1 A3	1 A2	1 A1	0 A0	Sets the VCOMH voltage level A[3:0] = 0x00; 0.72*VCC . . A[3:0] = 0x04; 0.8*VCC . . A[3:0] = 0x07; 0.86*VCC	0x04	
Set Contrast Control	0 1	C1 A[7:0]	1 A7	1 A6	0 A5	0 A4	0 A3	0 A2	0 A1	1 A0	Double byte command to select 1 out of 256 contrast steps. Contrast increases as the value increases.	0x7F	
Master Contrast Control	0 1	C7 A[3:0]	1 *	1 *	0 *	0 *	0 A3	1 A2	1 A1	1 A0	A[3:0] = 0x00; Reduce output for all colors to 1/16 A[3:0] = 0x01; Reduce output for all colors to 2/16 . . A[3:0] = 0x0E; Reduce output for all colors to 15/16 A[3:0] = 0x0F; no change	0x0f	
Set Multiplex Ratio	0 1	CA A[6:0]	1 *	1 A6	0 A5	0 A4	1 A3	0 A2	1 A1	0 A0	Set MUX ratio to N+1 MUX N=A[6:0]; from 16MUX to 128MUX (0 to 14 are invalid)	127d	
Set Command Lock	0 1	FD A[2]	1 0	1 0	1 0	1 1	1 0	1 A2	0 1	1 0	A[2] = 0; Unlock OLED to enable commands A[2] = 1; Lock OLED from entering commands	0x12	

For detailed instruction information, see datasheet: http://www.newhavendisplay.com/app_notes/SSD1322.pdf

MPU Interface

For detailed timing information, see datasheet: http://www.newhavendisplay.com/app_notes/SSD1322.pdf

6800-MPU Parallel Interface

The parallel interface consists of 8 bi-directional data pins, R/W, D/C, E, and /CS.

A LOW on R/W indicates write operation, and HIGH on R/W indicates read operation.

A LOW on D/C indicates "Command" read or write, and HIGH on D/C indicates "Data" read or write.

The E input serves as data latch signal, while /CS is LOW. Data is latched at the falling edge of E signal.

Function	E	R/W	/CS	D/C
Write Command	↓	0	0	0
Read Status	↓	1	0	0
Write Data	↓	0	0	1
Read Data	↓	1	0	1

8080-MPU Parallel Interface

The parallel interface consists of 8 bi-directional data pins, /RD, /WR, D/C, and /CS.

A LOW on D/C indicates "Command" read or write, and HIGH on D/C indicates "Data" read or write.

A rising edge of /RS input serves as a data read latch signal while /CS is LOW.

A rising edge of /WR input serves as a data/command write latch signal while /CS is LOW.

Function	/RD	/WR	/CS	D/C
Write Command	1	↑	0	0
Read Status	↑	1	0	0
Write Data	1	↑	0	1
Read Data	↑	1	0	1

Alternatively, /RD and /WR can be kept stable while /CS serves as the data/command latch signal.

Function	/RD	/WR	/CS	D/C
Write Command	1	0	↑	0
Read Status	0	1	↑	0
Write Data	1	0	↑	1
Read Data	0	1	↑	1

Serial Interface (4-wire)

The 4-wire serial interface consists of serial clock SCLK, serial data SDIN, D/C, and /CS.

D0 acts as SCLK and D1 acts as SDIN. D2 should be left open. D3~D7, E, and R/W should be connected to GND.

Function	/RD	/WR	/CS	D/C	D0
Write Command	Tie LOW	Tie LOW	0	0	↑
Write Data	Tie LOW	Tie LOW	0	1	↑

SDIN is shifted into an 8-bit shift register on every rising edge of SCLK in the order of D7, D6,...D0.

D/C is sampled on every eighth clock and the data byte in the shift register is written to the GDRAM or command register in the same clock.

Note: Read is not available in serial mode.

Serial Interface (3-wire)

The 3-wire serial interface consists of serial clock SCLK, serial data SDIN, and /CS.

D0 acts as SCLK and D1 acts as SDIN. D2 should be left open. D3~D7, E, R/W, and D/C should be connected to GND.

Function	/RD	/WR	/CS	D/C	D0
Write Command	Tie LOW	Tie LOW	0	Tie LOW	↑
Write Data	Tie LOW	Tie LOW	0	Tie LOW	↑

SDIN is shifted into an 9-bit shift register on every rising edge of SCLK in the order of D/C, D7, D6,...D0.

D/C (first bit of the sequential data) will determine if the following data byte is written to the Display Data RAM (D/C = 1) or the command register (D/C = 0).

Note: Read is not available in serial mode.

For detailed protocol information, see datasheet: http://www.newhavendisplay.com/app_notes/SSD1322.pdf

Example Initialization Sequence:

```
Set_Command_Lock(0x12);           // Unlock Basic Commands (0x12/0x16)
Set_Display_On_Off(0x00);         // Display Off (0x00/0x01)
Set_Column_Address(0x1C,0x5B);
Set_Row_Address(0x00,0x3F);
Set_Display_Clock(0x91);          // Set Clock as 80 Frames/Sec
Set_Multiplex_Ratio(0x3F);        // 1/64 Duty (0x0F~0x3F)
Set_Display_Offset(0x00);         // Shift Mapping RAM Counter (0x00~0x3F)
Set_Start_Line(0x00);             // Set Mapping RAM Display Start Line (0x00~0x7F)
Set_Remap_Format(0x14);           // Set Horizontal Address Increment
                                   // Column Address 0 Mapped to SEG0
                                   // Disable Nibble Remap
                                   // Scan from COM[N-1] to COM0
                                   // Disable COM Split Odd Even
                                   // Enable Dual COM Line Mode
Set_GPIO(0x00);                   // Disable GPIO Pins Input
Set_Function_Selection(0x01);      // Enable Internal VDD Regulator
Set_Display_Enhancement_A(0xA0,0xFD); // Enable External VSL
Set_Contrast_Current(0x9F);        // Set Segment Output Current
Set_Master_Current(0x0F);          // Set Scale Factor of Segment Output Current Control
//Set_Gray_Scale_Table();           // Set Pulse Width for Gray Scale Table
Set_Linear_Gray_Scale_Table();     //set default linear gray scale table
Set_Phase_Length(0xE2);            // Set Phase 1 as 5 Clocks & Phase 2 as 14 Clocks
Set_Display_Enhancement_B(0x20);   // Enhance Driving Scheme Capability (0x00/0x20)
Set_Precharge_Voltage(0x1F);       // Set Pre-Charge Voltage Level as 0.60*VCC
Set_Precharge_Period(0x08);        // Set Second Pre-Charge Period as 8 Clocks
Set_VCOMH(0x07);                  // Set Common Pins Deselect Voltage Level as 0.86*VCC
Set_Display_Mode(0x02);            // Normal Display Mode (0x00/0x01/0x02/0x03)
Set_Partial_Display(0x01,0x00,0x00); // Disable Partial Display
Set_Display_On_Off(0x01);
```

Quality Information

Test Item	Content of Test	Test Condition	Note
High Temperature storage	Test the endurance of the display at high storage temperature.	+90°C , 240hrs	2
Low Temperature storage	Test the endurance of the display at low storage temperature.	-40°C , 240hrs	1,2
High Temperature Operation	Test the endurance of the display by applying electric stress (voltage & current) at high temperature.	+85°C 240hrs	2
Low Temperature Operation	Test the endurance of the display by applying electric stress (voltage & current) at low temperature.	-40°C , 240hrs	1,2
High Temperature / Humidity Operation	Test the endurance of the display by applying electric stress (voltage & current) at high temperature with high humidity.	+60°C , 90% RH , 240hrs	1,2
Thermal Shock resistance	Test the endurance of the display by applying electric stress (voltage & current) during a cycle of low and high temperatures.	-40°C,30min -> 25°C,5min -> 85°C,30min = 1 cycle 100 cycles	
Vibration test	Test the endurance of the display by applying vibration to simulate transportation and use.	10-22Hz , 15mm amplitude. 22-500Hz, 1.5G 30min in each of 3 directions X,Y,Z	3
Atmospheric Pressure test	Test the endurance of the display by applying atmospheric pressure to simulate transportation by air.	115mbar, 40hrs	3
Static electricity test	Test the endurance of the display by applying electric static discharge.	VS=800V, RS=1.5kΩ, CS=100pF One time	

Note 1: No condensation to be observed.

Note 2: Conducted after 2 hours of storage at 25°C, 0%RH.

Note 3: Test performed on product itself, not inside a container.

Evaluation Criteria:

- 1: Display is fully functional during operational tests and after all tests, at room temperature.
- 2: No observable defects.
- 3: Luminance >50% of initial value.
- 4: Current consumption within 50% of initial value

Precautions for using OLEDs/LCDs/LCMs

See Precautions at www.newhavendisplay.com/specs/precautions.pdf

Warranty Information and Terms & Conditions

http://www.newhavendisplay.com/index.php?main_page=terms

Newhaven Display International, Inc. reserves the right to alter this product or specification at any time without notification.