

# NHD-320240WG-BxTGH-VZ#-3VR

## Graphic Liquid Crystal Display Module

NHD-	Newhaven Display
320240-	320 x 240 Pixels
WG-	Display Type: Graphic
Bx-	Model
T-	White LED Backlight
G-	STN - Gray
H-	Transflective, 6:00 Optimal View, Wide Temperature
VZ#-	Built-in Negative Voltage
3VR-	3.3V Vdd, Frame Ground
	<b>RoHS Compliant</b>

**Newhaven Display International, Inc.**

2511 Technology Drive, Suite 101

Elgin IL, 60124

Ph: 847-844-8795

Fax: 847-844-8796

[www.newhavendisplay.com](http://www.newhavendisplay.com)

[nhtech@newhavendisplay.com](mailto:nhtech@newhavendisplay.com)

[nhsales@newhavendisplay.com](mailto:nhsales@newhavendisplay.com)

## Document Revision History

Revision	Date	Description	Changed by
0	6/7/2007	Initial Release	-
1	3/16/2010	User guide reformat	MC
2	9/2/2010	Mechanical drawing update	MP
3	10/9/2013	Mechanical Drawing, Pin Description, Electrical Characteristics, Timing Characteristics updated Added Jumper Selection	ML

## Functions and Features

- 320 x 240 pixels
- Built-in S1D13700 Controller
- +3.3V power supply
- RoHS Compliant

# Mechanical Drawing

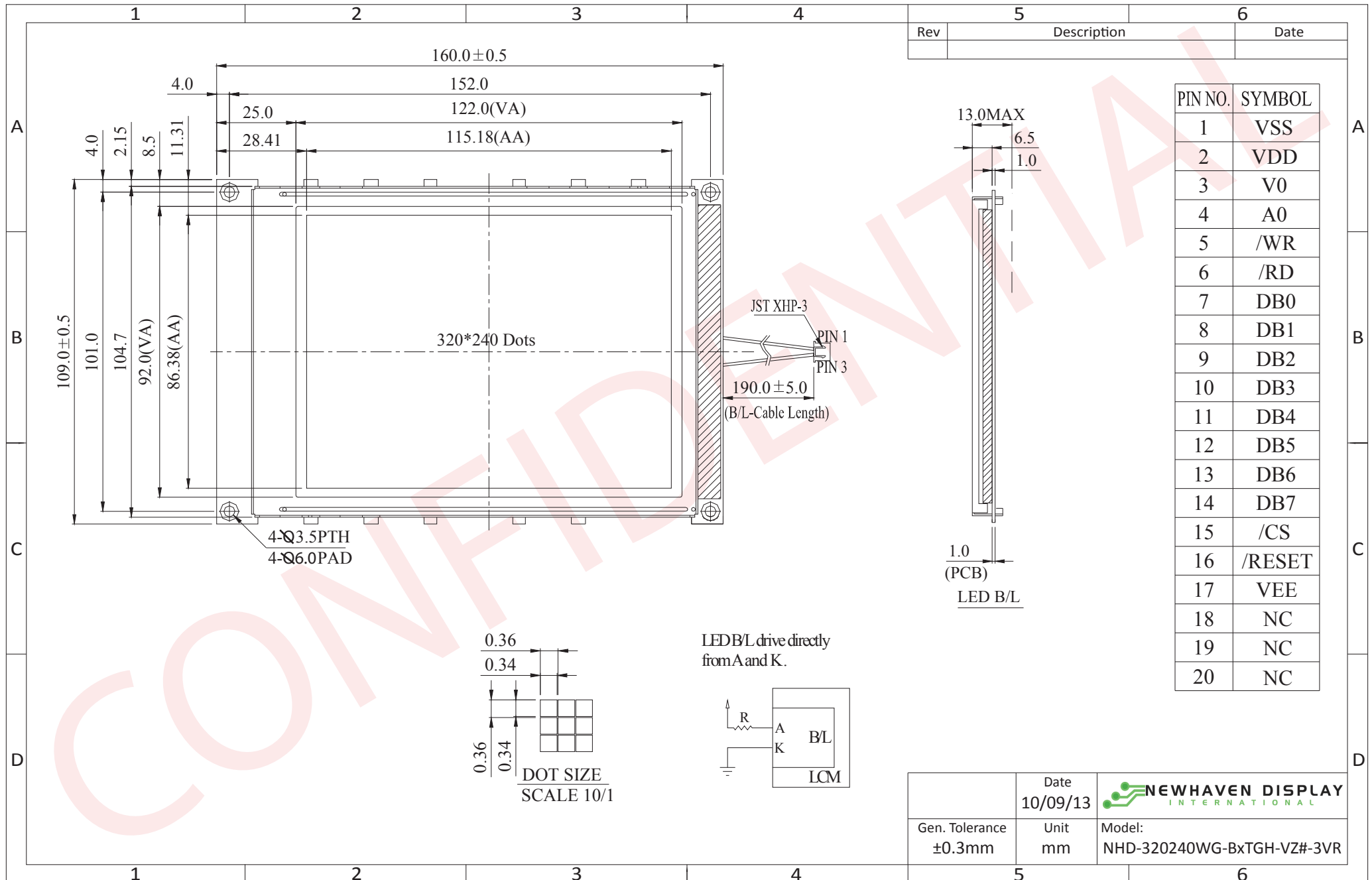

The drawing contained herein is the exclusive property of Newhaven Display International, Inc. and shall not be copied, reproduced, and/or disclosed in any format without permission.

## Pin Description

Pin No.	Symbol	External Connection	Function Description
1	VSS	Power Supply	Ground
2	VDD	Power Supply	Supply Voltage (+3.3V)
3	V0	Adj Power Supply	Adj. Power Supply for contrast (approx. -18.8V)
4	A0	MPU	Register Select signal. A0=0: Command, A0=1: Data
5	/WR R/W	MPU	8080: Active LOW Write signal 6800: Read/Write select signal, R/W=1: Read R/W=0: Write
6	/RD E	MPU	8080: Active LOW Read signal 6800: Operation Enable signal. Falling edge triggered.
7-14	DB0-DB7	MPU	8-bit bi-directional data bus
15	/CS	MPU	Active LOW Chip Select signal
16	/RESET	MPU	Active LOW Reset signal
17	VEE	Power Supply	Negative voltage output (-25V)
18	NC	-	No Connect
19	NC	-	No Connect
20	NC	-	No Connect

**Recommended LCD connector:** 1.0mm pitch, 20-pos FFC connector

**Backlight connector:** JST p/n: XHP-3

**Mates with:** JST p/n: B 3B-XH-A

## Wiring Diagram

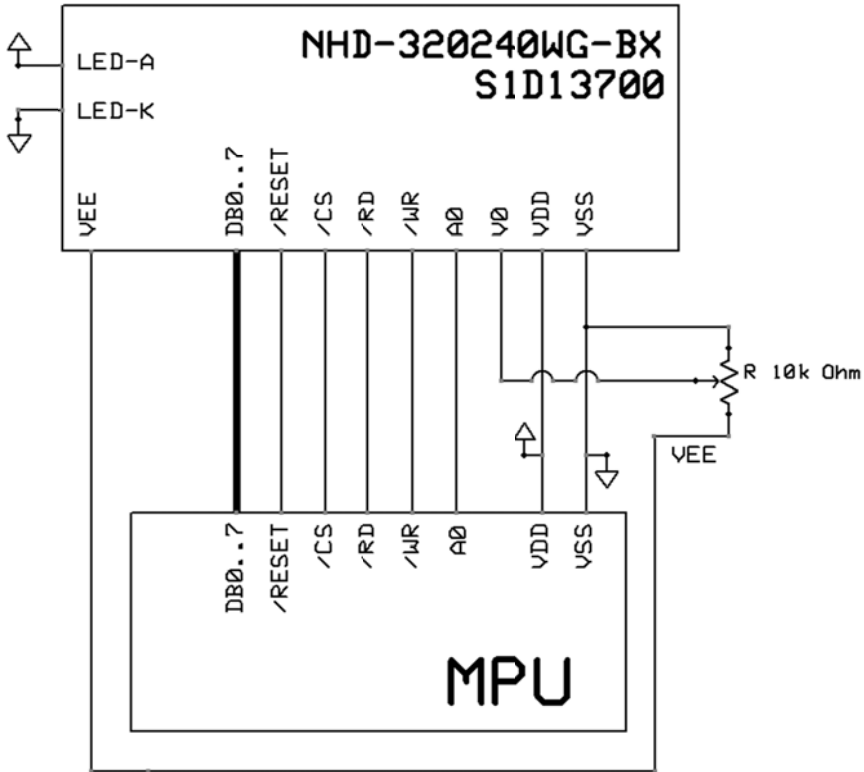

## Jumper Selection

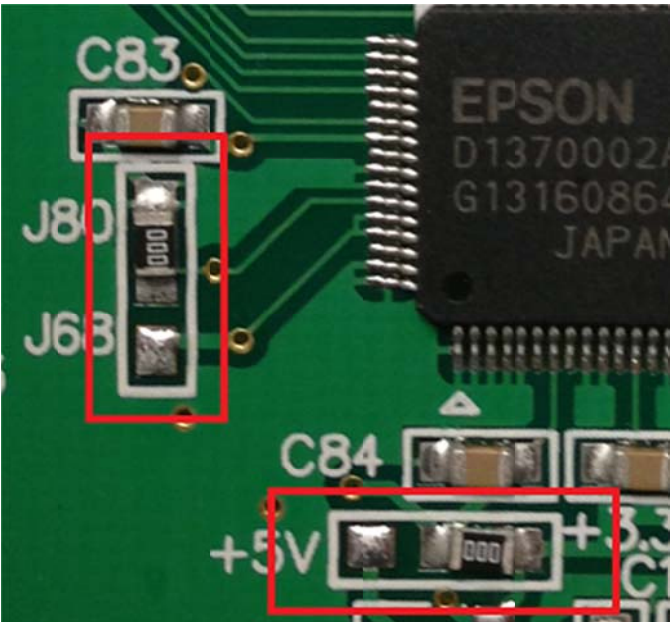

Note: This display is pre-configured for 3.3V and 8080 mode.

## Electrical Characteristics

Item	Symbol	Condition	Min.	Typ.	Max.	Unit
Operating Temperature Range	Top	Absolute Max	-20	-	+70	°C
Storage Temperature Range	Tst	Absolute Max	-30	-	+80	°C
Supply Voltage	VDD	-	3.0	3.3	3.5	V
Supply Current	IDD	Ta=25°C, VDD=5.0V	65.0	75.0	85.0	mA
Supply for LCD (contrast)	VDD-VLCD	Ta=25°C	20.0	21.8	24.1	V
"H" Level input	VIH	-	0.5*VDD	-	VDD	V
"L" Level input	VIL	-	VSS	-	0.2*VDD	V
"H" Level output	VOH	-	VDD-0.4	-	VDD	V
"L" Level output	VOL	-	VSS	-	0.4	V
Backlight Supply Voltage	VLED	-	3.4	3.5	3.6	V
Backlight Supply Current	ILED	VLED=3.5V	120	160	180	mA

## Optical Characteristics

Item	Symbol	Condition	Min.	Typ.	Max.	Unit
Viewing Angle - Top	-	Cr ≥ 3	-	20	-	°
Viewing Angle - Bottom	-		-	40	-	°
Viewing Angle - Left	-		-	30	-	°
Viewing Angle - Right	-		-	30	-	°
Contrast Ratio	Cr	-	-	3	-	-
Response Time (rise)	Tr	-	-	200	300	ms
Response Time (fall)	Tf	-	-	150	200	ms

## Controller Information

Built-in S1D13700 controller.

Please download specification at [http://www.newhavendisplay.com/app\\_notes/S1D13700.pdf](http://www.newhavendisplay.com/app_notes/S1D13700.pdf)

# Table of Commands

<b>REG[01h] Horizontal Character Size Register</b>							
Address = 8001h    Default = 00h							Read/Write
MOD	n/a			Horizontal Character Size bits 3-0			
7	6	5	4	3	2	1	0
<b>REG[02h] Vertical Character Size Register</b>							
Address = 8002h    Default = 00h							Read/Write
n/a			Vertical Character Size bits 3-0				
7	6	5	4	3	2	1	0
<b>REG[03h] Character Bytes Per Row Register</b>							
Address = 8003h    Default = 00h							Read/Write
Character Bytes Per Row bits 7-0							
7	6	5	4	3	2	1	0
<b>REG[04h] Total Character Bytes Per Row Register</b>							
Address = 8004h    Default = 00h							Read/Write
Total Character Bytes Per Row bits 7-0							
7	6	5	4	3	2	1	0
<b>REG[05h] Frame Height Register</b>							
Address = 8005h    Default = 00h							Read/Write
Frame Height bits 7-0							
7	6	5	4	3	2	1	0
<b>REG[06h] Horizontal Address Range Register 0</b>							
Address = 8006h    Default = 00h							Read/Write
Horizontal Address Range bits 7-0							
7	6	5	4	3	2	1	0
<b>REG[07h] Horizontal Address Range Register 1</b>							
Address = 8007h    Default = 00h							Read/Write
Horizontal Address Range bits 15-8							
7	6	5	4	3	2	1	0
<b>REG[08h] Power Save Mode Register</b>							
Address = 8008h    Default = 01h							Read/Write
n/a						Power Save Mode Enable	
7	6	5	4	3	2	1	0
<b>REG[09h] Display Enable Register</b>							
Address = 8009h    Default = 00h							Read/Write
n/a						Display Enable	
7	6	5	4	3	2	1	0
<b>REG[0Ah] Display Attribute Register</b>							
Address = 800Ah    Default = 00h							Read/Write
SAD3 Attribute bits 1-0		SAD2 Attribute bits 1-0		SAD1 Attribute bits 1-0		Cursor Attribute bits 1-0	
7	6	5	4	3	2	1	0
<b>REG[0Bh] Screen Block 1 Start Address Register 0</b>							
Address = 800Bh    Default = 00h							Read/Write
Screen Block 1 Start Address bits 7-0 (LSB)							
7	6	5	4	3	2	1	0
<b>REG[0Ch] Screen Block 1 Start Address Register 1</b>							
Address = 800Ch    Default = 00h							Read/Write
Screen Block 1 Start Address bits 15-8 (MSB)							
7	6	5	4	3	2	1	0
<b>REG[0Dh] Screen Block 1 Size Register</b>							
Address = 800Dh    Default = 00h							Read/Write
Screen Block 1 Size bits 7-0							
7	6	5	4	3	2	1	0

<b>REG[0Eh] Screen Block 2 Start Address Register 0</b>								Read/Write
Address = 800Eh Default = 00h								
Screen Block 2 Start Address bits 7-0 (LSB)								
7	6	5	4	3	2	1	0	
<b>REG[0Fh] Screen Block 2 Start Address Register 1</b>								Read/Write
Address = 800Fh Default = 00h								
Screen Block 2 Start Address bits 15-8 (MSB)								
7	6	5	4	3	2	1	0	
<b>REG[10h] Screen Block 2 Size Register</b>								Read/Write
Address = 8010h Default = 00h								
Screen Block 2 Size bits 7-0								
7	6	5	4	3	2	1	0	
<b>REG[11h] Screen Block 3 Start Address Register 0</b>								Read/Write
Address = 8011h Default = 00h								
Screen Block 3 Start Address bits 7-0 (LSB)								
7	6	5	4	3	2	1	0	
<b>REG[12h] Screen Block 3 Start Address Register 1</b>								Read/Write
Address = 8012h Default = 00h								
Screen Block 3 Start Address bits 15-8 (MSB)								
7	6	5	4	3	2	1	0	
<b>REG[13h] Screen Block 4 Start Address Register 0</b>								Read/Write
Address = 8013h Default = 00h								
Screen Block 4 Start Address bits 7-0 (LSB)								
7	6	5	4	3	2	1	0	
<b>REG[14h] Screen Block 4 Start Address Register 1</b>								Read/Write
Address = 8014h Default = 00h								
Screen Block 4 Start Address bits 15-8 (MSB)								
7	6	5	4	3	2	1	0	
<b>REG[15h] Cursor Width Register</b>								Read/Write
Address = 8015h Default = 00h								
n/a				Cursor Width bits 3-0				
7	6	5	4	3	2	1	0	
<b>REG[16h] Cursor Height Register</b>								Read/Write
Address = 8016h Default = 00h								
Cursor Mode	n/a			Cursor Height bits 3-0				
7	6	5	4	3	2	1	0	
<b>REG[17h] Cursor Shift Direction Register</b>								Read/Write
Address = 8017h Default = 00h								
n/a					Cursor Shift Direction bits 1-0			
7	6	5	4	3	2	1	0	
<b>REG[18h] Overlay Register</b>								Read/Write
Address = 8018h Default = 00h								
n/a			3 Layer Overlay Select	Screen Block 3 Display Mode	Screen Block 1 Display Mode	Layer Composition Method bits 1-0		
7	6	5	4	3	2	1	0	
<b>REG[19h] Character Generator RAM Start Address Register 0</b>								Read/Write
Address = 8019h Default = 00h								
CGRAM Start Address bits 7-0 (LSB)								
7	6	5	4	3	2	1	0	
<b>REG[1Ah] Character Generator RAM Start Address Register 1</b>								Read/Write
Address = 801Ah Default = 00h								
CGRAM Start Address bits 15-8 (MSB)								
7	6	5	4	3	2	1	0	
<b>REG[1Bh] Horizontal Pixel Scroll Register</b>								Read/Write
Address = 801Bh Default = 00h								
n/a				Horizontal Pixel Scroll bits 2-0				
7	6	5	4	3	2	1	0	



<b>REG[1Ch] Cursor Write Register 0</b>								Write Only	
Address = 801Ch    Default = 00h									
Cursor Write bits 7-0 (LSB)									
7	6	5	4	3	2	1	0		
<b>REG[1Dh] Cursor Write Register 1</b>								Write Only	
Address = 801Dh    Default = 00h									
Cursor Write bits 15-8 (MSB)									
7	6	5	4	3	2	1	0		
<b>REG[1Eh] Cursor Read Register 0</b>								Read Only	
Address = 801Eh    Default = 00h									
Cursor Read bits 7-0 (LSB)									
7	6	5	4	3	2	1	0		
<b>REG[1Fh] Cursor Read Register 1</b>								Read Only	
Address = 801Fh    Default = 00h									
Cursor Read bits 15-8 (MSB)									
7	6	5	4	3	2	1	0		
<b>REG[20h] Bit-Per-Pixel Select Register</b>								Read/Write	
Address = 8020h    Default = 00h									
n/a								Bit-Per-Pixel Select bits 1-0	
7	6	5	4	3	2	1	0		

# Timing Characteristics

## 8080 Family Bus Interface Timing

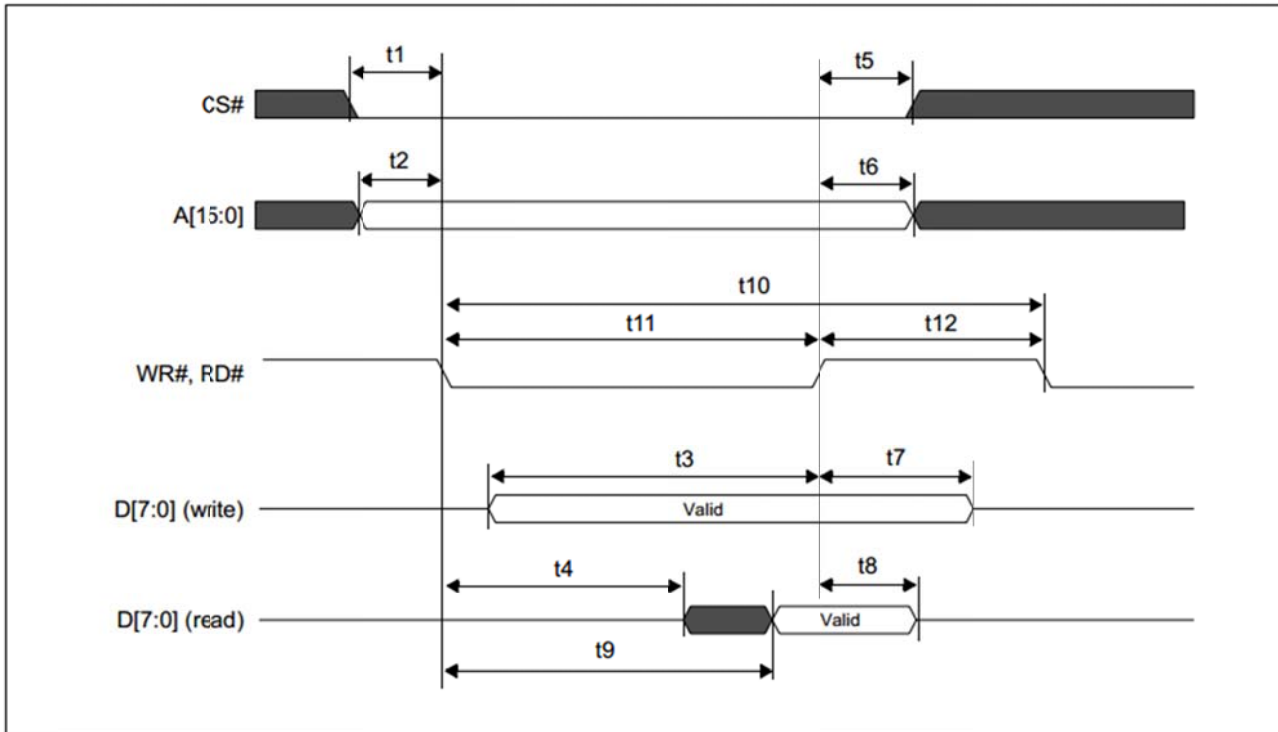

Symbol	Parameter	3.3 Volt		5.0 Volt		Units
		Min	Max	Min	Max	
t1	CS# setup time	5	—	5	—	ns
t2	A[15:0] setup time	5	—	5	—	ns
t3	D[7:0] setup time to WR# rising edge (write cycle)	Note 2	—	Note 2	—	ns
t4	RD# falling edge to D[7:0] driven (read cycle)	3	—	3	—	ns
t5	CS# hold time	7	—	7	—	ns
t6	A[15:0] hold time	7	—	7	—	ns
t7	D[7:0] hold time from WR# rising edge (write cycle)	5	—	5	—	ns
t8	D[7:0] hold time from RD# rising edge (read cycle)	3	14	3	14	ns
t9	RD# falling edge to valid Data (read cycle)	—	Note 3	—	Note 3	ns
t10	RD#, WR# cycle time	Note 4	—	Note 4	—	ns
t11	RD#, WR# pulse active time	5	—	5	—	Ts
t12	RD#, WR# pulse inactive time	Note 5	—	Note 5	—	ns

1. Ts = System clock period
2. t3min = 2Ts + 5
3. t9max = 4Ts + 18 (for 3.3V)  
= 4Ts + 20 (for 5.0V)
4. t10min = 6Ts (for a read cycle followed by a read or write cycle)  
= 7Ts + 2 (for a write cycle followed by a write cycle)  
= 10Ts + 2 (for a write cycle followed by a read cycle)
5. t12min = 1Ts (for a read cycle followed by a read or write cycle)  
= 2Ts + 2 (for a write cycle followed by a write cycle)  
= 5Ts + 2 (for a write cycle followed by a read cycle)

## 6800 Family Bus Interface Timing

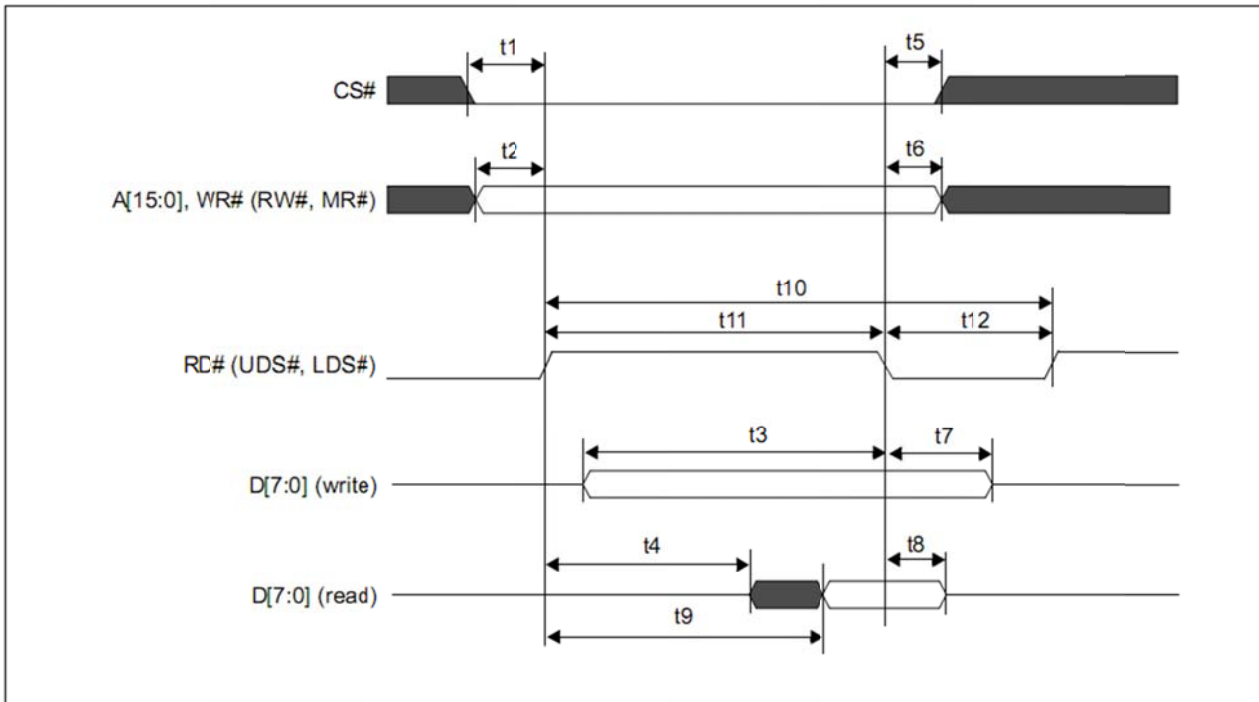

Symbol	Parameter	3.3 Volt		5.0 Volt		Units
		Min	Max	Min	Max	
t1	CS# setup time	5	—	5	—	ns
t2	A[15:0] setup time	5	—	5	—	ns
t3	D[7:0] setup time to RD# falling edge (write cycle)	Note 2	—	Note 2	—	ns
t4	RD# rising edge to D[7:0] driven (read cycle)	3	—	3	—	ns
t5	CS# hold time	7	—	7	—	ns
t6	A[15:0] hold time	7	—	7	—	ns
t7	D[7:0] hold time from RD# falling edge (write cycle)	5	—	5	—	ns
t8	D[7:0] hold time from RD# falling edge (read cycle)	2	55	2	55	ns
t9	RD# rising edge to valid Data	—	Note 3	—	Note 3	ns
t10	RD# cycle time	Note 4	—	Note 4	—	ns
t11	RD# pulse active time	5	—	5	—	Ts
t12	RD# pulse inactive time	Note 5	—	Note 5	—	ns

1. Ts = System clock period
2. t3min = 2Ts + 5
3. t9max = 4Ts + 18 (for 3.3V)  
= 4Ts + 20 (for 5.0V)
4. t10min = 6Ts (for a read cycle followed by a read or write cycle)  
= 7Ts + 2 (for a write cycle followed by a write cycle)  
= 10Ts + 2 (for a write cycle followed by a read cycle)
5. t12min = 1Ts (for a read cycle followed by a read or write cycle)  
= 2Ts + 2 (for a write cycle followed by a write cycle)  
= 5Ts + 2 (for a write cycle followed by a read cycle)

## Example Initialization Code

```
//-----  
Sub Writecom  
  Reset P3.0  
  P1 = A  
  Reset P3.1  
  Reset P3.7  
  Set P3.4  
  Reset P3.4  
  Set P3.7  
  Set P3.1  
End Sub  
  
Sub Writedata  
  Set P3.0  
  P1 = A  
  Reset P3.1  
  Reset P3.7  
  Set P3.4  
  Reset P3.4  
  Set P3.7  
  Set P3.1  
End Sub  
  
//-----  
Sub Init  
  Set P3.2  
  Reset P3.6  
  Waitms 10  
  Set P3.6  
  Waitms 100  
  
  A = &H40  
  Call Writecom  
  A = &H30  
  Call Writedata  
  A = &H87  
  Call Writedata  
  A = &H07  
  Call Writedata  
  A = &H27  
  Call Writedata  
  A = &H50  
  Call Writedata  
  A = &HEF  
  Call Writedata  
  A = &H28  
  Call Writedata  
  A = &H00  
  Call Writedata  
  A = &H44  
  Call Writecom  
  A = &H00  
  Call Writedata  
  A = &H00  
  Call Writedata  
  A = &HEF  
  Call Writedata  
  A = &HB0  
  Call Writedata  
  A = &H04  
  Call Writedata  
  
  'A0 = L = Write command  
  'move data to P1  
  'chip select  
  'R/W  
  'E  
  'E  
  'R/W  
  'CS  
  
  'A0 = H = Write data  
  
  'SEL=1 = Motorola 6800 interface  
  'RESET  
  'wait  
  'RESET done  
  'wait  
  
  'system set command  
  'set parameters  
  'horizontal character size=8  
  'vertical character size=8  
  'display addresses per line  
  'total address range per line  
  '240 display lines  
  'virtual address1  
  'virtual address2  
  'scroll  
  'start address1  
  'start address2  
  '240 lines  
  '2nd screen start1  
  '2nd screen start2
```

```

A = &HEF                                '2nd screen 240 lines
Call Writedata
A = &H00                                  '3rd screen address1
Call Writedata
A = &H00                                  '3rd screen address2
Call Writedata
A = &H00                                  '4th screen address1
Call Writedata
A = &H00                                  '4th screen address2
Call Writedata
A = &H5A                                  'hdot scr
Call Writecom
A = &H00                                  'horizontal pixel shift=0
Call Writedata
A = &H5B                                  'overlay
Call Writecom
A = &H00                                  'OR
Call Writedata
A = &H5D                                  'cursor form
Call Writecom
A = &H04                                  '5 pixels
Call Writedata
A = &H86                                  'by 7 pixels
Call Writedata
A = &H4C                                  'cursor direction = right
Call Writecom

Call Clr                                  'clear the screen

A = &H59                                  'disp on/off
Call Writecom
A = &H14                                  'on
Call Writedata
End Sub

```

//-----

## Quality Information

Test Item	Content of Test	Test Condition	Note
High Temperature storage	Endurance test applying the high storage temperature for a long time.	+80°C , 96hrs	2
Low Temperature storage	Endurance test applying the low storage temperature for a long time.	-30°C , 96hrs	1,2
High Temperature Operation	Endurance test applying the electric stress (voltage & current) and the high thermal stress for a long time.	+70°C, 96hrs	2
Low Temperature Operation	Endurance test applying the electric stress (voltage & current) and the low thermal stress for a long time.	-20°C , 96hrs	1,2
High Temperature / Humidity Operation	Endurance test applying the electric stress (voltage & current) and the high thermal with high humidity stress for a long time.	+60°C , 90% RH , 96hrs	1,2
Thermal Shock resistance	Endurance test applying the electric stress (voltage & current) during a cycle of low and high thermal stress.	-20°C,30min -> 25°C,5min -> 70°C,30min = 1 cycle 10 cycles	
Vibration test	Endurance test applying vibration to simulate transportation and use.	10-55Hz , 15mm amplitude. 60 sec in each of 3 directions X,Y,Z For 15 minutes	3
Static electricity test	Endurance test applying electric static discharge.	VS=800V, RS=1.5kΩ, CS=100pF One time	

**Note 1:** No condensation to be observed.

**Note 2:** Conducted after 4 hours of storage at 25°C, 0%RH.

**Note 3:** Test performed on product itself, not inside a container.

## Precautions for using LCDs/LCMs

See Precautions at [www.newhavendisplay.com/specs/precautions.pdf](http://www.newhavendisplay.com/specs/precautions.pdf)

## Warranty Information

See Terms & Conditions at [http://www.newhavendisplay.com/index.php?main\\_page=terms](http://www.newhavendisplay.com/index.php?main_page=terms)