

Specification

To: _____ Co., Ltd.

Name of products
High Sensitivity type Hall Element

Model
NHE 520-HF-6/7

Acceptance of Customer(s) Please send back 1 set of this specification
with your signature for acceptance

Date
5 Sep. 2008

NIPPON CERAMIC CO.,LTD

APPROVED	CHECKED	FACTURE
		

Specification of NHE520-HF-6/7

1. Absolute Maximum Ratings

Item	Symbol	Rating	Unit
Max. Control current	Ic max	40°C current driven	20 mA
Operating temp.	Topr	-40~+110	°C
Storage temp.	Tstg	-40~+125	°C

Note: without restriction resistance, stay within input voltage derating curve envelope

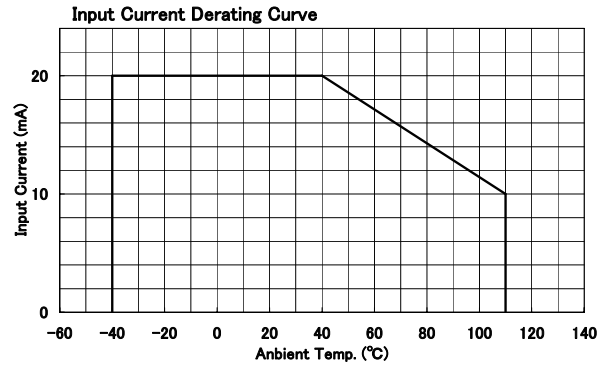
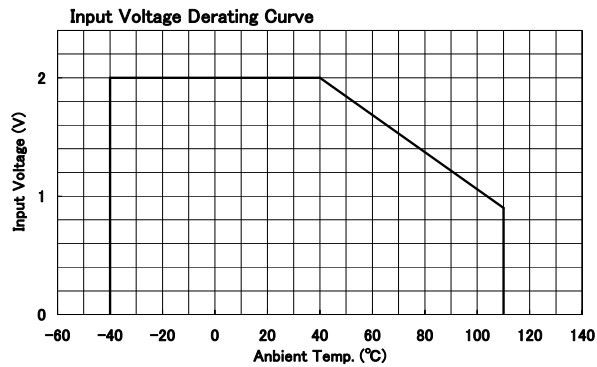

2. Electrical Characteristics

Item	Symbol	Condition	Min	Standard	Max	Unit
Hall voltage	VH	Vc=1V, B=50mT	228		320	mV
Offset voltage	Vo	Vc=1V, B=0mT	-7		+7	mV
Input resistance	Rin	Ic=1mA, B=0mT	240		550	Ω
Output resistance	Rout	Ic=1mA, B=0mT	240		550	Ω
Temp. coeff. of VH	αHI	Average on 0~40°C for 20°C base B=50mT Ic=5mA		-2		%/°C
Temp. coeff. of resistance	βR	Average on 0~40°C for 20°C base B=0mT Ic=0.1mA		-2		%/°C

$$*VH = VHM - Vo$$

$\left[\begin{array}{l} VHM : \text{Measured value of Hall voltage at 50mT} \\ Vo : \text{Offset voltage} \end{array} \right.$

3. Classification of rank for Hall voltage and Printed indication

Classification of rank for Hall voltage

*VH(mV)	Name of Rank	Printing
228~274	6	6
266~320	7	7

Indication of model(Rank)

NHE520-HF- □

(□ is showing name of Rank)

HF: Halogen - Free

Specification of NHE520-HF-6/7

4. Guarantee conditions for mounting mini-mould package

(1) Recommended conditions for soldering the product to the substrate

- 1) Please avoid heating and cooling the main body rapidly.
- 2) Preheating should be done for 2~3 min. at 150~200°C
- 3) Soldering for 5 sec. at 245~260°C is the best condition for soldering (example: reflow).

(2) Soldering method and guaranteed temperature.

1) Soldering Method

Method	Conditions	Temp.
Reflow	Soldering is done in high temp circumstances	MAX260°C 10sec.
Solder dip	Soldering is done in the dipping sink for solder.	MAX260°C 10sec.
Soldering Iron	Repair soldering parts of the lead wire by using the soldering iron.	350°C within 3sec.

2) Range of guaranteed temp.

Reflow

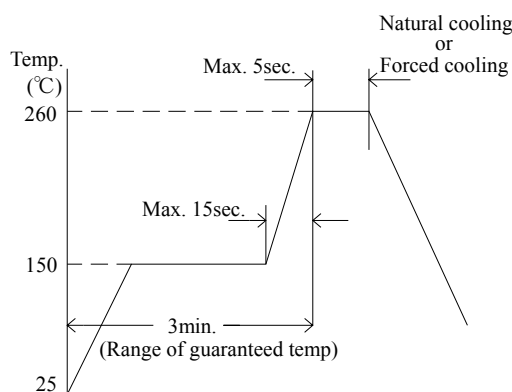

Solder dip

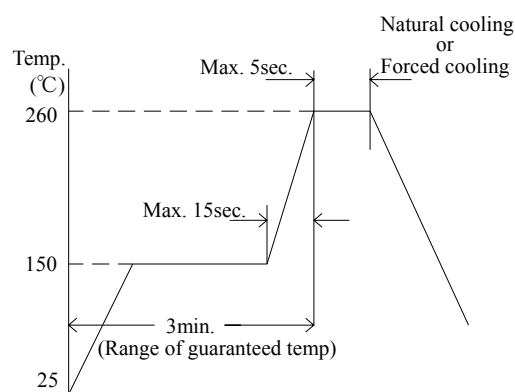

Guaranteed Value (at Highest temp.)

Method	Reflow	Dip
Temp	260°C	260°C
Time	5sec.	5sec.

Specification of NHE520-HF-6/7

5. Description of packing

(1) Structure of taping

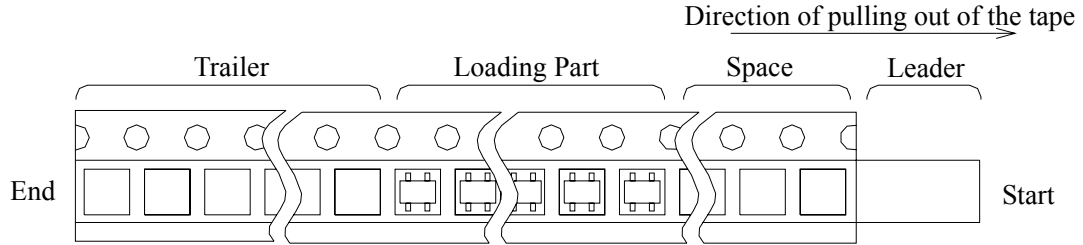

(1)-1 The Hall elements are laid in a tape, and the printed sides of the elements are on the side of cover tape. The long sides of the elements are along the pulling-out direction of the tape. The direction of Hall element itself does not matter.

(1)-2 It is required to leave 4 cm or more space at the beginning and the end of the tape, it is also required to leave 4 cm or more space at the trailer part.

(2) Mechanical strength and handling.

(2)-1 The exfoliating strength of cover tape is 10~90 g.

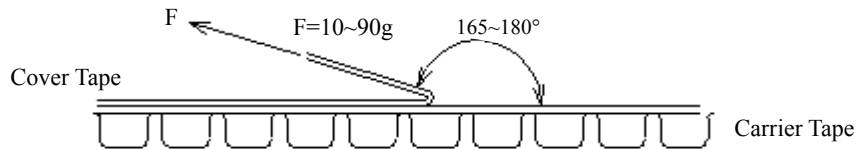

(2)-2 Even though tape is curved by radius 15mm, the product doesn't jump out.

(2)-3 The product doesn't stick to the cover tape.

(2)-4 It shall be stored in the place where the temperature is below 40°C, and humidity below 80%.

It must not be stored where it may be exposed to the direct rays of the sun.

(2)-5 There should not be a missing product in the tape.

(2)-6 There should not be any joint on the tape.

(3) Packing

(3)-1 There are 3,000 pcs of Hall element in 1 reel.

(3)-2 There are 5 reels of reels (15,000pcs) in a case.

(3)-3 There are 6 cases (90,000pcs) in a carton.

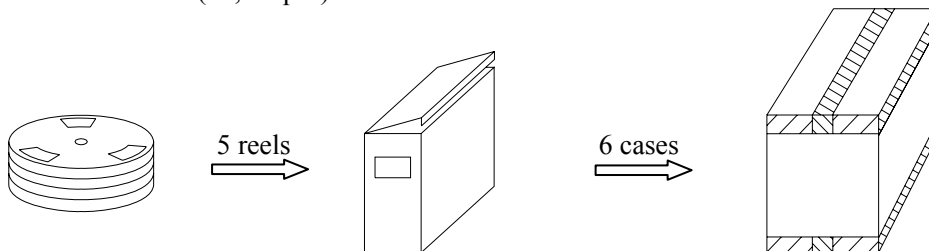

Notes: 5 reels are put in a case vertically.

A case has 5 reels.

A carton has 6 cases.

Specification of NHE520-HF-6/7

6. Outline drawing of Hall Element [Unit: mm]

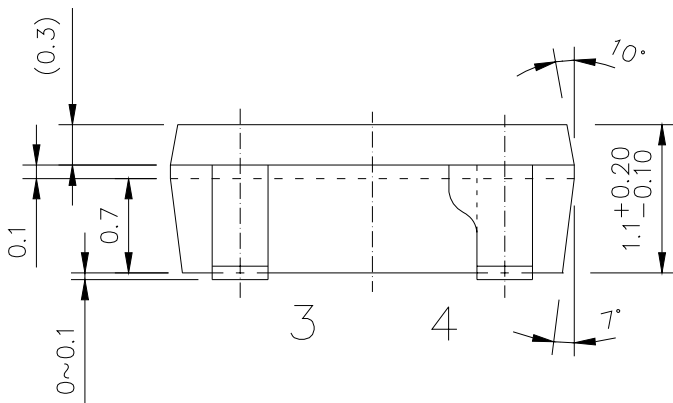
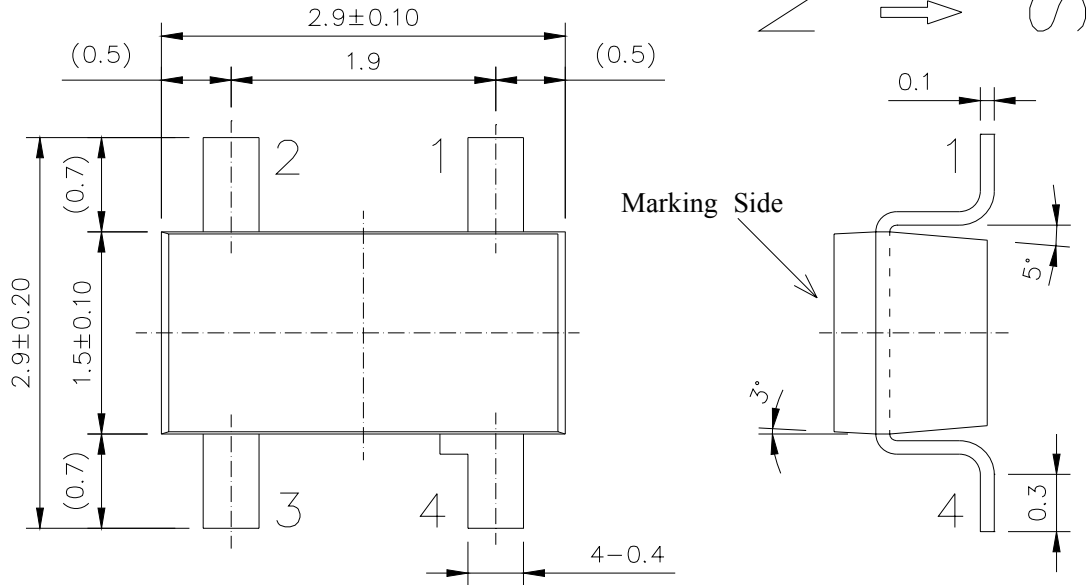

No. of lead terminals

- 1. INPUT (±)
- 2. OUTPUT (±)
- 3. INPUT (∓)
- 4. OUTPUT (∓)

Halogen-free product

7. Marking

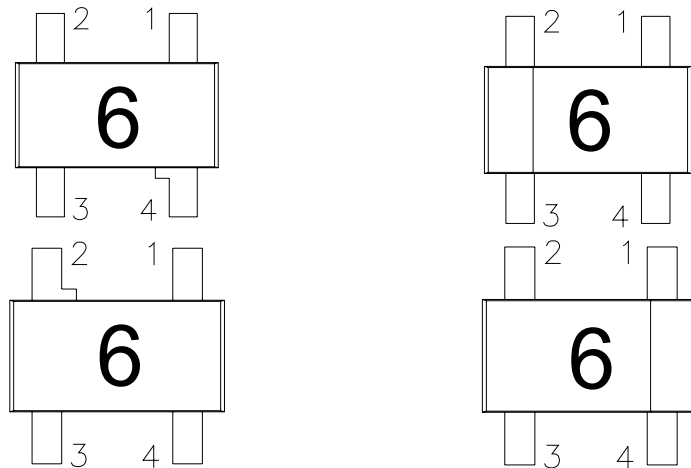

Specification of NHE520-HF-6/7

8. Outline drawing of carrier tape [Unit: mm]

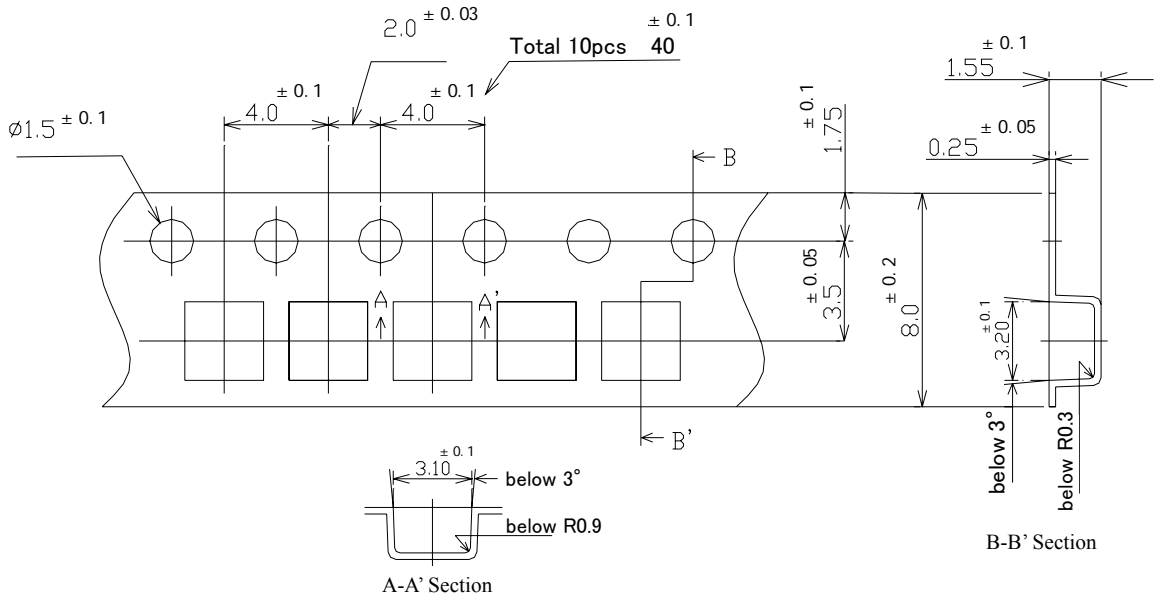

9. Outline drawing of reel [Unit: mm]

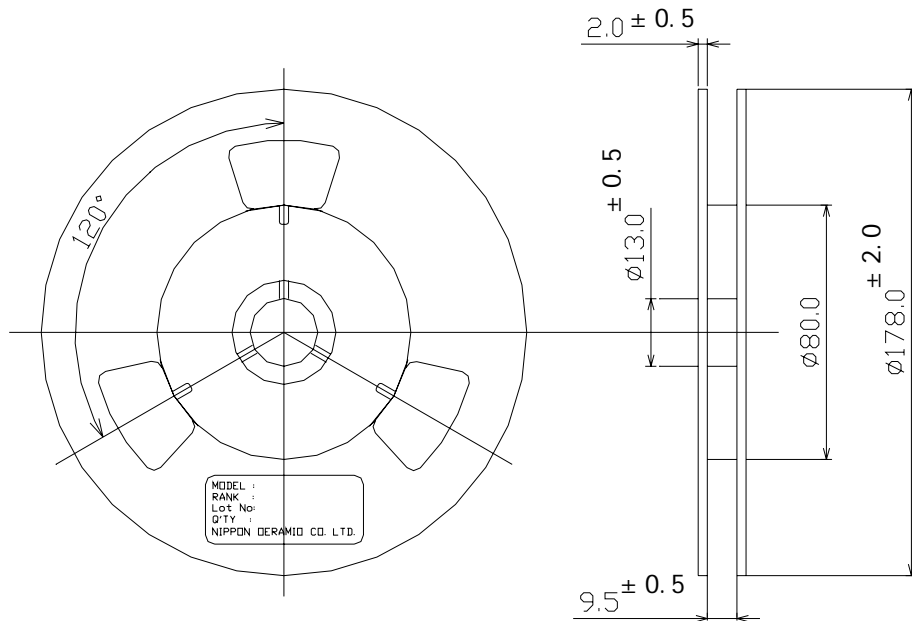

Specification of NHE520-HF-6/7

10. Restoring method of reel

(1) When we discovered a defective product by the appearance inspection, we replace it with a quality product.

(2) Exchange method

(2)-1 The carry tape (three faces) is broken with a knife.

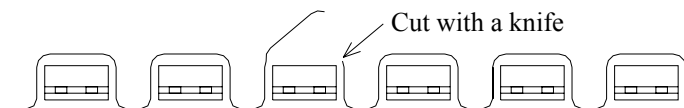

(2)-2 The hall element is replaced.

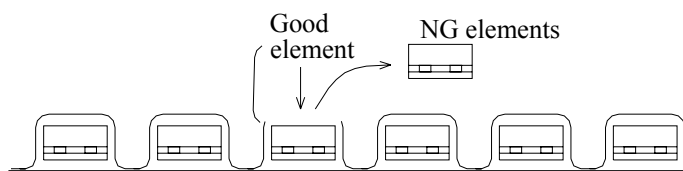

(2)-3 The carry tape is closed, and the break is restored with adhesive.

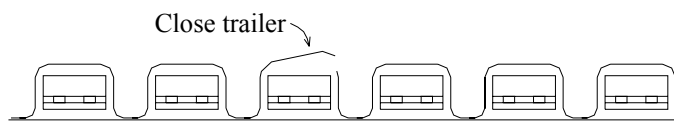

(3) Restoring range

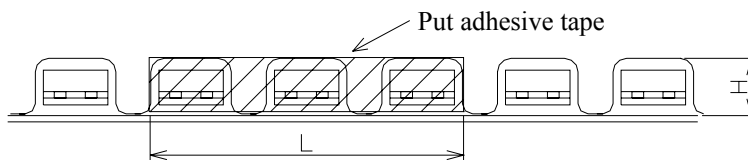

Restoring tape length $L=10.0\sim 12.0\text{mm}$ Restoring tape height $H=1.2\sim 1.5\text{mm}$

Specification of NHE520-HF-6/7

11. Cautions

(1) Attention for storage

Because the products are packed in tapes when shipped, it is required to pay most attention on the Circumstances for the storage of the products, as we mention in the section 5.

If the products are stored under the following circumstances or equivalent circumstances, damage to appearance, defectiveness of characteristics and assembly deterioration may occur.

Please understand the above and store the products with care.

Recommended Circumstance is to keep them in N2-Box.

- a. Circumstances under high temperature, high humidity for long hours.
- b. Circumstances that has corrosive gas, organic gas, acidity and alkalinity background.
- c. Dusty Circumstances.

(2) Attention for mounting

Please follow the matters as we mention in the section 4

(3) Notice

This specification certifies the quality of Hall element itself. The guarantee does not cover the following situations.

- a. When it is inappropriately handled or used in a wrong way by the user.
- b. When it gets additional treatment by others (except for the supplier).
- c. When it meets a situation that Nicera is not able to control such as natural disasters etc .

The guarantee of this specification limits the guarantee to replacing the Hall element itself.

The expenses for exchange and /or the damage caused by the defective or failed products are not covered.

Your understanding and cooperation is highly appreciated.