



Data Device Corporation

1-800-DDC-5757 | 631-567-5600
105 Wilbur Place, Bohemia, NY 11716
service@ddc-web.com | www.ddc-web.com



NHi-1567/68 NHi-15LV67/68 NHi-15133/134 NHi-15LV133/134 +5v/+3.3v Monolithic Mil-Std-1553/1760 Transceivers

Features

- **Dual Transceiver**
- **Totally Independent Channels**
- **Single Power Supply**
- **Short Circuit Tolerant**
- **NHi Proprietary ASIC**
- **Superior Noise Filter**
- **Mac-Air compliant version also available**
- **NHi-15133/134 has higher receiver threshold**

Description

The receivers convert Manchester II bi-phase data into complementary digital outputs. Each receiver has an independent digital enable.

The transmitters convert complementary digital inputs into Manchester II bi-phase data. Each transmitter has an independent digital inhibit.

A coupling transformer interfaces each transceiver to the Stub or Bus.

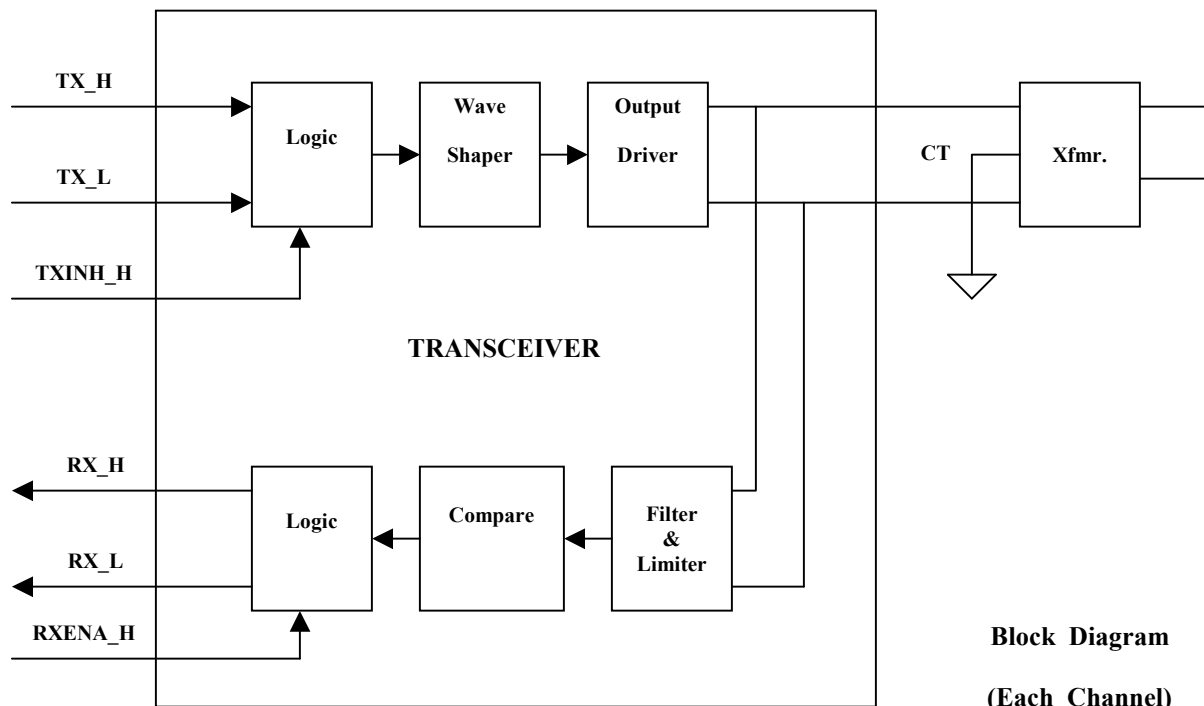

**NHi-15133/134 NHi-15LV133/134 NHi-1567/68 NHi-15LV67/68
+5v/+3.3v Monolithic Mil-Std-1553/1760 Transceivers**

ABSOLUTE MAXIMUM RATINGS

Supply Voltage	Symbol	Min	Max	Units	Notes
Power Supply	Vdd_+5.0	-0.3	+7.0	Vdc	1
Power Supply	Vdd_+3.3	-0.3	+3.9	Vdc	1
Receiver Differential Input Voltage	Vdd_+5.0		15	Vpp	1
Receiver Differential Input Voltage	Vdd_+3.3		12	Vpp	1
Peak Transmitter Current	Ipkmax		1.0	A	
Solder Temperature	Tsold		300	°C	
Storage Temperature	Tstor	-133	+150	°C	
Lead Temperature	Tlead		+300	°C	
Input Zapping	Vzap	2000		Vdc	3
Logic Input Current	Ilgc	-10		uA	2

Notes:

- 1. Vdd referenced to ground.**
- 2. Does not include current through internal pullup/pulldown resistors.**
- 3. As defined for ESDS in method 3015 of Mil-Std-883, Class 2.**
- 4. Guaranteed by design.**

NHi-1567/68**NHi-15133/134****General Electrical Specifications**

PARAMETER	CONDITION	SYM	MIN	TYP	MAX	UNITS	NOTES
Power Supply	75Ω Load On Stub	Vdd	4.75	5.00	5.25	Vdc	
Output Voltage	75Ω Load On Stub	Vout	20	22	24	Vpp	
Standby Current	Not Transmitting; Total Part	Istby		13	17	mA	
Transmitter Current	100% Duty Cycle; One Channel Transmitting; 75Ω Load On Stub	Idd	500		650	mA	
Total Power Dissipation	100% Duty Cycle; One Channel Transmitting; 75Ω Load On Stub	Pd		1.07	1.20	W	
Operating Temperature	Case	Tc	-55		+125	°C	
Thermal Impedance	Junction to Case	θjc			6	°C/W	4
Logic I/O							4
Vin High		Vih	2			V	4
Vin Low		Vil			0.8	V	4
Iin High	Vih = 2.7v	Iih	20		50	uA	4
Iin Low	Vil = 0.4v	Iil	-20		-50	uA	4
Vout High	Ioh = 4ma	Voh	2.3			V	4
Vout Low	Iol = 4ma	Vol			0.4	V	4

Transceiver Electrical Specifications

PARAMETER	CONDITION	SYM	MIN	TYP	MAX	UNITS	NOTES
Rise/Fall Time	Resistive Load On Xfmr, 1553	Tr/Tf	100		250	ns	
	Resistive Load On Xfmr, Mac-Air	Tr/Tf	210		240		
Dynamic Offset	Measured On Stub	Vdo	-250		+250	mV	
Output Noise	On Stub; Not Transmitting	Vno			10	mV	
Output Impedance	On Stub; Not Transmitting	Zo	3K			Ω	4
Input Level	On Stub	Vin			30	Vpp	
Receiver Threshold NHi-1567,68	Referred To Stub		500		650	mV	
Receiver Threshold NHi-15133,134	Referred To Stub	Vthr	660	700	780	mV	
Common Mode Rejection	DC To 2Mhz	Cmrr	40			dB	

NHi-15LV67/68**NHi-15LV133/134****General Electrical Specifications**

PARAMETER	CONDITION	SYM	MIN	TYP	MAX	UNITS	NOTES
Power Supply	75Ω Load On Stub	Vdd	3.15	3.30	3.45	Vdc	
Output Voltage	75Ω Load On Stub	Vout	20	22	24	Vpp	
Standby Current	Not Transmitting; Total Part	Istby		13	17	mA	
Transmitter Current	100% Duty Cycle; One Channel Transmitting; 75Ω Load On Stub	Idd	700		900	mA	
Total Power Dissipation	100% Duty Cycle; One Channel Transmitting; 75Ω Load On Stub	Pd		.840	.920	W	
Operating Temperature	Case	Tc	-55		+125	°C	
Thermal Impedance	Junction to Case	θjc			6	°C/W	4
Logic I/O							4
Vin High		Vih	2			V	4
Vin Low		Vil			0.8	V	4
Iin High	Vih = 2.7v	Iih	20		50	uA	4
Iin Low	Vil = 0.4v	Iil	-20		-50	uA	4
Vout High	Ioh = 4ma	Voh	2.3			V	4
Vout Low	Iol = 4ma	Vol			0.4	V	4

Transceiver Electrical Specifications

PARAMETER	CONDITION	SYM	MIN	TYP	MAX	UNITS	NOTES
Rise/Fall Time	Resistive Load On Xfmr, 1553	Tr/Tf	100		250	ns	
	Resistive Load On Xfmr, Mac-Air	Tr/Tf	210		240		
Dynamic Offset	Measured On Stub	Vdo	-250		+250	mV	
Output Noise	On Stub; Not Transmitting	Vno			10	mV	
Output Impedance	On Stub; Not Transmitting	Zo	3K			Ω	4
Input Level	On Stub	Vin			30	Vpp	
Receiver Threshold NHi-1567,68	Referred To Stub		500		650	mV	
Receiver Threshold NHi-15133,34	Referred To Stub	Vthr	660	700	780	mV	
Common Mode Rejection	DC To 2Mhz	Cmrr	40			dB	

Pin Functions

20 Pin Dip/Fp/Soic Package

Pin	Function	Pin	Function
1	Vdd_A	20	Txin_A_L
2	Bus_A_H	19	Txin_A_H
3	Bus_A_L	18	Txena_A_L
4	Rxena_A_H	17	Rxo_A_H
5	Gnd_A	16	Rxo_A_L
6	Vdd_B	15	Txin_B_L
7	Bus_B_H	14	Txin_B_H
8	Bus_B_L	13	Txena_B_L
9	Rxena_B_H	12	Rxo_B_H
10	Gnd_B	11	Rxo_B_L

44 Pin Chip Scale Package

Pin	Function	Pin	Function
1	N/C	44	N/C
2	Rxena_A_H	43	Bus_A_L
3	Gnd_A	42	Bus_A_L
4	Gnd_A	41	Bus_A_H
5	Gnd_A	40	Bus_A_H
6	Vdd_B	39	Vdd_A
7	Vdd_B	38	Vdd_A
8	Bus_B_H	37	Txin_A_L
9	Bus_B_H	36	Txin_A_H
10	Bus_B_L	35	N/C
11	Bus_B_L	34	N/C
12	N/C	33	N/C
13	N/C	32	N/C
14	N/C	31	Txena_A_L
15	N/C	30	Rxo_A_H
16	Rxena_B_H	29	Rxo_A_L
17	Gnd_B	28	N/C
18	Gnd_B	27	N/C
19	Gnd_B	26	Txin_B_L
20	Rxo_B_L	25	Txin_B_H
21	Rxo_B_H	24	Txena_B_L
22	N/C	23	N/C

Power Supply

Part Number	Vdd
NHi-1567/68/133/134	+5v
NHi-15LV67/68/133/134	+3.3v

Coupling Transformer Turns Ratio

Part Number	Stub	Direct
NHi-1567/68/133/134	1ct : 1.79ct	1ct : 2.5ct
NHi-15LV67/68/133/134	1ct : 2.5ct	1ct : 3.54ct

Receiver Logic

Part Number	Rxena_H	Stub/Bus	Rxo_H	Rxo_L
NHi-1567/133/LV67/133	1	Vthr- <Vpp< +Vthr	0	0
NHi-1567/133/LV67/133	1	Vthr- <Vpp>= +Vthr	1	0
NHi-1567/133/LV67/133	1	Vthr- =>Vpp< +Vthr	0	1
NHi-1567/133/LV67/133	0	X	0	0
NHi-1568/134/LV68/134	1	Vthr- <Vpp< +Vthr	1	1
NHi-1568/134/LV68/134	1	Vthr- <Vpp>= +Vthr	1	0
NHi-1568/134/LV68/134	1	Vthr- =>Vpp< +Vthr	0	1
	0	X	1	1

Transmitter Logic

Txin_H ^[1]	Txin_L ^[1]	Txena_L ^[1]	Stub/Bus
0	0	0	Hi_Z
1	0	0	Vpp
0	1	0	Vpp
1	1	0	Hi_Z
X	X	1	Hi_Z

Note: [1] This input has a weak pull-up resistor to Vcc. The value is 50kΩ to 100kΩ.

NHi-1567/68/133/134

FLAT PACKAGE

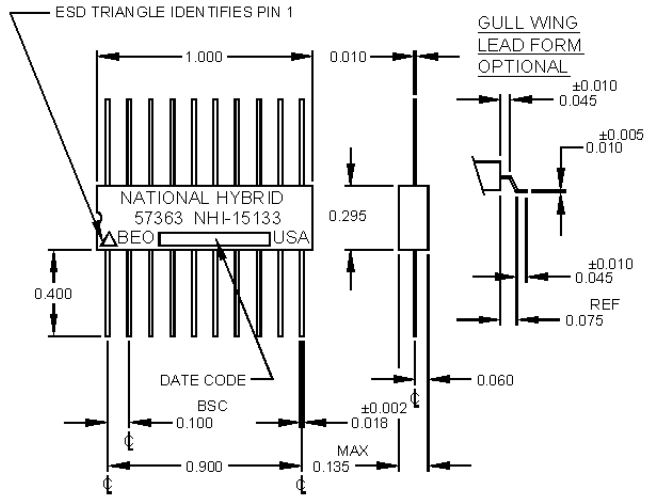

DUAL IN-LINE PACKAGE

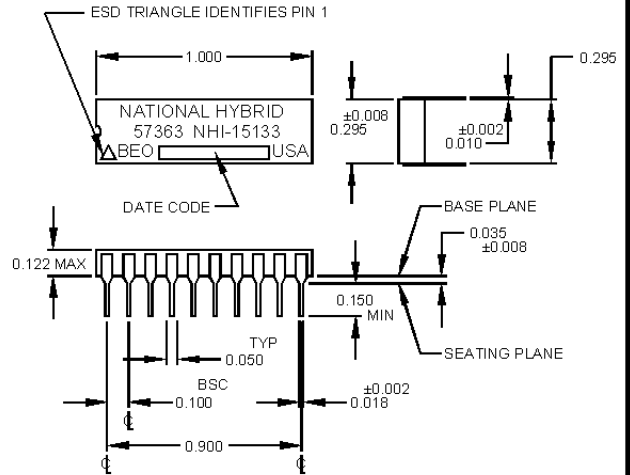

NHi-15LV67/68/133/134

FLAT PACKAGE

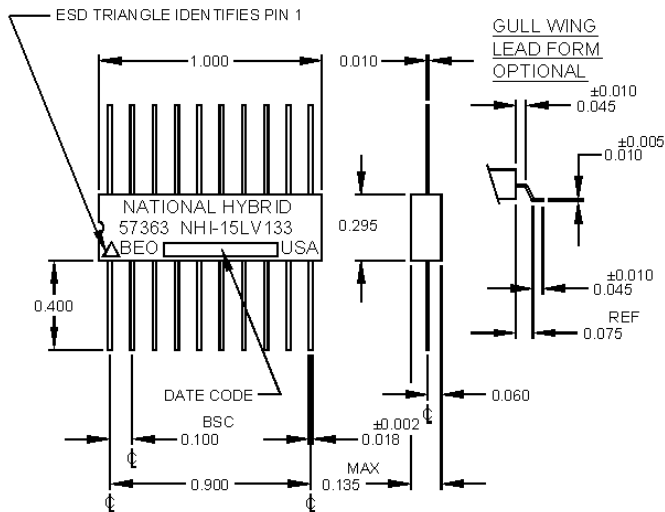

DUAL IN-LINE PACKAGE

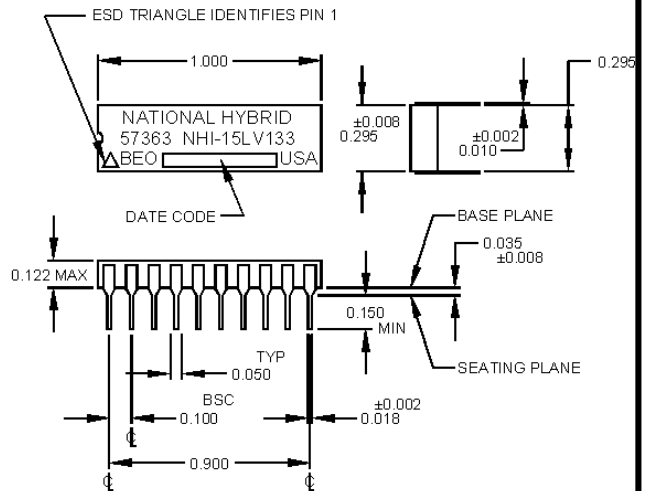

NHi-1567/68/133/134

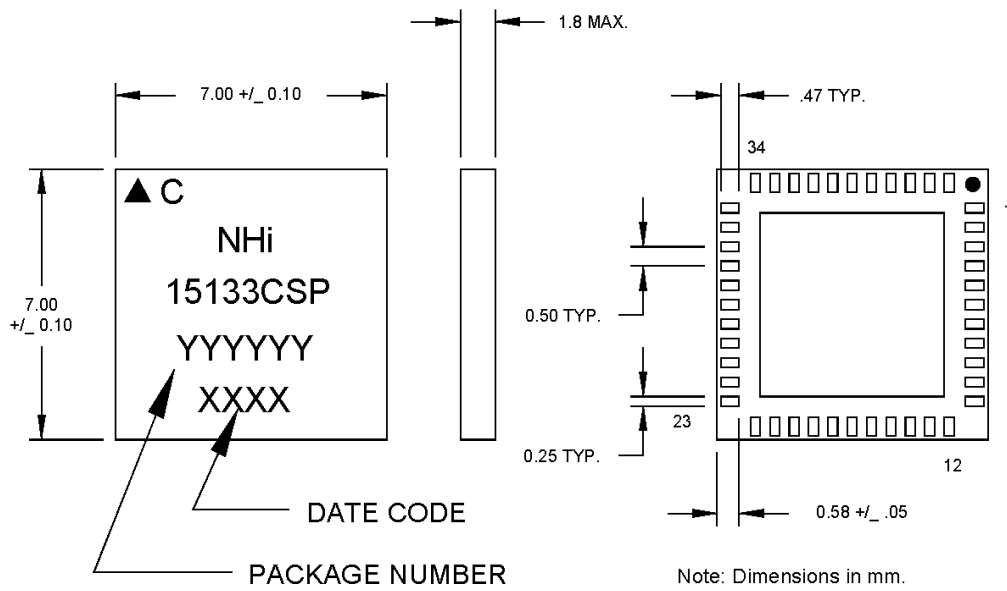

NHi-15LV67/68/133/134

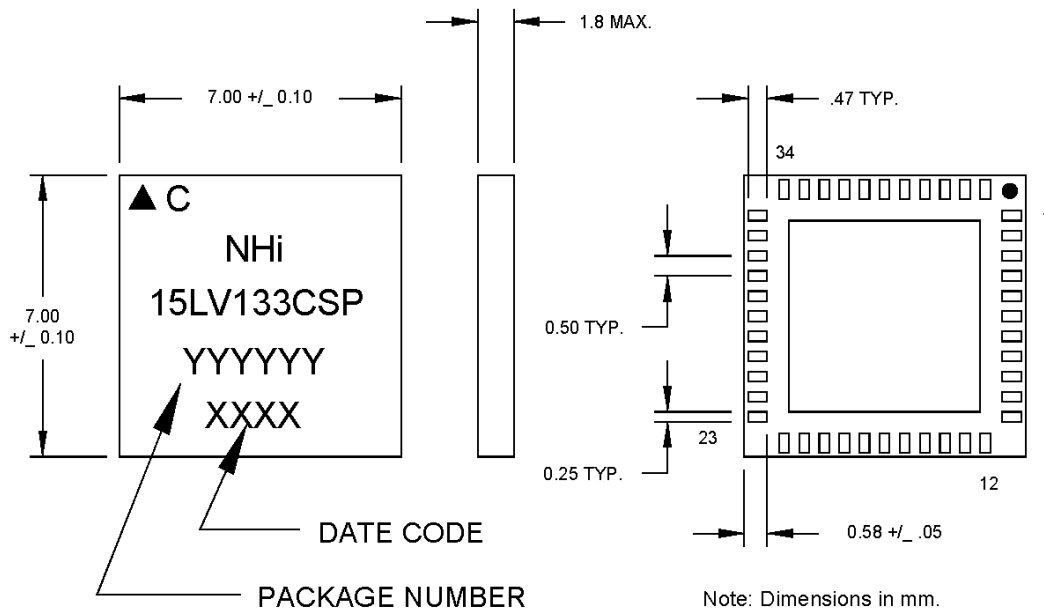

NHi-1567/68/133/134 NHi-15LV67/68/133/134

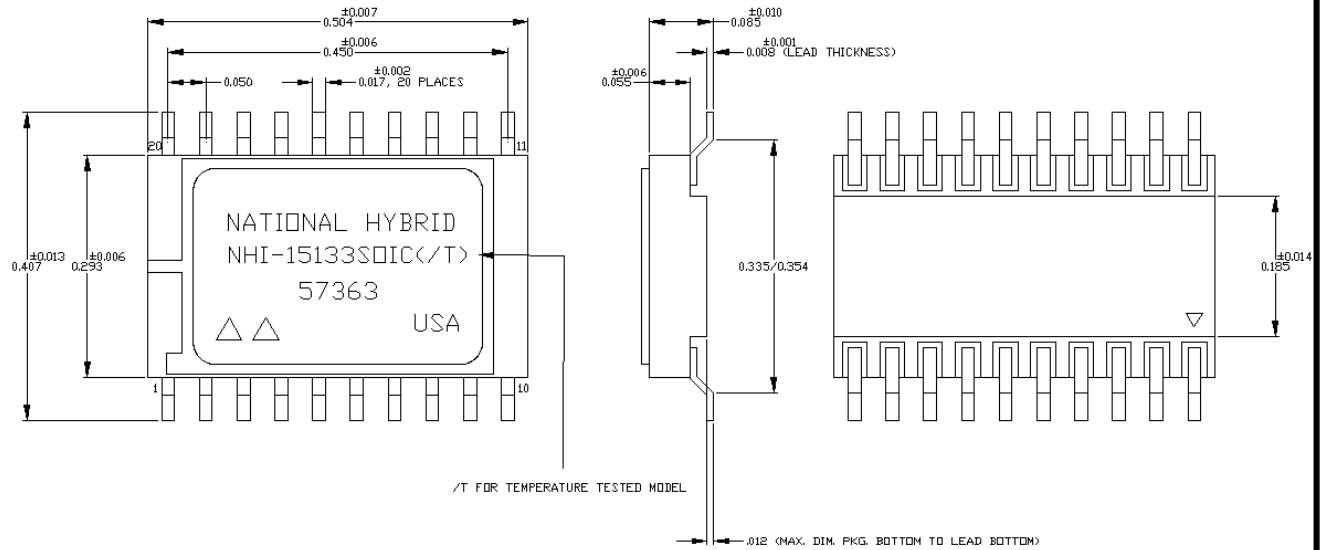

Hermetic Ceramic SOIC

NHi-1567/68 NHi-15LV67/68

Ordering Information

NHi-15LV67CSP/T

GRADE

Blank	Industrial: -40 to +85 °C
/T	Military: -55 to +125 °C
/M	Mil-Prf-38534 Table VIII Screening
/X	Mil-Prf-38534 Compliant

PACKAGE

Blank	20 Pin Plug-In
FP	20 Pin Flat Pack
GW	20 Pin Gull Wing
SOIC	20 Pin Small Outline Integrated Circuit
CSP	44 Pin Chip Scale Package

DEVICE LOGIC

67	Rxo_H, Rxo_L Standby Logic '0'
68	Rxo_H, Rxo_L Standby Logic '1'

DEVICE TYPE

Blank	+5V
LV	+3.3V
M	Mac-Air, +5V
MLV	Mac-Air, +3.3V

NHi-15133/134 NHi-15LV133/134

Ordering Information

NHi-15LV133CSP/T

