



NJBK7 Motor protection delay

1. General

NJBK7 series motor protection relay (hereinafter referred to as protector) is used to provide overload, locked rotor, phase failure, three-phase current unbalance, ground and PTC temperature protection for AC motors with a frequency of AC 50Hz, a rated insulation voltage of up to 690V and a rated operational current of 80A-800A that operate continuously or intermittently. The protector uses flexible Rogowski coil to acquire current and features wide setting current range, high accuracy and convenient installation. The protector has RS485 interface and 4mA-20mA analog transmission interface, permits network communication and can realize remote monitor and control and fault inquiry of motors by means of upper computer. The protector is generally used in combination with AC contactor.

Standards: GB 14084.4, IEC 60947-4-1.

2. Type designation

N JBK 7 - 800 / □

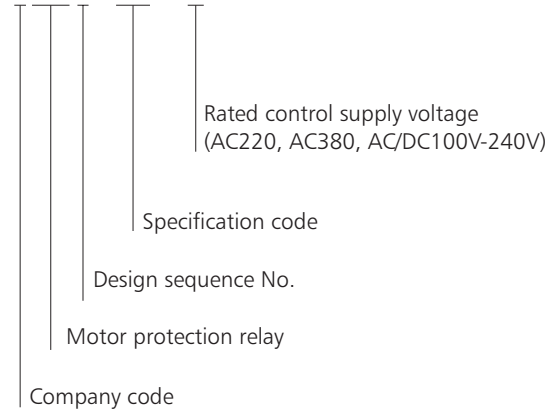

3. Technical data

- 3.1 Altitude: should not exceed 2000m;
- 3.2 Ambient temperature: $-5^{\circ}\text{C} \sim +40^{\circ}\text{C}$, and the average temperature in 24h should not exceed $+35^{\circ}\text{C}$;
- 3.3 Atmospheric conditions: The relative air humidity should not exceed 50% at the maximum temperature of $+40^{\circ}\text{C}$. The relative humidity may be higher at lower temperatures, for example, the air humidity can be up to 90% at $+20^{\circ}\text{C}$. Special measures should be taken if condensation occurs on the product occasionally due to temperature variation;
- 3.4 Pollution degree: 3;
- 3.5 The inclination between the mounting plane and the vertical plane should not exceed $\pm 5^{\circ}$;
- 3.6 In non-explosive media that do not contain a sufficient amount of gas or conductive dust to cause metal corrosion or insulation failure;
- 3.7 In places with rain and snow protection equipment and not full of vapor;
- 3.8 In places where there is no significant shake, impact or vibration;
- 3.9 Mounting category: III;
- 3.10 Degree of protection of enclosure: Ip20.

4. Main data and technical characteristics

4.1 Main circuit: rated insulation voltage: AC690V, rated frequency: 50Hz

Model	Setting current (A)	Setting current range (A)	Matching motor power (kW)
NJBK7-800/□	800	80~800	40~400

4.2 Auxiliary circuit: rated insulation voltage: AC380V, rated frequency: 50Hz, data of auxiliary contact

Usage category	AC-15	
Rated operational voltage Ue(V)	240	380
Rated operational current Ie(A)	1.5	0.95
Conventional heating current Ith(A)	5	

4.3 Structural features

- 4.3.1 Split mounting;
- 4.3.2 LCD display, key setting;
- 4.3.3 Has start delay function;
- 4.3.4 Has fault memory function, permits inquiry of fault record;
- 4.3.5 Has RS485 interface, supports MODBUS protocol, permits network communication;
- 4.3.6 Has 4mA-20mA analog output interface;
- 4.3.7 Has two groups of output contacts, 1Z protection contact and 1H auxiliary contact, and permits autotransformer reduced voltage starting and star-delta starting;
- 4.3.8 Power consumption: ≤3VA.

5. Protection characteristics

5.1 Operating characteristics of overload protection

Overload curve	Overload multiple								Note
	1.1	1.2	1.5	2	5	6	7.2		
Kr=1	75	63	40	22	3.6	2.5	1.8		
Kr=2	150	125	80	45	7.2	5	3.5	In conformity with Class 10A	
Kr=3	298	250	160	90	14	10	6.9	In conformity with Class 10	
Kr=4	595	500	320	180	29	20	14	In conformity with Class 20	
Kr=5	892	750	480	270	43	30	21	In conformity with Class 30	

5.2 Operating characteristics of phase failure protection

When the current of any phase of the three-phase current of the main circuit is equal to zero, the protector operates for a period of ≤5s.

5.3 Operating characteristics of three-phase current unbalance protection

When the three-phase current of the main circuit meets the following formula, the protector operates for a period of ≤5s.

$$\frac{I_{\max} - I_{\min}}{I_{\max}} \times 100\% \geq \text{set current unbalance rate}$$

I_{max}: Max. phase current value

I_{min}: Min. phase current value

5.4 Operating characteristics of ground protection

When zero sequence current ≥ set ground protection current value, the protector operates for a period of ≤1s.

5.5 Operating characteristics of locked rotor protection

When Max. phase current ≥ setting current value × set locked rotor multiple, the protector operates for a period of ≤1s.

5.6 Operating characteristics of temperature protection

The over-temperature protection function of the protector is accomplished by detecting the resistance of the PTC thermistor preembedded in the motor stator winding. When the resistance of the PTC thermistor ≥2.5kΩ, the protector operates for a period of ≤1s.

5.7 Communication: The protector provides RS485 interface and supports MODBUS protocol.

Tripping characteristic curve

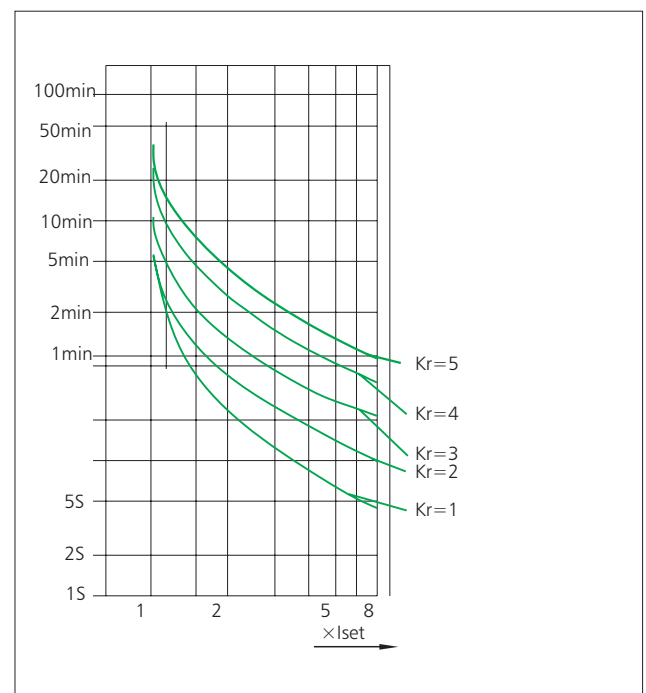

6. Connection diagram

Figure 1 Direct starting connection diagram in case the control supply voltage is 220V and the rated operational voltage is 220V

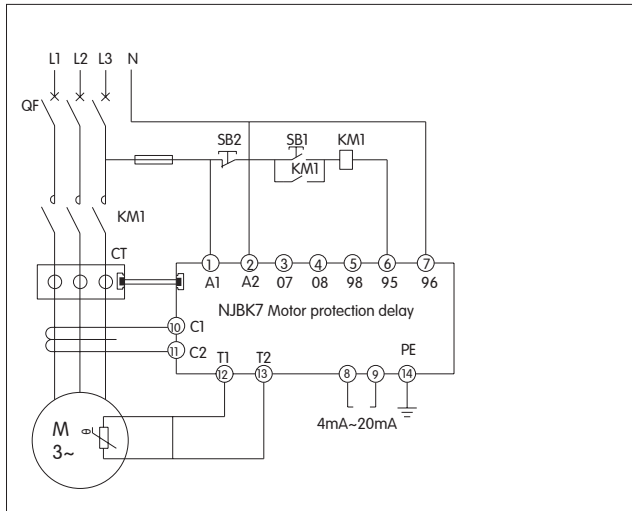

Figure 2 Secondary current direct starting connection diagram in case the control supply voltage is 220V and the rated operational voltage is 220V

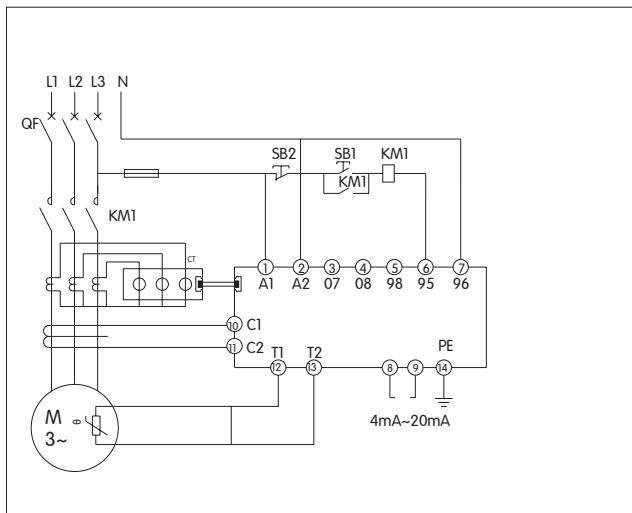

Figure 3 Autotransformer reduced voltage starting connection diagram in case the control supply voltage is 220V and the rated operational voltage is 220V

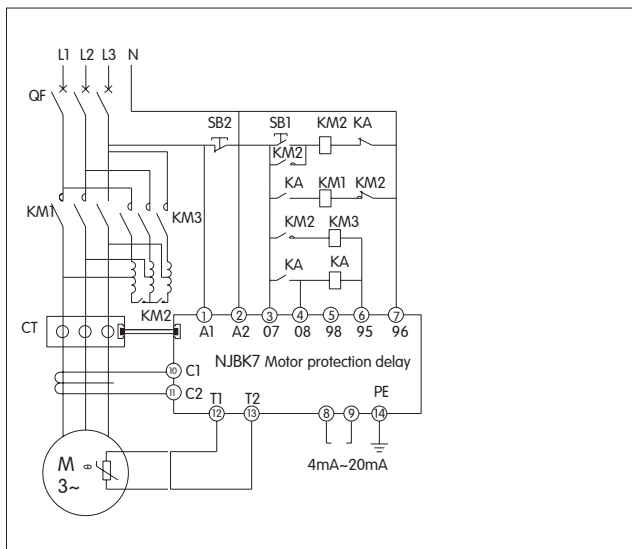
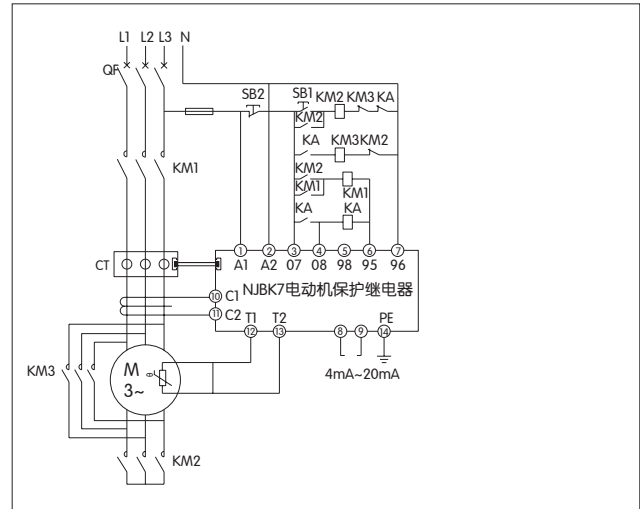

Figure 4 Star-delta starting connection diagram in case the control supply voltage is 220V and the rated operational voltage is 220V



7. Overall and mounting dimensions (mm)

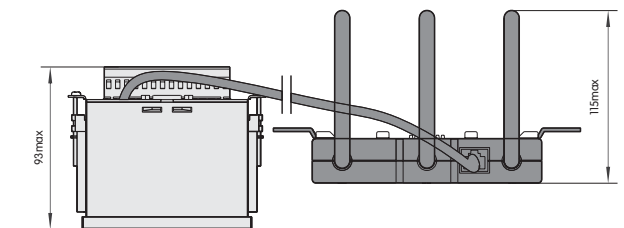
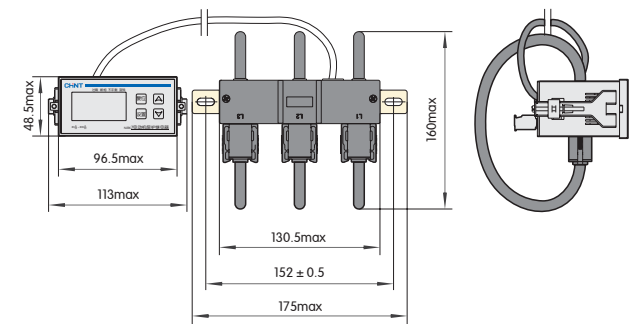

Figure 6 Transformer mounting type 1

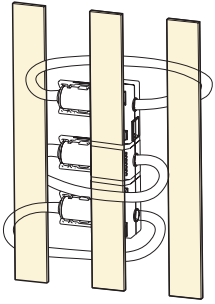

Figure 7 Transformer mounting type 2

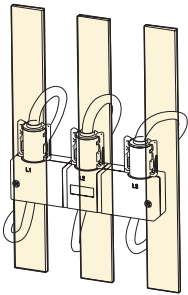

Figure 8 Opening size of the main machine

