

W-CDMA Dual LNA GaAs MMIC

GENERAL DESCRIPTION

The NJG1119PB4 is a Dual band LNA IC designed for W-CDMA cellular phone of 2.1GHz and 800MHz band.

This IC has a LNA pass-through function to select high gain mode or low gain mode.

An ultra small and ultra thin package of FFP12-B4 is adopted.

PACKAGE OUTLINE

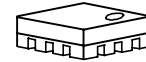

NJG1119PB4

FEATURES

- Low voltage operation +2.7V
- Low current consumption
 - 2.4mA typ. @2.1GHz band (High Gain Mode)
 - 2.0mA typ. @800MHz band (High Gain Mode)
 - 4uA typ. @800MHz / 2.1GHz band (Low Gain Mode)
- Small package FFP12-B4 (Package size: 2.0 x 2.0 x 0.65mm typ)

[High gain mode]

- High gain
 - 14.5dB typ. @ $f_{RF}=2140\text{MHz}$ 16.0dB typ. @ $f_{RF}=885\text{MHz}$
- Low noise figure
 - 1.7dB typ. @ $f_{RF}=2140\text{MHz}$
 - 1.45dB typ. @ $f_{RF}=885\text{MHz}$
- High Input IP3
 - 3.5dBm typ. @ $f_{RF}=2140.0+2140.1\text{MHz}$, Pin=-36dBm
 - 3.5dBm typ. @ $f_{RF}=885.0+885.1\text{MHz}$, Pin=-36dBm

[Low gain mode]

- Gain
 - 4.0dB typ. @ $f_{RF}=2140\text{MHz}$
 - 4.5dB typ. @ $f_{RF}=885\text{MHz}$
- Low noise figure
 - 4.0dB typ. @ $f_{RF}=2140\text{MHz}$
 - 4.5dB typ. @ $f_{RF}=885\text{MHz}$
- High Input IP3
 - +2.5dBm typ. @ $f_{RF}=2140.0+2140.1\text{MHz}$, Pin=-20dBm
 - +2.0dBm typ. @ $f_{RF}=885.0+885.1\text{MHz}$, Pin=-20dBm

PIN CONFIGURATION

(Top View)

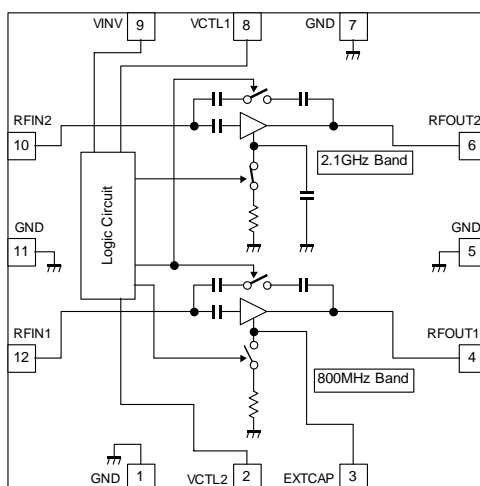

Pin Connection

1. GND
2. VCTL2
3. EXTCAP
4. RFOUT1 (800MHz band)
5. GND
6. RFOUT2 (2.1GHz band)
7. GND
8. VCTL1
9. VINV
10. RFIN2 (2.1GHz band)
11. GND
12. RFIN1 (800MHz band)

Note: Specifications and description listed in this catalog are subject to change without prior notice.

NJG1119PB4

www.DataSheet4U.com

■ABSOLUTE MAXIMUM RATINGS

($T_a=+25^{\circ}\text{C}$, $Z_s=Z_l=50\Omega$)

PARAMETERS	SYMBOL	CONDITIONS	RATINGS	UNITS
Operating voltage	V_{DD}		5.0	V
Inverter supply voltage	V_{INV}		5.0	V
Control voltage	V_{CTL}		5.0	V
Input power	P_{in}	$V_{DD}=2.7V$	+15	dBm
Power dissipation	P_D		300	mW
Operating temperature	T_{opr}		-40~+85	$^{\circ}\text{C}$
Storage temperature	T_{stg}		-55~+125	$^{\circ}\text{C}$

■ELECTRICAL CHARACTERISTICS 1 (DC)

($V_{DD}=V_{INV}=2.7V$, $T_a=+25^{\circ}\text{C}$, $Z_s=Z_l=50\Omega$)

PARAMETERS	SYMBOL	CONDITIONS	MIN	TYP	MAX	UNITS
Operating voltage	V_{DD}		2.5	2.7	4.5	V
Inverter supply voltage	V_{INV}		2.5	2.7	4.5	V
Control voltage1 (High)	$V_{CTL1(H)}$		2.0	2.7	$V_{INV}+0.3$	V
Control voltage1 (Low)	$V_{CTL1(L)}$		0	0	0.8	V
Control voltage 2 (High)	$V_{CTL2(H)}$		2.0	2.7	$V_{INV}+0.3$	V
Control voltage 2 (Low)	$V_{CTL2(L)}$		0	0	0.8	V
Operating current1 800MHz[High gain mode]	I_{DD1}	$V_{CTL1}=2.7V$, $V_{CTL2}=2.7V$	-	2.4	2.9	mA
Operating current2 2.1GHz[High gain mode]	I_{DD2}	$V_{CTL1}=0V$, $V_{CTL2}=2.7V$	-	2.0	2.4	mA
Operating current 3 800M/2.1GHz[Low gain mode]	I_{DD3}	$V_{CTL1}=0$ or $2.7V$, $V_{CTL2}=0V$	-	4	13	μA
Inverter current1	I_{INV1}	RF OFF, $V_{CTL}=2.7V$	-	160	250	μA
Inverter current2	I_{INV2}	RF OFF, $V_{CTL}=0V$	-	210	330	μA
Control current 1	I_{CTL1}	$V_{CTL1}=2.7V$	-	20	50	μA
Control current 2	I_{CTL2}	$V_{CTL2}=2.7V$	-	20	50	μA

■ ELECTRICAL CHARACTERISTICS 2 (2.1GHz band High Gain mode)

($V_{DD}=V_{INV}=2.7V$, $V_{CTL1}=0V$, $V_{CTL2}=2.7V$, $f_{RF}=2140MHz$, $T_a=+25^{\circ}C$, $Z_s=Z_f=50\Omega$, TEST CIRCUIT)

PARAMETERS	SYMBOL	CONDITIONS	MIN	TYP	MAX	UNITS
Small signal gain1	Gain1		13.0	14.5	16.0	dB
Noise figure1	NF1		-	1.7	2.0	dB
Pin at 1dB gain compression point1	$P_{-1dB(1)}$		-16.0	-14.0	-	dBm
Input 3rd order intercept point	IIP3_1	$f1=f_{RF}$, $f2=f_{RF}+100kHz$, $P_{in}=-36dBm$	-6.0	-3.5	-	dBm
RF Input VSWR1	$VSWR_i1$		-	1.7	2.2	
RF Output VSWR1	$VSWR_o1$		-	1.9	2.5	

■ ELECTRICAL CHARACTERISTICS 3 (2.1GHz band Low Gain mode)

($V_{DD}=V_{INV}=2.7V$, $V_{CTL1}=V_{CTL2}=0V$, $f_{RF}=2140MHz$, $T_a=+25^{\circ}C$, $Z_s=Z_f=50\Omega$, TEST CIRCUIT)

PARAMETERS	SYMBOL	CONDITIONS	MIN	TYP	MAX	UNITS
Small signal gain2	Gain2		-6.0	-4.0	-2.5	dB
Noise figure2	NF2		-	4.0	6.0	dB
Pin at 1dB gain compression point2	$P_{-1dB(2)}$		+5.0	+11.0	-	dBm
Input 3rd order intercept point2	IIP3_2	$F1=f_{RF}$, $f2=f_{RF}+100kHz$, $P_{in}=-36dBm$	0	+2.5	-	dBm
RF Input VSWR2	$VSWR_i2$		-	2.0	2.5	
RF Output VSWR2	$VSWR_o2$		-	1.6	2.0	

NJG1119PB4

www.DataSheet4U.com

■ELECTRICAL CHARACTERISTICS 4 (800MHz band High Gain mode)

($V_{DD}=V_{INV}=2.7V$, $V_{CTL1}=V_{CTL2}=2.7V$, $f_{RF}=885MHz$, $T_a=+25^{\circ}C$, $Z_s=Z_f=50\Omega$, TEST CIRCUIT)

PARAMETERS	SYMBOL	CONDITIONS	MIN	TYP	MAX	UNITS
Small signal gain1	Gain3		14.5	16.0	17.5	dB
Noise figure1	NF3		-	1.45	1.75	dB
Pin at 1dB gain compression point1	$P_{-1dB(3)}$		-17.0	-15.0	-	dBm
Input 3rd order intercept point	IIP3_3	$f1=f_{RF}$, $f2=f_{RF}+100kHz$, $P_{in}=-36dBm$	-6.0	-3.5	-	dBm
RF Input VSWR1	$VSWR_i3$		-	1.6	2.1	
RF Output VSWR1	$VSWR_o3$		-	1.7	2.3	

■ELECTRICAL CHARACTERISTICS 5 (800MHz band Low Gain mode)

($V_{DD}=V_{INV}=2.7V$, $V_{CTL1}=2.7V$, $V_{CTL2}=0V$, $f_{RF}=885MHz$, $T_a=+25^{\circ}C$, $Z_s=Z_f=50\Omega$, TEST CIRCUIT)

PARAMETERS	SYMBOL	CONDITIONS	MIN	TYP	MAX	UNITS
Small signal gain2	Gain4		-6.0	-4.0	-3.0	dB
Noise figure2	NF4		-	4.5	6.5	dB
Pin at 1dB gain compression point2	$P_{-1dB(4)}$		+4.0	+9.0	-	dBm
Input 3rd order intercept point2	IIP3_4	$F1=f_{RF}$, $f2=f_{RF}+100kHz$, $P_{in}=-36dBm$	1.5	+2.0	-	dBm
RF Input VSWR2	$VSWR_i4$		-	1.7	2.3	
RF Output VSWR2	$VSWR_o4$		-	1.6	2.1	

■ TERMINAL INFORMATION

No.	SYMBOL	DESCRIPTION
1	GND	Ground terminal. (0V)
2	VCTL2	Control voltage supply terminal. The high level voltage of this terminal selects High Gain Mode. The low level voltage of this terminal selects Low Gain Mode.
3	EXTCAP	An external bypass capacitor is required. (Please refer to TEST CIRCUIT.)
4	RFOUT1	Output terminal of 800MHz band. This terminal is also the power supply terminal of the LNA, please use inductor (L3) to connect power supply.
5	GND	Ground terminal. (0V)
6	RFOUT2	Output terminal of 2.1GHz band. This terminal is also the power supply terminal of the LNA, please use inductor (L7) to connect power supply.
7	GND	Ground terminal. (0V)
8	VCTL1	Control voltage supply terminal. The high level voltage of this terminal selects 800MHz.band. The low level voltage of this terminal selects 2.1GHz band.
9	VINV	Inverter voltage supplies terminal.
10	RFIN2	RF input terminal of 2.1GHz band. The RF signal is input through external matching circuit connected to this terminal. The DC blocking capacitor is not required.
11	GND	Ground terminal. (0V)
12	RFIN1	RF input terminal of 800MHz band. The RF signal is input through external matching circuit connected to this terminal. The DC blocking capacitor is not required.

CAUTION

- 1) Ground terminal (No.1, 5, 7, 11) should be connected to the ground plane as low inductance as possible.

NJG1119PB4

www.DataSheet4U.com

ELECTRICAL CHARACTERISTICS 1 (2.1GHz band High Gain Mode)

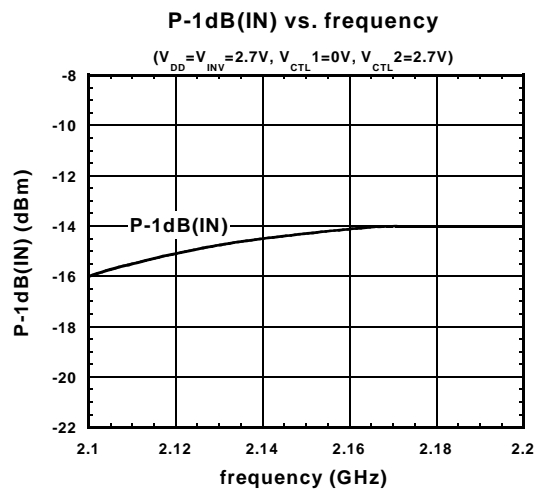
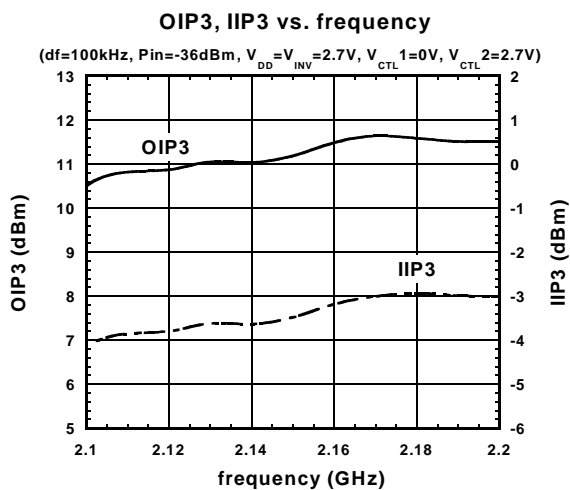
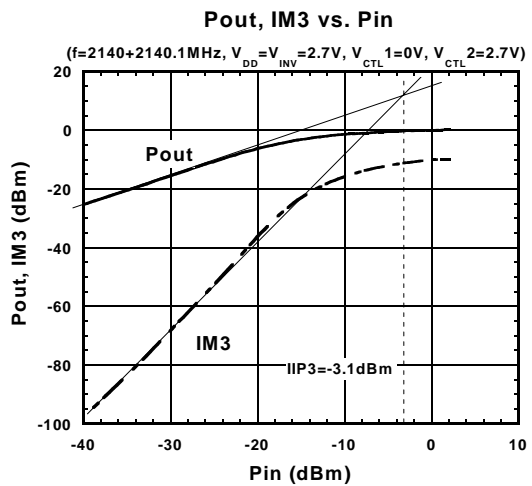
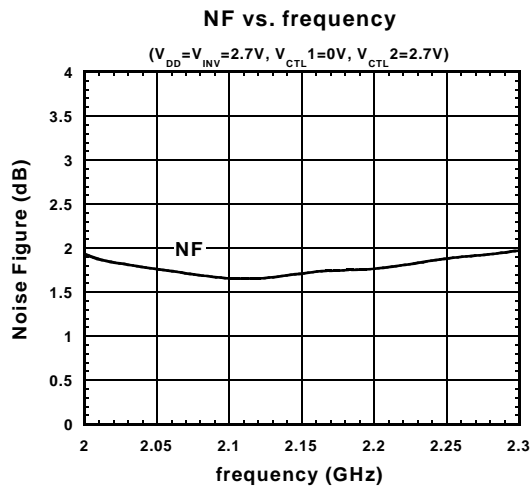
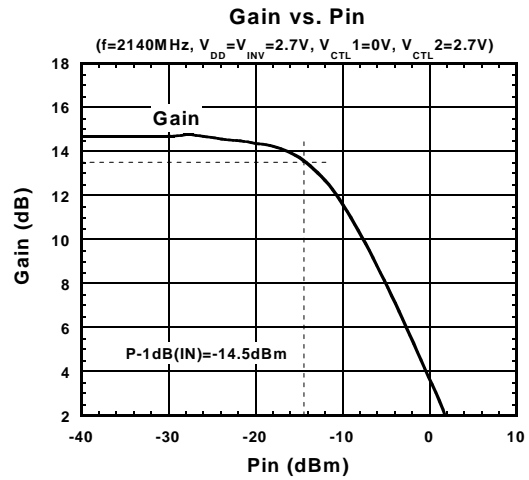
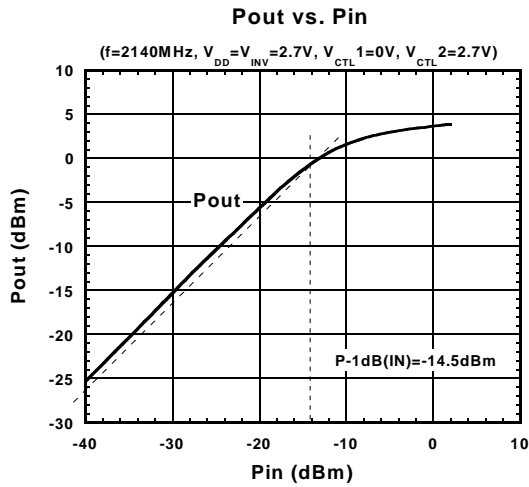

ELECTRICAL CHARACTERISTICS 2 (2.1GHz band High Gain Mode)

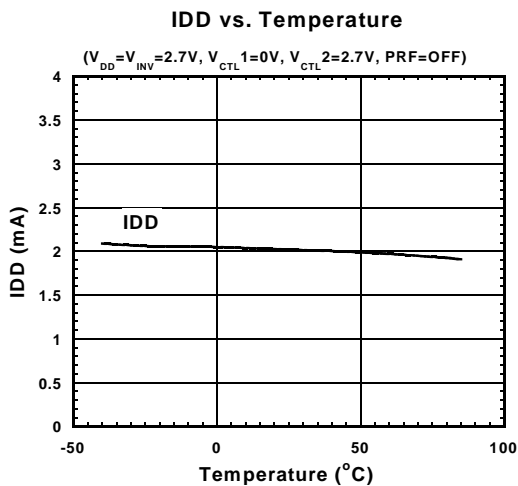
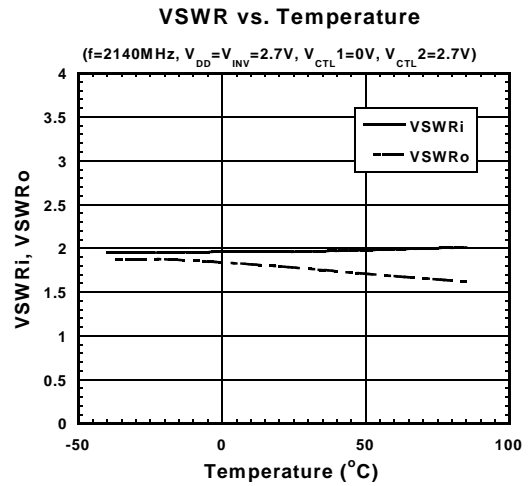
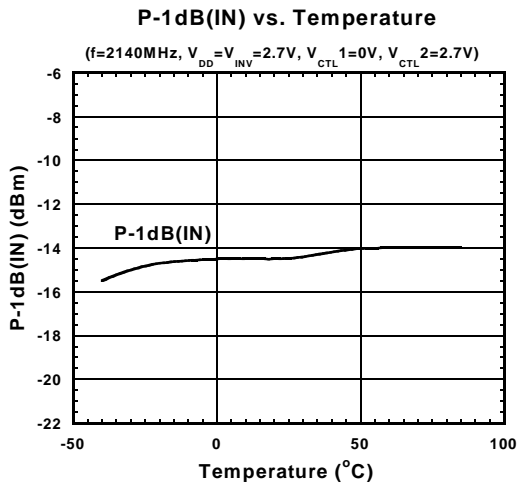
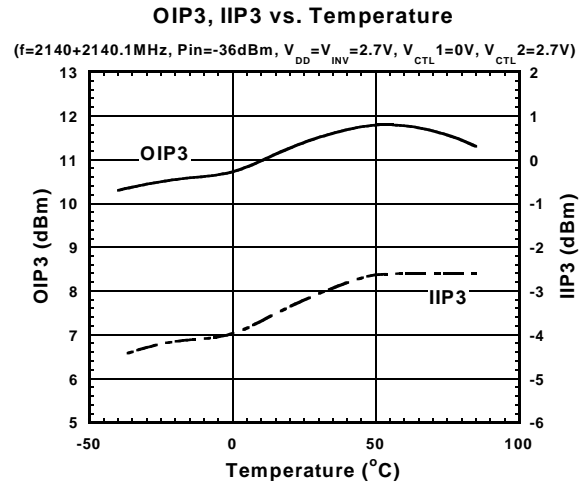
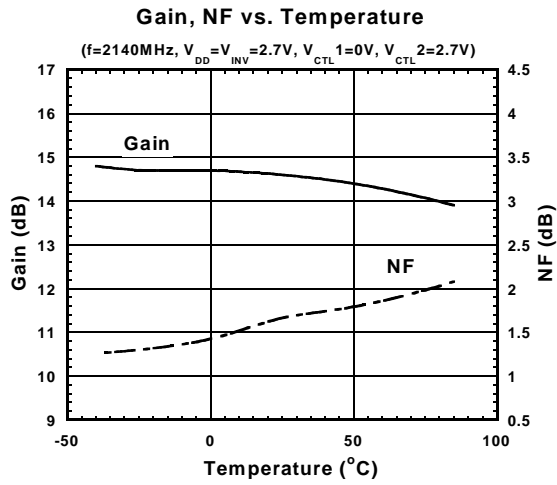

NJG1119PB4

www.DataSheet4U.com

ELECTRICAL CHARACTERISTICS 3(2.1GHz band High Gain Mode)

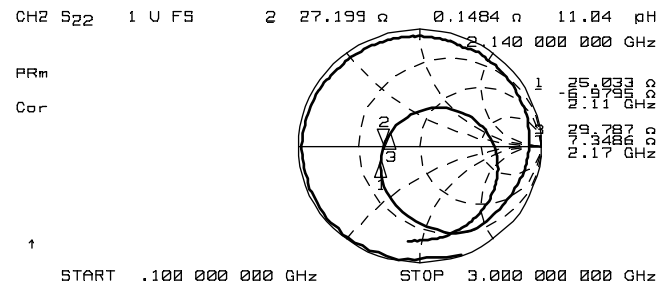
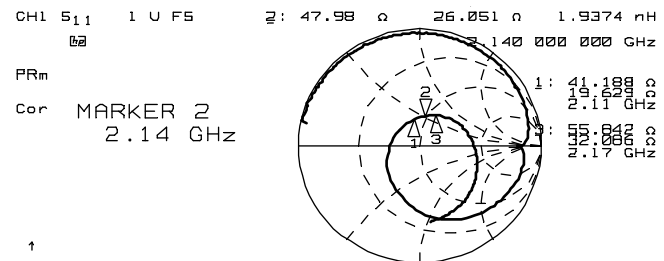
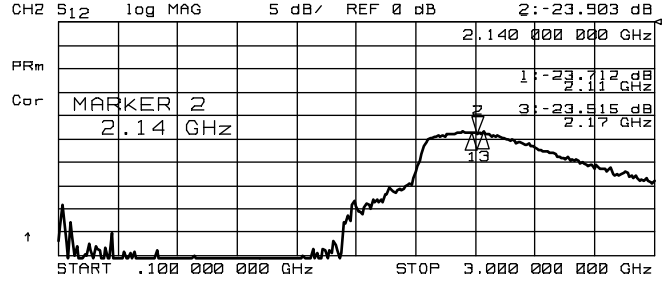
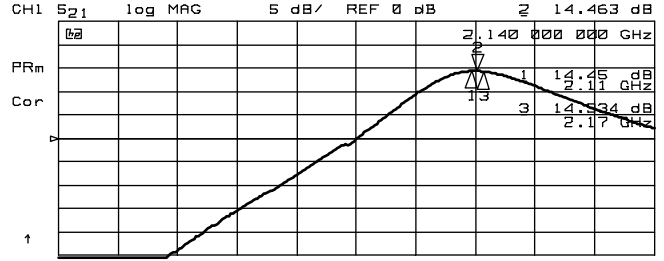
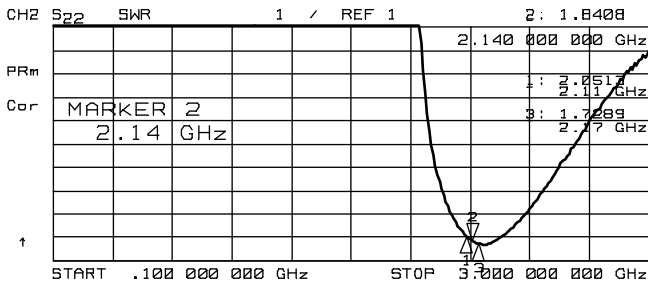
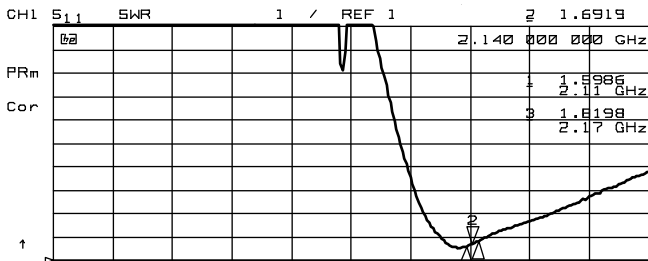
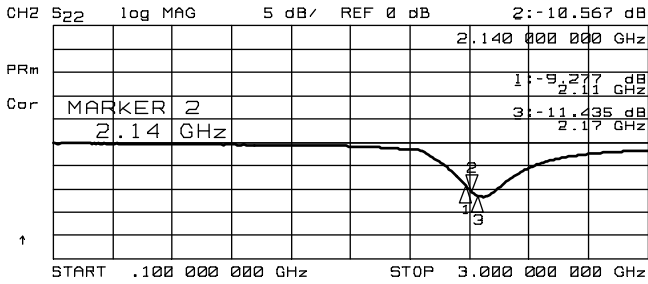

ELECTRICAL CHARACTERISTICS 4(2.1GHz band High Gain Mode)

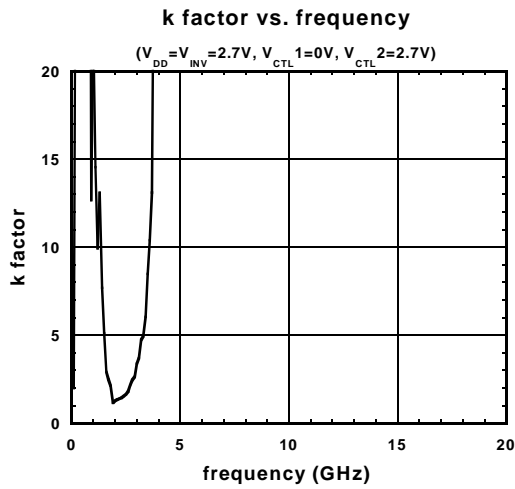
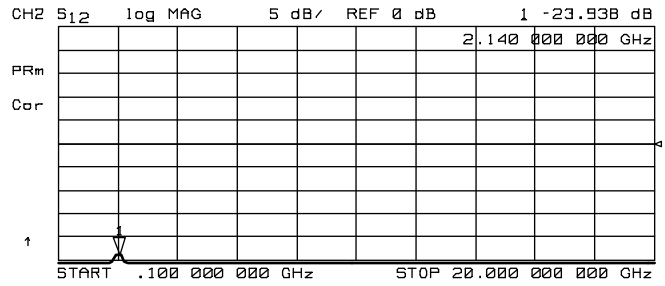
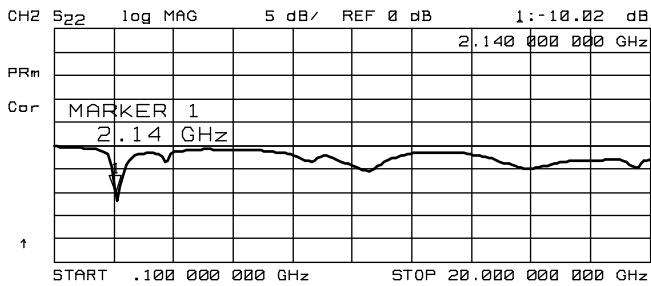
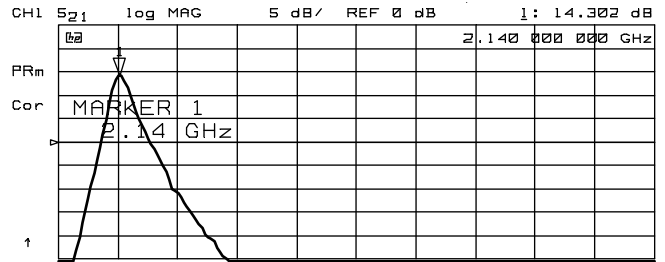
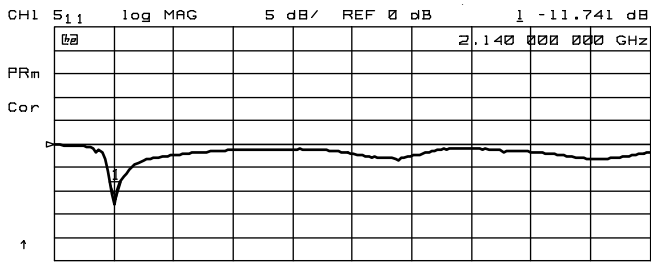

NJG1119PB4

www.DataSheet4U.com

ELECTRICAL CHARACTERISTICS 5(2.1GHz band Low Gain Mode)

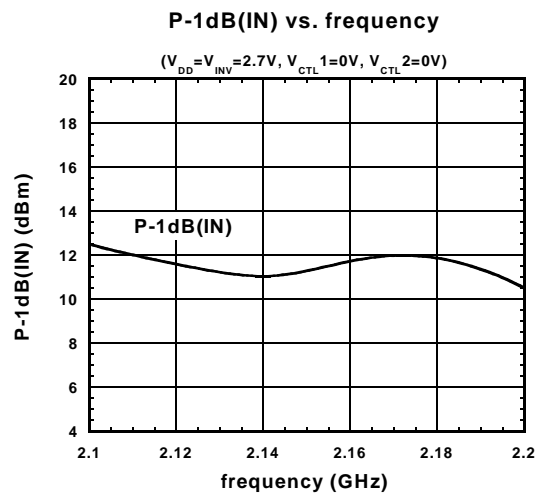
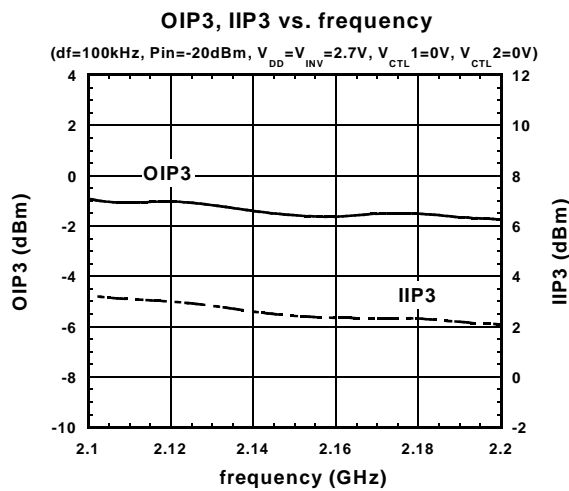
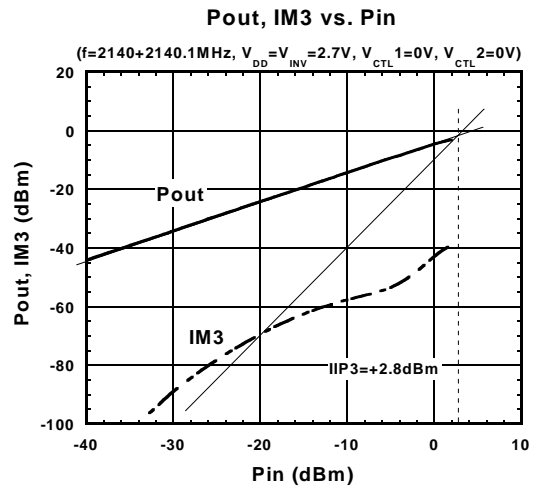
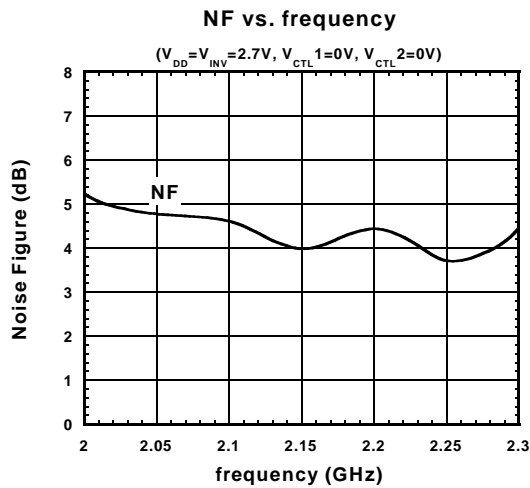
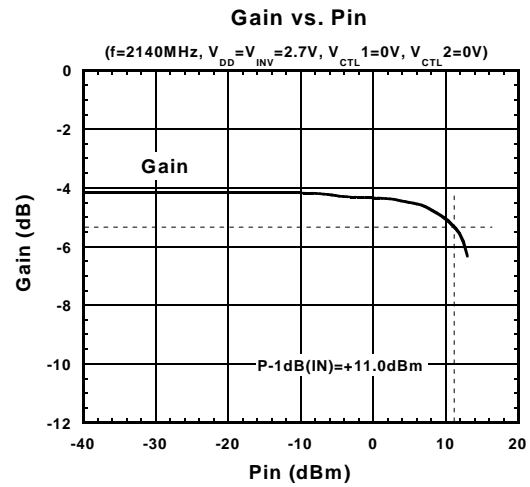
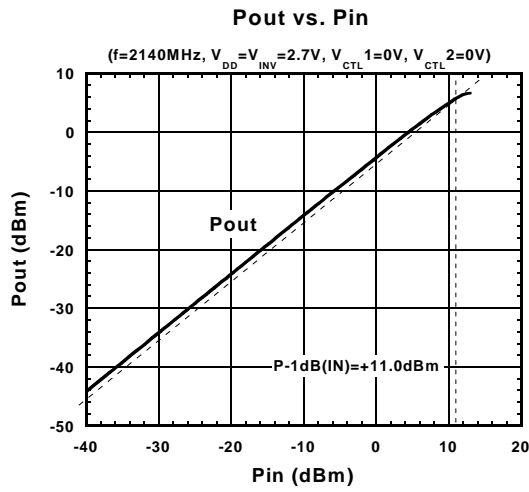

ELECTRICAL CHARACTERISTICS 6(2.1GHz band Low Gain Mode)

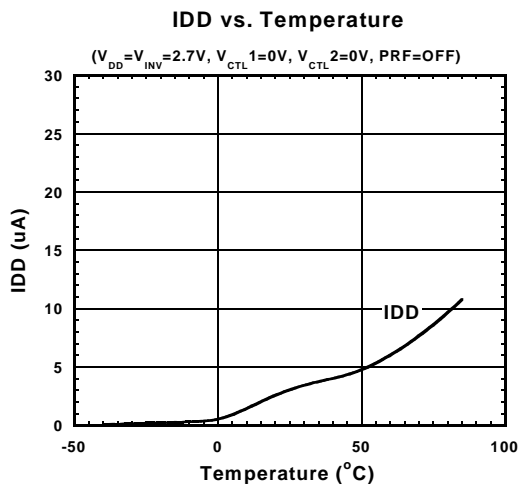
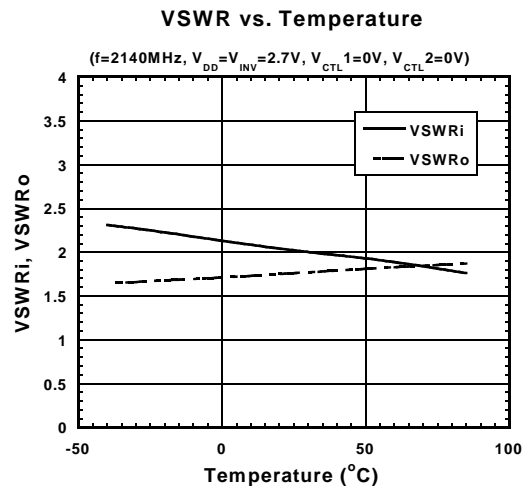
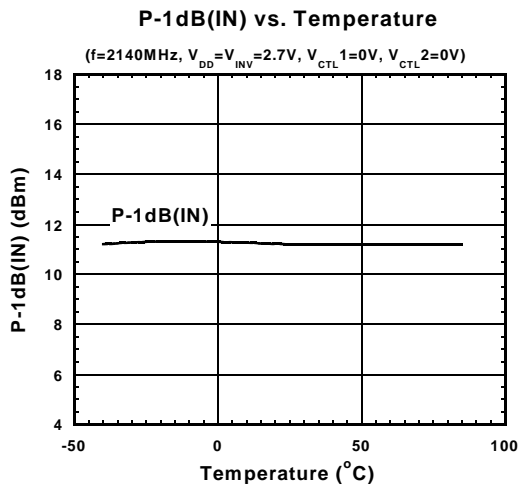
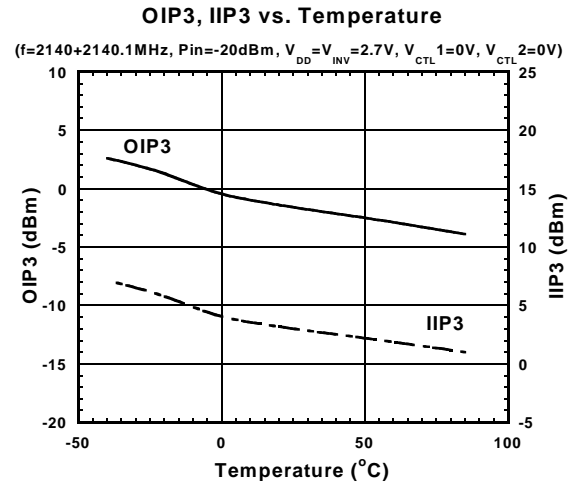
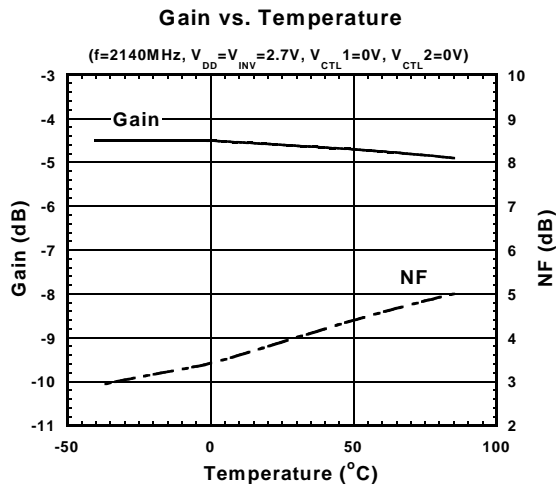

NJG1119PB4

www.DataSheet4U.com

ELECTRICAL CHARACTERISTICS 7(2.1GHz band Low Gain Mode)

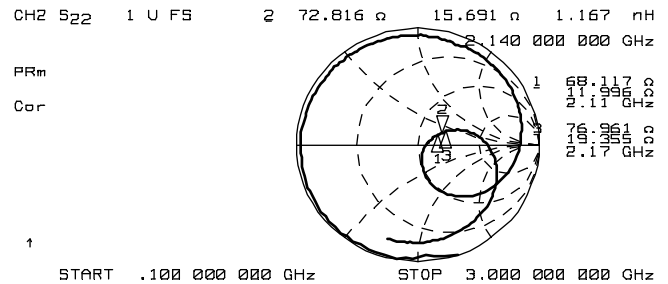
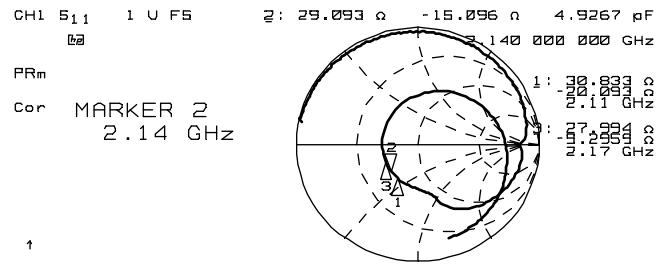
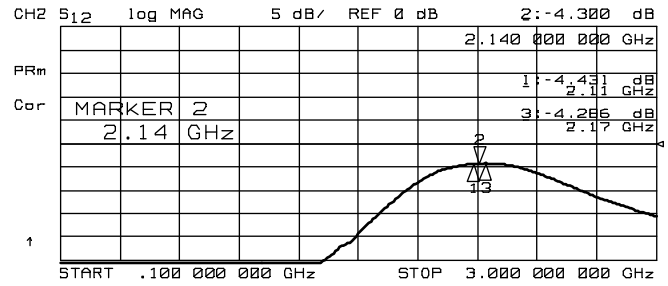
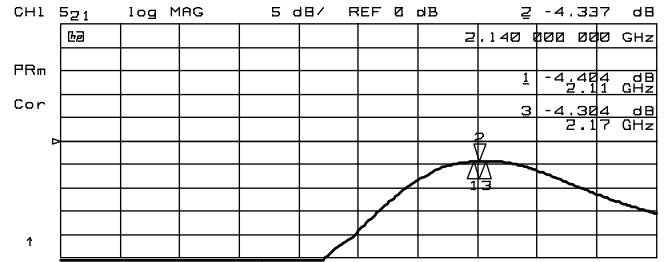
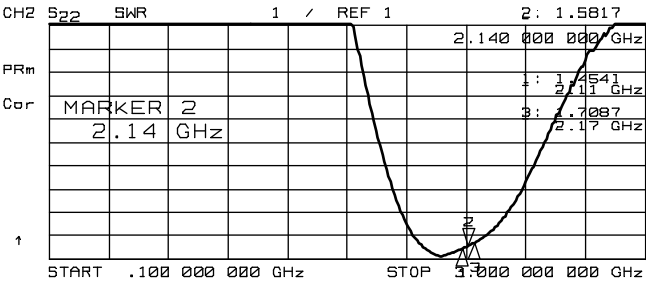
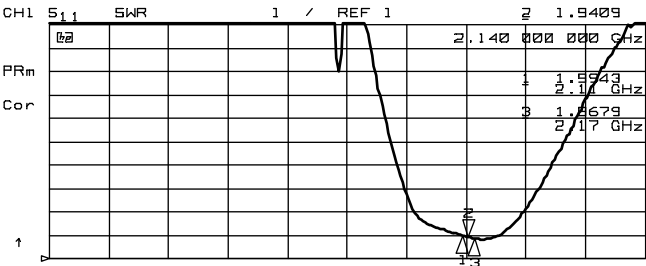
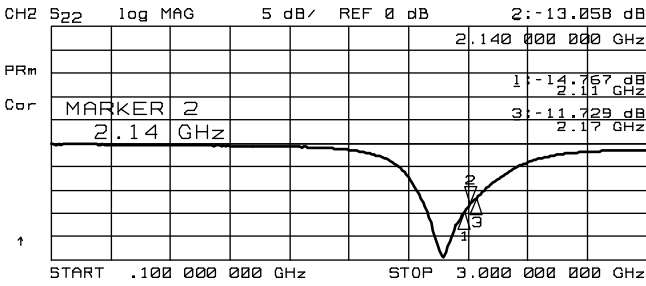

ELECTRICAL CHARACTERISTICS 8(2.1GHz band Low Gain Mode)

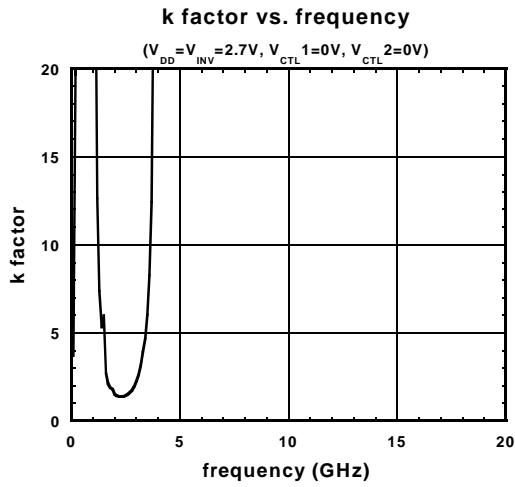
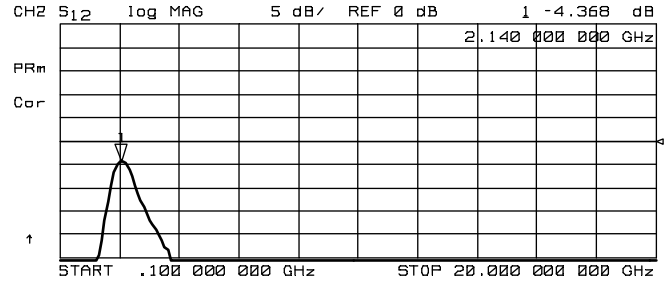
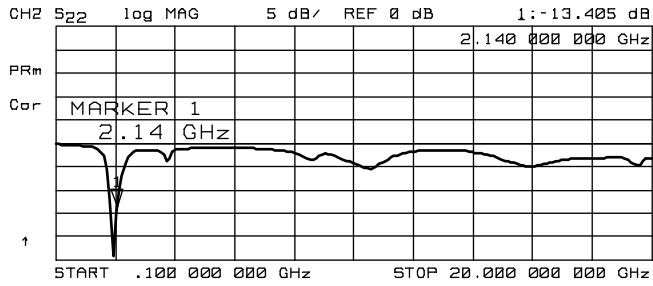
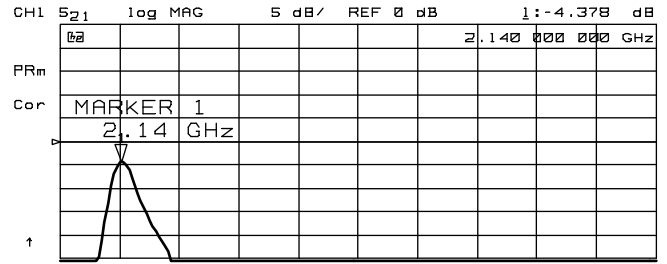
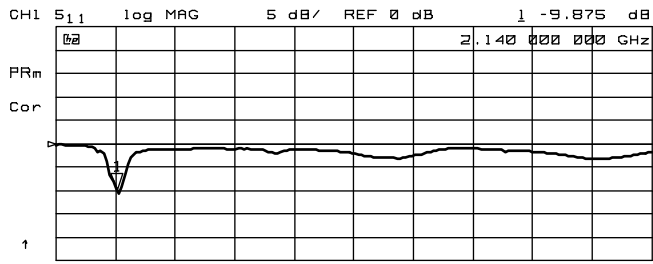

NJG1119PB4

www.DataSheet4U.com

ELECTRICAL CHARACTERISTICS 9(800MHz band High Gain Mode)

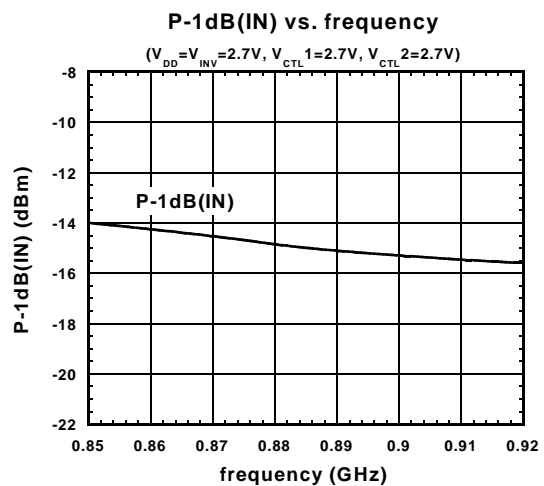
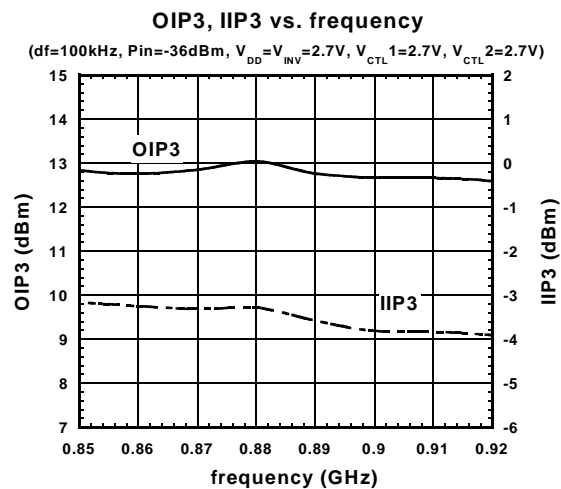
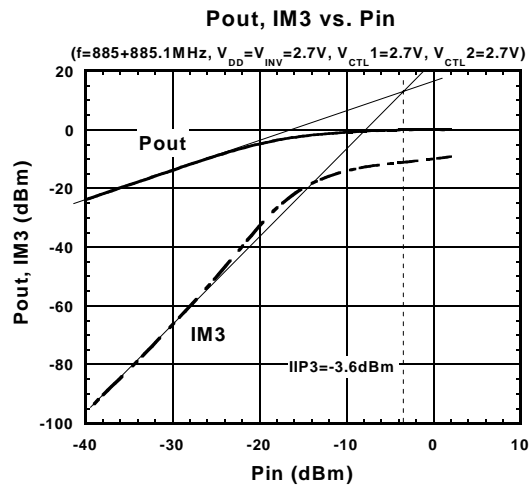
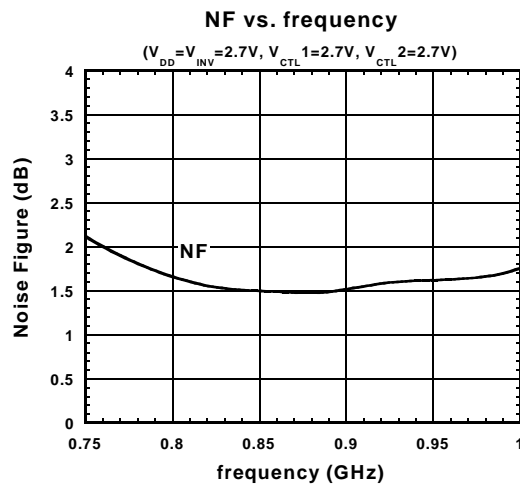
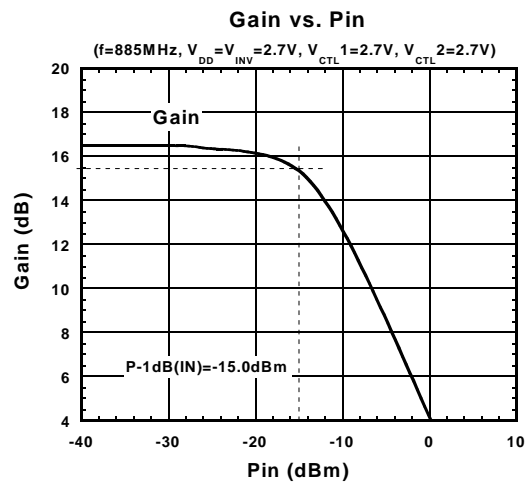
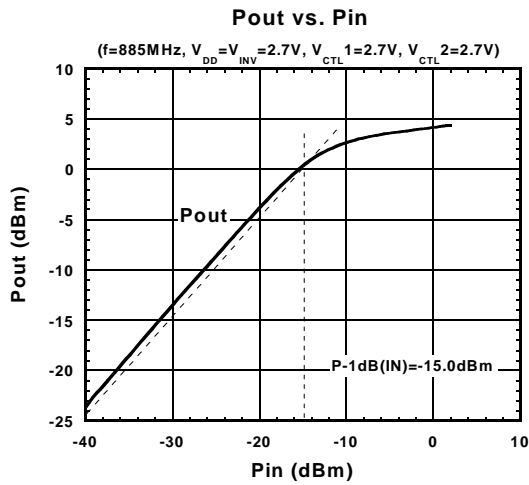

ELECTRICAL CHARACTERISTICS 10(800MHz band High Gain Mode)

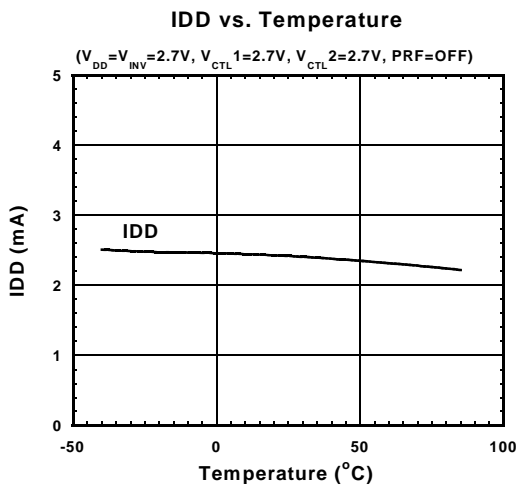
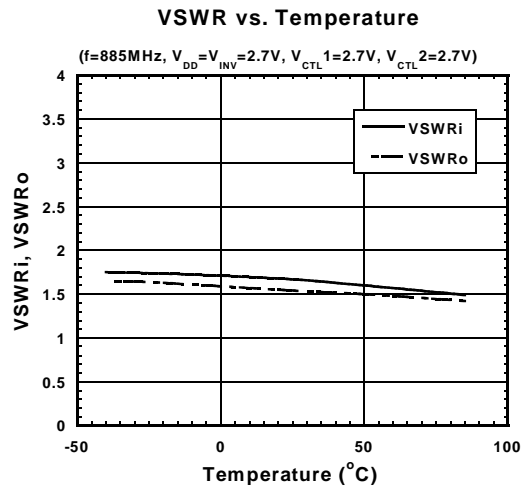
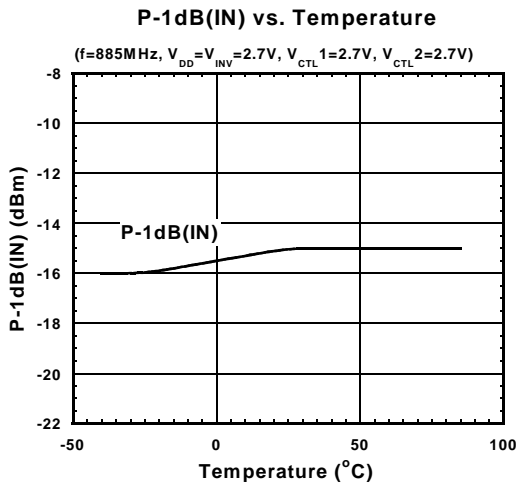
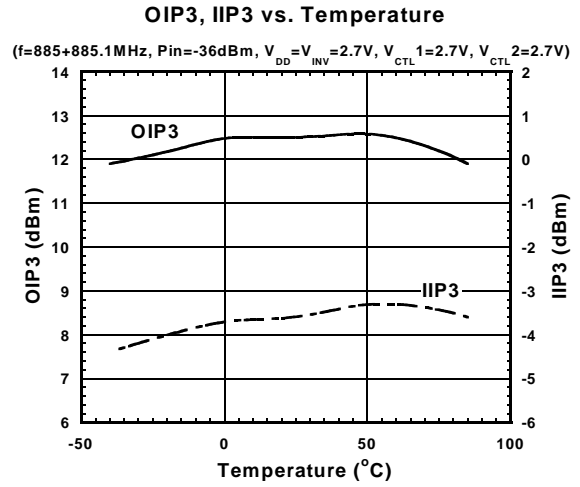
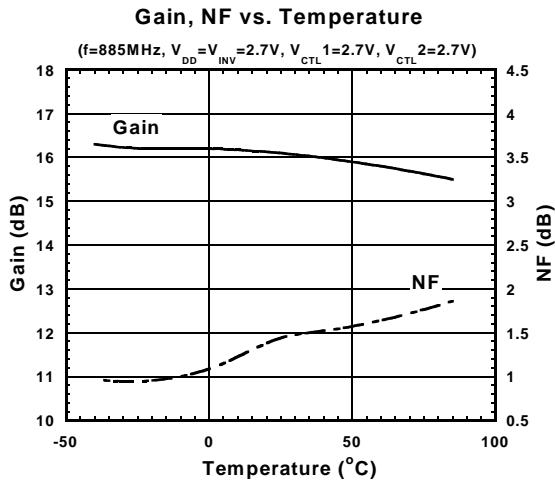

NJG1119PB4

www.DataSheet4U.com

ELECTRICAL CHARACTERISTICS 11(800MHz band High Gain Mode)

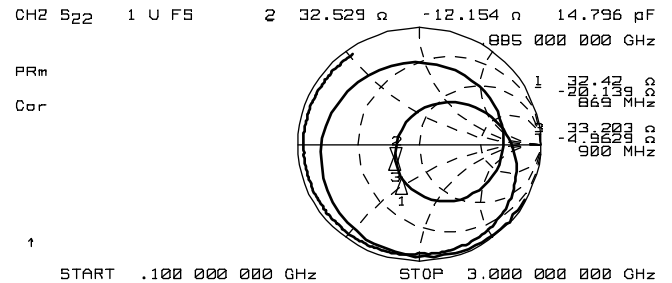
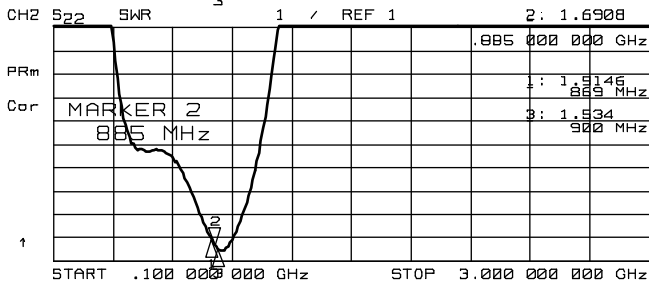
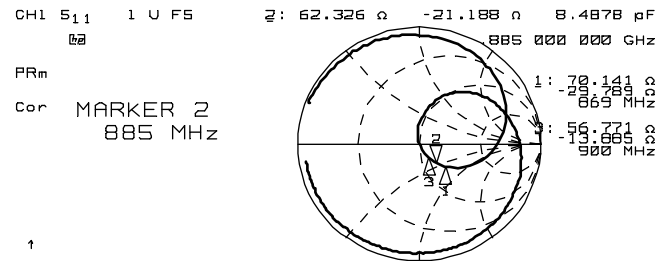
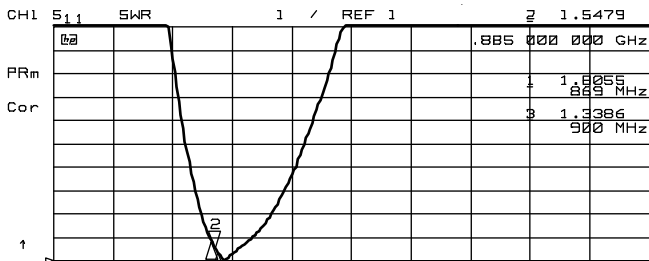
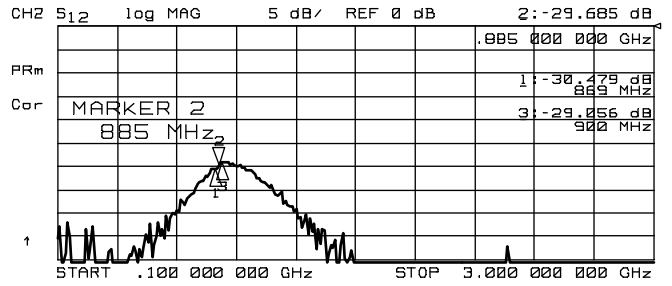
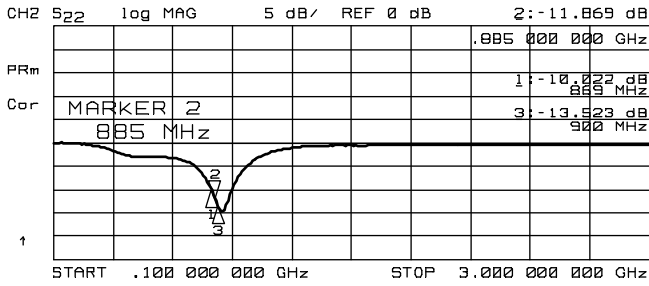
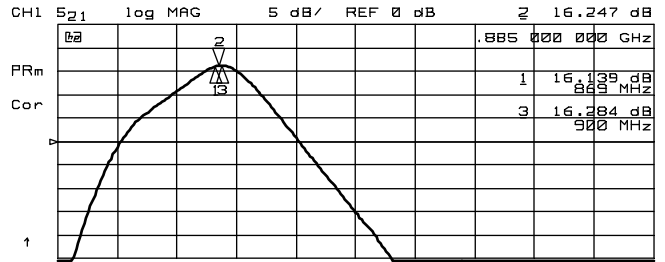
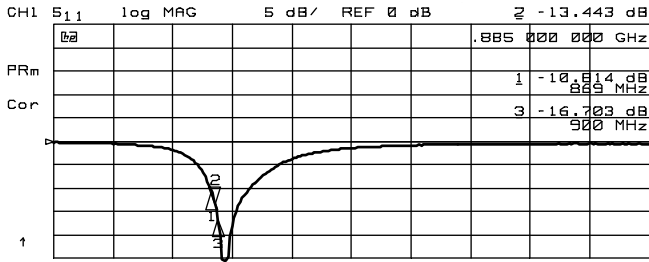

ELECTRICAL CHARACTERISTICS 12(800MHz band High Gain Mode)

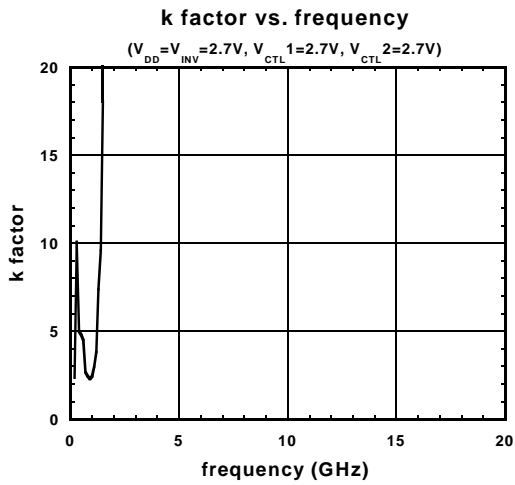
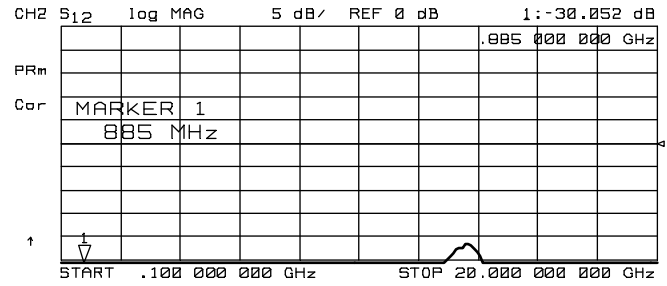
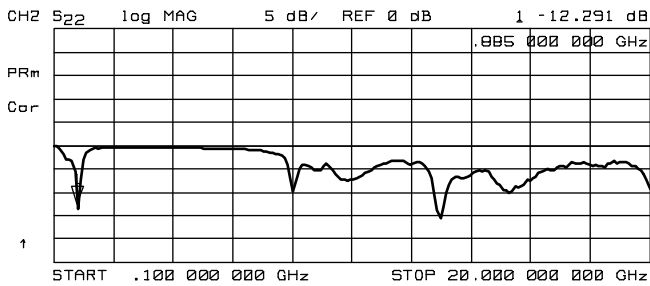
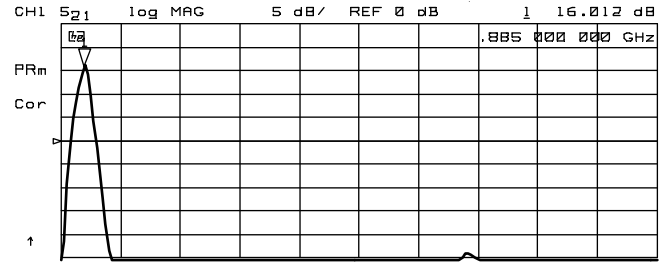
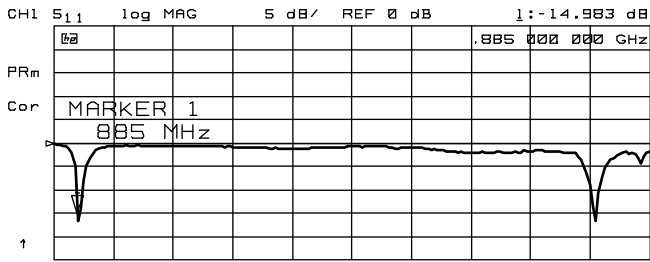

NJG1119PB4

www.DataSheet4U.com

ELECTRICAL CHARACTERISTICS 13(800MHz band Low Gain Mode)

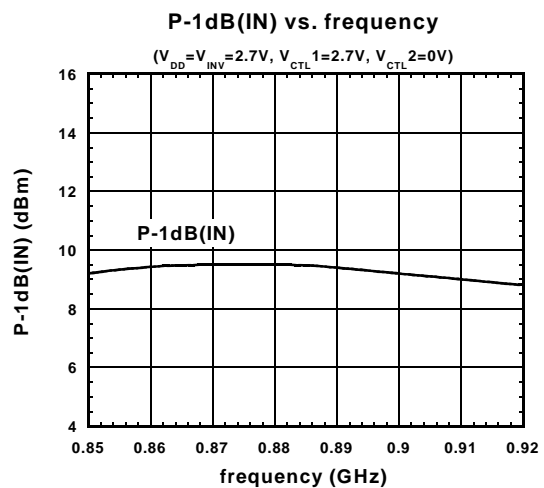
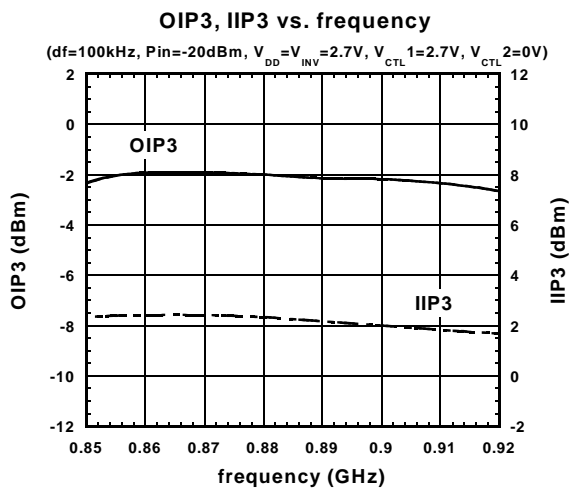
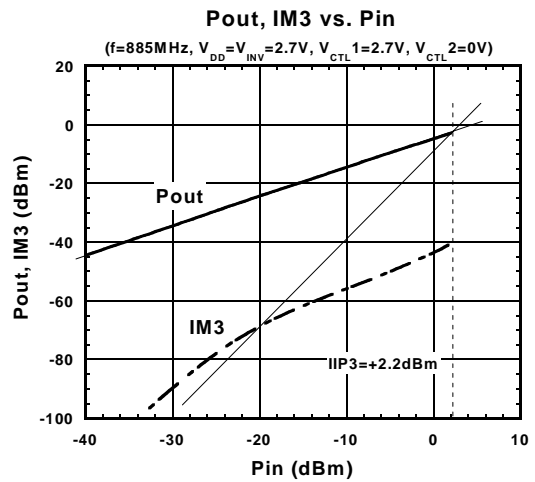
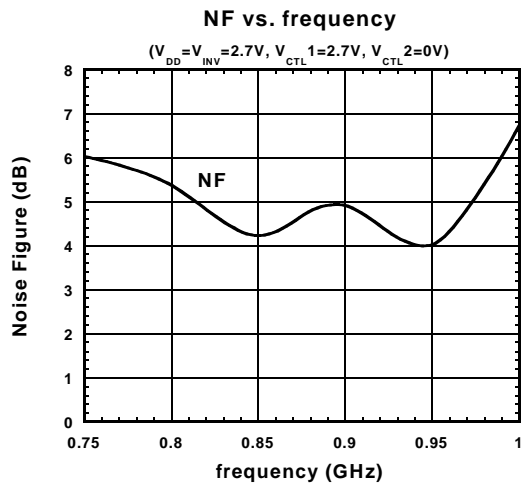
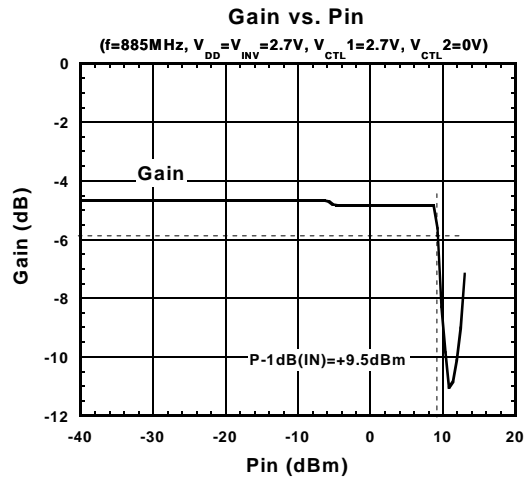
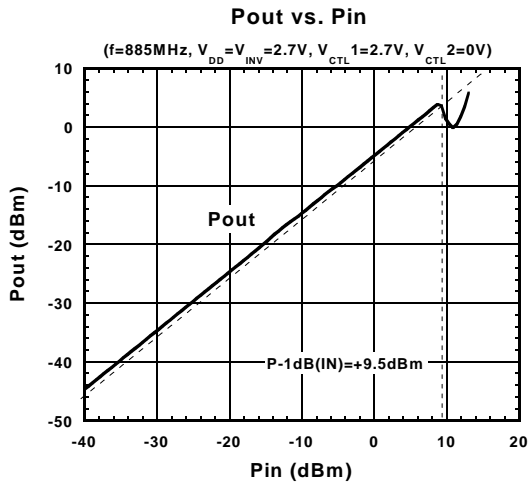

ELECTRICAL CHARACTERISTICS 14(800MHz band Low Gain Mode)

Gain, NF vs. Temperature

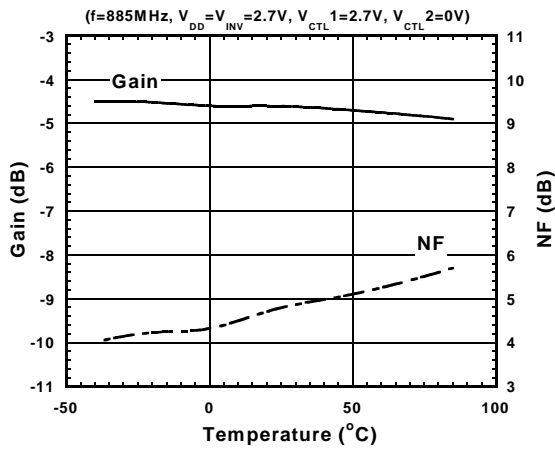

OIP3, IIP3 vs. Temperature

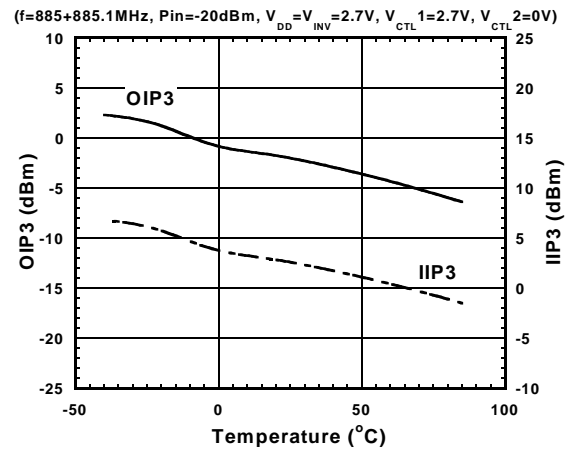

P-1dB(IN) vs. Temperature

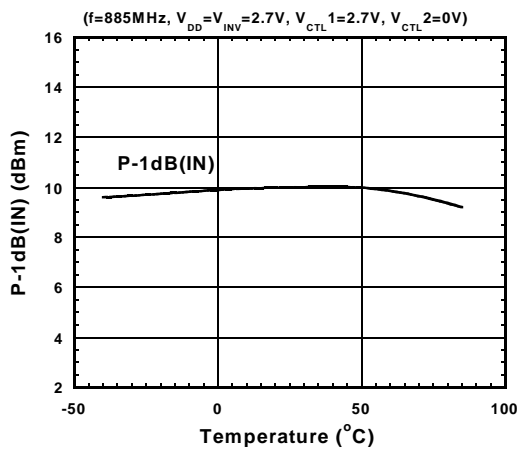

VSWR vs. Temperature

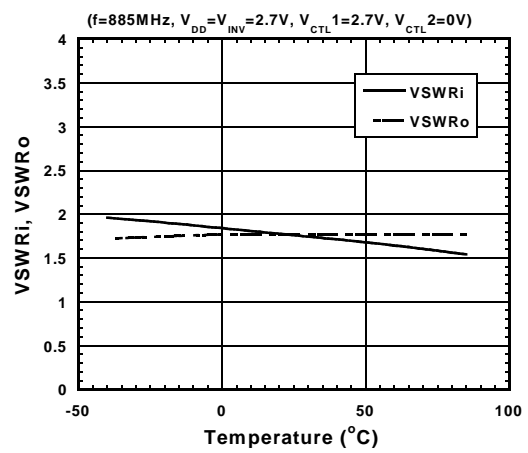

IDD vs. Temperature

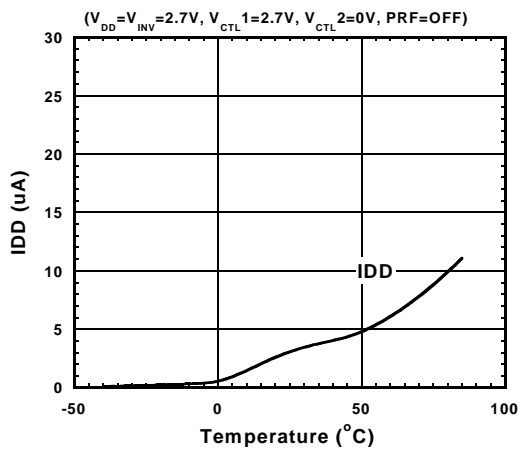

NJG1119PB4

www.DataSheet4U.com

ELECTRICAL CHARACTERISTICS 15(800MHz band Low Gain Mode)

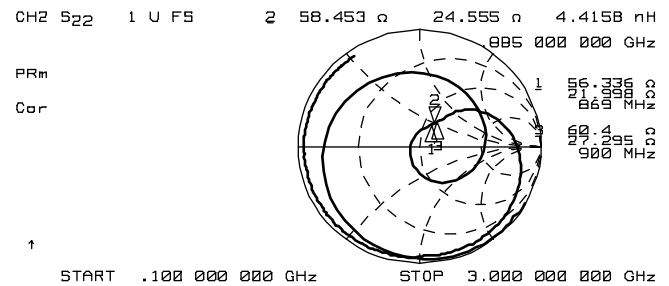
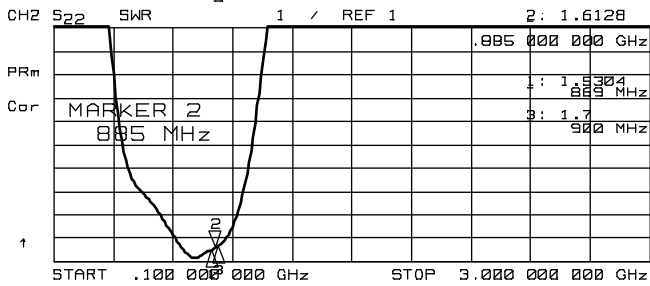
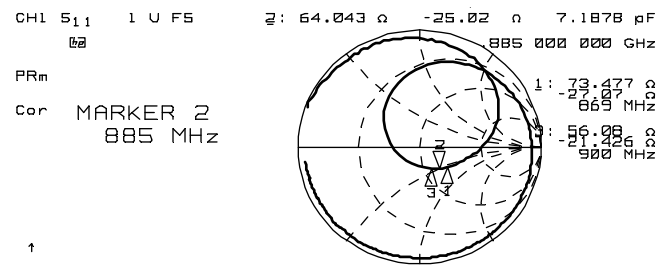
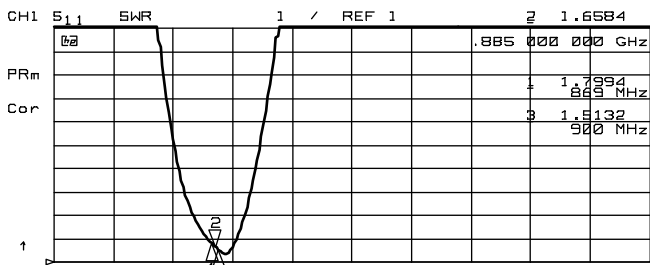
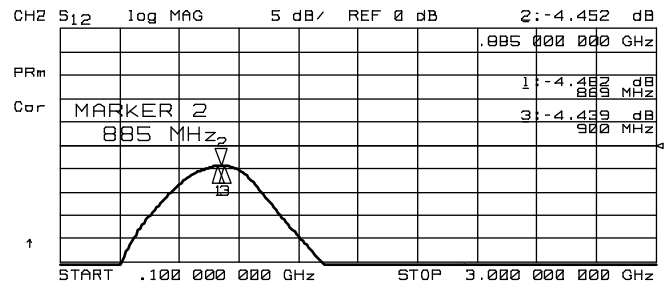
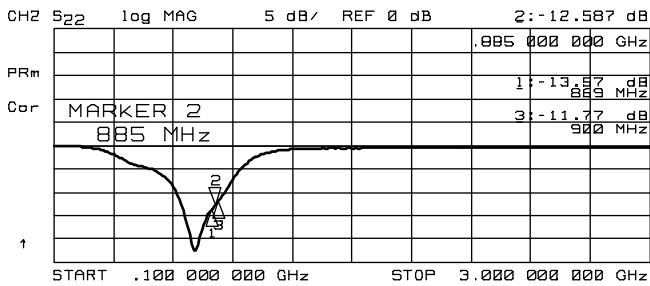
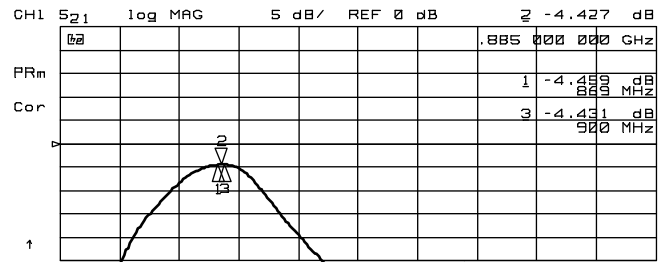
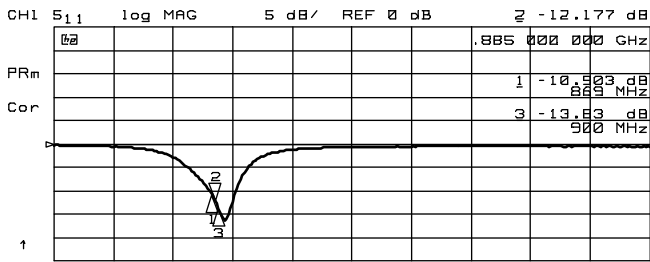

ELECTRICAL CHARACTERISTICS 16(800MHz band Low Gain Mode)

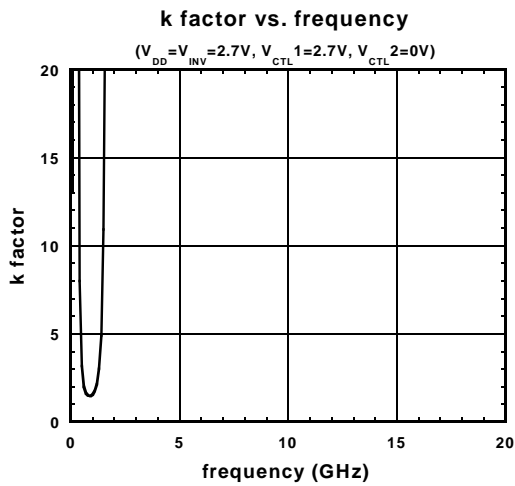
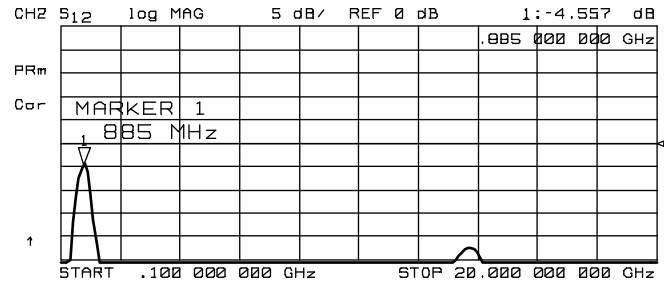
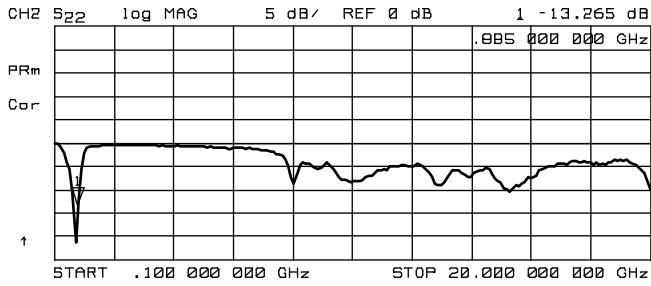
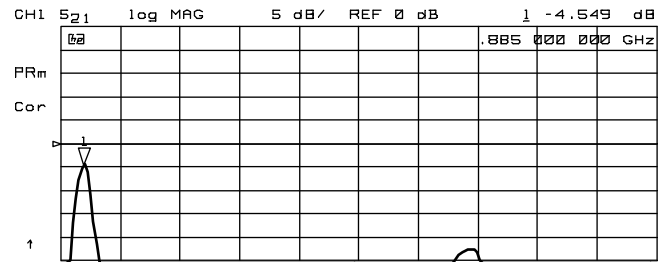
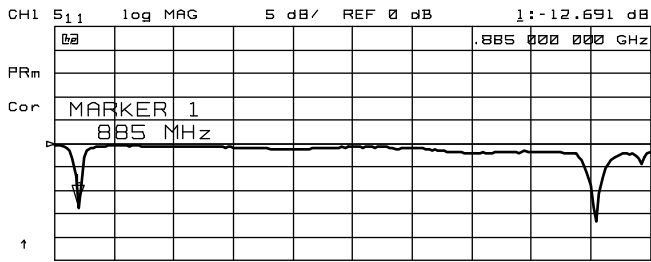

NJG1119PB4

www.DataSheet4U.com

TEST CIRCUIT

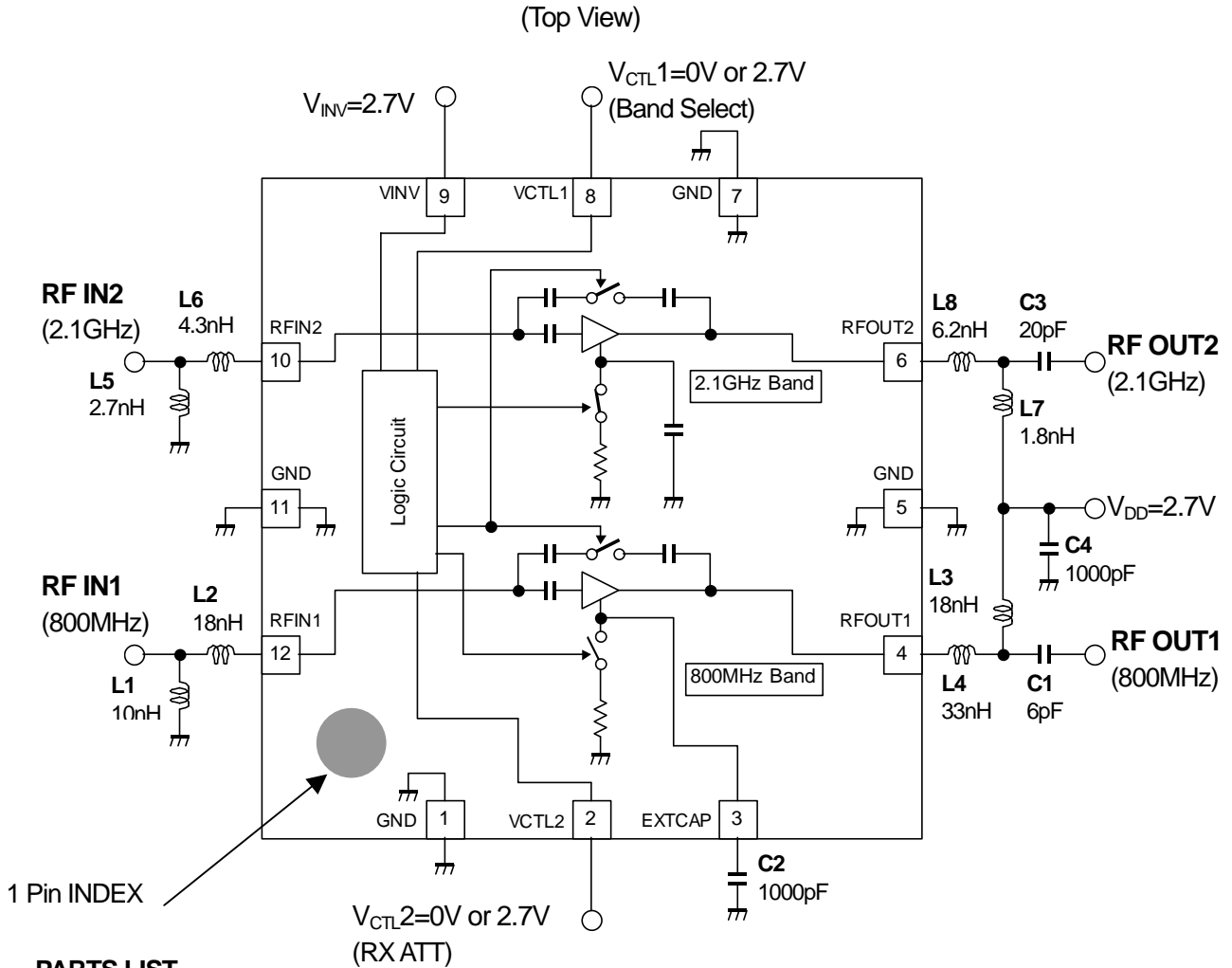

PARTS LIST

Parts ID	Comment
L1, L3~L5, L7	TAIYO-YUDEN (HK1005)
L2, L6, L8	MURATA (LQW15A)
C1~C4	MURATA (GRP15)

*: Please use an appropriate inductor for L2, L6, L8 to improve Noise Figure.

TRUTH TABLE

"H"= $V_{CTL}(H)$, "L"= $V_{CTL}(L)$

Control voltage		800MHz band		2.1GHz band	
V_{CTL1} Band select	V_{CTL2} RX ATT	LNA I_{DD}	Bypass circuit	LNA I_{DD}	Bypass circuit
L	L	OFF	ON	OFF	ON
L	H	OFF	OFF	ON	OFF
H	L	OFF	ON	OFF	ON
H	H	ON	OFF	OFF	OFF

RECOMMENDED DESIGN

(Top View)

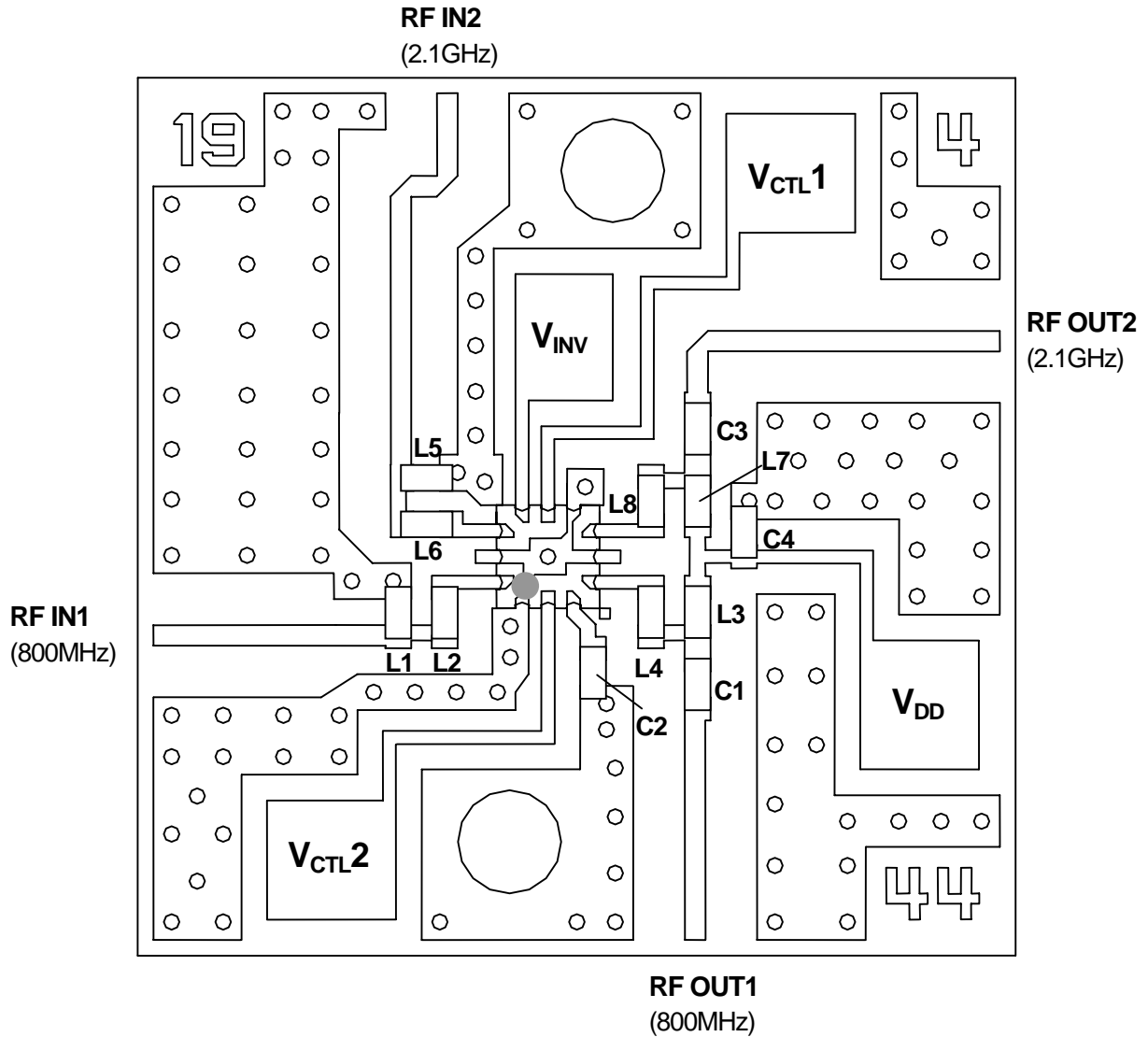

PCB (FR-4): t=0.2mm
 MICROSTRIP LINE WIDTH=0.4mm ($Z_0=50\Omega$)
 PCB SIZE=17.0mmx17.0mm

NJG1119PB4

www.DataSheet4U.com

PACKAGE OUTLINE (FFP12-B4)

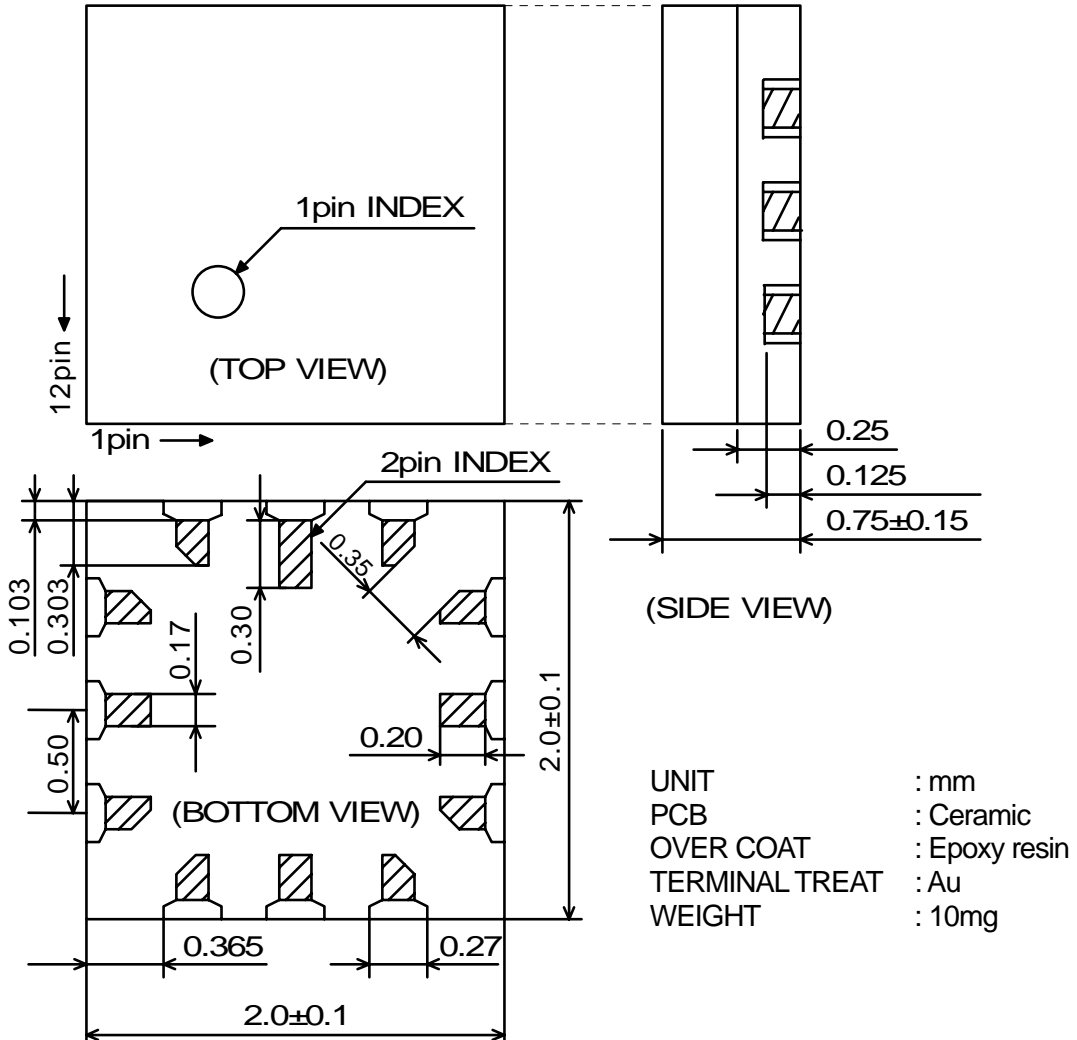

Cautions on using this product

This product contains Gallium-Arsenide (GaAs) which is a harmful material.

- Do NOT eat or put into mouth.
- Do NOT dispose in fire or break up this product.
- Do NOT chemically make gas or powder with this product.
- To waste this product, please obey the relating law of your country.

[CAUTION]

The specifications on this databook are only given for information, without any guarantee as regards either mistakes or omissions. The application circuits in this databook are described only to show representative usages of the product and not intended for the guarantee or permission of any right including the industrial rights.

This product may be damaged with electric static discharge (ESD) or spike voltage. Please handle with care to avoid these damages.