

## GNSS LOW NOISE AMPLIFIER GaAs MMIC

### ■ GENERAL DESCRIPTION

The NJG1144UX2 is a low noise amplifier GaAs MMIC designed for GPS, GALILEO, and GLONASS. The NJG1144UX2 operates from 1.5V to 3.6V supply voltage. The NJG1144UX2 achieves high gain, low noise figure and excellent input VSWR. According to adjust the external components, the NJG1144UX2 could also be used in wide frequency range from 1.0GHz to 3.0GHz. The NJG1144UX2 is available in a very small, RoHS compliant, Halogen Free, 0.65mm x 0.65mm x 0.37 mm, 4-pin EPFFP4-X2 package.

### ■ PACKAGE OUTLINE



NJG1144UX2

### ■ FEATURES

- Low voltage operation                      1.5~3.6V
- Low current consumption                    3.5mA@  $V_{DD}=2.85V$   
1.8mA@  $V_{DD}=1.8V$
- Low noise figure                              0.65dB@  $f=1575MHz, V_{DD}=2.85V$
- High gain                                        21.0dB@  $f=1575MHz, V_{DD}=2.85V$
- High input IP3                                 -2.0dBm@  $f=1575MHz, V_{DD}=2.85V$
- Package                                         EPFFP4-X2 (Package size: 0.65mm x 0.65mm x 0.37mm typ.)
- Built-in ESD Protection Diode
- RoHS compliant, Pb free, Halogen free

### ■ PIN CONFIGURATION

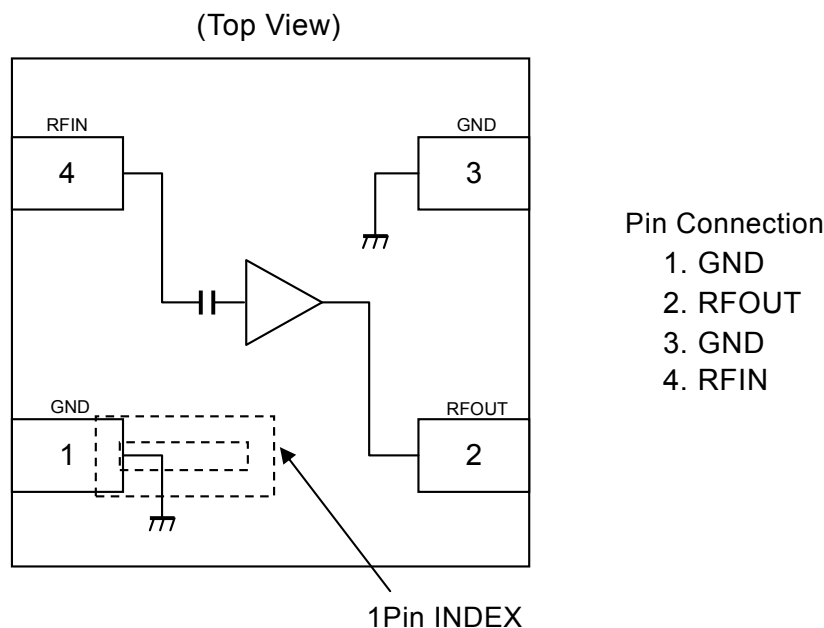

Note: Specifications and description listed in this datasheet are subject to change without notice

# NJG1144UX2

## ■ ABSOLUTE MAXIMUM RATINGS

$T_a=+25^{\circ}\text{C}$ ,  $Z_s=Z_l=50\ \text{ohm}$

PARAMETER	SYMBOL	CONDITIONS	RATINGS	UNITS
Supply voltage	$V_{DD}$		5.0	V
Input power	$P_{IN}$	$V_{DD}=2.85\text{V}$	+15	dBm
Power dissipation	$P_D$	4-layer FR4 PCB with through-hole (101.5x114.5mm), $T_j=150^{\circ}\text{C}$	250	mW
Operating temperature	$T_{opr}$		-40~+85	$^{\circ}\text{C}$
Storage temperature	$T_{stg}$		-55~+150	$^{\circ}\text{C}$

## ■ ELECTRICAL CHARACTERISTICS 1 (DC CHARACTERISTICS)

$T_a=+25^{\circ}\text{C}$

PARAMETERS	SYMBOL	CONDITIONS	MIN	TYP	MAX	UNITS
Operating voltage	$V_{DD}$		1.5	-	3.6	V
Operating current1	$I_{DD1}$	RF OFF, $V_{DD}=2.85\text{V}$	-	3.5	5.5	mA
Operating current2	$I_{DD2}$	RF OFF, $V_{DD}=1.8\text{V}$	-	1.8	3.2	mA

## ■ ELECTRICAL CHARACTERISTICS 2 (RF CHARACTERISTICS)

$V_{DD}=2.85V$ ,  $freq=1575MHz$ ,  $T_a=+25^{\circ}C$ ,  $Z_S=Z_L=50\ ohm$ , with application circuit

PARAMETERS	SYMBOL	CONDITIONS	MIN	TYP	MAX	UNITS
Small signal gain1	Gain1		18.0	21.0	23.5	dB
Noise figure1	NF1	Exclude PCB, Connector Losses (0.08dB)	-	0.65	0.95	dB
Input power 1dB gain compression1	$P_{-1dB(IN)1}$		-19.0	-16.5	-	dBm
Input 3rd order intercept point1	IIP3_1	$f1=freq$ , $f2=freq+100kHz$ , $P_{IN}=-34dBm$	-5.0	-2.0	-	dBm
Isolation1	ISL1	S12	-	-35.0	-25.0	dB
RF IN VSWR1	VSWRi1		-	1.5	2.0	-
RF OUT VSWR1	VSWRo1		-	1.5	2.2	-

## ■ ELECTRICAL CHARACTERISTICS 3 (RF CHARACTERISTICS)

$V_{DD}=1.8V$ ,  $freq=1575MHz$ ,  $T_a=+25^{\circ}C$ ,  $Z_S=Z_L=50\ ohm$ , with application circuit

PARAMETERS	SYMBOL	CONDITIONS	MIN	TYP	MAX	UNITS
Small signal gain2	Gain2		16.0	18.0	21.5	dB
Noise figure2	NF2	Exclude PCB, Connector Losses (0.08dB)	-	0.85	1.30	dB
Input power 1dB gain compression2	$P_{-1dB(IN)2}$		-22.0	-18.5	-	dBm
Input 3rd order intercept point2	IIP3_2	$f1=freq$ , $f2=freq+100kHz$ , $P_{IN}=-34dBm$	-11.0	-6.0	-	dBm
Isolation2	ISL2	S12	-	-35.0	-25.0	dB
RF IN VSWR2	VSWRi2		-	1.8	2.4	-
RF OUT VSWR2	VSWRo2		-	1.8	2.6	-

# NJG1144UX2

---

## ■ TERMINAL INFORMATION

No.	SYMBOL	DESCRIPTION
1	GND	Ground terminal (0V), Connect to the PCB ground plane.
2	RFOUT	RF output and voltage supply terminal. An external output matching circuit is required.
3	GND	Ground terminal (0V), Connect to the PCB ground plane.
4	RFIN	RF input terminal. DC blocking capacitor is not required. An external input matching circuit is required.

## ■ ELECTRICAL CHARACTERISTICS

Conditions:  $V_{DD}=2.85V$ ,  $T_a=25^\circ C$ ,  $Z_s=Z_l=50\ \text{ohm}$ , with application circuit

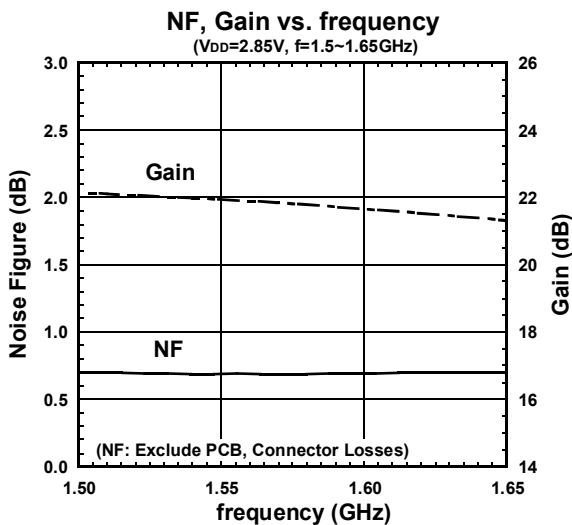
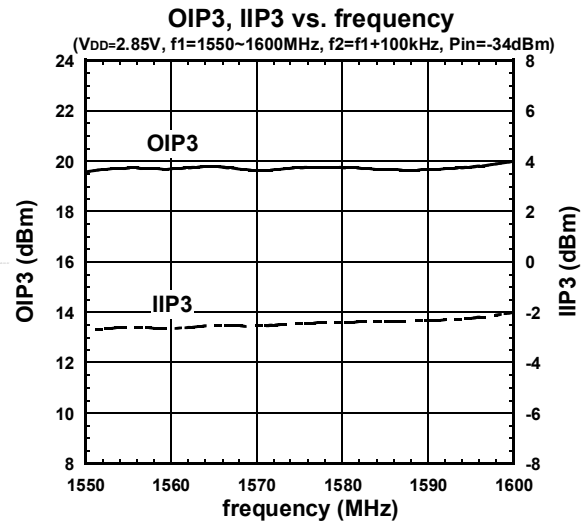
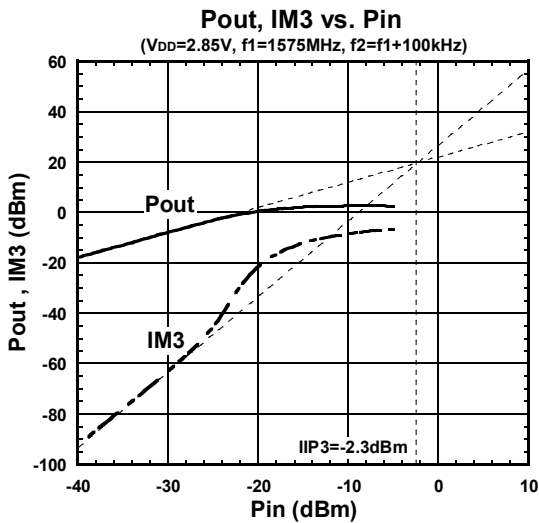
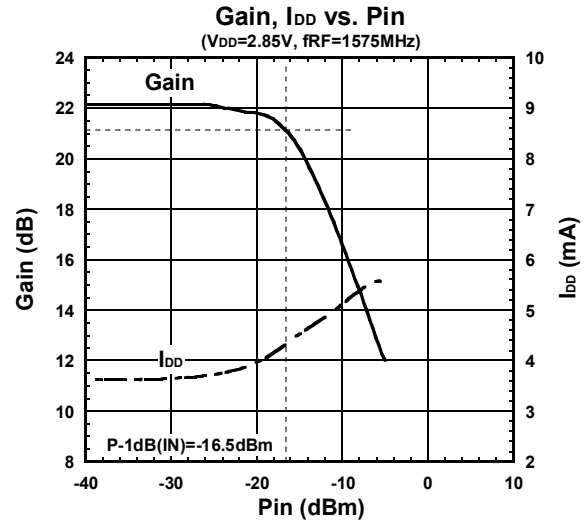
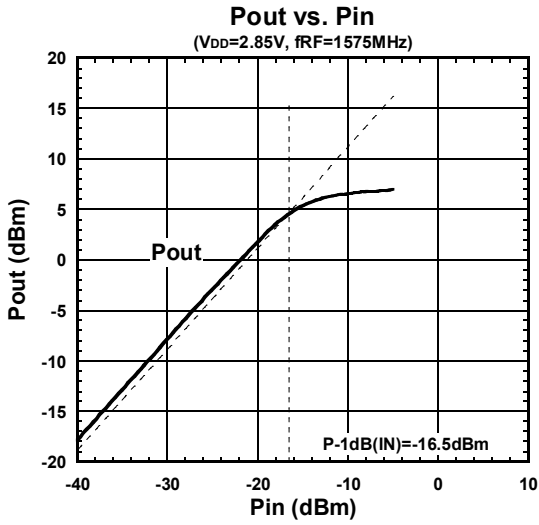

# NJG1144UX2

## ELECTRICAL CHARACTERISTICS

Conditions:  $V_{DD}=2.85V$ ,  $Z_s=Z_l=50\text{ ohm}$ , with application circuit

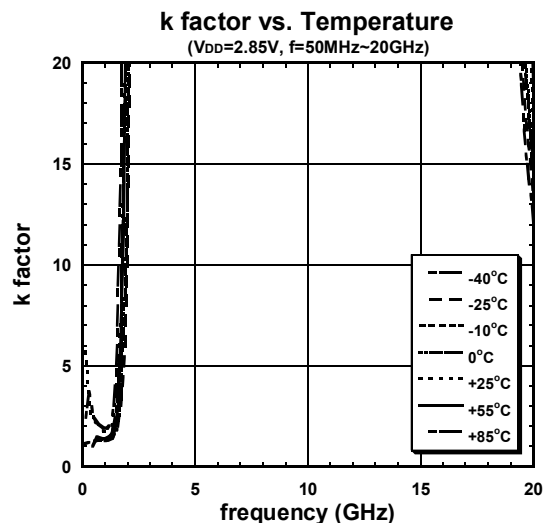
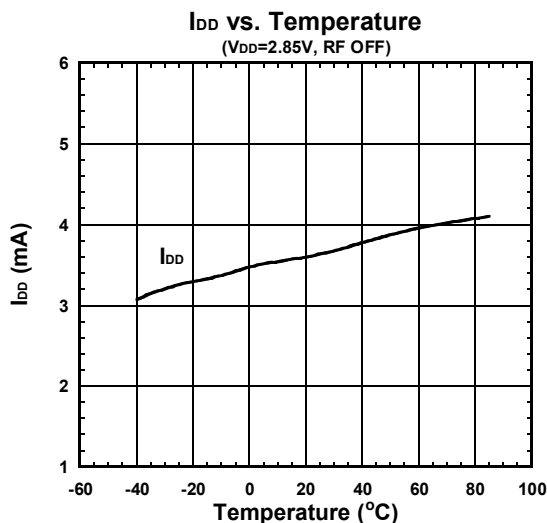
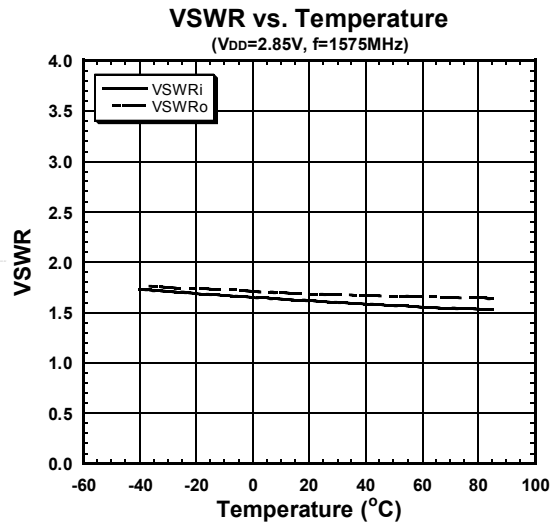
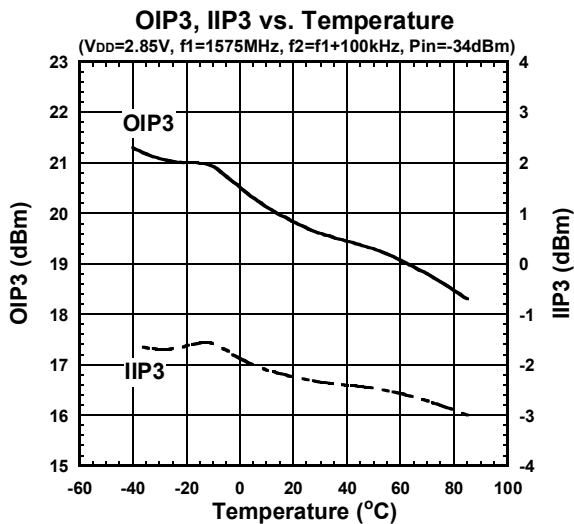
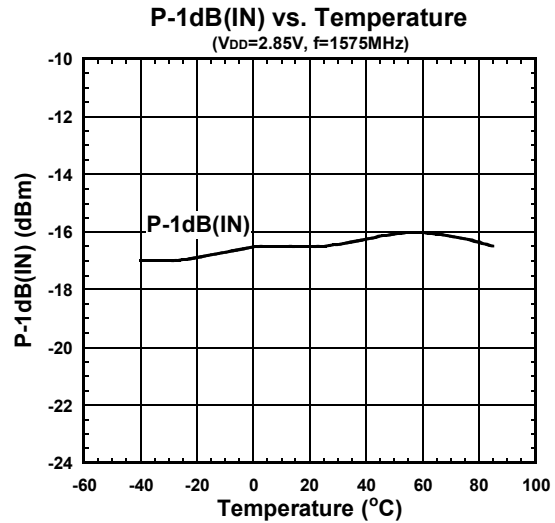
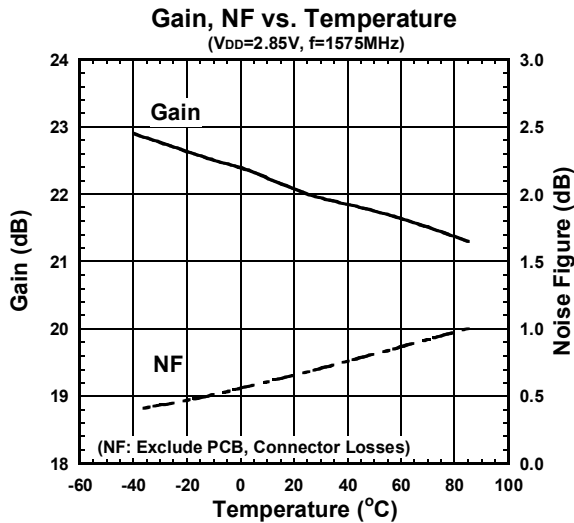

## ELECTRICAL CHARACTERISTICS

Conditions:  $V_{DD}=2.85V$ ,  $T_a=25^\circ C$ ,  $Z_s=Z_l=50\ \text{ohm}$ , with application circuit

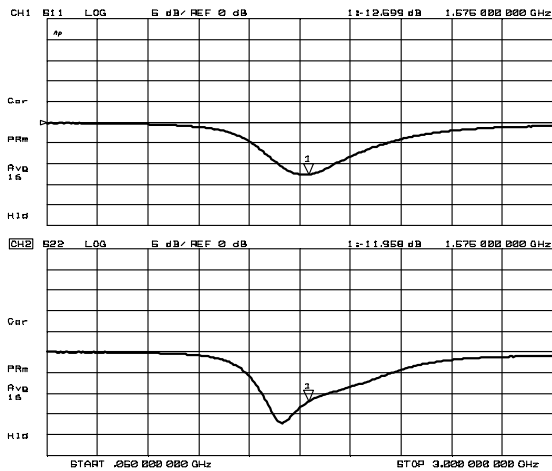

S11, S22

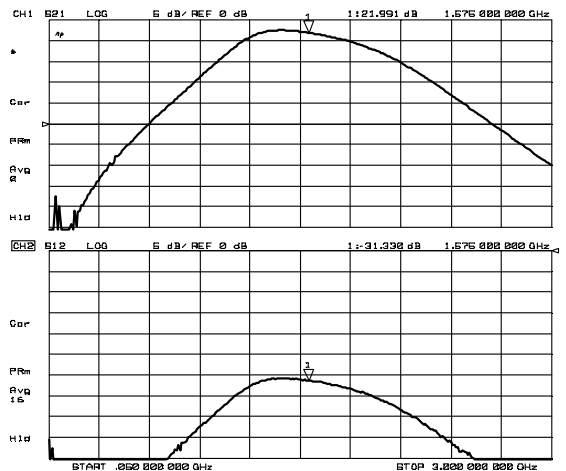

S21, S12

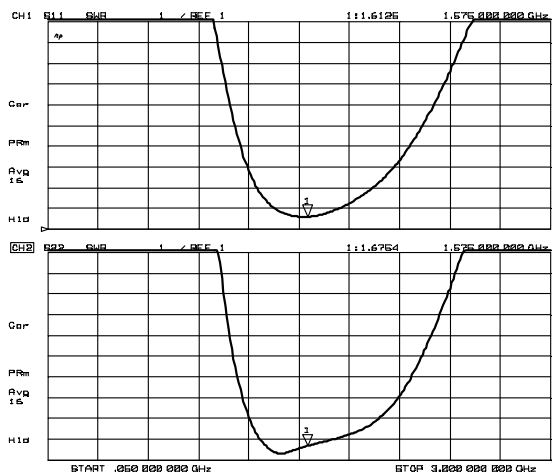

VSWRi, VSWRo

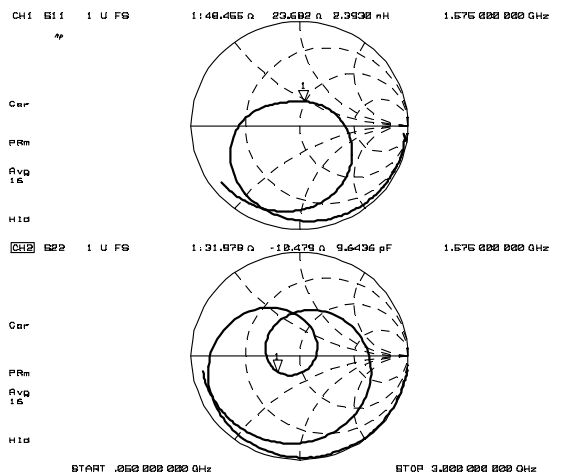

Zin, Zout

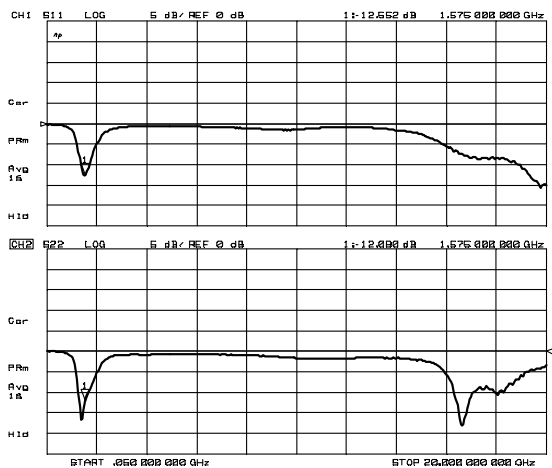

S11, S22 (50M~20GHz)

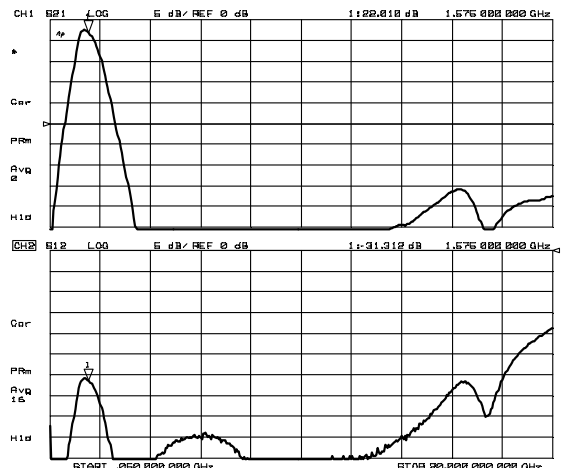

S21, S12 (50M~20GHz)

# NJG1144UX2

## ■ ELECTRICAL CHARACTERISTICS

Conditions:  $V_{DD}=1.8V$ ,  $T_a=25^\circ C$ ,  $Z_s=Z_l=50\ \text{ohm}$ , with application circuit

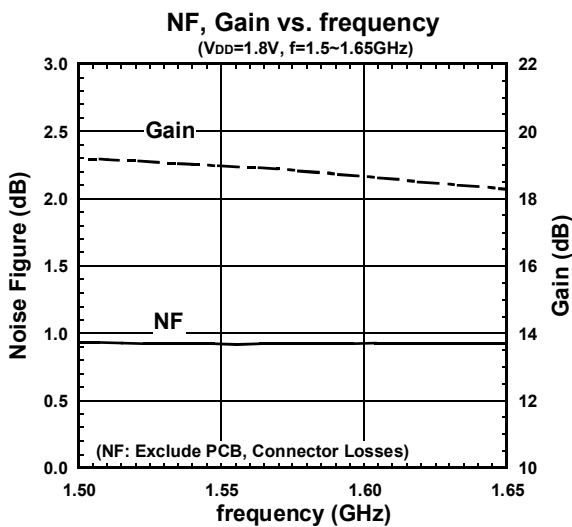
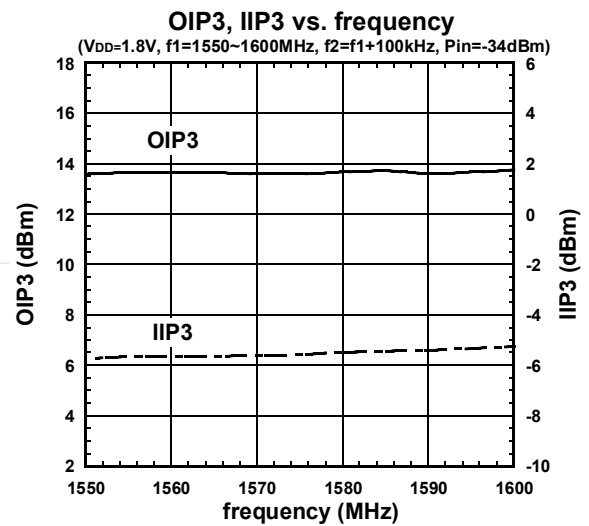
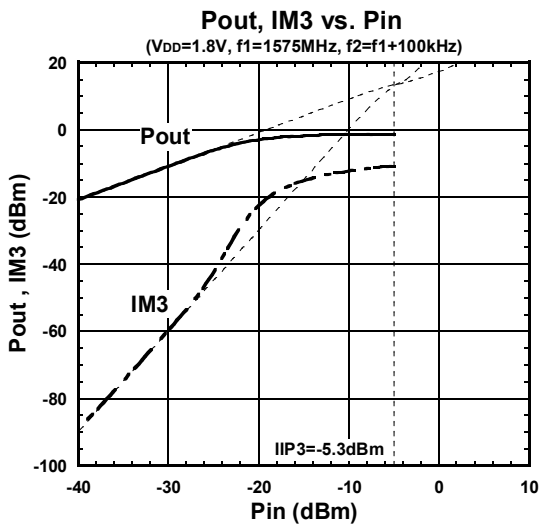
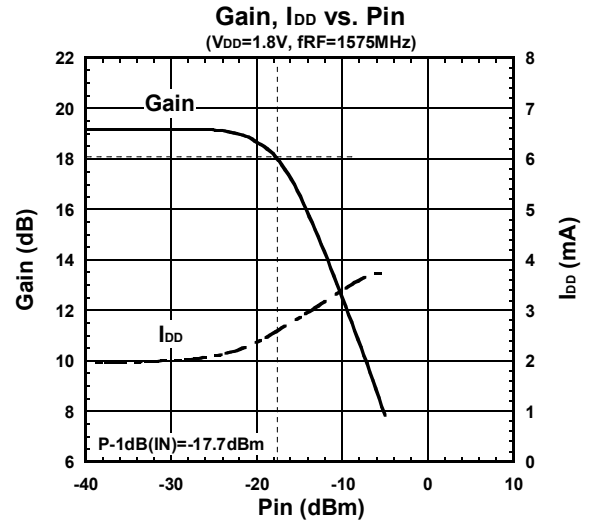
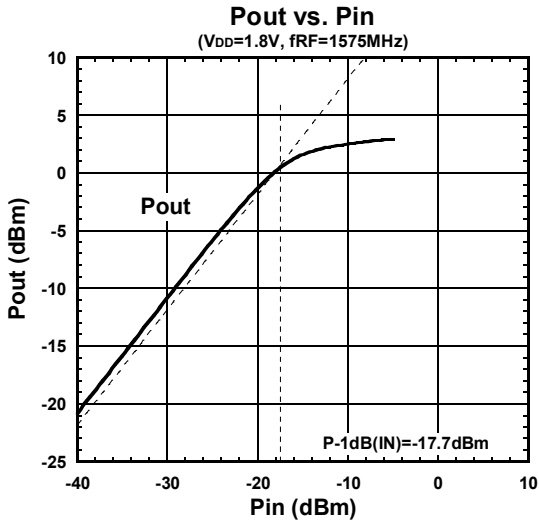



## ELECTRICAL CHARACTERISTICS

Conditions:  $V_{DD}=1.8V$ ,  $Z_s=Z_l=50\ \text{ohm}$ , with application circuit

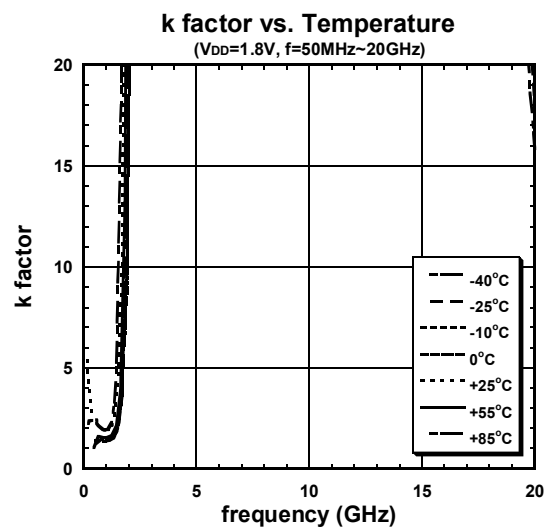
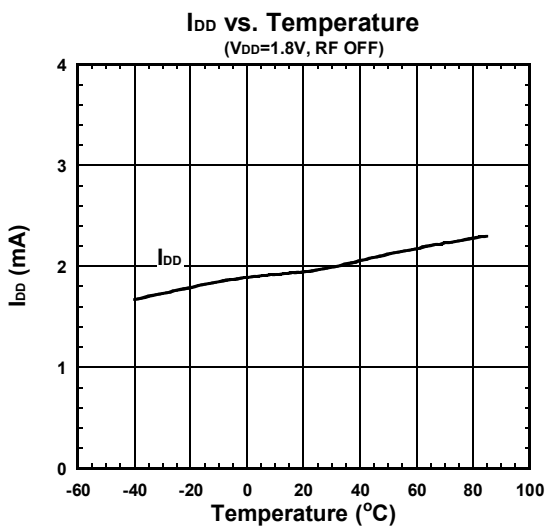
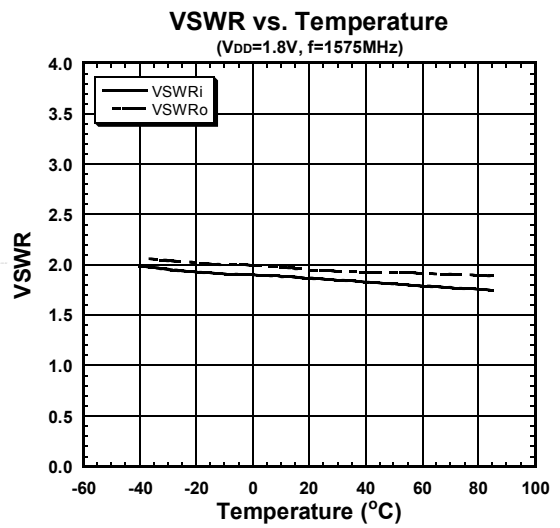
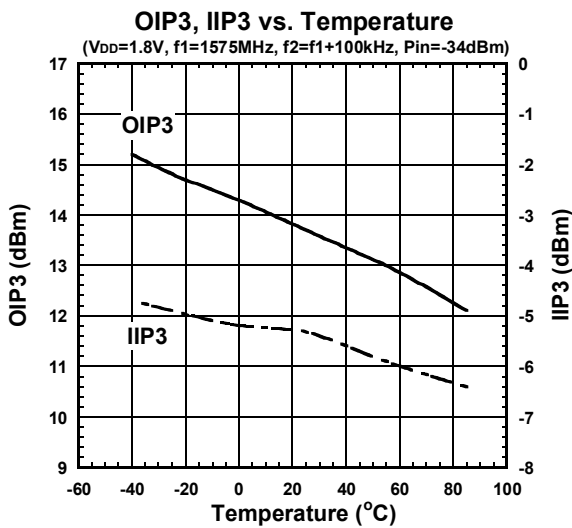
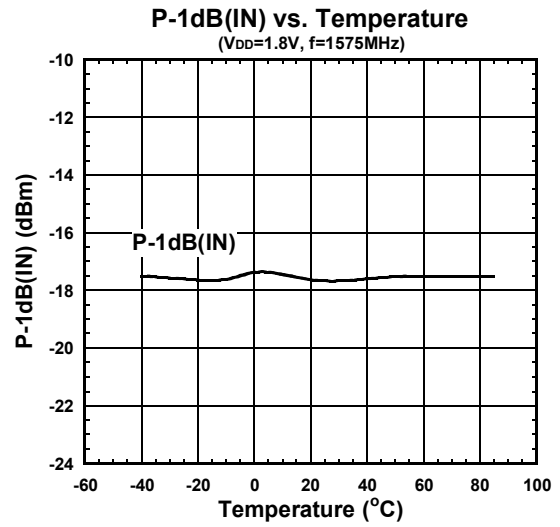
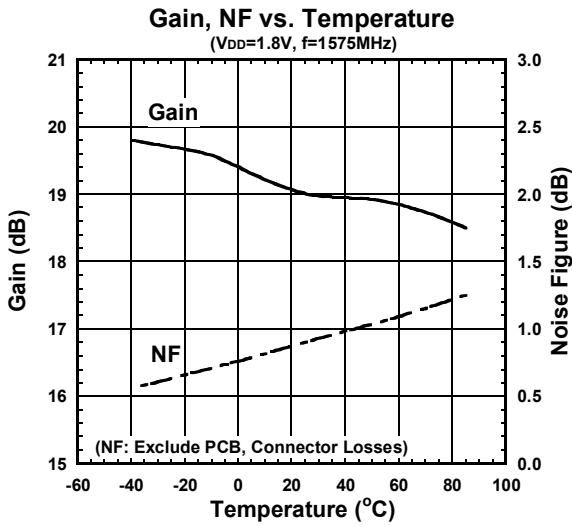

# NJG1144UX2

## ELECTRICAL CHARACTERISTICS

Conditions:  $V_{DD}=1.8V$ ,  $T_a=25^\circ C$ ,  $Z_s=Z_l=50\ \text{ohm}$ , with application circuit

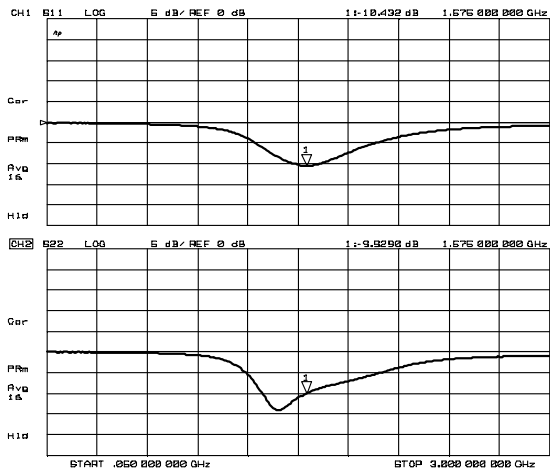

S11, S22

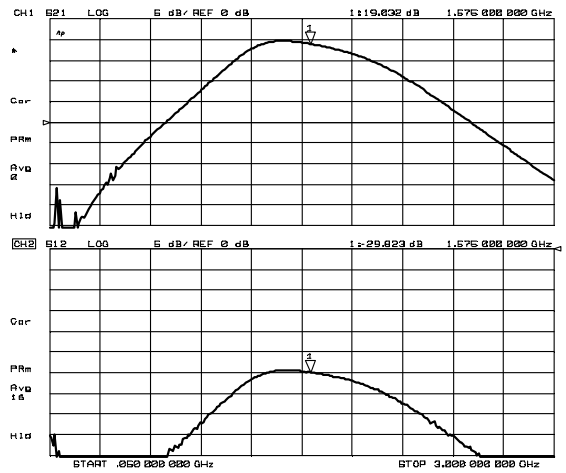

S21, S12

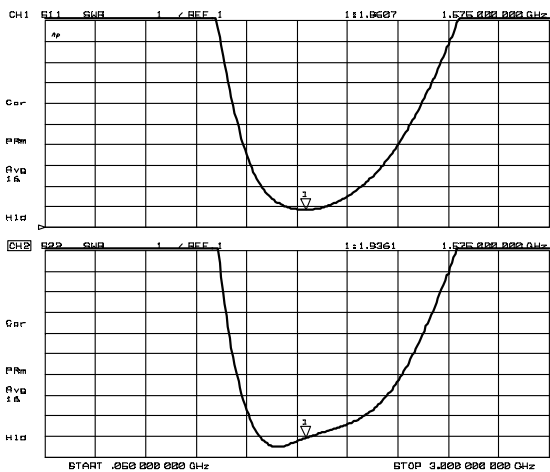

VSWRi, VSWRo

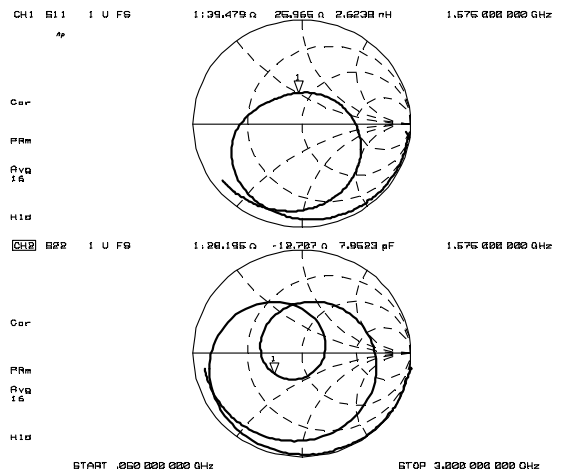

Zin, Zout

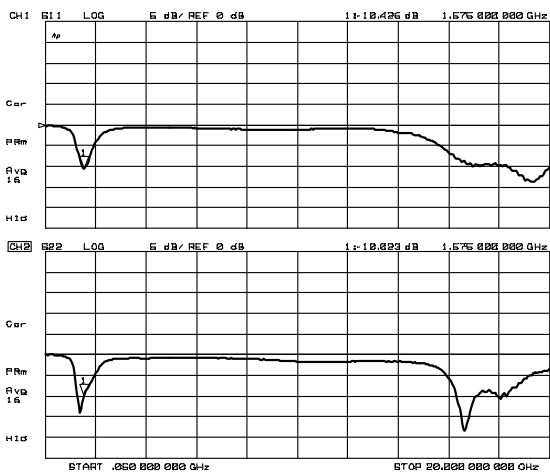

S11, S22 (50M~20GHz)

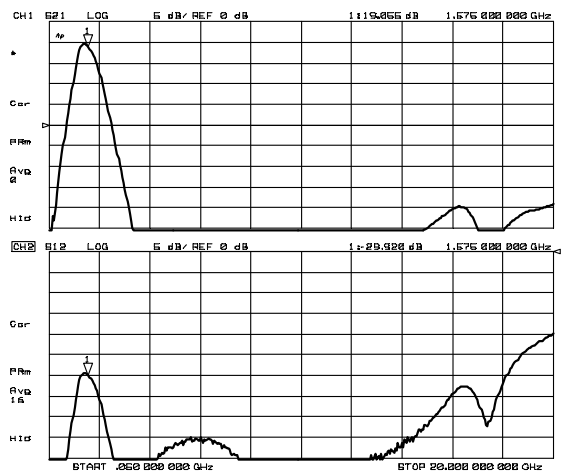

S21, S12 (50M~20GHz)

## ■ ELECTRICAL CHARACTERISTICS

Conditions:  $T_a=25^\circ\text{C}$ ,  $Z_s=Z_l=50\ \text{ohm}$ , with application circuit

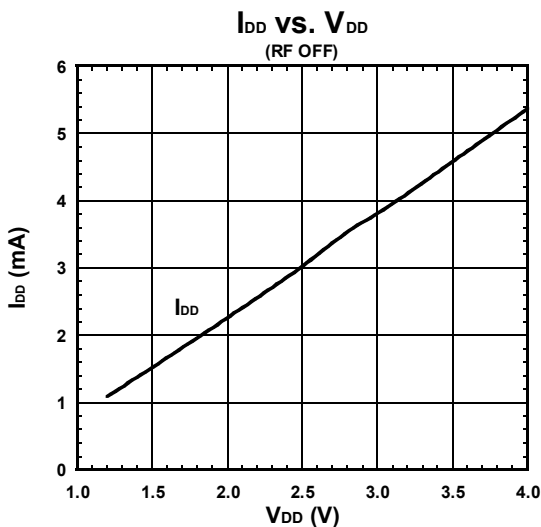
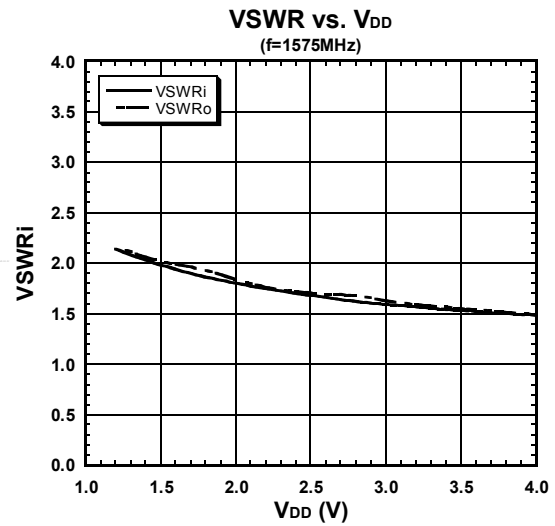
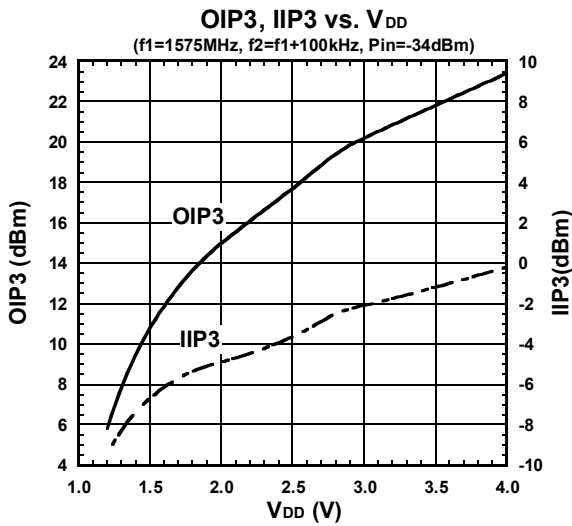
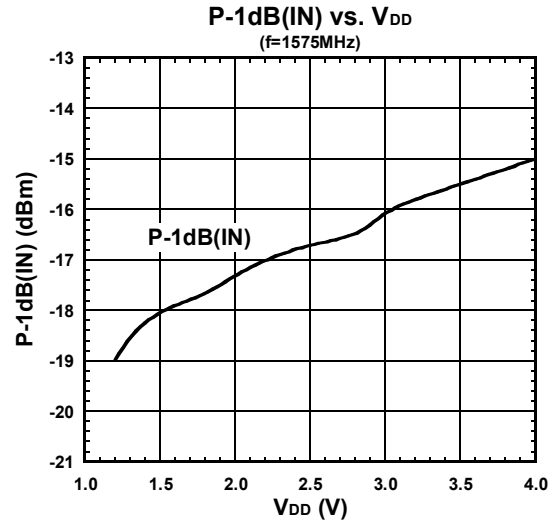
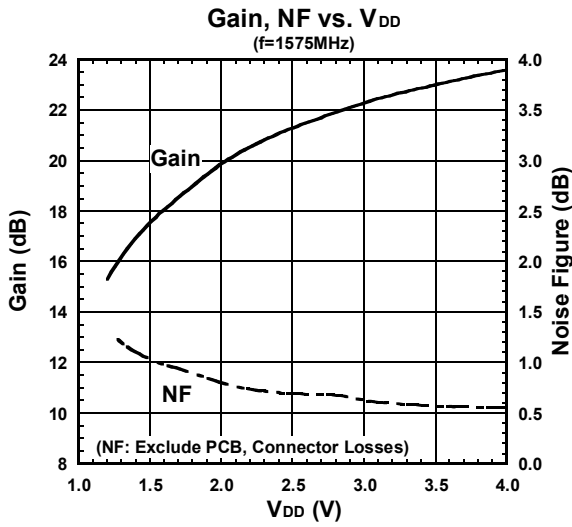



## MEASUREMENT BLOCK DIAGRAM

### Measuring instruments

NF Analyzer : Agilent 8973A, 8975A  
 Noise Source : Agilent 346A

### Setting the NF analyzer

Measurement mode form

Device under test : Amplifier  
 System downconverter : off

Mode setup form

Sideband : LSB  
 Averages : 16  
 Average mode : Point  
 Bandwidth : 4MHz  
 Loss comp : off  
 Tcold : setting the temperature of noise source (304.65K)

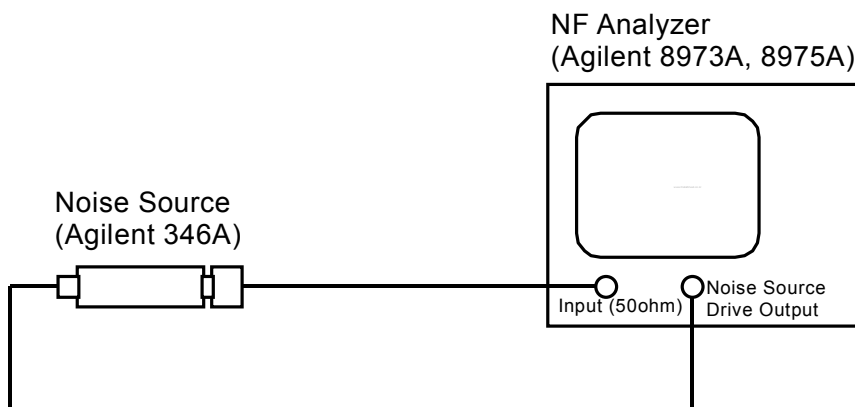

\* Noise source and NF analyzer are connected directly.

**Calibration Setup**

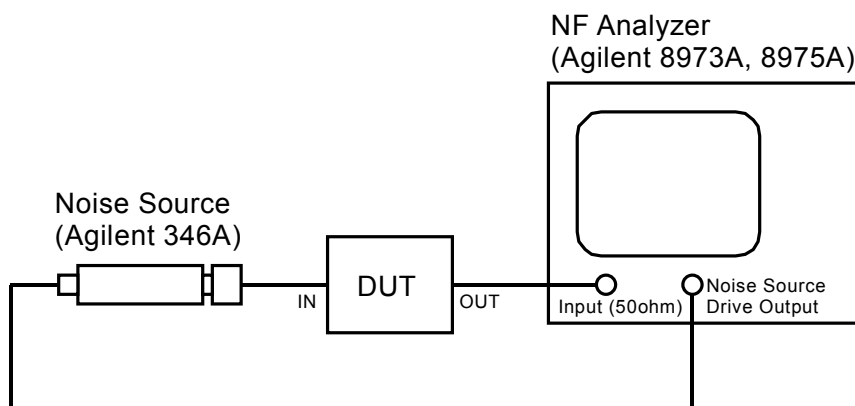

\* Noise source and DUT, DUT and NF analyzer are connected directly.

**Measurement Setup**

# NJG1144UX2

## PACKAGE OUTLINE (EPFFP4-X2)

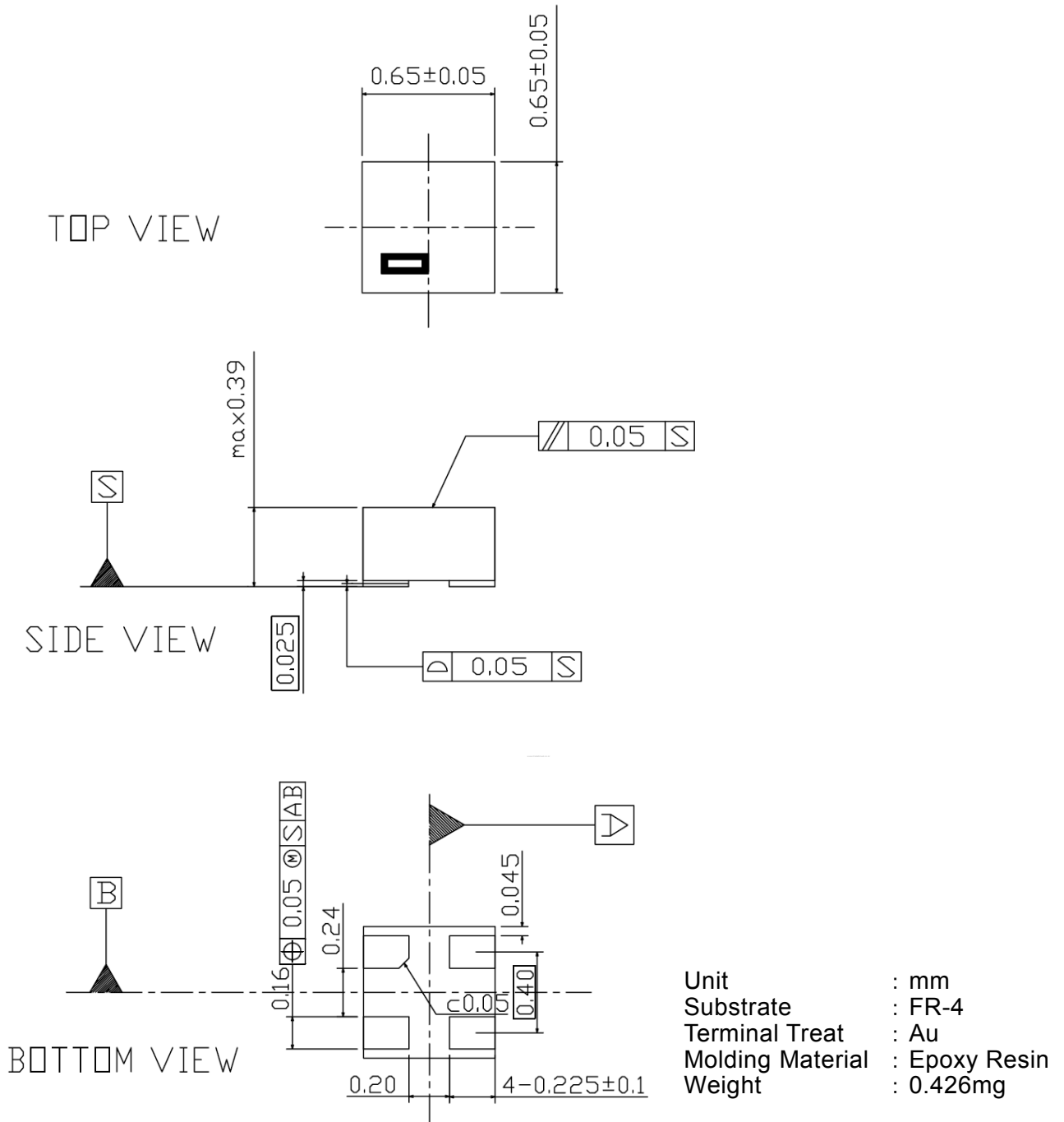

### Cautions on using this product

This product contains Gallium-Arsenide (GaAs) which is a harmful material.

- Do NOT eat or put into mouth.
- Do NOT dispose in fire or break up this product.
- Do NOT chemically make gas or powder with this product.
- To waste this product, please obey the relating law of your country.

### [CAUTION]

The specifications on this databook are only given for information, without any guarantee as regards either mistakes or omissions. The application circuits in this databook are described only to show representative usages of the product and not intended for the guarantee or permission of any right including the industrial rights.

This product may be damaged with electric static discharge (ESD) or spike voltage. Please handle with care to avoid these damages.