

5x10 DUAL BAND ANTENNA SWITCH GaAs MMIC

■GENERAL DESCRIPTION

NJG1540JA3 is a 5x10 antenna switch IC for 800MHz and 1.5GHz dual band digital cellular phone. The 7 bits parallel control signal controls RF paths between 800MHz T/R or 1.5GHz T/R circuits and internal two antennas or external two antennas. The termination ports to improve interference between diversity antennas with external matching circuits are equipped. The ultra small and thin BCC32-A3 package is applied.

■PACKAGE OUTLINE

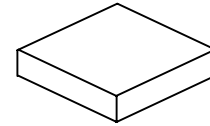

NJG1540JA3

■FEATURES

- Low voltage operation +3.3V and -2.5V (Tx only)
- Low current consumption 30uA typ. (Transmit, P_{IN}=30dBm)
15uA typ. (Receiving, No RF signal)
- Low insertion loss 0.35dB typ. @TX1-ANT1,ANT2,EXT1, f_{in}=960MHz, P_{in}=30dBm
0.55dB typ. @TX2-ANT1,ANT2,EXT1, f_{in}=1453MHz, P_{in}=30dBm
- Ultra small & thin package BCC32 (Mount Size: 5.0x5.0x0.8mm)

■PIN CONFIGURATION

BCC32 type
(Top View)

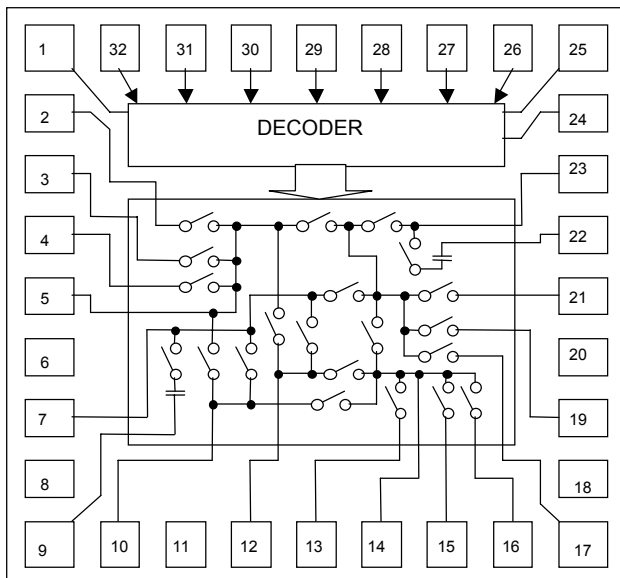

Pin Connection

- | | |
|----------------------|--------------------------|
| 1. VDD | 17. RX3(1.5GHz) |
| 2. TERM5(1.5GHz) | 18. GND |
| 3. TERM4(800MHz RX) | 19. RX2(800MHz A Band) |
| 4. TERM3(800MHz TX) | 20. GND |
| 5. ANT2 | 21. RX1(800MHz D/C Band) |
| 6. GND | 22. GND |
| 7. EXT1 | 23. EXT2 |
| 8. GND | 24. GND |
| 9. GND | 25. VSS |
| 10. TX1(800MHz) | 26. CTL7 |
| 11. GND | 27. CTL6 |
| 12. TX2(1.5GHz) | 28. CTL5 |
| 13. TERM6(800MHz TX) | 29. CTL4 |
| 14. ANT1 | 30. CTL3 |
| 15. TERM2(1.5GHz) | 31. CTL2 |
| 16. TERM1(800MHz RX) | 32. CTL1 |

NJG1540JA3

www.DataSheet4U.com

■ABSOLUTE MAXIMUM RATINGS

(T _a =+25°C)				
PARAMETER	SYMBOL	CONDITIONS	RATINGS	UNITS
Supply Voltage 1	V _{DD}	VDD Terminal	6.0	V
Supply Voltage 2	V _{SS}	VSS Terminal	-4.0~+0.3	V
Control Voltage	V _{CTL}	CTL1~7 Terminals	6.0	V
Input Power	P _{IN}	TX1, TX2, ANT1, ANT2, EXT1 Terminals	36	dBm
		RX1, RX2, RX3, EXT2 Terminals	28	dBm
Power Dissipation	P _D		950	mW
Operating Temperature	T _{opr}		-25~+75	°C
Storage Temperature	T _{stg}		-55~+125	°C

■ELECTRICAL CHARACTERISTICS 1 [DC CHARACTERISTICS]

General Conditions: T_a=+25°C, V_{DD}=3.3V, V_{SS}=-2.5V

TX1, TX2, RX1, RX2, RX3, ANT1, ANT2, EXT1, EXT2: terminated (50Ω)

TER1~6: grounded by 5pF capacitor.

PARAMETER	SYMBOL	CONDITIONS	MIN	TYP	MAX	UNITS
Positive Supply Voltage	V _{DD}	V _{DD} Terminal	2.7	3.3	5.0	V
Negative Supply Voltage	V _{SS}	V _{SS} Terminal	-3.5	-2.5	-2.0	V
Current Consumption 1	I _{DD1}	V _{DD} Terminal RX Mode, No RF Signal	-	15	30	μA
Current Consumption 2	I _{SS1}	V _{SS} Terminal RX Mode, No RF Signal	-0.1	-	0	μA
Current Consumption 3	I _{DD2}	V _{DD} Terminal f _{in} =0.05~2GHz TX Mode, P _{in} =30dBm	-	50	100	μA
Current Consumption 4	I _{SS2}	V _{SS} Terminal, f _{in} =0.05~2GHz TX Mode, P _{in} =30dBm	-100	-50	-	μA
Control Voltage (H)	V _{CTL(H)}	CTL1~7 Terminal	2.0	3.0	V _{DD}	V
Control Voltage (L)	V _{CTL(L)}	CTL1~7 Terminal	0	0	0.6	V
Control Current	I _{CTL}	CTL1~7 Terminal=V _{DD} or CTL1~7 Terminal=0V	-1.3	-	1.3	μA
Control terminal Input Impedance	R _{in}	CTL1~7 Terminal	4	-	-	MΩ

■ ELECTRICAL CHARACTERISTICS 2 [800MHz TX Mode]

General Conditions: $T_a=+25^{\circ}\text{C}$, $V_{DD}=3.3\text{V}$, $V_{SS}=0\text{V}$, $f_{in}=893\sim 960\text{MHz}$

Tested on PCB circuit as shown below.

Insertion loss of each connectors, striplines, and capacitors are excluded.

TX1, TX2, RX1, RX2, RX3, ANT1, ANT2, EXT1, and EXT2: terminated (50Ω)

TER1~6: grounded by 5pF capacitor

PARAMETER	SYMBOL	CONDITONS	MIN	TYP	MAX	UNITS
TX1-ANT1 Insertion Loss	LOSS1	$P_{in}=30\text{dBm}$	-	0.35	0.50	dB
TX1-ANT2 Insertion Loss	LOSS2	$P_{in}=30\text{dBm}$	-	0.35	0.50	dB
TX1-EXT1 Insertion Loss	LOSS3	$P_{in}=30\text{dBm}$	-	0.35	0.50	dB
TX1-RX1, RX2, RX3 Isolation	ISL1	$P_{in}=30\text{dBm}$ TX1-ANT1, ANT2, EXT1 passing	40	45	-	dB
TX1-EXT1 Isolation	ISL2	$P_{in}=30\text{dBm}$ TX1-ANT1, ANT2 passing	23	25	-	dB
TX1-ANT1 Isolation	ISL3	$P_{in}=30\text{dBm}$ TX1-ANT2, EXT1 passing	25	30	-	dB
TX1-ANT2 Isolation	ISL4	$P_{in}=30\text{dBm}$ TX1-ANT1, EXT1 passing	25	30	-	dB
TX1-EXT2 Isolation	ISL5	$P_{in}=30\text{dBm}$ TX1-ANT1, ANT2, EXT1 passing	25	30	-	dB
Input Power at 0.1dB Compression 1	$P_{-0.1\text{dB}}(1)$	TX1-ANT1, ANT2, EXT1 passing	33.0	34.5	-	dBm
Adjacent Channel Leakage Power 1	ACP1	PDC Standard, $\pm 50\text{kHz}$ offset $P_{in}=30\text{dBm}$, Load: $\text{VSWR}=1.5$ Input Signal ACP=-70dBc @ 30dBm	-	-65	-63	dBc
Adjacent Channel Leakage Power 2	ACP2	PDC Standard, $\pm 50\text{kHz}$ offset, $P_{in}=30\text{dBm}$, Load: $\text{VSWR} \leq 3.0$ Input Signal ACP=-70dBc @ 30dBm	-	-65	-55	dBc
Adjacent Channel Leakage Power 3	ACP3	PDC Standard, $\pm 50\text{kHz}$ offset, $V_{DD} \geq 3.0\text{V}$ $P_{in}=30\text{dBm}$, Load: $\text{VSWR} \leq 1.5$ Input Signal ACP=-70dBc @ 30dBm	-	-65	-60	dBc
Adjacent Channel Leakage Power 4	ACP4	PDC Standard, $\pm 100\text{kHz}$ offset $V_{DD} \geq 3.0\text{V}$ $P_{in}=30\text{dBm}$, Load: $\text{VSWR} \leq 1.5$ Input Signal ACP=-76dBc @ 30dBm	-	-73	-65	dBc
2nd Harmonics 1	$2f_0(1)$	$P_{in}=30\text{dBm}$ $V_{DD} \geq 3.0\text{V}$, Load: $\text{VSWR} \leq 1.5$ Input Signal 2nd Harmonics=-70dBc	-	-70	-65	dBc
3rd Harmonics 1	$3f_0(1)$	$P_{in}=30\text{dBm}$ $V_{DD} \geq 3.0\text{V}$, Load: $\text{VSWR} \leq 1.5$ Input Signal 3rd Harmonics=-100dBc	-	-65	-63	dBc
VSWR 1	VSWR1	TX1-ANT1, ANT2, EXT1 passing	-	1.2	1.4	
Switching Time 1	T_{D1}	CTL1~7	-	200	500	nsec

NJG1540JA3

www.DataSheet4U.com

■ ELECTRICAL CHARACTERISTICS 3 [800MHz RX Mode]

General Conditions: $T_a=+25^{\circ}\text{C}$, $V_{DD}=3.3\text{V}$, $V_{SS}=0\text{V}$, $f_{in}=810\sim 885\text{MHz}$

Tested on PCB circuit as shown below.

Insertion loss of each connectors, striplines, and capacitors are excluded.

TX1, TX2, RX1, RX2, RX3, ANT1, ANT2, EXT1, and EXT2: terminated (50Ω)

TER1~6: grounded by 5pF capacitor

PARAMETER	SYMBOL	CONDITIONS	MIN	TYP	MAX	UNITS
RX1,2-ANT1 Insertion Loss	LOSS4	$P_{in}=10\text{dBm}$	-	0.85	1.00	dB
RX1,2-ANT2 Insertion Loss	LOSS5	$P_{in}=10\text{dBm}$	-	0.85	1.00	dB
RX1,2-EXT1 Insertion Loss	LOSS6	$P_{in}=10\text{dBm}$	-	0.95	1.10	dB
RX1,2-EXT2 Insertion Loss	LOSS7	$P_{in}=10\text{dBm}$	-	1.05	1.20	dB
RX1-RX2 Isolation	ISL6	$P_{in}=10\text{dBm}$, $f=658\text{MHz}$ RX1,2-ANT1,2,EXT1,2 passing	23	25	-	dB
RX1,2-ANT1 Isolation	ISL7	$P_{in}=10\text{dBm}$ RX1,2-ANT2,EXT1,EXT2 passing	23	25	-	dB
RX1,2-ANT2 Isolation	ISL8	$P_{in}=10\text{dBm}$ RX1,2-ANT1,EXT1,EXT2 passing	25	30	-	dB
RX1,2-EXT1 Isolation	ISL9	$P_{in}=10\text{dBm}$ RX1,2-ANT1,ANT2,EXT2 passing	23	27	-	dB
RX1,2-EXT2 Isolation	ISL10	$P_{in}=10\text{dBm}$ RX1,2-ANT1,ANT2,EXT1 passing	25	30	-	dB
Input Power at 0.5dB Compression 1	$P_{-0.5(1)}$	RX1,2-ANT1,ANT2,EXT1,EXT2 passing	25	28	-	dBm
VSWR 2	VSWR2	RX1,2-ANT1,ANT2,EXT1,EXT2 passing	-	1.3	1.5	
Switching Time2	T_{D2}	CTL1~7	-	200	500	nsec

■ELECTRICAL CHARACTERISTICS 4 [1.5GHz TX Mode]

General Conditions: $T_a=+25^{\circ}\text{C}$, $V_{DD}=3.3\text{V}$, $V_{SS}=0\text{V}$, $f_{in}=1429\sim 1453\text{MHz}$

Tested on PCB circuit as shown below.

Insertion loss of each connectors, striplines, and capacitors are excluded.

TX1, TX2, RX1, RX2, RX3, ANT1, ANT2, EXT1, and EXT2: terminated (50Ω)

TER1~6: grounded by 5pF capacitor

PARAMETER	SYMBOL	CONDITONS	MIN	TYP	MAX	UNITS
TX2-ANT1 Insertion Loss	LOSS8	$P_{in}=30\text{dBm}$	-	0.55	0.70	dB
TX2-ANT2 Insertion Loss	LOSS9	$P_{in}=30\text{dBm}$	-	0.55	0.70	dB
TX2-EXT1 Insertion Loss	LOSS10	$P_{in}=30\text{dBm}$	-	0.55	0.70	dB
TX2-RX1,RX2,RX3 Isolation	ISL11	$P_{in}=30\text{dBm}$ TX2-ANT1, ANT2, EXT1 passing	40	45	-	dB
TX2-EXT1 Isolation	ISL12	$P_{in}=30\text{dBm}$ TX2-ANT1 ANT2, passing	23	25	-	dB
TX2-ANT1 Isolation	ISL13	$P_{in}=30\text{dBm}$ TX2- ANT2, EXT1 passing	23	25	-	dB
TX2-ANT2 Isolation	ISL14	$P_{in}=30\text{dBm}$ TX2-ANT1, EXT1 passing	23	25	-	dB
TX2-EXT2 Isolation	ISL15	$P_{in}=30\text{dBm}$ TX2-ANT1, ANT2, EXT1 passing	25	30	-	dB
Input Power at 0.1dB Compression. 2	$P_{-0.1(2)}$	TX2-ANT1, ANT2,EXT1 passing	33.0	34.5	-	dBm
Adjacent Channel Leakage Power 5	ACP5	PDC Standard, $\pm 50\text{kHz}$ offset $P_{in}=30\text{dBm}$, Load: $V_{SWR}=1.5$ Input Signal ACP=-68dBc @ 30dBm	-	-65	-63	dBc
Adjacent Channel Leakage Power 6	ACP6	PDC Standard, $\pm 50\text{kHz}$ offset, $P_{in}=30\text{dBm}$, Load: $V_{SWR} \leq 3.0$ Input Signal ACP=-68dBc @ 30dBm	-	-62	-55	dBc
Adjacent Channel Leakage Power 7	ACP7	PDC Standard, $\pm 50\text{kHz}$ offset, $V_{DD} \geq 3.0\text{V}$ $P_{in}=30\text{dBm}$, Load: $V_{SWR} \leq 1.5$ Input Signal ACP=-68dBc @ 30dBm	-	-65	-60	dBc
Adjacent Channel Leakage Power 8	ACP8	PDC Standard, $\pm 100\text{kHz}$ offset $V_{DD} \geq 3.0\text{V}$ $P_{in}=30\text{dBm}$, Load: $V_{SWR} \leq 1.5$ Input Signal ACP=-76dBc @ 30dBm	-	-70	-65	dBc
2nd Harmonics 2	$2f_0(2)$	$P_{in}=30\text{dBm}$ $V_{DD} \geq 3.0\text{V}$, Load: $V_{SWR} \leq 1.5$ Input Signal 2nd Harmonics=-80dBc	-	-68	-65	dBc
3rd Harmonics 2	$3f_0(2)$	$P_{in}=30\text{dBm}$ $V_{DD} \geq 3.0\text{V}$, Load: $V_{SWR} \leq 1.5$ Input Signal 3rd Harmonics=-100dBc	-	-60	-57	dBc
VSWR3	VSWR3	TX2-ANT1, ANT2,EXT1 passing	-	1.2	1.4	
Switching Time3	T_{D3}	CTL1~7	-	200	500	nsec

NJG1540JA3

www.DataSheet4U.com

■ELECTRICAL CHARACTERISTICS 5 [1.5GHz RX Mode]

General Conditions: $T_a=+25^{\circ}\text{C}$, $V_{DD}=3.3\text{V}$, $V_{SS}=0\text{V}$, $f_{in}=1477\sim 1501\text{MHz}$

Tested on PCB circuit as shown below.

Insertion loss of each connectors, striplines, and capacitors are excluded.

TX1, TX2, RX1, RX2, RX3, ANT1, ANT2, EXT1, and EXT2: terminated (50Ω)

TER1~6: grounded by 5pF capacitor

PARAMETER	SYMBOL	CONDITONS	MIN	TYP	MAX	UNITS
RX3-ANT1 Insertion Loss	LOSS11	$P_{in}=10\text{dBm}$	-	1.00	1.15	dB
RX3-ANT2 Insertion Loss	LOSS12	$P_{in}=10\text{dBm}$	-	1.10	1.25	dB
RX3-EXT1 Insertion Loss	LOSS13	$P_{in}=10\text{dBm}$	-	1.10	1.25	dB
RX3-EXT2 Insertion Loss	LOSS14	$P_{in}=10\text{dBm}$	-	1.00	1.15	dB
RX3-ANT1 Isolation	ISL16	$P_{in}=10\text{dBm}$ RX3-ANT2, EXT1, EXT2 passing	25	30	-	dB
RX3-ANT2 Isolation	ISL17	$P_{in}=10\text{dBm}$ RX3-ANT1, EXT1, EXT2 passing	23	25	-	dB
RX3-EXT1 Isolation	ISL18	$P_{in}=10\text{dBm}$ RX3-ANT1, ANT2, EXT2 passing	25	28	-	dB
RX3-EXT2 Isolation	ISL19	$P_{in}=10\text{dBm}$ RX3-ANT1, ANT2, EXT1 passing	25	30	-	dB
Input Power at 0.5dB Compression 2	$P_{-0.5(2)}$	RX3-ANT1, ANT2, EXT1, EXT2 passing	25	28	-	dBm
VSWR 4	VSWR4	RX3-ANT1, ANT2, EXT1, EXT2 passing	-	1.3	1.5	dBc
Switching Time 4	T_{D4}	CTL1~7	-	200	500	dBc

■ELECTRICAL CHARACTERISTICS 6 [1.5GHz TX,RX Mode]

General Conditions: $T_a=+25^{\circ}\text{C}$, $V_{DD}=3.3\text{V}$, $V_{SS}=0\text{V}$, $f_{in}(\text{TX})=940\sim 960\text{MHz}$, $f_{in}(\text{RX})=810\sim 830\text{MHz}$
 Tested on PCB circuit as shown below.

Insertion loss of each connectors, striplines, and capacitors are excluded.

TX1, TX2, RX1, RX2, RX3, ANT1, ANT2, EXT1, and EXT2: terminated (50Ω)

TER1~6: grounded by 5pF capacitor

Condition 1: RX1 Open

Condition 2: TX1 Open

PARAMETER	SYMBOL	CONDITONS	MIN	TYP	MAX	UNITS
TX1-ANT1 Insertion Loss	LOSS15	Pin=30dBm TX1-RX1-ANT1 passing, Condition 1	-	0.90	1.05	dB
	LOSS16	Pin=30dBm TX1-ANT1, RX1-ANT2 passing, Condition 1	-	0.40	0.55	dB
TX1-ANT2 Insertion Loss	LOSS17	Pin=30dBm TX1-ANT2, RX1-ANT1 passing, Condition 1	-	0.40	0.55	dB
	LOSS18	Pin=30dBm TX1-RX1-ANT2 passing, Condition 1	-	0.95	1.10	dB
TX1-EXT1 Insertion Loss	LOSS19	Pin=30dBm TX1-RX1-EXT1 passing, Condition 1	-	1.00	1.15	dB
	LOSS20	Pin=30dBm TX1-EXT1,RX1-EXT2 passing, Condition 1	-	0.40	0.55	dB
RX1-ANT1 Insertion Loss	LOSS21	Pin=10dBm TX1-RX1-ANT1 passing, Condition 2	-	1.05	1.20	dB
	LOSS22	Pin=10dBm TX1-ANT2, RX1-ANT1 passing, Condition 2	-	0.90	1.05	dB
RX1-ANT2 Insertion Loss	LOSS23	Pin=10dBm TX1-ANT1, RX1-ANT2 passing, Condition 2	-	0.95	1.10	dB
	LOSS24	Pin=10dBm TX1-RX1-ANT2 passing, Condition 2	-	1.10	1.25	dB
RX1-EXT1 Insertion Loss	LOSS25	Pin=10dBm TX1-RX1-EXT1 passing, Condition 2	-	1.10	1.25	dB
RX1-EXT2 Insertion Loss	LOSS26	Pin=10dBm TX1-EXT1, RX1-EXT2 passing, Condition 2	-	1.15	1.30	dB
TX1-RX1 Isolation	ISL20	Pin=30dBm TX1- ANT1, RX1-ANT2 passing	23	28	-	dB
	ISL21	Pin=30dBm TX1- EXT1, RX1-EXT2 passing	30	35	-	dB
	ISL22	Pin=30dBm TX1- ANT2, RX1-ANT1 passing	23	28	-	dB
TX1-RX2 Isolation	ISL23	Pin=30dBm TX1-RX1-ANT1 passing, Condition 1	25	29	-	dB
	ISL24	Pin=30dBm TX1-ANT1, RX1-ANT2 passing, Condition 1	45	50	-	dB
	ISL25	Pin=30dBm TX1-RX1-EXT1 passing, Condition 1	25	30	-	dB
	ISL26	Pin=30dBm TX1-EXT1, RX1-EXT2 passing, Condition 1	45	50	-	dB
	ISL27	Pin=30dBm TX1-ANT1, RX1-ANT1 passing, Condition 1	45	50	-	dB
	ISL28	Pin=30dBm TX1-RX1-ANT2 passing, Condition 1	25	30	-	dB

NJG1540JA3

www.DataSheet4U.com

TX1-ANT1 Isolation	ISL29	Pin=30dBm TX1-RX1-EXT1 passing, Condition 1	25	30	-	dB
	ISL30	Pin=30dBm TX1-EXT1,RX1-EXT2 passing, Condition 1	25	30	-	dB
	ISL31	Pin=30dBm TX1-ANT2,RX1-ANT1 passing, Condition 1	17	20	-	dB
	ISL32	Pin=30dBm TX1-RX1-ANT2 passing, Condition 1	17	20	-	dB
TX1-ANT2 Isolation	ISL33	Pin=30dBm TX1-RX1-ANT1 passing, Condition 1	17	20	-	dB
	ISL34	Pin=30dBm TX1-ANT1,RX1-ANT2 passing, Condition 1	17	20	-	dB
	ISL35	Pin=30dBm TX1-RX1-EXT1 passing, Condition 1	28	33	-	dB
	ISL36	Pin=30dBm TX1-EXT1,RX1-EXT2 passing, Condition 1	28	33	-	dB
TX1-EXT1 Isolation	ISL37	Pin=30dBm TX-RX1-ANT1 passing, Condition 1	23	25	-	dB
	ISL38	Pin=30dBm TX1-ANT1,RX1-ANT2 passing, Condition 1	23	27	-	dB
	ISL39	Pin=30dBm TX1-ANT1,RX1-ANT2 passing, Condition 1	25	30	-	dB
	ISL40	Pin=30dBm TX1-RX1-ANT2 passing, Condition 1	23	28	-	dB
TX1-EXT2 Isolation	ISL41	Pin=30dBm TX1-RX1-ANT1 passing, Condition 1	28	33	-	dB
	ISL42	Pin=30dBm TX1-ANT1,RX1-ANT2 passing, Condition 1	50	55	-	dB
	ISL43	Pin=30dBm TX1-RX1-EXT1 passing, Condition 1	28	33	-	dB
	ISL44	Pin=30dBm TX1-EXT1,RX1-EXT2 passing, Condition 1	25	30	-	dB
	ISL45	Pin=30dBm TX1-ANT2,RX1-ANT1 passing, Condition 1	45	50	-	dB
	ISL46	Pin=30dBm TX1-RX1-ANT2 passing, Condition 1	25	32	-	dB
RX1-ANT1 Isolation	ISL47	Pin=10dBm TX1-ANT1,RX1-ANT2 passing, Condition 2	17	21	-	dB
	ISL48	Pin=10dBm TX1-RX1-EXT1 passing, Condition 2	23	27	-	dB
	ISL49	Pin=10dBm TX1-EXT1,RX1-EXT2 passing, Condition 2	30	37	-	dB
	ISL50	Pin=10dBm TX1-RX1-ANT2 passing, Condition 2	17	20	-	dB

RX1-ANT2 Isolation	ISL51	Pin=10dBm TX1-RX1-ANT1 passing, Condition 2	17	20	-	dB
	ISL52	Pin=10dBm TX1-RX1-EXT1 passing, Condition 2	25	30	-	dB
	ISL53	Pin=10dBm TX1-EXT1,RX1-EXT2 passing, Condition 2	30	36	-	dB
	ISL54	Pin=10dBm TX1-ANT2,RX1-ANT1 passing, Condition 2	17	21	-	dB
RX1-EXT1 Isolation	ISL55	Pin=10dBm TX1-RX1-ANT1 passing, Condition 2	23	26	-	dB
	ISL56	Pin=10dBm TX1-ANT1,RX1-ANT2 passing, Condition 2	30	35	-	dB
	ISL57	Pin=10dBm TX1-EXT1,RX1-EXT2 passing, Condition 2	25	30	-	dB
	ISL58	Pin=10dBm TX1-ANT2,RX1-ANT1 passing, Condition 2	23	28	-	dB
	ISL59	Pin=10dBm TX1-RX1-ANT2 passing, Condition 2	28	33	-	dB
RX1-EXT2 Isolation	ISL60	Pin=10dBm TX1-RX1-ANT1 passing, Condition 2	25	30	-	dB
	ISL61	Pin=10dBm TX1-ANT1,RX1-ANT2 passing, Condition 2	25	30	-	dB
	ISL62	Pin=10dBm TX1-RX1-EXT1 passing, Condition 2	25	30	-	dB
	ISL63	Pin=10dBm TX1-ANT2,RX1-ANT1 passing, Condition 2	25	30	-	dB
	ISL64	Pin=10dBm TX1-RX1-ANT2 passing, Condition 2	25	30	-	dB
Adjacent Channel Leakage Power 9	ACP9	PDC Standard, $\pm 50\text{kHz}$ offset $P_{in}=30\text{dBm}$, Load: $VSWR=1.5$ Input Signal ACP=-64dBc @ 30dBm	-	-65	-63	dBc
Adjacent Channel Leakage Power 10	ACP10	PDC Standard, $\pm 50\text{kHz}$ offset, $P_{in}=30\text{dBm}$, Load: $VSWR \leq 3.0$ Input Signal ACP=-64dBc @ 30dBm	-	-65	-60	dBc
Adjacent Channel Leakage Power 11	ACP11	PDC Standard, $\pm 50\text{kHz}$ offset, $V_{DD} \geq 3.0\text{V}$ $P_{in}=30\text{dBm}$, Load: $VSWR \leq 1.5$ Input Signal ACP=-64dBc @ 30dBm	-	-65	-60	dBc
Adjacent Channel Leakage Power 12	ACP12	PDC Standard, $\pm 100\text{kHz}$ offset $V_{DD} \geq 3.0\text{V}$ $P_{in}=30\text{dBm}$, Load: $VSWR \leq 1.5$ Input Signal ACP=-76dBc @ 30dBm	-	-73	-65	dBc
2nd Harmonics 3	2fo(3)	$P_{in}=30\text{dBm}$ $V_{DD} \geq 3.0\text{V}$, Load: $VSWR \leq 1.5$ Input Signal 2nd Harmonics=-70dBc	-	-68	-65	dBc
3rd Harmonics 3	3fo(3)	$P_{in}=30\text{dBm}$ $V_{DD} \geq 3.0\text{V}$, Load: $VSWR \leq 1.5$ Input Signal 3rd Harmonics=-100dBc	-	-60	-57	dBc

NJG1540JA3

www.DataSheet4U.com

■ TERMINAL INFORMATION

PIN No.	SYMBOL	DESCRIPTION
1	VDD	Positive voltage supply terminal. The positive voltage (+2.7~+5.0V) have to be supplied. Please connect a bypass capacitor with GND terminal for excellent RF performance.
2	TERM5	ANT2 termination port (1.5GHz band). Please connect this port and GND by appropriate capacitor to suppress the interference of ANT2 port signal to ANT1 port. The capacitor works as DC voltage (V_{DD}) blocking.
3	TERM4	ANT2 termination port (800MHz RX Mode). Please connect this port and GND by appropriate capacitor to suppress the interference of ANT2 port signal to ANT1 port. The capacitor works as DC voltage (V_{DD}) blocking.
4	TERM3	ANT2 termination port (800MHz TX Mode). Please connect this port and GND by appropriate capacitor to suppress the interference of ANT2 port signal to ANT1 port. The capacitor works as DC voltage (V_{DD}) blocking.
5	ANT2	RF transmitting/receiving port. An external capacitor is required to block DC voltage (V_{DD}).
7	EXT1	RF transmitting/receiving port. An external capacitor is required to block DC voltage (V_{DD}).
10	TX1	RF transmitting port (800MHz band). An external capacitor is required to block DC voltage (V_{DD}).
12	TX2	RF transmitting port (1.5GHz band). An external capacitor is required to block DC voltage (V_{DD}).
13	TERM6	ANT1 termination port (800MHz TX Mode). Please connect this port and GND by appropriate capacitor to suppress the interference of ANT1 port signal to ANT2 port. The capacitor works as DC voltage (V_{DD}) blocking.
14	ANT1	RF transmitting/receiving port. An external capacitor is required to block DC voltage (V_{DD}).
15	TERM2	ANT1 termination port (1.5GHz band). Please connect this port and GND by appropriate capacitor to suppress the interference of ANT1 port signal to ANT2 port. The capacitor works as DC voltage (V_{DD}) blocking.
16	TERM1	ANT1 termination port (800MHz TX Mode). Please connect this port and GND by appropriate capacitor to suppress the interference of ANT1 port signal to ANT2 port. The capacitor works as DC voltage (V_{DD}) blocking.
17	RX3	RF transmitting port (1.5GHz band). An external capacitor is required to block DC voltage (V_{DD}).
19	RX2	RF transmitting port (800MHz A band). An external capacitor is required to block DC voltage (V_{DD}).
21	RX3	RF transmitting port (800MHz D/C band). An external capacitor is required to block DC voltage (V_{DD}).
23	EXT2	RF receiving port. An external capacitor of is required to block DC voltage (V_{DD}).
25	VSS	Negative voltage supply terminal. Please supply negative voltage of -3.5~-2.0V on transmitting state. On receiving state, this terminal is internally disconnected, so the voltage of this terminal (negative, short, or open) does not affect to receiving signal quality. The bypass capacitor should be connected between this terminal and GND for excellent RF performance.
26	CTL7	High-impedance C-MOS input terminal. This terminal is set to High-Level (+2V~ V_{DD}) or Low-Level (+0.6V~0V). If the voltage level of this terminal is unstable, please connect a resistor (100k Ω) with GND terminal or V_{DD} terminal.
27	CTL6	High-impedance C-MOS input terminal. This terminal is set to High-Level (+2V~ V_{DD}) or Low-Level (+0.6V~0V). If the voltage level of this terminal is unstable, please connect a resistor (100k Ω) with GND terminal or V_{DD} terminal.
28	CT5	High-impedance C-MOS input terminal. This terminal is set to High-Level (+2V~ V_{DD}) or Low-Level (+0.6V~0V). If the voltage level of this terminal is unstable, please connect a resistor (100k Ω) with GND terminal or V_{DD} terminal.
29	CTL4	High-impedance C-MOS input terminal. This terminal is set to High-Level (+2V~ V_{DD}) or Low-Level (+0.6V~0V). If the voltage level of this terminal is unstable, please connect a resistor (100k Ω) with GND terminal or V_{DD} terminal.
30	CTL3	High-impedance C-MOS input terminal. This terminal is set to High-Level (+2V~ V_{DD}) or Low-Level (+0.6V~0V). If the voltage level of this terminal is unstable, please connect a resistor (100k Ω) with GND terminal or V_{DD} terminal.
31	CTL2	High-impedance C-MOS input terminal. This terminal is set to High-Level (+2V~ V_{DD}) or Low-Level (+0.6V~0V). If the voltage level of this terminal is unstable, please connect a resistor (100k Ω) with GND terminal or V_{DD} terminal.
32	CTL1	High-impedance C-MOS input terminal. This terminal is set to High-Level (+2V~ V_{DD}) or Low-Level (+0.6V~0V). If the voltage level of this terminal is unstable, please connect a resistor (100k Ω) with GND terminal or V_{DD} terminal.
6,8,9,11 18,20,22,24	GND	Ground terminal. Please connect this terminal with ground plane as close as possible for excellent RF performance.

APPLICATION CIRCUIT

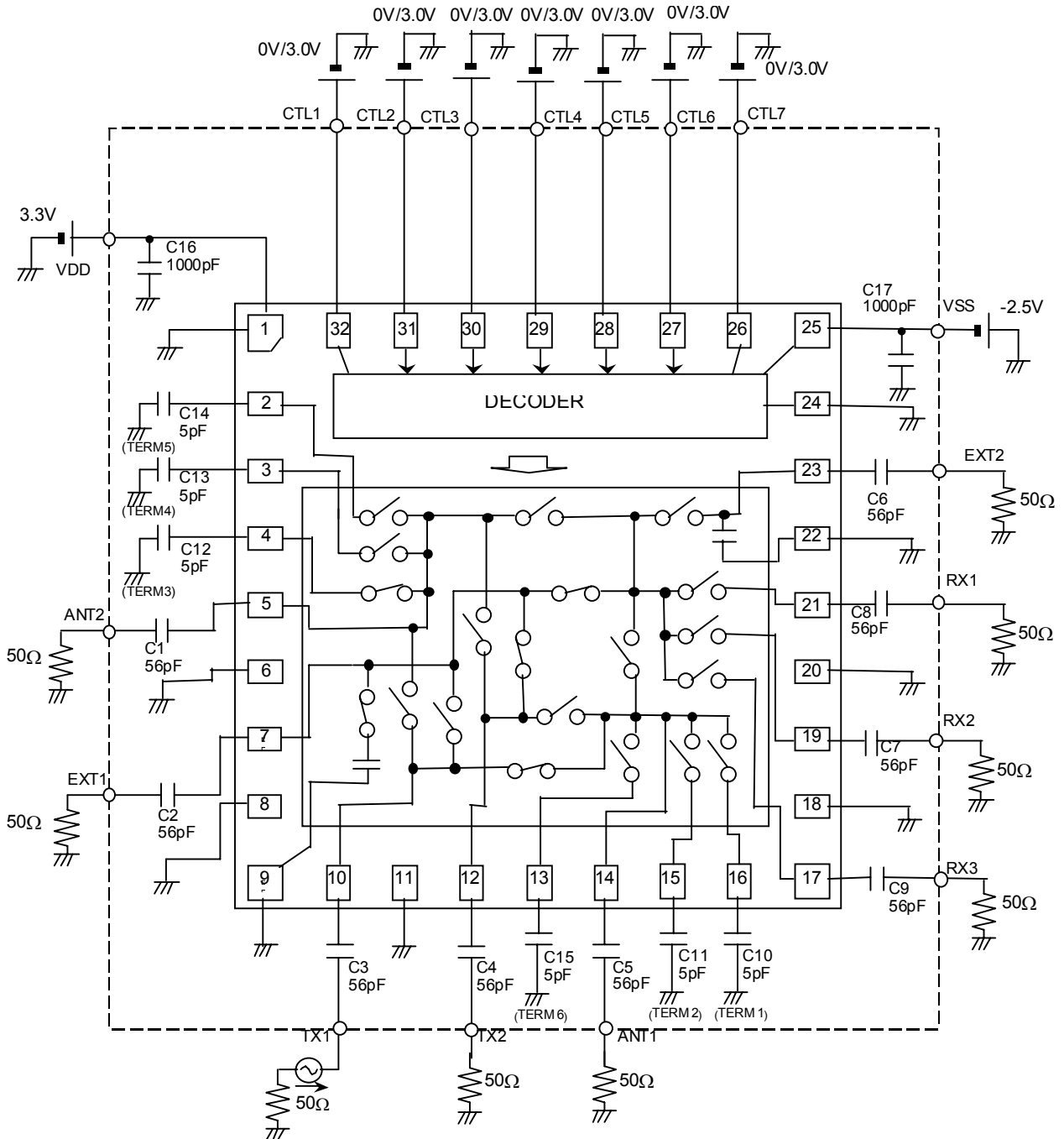

NJG1540JA3

www.DataSheet4U.com

TRUTH TABLE

"H"=V_{CTL} (H), "L"=V_{CTL} (L), "X"=H or L

No.	ROUTE	CONTOROL INPUT							CONTOROL OUTPUT																																
		CTL1	CTL2	CTL3	CTL4	CTL5	CTL6	CTL7	SW1	SW2	SW3	SW4	SW5	SW6	SW7	SW8	SW9	SW10	SW11	SW12	SW13	SW14	SW15	SW16	SW17	SW18	SW19	SW20	SW21												
1	TX1-ANT1	H	X	H	X	L	L	L	OFF	ON	OFF	OFF	OFF	OFF	ON	ON	OFF	ON	OFF	OFF	OFF	OFF	OFF	OFF	ON	OFF	OFF	OFF	OFF	ON	OFF	OFF	OFF	OFF	ON	OFF	OFF	OFF	OFF	ON	OFF
2	TX1-EXT1	H	X	L	X	L	X	L	OFF	OFF	ON	OFF	OFF	OFF	OFF	ON	OFF	ON	OFF	OFF	OFF	OFF	OFF	ON	OFF	OFF	OFF	ON	ON	OFF	OFF	OFF	OFF	OFF	ON	OFF	OFF	ON	ON	OFF	OFF
3	RX1-ANT1	L	L	H	L	L	X	X	ON	OFF	OFF	ON	OFF	OFF	ON	ON	OFF	OFF	OFF	OFF	OFF	ON	OFF	OFF	OFF	OFF	ON	OFF	OFF	OFF	OFF	OFF	OFF	ON	OFF	OFF	OFF	ON	OFF	OFF	
4	RX1-ANT2	L	H	H	L	L	X	X	OFF	OFF	OFF	ON	ON	ON	ON	ON	OFF	OFF	OFF	OFF	OFF	OFF	ON	OFF	OFF	OFF	ON	ON	OFF	OFF	OFF	OFF	OFF	OFF	ON	OFF	OFF	ON	OFF	OFF	
5	RX1-EXT1	L	L	L	L	L	X	X	OFF	ON	OFF	ON	OFF	ON	OFF	ON	OFF	ON	OFF	ON	OFF	ON	OFF	ON	OFF	ON	OFF	ON	OFF	ON	OFF	ON	OFF	ON	OFF	ON	OFF	ON	OFF	ON	
6	RX1-EXT2	L	H	L	L	L	X	X	OFF	OFF	ON	ON	OFF	ON	ON	OFF	OFF	OFF	OFF	OFF	OFF	ON	OFF	OFF	OFF	OFF	ON	OFF	OFF	OFF	OFF	OFF	OFF	OFF	OFF	OFF	OFF	OFF	OFF		
7	RX2-ANT1	L	L	H	H	L	X	X	ON	OFF	OFF	OFF	OFF	OFF	ON	ON	OFF	OFF	OFF	OFF	OFF	ON	OFF	OFF	ON	OFF	OFF	ON	OFF	OFF	OFF	OFF	OFF	ON	OFF	OFF	OFF	ON	OFF	OFF	
8	RX2-ANT2	L	H	H	H	L	X	X	OFF	OFF	OFF	OFF	ON	ON	ON	ON	OFF	OFF	OFF	ON	OFF	OFF	ON	OFF	OFF	ON	ON	OFF	OFF	OFF	OFF	OFF	OFF	ON	OFF	OFF	ON	OFF	OFF		
9	RX2-EXT1	L	L	L	H	L	X	X	OFF	ON	OFF	OFF	OFF	ON	OFF	ON	OFF	ON	OFF	ON	OFF	ON	OFF	ON	OFF	ON	OFF	ON	OFF	ON	OFF	ON	OFF	ON	OFF	ON	OFF	ON	OFF	ON	
10	RX2-EXT2	L	H	L	H	L	X	X	OFF	OFF	ON	OFF	OFF	ON	ON	OFF	OFF	OFF	ON	OFF	OFF	ON	OFF	OFF	ON	OFF	OFF	OFF	OFF	OFF	OFF	OFF	OFF	OFF	OFF	OFF	OFF	OFF	OFF		
11	TX2-ANT1	H	X	H	X	H	L	L	OFF	OFF	ON	OFF	OFF	OFF	ON	ON	OFF	ON	OFF	OFF	OFF	ON	OFF	ON	OFF	ON	OFF	ON	OFF	ON	OFF	ON	OFF	ON	OFF	ON	OFF	ON	OFF		
12	TX2-EXT1	H	X	L	X	H	X	L	OFF	ON	ON	OFF	OFF	OFF	OFF	ON	ON	OFF	ON	OFF	OFF	OFF	ON	OFF	ON	OFF	ON	OFF	ON	OFF	ON	OFF	ON	OFF	ON	OFF	ON	OFF	ON		
13	RX3-ANT1	L	L	H	X	H	X	X	ON	OFF	OFF	OFF	OFF	OFF	ON	ON	OFF	OFF	OFF	ON	ON	OFF	OFF	ON	OFF	OFF	ON	OFF	OFF	ON	OFF	OFF	ON	OFF	OFF	ON	OFF	OFF	ON		
14	RX3-ANT2	L	H	H	X	H	X	X	OFF	OFF	OFF	OFF	ON	OFF	ON	ON	OFF	ON	OFF	ON	OFF	OFF	ON	OFF	OFF	ON	OFF	OFF	ON	OFF	OFF	ON	OFF	OFF	ON	OFF	OFF	ON	OFF		
15	RX3-EXT1	L	L	L	X	H	X	X	OFF	ON	OFF	OFF	OFF	OFF	ON	ON	OFF	ON	OFF	ON	OFF	ON	OFF	ON	OFF	ON	OFF	ON	OFF	ON	OFF	ON	OFF	ON	OFF	ON	OFF	ON	OFF	ON	
16	RX3-EXT2	L	H	L	X	H	X	X	OFF	OFF	ON	OFF	OFF	OFF	ON	ON	OFF	ON	OFF	ON	OFF	ON	OFF	ON	OFF	ON	OFF	ON	OFF	ON	OFF	ON	OFF	ON	OFF	ON	OFF	ON	OFF	ON	
17	TX1-ANT2	H	X	H	X	L	H	L	OFF	OFF	ON	OFF	OFF	OFF	ON	ON	OFF	ON	OFF	OFF	OFF	OFF	OFF	OFF	OFF	ON	OFF	OFF	OFF	OFF	OFF	OFF	ON	OFF	ON	OFF	OFF	ON	OFF		
18	TX2-ANT2	H	X	H	X	H	H	L	OFF	OFF	ON	OFF	OFF	OFF	ON	ON	OFF	ON	OFF	OFF	OFF	OFF	OFF	OFF	OFF	ON	OFF	OFF	ON	OFF	ON	OFF	ON	OFF	ON	OFF	ON	OFF	ON		
19	TX1-RX1-ANT1	H	L	H	L	L	L	H	ON	ON	OFF	ON	OFF	OFF	ON	ON	OFF	ON	OFF	OFF	OFF	OFF	OFF	OFF	OFF	ON	OFF	OFF	OFF	OFF	OFF	OFF	ON	OFF	OFF	OFF	OFF	OFF	OFF		
20	TX1-ANT1, RX1-ANT2	H	H	H	L	L	L	H	OFF	ON	OFF	ON	ON	OFF	ON	ON	OFF	ON	OFF	OFF	OFF	OFF	OFF	OFF	OFF	ON	OFF	OFF	OFF	OFF	OFF	OFF	ON	OFF	OFF	OFF	OFF	OFF	OFF		
21	TX1-RX1-EXT1	H	L	L	L	L	L	H	OFF	OFF	OFF	ON	OFF	ON	OFF	ON	ON	OFF	ON	OFF	OFF	OFF	OFF	OFF	ON	OFF	ON	OFF	OFF	OFF	OFF	OFF	ON	OFF	OFF	OFF	ON	ON	OFF		
22	TX1-EXT1, RX1-EXT2	H	H	L	L	L	L	H	OFF	OFF	ON	ON	OFF	OFF	OFF	ON	ON	OFF	ON	OFF	OFF	OFF	OFF	OFF	ON	OFF	ON	OFF	OFF	OFF	OFF	OFF	ON	OFF	OFF	ON	ON	OFF	OFF		
23	TX1-ANT2, RX1-ANT1	H	L	H	L	L	H	H	ON	OFF	OFF	ON	OFF	OFF	ON	ON	OFF	ON	OFF	OFF	OFF	OFF	OFF	OFF	ON	OFF	OFF	OFF	OFF	OFF	OFF	ON	OFF	OFF	OFF	OFF	OFF	ON	OFF		
24	TX1-RX1-ANT2	H	H	H	L	L	H	H	OFF	OFF	OFF	ON	ON	OFF	ON	ON	OFF	ON	OFF	OFF	OFF	OFF	OFF	OFF	ON	OFF	OFF	OFF	OFF	OFF	OFF	ON	OFF	OFF	OFF	OFF	OFF	ON	OFF		

PIN CONFIGURATION (TOP VIEW)

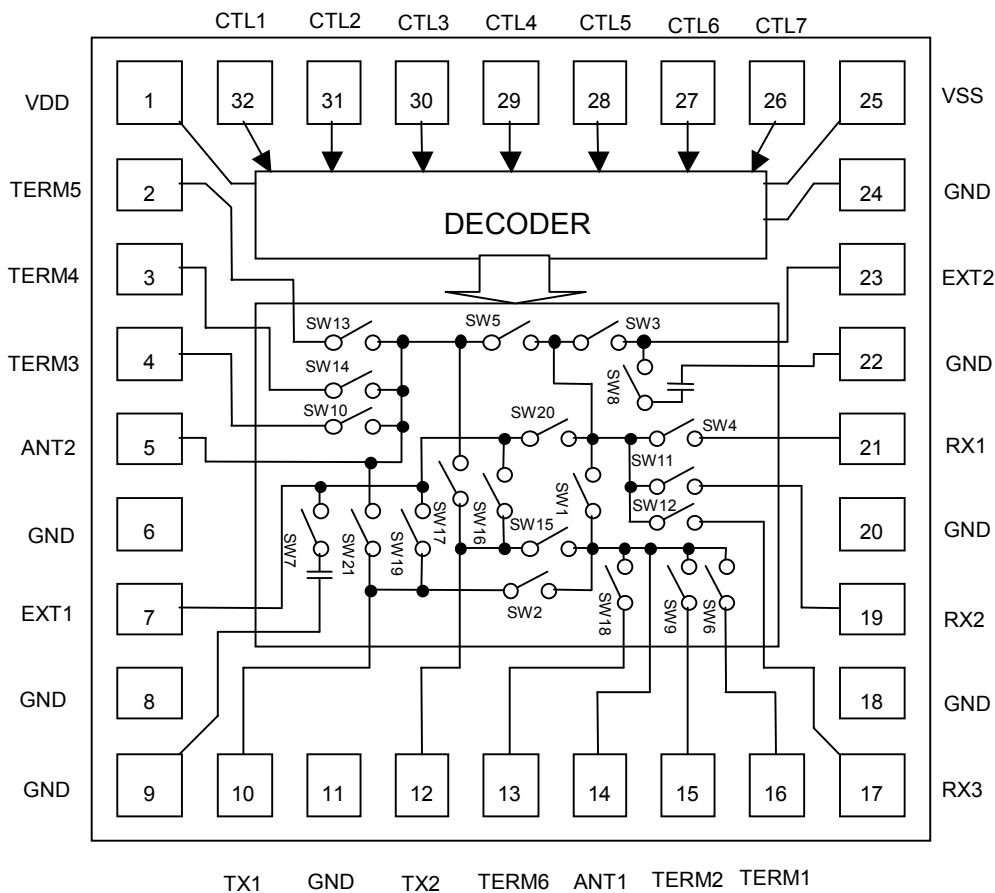

RECOMMENDED PCB DESIGN

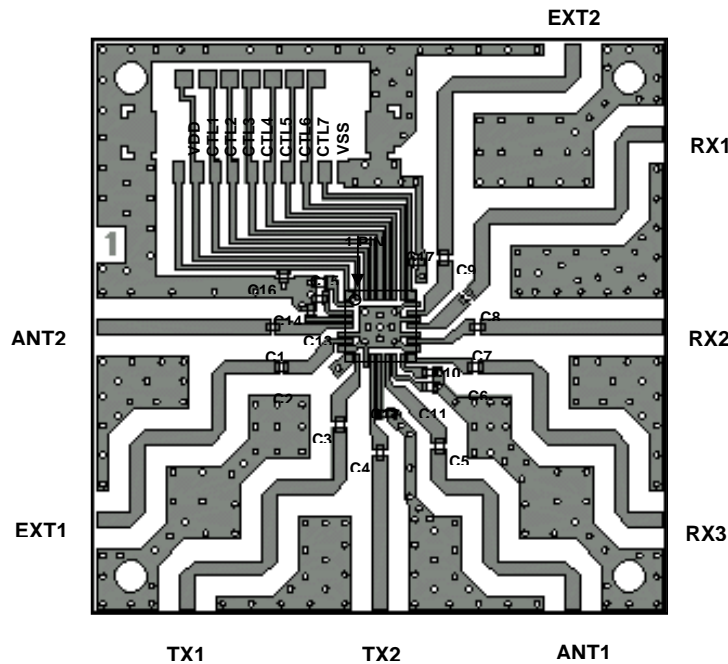

PCB: FR-4, t=0.5mm
Strip line width=1.0mm

Board total Loss (Capacitor, Connector, and PCB)

Pass route	Loss(dB)	Frequency
TX1-ANT1	0.33	800MHz Band
TX1-ANT2	0.28	
TX1-EXT1	0.33	
RX1-ANT1	0.31	
RX1-ANT2	0.28	
RX1-EXT1	0.31	
RX1-EXT2	0.31	
RX2-ANT1	0.28	
RX2-ANT2	0.23	
RX2-EXT1	0.28	1.5GHz Band
RX2-EXT2	0.28	
TX2-ANT1	0.36	
TX2-ANT2	0.29	
TX2-EXT1	0.36	
RX3-ANT1	0.46	
RX3-ANT2	0.37	
RX3-EXT1	0.46	
RX3-EXT2	0.46	

Parts List

Parts number	Value	Comment
C1 – C9	56pF	MURATA(GRM36)
C10 – C15	5pF	
C16, C17	1000pF	

PRECAUTIONS

- [1] The bypass capacitors should be connected to the VDD, VSS terminals as close as possible respectively.
- [2] For good RF performance, the ground terminals should be directly connected to the ground patterns and through-holes as close as possible by using relatively wide pattern.

NJG1540JA3

www.DataSheet4U.com