

DPDT SWITCH GaAs MMIC

■ GENERAL DESCRIPTION

NJG1648HB6 is a GaAs DPDT switch IC that features low loss, low current consumption and low control voltage.

This IC includes logic decoder, and can be operated by 1bit control signal at low control voltage from +1.3V.

A small & thin USB8-B6 package is adopted.

■ PACKAGE OUTLINE

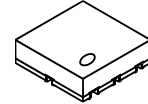

NJG1648HB6

■ FEATURES

- 1bit low control voltage operation +1.3V min.
- Low voltage operation +2.5V min
- Low current consumption 20uA typ.
- Low control current consumption 5uA typ.
- Low insertion loss 0.20dB typ. @f=500MHz, P_{IN}=+18dBm
- 0.25dB typ. @f=1GHz, P_{IN}=+18dBm
- 0.40dB typ. @f=2GHz, P_{IN}=+18dBm
- Small & thin package USB8-B6 (Package size: 1.5 x 1.5 x 0.55 mm typ.)

■ PIN CONFIGURATION

USB8-B6 Type
(Top View)

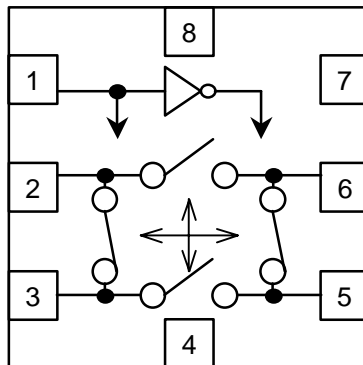

Pin connection

1. CTL
2. P1
3. P2
4. GND
5. P3
6. P4
7. VDD
8. GND

■ TRUTH TABLE

“H”=V_{CTL(H)}, “L”=V_{CTL(L)}

CTL	PATH
H	P1-P4, P2-P3
L	P1-P2, P3-P4

NOTE: Please note that any information on this catalog will be subject to change.

NJG1648HB6

■ ABSOLUTE MAXIMUM RATINGS

$T_a=+25^{\circ}\text{C}$, $Z_s=Z_l=50\text{ohm}$

PARAMETER	SYMBOL	CONDITIONS	CONDITIONS	UNITS
Supply Voltage	V_{DD}	VDD terminal	5.0	V
Control Voltage	V_{CTL}	CTL terminal	5.0	V
RF Input Power	P_{in}	$V_{DD}=2.7\text{V}$, $V_{CTL}=0\text{V}/1.8\text{V}$, P1, P2, P3, P4 Terminal	27	dBm
Power Dissipation	P_D	At on PCB board	160	mW
Operating Temp.	T_{opr}		-40~+85	$^{\circ}\text{C}$
Storage Temp.	T_{stg}		-55~+150	$^{\circ}\text{C}$

■ ELECTRICAL CHARACTERISTICS

General conditions: $V_{DD}=2.7\text{V}$, $V_{CTL(L)}=0\text{V}$, $V_{CTL(H)}=1.8\text{V}$, $T_a=+25^{\circ}\text{C}$ $Z_s=Z_l=50\Omega$, with test circuit

PARAMETERS	SYMBOL	CONDITIONS	MIN	TYP	MAX	UNITS
Supply Voltage	V_{DD}	VDD terminal	2.5	2.7	5.0	V
Operating Current	I_{DD}	$P_{in}=+18\text{dBm}$	-	20	35	μA
Control Voltage (LOW)	$V_{CTL(L)}$		-	-	0.4	V
Control Voltage (HIGH)	$V_{CTL(H)}$		1.3	1.8	V_{DD}	V
Control Current	I_{CTL}	CTL Terminal	-	5	10	μA
Insertion Loss 1	LOSS1	$f=500\text{MHz}$, $P_{IN}=+18\text{dBm}$	-	0.20	0.40	dB
Insertion Loss 2	LOSS2	$f=1\text{GHz}$, $P_{IN}=+18\text{dBm}$	-	0.25	0.50	dB
Insertion Loss 3	LOSS3	$f=2\text{GHz}$, $P_{IN}=+18\text{dBm}$	-	0.40	0.60	dB
Isolation 1	ISL1	$f=500\text{MHz}$, $P_{IN}=+18\text{dBm}$	24	26	-	dB
Isolation 2	ISL2	$f=1\text{GHz}$, $P_{IN}=+18\text{dBm}$	19	21	-	dB
Isolation 3	ISL3	$f=2\text{GHz}$, $P_{IN}=+18\text{dBm}$	13	15	-	dB
Pin at 0.2dB Compression Point	$P_{-0.2\text{dB}}$	$f=2\text{GHz}$	20	23	-	dBm
VSWR	VSWR	$f=2\text{GHz}$, ON State	-	1.2	1.4	
Switching time	T_{SW}	RF signal switching	-	2	5	μs

■ TERMINAL INFORMATION

No.	SYMBOL	DESCRIPTION
1	CTL	Control signal input terminal. This terminal is set to High-Level (+1.3V~VDD) or Low-Level (~+0.4V).
2	P1	RF port. This port is connected with P4 port by controlling 1pin-CTL(H) (+1.3~+VDD). This port is connected with P2 port by controlling 1pin- CTL(L) (~+0.4V) . A DC cut capacitor is required at this terminal to block DC voltage of inner circuit.
3	P2	RF port. This port is connected with P3 port by controlling 1pin- CTL(H) (+1.3~+VDD). This port is connected with P1 port by controlling 1pin- CTL(L) (~+0.4V). A DC cut capacitor is required at this terminal to block DC voltage of inner circuit.
4	GND	Ground terminal. Please connect this terminal with ground plane as close as possible for excellent RF performance.
5	P3	RF port. This port is connected with P2 port by controlling 1pin- CTL(H) (+1.3~+VDD). This port is connected with P4 port by controlling 1pin-V _{CTL(L)} (~+0.4V). A DC cut capacitor is required at this terminal to block DC voltage of inner circuit.
6	P4	RF port. This port is connected with P1 port by controlling 1pin- CTL(H) (+1.3~+VDD). This port is connected with P3 port by controlling 1pin- CTL(L) (~+0.4V). A DC cut capacitor is required at this terminal to block DC voltage of inner circuit.
7	VDD	Positive voltage supply terminal. The positive voltage (+2.5~+5.0V) have to be supplied. Please connect a bypass capacitor with GND terminal for excellent RF performance.
8	GND	Ground terminal. Please connect this terminal with ground plane as close as possible for excellent RF performance.

NJG1648HB6

ELECTRICAL CHARACTERISTICS

(f=0.1~3.0GHz, with application circuit, Losses of external circuit are excluded)

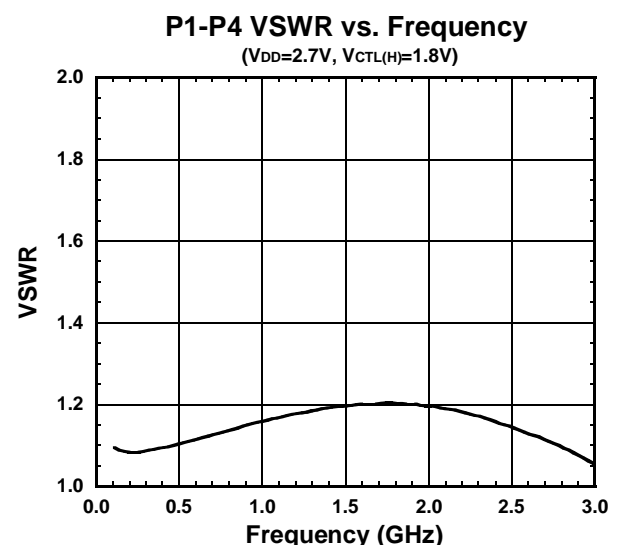
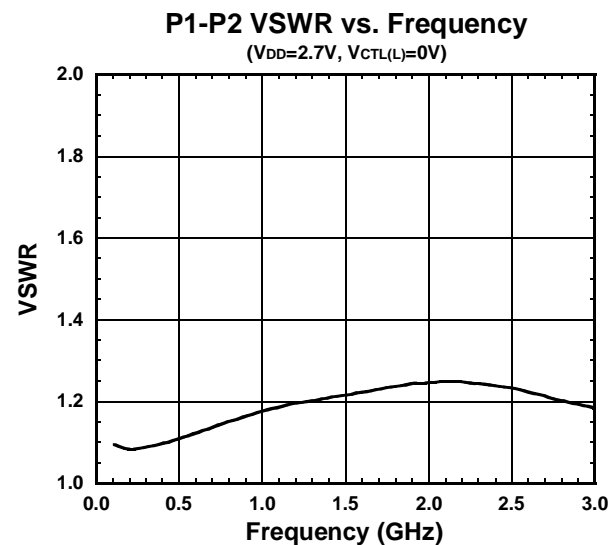
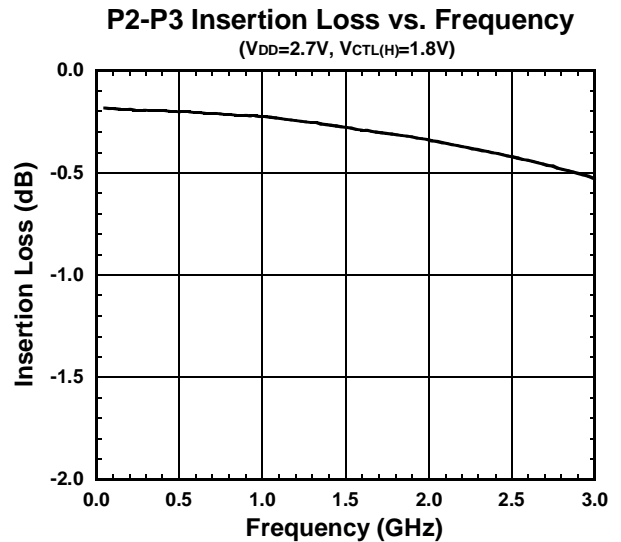
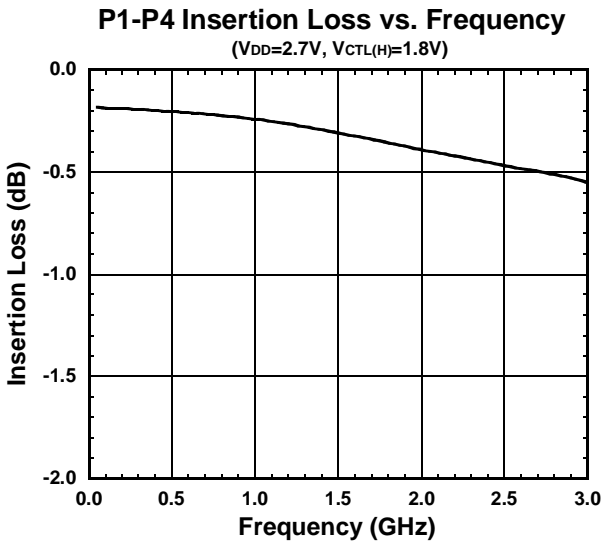
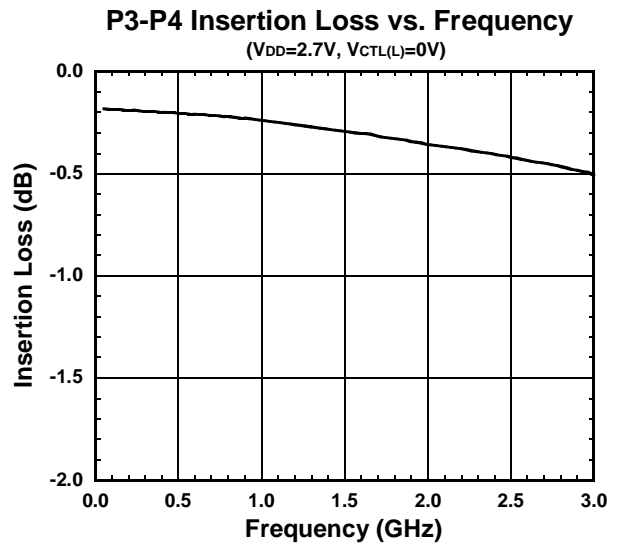
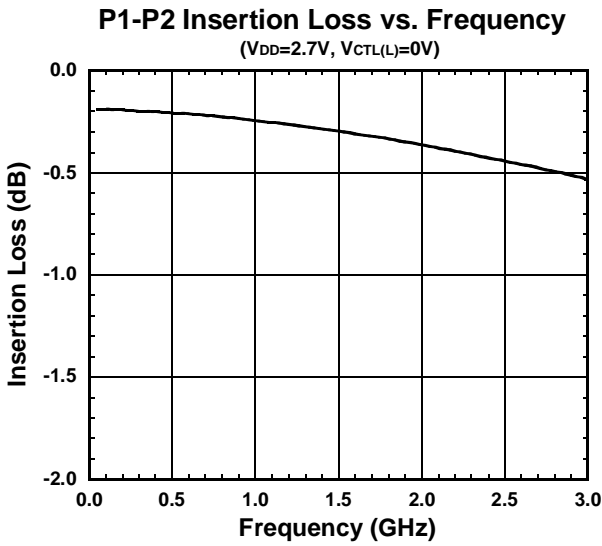

■ ELECTRICAL CHARACTERISTICS

(f=0.1~3.0GHz, with application circuit, Losses of external circuit are excluded)

P1-P2 Isolation vs. Frequency

(V_{DD}=2.7V, V_{CTL(H)}=1.8V)

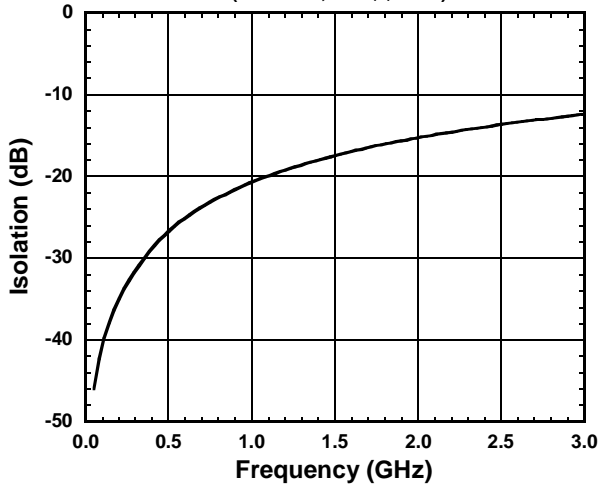

P3-P4 Isolation vs. Frequency

(V_{DD}=2.7V, V_{CTL(H)}=1.8V)

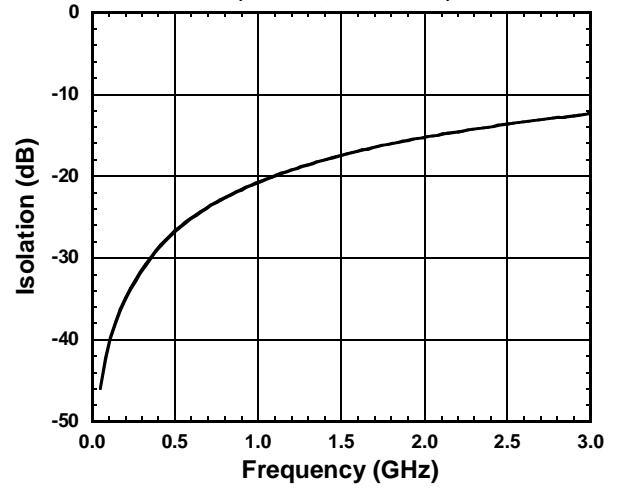

P1-P4 Isolation vs. Frequency

(V_{DD}=2.7V, V_{CTL(L)}=0V)

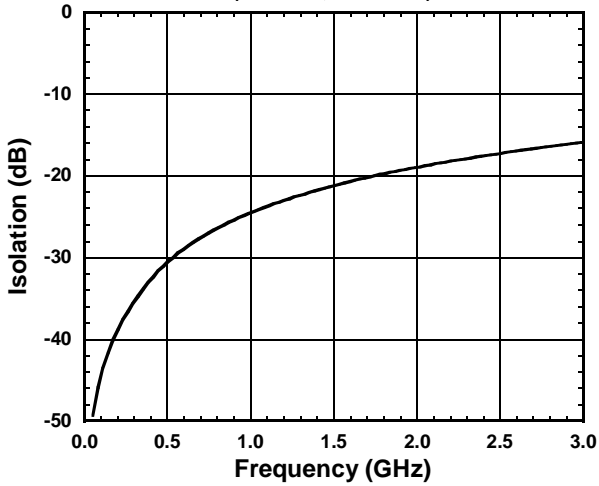

P2-P3 Isolation vs. Frequency

(V_{DD}=2.7V, V_{CTL(L)}=0V)

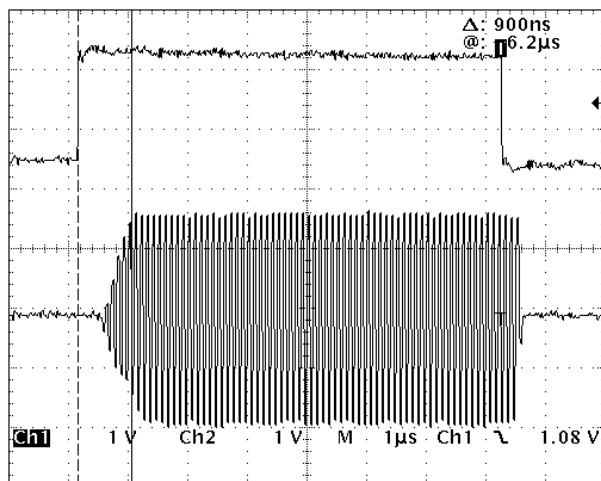
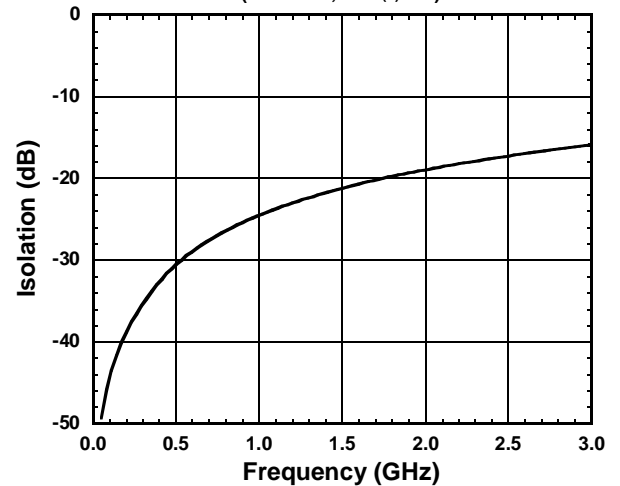

NJG1648HB6

ELECTRICAL CHARACTERISTICS

(With application circuit, Losses of external circuit are excluded)

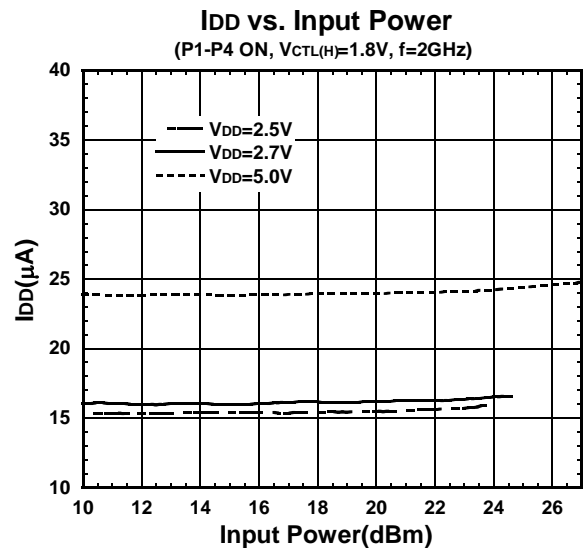
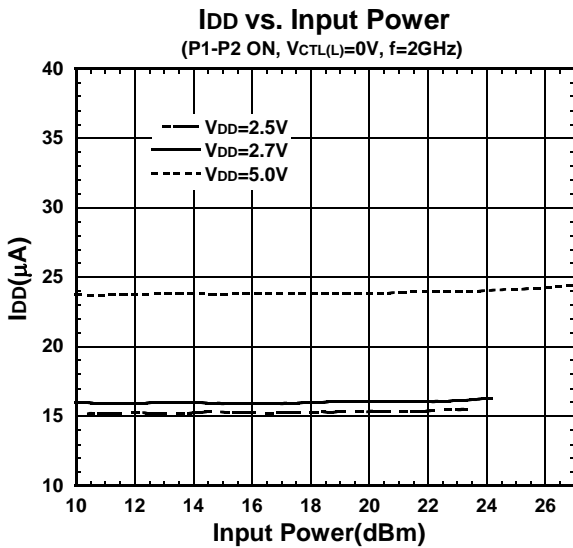
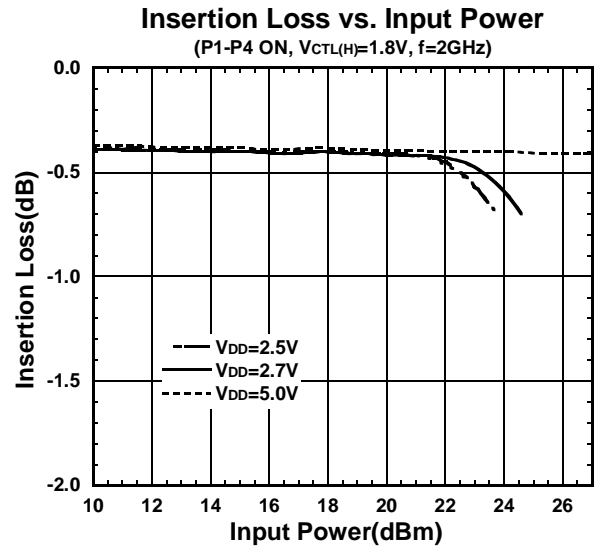
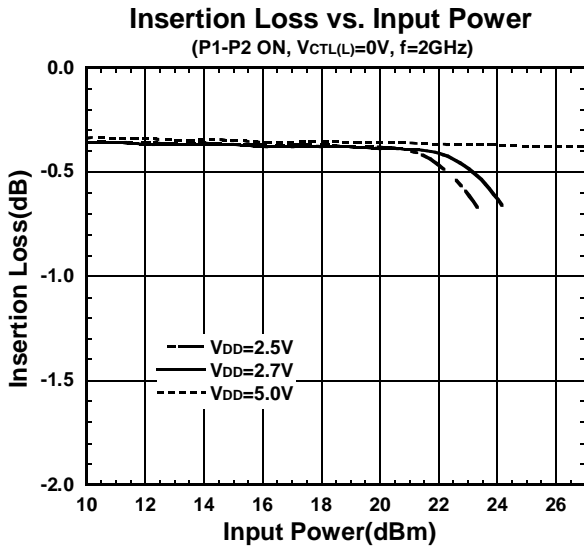

ELECTRICAL CHARACTERISTICS

(With application circuit, Losses of external circuit are excluded)

Insertion Loss vs. Ambient Temperature
(P1-P2 ON, f=500MHz, Pin=18dBm)

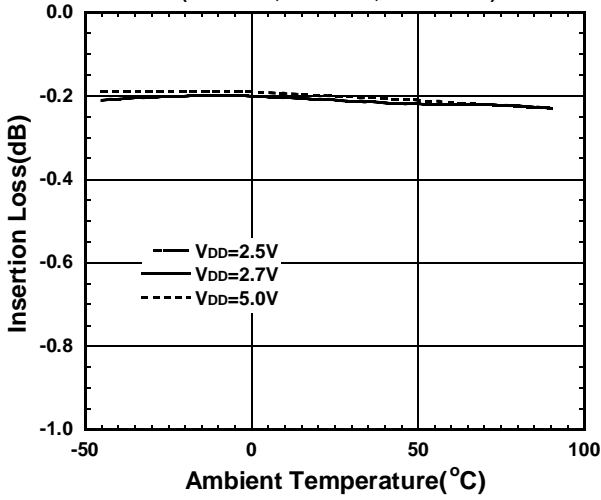

Isolation vs. Ambient Temperature
(P1-P2 ON, f=500MHz, Pin=18dBm)

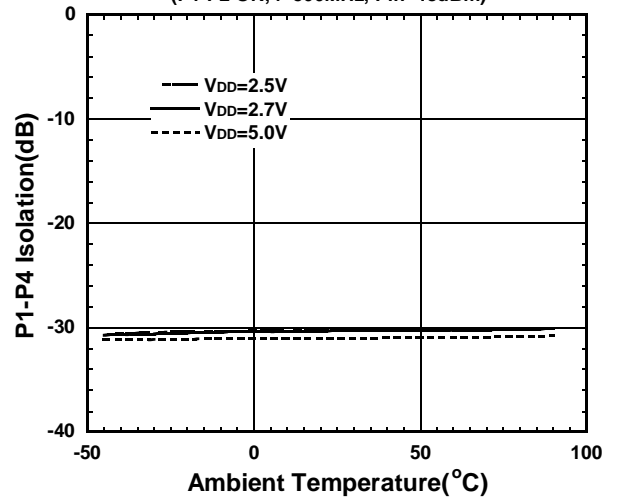

Insertion Loss vs. Ambient Temperature
(P1-P2 ON, f=1GHz, Pin=18dBm)

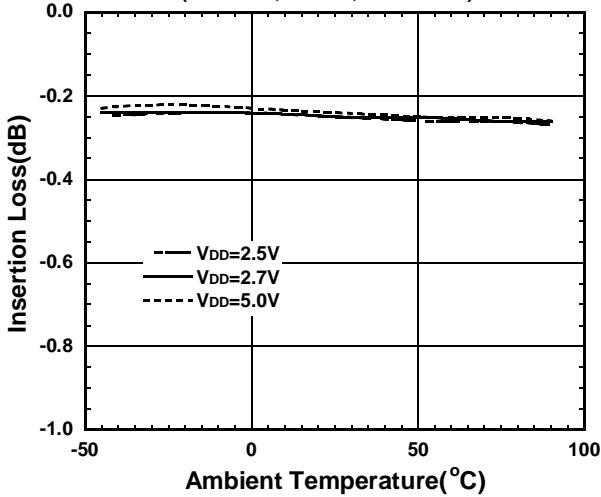

Isolation vs. Ambient Temperature
(P1-P2 ON, f=1GHz, Pin=18dBm)

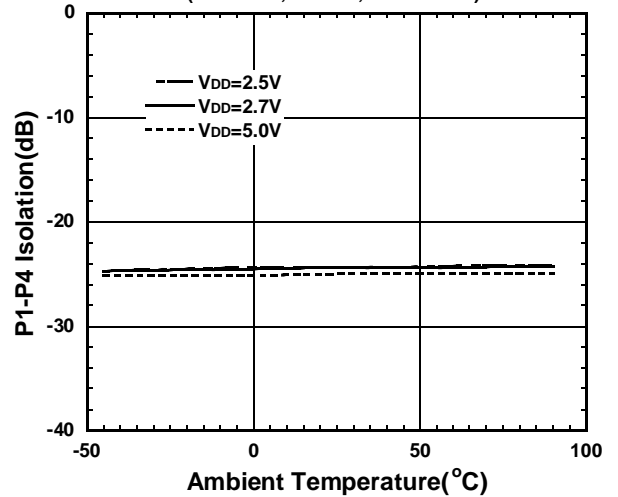

Insertion Loss vs. Ambient Temperature
(P1-P2 ON, f=2GHz, Pin=18dBm)

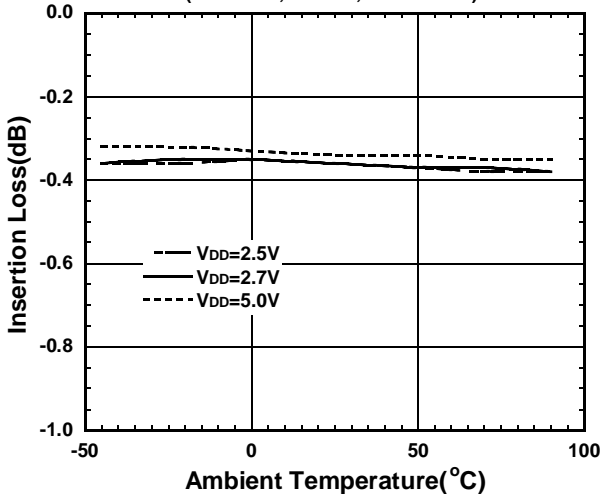

Isolation vs. Ambient Temperature
(P1-P2 ON, f=2GHz, Pin=18dBm)

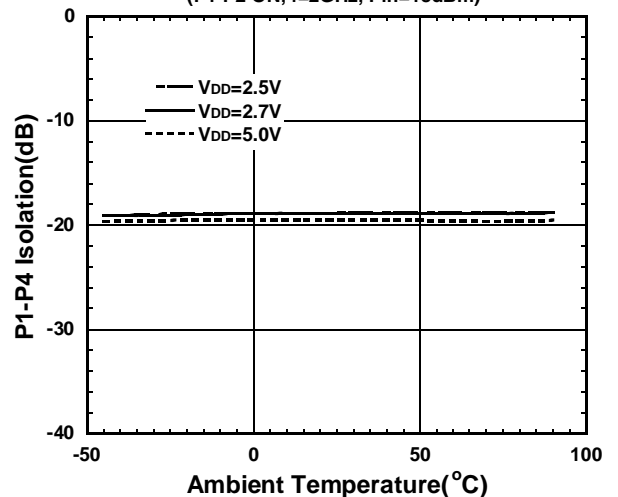

NJG1648HB6

ELECTRICAL CHARACTERISTICS

(With application circuit)

P-0.2dB vs. Ambient Temperature
(P1-P4 ON, $V_{CTL(H)}=1.8V$, $f=2GHz$)

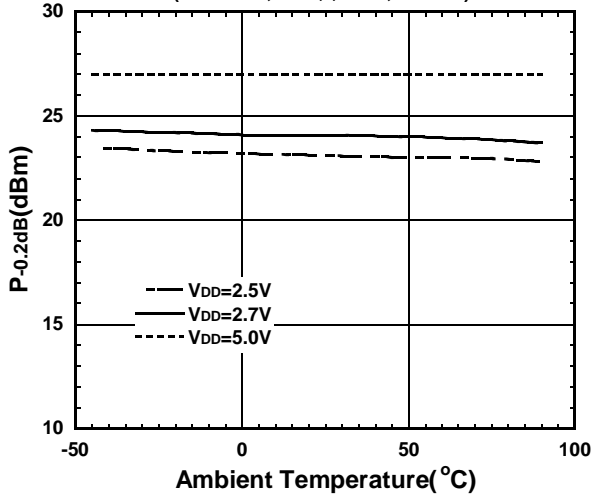

Switching Speed vs. Ambient Temperature
($V_{CTL(L)}=0V$, $V_{CTL(H)}=1.8V$)

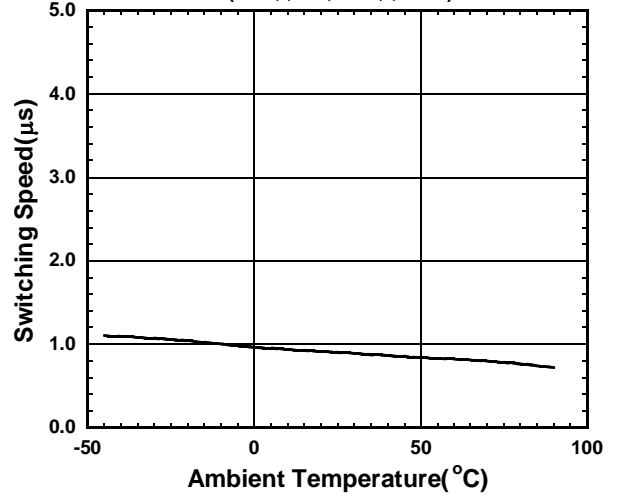

IDD vs. Ambient Temperature
($V_{CTL(H)}=1.8V$, $f=2GHz$, $P_{in}=18dBm$)

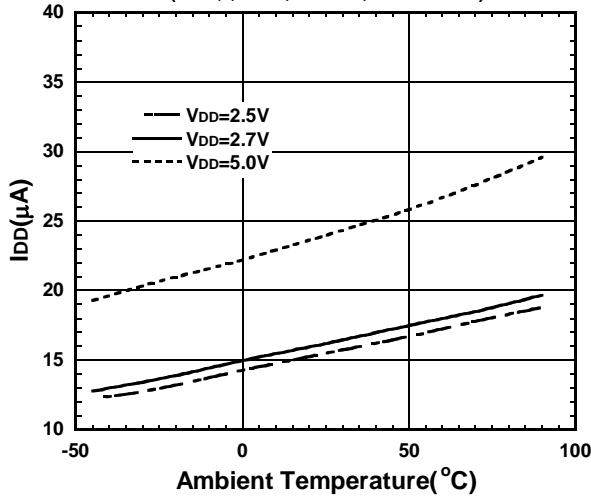

ICTL vs. Ambient Temperature
(P1-P4 ON, P2-P3 ON)

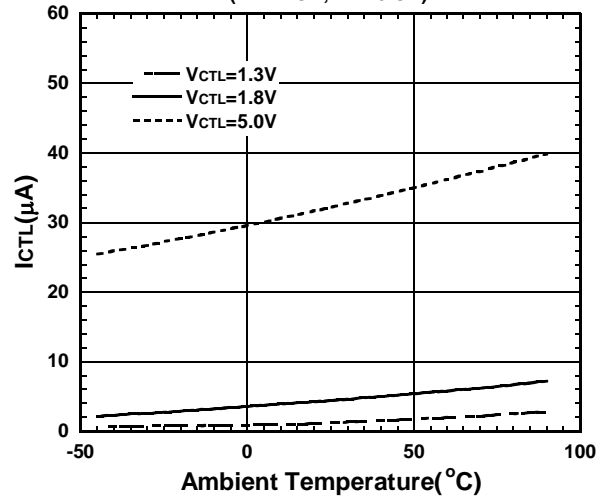

APPLICATION CIRCUIT

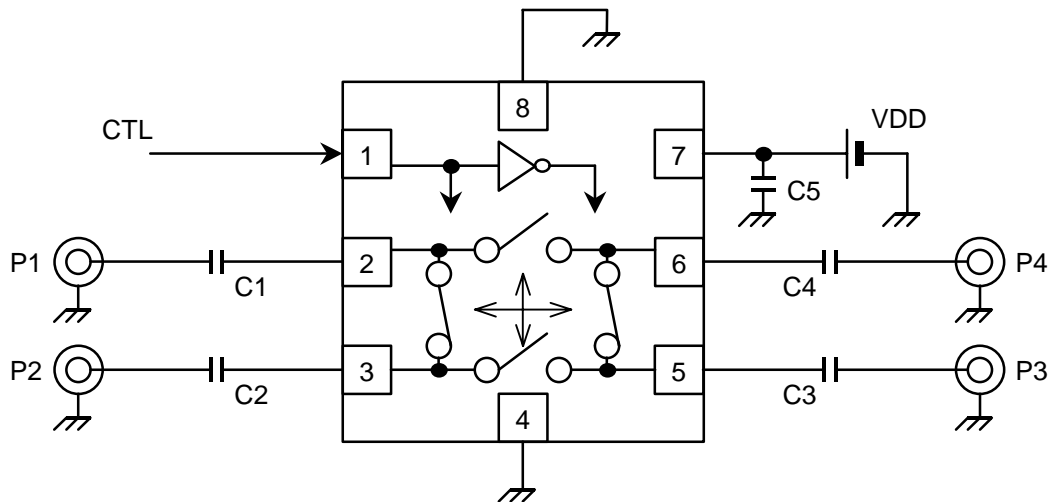

PARTS LIST

Parts	Constant	Notes
C1~C5	1000pF	MURATA (GRM15)

TEST PCB LAYOUT

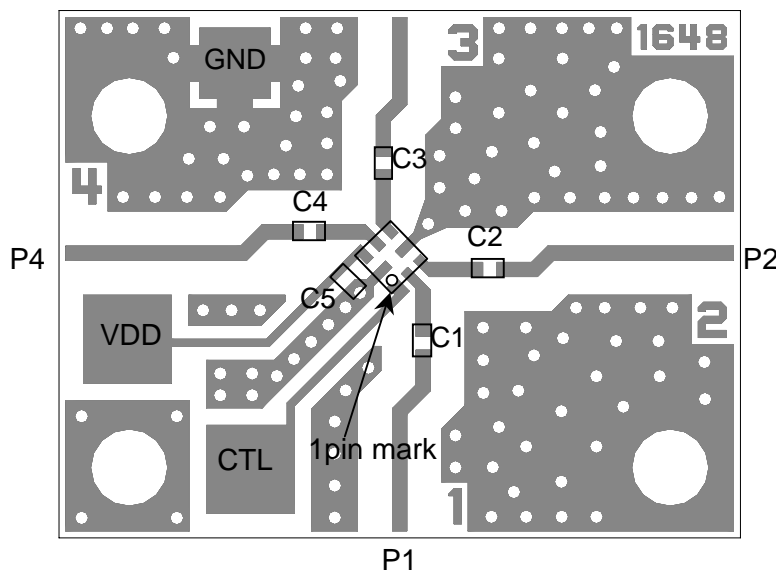

PCB SIZE=19.4x15.0mm
 PCB: FR-4, t=0.2mm
 CAPACITOR: size 1005
 Strip line Width==0.4mm

PRECAUTIONS

- [1] The DC blocking capacitors have to be placed at RF terminal of PC1, PC2, PC3, PC4.
- [2] To reduce stripline influence on RF characteristics, please locate bypass capacitors (C5) close to terminal.
- [3] To avoid degradation of isolation or high power characteristics, please layout ground pattern right under this IC.

NJG1648HB6

PACKAGE OUTLINE (USB8-B6)

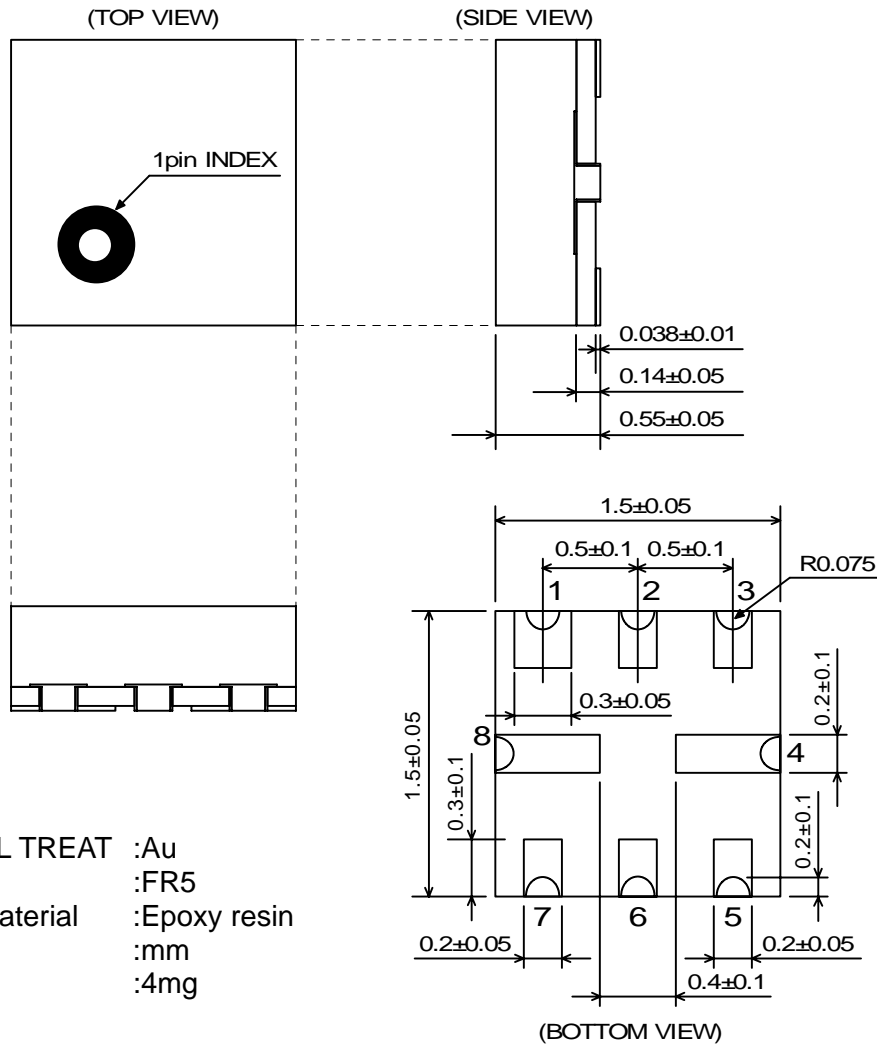

Cautions on using this product

This product contains Gallium-Arsenide (GaAs) which is a harmful material.

- Do NOT eat or put into mouth.
- Do NOT dispose in fire or break up this product.
- Do NOT chemically make gas or powder with this product.
- To waste this product, please obey the relating law of your country.

[CAUTION]

The specifications on this databook are only given for information, without any guarantee as regards either mistakes or omissions. The application circuits in this databook are described only to show representative usages of the product and not intended for the guarantee or permission of any right including the industrial rights.

This product may be damaged with electric static discharge (ESD) or spike voltage. Please handle with care to avoid these damages.