

SP9T ANTENNA SWITCH GaAs MMIC

■ GENERAL DESCRIPTION

The NJG1656LK4 is a GaAs SP9T antenna switch IC for GSM/TD-SCDMA multi-band handsets. The IC contains a MMIC switch die with on-chip logic circuits and a LTCC substrate with built-in three-LPFs on GSM/TD-SCDMA transmit paths for suppression of transmitter harmonics.

This switch IC features very low harmonics, low insertion loss, high Isolation and small package size.

This IC has ESD protection devices to achieve excellent ESD performances.

■ PACKAGE OUTLINE

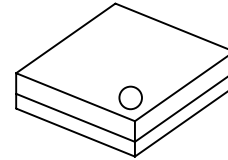

NJG1656LK4

■ FEATURES

- Built-in three LPFs Attenuation 32/32/30 dB typ. on GSM850/900 TX @2fo / 3fo / 4fo
Attenuation 32/40 dB typ. on GSM1800/1900 TX @2fo / 3fo
Attenuation 35/38 dB typ. on LCR TX @2fo / 3fo
- Low harmonics -85/-75dBc typ. on GSM850/900 TX @2fo / 3fo, Pin=+35dBm, V_{DD}=2.7V
-93/-82dBc typ. on GSM1800/1900 TX @2fo / 3fo, Pin=+32dBm, V_{DD}=2.7V
-88/-94dBc typ. on LCR TX @2fo / 3fo, Pin=+26dBm, V_{DD}=2.7V
- Low insertion loss 1.0dB typ. on GSM850/900 TX @f=915MHz, Pin=35dBm, V_{DD}=2.7V
0.9dB typ. on GSM1800/1900 TX @f=1910MHz, Pin=32dBm, V_{DD}=2.7V
1.0dB typ. on LCR TX @f=2025MHz, Pin=26dBm, V_{DD}=2.7V
- Small package size LCSP24-K4 (Package size: 3.8x3.8x0.9mm typ.)

■ PIN CONFIGURATION

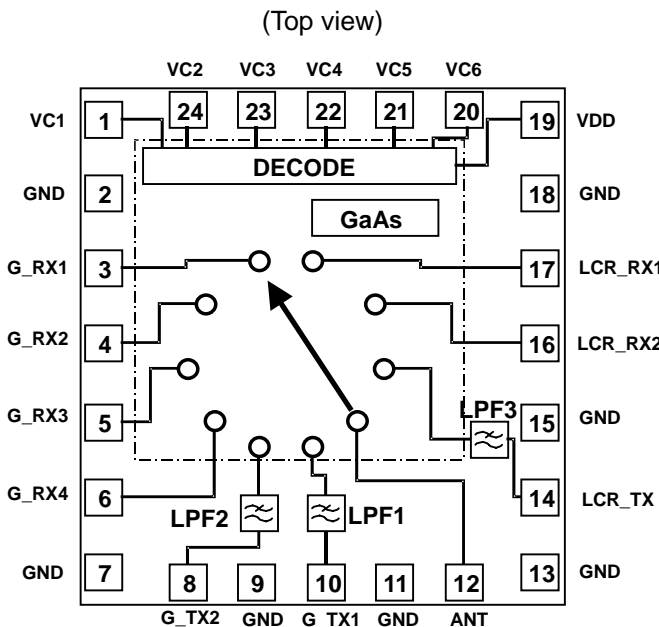

PIN CONNECTION

1. VC1
2. GND
3. G_RX1(GSM850 RX)
4. G_RX2(GSM900 RX)
5. G_RX3(GSM1800 RX)
6. G_RX4(GSM1900 RX)
7. GND
8. G_TX2(GSM1800/1900 TX)
9. GND
10. G_TX1(GSM850/900 TX)
11. GND
12. ANT
13. GND
14. LCR_TX(LCR 1.9G/2.0G TX)
15. GND
16. LCR_RX2(LCR 2.0G RX)
17. LCR_RX1(LCR 1.9G RX)
18. GND
19. VDD
20. VC6
21. VC5
22. VC4
23. VC3
24. VC2

Cautions on using this product

This product contains Gallium-Arsenide (GaAs) which is a harmful material.

- Do NOT eat or put into mouth.
- Do NOT dispose in fire or break up this product.
- Do NOT chemically make gas or powder with this product.
- To waste this product, please obey the relating law of your country.

[CAUTION]

The specifications on this databook are only given for information, without any guarantee as regards either mistakes or omissions. The application circuits in this databook are described only to show representative usages of the product and not intended for the guarantee or permission of any right including the industrial rights.

This product may be damaged with electric static discharge (ESD) or spike voltage. Please handle with care to avoid these damages.