

SP10T ANTENNA SWITCH GaAs MMIC

■ GENERAL DESCRIPTION

NJG1686MHH is a GaAs SP10T antenna switch MMIC suitable for LTE/3G/GSM multimode applications. This switch includes on-chip decoder circuits and low pass filters for GSM transmit port. This switch has six transmit/receive ports that provide more efficient band selection for multimode cellular application.

NJG1686MHH offers low insertion loss, high isolation, low harmonics and high linearity. The integrated ESD protection circuits in the switch IC bring excellent ESD performances. In addition, no DC blocking capacitors are required for the RF ports unless DC is biased externally. The small and thin package is adopted.

■ PACKAGE OUTLINE

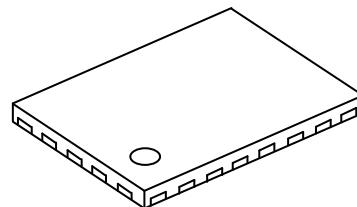

NJG1686MHH

■ APPLICATIONS

Multi-mode LTE, UMTS, CDMA and GSM applications

Mobile phone, Tablet PC, Data card, Modem, Router and others mobile device applications

■ FEATURES

- Low voltage operation $V_{DD}=+2.5V$ min.
- Low voltage logic control $V_{CTL(H)}=+1.8V$ typ.
- Low insertion loss
 - 0.65dB typ. @ 452 to 960MHz, TRX1 to 3,5,6-ANT
 - 0.30dB typ. @ 452 to 960MHz, TRX4-ANT
 - 0.75dB typ. @ 1710 to 2170MHz, TRX1 to 3,5,6-ANT
 - 0.45dB typ. @ 1710 to 2170MHz, TRX4-ANT
 - 1.10dB typ. @ 2300 to 2690MHz, TRX1 to 3,5,6-ANT
 - 0.45dB typ. @ 2300 to 2690MHz, TRX4-ANT
 - 1.05dB typ. @ GSM850/900, TX1-ANT
 - 1.20dB typ. @ GSM1800/1900, TX2-ANT
- High isolation
 - 38dB typ. @GSM850/900, TX1-TRX1 to 3,5,6
 - 34dB typ. @GSM1800/1900, TX2-TRX 1 to 3,5,6
 - 25dB typ. @f=452 to 2690MHz, TRX1-TRX3, TRX4-TRX6
 - 36dB typ. @f=1805 to 1990MHz, ANT-RX1,2,
 - 33dB typ. @f=452 to 2690MHz, opposed TRX ports
- High linearity
 - 2nd harmonics=-80dBm typ. @f=786.5MHz
 - IIP2=+95.5dBm min. @CDMA2000(AWS, PCS)
 - IIP2=+102dBm min. @UMTS
- No DC blocking capacitor unless DC is biased externally
- Small package size EQFN26-HH (Package size: 2.6 x 3.4 x 0.7 mm typ.)
- RoHS compliant and Pb free, Halogen Free, MSL1

NOTE: The information in this document is subject to change without notice.

NJG1686MHH

PIN CONFIGURATION

(TOP VIEW)

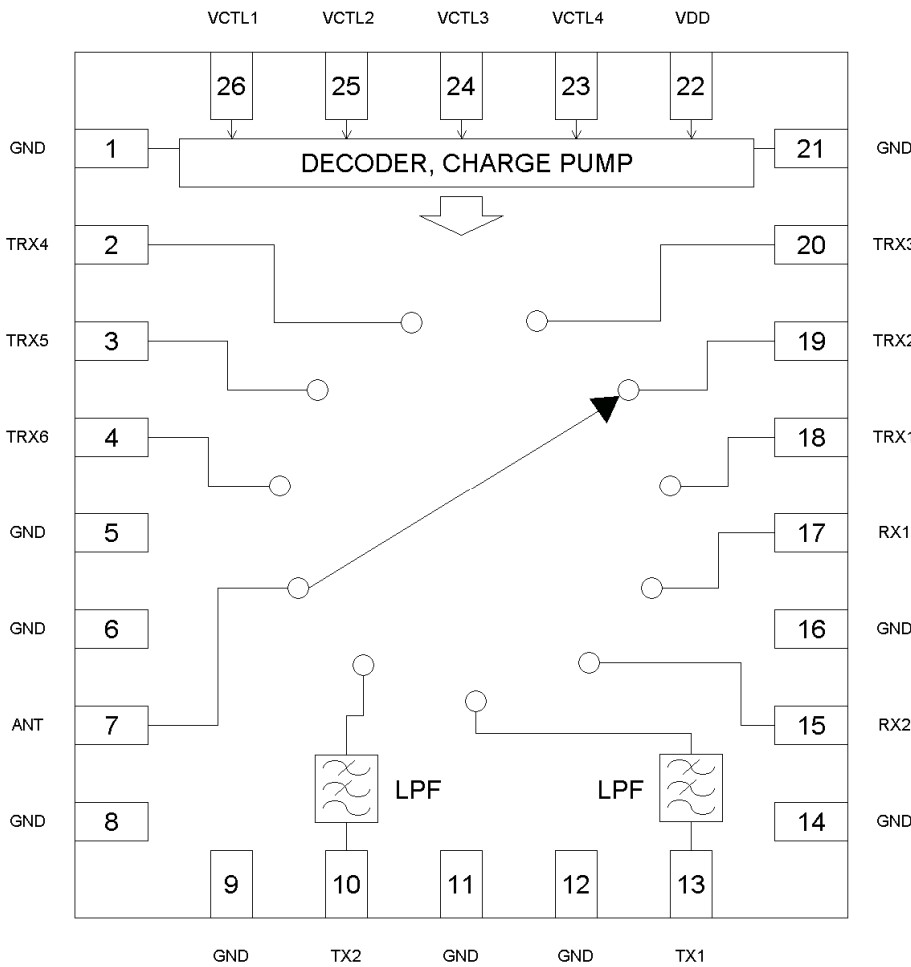

1. GND
2. TRX4
3. TRX5
4. TRX6
5. GND
6. GND
7. ANT
8. GND
9. GND
10. TX2
11. GND
12. GND
13. TX1
14. GND
15. RX2
16. GND
17. RX1
18. TRX1
19. TRX2
20. TRX3
21. GND
22. VDD
23. VCTL4
24. VCTL3
25. VCTL2
26. VCTL1

TRUTH TABLE

"H"= $V_{CTL(H)}$, "L"= $V_{CTL(L)}$

On Path	VCTL1	VCTL2	VCTL3	VCTL4
TX1-ANT	H	H	L	L
TX2-ANT	H	L	L	L
ANT-RX1	L	H	H	L
ANT-RX2	L	H	L	L
ANT-TRX1	L	L	H	L
ANT-TRX2	H	L	H	L
ANT-TRX3	H	H	H	L
ANT-TRX4	H	L	H	H
ANT-TRX5	H	H	H	H
ANT-TRX6	H	L	L	H

■ ABSOLUTE MAXIMUM RATINGS

($T_a=+25^{\circ}\text{C}$, $Z_s=Z_l=50\Omega$)

PARAMETER	SYMBOL	CONDITIONS	Duty cycle	RATINGS	UNITS
RF Input Power	Pin	GSM LB TX1 port	4:8	36	dBm
		GSM HB TX2 port	4:8	34	dBm
		TRX ports	CW	32	dBm
		RX ports	CW	28	dBm
Supply Voltage	V_{DD}	VDD terminal		5.0	V
Control Voltage	V_{CTL}	VCTL terminal		5.0	V
Power dissipation	P_D	Four-layer FR4 PCB with through-hole (101.5mmx114.5mm), $T_j=150^{\circ}\text{C}$		2200	mW
Operating Temperature	T_{opr}			-40 to +90	$^{\circ}\text{C}$
Storage Temperature	T_{stg}			-65 to +150	$^{\circ}\text{C}$

■ ELECTRICAL CHARACTERISTICS 1 (DC)

(General conditions: $T_a=+25^{\circ}\text{C}$, $Z_s=Z_l=50\Omega$, $V_{DD}=2.7\text{V}$, $V_{CTL(L)}=0\text{V}$, $V_{CTL(H)}=1.8\text{V}$, with application circuit)

PARAMETER	SYMBOL	CONDITIONS	MIN	TYP	MAX	UNITS
Supply Voltage	V_{DD}		2.5	2.7	5.0	V
Operating Current	I_{DD}		-	0.40	0.65	mA
Control Current	I_{CTL}	$V_{CTL(H)}=1.8\text{V}/1\text{Port}$	-	4	10	μA
Control Voltage	$V_{CTL(H)}$		1.35	1.8	5.0	V
	$V_{CTL(L)}$		0	-	0.45	V

NJG1686MHH

■ ELECTRICAL CHARACTERISTICS 2 (RF)

(General conditions: $T_a=+25^{\circ}\text{C}$, $Z_s=Z_L=50\Omega$, $V_{DD}=2.7\text{V}$, $V_{CTL(L)}=0\text{V}$, $V_{CTL(H)}=1.8\text{V}$, with application circuit)

PARAMETER	SYMBOL	CONDITIONS	MIN	TYP	MAX	UNITS
Insertion Loss 1 (1) TRX1	LOSS1(1)TRX1	TRX1 - ANT, 452 to 960MHz, Pin=26dBm	-	0.65	0.8	dB
Insertion Loss 1 (1) TRX2	LOSS1(1)TRX2	TRX2 - ANT, 452 to 960MHz, Pin=26dBm	-	0.65	0.8	dB
Insertion Loss 1 (1) TRX3	LOSS1(1)TRX3	TRX3 - ANT, 452 to 960MHz, Pin=26dBm	-	0.65	0.8	dB
Insertion Loss 1 (1) TRX4	LOSS1(1)TRX4	TRX4 - ANT, 452 to 960MHz, Pin=26dBm	-	0.3	0.45	dB
Insertion Loss 1 (1) TRX5	LOSS1(1)TRX5	TRX5 - ANT, 452 to 960MHz, Pin=26dBm	-	0.65	0.8	dB
Insertion Loss 1 (1) TRX6	LOSS1(1)TRX6	TRX6 - ANT, 452 to 960MHz, Pin=26dBm	-	0.65	0.8	dB
Insertion Loss 1 (2) TRX1	LOSS1(2)TRX1	TRX1 - ANT, 1710 to 2170MHz, Pin=26dBm	-	0.75	0.95	dB
Insertion Loss 1 (2) TRX2	LOSS1(2)TRX2	TRX2 - ANT, 1710 to 2170MHz, Pin=26dBm	-	0.9	1.1	dB
Insertion Loss 1 (2) TRX3	LOSS1(2)TRX3	TRX3 - ANT, 1710 to 2170MHz, Pin=26dBm	-	0.85	1.05	dB
Insertion Loss 1 (2) TRX4	LOSS1(2)TRX4	TRX4 - ANT, 1710 to 2170MHz, Pin=26dBm	-	0.45	0.65	dB
Insertion Loss 1 (2) TRX5	LOSS1(2)TRX5	TRX5 - ANT, 1710 to 2170MHz, Pin=26dBm	-	0.85	1.05	dB
Insertion Loss 1 (2) TRX6	LOSS1(2)TRX6	TRX6 - ANT, 1710 to 2170MHz, Pin=26dBm	-	0.75	0.95	dB
Insertion Loss 1 (3) TRX1	LOSS1(3)TRX1	TRX1 - ANT, 2300 to 2690MHz, Pin=26dBm	-	1.1	1.4	dB
Insertion Loss 1 (3) TRX2	LOSS1(3)TRX2	TRX2 - ANT, 2300 to 2690MHz, Pin=26dBm	-	1.25	1.55	dB
Insertion Loss 1 (3) TRX3	LOSS1(3)TRX3	TRX3 - ANT, 2300 to 2690MHz, Pin=26dBm	-	1.15	1.45	dB
Insertion Loss 1 (3) TRX4	LOSS1(3)TRX4	TRX4 - ANT, 2300 to 2690MHz, Pin=26dBm	-	0.45	0.75	dB
Insertion Loss 1 (3) TRX5	LOSS1(3)TRX5	TRX5 - ANT, 2300 to 2690MHz, Pin=26dBm	-	1.1	1.4	dB
Insertion Loss 1 (3) TRX6	LOSS1(3)TRX6	TRX6 - ANT, 2300 to 2690MHz, Pin=26dBm	-	1.1	1.4	dB
Insertion Loss 2	LOSS2	TRX4 - ANT, 704 to 787MHz (Band13, Band17), Pin=26dBm	-	0.25	0.4	dB
Insertion Loss 3	LOSS3	TX1 - ANT, 824 to 915MHz, Pin=35dBm	-	1.05	1.3	dB
Insertion Loss 4	LOSS4	TX2 - ANT, 1710 to 1910MHz, Pin=32dBm	-	1.2	1.4	dB
Insertion Loss 5(1)	LOSS5(1)	RX1,2 - ANT, 869 to 960MHz, Pin=10dBm	-	0.9	1.1	dB
Insertion Loss 5(2)	LOSS5(2)	RX1,2 - ANT, 1805 to 1990MHz, Pin=10dBm	-	1.0	1.2	dB

■ ELECTRICAL CHARACTERISTICS 3 (RF)

(General conditions: $T_a=+25^{\circ}\text{C}$, $Z_s=Z_l=50\Omega$, $V_{DD}=2.7\text{V}$, $V_{CTL(L)}=0\text{V}$, $V_{CTL(H)}=1.8\text{V}$, with application circuit)

PARAMETER	SYMBOL	CONDITIONS	MIN	TYP	MAX	UNITS
Isolation 1(1)	ISL1(1)	TX1-TRX1 to 3, TRX5,6, RX1 (TX1 ON) f=824 to 915MHz	35	38	-	dB
Isolation 1(2)	ISL1(2)	TX1-TRX4, RX2 (TX1 ON) f=824 to 915MHz	33	35	-	dB
Isolation 2(1)	ISL2(1)	TX2-TRX1 to 3, TRX5,6, RX1,2 (TX2 ON) f=1710 to 1910MHz	32	35	-	dB
Isolation 2(2)	ISL2(2)	TX2-TRX4 (TX2 ON) f=1710 to 1910MHz	31	34	-	dB
Isolation 3	ISL3	TRX1 – TRX3, TRX4 – TRX6, 452 to 2690MHz	23	25	-	dB
Isolation 4	ISL4	TRX1 – TRX2, TRX2 – TRX3, TRX4 – TRX5, TRX5 – TRX6, 452 to 2690MHz	17	20	-	dB
Isolation 5	ISL5	ANT – RX1 (RX2 ON), ANT – RX2 (RX1 ON), 1805 to 1990MHz	33	36	-	dB
Isolation 6(1)	ISL6(1)	TRX1 to 3 – TRX4 to 6 (TRX1 to 3 ON), 452 to 2690MHz	25	27	-	dB
Isolation 6(2)	ISL6(2)	TRX1 to 3 – TRX4 to 6 (TRX4 to 6 ON), 452 to 2690MHz	31	33	-	dB
VSWR (1)	VSWR (1)	TX1 ON 824 to 915MHz	-	-	1.5	-
VSWR (2)	VSWR (2)	TX2 ON 1710 to 1910MHz	-	-	1.6	-
VSWR (3)	VSWR (3)	TRX1 to 6 452 to 2170MHz	-	-	1.6	-
VSWR (4)	VSWR (4)	TRX1 to 6 452 to 2690MHz	-	-	1.8	-
VSWR (5)	VSWR (5)	RX1 to 2 869 to 1990MHz	-	-	1.5	-
Switching Speed	TSW	50% $V_{CTL(H)}$ to 10/90% RF	-	3	5	μs

NJG1686MHH

■ ELECTRICAL CHARACTERISTICS 4 (RF)

(General conditions: $T_a=+25^{\circ}\text{C}$, $Z_s=Z_l=50\Omega$, $V_{DD}=2.7\text{V}$, $V_{CTL(L)}=0\text{V}$, $V_{CTL(H)}=1.8\text{V}$, with application circuit)

PARAMETER	SYMBOL	CONDITIONS	MIN	TYP	MAX	UNITS
Triple Beat Ratio	TBR	TRX1 to 6 ON, 650 to 900 MHz 1710 to 2155 MHz	-	80	-	dBc
2nd Harmonics 1	2fo(1)	TRX1 to 6 ON, 452 to 1980 MHz, Pin=26dBm	-	-	-62	dBc
2nd Harmonics 2	2fo(2)	TX1 ON, 824 to 915 MHz Pin=35dBm	-	-	-70	dBc
2nd Harmonics 3	2fo(3)	TX2 ON, 1710 to 1910 MHz Pin=32dBm	-	-	-67	dBc
2nd Harmonics 4	2fo(4)	TRX4 ON, 786.5MHz (Band13), Pin=25dBm	-	-80	-	dBm
3rd Harmonics 1	3fo(1)	TRX1 to 6 ON, 452 to 1980 MHz, Pin=26dBm	-	-	-62	dBc
3rd Harmonics 2	3fo(2)	TX1 ON, 824 to 915 MHz Pin=35dBm	-	-	-70	dBc
3rd Harmonics 3	3fo(3)	TX2 ON, 1710 to 1910 MHz Pin=32dBm	-	-	-67	dBc
GSM Tx Attenuation 1	ATT(1)	TX1 ON, 2fo, 3fo	25	-	-	dB
GSM Tx Attenuation 2	ATT(2)	TX1 ON, Past 3fo to 12.75 GHz	16	-	-	dB
GSM Tx Attenuation 3	ATT(3)	TX2 ON, 2fo, 3fo	25	-	-	dB
GSM Tx Attenuation 4	ATT(4)	TX2 ON, Past 6.84 to 12.75 GHz	14	-	-	dB

■ ELECTRICAL CHARACTERISTICS 5 (RF)

(General conditions: $T_a=+25^{\circ}\text{C}$, $Z_s=Z_l=50\Omega$, $V_{DD}=2.7\text{V}$, $V_{CTL(L)}=0\text{V}$, $V_{CTL(H)}=1.8\text{V}$, with application circuit)

PARAMETER	SYMBOL	CONDITIONS	MIN	TYP	MAX	UNITS
IIP3(1) – UMTS mode (2600)	IIP3(1)	*Table 1, TRX1 to 6 ON	+60	-	-	dBm
IIP3(2) – UMTS mode (IMT)	IIP3(2)	*Table 1, TRX1 to 6 ON	+60	-	-	dBm
IIP3(3) – UMTS mode (PCS)	IIP3(3)	*Table 1, TRX1 to 6 ON	+61	-	-	dBm
IIP3(4) – UMTS mode (DCS)	IIP3(4)	*Table 1, TRX1 to 6 ON	+61	-	-	dBm
IIP3(5) – UMTS mode (PDC)	IIP3(5)	*Table 1, TRX1 to 6 ON	+61	-	-	dBm
IIP3(6) – UMTS mode (900)	IIP3(6)	*Table 1, TRX1 to 6 ON	+61	-	-	dBm
IIP3(7) – UMTS mode (US cell)	IIP3(7)	*Table 1, TRX1 to 6 ON	+61	-	-	dBm
IIP2(1) – UMTS mode (2600)	IIP2(1)	*Table 1, TRX1 to 6 ON	+102	-	-	dBm
IIP2(2) – UMTS mode (IMT)	IIP2(2)	*Table 1, TRX1 to 6 ON	+102	-	-	dBm
IIP2(3) – UMTS mode (PCS)	IIP2(3)	*Table 1, TRX1 to 6 ON	+102	-	-	dBm
IIP2(4) – UMTS mode (DCS)	IIP2(4)	*Table 1, TRX1 to 6 ON	+102	-	-	dBm
IIP2(5) – UMTS mode (PDC)	IIP2(5)	*Table 1, TRX1 to 6 ON	+102	-	-	dBm
IIP2(6) – UMTS mode (900)	IIP2(6)	*Table 1, TRX1 to 6 ON	+102	-	-	dBm
IIP2(7) – UMTS mode (US cell)	IIP2(7)	*Table 1, TRX1 to 6 ON	+102	-	-	dBm
IIP2(8) – C2K mode (AWS)	IIP2(8)	*Table 2, TRX1 to 6 ON	+95.5	-	-	dBm
IIP2(9) – C2K mode (PCS)	IIP2(9)	*Table 2, TRX1 to 6 ON	+95.5	-	-	dBm
IIP2(10) – C2K mode (cell)	IIP2(10)	*Table 2, TRX1 to 6 ON	+111.5	-	-	dBm

Table 1 IIP2/IIP3 UMTS Mode

	Band	CW tone 1 (MHz)	CW tone 1 (dBm)	CW tone 2 (MHz)	CW tone 2 (dBm)	Min IIP 2 (dBm)
IIP2	2600	2535	20	120	-15	+102
	IMT	1950	20	190	-15	+102
	PCS	1880	20	80	-15	+102
	DCS	1745	20	95	-15	+102
	PDC	1440	20	48	-15	+102
	900	892	20	45	-15	+102
	US cell	835	20	45	-15	+102
IIP3	2600	2535	20	2415	-15	+60
	IMT	1950	20	1760	-15	+60
	PCS	1880	20	1800	-15	+61
	DCS	1745	20	1650	-15	+61
	PDC	1440	20	1392	-15	+61
	900	892	20	847	-15	+61
	US cell	835	20	790	-15	+61

Table 2 IIP2 C2k Mode

Band	Temp (°C)	In-band Freq (MHz)	CW tone 1 Freq (MHz)	CW tone Power (dBm)	CW tone 2 Freq (MHz)	CW tone 2 Power (dBm)	Min IIP 2 (dBm)
Cell	25	869.28	824.28	26	1693.56	-20	+111.5
	-30, 25, 85	881.61	836.61	26	1718.22	-20	+111.5
	25	893.31	848.31	26	1741.62	-20	+111.5
PCS	25	1930.05	1850.05	26	3780.1	-20	+95.5
	-30, 25, 85	1965	1885	26	3850	-20	+95.5
	25	1989.95	1909.95	26	3899.9	-20	+95.5
AWS	25	2110	1710	26	3820	-20	+95.5
	-30, 25, 85	2132.5	1732.5	26	3865	-20	+95.5
	25	2155	1755	26	3910	-20	+95.5

■ TERMINAL INFORMATION

No.	SYMBOL	DESCRIPTION
1	GND	Ground terminal. Please connect this terminal with ground plane as close as possible for excellent RF performance.
2	TRX4	RF transmitting/receiving port.
3	TRX5	RF transmitting/receiving port.
4	TRX6	RF transmitting/receiving port.
5	GND	Ground terminal. Please connect this terminal with ground plane as close as possible for excellent RF performance.
6	GND	Ground terminal. Please connect this terminal with ground plane as close as possible for excellent RF performance.
7	ANT	RF transmitting/receiving port. Please connect an inductor and capacitor with GND terminal for enhancing ESD protection, keeping zero DC Voltage at RF ports, and good RF characteristics.
8	GND	Ground terminal. Please connect this terminal with ground plane as close as possible for excellent RF performance.
9	GND	Ground terminal. Please connect this terminal with ground plane as close as possible for excellent RF performance.
10	TX2	RF transmitting port. This port is connected the LPF for GSM1800/1900 TX band.
11	GND	Ground terminal. Please connect this terminal with ground plane as close as possible for excellent RF performance.
12	GND	Ground terminal. Please connect this terminal with ground plane as close as possible for excellent RF performance.
13	TX1	RF transmitting port. This port is connected the LPF for GSM850/900 TX Band.
14	GND	Ground terminal. Please connect this terminal with ground plane as close as possible for excellent RF performance.
15	RX2	RF receiving port.
16	GND	Ground terminal. Please connect this terminal with ground plane as close as possible for excellent RF performance.
17	RX1	RF receiving port.
18	TRX1	RF transmitting/receiving port.
19	TRX2	RF transmitting/receiving port.
20	TRX3	RF transmitting/receiving port.
21	GND	Ground terminal. Please connect this terminal with ground plane as close as possible for excellent RF performance.
22	VDD	Positive voltage supply terminal. The positive voltage (+2.5 to +5.0V) has to be supplied. Please connect a bypass capacitor with GND terminal for excellent RF performance.
23	VCTL4	Control signal input terminal. This terminal is set to High-Level (+1.35 to +5.0V) or Low-Level (0 to +0.45V).
24	VCTL3	Control signal input terminal. This terminal is set to High-Level (+1.35 to +5.0V) or Low-Level (0 to +0.45V).
25	VCTL2	Control signal input terminal. This terminal is set to High-Level (+1.35 to +5.0V) or Low-Level (0 to +0.45V).
26	VCTL1	Control signal input terminal. This terminal is set to High-Level (+1.35 to +5.0V) or Low-Level (0 to +0.45V).

NJG1686MHH

APPLICATION CIRCUIT

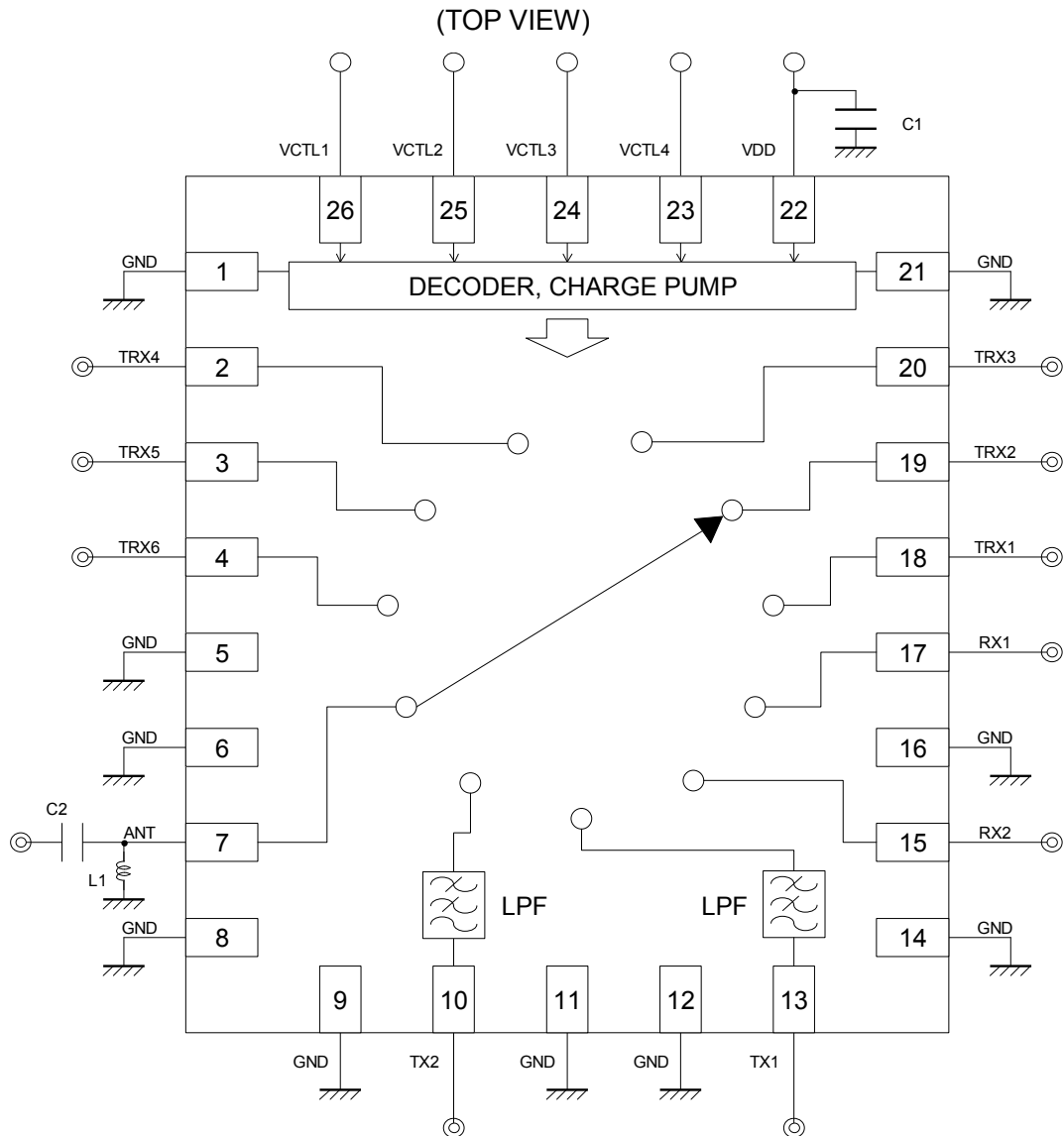

No DC blocking capacitors are required on all RF ports, unless DC is biased externally.

PARTS LIST

No.	Parameters	Note
C1	1000 pF	MURATA (GRM15)
C2 *1	47pF	MURATA (GRM15)
L1 *1	56 nH	TDK (MLG1005S)

*1: The use of the inductor L1 and the capacitor C2 are needed in order to keep zero DC Voltage at RF ports, enhancing ESD protection level, and for good RF characteristics.

PCB LAYOUT

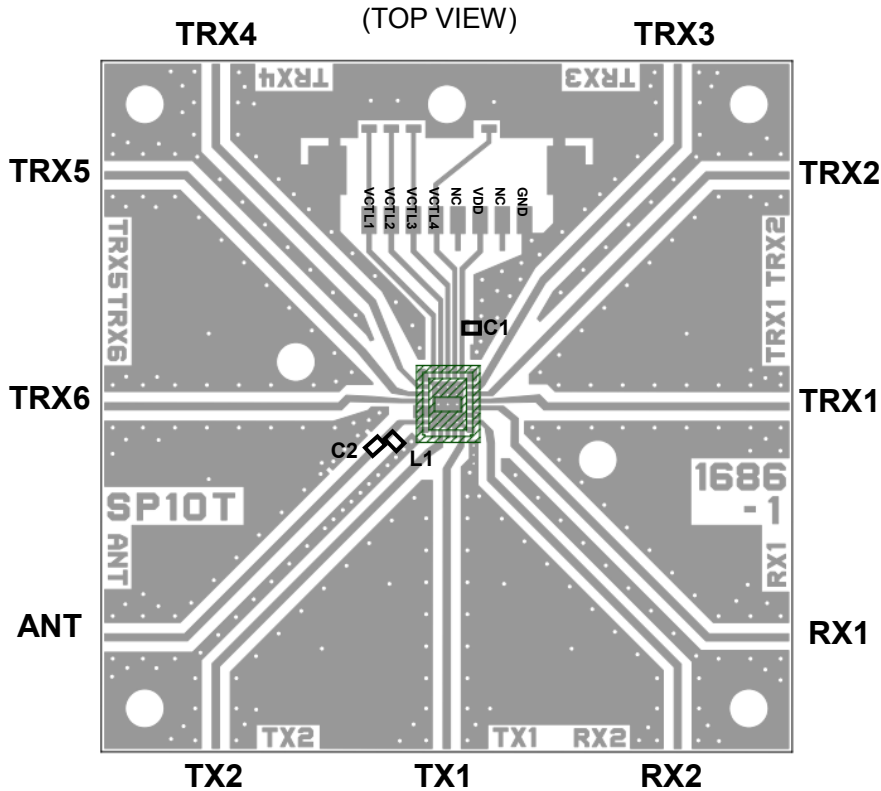





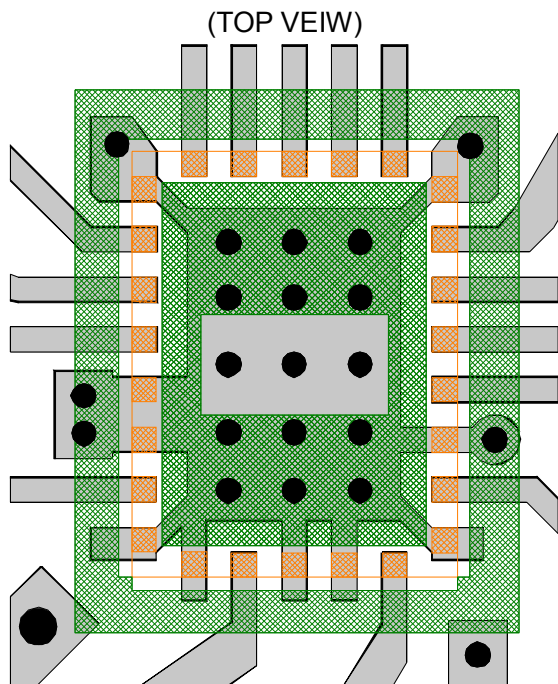

Losses of PCB and connectors, Ta=+25°C

Frequency (MHz)	ANT-TX2, RX1,2, TRX2,3,4,5 Loss (dB)	ANT-TX1, TRX1,6 Loss (dB)
787	0.36	0.34
915	0.38	0.35
960	0.37	0.34
1910	0.58	0.53
2170	0.64	0.57
2690	0.72	0.66

PCB SIZE: 38.9 x 38.9 mm
 PCB: FR-4, t=0.2mm
 MICROSTRIP LINE WIDTH: 0.4mm
 Areas being hatched are covered with resist.

<PCB LAYOUT GUIDELINE>



-  PCB
-  PKG Terminal
-  PKG Outline
-  Resist
-  GND Via Hole
Diameter: $\phi = 0.15\text{mm}, 0.3\text{mm}$

PRECAUTIONS

- [1] No DC block capacitors are required for RF ports unless DC is biased externally.
- [2] For avoiding the degradation of RF performance, the bypass capacitor (C1) should be placed as close as possible to VDD terminal
- [3] For good RF performance, all GND terminals are must be connected to PCB ground plane of substrate, and through - holes for GND should be placed the IC near.

NJG1686MHH

RECOMMENDED FOOTPRINT PATTERN (EQFN26-HH PACKAGE REFERENCE)

 : Land

 : Mask (Open area) *Metal mask thickness : 100μm

 : Resist (Open area)

PKG : 3.4mm x 2.6mm

Pin pitch : 0.4mm

<TYPE 1> *

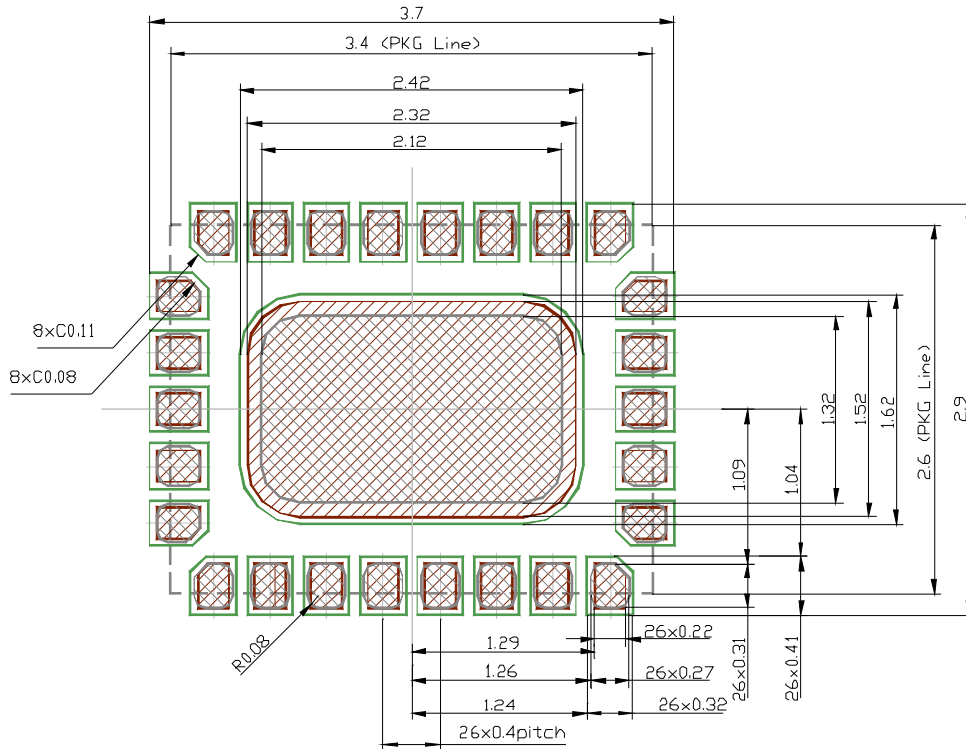

<TYPE 2> *

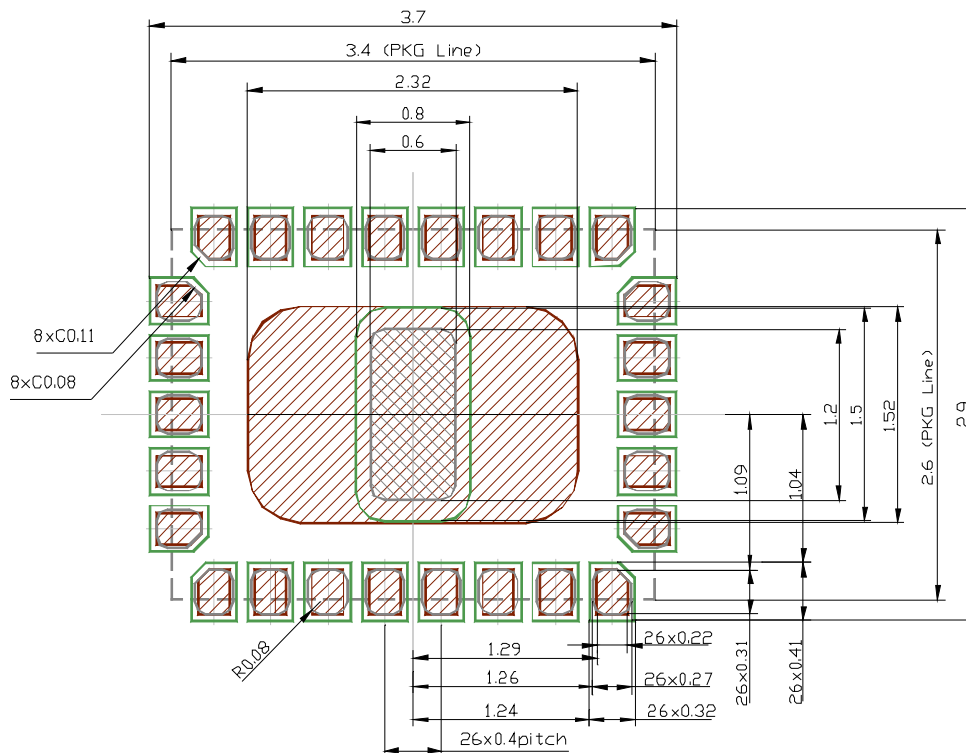

* There is no difference in the characteristics using both of TYPE 1 and TYPE 2.

PACKAGE OUTLINE (EQFN26-HH)

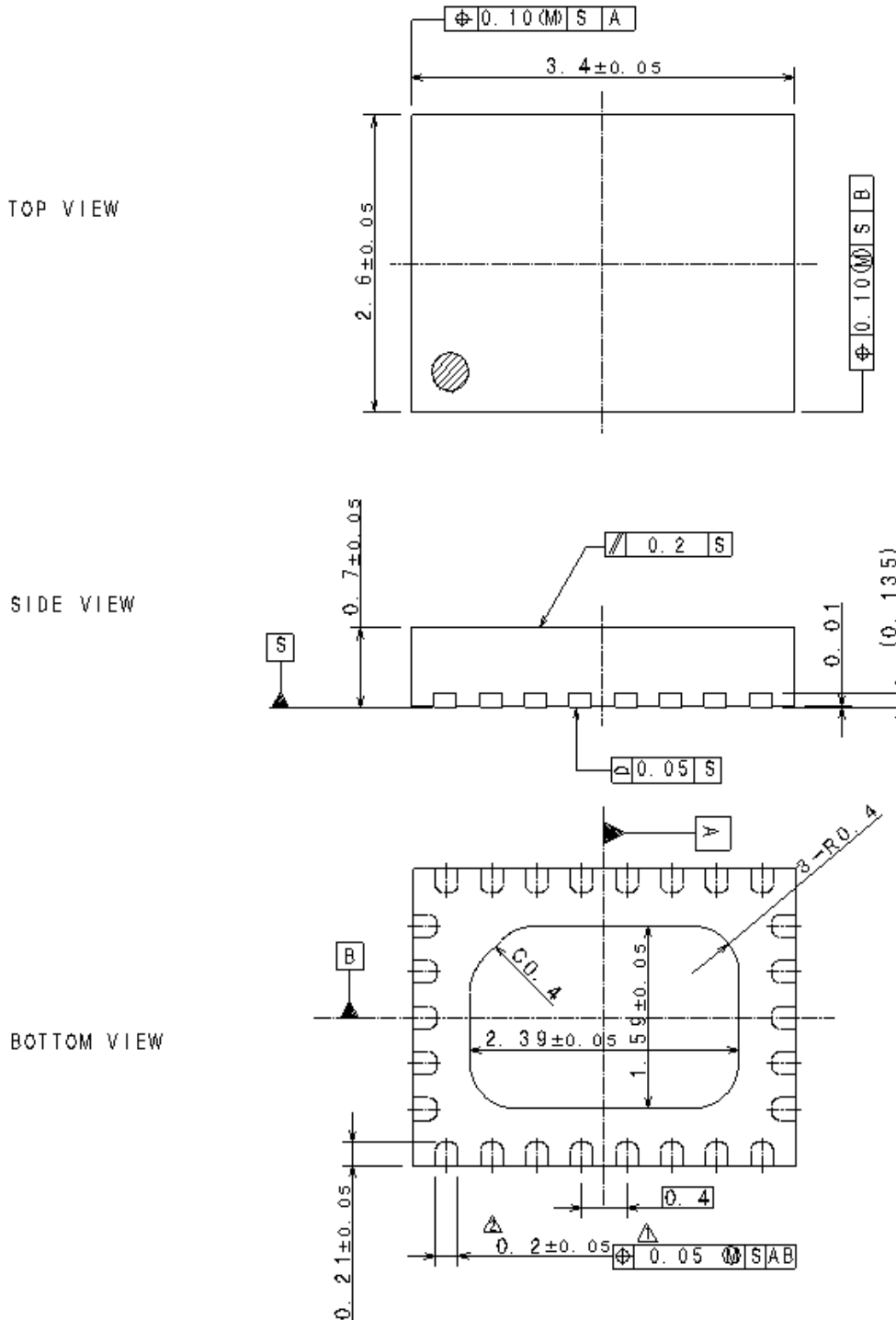

Units	: mm
Board	: Cu
Terminal treat	: SnBi
Molding material	: Epoxy resin
Weight	: 18mg

Cautions on using this product

This product contains Gallium-Arsenide (GaAs) which is a harmful material.

- Do NOT eat or put into mouth.
- Do NOT dispose in fire or break up this product.
- Do NOT chemically make gas or powder with this product.
- To waste this product, please obey the relating law of your country.

[CAUTION]

The specifications on this databook are only given for information, without any guarantee as regards either mistakes or omissions. The application circuits in this databook are described only to show representative usages of the product and not intended for the guarantee or permission of any right including the industrial rights.

This product may be damaged with electric static discharge (ESD) or spike voltage. Please handle with care to avoid these damages.