

COBP PHOTO REFLECTOR

■ GENERAL DESCRIPTION

The NJL5908AR is the compact surface mount type photo reflector, which is permitted the Lead(Pb)-free reflow soldering (260 , 2 Times). The NJL5908AR has realized the compact package compared with conventional product/NJL5902R-2.

■ FEATURES

- Miniature, thin package : 1.06mm × 1.46mm × 0.5mm
- Low operating dark current : 2μA max.
- Pb free solder re-flowing permitted : 260°C, 2times
- Built-in visible light cut-off filter

■ APPLICATIONS

- Detecting the location of Lens unit for Cellular Phone's camera module
- Detecting the watch hand for radio controlled watch
- Detecting the location of CD/DVD optical pickup head
- Detecting the rotation of various motors
- Paper edge detection and mechanism timing detection of facsimile, copy machine etc

■ ABSOLUTE MAXIMUM RATINGS (Ta=25°C)

PARAMETER	SYMBOL	RATINGS	UNIT
Emitter			
Forward Current (Continuous)	IF	20	mA
Reverse Voltage (Continuous)	VR	6	V
Power Dissipation	PD	45	mW
Detector			
Collector Emitter Voltage	VCEO	16	V
Emitter-Collector Voltage	VECO	6	V
Collector Current	IC	10	mA
Collector Power Dissipation	PC	25	mW
Coupled			
Total Power Dissipation	Ptot	60	mW
Operating Temperature	Topr	-30 to +85	°C
Storage Temperature	Tstg	-40 to +100	°C
Reflow Soldering Temperature	Tsol	260	°C

■ ELECTRO-OPTICAL CHARACTERISTICS (Ta=25°C)

PARAMETER	SYMBOL	TEST CONDITION	MIN	TYP	MAX	UNIT
Emitter						
Forward Voltage	VF	IF=4mA	0.9	—	1.3	V
Reverse Current	IR	VR=6V	—	—	10	μA
Capacitance	Ct	VR=0V,f=1MHz	—	25	—	pF
Detector						
Dark Current	ICEO	VCE=10V	—	—	0.2	μA
Collector Emitter Voltage	VCEO	IC=100μA	16	—	—	V
Coupled						
Output Current*1	IO	IF=4mA,VCE=2V,d=0.7mm	92	—	230	μA
Operating Dark Current *2	ICEOD	IF=4mA,VCE=2V	—	—	2	μA
Rise Time	tr	IO=100μA,VCE=2V,RL=1KΩ,d=0.7mm	—	20	—	μs
Fall Time	tf	IO=100μA,VCE=2V,RL=1KΩ,d=0.7mm	—	20	—	μs

*1 Refer to OUTPUT CURRENT TEST CONDITION

*2 Iceod may increase according to the periphery situation of the surface mounted product.

■ OUTLINE (typ.)

Unit : mm

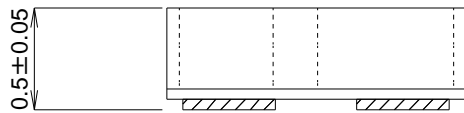
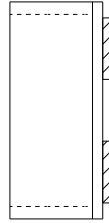
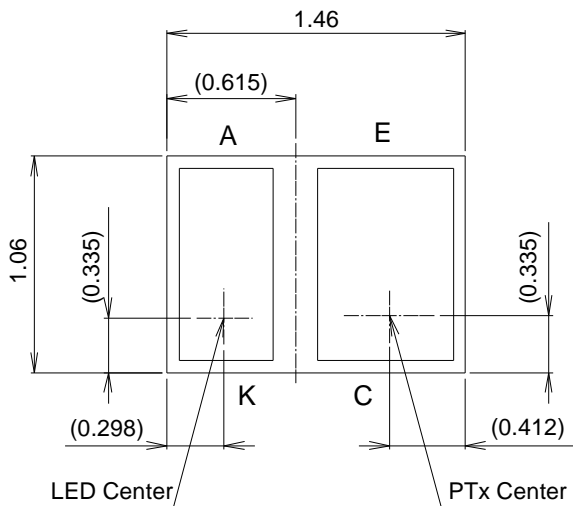

- A : Anode
- K : Cathode
- C : Collector
- E : Emitter

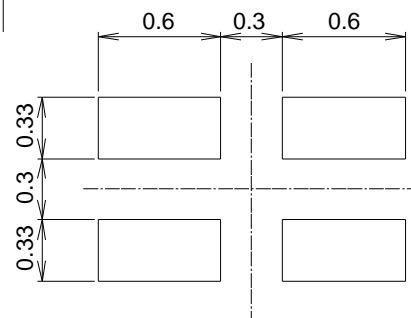
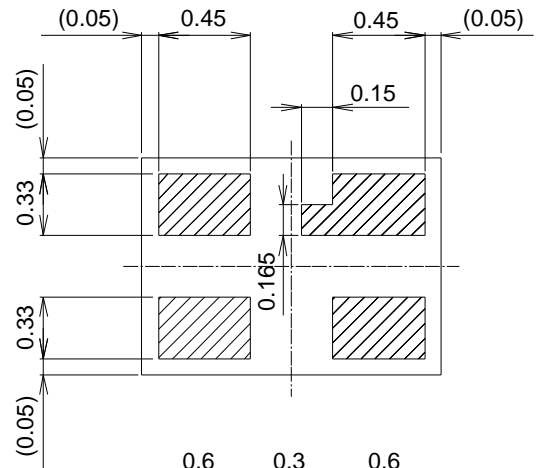

PCB Pattern

Tolerance : $\pm 0.1\text{mm}$

■ OUTPUT CURRENT TEST CONDITION

The infrared signal from LED is reflected at the aluminum surface

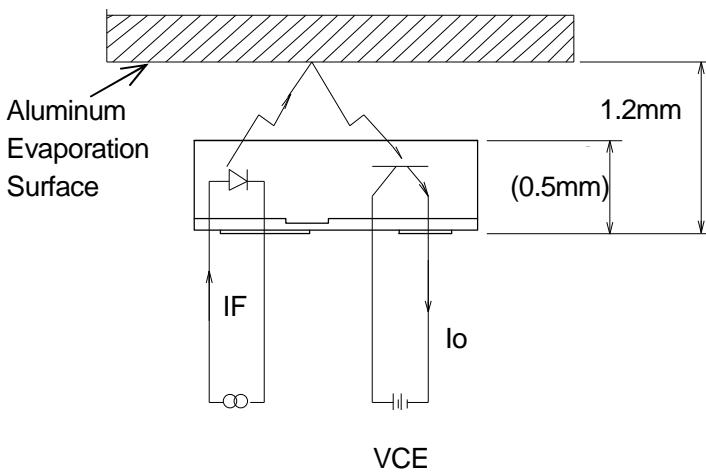

■ DARK CURRENT TEST CONDITION

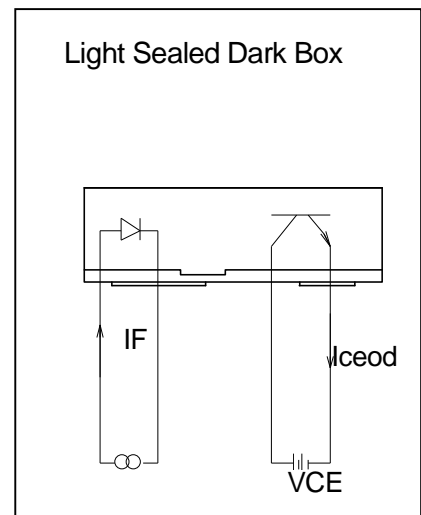

■ RESPONSE TIME TEST CONDITION

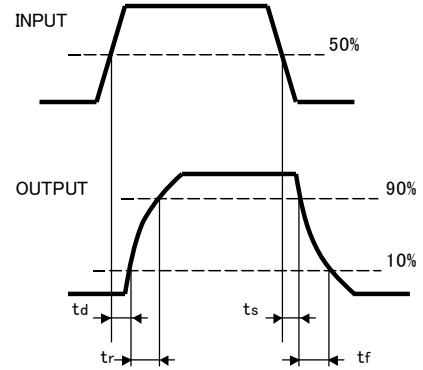
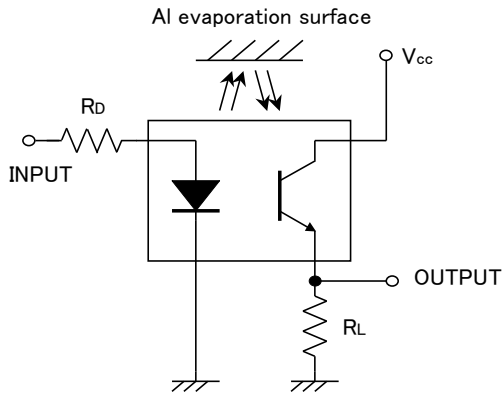

■ EDGE RESPONSE TEST CONDITION

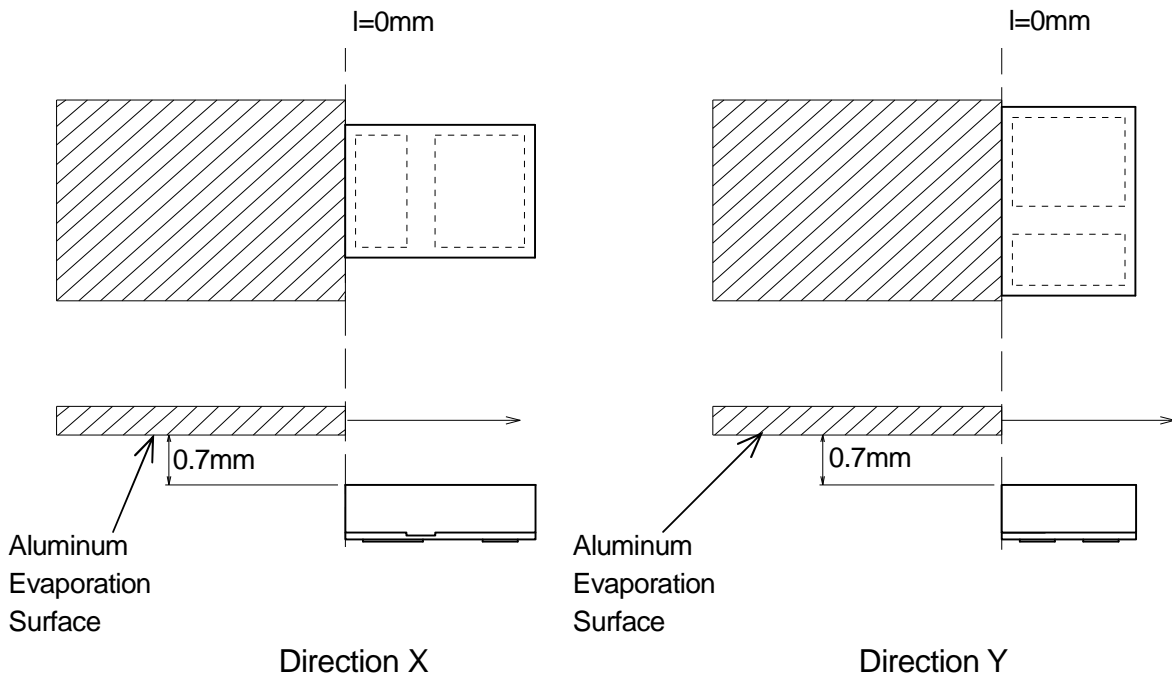

TYPICAL CHARACTERISTICS

Power Dissipation vs. Temperature

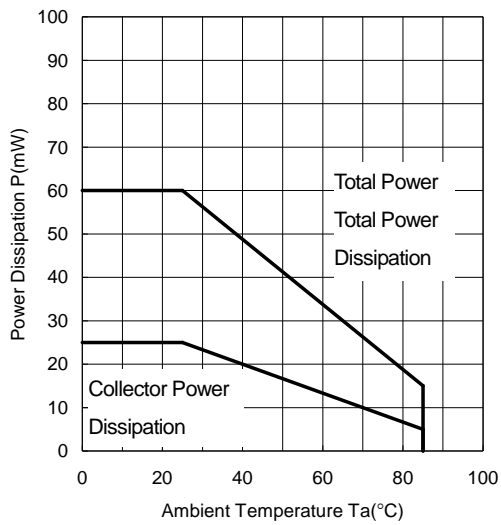

Forward Current vs. Temperature

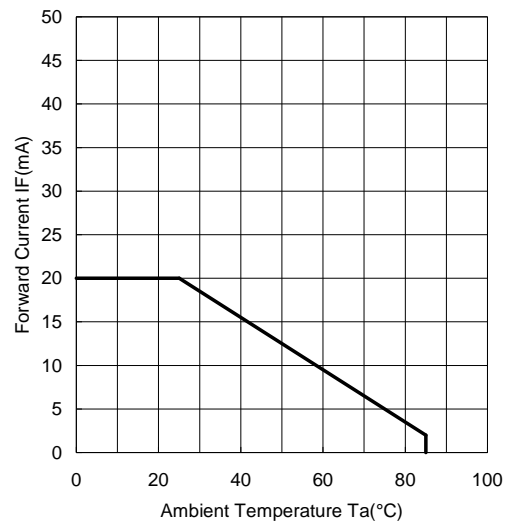

Forward Voltage vs. Forward Current

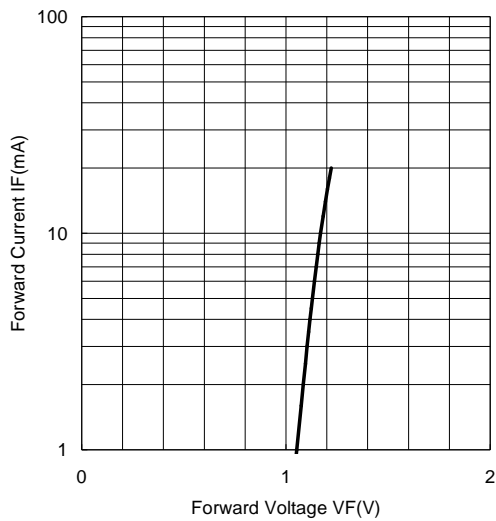

Forward Voltage vs. Temperature

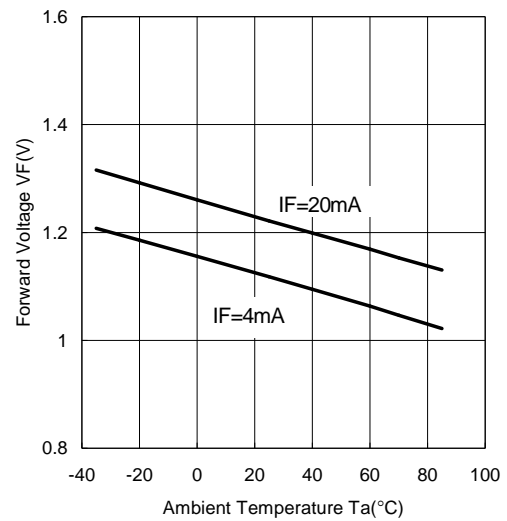

Dark Current vs. Temperature

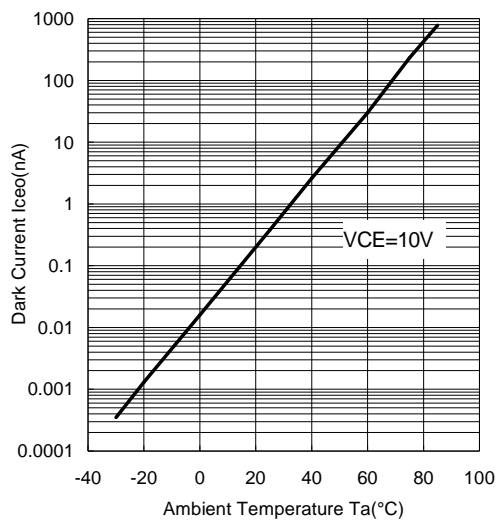

Operating Dark Current vs. Temperature

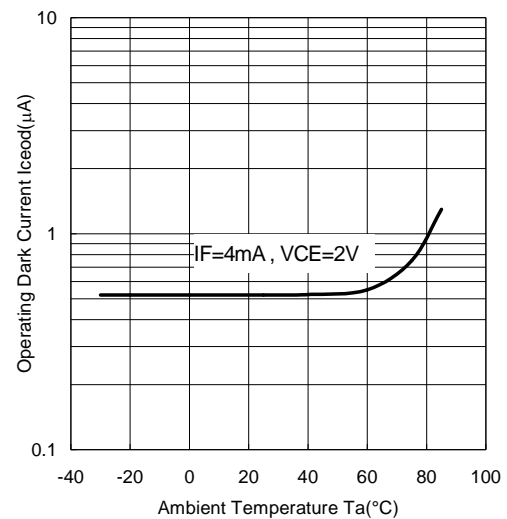

Output Current vs. Forward Current
(Ta=25°C)

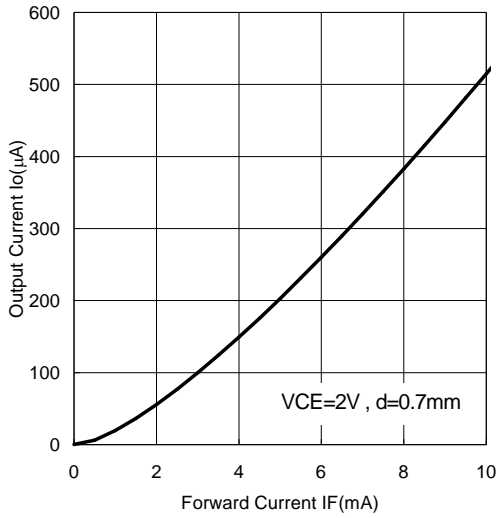

Output Current vs. Temperature

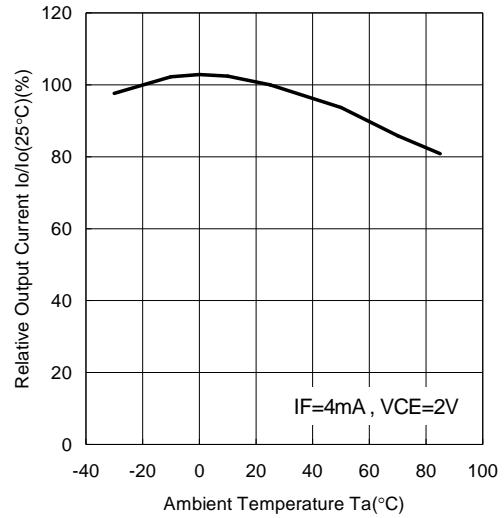

Output Characteristics (Ta=25°C)

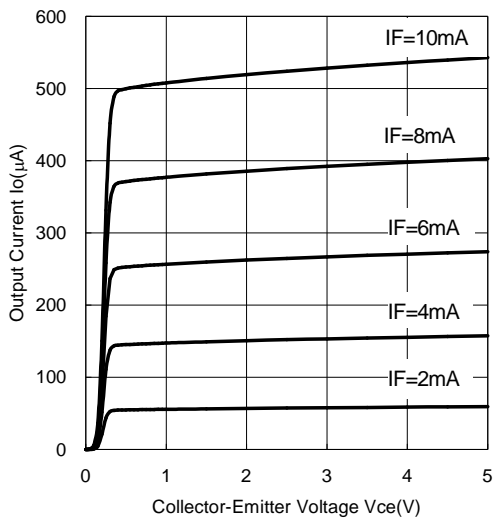

Vce Saturation (Ta=25°C)

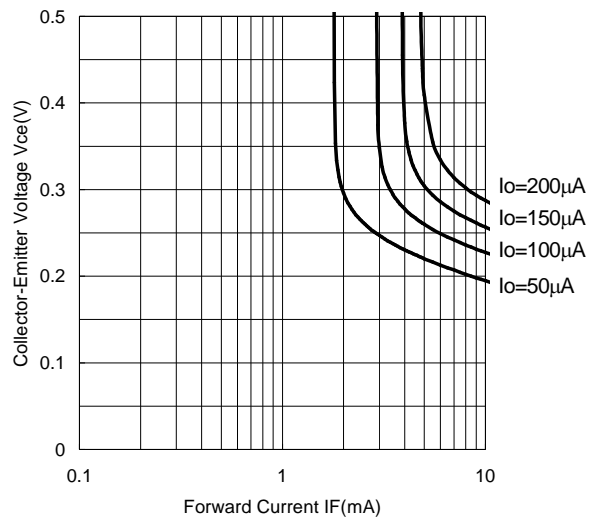

Output Current vs. Distance (Ta=25°C)

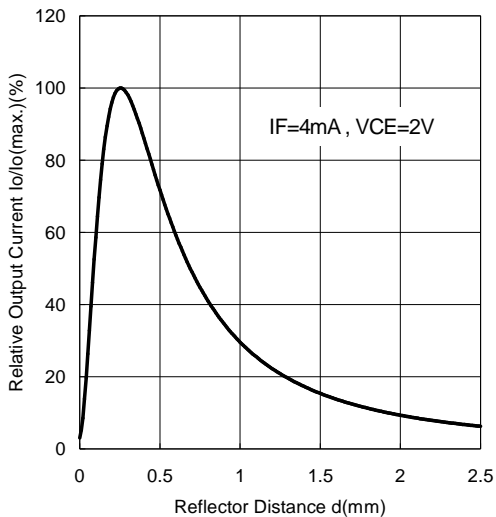

Output Current vs. Edge Distance (Ta=25°C)

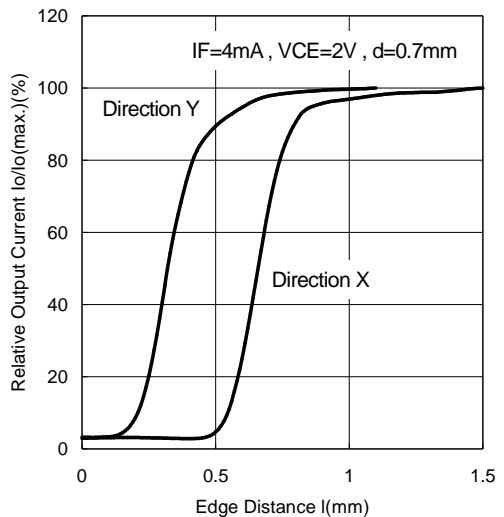

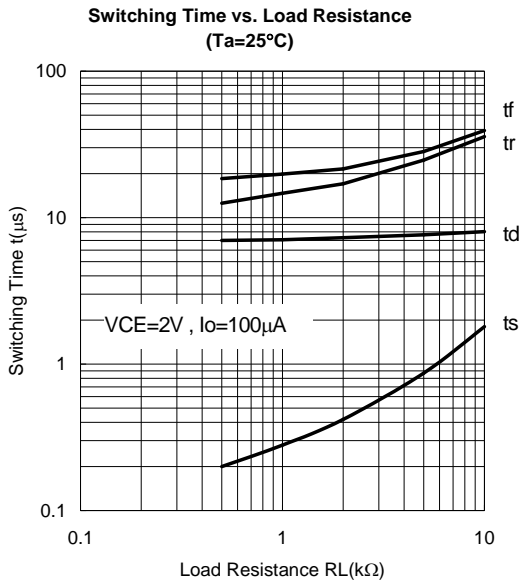
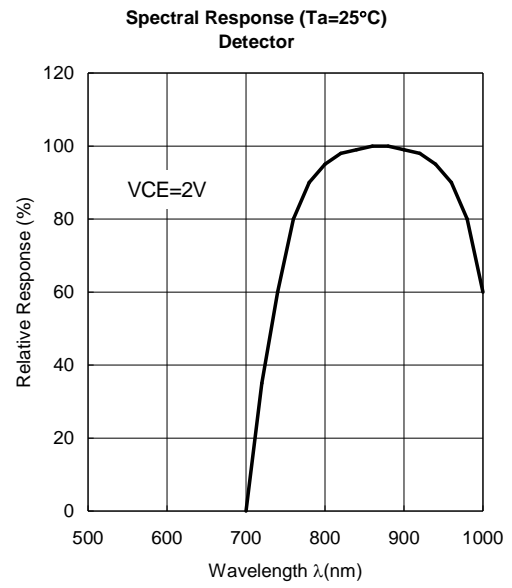
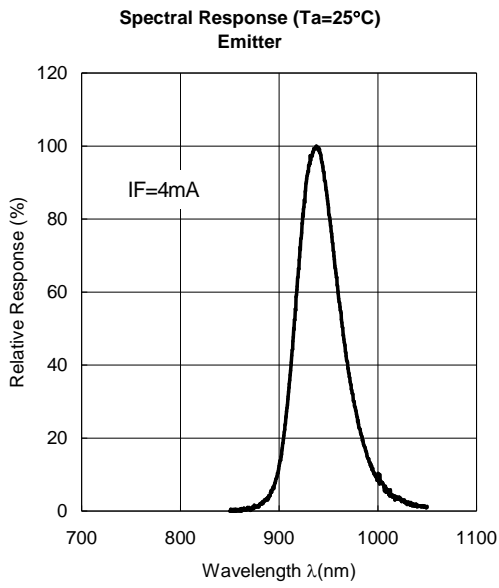

Attention: Please be aware that all data in the graph are just for reference and not for guarantee.

■ MOUNTING METHOD

NOTE

Mounting was evaluated with the following profiles in our company, so there was no problem.
However, confirm mounting by the condition of your company beforehand.

Mounting: Twice soldering is allowed.

■ INFRARED REFLOW SOLDERING METHOD

Recommended reflow soldering procedure

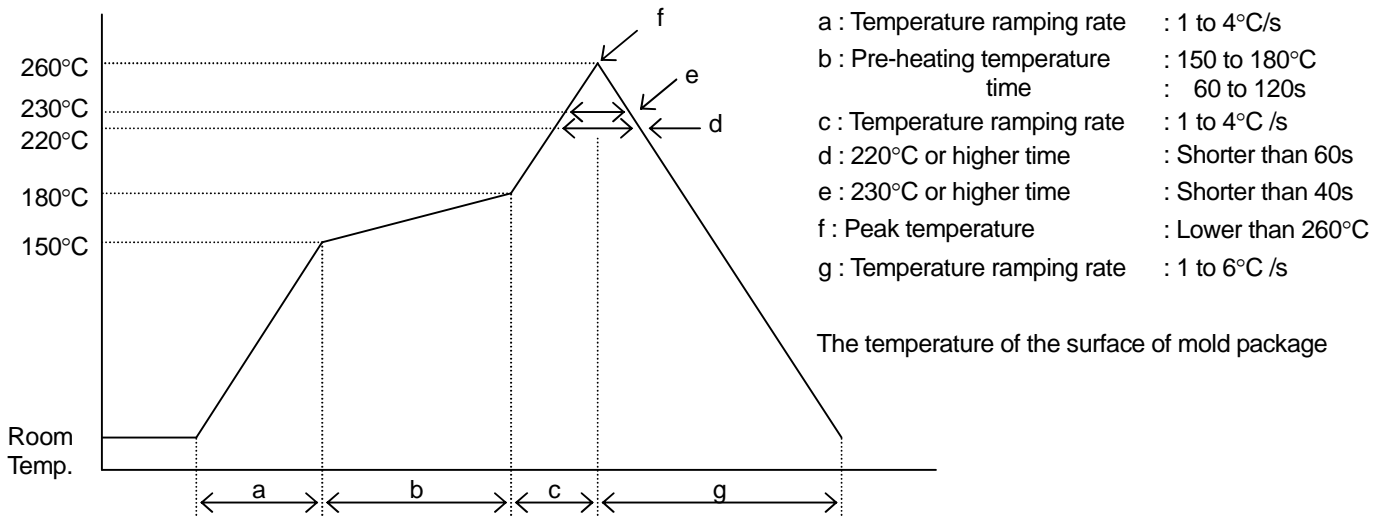

(NOTE1) Using reflow furnace with short wave infrared radiation heater such as halogen lamp

Regarding temperature profile, please refer to those fo reflow furnace.

In this case the resin surface temperature may become higher than lead terminals due to endothermic ally of black colored mold resin. Therefore, please avoid from direct exposure to mold resin.

(NOTE2) Other method

Such other methods of soldering as dipping the device into melted solder and vapor phase method (VPS) are not appropriate because the body of device will be heated rapidly. Therefore, these are not recommended to apply.

(NOTE3) The resin gets softened right after soldering, so, the following care has to be taken

Not to contact the lens surface to anything.

Not to dip the device into water or any solvents.

■ FLOW SOLDERING METHOD

Flow soldering is not possible.

■ IRON SOLDERING METHOD

Iron soldering is not possible.

■ CLEANING

Avoid washing the device after soldering by reflow method.

■ IC STORAGE CONDITIONS AND ITS DURATION

(1) Temperature and humidity ranges

Pack Sealing	Temperature:	5 to 40 [°C]
	Humidity:	40 to 80 [%]
Pack Opening	Temperature:	5 to 30 [°C]
	Humidity:	40 to 70 [%]

After opening the bag, solder products within 48h.

Avoid a dry environment below 40% because the products are easily damageable by the electrical discharge.

Store the products in the place where it does not create dew with the products due to a sudden change in temperature.

(2) When baking, place the reel vertically to avoid load to the side.

(3) Do not store the devices in corrosive-gas atmosphere.

(4) Do not store the devices in a dusty place.

(5) Do not expose the devices to direct rays of the sun.

(6) Do not allow external forces or loads to be applied to IC's.

(7) BE careful because affixed label on the reel might be peeled off when baking.

■ BAKING

In case of keeping expect above condition be sure to apply baking. (Heat-resistant tape)

Baking method: Ta=60°C, 48 to 72h, Three times baking is allowed

Ta=100°C, 2 to 6h, Three times baking is allowed

■ STORAGE DURATION

Within a year after delivering this device.

For the products stored longer than a year, confirm their terminals and solderability before they are used.

■ APPLICATION NOTES

(1) Attention in handling

Treat not to touch the light receiving and light emitting part.

Avoid to adhering the dust and any other foreign materials on the light receiving and light emitting part when using.

Never apply reverse voltage (VEC) of over 6V to the photo transistor when measuring the characteristics or adjusting the system. If applied, it causes to lower the sensitivity.

When LED has operated by voltage, it should be connected the resistor of current adjustment. Avoid to applying direct voltage to LED, because there is possibility that LED is destroyed.

When mounting, special care has to be taken on the mounting position and tilting of the device because it is very important to place the device to the optimum position to the object.

(2) Attention in designing

Avoid the entering ambient light into light receiving part for avoid the malfunction by ambient light. Furthermore, there is possibility of malfunction when there are the other mounted parts by near this product peripheral.

There will be changing characteristics by detection object. Refer to this datasheet and evaluate by actual detection object.

When LED has been applied continuous power on long period of time, the output current is dropped. If it uses by always applying power to LED, have to consider the circuit designing of including output current decrease.

PACKING SPECIFICATION

PACKING DIMENTIONS UNIT : mm

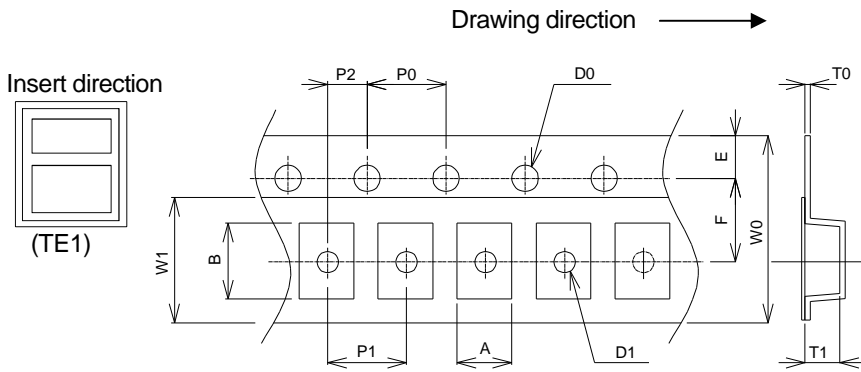

SYMBOL	DIMENSION	REMARKS
A	1.21 ±0.05	BOTTOM DIMENSION
B	1.66 ±0.05	BOTTOM DIMENSION
D0	φ1.50 ^{+0.1} ₋₀	
D1	φ0.50 ±0.05	
E	1.75 ±0.10	
F	3.50 ±0.05	
P0	4.00 ±0.10	
P1	4.00 ±0.10	
P2	2.00 ±0.05	
T0	0.20 ±0.05	
T1	0.65 ±0.05	
W0	8.00 ±0.10	
W1	5.40 ±0.10	THICKNESS 0.1MAX

* Carrier tape material : Polycarbonate(antistatic)
Cover tape material : Polyester(antistatic)

Taping Strength

Pull up the cover tape from the carrier tape, and when the opening angle comes around 10 to 15 , and the peeling-off strength is to be within the power of 20 to 70g.

Packaging

- 1) The taped products are to be rolled up on the taping reel as on the drawing.
- 2) Rolling up specification
 - 2-1) Start rolling : Carrier tape open space more than 20 Pieces.
 - 2-2) End of rolling : Carrier tape open space more than 20 Pieces, and 2 round of reel space at the cover tape only.
- 3) Taping quantity : 2,000 Pieces
- 4) Seal off after putting each reels in a damp proof bag with silica gel.

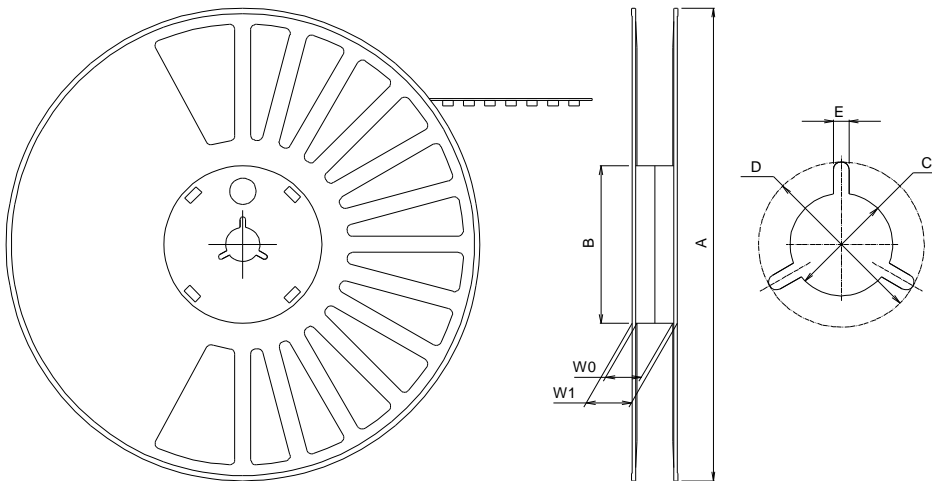

SYMBOL	DIMENSION
A	φ180 ±1.0
B	φ60 ±0.5
C	φ13 ±0.2
D	φ21 ±0.8
E	2.0 ±0.5
W0	9.0 ±0.5
W1	12.6 ±1.0

[CAUTION]
The specifications on this databook are only given for information , without any guarantee as regards either mistakes or omissions. The application circuits in this databook are described only to show representative usages of the product and not intended for the guarantee or permission of any right including the industrial rights.