

TruSurround[™]

by SRS (S)

PRELIMINARY

Passive Matrix TruSurround[™] 3D Audio Processor

■GENERAL DESCRIPTION

The **NJM2188** is a Passive Matrix TruSurround[™] 3D audio processor. It regenerates the full surround sound field directly from any kinds of surround encoded stereo input(Lt/Rt) signals.

After the internal passive matrix circuit decodes Lt/Rt signal into 4 channel signals, the TruSurround virtualizer encodes them into 2 channel surround signals again.

Accordingly any pre-processors decoding into 4 channel signals are not required.

The **NJM2188** also includes the SRS 3D-STEREO, and regenerates a 3D sound field from normal L/R input.

The **NJM2188** is suitable for TV, mini component, CD radio cassette, multimedia speaker system ,and others.

■PACKAGE

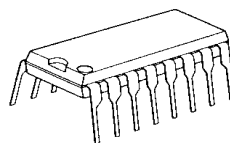

NJM2188D

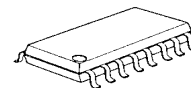

NJM2188M

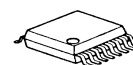

NJM2188V

■FEATURES

- Operating Voltage (4.7 to 13V)
- Maximum Input Voltage (1.5Vrms typ. at $V^+ \geq 11V$)
- Low Output Noise (32 μ Vrms typ. at TRU mode)
- SRS 3D-STEREO FUNCTION (Two-grade Switch for 3D Effect)
- BYPASS FUNCTION (THROUGH)
- Bipolar Technology
- Package Outline DIP16, DMP16, SSOP16

The TruSurround technology right incorporated in the NJM2188 are owned by SRS Labs, a U.S. Corporation and licensed to New Japan Radio Co., Ltd. SRS is protected under U.S. and foreign patents issued and/or pending. TruSurround and the , are trademarks of SRS Labs, Inc. in the United States and selected foreign countries. Neither the purchase of the NJM2188, nor the corresponding sale of audio enhancement equipment conveys the right to sell commercialized recordings made with any TruSurround technology.

SRS Labs requires that all users of the NJM2188 must enter into a license agreement directly with SRS Labs if the royalty is not included in the purchase price. SRS Labs also requires any users to comply with all rules and regulations as outlined in the SRS Trademark Usage Manual.

For further information, please contact:

SRS Labs., Inc.

2909 Daimler Street. Santa Ana, CA 92705 USA

Tel:949-442-1070 Fax:949-852-1099

<http://www.srslabs.com>

NJM2188

■BLOCK DIAGRAM

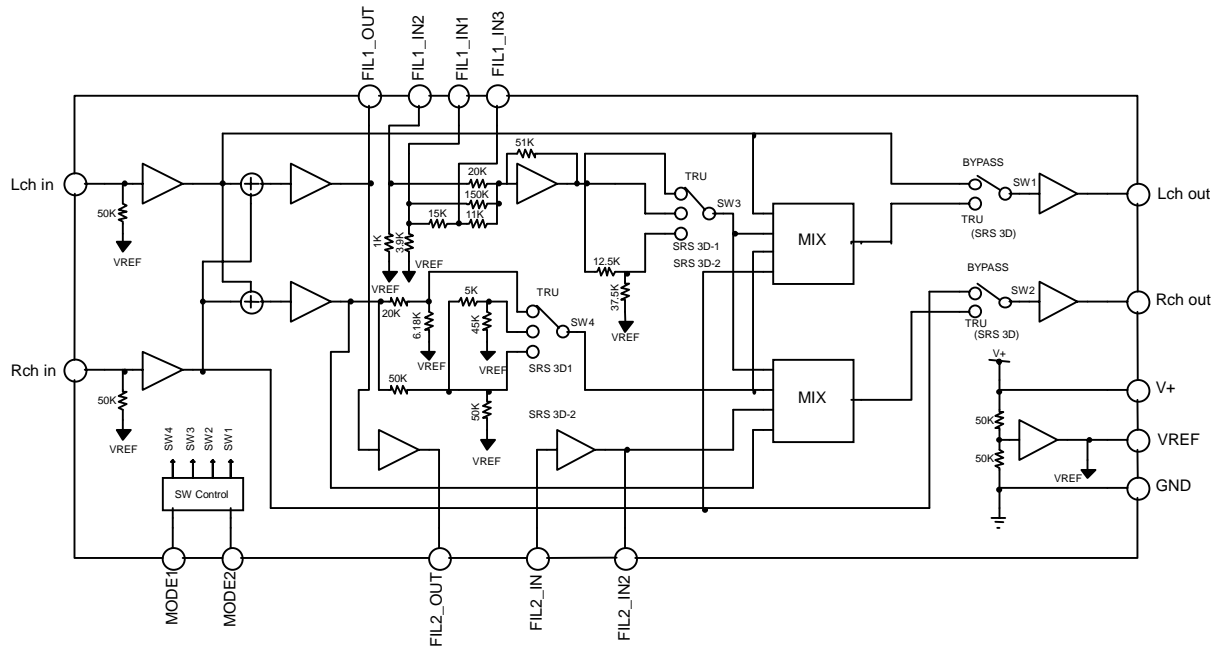

■PIN CONFIGURATION

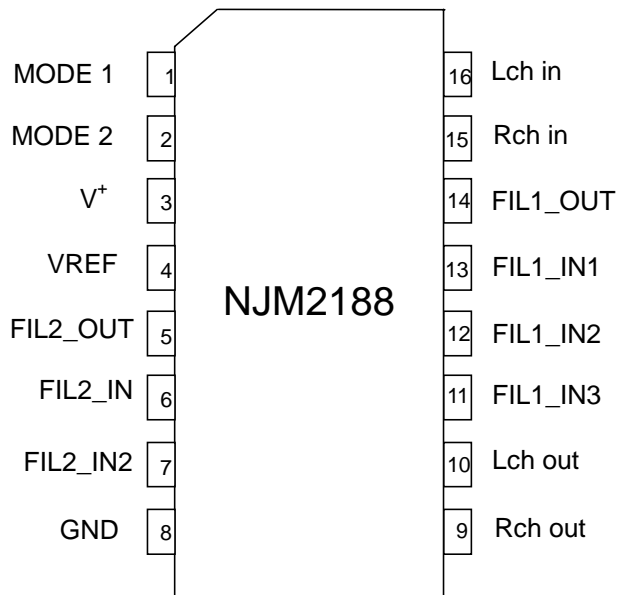

No.	Symbol	Function
1	MODE1	Mode Switch
2	MODE2	Mode Switch
3	V ⁺	Supply Voltage 4.5V to 13V
4	V _{REF}	V ⁺ /2 OUTPUT
5	FIL2_OUT	Perspective Network_2 output
6	FIL2_IN	Perspective Network_2 input
7	FIL2_IN2	Perspective Network_2 input2
8	GND	Ground
9	Rch OUT	Rch OUTPUT
10	Lch OUT	Lch OUTPUT
11	FIL1_IN3	Perspective Network_1 INPUT3
12	FIL1_IN2	Perspective Network_1 INPUT2
13	FIL1_IN1	Perspective Network_1 INPUT1
14	FIL1_OUT	Perspective Network_1 OUTPUT
15	Rch IN	Rch INPUT
16	Lch IN	Lch INPUT

■ABSOLUTE MAXIMUM RATING (Ta=25°C)

PARAMETER	SYMBOL	RATING	UNIT
Supply Voltage	V ⁺	15	V
Power Dissipation	P _D	(DIP16) 500 (DMP16) 300 (SSOP16) 300	mW
Operating Temperature Range	T _{opr}	-40 to +85	°C
Storage Temperature Range	T _{stg}	-40 to +125	°C

■ELECTRICAL CHARACTERISTICS(V⁺=12V,Ta=25°C)

PARAMETER	SYMBOL	CONDITION	CONDITION				MIN	TYP	MAX	UNIT
			IN		OUT	MODE				
			L	R						
Operating Voltage	V ⁺		-	-	-	-	4.7	12.0	13.0	V
Supply Current	I _{cc}	No Signal	0	0	-	BYPASS	-	9.0	13.5	mA
			0	0	-	TRU				
			0	0	-	SRS 3D-1				
Reference Voltage	V _{REF}	V ⁺ /2	-	-	-	-	5.5	6.0	6.5	V
Maximum Input Voltage	V _{INMAX}	f=1kHz THD=3%	V _{IN}	0	L	BYPASS	11.0 (3.55)	12.0 (3.98)	-	dBV (V _{rms})
			0	V _{IN}	R					
		f=125Hz THD=3%	V _{IN}	0	L	TRU	4.5 (1.67)	6.5 (2.11)	-	
			V _{IN}	0	R		7.3 (2.32)	9.3 (2.92)	-	
			V _{IN}	V _{IN}	L		3.9 (1.57)	5.9 (1.97)	-	
		f=125Hz THD=3%	V _{IN}	0	L	SRS3D-1	7.5 (2.37)	9.5 (3.0)	-	
			V _{IN}	0	R		7.3 (2.32)	9.3 (2.92)	-	
			V _{IN}	V _{IN}	L		4.0 (1.58)	6.0 (2.0)	-	
		f=125Hz THD=3%	V _{IN}	0	L	SRS3D-2	7.5 (2.37)	9.5 (3.0)	-	
			V _{IN}	0	R		7.5 (2.37)	9.5 (3.0)	-	
			V _{IN}	V _{IN}	L		4.5 (1.68)	6.5 (2.11)	-	

NJM2188

■ELECTRICAL CHARACTERISTICS(V⁺=12V,Ta=25°C)

PARAMETER	SYMBOL		CONDITION				MIN	TYP	MAX	UNIT
			IN		OUT	MODE				
			L	R						
Output Noise	V _{NOISE}	A-Weighting R _g =0Ω	0	0	L	BYPASS	-	-110 (3.16)	-100 (10.0)	dBV (μVrms)
			0	0	R					
			0	0	L	TRU	-	-90 (31.6)	-84 (63.1)	
			0	0	R					
			0	0	L	SRS3D-1	-	-90 (31.6)	-84 (63.1)	
			0	0	R					
Total Harmonic Distortion	THD	f=1kHz V _{IN} =-10dB	V _{IN}	0	L	BYPASS	-	0.01	-	%
			0	V _{IN}	R					
			V _{IN}	0	L	TRU	-	0.10	-	
			V _{IN}	0	R					
			V _{IN}	0	L	SRS3D-1	-	0.10	-	
			V _{IN}	0	R					
Bypass Gain	G _{Bypass2}	f=1kHz	V _{IN}	0	L	BYPASS	-1.0	0.0	1.0	dB
			0	V _{IN}	R					
Passive Gain	G _{L_L/R_L-L}	f=1kHz	V _{IN}	0	L	TRU	0.2	2.2	4.2	dB
	G _{L_L/R_L-R}	f=1kHz	V _{IN}	0	R					
SRS 3D Gain	G _{SRS3D}	f=1kHz	V _{IN}	0	L	SRS3D-1	-4.8	-2.8	-0.8	dB
			V _{IN}	0	R					
			0	V _{IN}	L					
		f=1kHz	V _{IN}	0	L	SRS3D-2	-5.8	-3.8	-1.8	
			V _{IN}	0	R					
			0	V _{IN}	L					
MODE Select Control Voltage	V _{MODE}	V _{IN} =High Level	-	-	-	-	2.0	-	V ⁺	V
		V _{IN} =Low Level	-	-	-	-	0.0	-	0.7	

MODESELECT SWITCH

MODE	MODE1	MODE2	NOTE
BYPASS	L	L	INPUT THROUGH MODE
TRU	L	H	Passive Matrix TruSurround
SRS 3D-1	H	L	SRS 3D STEREO MODE Space 100% Center 90%
SRS 3D-2	H	H	SRS 3D STEREO MODE Space 90% Center 70%

APPLICATION CIRCUIT

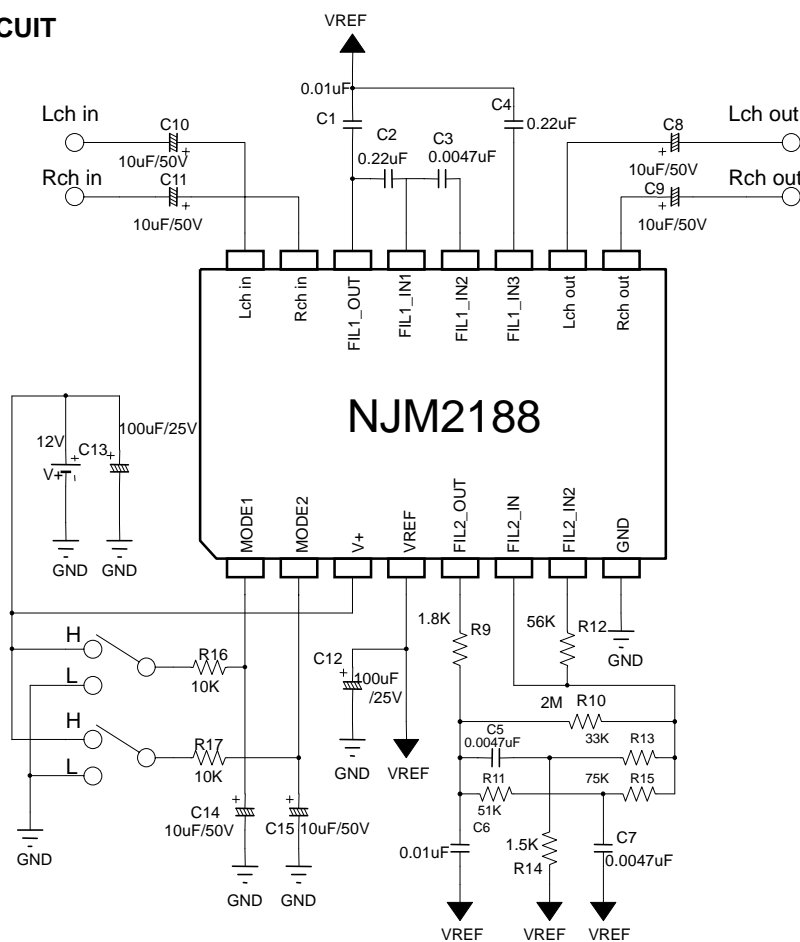

PARTS NO.	VALUE	Tolerance	PARTS NO.	VALUE	Tolerance
C1,C6	0.01 μ F	\pm 5%	R12	56k	\pm 5%
C2,C4	0.22 μ F	\pm 5%	R13	33k	\pm 5%
C3,C5,C7	0.0047 μ F	\pm 5%	R14	1.5k	\pm 5%
C8,C9,C10,C11	10 μ F		R15	75k	\pm 5%
C14,C15	10 μ F		R16,R17	10k	\pm 5%
C12,C13	100 μ F				
R9	1.8k	\pm 5%			
R10	2M	\pm 5%			
R11	51k	\pm 5%			

TYPICAL CHARACTERISTICS

**FREQUENCY RESPONSE
BYPASS MODE**

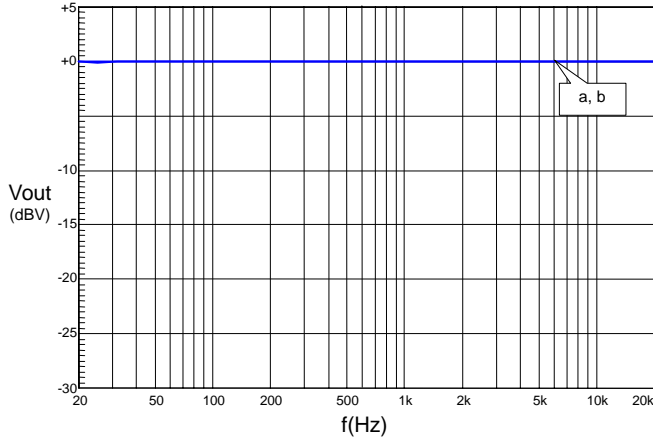

a: $V_{in} = 0\text{dBV}$ Lch \Rightarrow $V_{out} = \text{Lch}$
 b: $V_{in} = 0\text{dBV}$ Rch \Rightarrow $V_{out} = \text{Rch}$
 $V^+ = 12\text{V}$, $0\text{dBV} = 1\text{Vrms}$

**FREQUENCY RESPONSE
TRU(Lt/Rt) MODE**

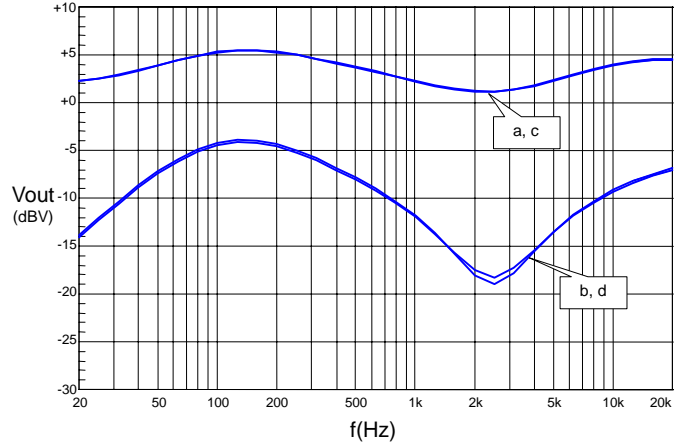

a: $V_{in} = 0\text{dBV}$ Lch \Rightarrow $V_{out} = \text{Lch}$
 b: $V_{in} = 0\text{dBV}$ Lch \Rightarrow $V_{out} = \text{Rch}$
 c: $V_{in} = 0\text{dBV}$ Rch \Rightarrow $V_{out} = \text{Rch}$
 d: $V_{in} = 0\text{dBV}$ Rch \Rightarrow $V_{out} = \text{Lch}$
 $V^+ = 12\text{V}$, $0\text{dBV} = 1\text{Vrms}$

**FREQUENCY RESPONSE
SRS 3D-1 MODE**

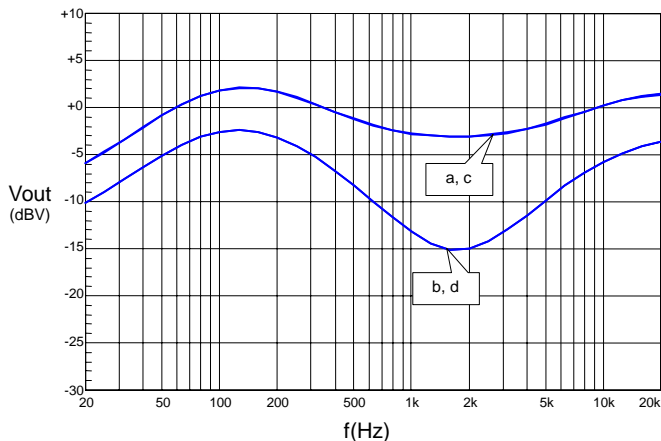

a: $V_{in} = 0\text{dBV}$ Lch \Rightarrow $V_{out} = \text{Lch}$
 b: $V_{in} = 0\text{dBV}$ Lch \Rightarrow $V_{out} = \text{Rch}$
 c: $V_{in} = 0\text{dBV}$ Rch \Rightarrow $V_{out} = \text{Rch}$
 d: $V_{in} = 0\text{dBV}$ Rch \Rightarrow $V_{out} = \text{Lch}$
 $V^+ = 12\text{V}$, $0\text{dBV} = 1\text{Vrms}$

**FREQUENCY RESPONSE
SRS 3D-2 MODE**

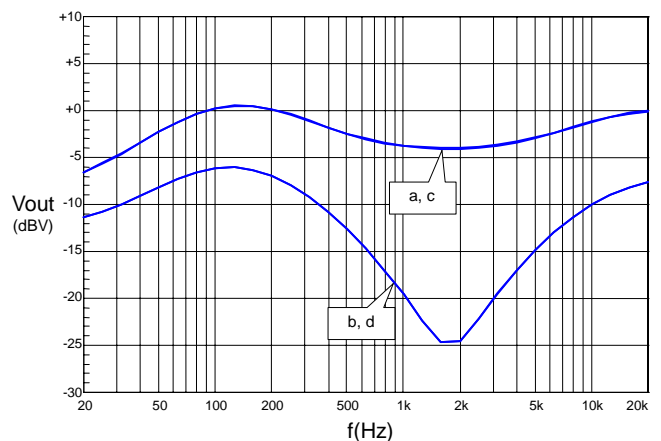

a: $V_{in} = 0\text{dBV}$ Lch \Rightarrow $V_{out} = \text{Lch}$
 b: $V_{in} = 0\text{dBV}$ Lch \Rightarrow $V_{out} = \text{Rch}$
 c: $V_{in} = 0\text{dBV}$ Rch \Rightarrow $V_{out} = \text{Rch}$
 d: $V_{in} = 0\text{dBV}$ Rch \Rightarrow $V_{out} = \text{Lch}$
 $V^+ = 12\text{V}$, $0\text{dBV} = 1\text{Vrms}$

**TOTAL HARMONIC DISTORTION vs. INPUT VOLTAGE
BYPASS MODE**

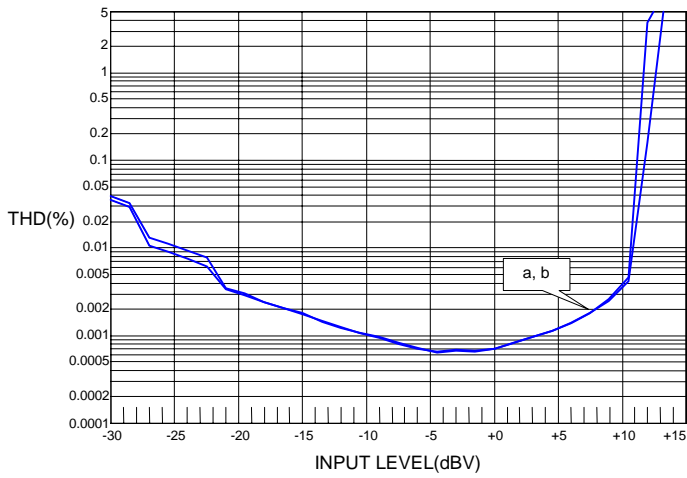

a: Vin = 1kHz Lch ⇒ Vout = Lch
 b: Vin = 1kHz Lch ⇒ Vout = Rch
 V⁺=12V

**TOTAL HARMONIC DISTORTION vs. INPUT VOLTAGE
TRU MODE**

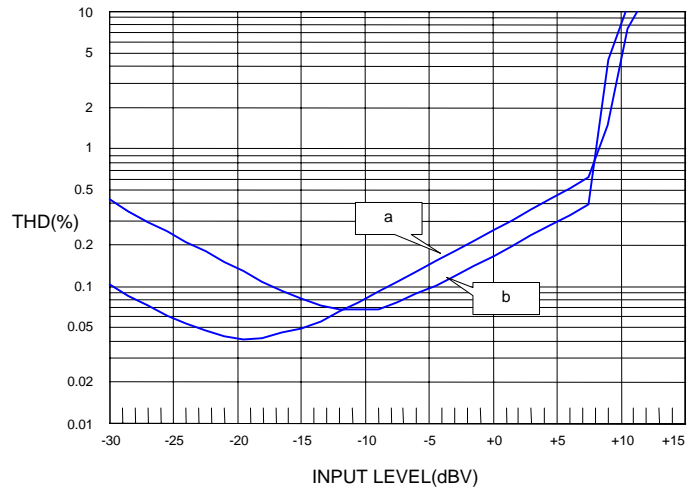

a: Vin = 1kHz Lch ⇒ Vout = Lch
 b: Vin = 1kHz Lch ⇒ Vout = Rch
 V⁺=12V

**TOTAL HARMONIC DISTORTION vs. INPUT VOLTAGE
SRS 3D-1 MODE**

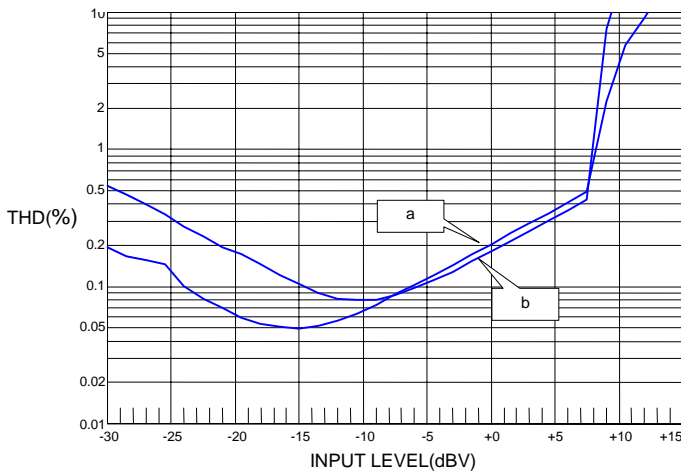

a: Vin = 1kHz Lch ⇒ Vout = Lch
 b: Vin = 1kHz Lch ⇒ Vout = Rch
 V⁺=12V

**TOTAL HARMONIC DISTORTION vs. INPUT VOLTAGE
SRS 3D-2 MODE**

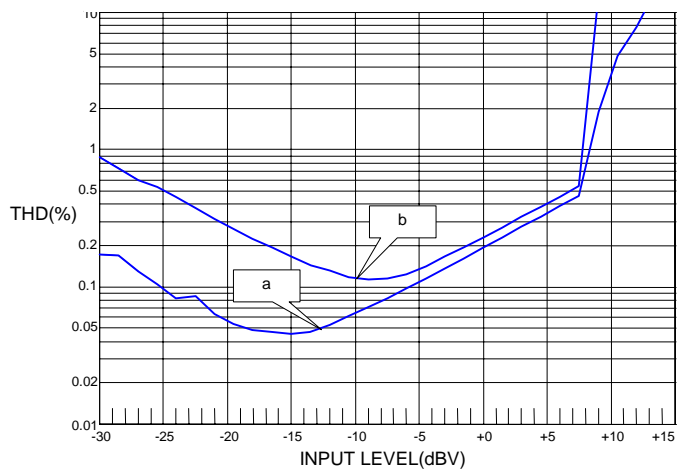

a: Vin = 1kHz Lch ⇒ Vout = Lch
 b: Vin = 1kHz Lch ⇒ Vout = Rch
 V⁺=12V

[CAUTION]
 The specifications on this databook are only given for information, without any guarantee as regards either mistakes or omissions. The application circuits in this databook are described only to show representative usages of the product and not intended for the guarantee or permission of any right including the industrial rights.