



SRS TruBass Bass Enhancement Processor

■GENERAL DESCRIPTION

The **NJM2192A** is a Bass Enhancement Processor, based on SRS TruBass technology.

The **NJM2192A** eliminates the need for large speakers to create low frequency fundamental tones, and it enhances and complements subwoofer performance.

The **NJM2192A** is suitable for audio applications which are speaker system for mini components, CD radio cassette, multimedia speaker systems, TV and others.

■PACKAGE OUTLINE

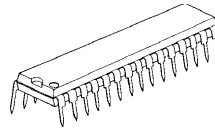

NJM2192AL

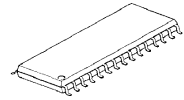

NJM2192AM

■FEATURES

- Operating Voltage 4.7 to 13V
- Punch Control
- Internal Bass Gain Control Switch
- Bypass Function (Through)
- Internal Mode Switch
- External Adjustment for Speaker Size (Small, Medium, Large)
- Bipolar Technology
- Package Outline SDIP30, SDMP30

The TruBass technology right incorporated in the **NJM2192A** are owned by SRS Labs, a U.S. Corporation and licensed to New Japan Radio Co., Ltd. TruBass is protected under U.S. and foreign patents issued and/or pending. TruBass and the , are trademarks of SRS Labs, Inc. in the United States and selected foreign countries. Neither the purchase of the **NJM2192A**, nor the corresponding sale of audio enhancement equipment conveys the right to sell commercialized recordings made with any SRS technology.

SRS Labs requires that all users of the **NJM2192A** must enter into a license agreement directly with SRS Labs if the royalty is not included in the purchase price. SRS Labs also requires any users to comply with all rules and regulations as outlined in the SRS Trademark Usage Manual.

For further information, please contact:

SRS Labs, Inc.
2909 Daimler Street. Santa Ana, CA 92705 USA
Tel:949-442-1070 Fax:949-852-1099 <http://www.srslabs.com>

NJM2192A

www.DataSheet4U.com

■PIN CONFIGURATION

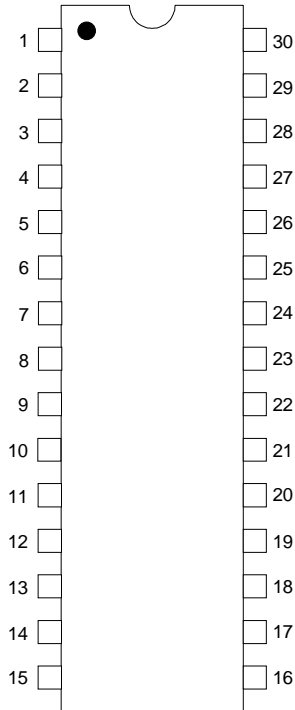

- | | |
|------------|-------------|
| 1. FILEOUT | 16. V+ |
| 2. FIL1 | 17. VREFOUT |
| 3. FIL2 | 18. VREFIN |
| 4. FIL3 | 19. GAINSW |
| 5. FIL4 | 20. MODE2 |
| 6. FIL5 | 21. MODE1 |
| 7. FIL6 | 22. BASSOUT |
| 8. FIL7 | 23. OTR |
| 9. PCOUT | 24. OUTL |
| 10. PCIN | 25. BASSINR |
| 11. FIL8 | 26. INR |
| 12. FIL9 | 27. BASSINL |
| 13. C1 | 28. INL |
| 14. C2 | 29. C3 |
| 15. GND | 30. C4 |

■TruBass BLOCK DIAGRAM

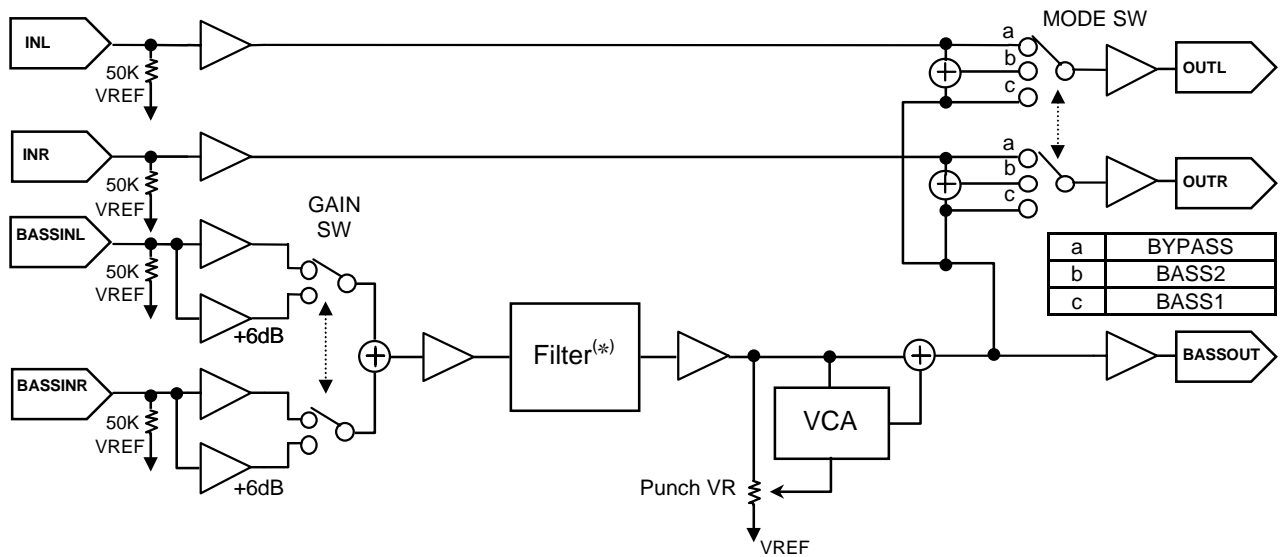

(*) Set the speaker size.

■SPEAKER SIZE SETTING

The standard setting of speaker size is as follows.(Reference)

- Large Mode : $f_o \leq 80\text{Hz}$
- Medium Mode : $80\text{Hz} < f_o \leq 150\text{Hz}$
- Small Mode : $150\text{Hz} < f_o \leq 250\text{Hz}$

Set the speaker size by TruBass effect of your application.

■ABSOLUTE MAXIMUM RATINGS (Ta=25°C)

PARAMETER	SYMBOL	RATING	UNIT
Supply Voltage	V^+	15	V
Power Dissipation	P_D	700	mW
Operating Temperature Range	T_{opr}	-40 to +85	°C
Storage Temperature Range	T_{stg}	-40 to +125	°C

■ELECTRICAL CHARACTERISTICS ($V^+=12V, T_a=25^\circ C, V_{IN}=-20dBV(100mV_{rms})$, Speaker Size : Medium)

PARAMETER	SYMBOL		TEST CONDITION					MIN.	TYP.	MAX.	UNIT
			IN		OUT	MODE	PUNCH VR				
			L	R							
Operating Voltage	V^+		-	-	-	-	-	4.7	12.0	13.0	V
Supply Current	I_{CC}	No Signal	0	0	-	BYPASS	-	6.6	11.6	16.6	mA
			0	0	-	BASS1	MAX	6.6	11.6	16.6	
			0	0	-	BASS2	MAX	6.6	11.6	16.6	
Reference Voltage	V_{REF}	$V^+/2$	0	0	-	-	-	5.8	6.0	6.2	V
Maximum Input Voltage	V_{IM}	f=1kHz THD=3%	V_{IN}	-	L	BYPASS	-	10.7 (3.1)	11.7 (3.8)	-	dBV (V _{rms})
			-	V_{IN}	R						
		f=100Hz THD=3% Gain "L"	V_{IN}	V_{IN}	L	BASS1	MAX	-6.3 (0.5)	-4.3 (0.6)	-	
			V_{IN}	V_{IN}	R						
		f=100Hz THD=3% Gain "L"	V_{IN}	V_{IN}	L	BASS2	MAX	-4.7 (0.6)	-2.7 (0.7)	-	
			V_{IN}	V_{IN}	R						
Output Noise	V_{NO}	Rg=0Ω A-Weighted	0	0	L	BYPASS	-	-	-105 (5.6)	-98 (12.6)	dBV (μV _{rms})
			0	0	R						
		Rg=0Ω A-Weighted Gain "L"	0	0	L	BASS2	MAX	-	-94 (20.0)	-88 (40.0)	
			0	0	R						
Total Harmonic Distortion	THD	f=1kHz $V_{IN}=-10dBV$	V_{IN}	-	L	BYPASS	-	-	0.005	0.01	%
			-	V_{IN}	R						
		f=100Hz Gain "L"	V_{IN}	V_{IN}	L	BASS1	MAX	-	0.1	1.0	
			V_{IN}	V_{IN}	R						
		f=100Hz Gain "L"	V_{IN}	V_{IN}	L	BASS2	MAX	-	0.1	1.0	
			V_{IN}	V_{IN}	R						
BYPASS Gain	GV_{BYP}	f=1kHz	V_{IN}	-	L	BYPASS	-	-1.0	0.0	1.0	dB
			-	V_{IN}	R						

NJM2192A

www.DataSheet4U.com

■ELECTRICAL CHARACTERISTICS ($V^+=12V, T_a=25^\circ C, V_{IN}=-20dBV(100mV_{rms})$, Speaker Size : Medium)

PARAMETER	SYMBOL	TEST CONDITION					MIN.	TYP.	MAX.	UNIT			
		IN		OUT	MODE	PUNCH VR							
BASS Gain	$G_{V_{BASS}}$	f=100Hz Gain "L"	V_{IN}	V_{IN}	L	BASS1	MAX	11.2	13.2	15.2	dB		
			V_{IN}	V_{IN}	R								
		f=100Hz Gain "L"	V_{IN}	V_{IN}	L	BASS1	MIN	-18.4	-14.4	-10.4		dB	
			V_{IN}	V_{IN}	R								
		f=100Hz Gain "H"	V_{IN}	V_{IN}	L	BASS1	MAX	15.7	17.7	19.7		dB	
			V_{IN}	V_{IN}	R								
		f=100Hz Gain "L"	V_{IN}	V_{IN}	L	BASS2	MAX	12.8	14.8	16.8		dB	
			V_{IN}	V_{IN}	R								
		f=100Hz Gain "H"	V_{IN}	V_{IN}	L	BASS2	MAX	16.6	18.6	20.6		dB	
			V_{IN}	V_{IN}	R								
		Switch Control Voltage	V_{IH}	19,20,21pin	-	-	-	-	2.0	-		V^+	V
			V_{IL}	19,20,21pin	-	-	-	-	0.0	-		0.7	

■MODE SWITCH FUNCTION

	MODE1	MODE2	NOTES
BYPASS (a)	L	-	Input Through
BASS1 (c)	H	L	Low Frequency Content of TruBass ⁽¹⁾
BASS2 (b)	H	H	TruBass Mode ⁽²⁾

(1) BASS1: The output signal is low frequency content of TruBass derived from the stereo audio signal.

(2) BASS2: TruBass Mode.

■BASS INPUT AMP GAIN SWITCH FUNCTION

To Increase the TruBass effect with the GAIN Switch.

	GAIN	NOTES
Gain Low	L	Normal Position
Gain High	H	Gain +6dB

INPUT TERMINAL OPERATING INSTRUCTION

NJM2192As input equip 4 terminals INL(28pin), INR(26pin), BASSINL(27pin) and BASSINR(25pin).

“Normal Setting”

Short INL and BASSINL, INR and BASSINR at the normal TruBass mode.

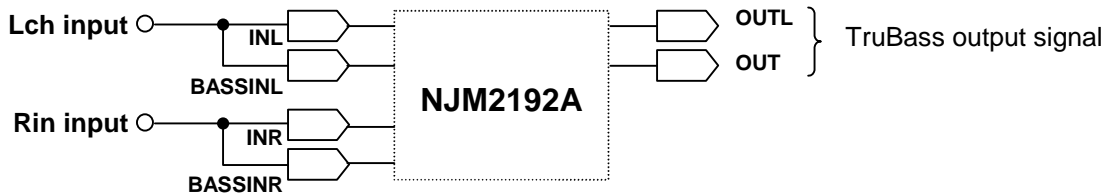

“Connect to the other surround ICs(TruSurround, SRS, etc.)”

If NJM2192A is used with the other surround ICs, the low frequency signal is possible to be amplified by the other surround ICs. Then the audio stereo signal input into the BASSIN L/R, and the other surround signal input into INL/R.

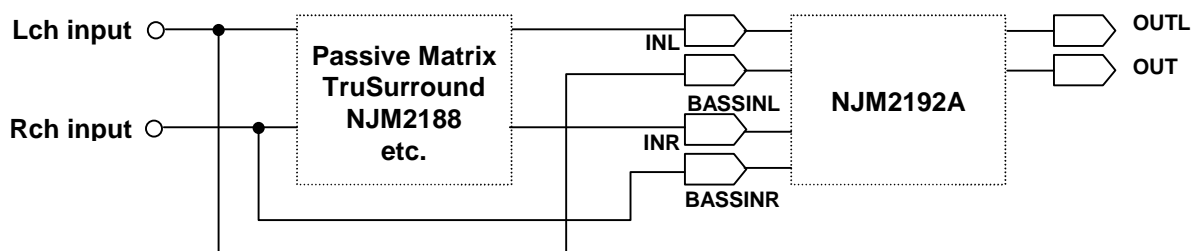

“Adjust TruBass effect”

Insert an attenuator before the BASSIN L/R if necessary.

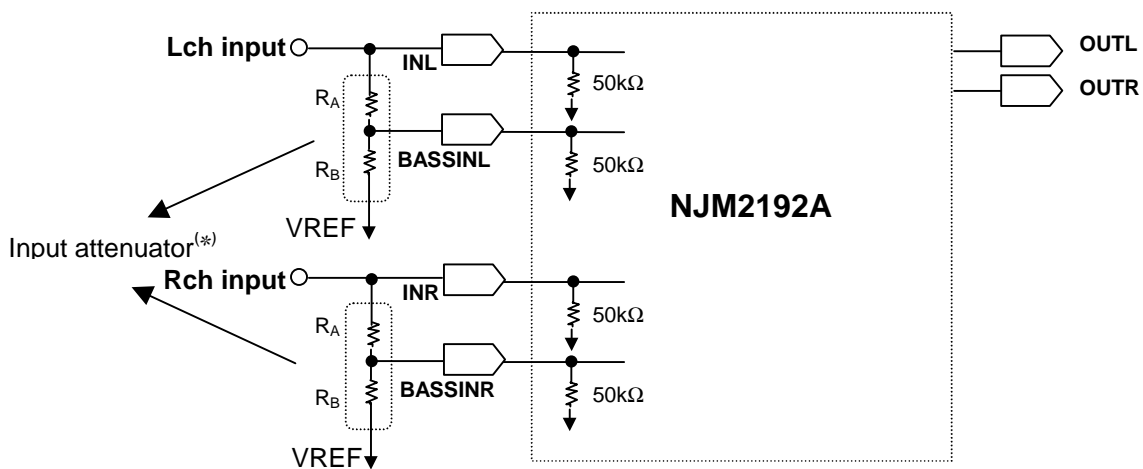

(*) Set the attenuator : $(R_A+R_B) \geq 50k\Omega$

NJM2192A

www.DataSheet4U.com

■PIN DESCRIPTION



NO.	SYMBOL	FUNCTION	EQUIVALENT CIRCUIT	VOLTAGE
10 29	PCIN C3	PUNCH Control VR Filter Input		$V+/2$
3 30	FIL2 C4	Filter Input		$V+/2$
1 17 22 23 24	FILOUT VREFOUT BASSOUT OUTR OUTL	Filter Output Vref Output TruBass Output (Low Frequency Content) Rch Audio Output Lch Audio Output		$V+/2$
2	FIL1	Filter Input		$V+/2$

NO.	SYMBOL	FUNCTION	EQUIVALENT CIRCUIT	VOLTAGE
4 5 7	FIL3 FIL4 FIL6	Filter Input		$V+/2$
6 8 11	FIL5 FIL7 FIL8	Filter Input		$V+/2$
9 12	PCOUT FIL9	PUNCH Control VR Filter Output		$V+/2$
13	C1	Filter Input		0V

NJM2192A

www.DataSheet4U.com

NO.	SYMBOL	FUNCTION	EQUIVALENT CIRCUIT	VOLTAGE
14	C2	Filter Input		0V
18	VREFIN	Vref Input		V+/2
19 20 21	GAINSW MODE2 MODE1	Gain SW MODE2 SW MODE1 SW		0V
25 26 27 28	BASSINR INR BASSINL INL	Audio Input		V+/2

NO.	SYMBOL	FUNCTION	EQUIVALENT CIRCUIT	VOLTAGE
15	GND	GND		0V
16	V+	V+		V+

NJM2192A

www.DataSheet4U.com

■BLOCK DIAGRAM

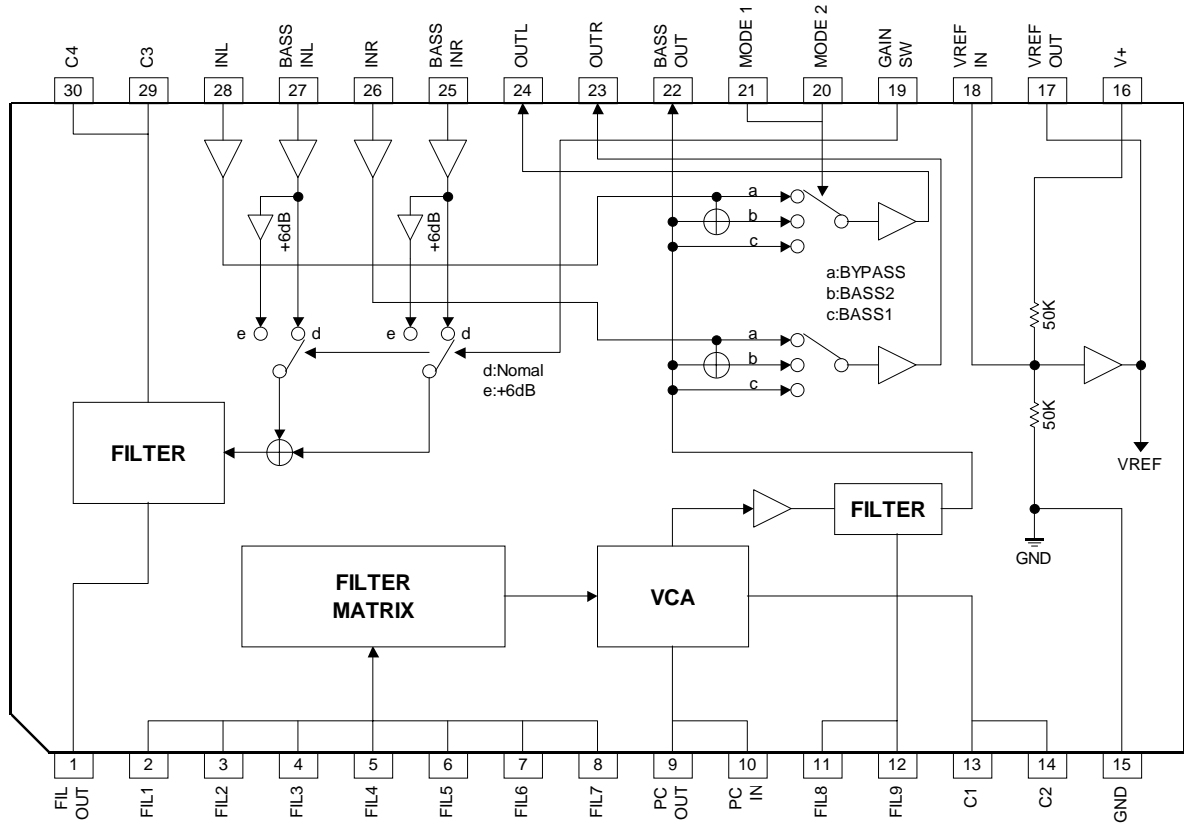

No.	SYMBOL	FUNCTION	No.	SYMBOL	FUNCTION
1	FILOUT	Filter Output	16	V+	Supply Voltage
2	FIL1	Filter Input	17	VREFOUT	V ⁺ /2 Output
3	FIL2	Filter Input	18	VREFIN	V ⁺ /2 Input
4	FIL3	Filter Input	19	GAINSW	Gain Switch
5	FIL4	Filter Input	20	MODE2	MODE2 Switch
6	FIL5	Filter Input	21	MODE1	MODE1 Switch
7	FIL6	Filter Input	22	BASSOUT	TruBass Output (Low Frequency Content) ⁽¹⁾
8	FIL7	Filter Input	23	OUTR	Rch Output
9	PCOUT	Punch Control VR	24	OUTL	Lch Output
10	PCIN	Punch Control VR	25	BASSINR	TruBass Input ⁽²⁾
11	FIL8	Filter Input	26	INR	Rch Input
12	FIL9	Filter Output	27	BASSINL	TruBass Input ⁽³⁾
13	C1	Filter Input	28	INL	Lch Input
14	C2	Filter Input	29	C3	Filter Input
15	GND	GND	30	C4	Filter Input

(1) The BASSOUT is low frequency signal derived from the stereo audio signal.

(2),(3) Refer to "■INPUT TERMINAL OPERATING INSTRUCTION"

APPLICATION CIRCUIT(1)

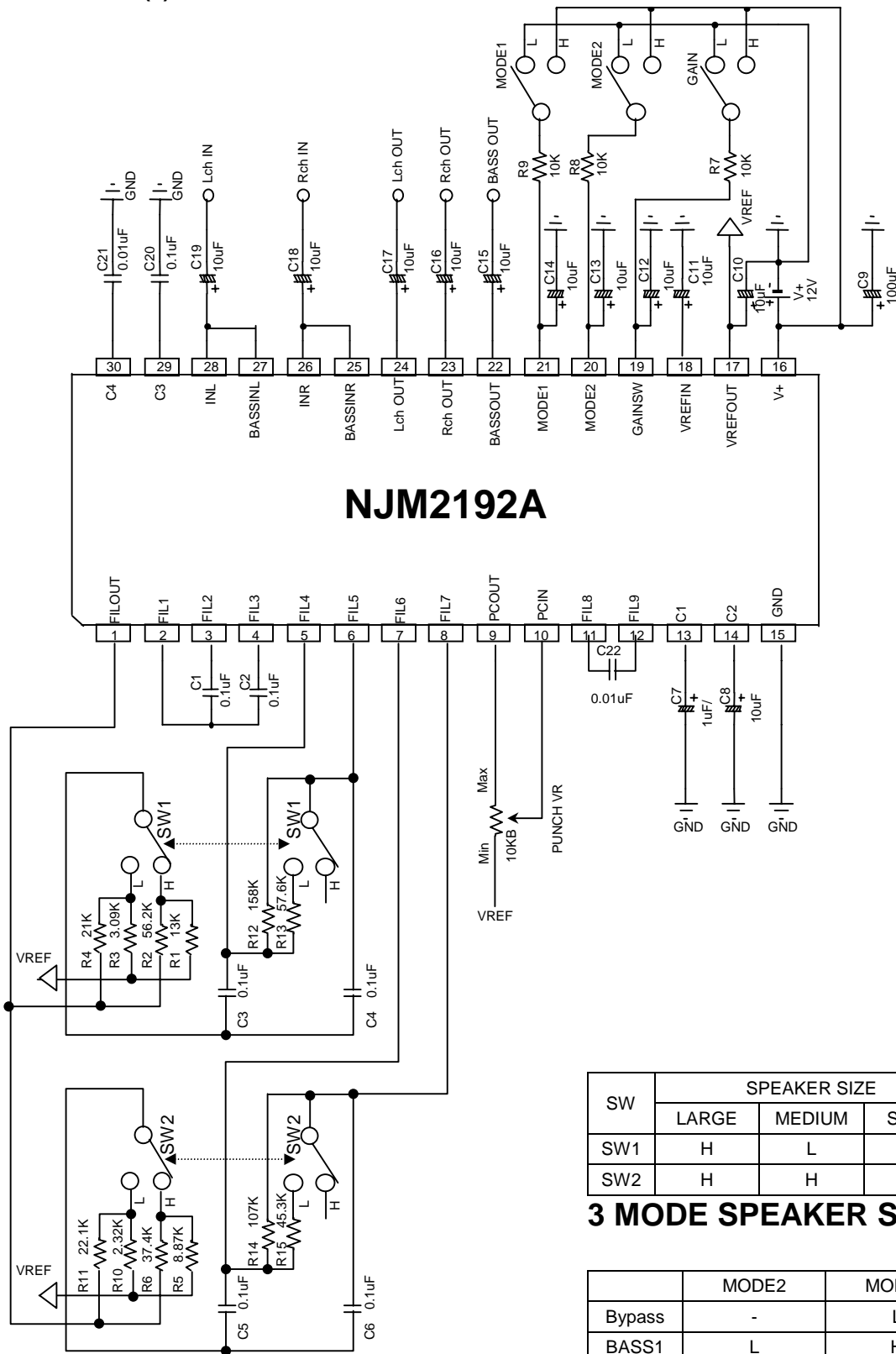

NJM2192A

SW	SPEAKER SIZE		
	LARGE	MEDIUM	SMALL
SW1	H	L	L
SW2	H	H	L

3 MODE SPEAKER SIZE

	MODE2	MODE1
Bypass	-	L
BASS1	L	H
BASS2	H	H

FUNCTION SETTING

NJM2192A

APPLICATION CIRCUIT(2)

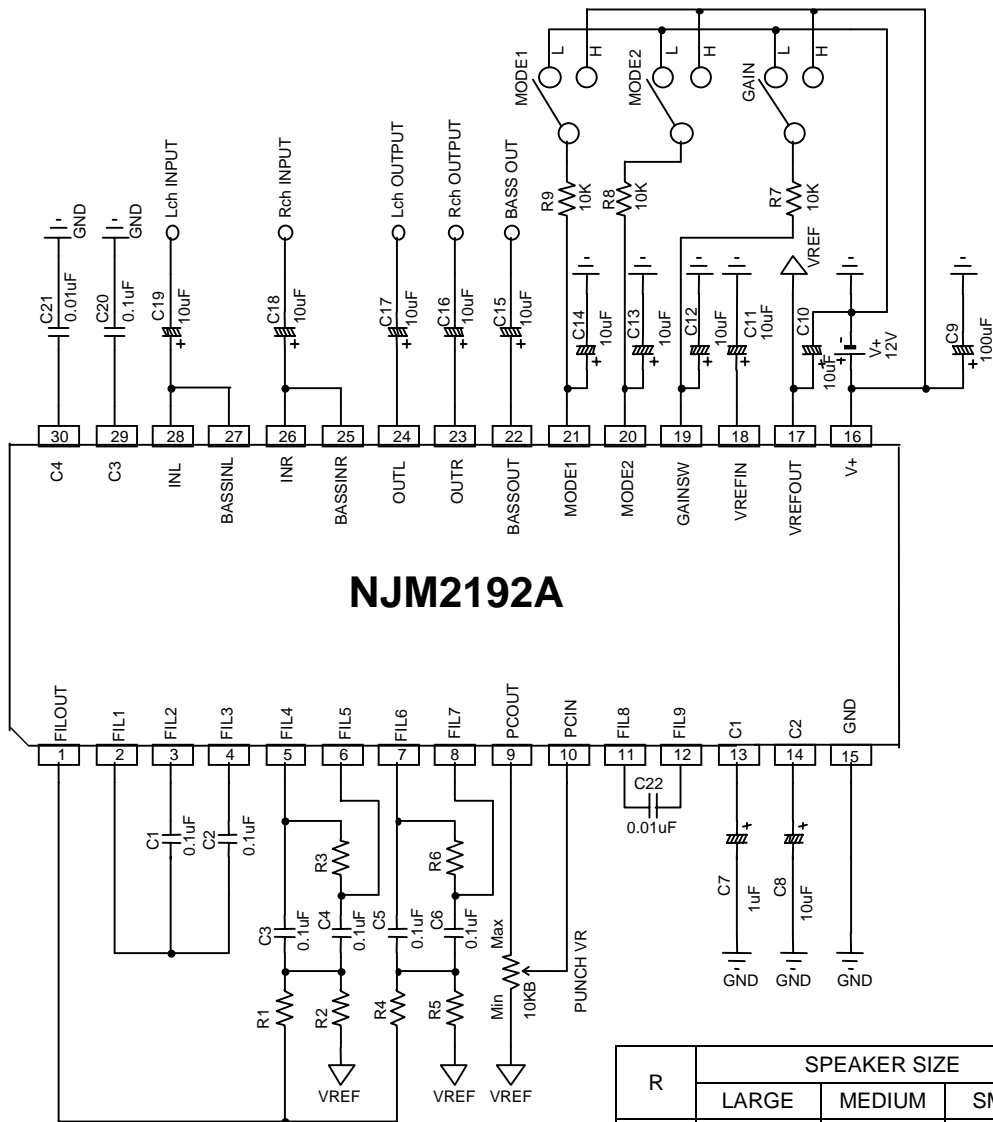

R	SPEAKER SIZE		
	LARGE	MEDIUM	SMALL
R1	56.2K	21K	21K
R2	13K	3.09K	3.09K
R3	158K	42K	42K
R4	37.4K	37.4K	22.1K
R5	8.87K	8.87K	2.32K
R6	107K	107K	32K

■ BASS1 MODE TYPICAL CHARACTERISTICS

NJM2192A(TruBass) GAIN STRUCTURE
 "Speaker Size : Small"

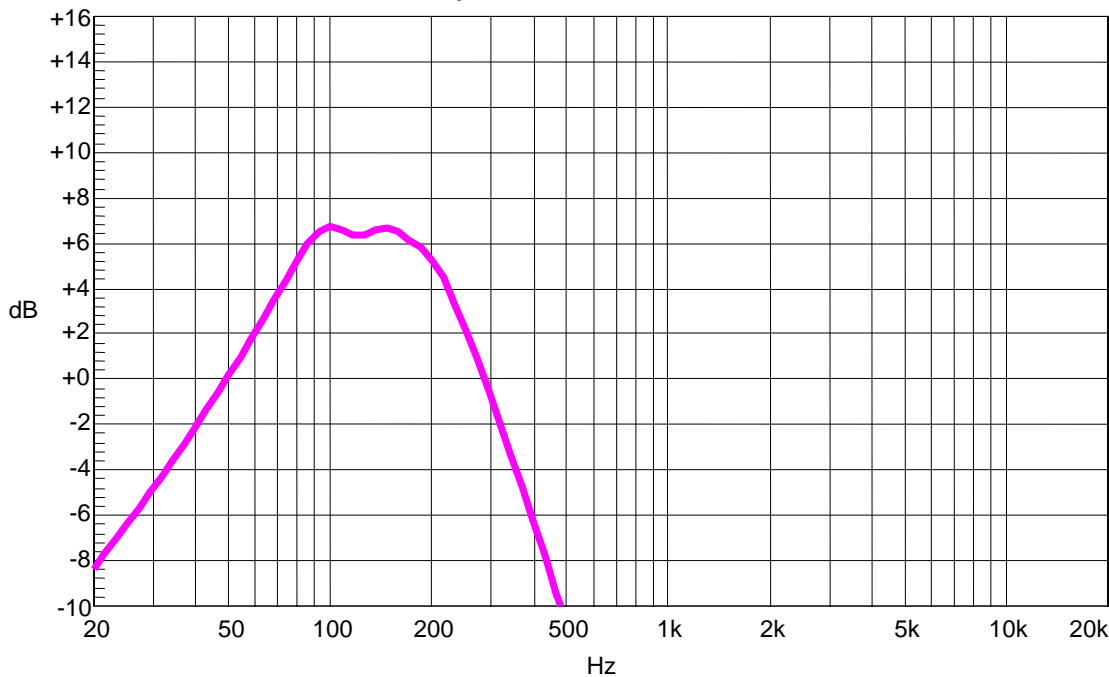

Vin=-12.2dBV(245mVrms), Lch In → Lch Out, Punch VR : MAX
 V+ = 12V

NJM2192A(TruBass) GAIN STRUCTURE
 "Speaker Size : Medium"

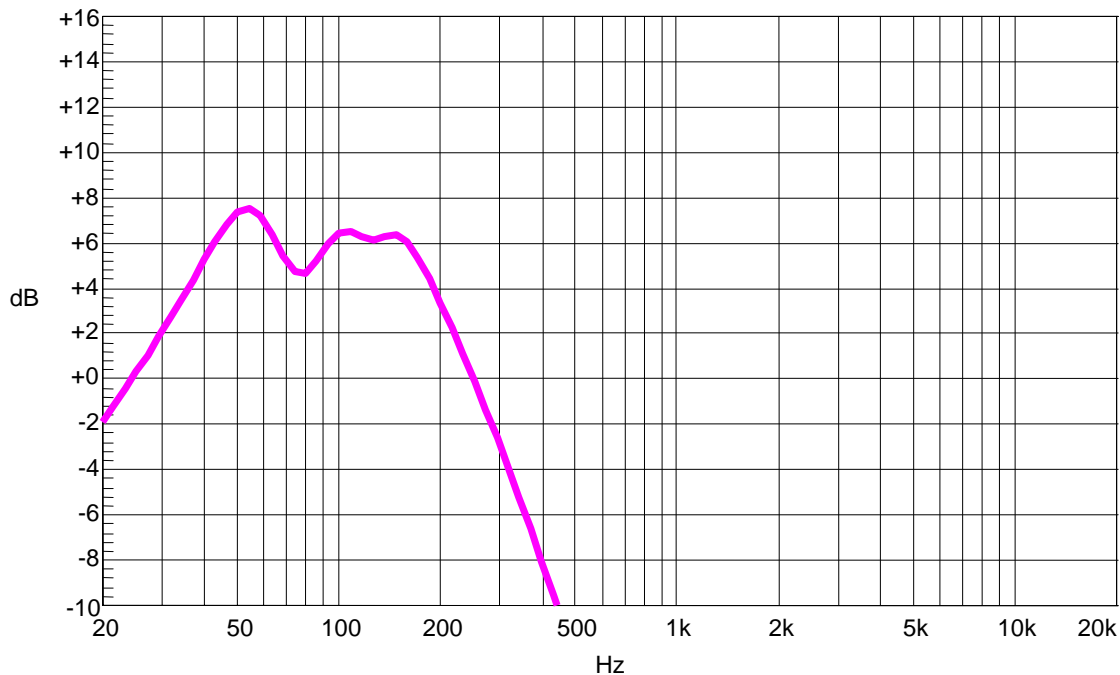

Vin=-12.2dBV(245mVrms), Lch In → Lch Out, Punch VR : MAX
 V+ = 12V

NJM2192A

www.DataSheet4U.com

NJM2192A(TruBass) GAIN STRUCTURE
"Speaker Size : Large"

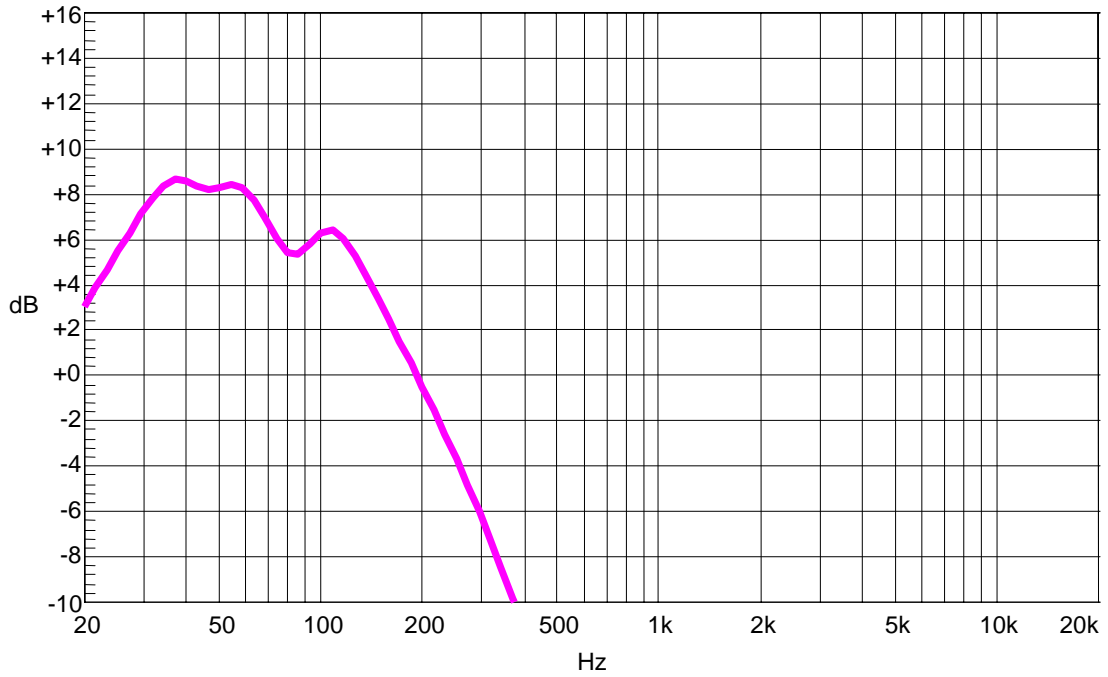

Vin=-12.2dBV(245mVrms), Lch In → Lch Out, Punch VR : MAX
V+ = 12V

■BASS2 MODE TYPICAL CHARACTERISTICS

NJM2192A(TruBass) GAIN STRUCTURE "Speaker Size : Small"

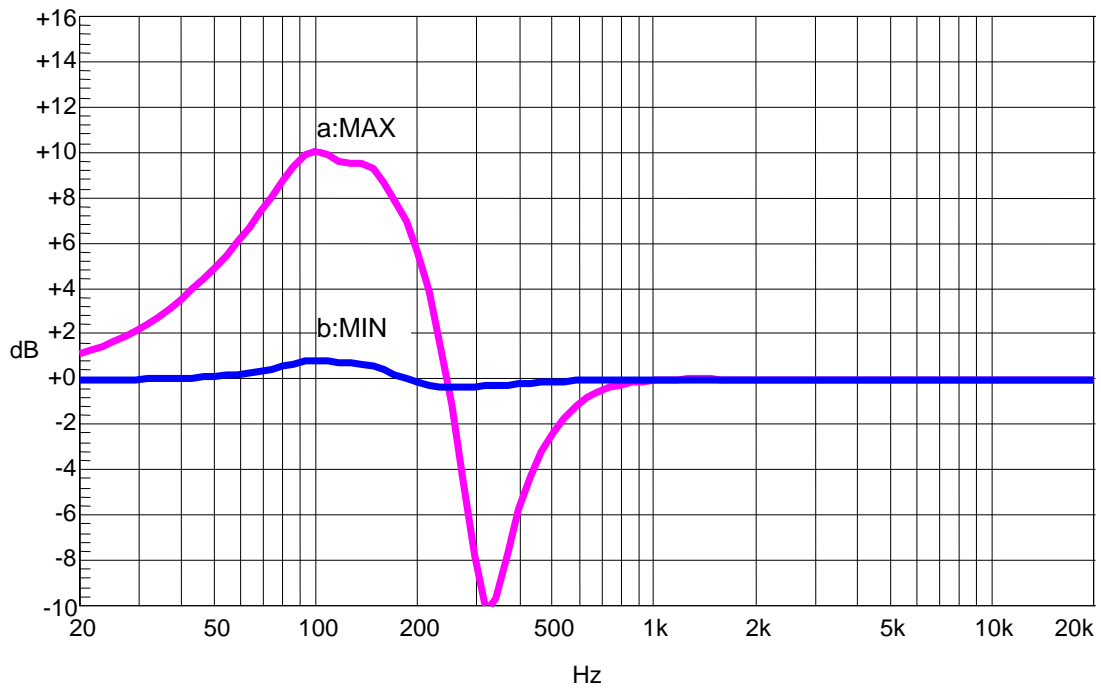

Vin=-12.2dBV(245mVrms), Lch In → Lch Out, Punch VR a:MAX, b:MIN
V+ = 12V

NJM2192A(TruBass) GAIN STRUCTURE "Speaker Size : Medium"

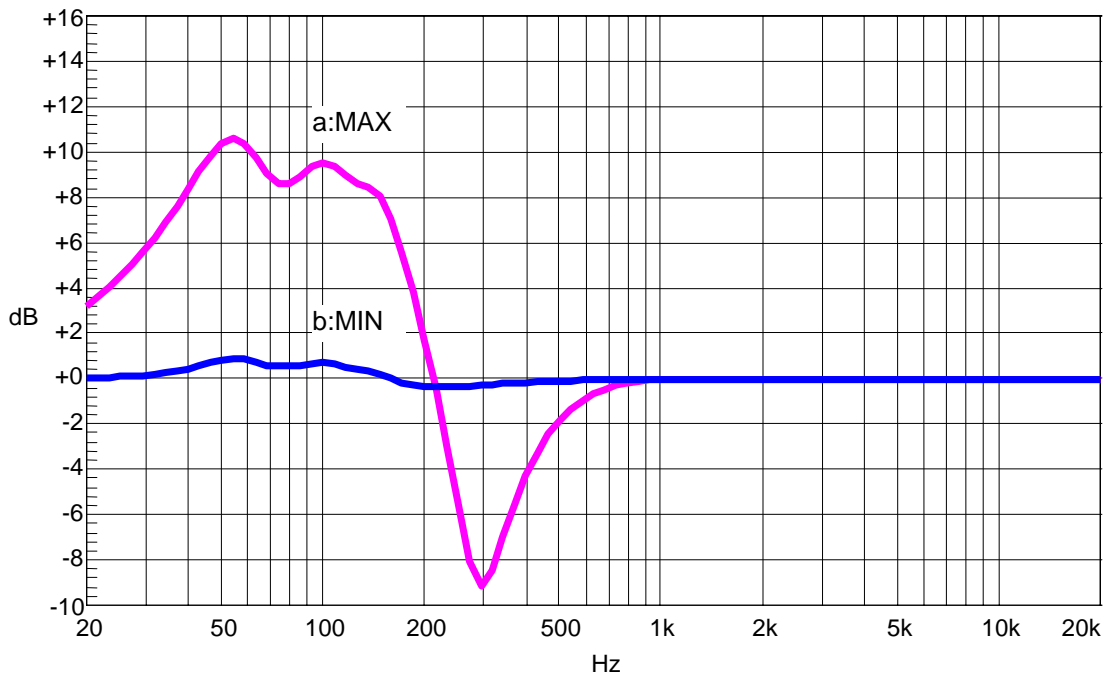

Vin=-12.2dBV(245mVrms), Lch In → Lch Out, Punch VR a:MAX, b:MIN
V+ = 12V

NJM2192(TruBass) GAIN STRUCTURE "Speaker Size : Large"

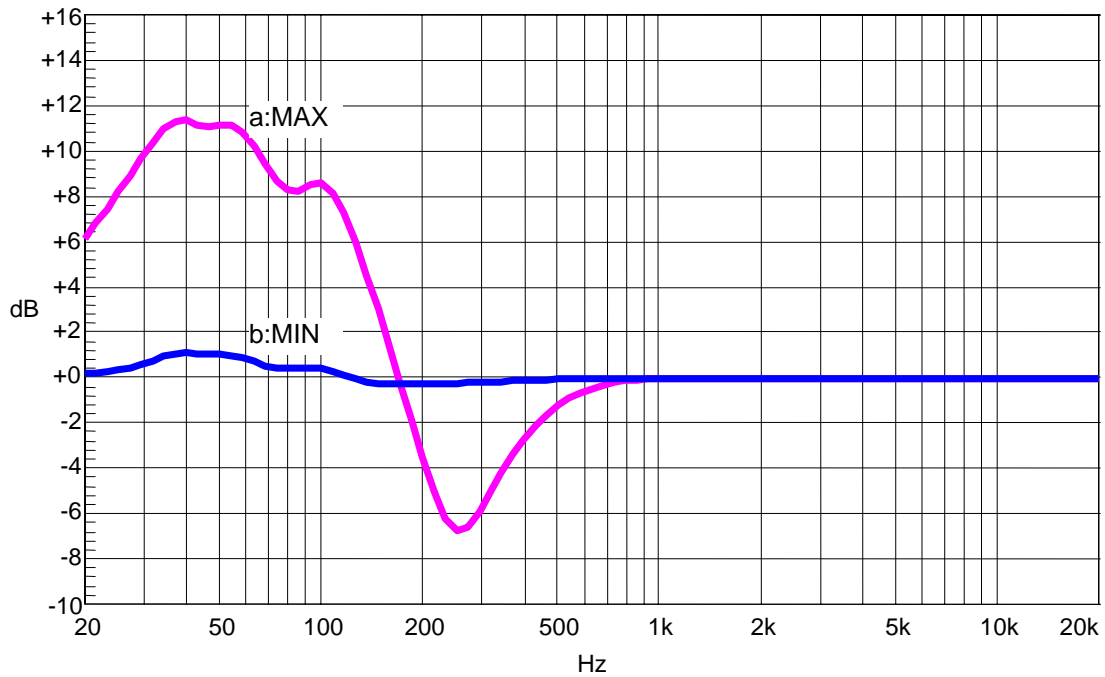

Vin=-12.2dBV(245mVrms) Lch In → Lch Out, Punch VR a:MAX, b:MIN
V+ = 12V

[CAUTION]
The specifications on this databook are only given for information, without any guarantee as regards either mistakes or omissions. The application circuits in this databook are described only to show representative usages of the product and not intended for the guarantee or permission of any right including the industrial rights.