

3-INPUT VIDEO SUPER IMPOSER WITH 75Ω DRIVER

■ GENERAL DESCRIPTION

NJM2264 is 3-input, 1-output video switch with 75Ω driver circuit. One input is provided with sink chip clamp function, which adjusts the DC level of video signal. The other two inputs of transistor open base can make control of luminance signal. This video switch can be connected to TV monitor directly, as it has 75Ω driver circuit internally.

NJM2264 is a high performance video switch which is operated with 5V supply voltage.

■ FEATURES

- Wide Operating Voltage (4.75~13V)
- 3 Input, 1 - Output
- Internal 75Ω Driver Circuit
- Internal Sink Chip Clamp Function (VIN1)
- Internal Luminance Signal Control Function (VIN2, VIN3)
- Crosstalk 70dB(at 4.43MHz)
- Wide Operating Frequency Range 10MHz(2Vp-p input)
- Package Outline DIP8, DMP8, SIP8
- Bipolar Technology

■ APPLICATIONS

- VCR, Video Camera, AV-TV, Video Disc Player.

■ BLOCK DIAGRAM

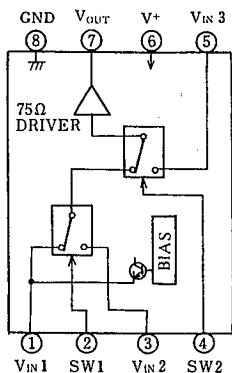

■ PACKAGE OUTLINE

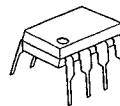

NJM2264D



NJM2264M

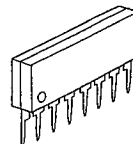

NJM2264L

5

■ ABSOLUTE MAXIMUM RATINGS

(Ta=25°C)

PARAMETER	SYMBOL	RATINGS	UNIT
Supply Voltage	V*	15	V
Power Dissipation	Pd	(DIP8) 500	mW
		(DMP8) 300	mW
		(SIP8) 800	mW
Operating Temperature Range	Topr	-20 ~ +75	°C
Storage Temperature Range	Tstg	-40 ~ +125	°C

■ ELECTRICAL CHARACTERISTICS

(V*=5V, Ta=25°C ± 2°C)

PARAMETERS	SYMBOLS	TEST CONDITIONS	MIN.	TYP.	MAX.	UNIT.
Recommended Supply Voltage	V+		4.75	—	13.0	V
Operating Current	ICC	S1=S2=S3=S4=S5=2	—	16.5	23.0	mA
Voltage Gain	Gv	VIN=2.0Vp-p, 100kHz, VO/V1	-0.8	-0.3	+0.2	dB
Frequency Characteristics	Gf	VIN=2.0Vp-p, VO(10MHz)/VO(100kHz)	-1.0	0	+1.0	dB
Differential Gain	DG	VIN=2.0Vp-p Staircase, RL=150Ω	—	0.3	—	%
Differential Phase	DP	VIN=2.0Vp-p Staircase, RL=150Ω	—	0.3	—	deg
Crosstalk	CT	V1=2.0Vp-p, 4.43MHz	—	-70	—	dB
		VO/V1	—	—	—	—
Switch Change Voltage	VCH	Switch High Level Voltage	2.4	—	—	V
	VCL	Switch Low Level Voltage	—	—	0.8	V

Note 1) Unless otherwise specified, tested with the following conditions.

a) S1=1, S2=S3=S4=S5=2 b) S2=S4=1, S1=S3=S5=2 c) S3=S5=1, S1=S2=1, S4=1 and 2

Note 2) Tested with the following conditions.

a) S1=S4=1, S2=S3=2, S5=1 and 2 b) S2=1, S1=S3=S4=2, S5=1 and 2 c) S3=1, S1=S2=S5=2, S4=1 and 2

Note 3) The Clamp Input Voltage of Vin is approximately (2.0×V+)/5 (In case of V+=5V, about 2.0V)

■ SWITCH CONTROL SIGNAL-OUTPUT SIGNAL

SW 1	SW 2	OUTPUT SIGNAL
L	L	VIN 1
H	L	VIN 2
L/H	H	VIN 3

TEST CIRCUIT

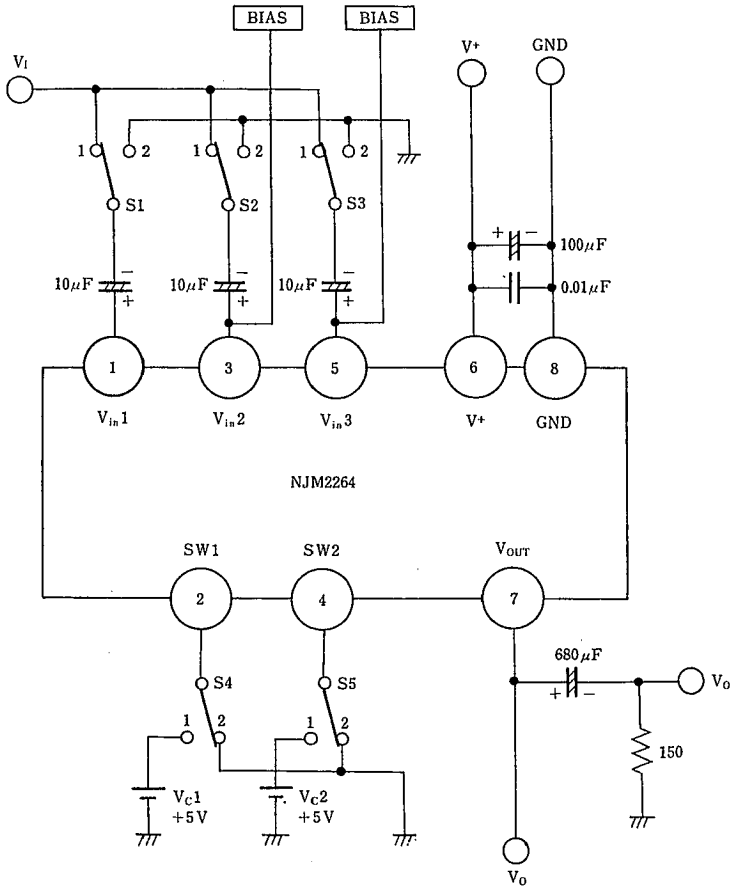

APPLICATION

Oscillation Prevention on light loading conditions

Recommended under circuit

This IC requires $1M\Omega$ resistance between INPUT and GND pin for clamp type input since the minute current causes an unstable pin voltage.

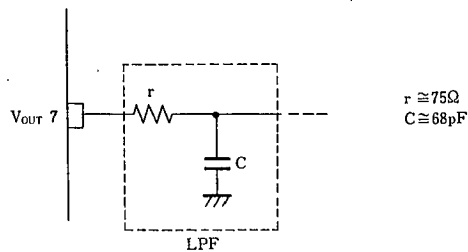

■ EQUIVALENT CIRCUIT

PIN NO.	PIN FUNCTION	INSIDE EQUIVALENT CIRCUIT	PIN NO.	PIN FUNCTION	INSIDE EQUIVALENT CIRCUIT
1	V _{IN 1}		5	V _{IN 3}	
2	SW 1		6	V ⁺	
3	V _{IN 2}		7	V _{OUT}	
4	SW 2		8	GND	

5

MEMO

[CAUTION]

The specifications on this databook are only given for information, without any guarantee as regards either mistakes or omissions. The application circuits in this databook are described only to show representative usages of the product and not intended for the guarantee or permission of any right including the industrial rights.